

**Chevron Environmental Management
Company**

Final Interim Action Work Plan

Former Unocal Edmonds Bulk Fuel Terminal
Edmonds, Washington

July 19, 2016



Peter Campbell
Senior Engineer

Scott Zorn
Technical Expert

Final Interim Action Work Plan

Former Unocal Edmonds Bulk
Fuel Terminal
Edmonds, Washington

Prepared for:
Chevron Environmental Management
Company

Prepared by:
ARCADIS U.S., Inc.
1100 Olive Way
Suite 800
Seattle
Washington 98101
Tel 206.325.5254
Fax 206.325.8218

Our Ref.:
B0045362.0005

Date:
July 19, 2016

This document is intended only for the use of the individual or entity for which it was prepared and may contain information that is privileged, confidential and exempt from disclosure under applicable law. Any dissemination, distribution or copying of this document is strictly prohibited.

Acronyms and Abbreviations	10
1. Introduction	14
1.1 Background	14
1.2 Objectives	14
1.3 Previous Submittals and Historical Data	15
1.4 Interim Action Work Plan Organization	16
2. Background	18
2.1 Site Description	18
2.1.1 Upper Yard	18
2.1.2 Lower Yard	19
2.1.3 Willow Creek Fish Hatchery	21
2.1.4 Site History	22
2.1.5 Lower Yard Creation	23
2.1.6 Historical Facilities and Operations	23
2.1.7 Former Upper Yard Facilities	24
2.1.8 Lower Yard Facilities	24
2.1.8.1 Former Loading Dock and Pier	24
2.1.8.2 Former Railcar Unloading Areas	24
2.1.8.3 Former Air-Blown Asphalt Plant	25
2.1.8.4 Former Asphalt Warehouse	25
2.1.8.5 Detention Basins No.1 and No.2	25
2.1.8.6 Former Truck Loading Racks	26
2.1.8.7 Former Oil/Water Separators	26
2.1.8.8 Former Underground Storage Tanks	27
2.1.9 Historical Releases	27
2.1.10 Lower Yard Regulatory and Ownership History	28
2.1.10.1 Agreed Order No. DE 92TC-N328	28

2.1.10.2	Agreed Order No. DE 4460	28
2.1.11	Land Use and Zoning	29
2.2	Regional Environmental Setting	29
2.2.1	Climate	29
2.2.2	Regional Geology	30
2.2.3	Regional Hydrogeology	31
2.3	Site Environmental Setting	31
2.3.1	Site Geology	31
2.3.2	Site Hydrology	32
2.3.2.1	Water Supply Wells	32
2.3.2.2	Groundwater Elevations	32
2.3.2.3	Groundwater Gradient and Direction	33
2.3.2.4	Hydraulic Conductivity	35
2.3.2.5	Surface Water – Groundwater Interaction	37
2.3.3	Surface Water	39
2.3.4	Upland Sediment	39
2.3.5	Wetlands	40
2.4	Historical Site Investigations	41
2.4.1	Onsite investigations	41
2.4.2	Offsite investigations	41
2.5	Previous Cleanup Actions	42
2.5.1	Light Nonaqueous Phase Liquid Recovery Interim Actions	42
2.5.2	Upper Yard Interim Action	42
2.5.3	Lower Yard Interim Actions	43
2.5.3.1	2001 Excavation	43
2.5.3.2	2003 Excavation	44
2.5.3.3	2007/2008 Excavation	45
2.6	Recent Investigations	48

2.6.1	2008 Lower Yard Site Investigation	48
2.6.2	2011 Lower Yard Site Investigation	49
2.6.3	2012 Lower Yard Investigation	50
2.6.4	2013 Soil Vapor Investigation	50
2.6.4.1	Soil Vapor Probe Installation	51
2.6.4.2	Soil Vapor Sampling	51
2.6.4.3	Soil Vapor Analytical Results	52
3.	Nature and Extent of Contamination	54
3.1	Soil Quality	55
3.1.1	Petroleum Hydrocarbons	55
3.1.2	Benzene	58
3.1.3	Carcinogenic Polyaromatic Hydrocarbons	58
3.1.4	Arsenic	59
3.2	Soil Vapor Quality	60
3.3	Light Nonaqueous Phase Liquid	60
3.4	Groundwater Quality	62
3.4.1	Petroleum Hydrocarbons	63
3.4.2	Carcinogenic Polycyclic Aromatic Hydrocarbons	65
3.5	Surface Water	66
3.6	Sediment	67
4.	Conceptual Site Model	69
4.1	Source Characterization	69
4.2	Remaining Impacts	69
4.2.1	Soil	69
4.2.1.1	Washington State Department of Transportation Stormwater Line	69
4.2.1.2	Detention Basin No.2 Area	71
4.2.1.3	Monitoring Well MW-129R, Southwest Lower Yard, and Southeast Lower Yard	71

4.2.1.4	Point Edwards Storm Drain	72
4.2.2	Groundwater	72
4.2.2.1	Groundwater Concentration Trends	72
4.2.2.2	Light Nonaqueous Phase Liquid.	74
4.3	Fate and Transport of Contaminants	75
4.4	Potential Receptors	76
4.4.1	Human Receptors	76
4.4.2	Ecological Receptors	76
4.5	Potential Exposures	76
4.5.1	Exposures to Human Receptors	76
4.5.1.1	Current Exposures	76
4.5.1.2	Potential Future Exposures	78
4.5.2	Exposures to Ecological Receptors	79
5.	Cleanup Standards	81
5.1	Indicator Hazardous Substances	81
5.1.1	Sediment	82
5.1.2	Surface Water and Groundwater	83
5.1.3	Soil	84
5.1.4	Surface-Water Screening for Metals	85
5.2	Sediment Cleanup Standards	85
5.3	Surface-Water Cleanup Standards	85
5.3.1	Endpoints for Cleanup Levels	85
5.3.2	Cleanup Levels	86
5.3.3	Surface-Water Points of Compliance	88
5.4	Groundwater Cleanup Standards	88
5.4.1	Endpoints for Cleanup Levels	88
5.4.2	Cleanup Levels	89
5.4.3	Groundwater Point of Compliance	89

5.5	Soil Cleanup Standards	90
5.5.1	Terrestrial Ecological Evaluation for Soil	91
5.5.2	Direct Human Contact Soil Pathway	92
5.5.3	Soil Points of Compliance	93
5.5.4	Soil Leaching Pathway	93
5.5.5	Soil Residual Saturation	94
5.5.6	Soil Vapor Pathway	95
5.5.7	Soil Dermal Contact Pathway	96
5.6	Summary of Soil and Groundwater Cleanup Levels	96
6.	Proposed Interim Action	98
7.	Additional Soil Vapor Assessment	100
7.1	Soil Vapor Probe Installation	100
7.2	Data Evaluation	102
7.3	Soil Vapor Data Screening Levels	102
8.	Remedial Implementation	103
8.1	Excavation of the Detention Basin 2 Vicinity	103
8.1.1	Description of Work	103
8.1.2	Proposed Excavation Boundary	103
8.1.3	Confirmation Sampling – Soil	104
8.1.4	Light Nonaqueous Phase Liquid and Groundwater Remediation through Excavation	105
8.1.5	Site Preparation	105
8.2	Dual-Phase Extraction for Washington State Department of Transportation Stormwater Line	107
8.2.1	System Design	107
8.2.2	System Install and Operation	108
8.2.3	System Optimization and Operation	110
8.2.4	Applicable or Relevant and Appropriate Requirements	110
9.	Pilot Testing	112

9.1	Test Locations and Equipment	112
9.2	Description of Work	113
9.2.1	Air Sparge Pilot Test	113
9.2.2	Pumping Tests	114
9.2.3	Vapor Extraction Tests	115
10.	Other Potentially Applicable Requirements	116
11.	Performance and Compliance Monitoring	117
11.1	DB-2 Excavation Activities Performance Monitoring	117
11.1.1	Stockpile Characterization Sampling	118
11.1.2	National Pollutant Discharge Elimination System Construction Permit	118
11.1.3	DB-2 Vicinity Excavation Performance Sampling	119
11.2	Long term Groundwater Compliance Monitoring	119
11.2.1	Monitoring Well Installation and borings	119
11.2.2	Groundwater Sample Collection and Analysis	120
11.3	Dual-Phase Extraction Compliance Monitoring	121
11.3.1	Dual-Phase Extraction System Monitoring	121
11.3.1.1	Puget Sound Clean Air Agency Compliance Monitoring	122
11.3.1.2	National Pollutant Discharge Elimination System Compliance Monitoring	122
11.3.2	Groundwater Compliance Monitoring	123
11.3.3	Washington State Department of Transportation Stormwater Line Soil Sampling	123
12.	Construction Documentation	124
13.	Reporting	125
14.	Public Participation	127
15.	Schedule of Deliverables	128

Tables¹

Table 2-1	Site Investigations and Remedial Actions Chronology
Table 2-2	Southeast Lower Yard Well Screen Interval Summary
Table 2-3	Revised Summary of Hydraulic Conductivity Results
Table 2-4	Remaining Impacts – Soil Sample Locations
Table 2-5	Soil Vapor Data Screening Levels
Table 2-6	2013 Soil Vapor Analytical Results
Table 5-1	Surface Water Cleanup Levels
Table 5-2	Groundwater Compliance Monitoring Wells
Table 5-3	Soil Cleanup and Remediation Levels
Table 7-1	Soil Vapor Probes Identification
Table 7-2	Soil Vapor Data Screening Levels
Table 15-1	Schedule of deliverables

Figures²

Figure 1-1	Site Location Map
Figure 2-1	Site Layout
Figure 2-2	Areas of the Lower Yard Map
Figure 2-3	Historical Facilities Location Map
Figure 2-4	Cross Section Location Map
Figure 2-5	Lower Yard Geologic Cross Section A-A'
Figure 2-6	Lower Yard Geologic Cross Section B-B'
Figure 2-7	Southeast Lower Yard Geologic Cross Section C-C'
Figure 2-8	Southeast Lower Yard Geologic Cross Section D-D'
Figure 2-9	Top of 2008 Gravel Backfill Elevations

¹ Table numbers refer to the corresponding section

² Figure numbers refer to the corresponding section

- Figure 2-10 Bottom of 2008 Gravel Backfill Elevations
- Figure 2-11 Second Quarter 2014 Groundwater Elevations and Contours – June 16, 2014
- Figure 2-12 2007/2008 Interim Action Final Excavation Limits and Volumes
- Figure 2-13 2008 Site Investigation Sample Locations and Analytical Results
- Figure 2-14 2011 Site Investigation Soil Sample Locations and Analytical Results
- Figure 2-15 2012 Soil Sample Locations and Analytical Results
- Figure 2-16 Sediment Sampling Locations and 2012 Analytical Results
- Figure 2-17 2013 Soil Vapor Sample Locations and Analytical Results
- Figure 3-1 Pre-Remediation Dissolved Total Petroleum Hydrocarbon Concentration and LNAPL Map (2006)
- Figure 3-2 Dissolved Total Petroleum Hydrocarbon Concentration and LNAPL Map (2014)
- Figure 3-3 Second Quarter 2014 TPH concentrations
- Figure 4-1 Lower Yard Remaining Soil Impacts Map
- Figure 4-2 Lower Yard Remaining Groundwater Impacts Map
- Figure 4-3 Site Soil and Groundwater Remediation Status – Second Quarter 2014
- Figure 4-4 Conceptual Site Model Exposure Pathways
- Figure 7-1 Additional Soil Vapor Assessment Locations
- Figure 7-2 Shallow Soil Vapor Probe Schematic Diagram
- Figure 7-3 Deep Soil Vapor Probe Schematic Diagram
- Figure 8-1 Excavation of the Detention Basin 2 Vicinity Plan
- Figure 8-2 Temporary Water Treatment System Flow Diagram
- Figure 8-3 Modflow Groundwater Extraction Model
- Figure 8-4 Proposed DPE System Layout
- Figure 8-5 AS, DPE, and Piezometer Well Details
- Figure 8-6 DPE Process and Instrumentation Diagram
- Figure 9-1 DPE Pilot Test Layout
- Figure 9-2 DPE System Cross Section Location Map
- Figure 9-3 DPE System Cross Section A-A'

Figure 9-4 DPE System Cross Section B-B'

Appendices

- Appendix A Selected Data from Previous Investigations
- Appendix B Soil Vapor Sampling Procedures
- Appendix C Chemical Analytical Data for 2013 Soil Vapor Sampling
- Appendix D Applicable or Relevant and Appropriate Requirements
- Appendix E 2007 TEE
- Appendix F Sampling and Analysis Plan
- Appendix G Air Sparge System Design Calculations
- Appendix H SEPA Environmental Checklist

Acronyms and Abbreviations

Agreement	Agreement of Sale of Real Property and Escrow Instructions
amsl	above mean sea level
AO	Agreed Order
APH	air-phase petroleum hydrocarbons
ARAR	applicable or relevant and appropriate requirement
ARCADIS	ARCADIS U.S., Inc.
AS	air sparge
AST	aboveground storage tank
ASTM	American Society for Testing and Materials International
bgs	below ground surface
BNSF	BNSF Railway
BTEX	benzene, toluene, ethylbenzene, and total xylenes
CAP	Cleanup Action Plan
Chevron	Chevron Environmental Management Company
CMP	Compliance Monitoring Plan
COC	constituent of concern
cPAH	carcinogenic polycyclic aromatic hydrocarbon
Csat	residual saturation concentrations
CSL	cleanup screening level
CSM	conceptual site model
CUL	cleanup level
DPE	dual-phase extraction
Draft FS	Draft Feasibility Study
Draft FS Addendum	Draft Feasibility Study Addendum
DRO	diesel range organics
Ecology	Washington State Department of Ecology

EIS	Environmental Impact Statement
EPH	extractable petroleum hydrocarbon
Final CSM	Final Conceptual Site Model
fish hatchery	Willow Creek Fish Hatchery
FS Addendum	2014 Proposed Addendum to the Draft Feasibility Study Report
ft/ft	foot per foot
GAC	granular activated carbon
gpm	gallons per minute
GRO	gasoline range organics
HI	hazard index
HO	heavy oil range organics
IHS	indicator hazardous substance
inHg	inches of mercury
LAET	lowest apparent effects threshold
LNAPL	light nonaqueous phase liquid
LRL	laboratory reporting limit
MFA	Maul, Foster, and Alongi
mg/kg	milligrams per kilogram
MNA	monitored natural attenuation
MP1	master plan 1
MP2	master plan 2
MTCA	Model Toxics Control Act
NAVD 88	North American Vertical Datum of 1988
NPDES	National Pollutant Discharge Elimination System
NRWQC	National Recommended Water Quality Criteria
NTR	National Toxics Rule

OMM	Operation and Maintenance Manual
OWS	oil/water separator
PAH	polycyclic aromatic hydrocarbon
PCB	polychlorinated biphenyl
PID	photo ionization detector
POC	Point of Compliance
Point Edwards	Point Edwards condominium complex
ppm	parts per million
‰	parts per thousand
PSCAA	Puget Sound Clean Air Agency
psi	pounds per square inch
PVC	polyvinyl chloride
REL	remediation level
RI	remedial investigation
RIWP	Remedial Investigation Work Plan
ROI	Radius of Influence
SAP	Sampling and Analysis Plan
SEPA	State Environmental Policy Act
scfm	standard cubic feet per minute
Site	Former Unocal Edmonds Bulk Fuel Terminal, located at 11720 Unoco Road, Edmonds, Washington
SMS	Sediment Management Standard
SQS	Sediment Quality Standard
SRI	supplemental remedial investigation
TEE	terrestrial ecological evaluation
TEQ	total cPAHs adjusted for toxicity
TPH	total petroleum hydrocarbons

TSS	total suspended solids
Unocal	Union Oil Company of California
USEPA	United States Environmental Protection Agency
UST	underground storage tank
VI Guidance	Draft Guidance for Evaluating Soil Vapor Intrusion in Washington State: Investigation and Remedial Action
VOC	volatile organic compound
VPH	volatile petroleum hydrocarbon
WAC	Washington Administrative Code
WDFW	Washington Department of Fish and Wildlife
WQS	Washington State Water Quality Standard
WSDOT	Washington State Department of Transportation
°F	degrees Fahrenheit
>	greater than
µg/L	micrograms per liter
µg/m ³	micrograms per cubic meter
%	percent

1. Introduction

On behalf of Chevron Environmental Management Company (Chevron), ARCADIS U.S., Inc. (ARCADIS) has prepared this Interim Action Work Plan (IAWP) for the Former Union Oil Company of California (Unocal) Edmonds Bulk Fuel Terminal, located at 11720 Unoco Road, Edmonds, Washington (Site; Figure 1-1). This IAWP is submitted to comply with Agreed Order (AO) No.DE 4460, under which Unocal, a wholly owned indirect subsidiary of Chevron Corporation, has agreed to conduct a feasibility study (FS) and interim actions at the Site, monitor groundwater in the Lower Yard; and prepare a draft Cleanup Action Plan (CAP).

1.1 Background

Chevron submitted an addendum to the Draft Feasibility Study report on August 11, 2014 proposing Remedial Alternative 6 (combination of excavation and dual phase extraction (DPE) treatment) as a preferred remedy for the remaining contamination at the Site. Ecology has asked Chevron to implement this alternative as a continuation of the interim actions required by Agreed Order No. DE 4460. This will allow DPE system performance to be observed, before Ecology makes final decision on the remedy that will be required pursuant to the Cleanup Action Plan (Ecology, 2014b). This IAWP is being submitted per Ecology's directions in that letter.

1.2 Objectives

Ecology has stated that it is appropriate to implement Remedial Alternative 6, as proposed in the Draft Feasibility Study Addendum (Draft FS Addendum; ARCADIS 2013c) as a continuation of the current interim action. The specific objectives of this interim action are presented below:

- Remediate soil in the Lower Yard that contains petroleum hydrocarbon concentrations above the soil remediation levels (RELs) and cleanup levels (CULs) in two areas: Detention Basin 2 (DB-2) and the Washington State Department of Transportation (WSDOT) stormwater line.
- Remove recoverable free product beneath DB-2 vicinity in the Lower Yard. Free product is defined as Light nonaqueous phase liquids (LNAPL).
- Obtain the data necessary to evaluate if the remaining soil concentrations will cause an exceedance of groundwater cleanup levels at the groundwater points of compliance (POCs).

- Obtain the data necessary to calculate the restoration timeframes for petroleum hydrocarbon, benzene, and carcinogenic polycyclic aromatic hydrocarbon (cPAH) concentrations to meet groundwater cleanup levels.
- Obtain data to assess whether a soil vapor pathway exists after soil and groundwater remediation.

1.3 Previous Submittals and Historical Data

Remedial actions conducted between 2001 and 2008 addressed potential impacts in the Upper Yard, Lower Yard, and sediment of Willow Creek. Specific data and documents often referred to in this IAWP include:

- Draft FS Addendum (ARCADIS 2013c) evaluates Remedial Alternative 6 Excavation with Monitored Natural Attenuation to address contamination in the vicinity of DB- 2 and Soil and Groundwater Treatment using Dual-Phase Extraction (DPE) to address contamination near the WSDOT stormwater line.
- Final Conceptual Site Model (Final CSM; ARCADIS 2013a) evaluates remaining impacts, potential fate and transport of the remaining impacts, and potential receptors and exposure pathways.
- The Cleanup Levels and Remediation Levels Report (ARCADIS 2013c) evaluates and confirms the CULs and RELs for soil, groundwater, and surface water.
- The final compliance soil samples collected in 2007/2008 during remedial excavation activities and documented in the Phase I Remedial Implementation As-Built Report (ARCADIS 2009).
- Final Phase II Remedial Implementation As-Built Report (ARCADIS 2010a).
- The 2008 site investigation work that was conducted near the WSDOT stormwater line and the former asphalt warehouse (ARCADIS 2010b).
- The 2011 site investigation work, which incorporated a tidal study, pumping tests, and investigation of soil conditions near DB-2 (ARCADIS 2012a).
- Investigation activities conducted as part of the Revised Feasibility Study Work Plan (ARCADIS 2012b) in August 2012, which included additional groundwater monitoring well installation, additional groundwater sampling, and sediment sampling.

Historical data, tables, figures, and laboratory reports are provided in the documents listed above and are referenced in this IAWP.

Remedial actions conducted between 2001 and 2008 addressed potential impacts in the Upper Yard, Lower Yard, and sediment of Willow Creek. ARCADIS evaluated the location, concentrations, and distributions of remaining hydrocarbon impacts in the Lower Yard at the Site using the 2012 investigation results and historical data. Few areas with remaining impacts to soil and groundwater exist in the Lower Yard.

1.4 Interim Action Work Plan Organization

The remaining sections of this IAWP are summarized below:

- *Section 2 – Background.* Describes the three areas of the Site and historical facilities, operations, and releases at the Site. Summarizes historical property ownership and regulatory actions, including the AO.
- *Section 3 – Nature and Extent of Contamination.* Describes constituents of concern (COCs) and remaining soil and groundwater impacts.
- *Section 4 – Conceptual Site Model.* Evaluates fate and transport, potential receptors, and potential exposure pathways.
- *Section 5 – Cleanup Standards.* Describes cleanup standards and development of CULs for sediment, soil, groundwater, and surface water.
- *Section 6 – Proposed Interim Action.* Describes the components of the proposed interim action.
- *Section 7 – Additional Soil Vapor Assessment.* Describes the need for and details of the soil vapor sampling to be conducted at the Site to supplement previous soil vapor investigations and to proceed with Remedial Alternative 6.
- *Section 8 – Remedial Implementation.* Presents remedial implementation components.
- *Section 9 – DPE Pilot Test.* Provides details for the pilot test.
- *Section 10 – Other Potentially Applicable Requirements.* Describes regulatory requirements to be considered for the construction activities at the Site.

- *Section 11 – Performance and Compliance Monitoring.* Describes performance and compliance sampling to be conducted at the Site.
- *Section 12 – Construction Documentation.* Lists the logs to be completed during construction.
- *Section 13 – Reporting.* Describes documents to be submitted during and after excavation construction.
- *Section 14 – Public Participation.* Presents a public participation plan.
- *Section 15 – Schedule of Deliverables.* Presents anticipated deliverables and expected submittal dates.
- *Section 16 – References.* Lists the references cited throughout this IAWP.

2. Background

2.1 Site Description

As defined in the AO, the Site consists of three areas: Upper Yard, Lower Yard, and Willow Creek Fish Hatchery (fish hatchery). The Upper and Lower Yards were areas of operation for the former terminal. Background information for the Upper Yard, Lower Yard, and fish hatchery is provided in paragraphs 2.1.1 to 2.1.3. Table 2-1 presents a chronologic summary of investigation activities at the Site.

2.1.1 Upper Yard

The approximately 25-acre Upper Yard is located to the south of the Lower Yard. East of the Upper Yard is the fish hatchery and State Route 104. Beyond State Route 104 are residential and commercial areas in the town of Edmonds, Washington. South of the Upper Yard is a large residential area in the town of Woodway, Washington. To the west of the Upper Yard are BNSF Railway (BNSF) tracks, and, west of the tracks, the Port of Edmonds Marina and a public park, then Puget Sound. The Upper Yard is shown on Figure 2-1.

The surface elevation of the Upper Yard ranges from approximately 20 to 100 feet above mean sea level (amsl). The majority of the Upper Yard is approximately 90 to 100 feet amsl. The northern boundary of the Upper Yard is a steep decline in elevation into the Lower Yard (approximately 75 to 80 feet higher than the majority of the Lower Yard).

Remediation of the Upper Yard began in 2001. In 2003, upon the completion of remedial actions described in Section 2.6.2, Ecology issued a letter (Ecology 2003) indicating that the Upper Yard Interim Action had met direct contact for soil cleanup criteria as specified in the SLR Interim Action Report (SLR 2007a). However, as defined in the AO, the Upper Yard is part of the Site.

Unocal sold the Upper Yard to Point Edwards, LLC in October 2003. The former Upper Yard area is zoned master plan 1 (MP1), which allows for residential and commercial uses. Currently, the former Upper Yard is occupied by the Point Edwards condominium complex (Point Edwards). The Point Edwards condominium complex is fully developed, including underground and overhead utilities and a stormwater system:

- The development includes several high-occupancy residential buildings, administrative buildings, parking areas, landscaping areas, and outdoor walking path. The slope from the Upper Yard to the Lower Yard is covered by immature

growth of vegetation planted by Point Edwards, LLC, during the construction of Point Edwards.

- The former Upper Yard is served by a stormwater system operated by Point Edwards, LLC that conveys stormwater to a sedimentation/detention pond located in the northern part of the former Upper Yard. This system connects the Point Edwards stormwater retention pond and the tidal basin leading to Puget Sound via a 36-inch-diameter underground drainpipe that runs beneath the Lower Yard and discharges into the tidal basin. The Point Edwards storm drain line is made of corrugated acrylonitrile butadiene styrene (ABS) plastic, is located approximately 3 to 5 feet bgs, and runs parallel to the WSDOT stormwater line across the Lower Yard.

2.1.2 Lower Yard

The approximately 22-acre Lower Yard surrounds the Upper Yard to the north, east and west. It is currently owned by Unocal. Unocal and WSDOT have entered into a purchase and sale agreement that provides WSDOT will assume ownership of the property after Capital Remediation Work has been completed. WSDOT currently plans to move the Edmonds Ferry Dock to the Site as part of the Edmonds Crossing Project. The Lower Yard is shown on Figure 2-1 and the areas of the Lower Yard discussed in this IAWP are presented on Figure 2-2.

The western boundary of the Lower Yard is the BNSF Railway property line, and the northwestern boundary is Willow Creek and the BNSF Railway property line. Further west of the Lower Yard is the Port of Edmonds Marina and Puget Sound. North and northeast of the Lower Yard are the Edmonds Marsh and Willow Creek. East of the Lower Yard is the Edmonds Marsh and Willow Creek, and southeast is the fish hatchery. At its nearest point (the southwest corner of the Lower Yard), the Lower Yard boundary is approximately 160 feet from the Puget Sound shoreline.

The surface elevation of the majority of the Lower Yard ranges from approximately 10 to 19 feet amsl based on North American Vertical Datum of 1988 (NAVD 88) and is relatively flat. However the southeastern-most portion of the Site, on Unoco Road near the Lower Yard entrance, is approximately 35 feet amsl. Upper Unoco Road continues along the southern property boundary, drops in elevation, and turns into Lower Unoco Road at the south-central portion of the Site. From upper Unoco Road near the Lower Yard entrance, the ground surface drops in elevation to the north from approximately 35 to 16 feet amsl in the south-central portion of the Site. On the south side of upper Unoco Road, there is a large paved area along the property boundary.

Willow Creek runs along the northern portion of the western boundary and the entire eastern boundary of the Lower Yard. Willow Creek is approximately 10 feet wide and is underlain by silt and sand material. The creek banks on the property boundary are steeply sloped and vegetated with native and non-native vegetation. Willow Creek is tidally influenced. At high tide water flows from Puget Sound upstream into Edmonds Marsh and at low tide water drains from Edmonds Marsh into Puget Sound. Further information is provided in Section 2.4.2.5. Water depths in Willow Creek vary from 0 to 4 feet deep, depending on season and tidal cycles (ARCADIS 2012a).

The Lower Yard is currently a vacant property, with no permanent aboveground structures. A temporary storage shed is located along Unoco Road in the central portion of the Lower Yard. The ground surface is compact dirt, gravel, and natural vegetative cover. The Lower Yard is zoned master plan 2 (MP2), which allows for use as a multi-modal transportation facility as well as mixed general residential and commercial uses. Residential use is prohibited on the ground floor of any building on this property.

Twelve storm drains collect surface water runoff. The collected water is conveyed via gravity flow to detention basin DB-2. Stormwater also collects in detention basin DB-1 from direct precipitation and overland flow. DB-1 and DB-2 form depressions approximately 6 and 4 feet deep, respectively, and can be described as followed:

- DB-1 is located in the east/northeast Lower Yard and west/northwest Lower Yard. DB-1 is bounded to the northwest, northeast, and southeast by a manmade berm. The berm runs along the eastern property boundary, adjacent to Willow Creek. DB-1 acts as a retention pond for overflow from DB-2 during storm events. DB-1 is an unlined pond with one aboveground pump and a piping system to the DB-2 outfall on the bank of Willow Creek. When necessary, water in DB-1 is pumped into DB-2 and discharged from DB-2.
- DB-2 is located between the west/northwest Lower Yard and central Lower Yard, south of DB-1. DB-2 serves as a stormwater collection area from which Lower Yard stormwater is discharged into Willow Creek under Industrial Stormwater General Permit No. SO3-002953C. DB-2 has an impermeable liner, two submersible pumps, and a piping system to the DB-2 outfall.

A WSDOT stormwater line crosses beneath the Lower Yard and discharges collected stormwater to Puget Sound. According to a 1971 drainage plan (Washington State Highway Commission, 1971), the WSDOT stormwater line is composed of sections of increasing diameter from 48 inches at the eastern part of the site to 72 inches at the western part of the site, as shown on Figure 2-1 The WSDOT stormwater line is made

of asphalt-coated corrugated metal and crosses the Lower Yard at depths of 9 to 12 feet below ground surface (bgs) to the top of the pipe. The WSDOT stormwater line generally runs along the northern edge of lower Unoco Road and trends west across the Lower Yard to the tidal basin leading to Puget Sound. The WSDOT stormwater line was installed between 1972 and 1975 and is a major stormwater drainage structure for State Route 104; WSDOT evaluated the stormwater line in 2011 and found its integrity to be sound, with no visible signs of deterioration. In addition, a separate stormwater line connects the Point Edwards stormwater retention pond and the tidal basin leading to Puget Sound. The Point Edwards storm drain line runs parallel to the WSDOT stormwater line across the Lower Yard. The Point Edwards storm drain line is made of corrugated ABS plastic and crosses the Lower Yard at depths of approximately 3 to 5 feet bgs.

The only paved areas of the Site are Unoco Road and the large paved area to the south of upper Unoco Road. The majority of the Site is covered with 3-inch quarry spall stones and silty sand and gravel backfill material. Vegetation such as grasses, alder saplings, and native blackberries have begun to reclaim the Site around its perimeter and throughout most of the southeast Lower Yard. Occasionally, gorse (*Ulex Europeus*) growth is encountered in the Lower Yard. Gorse is a weed that displaces native plants. Gorse removal activities were conducted in the Lower Yard in December 2014. The berm surrounding DB-1 is covered by native vegetation.

Upon completion of 2008 interim action activities, the banks of Willow Creek were restored. Native estuarine wetlands species were planted in the floodplain areas of the creek, comprising areas not in the creek channel but below the high water mark. In addition to the floodplain species, trees, shrubs, and grasses (meant to stabilize and protect the bank from erosion and invasive species) were planted on the Lower Yard side of the creek, above the high water line. The plantings were installed through cuts made in BioNet, a woven biodegradable straw mat material used as an erosion control measure, at a density and pattern designated by a wetland biologist.

2.1.3 Willow Creek Fish Hatchery

The southeast portion of the Site, near the entrance to the Lower Yard, was leased by Unocal to the Edmonds Chapter of Trout Unlimited in 1984. In 1985, an easement was issued by Unocal for development of the property as a fish hatchery. This property is now owned by the City of Edmonds. The property was formerly known as the Deer Creek Fish Hatchery and is currently known as the Willow Creek Fish Hatchery.

The fish hatchery currently consists of a building that is approximately 50 feet long and 20 feet wide, a circular fish rearing pond approximately 40 feet in diameter, and a small

pump house. The remainder of the developed property is composed of a compact gravel driveway and grass and landscaped areas. Surface-water runoff from the property drains directly into Willow Creek.

Although the fish hatchery was included in the AO, it was not used for operations or storage at the Site by Unocal and remained undeveloped until 1985 when the fish hatchery was constructed. Historical information was reviewed prior to development of the Remedial Investigation Work Plan (RIWP [EMCON 1995]), which indicated that field investigations of the fish hatchery property were not warranted.

2.1.4 Site History

Unocal operated the terminal from 1923 to 1991. Petroleum products were brought to the terminal on ships, pumped to storage tanks in the Upper Yard, and loaded from the storage tanks into rail cars and trucks for delivery to customers. In addition, an asphalt plant operated at the terminal from 1953 to the late 1970s.

In 2001, Unocal conducted an interim action in the Lower Yard, removing LNAPL and petroleum-impacted soil and groundwater from four areas of the Lower Yard. Results of the 2001 interim action are summarized in the Lower Yard Interim Action As-Built Report (Maul, Foster, and Alongi [MFA] 2002). Additional interim actions conducted in 2003 included soil excavations in the southwest Lower Yard and DB-1. Results of the 2003 interim action are summarized in the 2003 Lower Yard Interim Action As-Built Report (MFA 2004a). Previous excavations are shown on Figure 2-1.

In June 2007, Unocal entered into an AO with Ecology to conduct an interim action in the Lower Yard. Specific objectives of the interim action included:

- Remove soil with petroleum impacts in excess of the soil RELs established for the terminal.
- Remove LNAPL.
- Extract groundwater that is in contact with LNAPL.
- Remove soil with arsenic concentrations in excess of the CULs from the southwest Lower Yard.

The soil RELs were calculated to identify a concentration that is protective of direct contact. RELs are believed to be protective of groundwater as well. Groundwater monitoring was conducted to provide empirical evidence that RELs are protective of

groundwater. Soil CULs and RELs are identified in the Interim Action Report – Work Plan for 2007 Lower Yard Interim Action (IAWP – Lower Yard; SLR 2007a), and are summarized in Section 5.5.2.

2.1.5 Lower Yard Creation

Prior to 1923, when the main facility structures of the terminal were constructed, the area of the Lower Yard was tidal marshland. To provide usable working and building surfaces, backfill material was placed over the marsh, presumably beginning in the early 1920s. As seen in aerial photos of the Site (EMCON 1994), in 1947 only the southwest Lower Yard area was developed and contained structures and facilities. The central, eastern, northeastern, and southeastern portions of the Lower Yard were undeveloped marshland at this time. By 1955, backfilled areas, structures, and facilities had expanded to the central area of the Lower Yard. The northeastern and southeastern portions of the Lower Yard were still undeveloped marshland. By 1965, the Lower Yard was filled and developed in all areas except in the southeast, and remained so throughout facility operations.

2.1.6 Historical Facilities and Operations

Historical operations at the Site conducted by Unocal included the storage and distribution of petroleum products, and the production, storage, and distribution of asphalt products. Facilities at the Site included a loading/unloading dock in Puget Sound, railcar unloading areas, an aboveground tank farm, piping systems, an air-blown asphalt plant, asphalt warehouse, laboratory, truck loading racks, oil/water separators (OWSs), underground storage tanks (USTs), and stormwater and sewer systems (EMCON 1994). The southeastern Lower Yard was used as a waste soil stockpile area for material removed from two local Unocal service stations (EMCON 1994).

A series of aboveground and underground pipelines, valves, and manifolds were used at the Site to move product between areas of receipt, storage, blending, packaging, and distribution in both the Upper and Lower Yards. The product pipes and valves were made of steel and ranged in diameter from 1.5 to 12 inches. Product was received at the terminal and distributed via barge, ship, tanker, railcar, truck, drums, and cartons.

This IAWP discusses Site operations and facilities; detailed operations and historical activities are presented in the Background History Report (EMCON 1994). Historical facility operations areas and structures discussed in this section are presented on Figure 2-3.

2.1.7 Former Upper Yard Facilities

Construction of the Upper Yard began in 1923, along with the main terminal structures and loading dock. The Upper Yard consisted of 23 aboveground storage tanks (ASTs), two USTs, above-grade piping, a garage, and a warehouse. Above-grade piping carried petroleum materials up the hill from the loading dock in the Lower Yard to the ASTs in the Upper Yard. The ASTs ranged in capacity from 9,726 to 3,491,754 gallons. The ASTs in the Upper Yard were primarily used to store and blend products.

The Upper Yard ASTs were contained within soil berms coated with emulsified asphalt. Except for the bermed areas and paved roads, the Upper Yard had a gravel surface. Precipitation infiltrated the gravel, and stormwater was collected in catch basins that drained to an OWS in the Lower Yard (EMCON 1994).

2.1.8 Lower Yard Facilities

2.1.8.1 Former Loading Dock and Pier

Unocal owned and operated a 275-foot dock and 860-foot pier extending westward into Puget Sound from the southwest corner of the Lower Yard. The dock loading area received daily deliveries of gasoline, fuel oils, and crude oils from tanker ships in Puget Sound (EMCON 1994), and transferred the deliveries to the Upper Yard ASTs via a piping system. The piping from the dock and pier passed over the BNSF Railway line via a trestle at the end of the pier. The dock, pier, and trestle were constructed in 1923. The dock facilities included a system of pipes and valves, including ten 2- to 12-inch-diameter steel pipes. Pipelines from the dock ran aboveground to the shoreline manifold area, in the southwest corner of the Lower Yard. The piping then ran southeast up the hillside to the southwest portion of the Upper Yard, as well as northeast along the toe of the hillside to the north-central portion of the Upper Yard, to the Upper Yard ASTs.

2.1.8.2 Former Railcar Unloading Areas

Two railcar loading/unloading areas were located in the southwest Lower Yard. The southern railcar loading/unloading area was constructed in the early 1930s. The time of construction of the northern railcar unloading area is unknown. Railcar service to the Lower Yard was discontinued in the 1960s and the unloading areas were dismantled in 1974 (EMCON 1994).

The southern loading/unloading area was approximately 40 feet wide by 310 feet long, and was located along the property boundary in the southwest Lower Yard. This

loading/unloading area consisted of two railroad spurs parallel to the BNSF Railway line, with loading/unloading racks parallel to the railroad spurs. The northern loading/unloading area was located immediately south of the tidal basin leading to Puget Sound, and was approximately 10 feet wide by 70 feet long (EMCON 1994). Railcar tankers were loaded and unloaded in these areas on a regular basis for approximately 30 years.

2.1.8.3 Former Air-Blown Asphalt Plant

The air-blown asphalt plant was constructed in approximately 1953 and covered a large portion of the west/northwest Lower Yard, adjacent to DB-1 and the former slops pond area (further described in Section 2.2.4.5). Various grades of air-blown asphalt were produced in this facility, including crack-pouring compound, sub-sealing compound, and canal-lining asphalt. The air-blown asphalt plant was designed to produce up to 100 tons per day and the asphalt products were packaged into 100-pound cartons or steel drums. Materials used in the manufacturing of air-blown asphalt included tank bottom material from the facilities' existing crude distillation column and flux oil shipped to the Site by tanker or rail.

2.1.8.4 Former Asphalt Warehouse

The asphalt warehouse was a steel-framed building that was constructed in 1953, along with the asphalt plant. The 80- by 280-foot warehouse was located in the central Lower Yard, parallel to the southern edge of DB-1. Operations in the asphalt warehouse consisted of packaging asphalt from the air-blown asphalt plant. Asphalt was pumped from cooling tanks into a 6-inch-diameter pipe that ran in a trench down the centerline of the building. The asphalt was then pumped into containers using a loading arm. These containers were loaded into and distributed via truck and trailer.

2.1.8.5 Detention Basins No. 1 and No. 2

DB-1 is located in the East/Northeast Lower Yard and is approximately 200 by 600 feet in size. DB-1 was constructed in 1952; the original layout was an L-shape with a leg extending south along the northwestern property boundary. DB-1 was constructed by dredging sediment from the northeastern and northwestern Site perimeters, creating a drainage channel (Willow Creek) to carry the flow from small creeks draining surface water from upland areas in the City of Edmonds.

In the late 1960s, DB-1 was modified by partitioning off the southern leg and creating an impoundment area to contain refinery and asphalt sludges and runoff (EMCON 1994). The impoundment area became known as the "slops pond." In 1974, the slops

pond was backfilled and DB-2 was constructed. DB-2 is fully lined with polyvinyl chloride (PVC) liner material and contains outfall pumps that discharge to Willow Creek (EMCON 1994).

2.1.8.6 Former Truck Loading Racks

Two truck loading racks were located in the Lower Yard. A two-lane gasoline and diesel loading rack was located in the central Lower Yard and a single-lane loading rack was located in the southwest Lower Yard along the toe of the slope leading to the Upper Yard. It is unclear when the loading racks were constructed, but in approximately 1977 they were modified from top-loading racks to bottom-loading racks. This reportedly minimized the potential for accidental releases and product loss during truck loading. Spill containment controls at each rack consisted of a concrete pad, concrete curbs, and strip drains that led to a 10,000-gallon UST separator tank (EMCON 1994).

2.1.8.7 Former Oil/Water Separators

Two OWSs were located in the Lower Yard, approximately 150 feet south of DB-2. The OWSs were used to remove oil from the Site's wastewater prior to its discharge into Willow Creek.

The main OWS was built in approximately 1950 and was a concrete vault measuring approximately 45 feet long, 18 feet wide, and 11 feet deep. The main OWS had an open top at ground surface, with baffles and skimmers to remove oil product as wastewater passed through the vault. Product removed from the main OWS was pumped into one of the ASTs in the Lower Yard. Stormwater drains in the Upper and Lower yards carried stormwater flow to the main OWS since its construction in 1950 until removal of the OWS in 2007. Prior to 1950, wastewater treatment and disposal practices at the Site were not documented.

The secondary OWS was located immediately northwest of the main OWS. The secondary separator was made of steel, consisted of a series of four cells, and contained a full-length float skimmer. This unit was installed in approximately 1974 when DB-2 was constructed and was used for additional treatment of wastewater to meet National Pollutant Discharge Elimination System (NPDES) discharge standards (EMCON 1994).

2.1.8.8 Former Underground Storage Tanks

Eleven USTs operated at the Site until 1985. UST capacity varied from 200 to 10,000 gallons and the USTs were installed at various times from the pre-1950s to 1985.

Ten of the USTs were located throughout the Lower Yard and one was located in the Upper Yard. The USTs were made of welded steel, except for the delivery truck slops tank installed in 1985, which was made of fiberglass.

The UST located in the Upper Yard was removed in 1984; its installation date and intended use are unknown. Three USTs in the Lower Yard were located near the facilities garage and were used to fuel Site trucks and equipment. One UST in the Lower Yard contained diesel fuel and was used to fuel the on-site boiler. One of the Lower Yard USTs contained fuel additive that was mixed during truck loading at the two truck loading racks. One Lower Yard UST was a delivery truck petroleum slops tank, where delivery lines from ingoing and outgoing trucks were drained. Two of the Lower Yard USTs collected truck loading rack overflow, spills, and rainwater from the strip drains at each of the truck loading racks. Two of the Lower Yard USTs served as vapor recovery tanks that collected condensed vapor from the vapor recovery system.

2.1.9 Historical Releases

Facility operations began in the early 1920s with the construction of the Unocal pier and main facilities of the Upper and Lower Yards. Although no spills were documented during this time, data collected during the 2007/2008 interim action excavations indicated that soil impacts were present at depths deeper than Site groundwater fluctuations. Specifically, impacts were found in layers of beach and marsh deposits below the 1929 fill unit, suggesting that releases potentially occurred in either the undeveloped marshland areas of the Lower Yard prior to backfill placement, from the early 1920s to the 1950s, or were transported vertically through the saturated zone by a fluctuating groundwater table through time.

From 1954 to 1990, several documented spills occurred at the terminal, totaling approximately 155,000 gallons. Spilled quantities ranged from a few gallons to 80,000 gallons and involved fuel oils, heavy oils, gasoline, off-specification asphalt, and diesel products. Periodic product releases (approximately 0.2 gallon to 2 gallons) reportedly occurred from valves, flanges, and pumps in the Upper and Lower Yards throughout the terminal history. Records and documentation of these smaller releases are not available. A number of remedial actions have been performed to address releases listed above and are summarized in Section 2.6.

2.1.10 Lower Yard Regulatory and Ownership History

2.1.10.1 *Agreed Order No. DE 92TC-N328*

In 1993, Unocal entered into AO No. DE92TC-N328 with Ecology. Under the AO, remedial investigations were conducted during the 1990s. Interim actions were conducted under the AO in the Upper and Lower Yards during 2001 and 2003, as discussed in Sections 2.6.2 and 2.6.3. This AO was superseded in 2007 by the current AO (No. DE 4460), as discussed in Section 2.2.6.2.

2.1.10.2 *Agreed Order No. DE 4460*

In June 2007, Unocal entered into AO No. DE 4460 with Ecology to conduct an interim remedial action at the Lower Yard. This AO superseded AO No. DE92TC-N328. AO No. DE 4460 required Unocal to conduct an interim action to remediate soil, groundwater, and sediment; and to monitor groundwater in the Lower Yard. The purpose of the interim action was to reduce potential threats to human health and the environment, and to gather information to design additional cleanup actions, if necessary. Specific objectives of the interim action included:

- Remediate the petroleum hydrocarbon-impacted soil in the Lower Yard with petroleum hydrocarbon concentrations greater than the soil RELs or soil CULs based on direct contact.
- Remove LNAPL from four areas of the Lower Yard.
- Extract groundwater that is in contact with LNAPL.
- Remove soil with arsenic concentrations in excess of the soil CUL based on natural background concentrations.
- Remove sediment from Willow Creek at locations near the Site's two stormwater outfalls that failed toxicity tests in 2003.
- Obtain the data necessary to evaluate if the remaining soil concentrations are sources of LNAPL on the groundwater table.
- Obtain the data necessary to evaluate if the remaining soil concentrations will cause an exceedance of the groundwater CULs at the groundwater POCs.

- Obtain the data necessary to evaluate if petroleum hydrocarbon concentrations in groundwater beneath the Lower Yard will naturally attenuate to below the CULs at the groundwater POCs.

The 2007 interim actions were conducted in two phases in 2007 and 2008, as described in Section 2.6.3.3.

2.1.11 Land Use and Zoning

The Lower Yard is zoned MP2, which allows for use as a multi-modal transportation facility as well as mixed general residential and commercial uses. The Upper Yard is zoned MP1, which allows for residential and commercial uses. Properties surrounding the Lower Yard consist of various commercial, industrial, recreational, and residential sites. The property immediately north-northeast of the Site (Edmonds Marsh) is designated open space. Farther north, Harbor Square (a commercial development) is zoned commercial general. Land use in the town of Woodway, located immediately south of the Site, is primarily single-family residential. The properties east of the Lower Yard, to the east of State Route 104, are zoned under public use, multifamily, and single-family residential designations. The BNSF Railway right of way, Port of Edmonds Marina, Marina Beach Park, and Puget Sound shoreline to the west-northwest of the Site are zoned commercial waterfront.

2.2 Regional Environmental Setting

2.2.1 Climate

The Site is located on the eastern shore of Puget Sound, less than 100 miles inland from the Pacific Ocean. Puget Sound lies in a basin between the Olympic Mountains on the west, which form a significant barrier to onshore wind flow from the Pacific, and the Cascade Mountains to the east, which shields the area against westerly flow of colder and drier continental air masses. As a result, the climate of the Puget Sound is temperate, with mild to moderate precipitation and temperatures year-round in the Edmonds, Washington area. Occasionally, winter storms will bring heavy rainfall, strong winds, or snowfall. Average temperatures are typically in the 30s and 40s degrees Fahrenheit (°F) during winter, and range from the 50s to 70s °F during spring, summer, and fall. The annual precipitation is approximately 36 inches and consists mostly of rain that falls between October and March.

2.2.2 Regional Geology

The Edmonds, Washington area is located in the Puget Sound Lowland, bound by the North Cascade Mountains and South Cascade Mountains to the east and the Olympic Mountains and Willapa Hills to the west. Continental glaciers advanced into the region several times during the Pleistocene Epoch (between 2 million and 10,000 years ago). This part of the Cordilleran ice sheet is known as the Puget Lobe. The most recent period of glaciation, the Vashon Stade, began approximately 15,000 years ago. As the climate cooled during the Vashon Stade, the continental ice sheet in Canada expanded and the Puget Lobe slowly advanced southward into western Snohomish County and beyond. The ice of this Vashon Glacier blanketed the entire Puget Sound Basin before halting and retreating (Thomas 1997).

As the Vashon Glacier advanced southward, streams and melting ice in front of the glacier deposited sediment throughout the Puget Sound Lowland. As the glacier continued its advance, it overrode these advance outwash deposits and covered them with glacial till. This till, also known as hardpan, consists of reworked older deposits and rocks scoured by the bottom and sides of the advancing glacier. Because of the pressure of thousands of feet of overlying ice, the till is compact and cemented in some areas, with a texture much like concrete. However, local deposits of fine- and coarse-grained sediment resulted in areas where the till was subjected to the influence of sub-glacial water during deposition. Approximately 13,500 years ago, the climate began to warm and the Vashon Glacier started to retreat. During this retreat, recessional outwash sediment was deposited, filling in discontinuous depressions and channels in front of the glacier. Subsequent to the deposition of glacial sediment, alluvial sediment of Holocene age (10,000 years ago to the present) was deposited. These are predominantly fluvial deposits of sand and gravel in stream and river valleys. During the same time, bog, marsh, and peat deposits were formed in small low-lying and poorly drained areas (Thomas 1997).

As a result of the glacial and fluvial activity and erosion during the Pleistocene Epoch, the Site is underlain by unconsolidated sediment of both glacial and non-glacial origin. Beneath these deposits are consolidated Tertiary rocks. The thickness of the entire assemblage of unconsolidated deposits varies considerably, but averages approximately 500 feet thick, with a maximum thickness of more than 1,200 feet. The deposits are thickest in western Snohomish County and are thinner to the east where the Tertiary bedrock is at or near land surface (Thomas 1997).

The Upper Yard is located on top of a bluff and the Lower Yard is situated at the foot of the bluff, along its northern edge. The Upper Yard bluff consists of three main types of deposits: interglacial deposits (Whidbey Formation), alluvial/lacustrine pre-glacial

deposits (Transitional Beds and Advance Outwash), and glacial deposits (till) (Minard 1983). The Lower Yard bounding the bluff is composed of marsh deposits to the northeast and “modified land” that has been dredged and filled to the north and northwest (MFA 2004c).

2.2.3 Regional Hydrogeology

Groundwater flow in the Puget Sound region generally, and at the Site in particular, can be divided into large- and small-scale flow systems. Large-scale flow systems near the Site exist in unconsolidated, glacially derived units, and in the marine sediment and volcanic rocks underlying them. These systems are recharged by precipitation in upland areas, east of the sound, where the units are exposed. Large-scale, regional system discharge is into Puget Sound. Small-scale, local flow systems occur in the uppermost deposits of alluvial and lacustrine pre-glacial sediment, glacial sediment, and post-glacial alluvium, as well as in construction-related backfill. Precipitation and deeper flow systems are the chief methods of recharge for these local flow systems. Discharge of local systems is to adjacent surface-water bodies, which for the Site, is into the Puget Sound.

2.3 Site Environmental Setting

2.3.1 Site Geology

Five hydrostratigraphic units have been identified in the Lower Yard:

- *2008 Fill*. The 2007-2008 interim action excavations were backfilled to 6 to 12 inches above the observed groundwater table in the open excavations with poorly graded coarse gravels ($\frac{3}{8}$ to 1 inch) and little to no fines. Backfill material above the coarse gravel to ground surface was a mixture of very fine to medium sand, trace silt, and fine to medium gravel materials.
- *1929 Fill*. This unit consists of silty sands with gravel and sandy silts with gravel. During the 2007-2008 interim action excavations, subsurface materials encountered from ground surface to a depth of 8 to 15 feet bgs were mostly fill material placed circa 1929 or later, during creation of the Lower Yard facility.
- *Marsh Deposits*. In many areas of the Lower Yard, beneath the 1929 fill unit, a 1- to 15-foot-thick layer is present and is composed of silt and sandy silt with large amounts of organic matter such as peat and wood debris. This layer is encountered at depths ranging from 8 to 14 feet bgs, directly below the 1929 fill unit, and is interpreted to be representative of the former marsh horizon beneath

the Lower Yard. This layer is typically demarcated by a 6- to 12-inch-thick layer of decomposing vegetation.

- *Beach Deposits.* Below the 1929 fill unit and marsh deposits, a poorly graded sand formation of very fine to medium sand with fine gravel is present, containing organic material such as driftwood and seashells. This layer is interpreted to be representative of the former beach environment in the area prior to creation of the Lower Yard.
- *Whidbey Formation.* This material is a poorly graded sand layer consisting of very fine to medium sand with fine gravel and is distinct from the overlying materials in the Lower Yard. It is present to the maximum depth explored by Unocal (41.8 feet bgs). This unit contains interbedded sand with silt and interbedded silt and sandy silt. The interbeds range in thickness from less than 1 inch to several feet and appear to be laterally discontinuous. This unit is interpreted to be alluvium and is likely part of the Whidbey Formation.

The current uppermost stratigraphic unit of the Lower Yard consists primarily of 2008 fill. The 2007/2008 interim action excavations were extended to reach beach deposits, marsh deposits, or Whidbey Formation materials. Remaining unexcavated areas are likely 1929 fill material, underlain by the hydrostratigraphic units described above. Cross sections of the Lower Yard are presented on Figures 2-4 through 2-8. Elevations of the 2008 gravel backfill material in the 2007/2008 excavation areas are shown on Figures 2-9 and 2-10.

2.3.2 Site Hydrology

2.3.2.1 Water Supply Wells

According to a review of Ecology and Snohomish Health District files, no potable water supply wells exist within $\frac{1}{4}$ mile of the Site. One abandoned test well is located approximately $\frac{1}{3}$ mile northeast of the Site boundary and was used for dewatering during construction of the Edmonds wastewater treatment plant. The nearest domestic supply well, installed in 1995, is approximately $\frac{1}{4}$ mile south of the Site boundary. This well is upgradient from the Site, and therefore, could not be affected by the impacted groundwater beneath the Site.

2.3.2.2 Groundwater Elevations

Groundwater elevations throughout the Lower Yard have remained consistent throughout the period of record (October 2008 to June 2014), with average

groundwater elevations ranging between 5 and 9 feet amsl. This does not include groundwater elevation data collected in the southeast Lower Yard, which indicate an area of localized groundwater mounding exists. During the period of record, average groundwater elevations in the southeast Lower Yard were between 9 and 11 feet amsl. Historical groundwater elevations throughout the Site (excluding the southeast Lower Yard) varied from 2.24 feet amsl at well MW-147 in September 2011 to 11.20 feet amsl at well MW-109 in December 2011. The highest average historical groundwater elevations (8.71 and 8.89 feet amsl) are observed in monitoring wells MW-203 and MW-134X (in the upper Unoco Road portion of the southeast Lower Yard). The lowest average historical groundwater elevations (5.21 and 5.49 feet amsl) are observed in monitoring wells MW-301 and MW-149R in the southwest Lower Yard.

Historical groundwater elevations in the southeast Lower Yard ranged from 6.21 feet in well MW-136 in August 2009 to 15.21 feet amsl in piezometer P-1 in January 2010. The historical average groundwater elevation in the southeast Lower Yard is 9.82 feet amsl.

Groundwater elevation data from June 2014 were contoured and are presented on Figure 2-11. In general, the seasonal variation includes the difference between the highest groundwater elevations observed during January and the lowest groundwater elevations observed between June and September.

2.3.2.3 Groundwater Gradient and Direction

Quarterly water-level data from October 2008 to June 2012 were evaluated to assess the long-term hydraulic gradient and overall gradient direction in the Lower Yard. Groundwater elevations during this time period ranged from approximately 2 to 15 feet amsl and generally decreased from south to north-northwest, primarily toward Puget Sound and Edmonds Marsh (east). Depth to water values ranged from approximately 0.6 foot to 27 feet below top of casing. In general, the greatest depth to water values occur near the entrance to the Lower Yard (on upper Unoco Road) and near the central portion of the Site, decreasing with proximity to Puget Sound (to the north) and Edmonds Marsh (southeastern portion of the Lower Yard). Using the quarterly data to calculate a Site-wide gradient (Devlin 2003), the analysis indicates that the overall average gradient is 0.002 foot per foot (ft/ft) toward the west-northwest. This evaluation did not include the newly installed monitoring wells (June 2012), MW-500, MW-501, or the P-series piezometers.

The 2011 investigation activities at the Site included evaluation of potential tidal influence on groundwater and surface water (ARCADIS 2012a). As described in

Section 2.7.2, the results indicate that tidal variations in water levels in the Puget Sound influence groundwater elevations at the Site perimeter.

Groundwater gradient in the southeast portion of the Lower Yard is also influenced by the 2007/2008 interim action excavations and subsequent 2008 fill. After the 2008 fill was in place and monitoring wells were installed, groundwater elevations in wells MW-500 and MW-501 were observed to be approximately 5 to 7 feet higher than surrounding wells. Further investigation in the area indicated that water levels at piezometers screened partially in the 2008 fill and the underlying 1929 fill also exhibit these higher groundwater elevations.

Horizontal gradients in the surficial materials of the Lower Yard measured during tidal study activities conducted in 2011 ranged in magnitude from 0.0053 to 0.0058 ft/ft, with an overall direction to the west-northwest toward Puget Sound (ARCADIS 2012a).

2.3.2.3.1 Southeast Lower Yard Groundwater Mounding

Groundwater elevations in monitoring wells MW-500 and MW-501 are generally several feet higher (5 to 7 feet) than elevations at surrounding wells. Wells MW-500 and MW-501 are partially installed in 2008 fill, but are also partially screened in the underlying 1929 fill material.

In July 2009, in an effort to understand the higher groundwater elevations, eight piezometers were installed in the southeast Lower Yard near monitoring wells MW-500 and MW-501. The piezometers were installed in pairs, with each piezometer approximately 1 to 2 feet from each other. One piezometer of each pair was installed as a deep well (ranging from 25 to 22 feet bgs) and one piezometer was installed as a shallow well (ranging from 12 to 13 feet bgs). The deep piezometers were constructed with 5 feet of well screen and the shallow piezometers were constructed with 10 feet of well screen. The piezometers and wells MW-500 and 501 are presented in Table 2-2.

Table 2-2. Southeast Lower Yard Well Screen Interval Summary

Well ID	Classification	Well Screen Interval (Geologic Material)
P-1	Shallow	2008 fill/1929 fill
P-2	Deep	1929 fill
P-3	Shallow	2008 fill
P-4	Deep	1929 fill
P-5	Shallow	2008 fill
P-6	Shallow	2008 fill/1929 fill
P-7	Deep	1929 fill/Whidbey Formation
P-8	Deep	1929 fill/Whidbey Formation
MW-500	Shallow (Monitoring Well)	2008 fill/1929 fill
MW-501	Shallow (Monitoring Well)	2008 fill/1929 fill

All shallow piezometers, which are installed in either the 2008 fill or both the 2008 fill and the 1929 fill, have groundwater elevations consistent with those observed in monitoring wells MW-500 and MW-501. The groundwater elevations in the shallow piezometers are also several feet higher than the corresponding deeper piezometers, which are installed in the 1929 fill or both the 1929 fill and the Whidbey Formation.

The 2008 fill material is a higher permeability material than the 1929 fill that underlies and surrounds the 2007/2008 interim action excavation areas in the southeast Lower Yard. The 2008 fill appears to have created a distinct zone in which shallow groundwater responds more rapidly to recharge than the surrounding and underlying 1929 fill. Movement of groundwater from the 2007/2008 interim action excavation area (both laterally and vertically) is restricted due to the presence of the lower permeability 1929 fill. Additionally, surface-water runoff from the bluff along the Upper Yard may be contributing some recharge to this portion of the Site. As a result, water levels near the 2007/2008 interim action excavation area indicate a limited area of groundwater mounding due to the differential permeabilities. Cross sections of the southeast Lower Yard, with historical groundwater elevation data, are shown on Figures 2-7 and 2-8. Groundwater elevation contours and data from the June 16, 2014 gauging event are presented on Figure 2-11.

2.3.2.4 Hydraulic Conductivity

Results of the hydraulic conductivity testing conducted during the 2011 site investigation indicate that hydraulic conductivity varies throughout the Lower Yard and corresponds to the heterogeneity of the subsurface materials. The 1929 fill is of lower

permeability than the 2008 fill material. Wells completed in the 2008 fill have relatively higher hydraulic conductivity values than those completed in the 1929 fill (ARCADIS 2012a). Hydraulic conductivity testing results from 2011 site investigation activities range from 0.06 foot/day to 345 feet/day, with hydraulic conductivity values at wells completed in the 1929 fill ranging from 0.2 foot/day to 15 feet/day and hydraulic conductivity values at wells completed in the 2008 fill ranging from 2.5 to 345 feet/day (ARCADIS 2012a).

This IAWP presents a revised summary table of hydraulic conductivity results from the 2011 Site investigation (ARCADIS 2014b) (Table 2-3). Additionally, the 2011 Site Investigation Completion Report (ARCADIS 2012a) indicates that step test data from LM-2 were analyzed, but a valid result could not be obtained from the analysis. Therefore, the value estimated at LM-2 was only from slug testing.

Hydraulic conductivity results of the hydraulic testing activities, including step drawdown tests, short-duration hydraulic conductivity tests, long-duration hydraulic conductivity tests, and slug tests, are presented in Table 2-3, along with the screened interval lithology.

Table 2-3. Revised Summary of Hydraulic Conductivity Results

Tested Well	Minimum Estimated Hydraulic Conductivity (foot [feet]/day)	Maximum Estimated Hydraulic Conductivity (foot [feet]/day)	Arithmetic Mean Hydraulic Conductivity (foot [feet]/day)	Well Screen Interval (geologic material)
LM-2	0.3	0.4	0.3	1929 fill
MW-104	4.7	15	10	1929 fill
MW-129R	0.2	0.5	0.3	1929 fill
MW-149R	2.5	2.5	2.5	2008 fill
MW-500	0.06	0.2	0.1	2008 fill/1929 fill
MW-518	5.8	10	8	2008 fill
MW-8R	186	345	259	2008 fill

Source: Revised 2011 Site Investigation Completion Report (ARCADIS 2014b).

2.3.2.5 Surface Water – Groundwater Interaction

The 2011 site investigation included a study to evaluate the potential interaction between Puget Sound, groundwater at the Lower Yard, and surface water in Willow Creek. Results are presented in the 2011 Site Investigation Completion Report (ARCADIS 2012a) and summarized below.

Based on the tidal study, the Lower Yard perimeter wells (located within approximately 62 feet of the property boundary) are tidally influenced. Shallow monitoring wells with observable response to tidal influence indicated a range in amplitude from 0.07 foot to 1.15 feet. Deeper monitoring well MW-122, completed in the Whidbey Formation, indicated a range in amplitude from 0.02 to 0.33 foot (ARCADIS 2012a). The range of elevations during the monitored period varied between 8.60 to 8.93 feet amsl (ARCADIS 2014b). Wells monitored during the tidal study indicate higher tidal efficiency factors (or the ratio of the change in water level in a groundwater well compared to the change in water level in a tidally affected water body) along the northwest boundary wells adjacent to Puget Sound, compared to interior wells and southeast boundary wells adjacent to the marsh. Results indicate that the average tidal efficiency varied between approximately 0.003 (LM-2 and MW-515) and 0.09 (MW-149R). The average tidal efficiency of all the wells studied was 0.03. The values are relatively low, likely due to the low permeability and heterogeneity of material at the Site. The relatively low tidal efficiency values observed at monitoring wells at the Site indicate that groundwater levels at the Site are not significantly influenced by tidal changes in Puget Sound (ARCADIS 2014b).

A comparison of groundwater elevations to Puget Sound water elevations measured during the 2011 tidal study indicates that the short-term groundwater gradient direction near the tidal boundaries varies with the tidal stage. At most of the observed perimeter locations during high tide, the Puget Sound water elevation is higher than groundwater elevations in the Lower Yard, indicating an inward flow direction near the boundary. However, at that same time, groundwater gradients between perimeter and interior wells remained almost unchanged, indicating outward flow. Thus, the region experiencing gradient reversal is limited to the aquifer below and near the tidal surface waters. At low tide the opposite is true, and groundwater gradient is toward Puget Sound both within the Site and at the margins. Exceptions to this occur at MW-122, MW-500, and MW-501. At these locations, during the tidal study, elevations were higher than the Puget Sound except at the “high” high tide stage (ARCADIS 2012a).

Data collected during the 2011 tidal study from transducers installed at staff gauges in Willow Creek indicate that Willow Creek is tidally influenced. At locations where Willow Creek was monitored with transducers, the flow direction is such that at high tide, the

Puget Sound elevation is greater than surface-water elevations in Willow Creek, and at low tide Willow Creek elevations are greater than those in Puget Sound. Puget Sound flows into Edmonds Marsh at high tide and Edmonds Marsh drains into Puget Sound at low tide. This is consistent with the observations of groundwater elevation compared to Puget Sound elevations.

Salinity was also measured in Willow Creek during the tidal study. Salinity variations were observed to correlate to the tidal stage at staff gauges with observable tidal influence. As observed during 2011 tidal study activities, flow during high tide in the Puget Sound is directed toward Willow Creek and salinity concentrations in Willow Creek increase. During low tide in Puget Sound, the flow direction reverses and flow is from Willow Creek toward Puget Sound while salinity concentrations decrease in the creek. During some tidal cycles in the 2011 tidal study monitored period, surface-water elevations in Willow Creek were greater than those in Puget Sound during both low and low high tides. Staff gauge D-6R (located in DB-1) did not identify any observable tidal influence, indicating that DB-1 has little to no connection to Puget Sound. Staff gauges with observable tidal responses to tidal influence indicated a range in amplitude from 0.02 foot to 3.73 feet. Fluctuations in surface-water elevations in Willow Creek ranged from 3.06 to 8.76 feet amsl (ARCADIS 2012a).

Based on the water level data and salinity collected during the 2011 tidal study, not only does the flow direction vary with tide, but water from Puget Sound is mixing with water in Willow Creek and, to a lesser extent, with groundwater. This is indicated by the water level response to tidal fluctuations and the varying salinity concentrations observed at the staff gauge locations. This is also occurring at the tidally influenced monitoring wells; however, the magnitude of responses to tidal fluctuations and salinity concentrations is less at the wells than observed in Willow Creek.

Willow Creek is directly hydraulically connected to Puget Sound through a culvert running under the Port of Edmonds, which also likely contributes to the greater tidal response and higher salinity concentrations. Therefore, based on groundwater elevations, surface-water elevations, and salinity changes, data from the tidal study indicate that groundwater flow is directed to surface water over the long term. However, local, transient flow direction also changes as a result of tidal stage fluctuations in Puget Sound where surface water is directed to groundwater. This unique hydraulic and hydrogeological setting creates a mixing zone along the western boundary where groundwater, fresh water, and salt water interact, at times stagnating and ultimately reversing groundwater gradient at the western boundary of the Site.

2.3.3 Surface Water

At its nearest point (the southwest corner of the Lower Yard), the Site is approximately 160 feet from the Puget Sound shoreline. The Site is bounded by Willow Creek, which runs along the northern portion of the western boundary and the entire eastern boundary of the Lower Yard. To the north and northeast of the Lower Yard is Edmonds Marsh, which is a 23-acre freshwater and brackish-water marsh. This tidally influenced marsh is fed by Shellabarger Creek on the southeast side of the marsh and drains a portion of the City of Edmonds stormwater system. Willow Creek connects Edmonds Marsh to Puget Sound and carries surface water into a tidal basin, where the water is conveyed beneath the Port of Edmonds through a culvert to Puget Sound. Willow Creek and Edmonds Marsh are directly connected to Puget Sound and are tidally influenced. During periods of high tide, flow in Willow Creek will be toward Edmonds Marsh, and Edmonds marsh partially fills with water. During low tide, Edmonds Marsh will drain into Puget Sound.

2.3.4 Upland Sediment

Upland sediment on the banks of Willow Creek, the tidal basin, and the berm surrounding DB-1 are partially to fully inundated during high tides. During low tides, these areas are fully exposed. Observations during field activities conducted since 2007 indicated that sediment at the bottom of the main channel of Willow Creek is constantly submerged. The water covering the upland sediment is generally brackish (1 to 30 parts per thousand [‰] salinity) as a result of the mixing of surface water runoff with saltwater from tidal incursion. In June 1995, upland sediment pore water salinities measured between 11 and 21 ‰ at depths of up to 10 centimeters (MFA 2001b).

In 1995, upland sediment was investigated and sampled for characterization. The results of this investigation were reported in the Draft Remedial Investigation Report (MFA 2001b) and are summarized below.

Upland sediment observed along the northeast boundary of the Site was highly organic, very soft to firm, olive brown to black sandy silt (MFA 2001b). Upland sediment that was at an elevation high enough to support perennial vegetation retained a peat-like composition. Sediment located in the bottom of Willow Creek and along the northwest boundary of the Site was generally loose, olive gray to gray, silty sand. Tidal basin sediment was loose, gray to brown, gravelly sand. Reducing sediment indicative of anoxic conditions was observed along the northeast boundary of the Site. Amphipods were observed in the upland sediment (MFA 2001b).

Sediment samples in Willow Creek were collected for indicator hazardous substance (IHS) analysis in 1996, 2003, and 2012, as discussed in Section 3.6.

2.3.5 Wetlands

In 2001, CH2M HILL prepared an Environmental Impact Statement (EIS) for the U.S. Department of Transportation Federal Highway Administration and WSDOT in preparation for the future construction of the Edmonds Crossing multi-modal transportation center on the Lower Yard. The EIS (CH2M HILL 2001) included a wetland delineation of the Lower Yard, Edmonds Marsh and its surrounding areas. During development of the EIS (CH2M HILL 2001), three wetland areas were identified at or adjacent to the Site:

- Edmonds Marsh.
- A freshwater marsh on the east side of Highway 104 that was part of Edmonds Marsh before construction of the highway (now known as Edmonds City Park).
- DB-1 area of the Lower Yard.

Two riparian corridors were also identified: one associated with Shellabarger Creek at the north end of Edmonds City Park and the Willow Creek riparian corridor that runs through the Deer Creek Fish Hatchery.

Edmonds Marsh is classified by the City of Edmonds as a Category I (high-quality) wetland based on its uniqueness, large size, and habitat for a state monitor species (great blue heron) (CH2MHILL 2001). It is also designated as a priority habitat in the Washington Department of Fish & Wildlife (WDFW) Priority Habitat and Species Database. The primary functions of the approximately 23-acre Edmonds Marsh are flood storage and desynchronization, sediment trapping, nutrient removal, water quality improvement, wildlife habitat, fish habitat, and passive recreation. Edmonds Marsh is tidally influenced, receiving saltwater during high tides from Willow Creek and freshwater from Shellabarger Creek.

The 3.7-acre freshwater marsh on the east side of Highway 104 is rated as a Category II wetland. Its primary functions are flood storage and desynchronization, sediment trapping, nutrient removal, water quality improvement, and limited biological support. This wetland receives freshwater from Shellabarger Creek and from upland areas to the south and southeast.

The 2.3-acre DB-1 wetland area is located within the Lower Yard. The DB-1 area would likely be classified as a Category III wetland due to its small size, lack of vegetative diversity, disturbed condition, and lack of hydraulic connectivity to Edmonds Marsh. The only source of freshwater to DB-1 is precipitation, surface runoff during heavy precipitation events, and overflow from DB-2.

2.4 Historical Site Investigations

2.4.1 Onsite investigations

Historical investigations at the Site indicated that in general, the areas of petroleum hydrocarbon-impacted soil at the Site coincided with historical operations. Impacts in the Upper Yard were found near AST basins, stormwater drain lines, product piping lines, and facility operations areas. In the Lower Yard, impacts were generally found near the asphalt plant, railcar loading racks, truck loading racks, and fuel storage and distribution areas. Areas of the Lower Yard containing soil impacted with metals (specifically arsenic) were identified in locations where tanks and pipes were sandblasted with arsenic-containing sandblast grit. Impacts were found in the southeast Lower Yard, although historical facility activities were not conducted in this area. During 2007/2008 interim action excavation activities, it was observed that the southeast Lower Yard was used as a disposal area for impacted soil, construction debris, and other waste material. These historical site investigations are summarized in Table 2-1 and in the various reports referenced in this IAWP. Pertinent data tables from historical site investigations are included in Appendix A.

Historical information reviewed for development of the RIWP (EMCON 1995) indicated that field investigations of the fish hatchery property were not warranted because the fish hatchery area was not impacted by discharges from facility operations.

2.4.2 Offsite investigations

Historical investigations were conducted offsite on Admiral Way (soil borings SB-1 to SB-7 in 2001), along the BNSF railroad (monitoring wells MW-27 to MW-29 in 1991 and MW-105 to MW-107 and MW-137 in 1995) and on the port of Edmonds property (soil borings P-1 to P-9 in 1997 and LAI-DP-6 to LAI-DP-16 in 2004) (MFA 2003b, EMCON. 1998, Landau Associates, Inc. 199 and, Landau Associates, Inc. 2004).

Offsite investigations identified local areas of soil impacted with TPH or cPAHs, which are believed to be the result of offsite releases and are not expected to cause impacts to the Site. These conclusions are based on the review of chromatograms from soil impacts detected onsite that did not resemble the petroleum hydrocarbons found in the

soil sample collected from the Port of Edmonds property soil explorations. Furthermore, soil and groundwater collected along the BNSF railroad, located between the Site and the observed impacts did not exceed Site REL or CULs.

Data tables and figures from historical offsite investigations are included in Appendix A.

2.5 Previous Cleanup Actions

Cleanup actions and site investigations have been ongoing at the Site since 1986. In 1993, Unocal entered into AO No. DE-92TC-N328, which was superseded by 2007 AO No. DE 4460, as discussed in Section 2.2.6. In accordance with the AO, Unocal conducted interim action cleanup activities at the Upper and Lower Yards, as described below.

2.5.1 Light Nonaqueous Phase Liquid Recovery Interim Actions

From 1987 to 1991, GeoEngineers conducted LNAPL recovery operations in the Lower Yard. During this time, approximately 7,500 gallons of LNAPL were recovered from areas adjacent to the tidal basin and DB-1 (EMCON 1994). EMCON (1992 to 1998) and MFA (1999 and 2000) also conducted LNAPL recovery operations in the Lower Yard. During these periods, approximately 1,970 gallons of LNAPL were recovered from recovery wells in the Lower Yard (EMCON 1999 and MFA 2000). Additionally, in 1996 during remedial investigation activities, EMCON recovered approximately 8,600 gallons of LNAPL (EMCON 1998). Recovery operations primarily consisted of skimming, bailing, and pumping the product out of monitoring wells, as well as installing and operating two recovery well systems located along the northwest border of the Site (MFA 2001a). LNAPL recovery operations are summarized in Table 2-1.

2.5.2 Upper Yard Interim Action

The Upper Yard interim action was conducted between July 2002 and May 2003, in accordance with AO No. DE92TC-N328, and consisted of the excavation of petroleum-impacted soil, metals-impacted surface soil, and asphalt/polyurethane coating material. Approximately 113,034 tons of petroleum-impacted soil, 7,320 tons of metals-impacted soil, and 4,021 tons of asphalt/polyurethane coated material were excavated and removed from the Upper Yard (MFA 2003a).

Model Toxics Control Act (MTCA) Method B CULs of 200 milligrams per kilogram (mg/kg) for gasoline range organics (GRO), 460 mg/kg for diesel range organics (DRO), and a combined 2,959 mg/kg for TPH in all ranges (GRO, DRO, and heavy oil range organics [HO]) were used for petroleum-impacted soil in the Upper Yard. A total

of 842 confirmation samples were collected along the floors and sidewalls of the excavation areas. Confirmation samples containing concentrations exceeding the Method B CULs triggered additional excavation. At the final extent of each excavation area, no confirmation samples exceeded the Method B CULs for TPH (MFA 2003a).

A MTCA Method B CUL of 20 mg/kg for arsenic was used in metals-impacted surface soil excavation areas of the Upper Yard. A total of 500 metals confirmation samples were collected, which met the Method B CUL for arsenic. One confirmation sample exceeded the Method B CUL for arsenic, with a concentration of 48.1 mg/kg, which was associated with naturally occurring arsenic in the native soil. In 2003, 21 soil samples were collected to a maximum depth of 4 feet bgs and confirmed that arsenic is naturally present in the Upper Yard ramp area, where the concentration exceeds the Method B CUL. Additional information regarding the Upper Yard interim action is presented in the Upper Yard Interim Action As-Built Report (MFA 2003a). In October 2003, Ecology confirmed that Unocal had completed cleanup activities in the Upper Yard, and that the Upper Yard was suitable for residential use with regard to the soil direct contact pathway.

2.5.3 Lower Yard Interim Actions

2.5.3.1 2001 Excavation

In 1993, Unocal entered into AO No. DE92TC-N328 with Ecology. In 2001 Unocal conducted an interim action under the AO to remove LNAPL and petroleum-saturated soil and groundwater from four areas of the Lower Yard. These areas were located near the former railcar loading rack (Excavation A), former asphalt plant (Excavation B), and north-central area near the former slops pond (Excavations C and D) (Figure 2-1). Results of the 2001 interim action are summarized in the Lower Yard Interim Action As-Built Report (MFA 2001a).

Each excavation extended laterally until LNAPL-saturated soil was no longer observed on the excavation sidewalls, or until structural concerns would not allow further excavation. The excavation areas were left open for approximately 1 month to allow LNAPL to enter the excavations and be recovered. Final excavation depths ranged between 6.5 and 10.5 feet bgs (MFA 2002).

Soil samples were collected from the sidewalls of each excavation. However, the soil was not required to meet CULs or minimum concentration criteria because the purpose of the interim action was to remove LNAPL and visually petroleum-saturated soil. Excavated material from above the top of the smear zone was stockpiled and sampled for laboratory analysis. Stockpiles with soil concentrations of TPH less than

5,000 mg/kg were used as backfill material above the top of the smear zone (MFA 2002). Excavations B, C and D and the south part of the Excavation A were over excavated in 2007/2008 Excavation. In the area of Excavation A, soil samples containing concentrations greater than CULs/RELS (EX-A-6 and EX-A-7A containing concentrations greater than CULs/RELS with TPH concentrations of 6,680 mg/kg and 3,320 mg/kg respectively) were over-excavated as a part of these excavation activities.

The 2001 interim action resulted in the excavation and removal of 10,764 tons of LNAPL-saturated soil and 76,237 gallons of LNAPL and groundwater from these four areas of the Lower Yard (Figure 2-1).

2.5.3.2 2003 Excavation

Additional interim actions were conducted in 2003 under AO No. DE92TC-N328, including soil excavations in the southwest Lower Yard, DB-1, Metals Area 3 (located adjacent to the Southwest Lower Yard Excavation Area), and the Point Edwards Storm Drain Line Area (MFA 2004a). The interim action excavations conducted in the southwest Lower Yard, DB-1, and Metals Area 3 were implemented to reduce potential threats to human health and the environment, and to provide additional information for the feasibility study and design of the final cleanup action (MFA 2004a). The Point Edwards Storm Drain Line Area Excavation was conducted to remove contaminated soil along the alignment of a new storm drain for the Point Edwards condominium complex prior to its installation (Figure 2-1).

Depths of each excavation area were approximately 6 feet bgs in DB-1, 7.5 feet bgs (up to 1.5 feet below the groundwater table) in the southwest Lower Yard, 1 foot bgs in Metals Area 3, and 8.5 feet bgs in the Point Edwards Storm Drain Line Area (MFA 2004a).

The lateral extents of the excavations were identified by a REL for TPH (GRO, DRO, and HO) of 3,000 mg/kg and an arsenic CUL of 20 mg/kg. Soil samples were collected along the sidewalls and floors of each excavation area, except those areas that extended below the groundwater table, where floor samples were not collected (the Southwest Lower Yard Excavation Area). Laboratory analysis of soil samples at the extents of the excavations indicated that soil containing concentrations greater than CULs was left in place in two locations in DB-1, five locations in the southwest Lower Yard, and two locations in the Point Edwards Storm Drain Line Area. These locations were addressed during remedial excavations in 2007 and 2008. Soil sample location SWLY-D-3 Wall-3.75 (a confirmation sample located in the southwest Lower Yard), contained a TPH concentration of 2,923 mg/kg which was below the Site REL for TPH applicable at that time (3,000 mg/kg), however it is greater than the current Site REL

for TPH of 2,775 mg/kg which was later revised and established for the Site in 2013 (ARCADIS, 2013c). Details for the soil sample location SWLY-D-3 Wall-3.75 are provided in Table 2-4. The Point Edwards Storm Drain Line Excavation was conducted to facilitate installation of a new stormwater outfall for Point Edwards, and was not specifically intended as a remedial action. Three sample locations from the Point Edwards Storm Drain Line Excavation (STRM-6FLOOR-7, STRM-4WALLE(2)-3 and STRM-2WALLE-3), contained concentrations of COCs exceeding applicable RELs/CULs (with TPH concentrations of 17,439 mg/kg, 15,388 mg/kg and 4,913 mg/kg respectively, benzene concentration of 54.9 mg/kg detected in STRM-6FLOOR-7 and cPAHs adjusted for toxicity (cPAHs TEQ) concentration of 0.56 mg/kg detected in STRM-4WALLE(2)-3). Soil from the STRM-2WALLE-3 location was over-excavated during Phase I/II excavation activities in 2007/2008. Soil sample locations STRM-6FLOOR-7, STRM-4WALLE (2) are described in Table 2-4.

During the 2003 interim action excavations, 39,130 tons of soil were excavated from DB-1, the southwest Lower Yard, Metals Area 3, and the Storm Drain Line Area; and approximately 1,861,520 gallons of groundwater were extracted from the DB-1 and southwest Lower Yard and treated on site. MFA (2004a) summarized the results of the 2003 interim action.

2.5.3.3 2007/2008 Excavation

The 2007/2008 interim action excavation activities were conducted in two phases from July 2007 to April 2008 (Phase I), and July to October 2008 (Phase II), in accordance with AO No. DE 4460 (SLR 2007b). Phase I interim actions consisted of removing 108,000 tons of petroleum-impacted soil for off-site disposal and approximately 9,700 gallons of LNAPL from the groundwater surface in open excavations.

During Phase I excavation activities, 438 confirmation soil samples were collected from the floors and sidewalls of the excavation areas for TPH analysis. The Site REL for TPH was 2,975 mg/kg and the Site cPAHs TEQ CUL was 0.14 mg/kg. CULs/RELs were met in 430 of 438 confirmation samples, and eight of the confirmation samples contained concentrations of COCs exceeding applicable CULs/ RELs. Soil was not over-excavated in the area where the eight confirmation samples were collected to preserve the integrity of on-site structures or due to Site constraints (ARCADIS 2009). Soil in the areas of two of these eight samples was over-excavated during Phase II activities; however, six of the locations were not over-excavated because of Site constraints. Four samples contained concentrations of COCs exceeding the applicable REL for TPH: EX-A2-Q-14-6 [3,060 mg/kg], EX-B18-VV-1-6SW [4,980 mg/kg], EX-A2-O-15-SSW-6 [7,540 mg/kg] and EX-A2-N-16-SSW-6 [7,550 mg/kg]. One sample contained concentration of COCs exceeding the applicable CUL for cPAHs: EX-B11-U-

10-SSW-5 [0.159 mg/kg]. One sample, EX-B20-M-17-SSW-6, contained concentrations of COCs exceeding both applicable CUL for cPAHs [0.166 mg/kg] and REL for TPH [15,700 mg/kg]. These six confirmation samples are described in Table 2-4.

In April 2008, 65 confirmation soil borings were completed in the southwest Lower Yard to confirm that the soil on the floor of the 2003 excavation (discussed in Section 2.6.3.2) met the CULs/RELS. Sixty-three of the 65 borings did not contain COC concentrations exceeding the CULs/RELS. The two borings with exceedances of the CULs/RELS were completed in a previously unexcavated area of the southwest Lower Yard, in the former location of the pipeline trestle. These two borings (SB-63 and SB-64) were over-excavated during Phase II excavation activities. Subsequent over-excavation confirmation soil samples contained concentrations of Site COCs less than applicable Site CULs and RELs.

At the completion of Phase I excavation activities, the excavation sidewall along the WSDOT stormwater line was demarcated with 20 thousandths of an inch thick plastic sheeting prior to backfilling. This sheeting extends from the ground surface (13.5 feet amsl) to approximately 7.5 feet amsl. Groundwater elevations in the vicinity of the sheeting, as measured at MW-511 and MW-512, have ranged from 5.5 to 9.14 feet amsl during the current groundwater monitoring program.

As part of Phase I activities, arsenic-impacted soil was excavated and removed from the southwest Lower Yard, beneath the former Unocal railroad trestle. This area contained arsenic-impacted soil associated with sandblasting of the pipelines prior to their removal, and was the only remaining metals-impacted area at the Site. This area was excavated to 2.5 feet bgs, where confirmation samples showed concentrations of arsenic less than the arsenic CUL of 20 mg/kg.

During Phase I construction activities, approximately 9,700 gallons of LNAPL were recovered and removed from the Site, and approximately 2 million gallons of groundwater were extracted, treated on site, and discharged to Willow Creek under a NPDES permit. Results of the 2007/2008 Phase I interim actions are summarized in Phase I Remedial Implementation As-Built Report (ARCADIS 2009).

Phase II interim action work was performed between July and October 2008 and consisted of removing 14,825 tons of petroleum-impacted soil for off-site disposal, removing 131 gallons of LNAPL, removing and treating approximately 520,000 gallons of groundwater, and removing 2,000 tons of sediment from Willow Creek. The excavation areas for Phase II were based on areas of the Lower Yard that could not be excavated during Phase I and areas where impacts were discovered during 2008

investigation activities (see Section 2.7.1). These areas included the northwest perimeter of the Site adjacent to Willow Creek where three soil samples containing COC concentrations greater than Site CULs/RELs were left in place during Phase I activities, the southeast Lower Yard, and impacted soil in the Former Asphalt Warehouse Area (ARCADIS 2010a).

During Phase II, 71 confirmation soil samples were collected from the floors and sidewalls of the excavation areas. Seventy confirmation soil samples met the Site CULs/RELs and one confirmation sample (EX-B1-F-44-4) contained concentrations of cPAHs adjusted for toxicity (0.212 mg/kg) exceeding Site CULs. Soil in the area of this sample was not over-excavated during Phase II due to a calculation error in the field. This sample was collected from the southeast Lower Yard. Approximately 850 tons of concrete and metal debris were excavated from the southeast Lower Yard, including pilings, footings, large concrete blocks, scrap metal, steel I-beams, sheet metal, metal wiring, and lumber debris. In addition, approximately 18 steel drums and drum remnants were encountered in this area, some of which were filled or coated with tar-like substances. Much of this excavation area contained large quantities of tar-like substances intermixed with soil and debris. This material was sent to a permitted solid waste landfill.

Phase II construction activities also included the removal of 2,000 tons of impacted sediment and subsequent restoration of approximately 420 feet of Willow Creek. The sediment removal in Willow Creek was conducted based on 2003 toxicity testing, during which three sampling locations in Willow Creek failed toxicity tests. Two of these locations (US-05 and US-07) were located near the Lower Yard's stormwater outfalls #001 and #002. Both locations were excavated during the sediment removal portion of the Phase II 2007/2008 excavation activities. Results of the 2007/2008 Phase II interim actions are summarized in Phase II Remedial Implementation As-Built Report (ARCADIS 2010a). Limits of excavation for all areas of the Phase I and II excavations, as well as quantities of soil removed, are presented on Figure 2-12. During Phases I and II of the 2007/2008 excavation activities, 512 confirmation soil samples were collected from sample locations at the final extent of the excavation areas. Results for the confirmation soil samples are summarized below:

- Concentrations of TPH constituents (GRO, DRO, and HO) were less than laboratory detection limits in 261 of the 512 confirmation soil samples.
- Detected TPH concentrations were less than one-half of the former Site REL for TPH of 2,975 mg/kg in 227 of the 512 confirmation soil samples, and between one-half of the REL and the REL in 17 of the 512 confirmation soil samples.

- 7 of the 512 confirmation samples contained concentrations of COCs exceeding applicable CULs/ RELs, as described in Table 2-4:
 - Concentrations of TPH exceeded the former REL in five samples (EX-A2-Q-14-6 [3,060 mg/kg], EX-B18-VV-1-6SW [4,980 mg/kg], EX-A2-O-15-SSW-6 [7,540 mg/kg], EX-A2-N-16-SSW-6 [7,550 mg/kg], and EX-B20-M-17-SSW-6 [15,700 mg/kg]).
 - One sample with concentrations of TPH exceeded the former REL also exceeded the CUL for cPAHs adjusted for toxicity (EX-B20-M-17-SSW-6 [0.166 mg/kg]). Two additional samples exceeded the CUL for cPAHs adjusted for toxicity (EX-B11-U-10-SSW-5 [0.159 mg/kg] and EX-B1-F-44-4 [0.212 mg/kg]).
- Grid sampling on a 25-foot spacing of the floors and sidewalls confirmed that the lateral and vertical extents of soil impacts were addressed in all but two distinct areas of the Lower Yard (DB-2 and the WSDOT stormwater line area).
- The 2007/2008 interim action excavation areas included areas from the 2003 excavations that exceeded the TPH CUL and were not over-excavated in 2003.

2.6 Recent Investigations

2.6.1 2008 Lower Yard Site Investigation

In 2008, additional soil investigation activities were conducted to collect data and evaluate the nature and extent of limited remaining petroleum impacts in discrete areas of the Lower Yard, including areas to the south and southwest of the WSDOT stormwater line and the Former Asphalt Warehouse Area, near monitoring well MW-129R. Twenty-four soil borings were advanced in the Lower Yard to further delineate each of these areas.

Fourteen soil borings were advanced to the south and southwest of the WSDOT stormwater line, five (SB-65, SB-66, SB-68, SB-69 and SB-80) of which contained soil with concentrations of TPH and/or cPAHs exceeding Site CULs/RELs (with TPH concentrations ranging from 3,720 to 16,900 mg/kg and cPAHs TEQ ranging from 0.165 to 0.693 mg/kg). One location (SB-65-6.5) also exceeded benzene CUL with benzene concentration of 35.8 mg/kg). The five samples containing concentrations of TPH and/or cPAHs exceeding Site CULs/RELs are listed in Table 2-4. Three of these boring locations were located between the WSDOT stormwater line and the Point Edwards storm drain line, in the south-central portion of the Lower Yard. One boring

was located to the southwest of the Point Edwards storm drain line and one boring was located south of the WSDOT stormwater line where upper and lower Unoco Road meet.

Samples collected from three soil borings in the Former Asphalt Warehouse Area, which is located in the east-central portion of the Lower Yard, contained soil with concentrations of TPH and/or cPAHs exceeding Site CULs/RELs. Soil in the area of the soil borings located near the Former Asphalt Warehouse Area was excavated during Phase II excavation activities. Results of the 2008 investigation activities are summarized in 2008 Additional Site Investigation and Groundwater Monitoring Report (ARCADIS 2010b). Soil sample locations and analytical results from 2008 soil investigation activities are presented on Figure 2-13.

From October 8 to October 14, 2008, ARCADIS supervised the installation of 29 on-site monitoring wells. One soil sample collected during these activities, MW-129R-7.0 exceeded the site REL for TPH (with a TPH concentration of 3,007 mg/kg). This sample is listed in Table 2-4.

2.6.2 2011 Lower Yard Site Investigation

In 2011, site investigation activities conducted in the Lower Yard included a tidal study, hydraulic conductivity testing, and soil boring advancement in the limited area of impact near DB-2. Tidal study data were collected from 17 locations in monitoring wells at the Site and staff gauges in Willow Creek to evaluate the potential influence of Puget Sound and Willow Creek on surface water and groundwater gradients at the Site, and groundwater chemistry. Hydraulic conductivity pumping tests, including step tests, short-duration tests, and one long-term test, were conducted in 10 monitoring wells at the Site.

Soil investigation activities included the advancement of 17 soil borings (B-1 to B-17) and installation of nine piezometers (P-9 to P-16) near DB-2, monitoring well MW-510, and Willow Creek. These areas were investigated to assess the recurring, but minimal amount of LNAPL present in monitoring well MW-510. LNAPL was not encountered in nine of the 17 borings, but was encountered in eight of the 17 soil borings at the time of installation as either residual or free-phase LNAPL. Free-phase LNAPL subsequently appeared in two of the piezometers (P-12 and P-13) in 2011 and in a third one in 2013 (P-15). Soil containing concentrations of COCs exceeding their respective CULs and/or RELs was encountered in 11 of the soil borings (B-4 to B-11, B-13, B-16 and B-17) (with TPH concentrations ranging from 4,413 to 220,400 mg/kg and cPAHs TEQ ranging from 0.1 to 116 mg/kg). Details of the 2011 site investigation activities are summarized in the 2011 Site Investigation Completion Report (ARCADIS 2012a). Soil

sample locations and analytical results from the 2011 soil investigation activities are presented on Figure 2-14. The 11 samples containing concentrations of TPH and/or cPAHs exceeding Site CULs/RELs are listed in Table 2-4.

2.6.3 2012 Lower Yard Investigation

In 2012, eight monitoring wells were installed in the Lower Yard to assess groundwater conditions in areas of known and potential remaining soil impacts. Four wells (MW-525, MW-526, MW-531, and MW-532) were installed to the north and south of the WSDOT stormwater line to monitor for the possible presence of LNAPL and dissolved-phase TPH concentrations in groundwater in the unexcavated soil in this area. Specifically, wells MW-525, MW-526, and MW-532 were installed in previously impacted soil that was not removed during remedial interim actions. Monitoring wells MW-527 and MW-528 were installed in the southeast Lower Yard, near the one confirmation soil sample that contained cPAH concentrations exceeding the CUL. Monitoring wells MW-529 and MW-530 were installed on the southeast bank of Willow Creek, directly downgradient of monitoring wells MW-510 and LM-2, respectively. These wells were installed to monitor the potential for contaminant migration in groundwater off site into Willow Creek. Soil samples collected during monitoring well installation contained concentrations of benzene, cPAHs, and/or TPH exceeding site CULs/RELs in MW-525 and MW-532 only (with respective TPH concentrations of 17,850 and 10,540 mg/kg and cPAHs TEQ of 0.29 mg/kg in MW-525 only). Monitoring well locations and soil sample analytical data from 2012 site investigation activities are presented on Figure 2-15. The two samples containing concentrations of TPH and/or cPAHs exceeding Site CULs/RELs are listed in Table 2-4.

In July 2012, three sediment samples were collected from Willow Creek to assess sediment toxicity conditions near the 2003 sediment sampling location US-15. Based on the evaluation of these data, Ecology confirmed that further cleanup of Willow Creek was not needed (Ecology, 2003). Sediment sampling locations and analytical results are presented on Figure 2-16. Results of the 2012 investigation activities are summarized in Final CSM (ARCADIS 2013a).

2.6.4 2013 Soil Vapor Investigation

Soil vapor sampling was conducted in October and November 2013 in selected locations to evaluate worst-case scenario vapor intrusion and to support remedial strategy decisions at the Lower Yard. The sampling locations were selected in areas of highest TPH concentrations remaining in soil. These locations represent undisturbed soil in areas where remediation was not conducted. The remaining areas of the Lower Yard were previously excavated and backfilled with clean material. Therefore, the data

collected from these locations are not considered indicative of site-wide conditions. Soil vapor analytical results are presented in Table 2-6. Soil vapor probe locations and analytical results are presented on Figure 2-17, respectively. Soil vapor sampling procedures and chemical analytical data are presented in Appendices B and C respectively.

2.6.4.1 Soil Vapor Probe Installation

ARCADIS installed three permanent single-level on-site soil vapor probes (VP-1, VP-2, and VP-3) on October 8, 2013 in accordance with the approved Soil Vapor Investigation Work Plan (ARCADIS 2013b) to assess the potential for soil vapor in the Lower Yard adjacent to remaining impacts in soil and groundwater.

The vapor probe locations are near areas of maximum TPH detection and/or areas of remaining impacts on site to represent worst-case scenarios for volatile organic compounds (VOCs) and GRO:

- Soil vapor probe VP-1 is located near MW-525 (TPH [17,850 mg/kg], GRO [1,400 mg/kg]) to evaluate potential soil vapor adjacent to the WSDOT stormwater line.
- Soil vapor probe VP-2 is located near B-7 (TPH [111,400 mg/kg], GRO [1,400 mg/kg]) to evaluate potential soil vapor adjacent to DB-2 and groundwater monitoring well MW-510 (LNAPL observed).
- Soil vapor probe VP-3 is located adjacent to monitoring well MW-129R (TPH [3,007 mg/kg], GRO [nondetect]) to evaluate potential soil vapor in the adjacent area.

Continuous soil samples were collected for field screening from a hand auger at each soil vapor probe location during advancement. The collected intervals were screened in the field using a photo ionization detector (PID) and were described by the supervising geologist using visual and manual methods of the Unified Soil Classification System.

2.6.4.2 Soil Vapor Sampling

Soil vapor samples were collected on October 9, 2013; however, soil vapor data collected during this sampling event are considered questionable and not considered for the evaluation because VOC concentrations were detected in quality control samples. Soil vapor samples were collected again on November 21, 2013 in accordance with the Chevron ToolKit and ARCADIS Standard Operating Procedure

listed in Appendix B. The November 2013 soil vapor sampling data were used for evaluation of soil vapor quality in the remaining impact areas.

TPH was not analyzed because this compound is not directly comparable to Method B CULs presented in the Draft Guidance for Evaluating Soil Vapor Intrusion in Washington State: Investigation and Remedial Action (VI Guidance; Ecology 2009).

2.6.4.3 Soil Vapor Analytical Results

Soil vapor data from the November 2013 vapor sampling event were compared to health-based screening criteria (Ecology Method B soil gas screening levels presented in Table 2-5 of the VI Guidance [Ecology 2009]). These screening criteria define levels that the regulatory agencies have deemed safe for human exposure under a vapor intrusion scenario. Ecology provides draft soil gas screening values for samples collected at depths of less than 15 feet bgs and soil gas screening values for samples collected at 15 feet bgs or deeper.

Table 2-5. Soil Vapor Data Screening Levels

Compounds of Concern	Laboratory Reported Compounds	Method B Shallow Soil Gas Screening Levels (µg/m ³)
Benzene	Benzene	3.2
Naphthalene	Naphthalene	14
Air-phase petroleum hydrocarbons (APH) aliphatic (C5-C8)	Volatile petroleum hydrocarbons (VPH) aliphatic (C5-C6 + >C6-C8)	27,000
APH aliphatic (C9-C12)	VPH aliphatic (>C8-C10 + >C10-C12)	1,400
APH aromatic (C9-C10)	VPH aromatic (>C8-C10)	1,800

Concentrations of aliphatic carbon ranges C5-C6 + >C6-C8 were detected greater than screening criteria in the samples collected from VP-1(35,000,000 µg/m³), VP-2 (33,700 µg/m³), and VP-3 (529,000 µg/m³). Concentrations of aliphatic carbon ranges >C8-C10 + >C10-C12 were detected greater than screening criteria in the sample collected from VP-1 (6,600,000 µg/m³), VP-2 (36,000 µg/m³), and VP-3 (305,000 µg/m³).

Concentrations of aromatic carbon range >C8-C10 was detected greater than screening criteria in the sample collected from VP-1 (34,000 µg/m³). Concentrations of

benzene were detected greater than screening criteria in the samples collected from VP-1 (710,000 $\mu\text{g}/\text{m}^3$), VP-2 (340 $\mu\text{g}/\text{m}^3$), and VP-3 (46 $\mu\text{g}/\text{m}^3$). Concentrations of aromatic carbon ranges >C8-C10 were detected greater than screening criteria in the sample collected from VP-1 (34,000 $\mu\text{g}/\text{m}^3$). Due to sample dilution, the laboratory reporting limits (LRLs) for the analysis of naphthalene in all samples were greater than the respective MTCA screening criteria. Laboratory analytical results are included in Appendix C and in Table 2-6.

The soil vapor locations tested had one or more chemical concentrations exceeding the soil vapor screening level.

3. Nature and Extent of Contamination

This section describes the type of contaminants at the Site (nature) and the distribution of these contaminants vertically and horizontally across the Site (extent). The nature and extent of contamination were identified based on data collected during the remedial investigation (RI) (MFA 2001b), the supplemental remedial investigation (SRI) (MFA 2003b), 2008 site investigations (ARCADIS 2010b), 2011 site investigations (ARCADIS 2012a), 2012 site investigations (ARCADIS 2013a), and 2013 vapor sampling conducted as part of the interim action.

The primary COCs in the Lower Yard are petroleum hydrocarbons. During Lower Yard investigation activities conducted from 2001 to 2012, soil, groundwater, sediment, and surface-water samples were analyzed for GRO, DRO, and/or HO. Selected samples were also analyzed for benzene, toluene, ethylbenzene, and total xylenes (BTEX); polycyclic aromatic hydrocarbons (PAHs); and volatile and extractable petroleum hydrocarbon (VPH/EPH) fractions.

Prior to the 2001 and 2003 Lower Yard interim action excavations, LNAPL was present in six areas of the Lower Yard (near the southwestern former railroad loading rack area, near the northeastern former truck loading rack area, beneath the northeastern-most office building, beneath the former asphalt plant, to the north-northeast of the former asphalt plant, and to the south-southwest of DB-1) (MFA 2001a). Petroleum hydrocarbon constituents in the soil and dissolved in groundwater were present, primarily near the LNAPL areas and in areas where residual LNAPL was trapped in the unsaturated zone above the groundwater table. Prior to the 2003 interim action, petroleum hydrocarbons were present in soil and groundwater throughout the Lower Yard and DB-1.

After completion of the Phase I and II interim actions in 2007 and 2008, only localized known areas of impacted soil with concentrations exceeding cleanup levels remain along the WSDOT stormwater line and near DB-2. During the pre-2008 Lower Yard investigation activities, selected soil, groundwater, sediment, and surface-water samples were analyzed for metals (arsenic, antimony, cadmium, chromium, copper, lead, mercury, and zinc). Soil and groundwater beneath the Lower Yard contained concentrations of metals. Low concentrations were also detected in sediment and surface water from Willow Creek and the tidal basin. The highest metals concentrations in soil were present in areas associated with sandblast grit and paint chips occurring near pipe runs in the southwest Lower Yard. The majority of the metals-impacted soil in the Lower Yard was removed during the 2003 interim action. During the 2007 and 2008 excavation activities, the remaining arsenic-impacted soil was removed from the Lower Yard. During the RI, the highest dissolved and total metals concentrations in

groundwater were present in isolated locations that typically were not associated with sources of metals. Based on the distribution of the metals concentrations, the sources of the metals in surface water and sediment appear to be impacted stormwater from on- and off-site sources. During a storm event in April 1996, metals were detected in stormwater samples from the Lower and Upper yards. The samples contained detectable concentrations of arsenic, chromium, copper, lead, and zinc (MFA 2001b).

The following sections describe the nature and extent of contamination, primarily the COCs that were screened for the Lower Yard during development of the Draft Feasibility Study (Draft FS [MFA 2004c]). These contaminants are: TPH (combined GRO, DRO, and HO); benzene, chrysene, arsenic, and toxicity-adjusted total cPAHs for soil and TPH (combined GRO, DRO, and HO); benzene, chrysene, and toxicity-adjusted total cPAHs for groundwater and protection of surface water.

3.1 Soil Quality

Rigorous soil sampling activities were completed in locations throughout the Lower Yard and limited soil investigation was conducted in off-site locations (to the west and northwest of the Site). The soil samples were collected as part of several site investigations, including the 2008 additional site investigation (ARCADIS 2010b), 2011 site investigation (ARCADIS 2012a), RI (MFA 2001b), SRI (MFA 2003b), 2003 assessment (MFA 2004b), and investigations that were conducted prior to the RI and are described in the Background History Report (EMCON 1994). Soil samples were also collected as part of the 2001 and 2003 interim actions (MFA 2002 and 2004a).

The vertical and lateral distributions of petroleum hydrocarbons, benzene, chrysene, and arsenic in soil are presented in the Draft FS (MFA 2004c). All COCs except petroleum hydrocarbons were profiled at depths from ground surface to greater than 6 feet bgs. The distribution of petroleum hydrocarbons was profiled in three depth intervals: 0 to 3, 3 to 6, and greater than 6 feet bgs (MFA 2004c).

3.1.1 Petroleum Hydrocarbons

Historically, gasoline, diesel, and heavy oil were stored and used at the terminal. The TPH concentrations observed in soil are a mixture of GRO, DRO, and/or HO in varying proportions; therefore, this section discusses TPH (combined GRO, DRO, and HO concentrations) and not the individual product ranges. Prior to the 2007/2008 Phase I interim action activities, TPH was present in the shallow soil above the groundwater table throughout most of the Lower Yard (MFA 2004c). Generally, the areas of TPH-impacted soil coincided with historical terminal operations conducted in the former asphalt plant, and fuel storage and distribution areas, except the southeastern Lower

Yard. The southeastern Lower Yard was used as a waste soil stockpile area for material removed from two local Unocal service stations (EMCON 1994).

The 2001 interim actions removed impacted soil from four areas of the Lower Yard: near the former railcar loading rack (Excavation A), near the former asphalt plant (Excavation B), and in the north-central area near the former slops pond (Excavations C and D) (Figure 2-1). Each excavation extended laterally until LNAPL-saturated soil was no longer observed on the excavation sidewalls, or until structural concerns would not allow further excavation. Final excavation depths ranged between 6.5 and 10.5 feet bgs (MFA 2002). Excavation confirmation soil samples collected during the 2001 interim actions contained TPH concentrations ranging from 724 to 3,203 mg/kg. Soil samples were collected from the sidewalls of each excavation although no CULs or minimum concentration criteria were required to be met. Excavated material from above the top of the smear zone was stockpiled and sampled for laboratory analysis. Stockpiles with soil concentrations of TPH less than 5,000 mg/kg were used as backfill material above the top of the smear zone (MFA 2002).

The 2003 interim actions removed impacted soil from DB-1, the Point Edwards storm drain line, Metals Area 3 (located adjacent to the Southwest Lower Yard Excavation Area), and the southwest Lower Yard. Depths of each excavation area were approximately 6 feet bgs in the DB-1 Excavation, approximately 7.5 feet bgs (up to 1.5 feet below the groundwater table) in the Southwest Lower Yard Excavation Area, approximately 1 foot bgs in the Metals Area 3 Excavation, and approximately 8.5 feet bgs in the storm drain line excavation (MFA 2004a). Lateral extents of the excavations were identified by COC concentrations in soil samples collected along the sidewalls and floors of each excavation. Concentrations of TPH ranged from less than laboratory detection limits to 17,439 mg/kg in these samples.

Prior to 2007/2008 interim action excavation activities, soil containing TPH greater than 5,000 mg/kg at depths from ground surface to greater than 6 feet bgs were found throughout the majority of the Lower Yard. Areas of remaining impacted soil included the central and south-central Lower Yard (location of the former asphalt plant and northern truck loading rack area), northwestern property boundary adjacent to Willow Creek (former asphalt plant area), southwest property boundary adjacent to the BNSF Railway right-of-way (former railcar loading areas and southern truck loading rack), and southeast Lower Yard. Areas with elevated concentrations of TPH in the Lower Yard also included 2001 interim action Excavations B, C, and D, and under the stormwater excavation, adjacent to Excavation A (Figure 2-1).

Prior to 2007/2008 interim action excavation activities, maximum concentrations of TPH were found at depths from 0 to 3 feet bgs in the north-central Lower Yard (31,600

mg/kg), from 3 to 6 feet bgs in the south-central Lower Yard (147,230 mg/kg), and at depths greater than 6 feet bgs in the southeast Lower Yard (18,852 mg/kg). TPH impacts were most laterally extensive at depths from 3 to 6 feet bgs throughout the Lower Yard (SLR 2007a).

Areas excavated during the 2007/2008 interim actions are shown on Figure 2-12. These areas cover the majority of the Lower Yard, including the western boundary of the southwest Lower Yard, the majority of the central and west-northwestern Lower Yard, and the southeastern Lower Yard. Excavation areas from the 2003 interim actions were re-excavated at this time, except the Point Edwards storm drain line area and DB-1. Excavation depths ranged from 4 to 15 feet bgs. Limits of excavation extended until LNAPL-saturated soil was removed and confirmation soil samples collected at the extent of the excavation were less than the former site REL of 2,975 mg/kg. TPH concentrations in soil samples collected during the 2007/2008 interim action excavations ranged from less than laboratory detection limits to 17,100 mg/kg. In general, maximum remaining concentrations of TPH are generally found along the WSDOT stormwater line.

The majority of remaining hydrocarbon impacts in soil occur in two localized areas of the Lower Yard: The WSDOT stormwater line and DB-2. Concentrations of TPH remaining in the WSDOT stormwater line range from 3,060 to 16,900 mg/kg, at depths between 4 and 8 feet bgs. This includes soil sample location SB-80 from 2008 along the Point Edwards storm drain line (4,660 mg/kg TPH) at 7.5 feet bgs.

Soil samples collected in the DB-2 area contain residual LNAPL in some areas and concentrations of TPH ranging from 4,413 to 220,400 mg/kg in some areas. Impacts are found between 4 to 14 feet bgs in the DB-2 area.

Remaining TPH impacts are also present in two sample locations in the southwest Lower Yard (2,923 and 4,980 mg/kg TPH) at 3.75 and 6 feet bgs, respectively; and in monitoring well MW-129R (3,007 mg/kg TPH) at 7 feet bgs. As part of the RI activities conducted by EMCON in 1995, five monitoring wells (MW-105, MW-106, MW-107, MW-137, and MW-138) were installed in the BNSF Railway right of way, between the southwest Lower Yard property boundary and the BNSF Railway line. TPH concentrations in the soil samples collected during well installation were generally less than the laboratory detection limits. The maximum TPH concentration in soil was 230 mg/kg in MW-105, collected at 1 foot bgs (EMCON 1998). No soil concentrations in these samples were greater than site-specific CULs for the Lower Yard.

Concentrations of TPH in the soil samples located northwest of the Site (off site) were less than 500 mg/kg, except samples from two borings located in Admiral Way (SB-1

and SB-4). Samples from SB-1 and SB-4 contained TPH concentrations of up to 2,694 and 3,203 mg/kg, respectively (MFA 2003b)). Based on the localized distribution of impacted soil beneath Admiral Way and the low to nondetect petroleum hydrocarbon concentrations in soil and/or groundwater samples from the borings/wells (MW-28, MW-106, and MW-107) located between the Lower Yard and Admiral Way, it appears that the impacted soil beneath Admiral Way is from off-site sources (MFA 2003b).

3.1.2 Benzene

Prior to the 2007/2008 interim action excavations, benzene in soil was present in localized areas of the Lower Yard. Benzene concentrations exceeding 1 mg/kg were present in localized areas in the southeastern, central, and west-northwestern parts of the Lower Yard. Areas of the Lower Yard where benzene concentrations existed typically also contained elevated concentrations of TPH. The maximum detected concentration of benzene in soil in the Lower Yard was 78 mg/kg. Benzene in soil was not detected at concentrations greater than laboratory detection limits in samples collected during the off-site soil investigation, to the northwest of the Site.

Benzene concentrations detected in confirmation soil samples during the 2007/2008 interim action excavation ranged from less than laboratory detection limits to 14.90 mg/kg. The sample containing the highest concentrations of benzene was collected from the excavation sidewall, adjacent to the WSDOT stormwater line in the south-central portion of the Lower Yard and was not over-excavated to avoid damage to the WSDOT stormwater line. During the additional soil investigation activities in 2008, only one of the twenty four soil samples (SB-65, located south of the WSDOT stormwater line) contained a benzene concentration (35.8 mg/kg) exceeding the Site-specific benzene CUL of 18 mg/kg. In 2012, monitoring wells MW-525, MW-526, and MW-532 were installed along the WSDOT stormwater line in soil that was not disturbed during prior excavation activities. One soil sample collected from the boring for well MW-525 at a depth of 6 feet bgs contained a benzene concentration of 34 mg/kg. The soil sample collected from SB-65 contained the highest benzene concentration in soil that has been detected in the Lower Yard during or after the 2007/2008 interim action excavations. Sample locations MW-525 and SB-65 were the only soil samples to exceed the Site-specific benzene CUL of 18 mg/kg.

3.1.3 Carcinogenic Polyaromatic Hydrocarbons

Prior to the 2007/2008 interim action excavations, cPAHs were found in large areas beneath the central and eastern-southeastern parts of the Lower Yard, and in more localized areas beneath the northern and western-southwestern parts of the Lower Yard (MFA 2004c). Areas of cPAH concentrations typically contained elevated

concentrations of TPH. Since the 2007/2008 interim action excavations, cPAH concentrations adjusted for toxicity in soil detected in the Lower Yard have ranged from less than laboratory detection limits to 116 mg/kg (with a laboratory flag indicating GC/MS semivolatiles internal standard peak areas were outside of the QC limits). The maximum concentration of total cPAHs TEQ detected during the 2007/2008 interim action activities was 1.14 mg/kg in a sample collected from the southeast Lower Yard. This sample location was later over-excavated. Three soil sample locations with concentrations of cPAHs exceeding the Site TEQ CUL of 0.14 mg/kg remained after the 2007/2008 interim actions. Two of these sample locations were located on the excavation sidewall along the WSDOT stormwater line at depths of 5 and 6 feet bgs, with TEQ concentrations of 0.16 and 0.17 mg/kg, respectively, and one was located in the southeast Lower Yard at a depth of 4 feet bgs, with a TEQ concentration of 0.21 mg/kg.

During 2011 site investigation activities in the DB-2 area, TEQ concentrations of cPAHs were detected at concentrations ranging from less than laboratory detection limits to 116 mg/kg (with a laboratory flag indicating GC/MS semivolatiles internal standard peak areas were outside of the QC limits). Concentrations were detected greater than the Site CUL in eight borings. Thirteen soil samples contained concentrations of cPAHs greater than the Site CUL, at depths ranging from 0.5 to 14 feet bgs. TEQ concentrations of cPAHs greater than the Site CUL ranged from 0.14 to 116 mg/kg, which is the highest concentration of cPAHs currently found in the Lower Yard.

3.1.4 Arsenic

Arsenic was identified as the only metal IHS in soil in the Lower Yard. The majority of arsenic-impacted soil in the Lower Yard was removed during the 2003 interim action. Upon completion of the 2003 interim action, arsenic was present only at concentrations greater than 20 mg/kg in the southwestern corner of the southwestern Lower Yard. The maximum arsenic concentration in this area was 1,900 mg/kg.

During the 2007/2008 interim action excavations, the arsenic-impacted area of the southwestern Lower Yard was excavated and confirmation samples were collected. Confirmation samples in one sample location exceeded the CUL of 20 mg/kg, with concentrations of 25, 30.7, and 30.9 mg/kg. These samples were over-excavated and one confirmation sample with a concentration of arsenic less than laboratory detection limits was collected. Arsenic concentrations in soil exceeding the CUL are no longer found in the Lower Yard.

3.2 Soil Vapor Quality

As discussed in Section 2.7.4, ARCADIS conducted a limited soil vapor assessment to represent worst-case scenarios for VOCs. Three vapor probes (VP-1, VP-2, and VP-3) were installed at a depth of 5 feet bgs near areas of maximum TPH detection and/or areas of remaining impacts at the Site.

The soil vapor concentrations at all three locations exceeded applicable cleanup levels for one or more chemicals:

- *Near the WSDOT stormwater line.* Soil vapor concentrations analyzed in samples collected from VP-1 exceeded applicable screening levels for benzene, naphthalene, analyzed vapor-phase hydrocarbon aliphatic carbon ranges, and >C8-C10 vapor-phase hydrocarbon aromatic carbon ranges.
- *Near DB-2.* Soil vapor concentrations analyzed in samples collected from VP-2 exceeded applicable screening levels for benzene, naphthalene, and analyzed vapor-phase hydrocarbon aliphatic carbon ranges.
- *MW-129 R.* Soil vapor concentrations analyzed in samples collected from VP-3 exceeded applicable screening levels for benzene, naphthalene, and analyzed vapor-phase hydrocarbon aliphatic carbon ranges.

Based on the limited soil vapor assessment conducted at the Site, the three locations tested indicate there is potential for soil vapor to cause exceedances of applicable screening levels. As described earlier in Section 2.7.4, these locations were selected in areas of the highest remaining TPH concentrations in soil, and are considered as worst case scenarios and do not represent the entire Site. The data obtained from 2013 soil vapor assessment indicates soil vapor hazard exists in these discrete areas which have not been excavated or remediated. Additional assessment of potential soil vapor intrusion hazards will be conducted in other areas of the Lower Yard. These soil vapor probes will be installed to obtain data to further assess potential soil vapor hazards at the Site. Additional details are provided in Section 7.

3.3 Light Nonaqueous Phase Liquid

Prior to the 2001 interim action, seven main areas of LNAPL were identified beneath the Lower Yard. These areas were the four areas included in the 2001 excavations (Excavations A through D), plus the southwest Lower Yard property boundary and the former asphalt plant area, south of the detention basins, and in the central Lower Yard (MFA 2004c).

From 1987 to 2000, approximately 18,070 gallons of LNAPL were recovered as part of interim action product recovery activities, as discussed in Section 2.6.1. During the 2001 interim action, an additional estimated 2,500 gallons of product were removed from the excavation areas (MFA 2002). LNAPL has never been observed seeping into the tidal basin or Willow Creek, or detected in the off-site monitoring wells located in the BNSF Railway right of way, adjacent to the southwest Lower Yard. In September 2006, prior to the 2007/2008 excavation, SLR conducted a groundwater sampling event at the Lower Yard (SLR 2006) and identified four distinct areas of LNAPL. These areas were in Excavation A (adjacent to the tidal basin), southeast of Excavation B (in the central Lower Yard), Excavation D in the west/northwestern area (south of DB-2), and the central portion of the Lower Yard between DB-1 and lower Unoco Road. Dissolved-phase impacts were not found in the southwest or southeast Lower Yard, or north of DB-1 (SLR 2007a).

Since the 2007/2008 interim action excavation activities, LNAPL on groundwater has been present in only two areas. LNAPL was observed in well MW-129R at a thickness of 0.01 foot in February 2009, but has not been observed since. LNAPL on groundwater has been present in the DB-2 area in four wells (MW-510, P-12, P-13, and P-15). Monitoring well MW-510 and piezometers P-12 and P-13 are located 15 feet apart in the DB-2 area. Piezometer P-15 is located approximately 70 feet to the north of MW-510, P-12, and P-13, adjacent to DB-1 and DB-2. LNAPL amounts in the DB-2 area wells are summarized below:

- Monitoring well MW-510 has had measurable amounts of LNAPL during nine sampling events since October 2009, with thicknesses ranging from 0.01 to 0.13 foot.
- Piezometer P-12 has had measurable amounts of LNAPL during seven of the last 18 gauging events, with thicknesses ranging from 0.01 to 0.09 foot.
- Piezometer P-13 has had measurable amounts of LNAPL during 14 of the last 18 gauging events, from August 2011 to June 2014, with thicknesses ranging from 0.01 foot to 1.35 feet.
- Piezometer P-15 has had measurable amounts of LNAPL during five of the past 18 gauging events, from August 2011 to June 2014, with thicknesses ranging from 0.06 to 0.14 foot.

3.4 Groundwater Quality

The CSM presented in the IAWP – Lower Yard (SLR 2007a) concluded that groundwater beneath the Site discharges to surface water and sediment in Willow Creek. As a result, the IAWP – Lower Yard (SLR 2007a) establishes groundwater CULs based on the protection of surface water. According to the AO, groundwater CULs are required to be met at the perimeter monitoring wells, which are located along the downgradient perimeter of the Site, where groundwater discharges to surface water. Data collected from the interior monitoring well locations were not used to assess compliance during the interim action; rather, the dissolved concentration data collected at interior monitoring well locations have historically been used to evaluate groundwater concentration trends at the Site and overall plume stability.

In accordance with the AO, groundwater monitoring was initiated and is ongoing following completion of the 2007/2008 interim action activities. Groundwater flow paths were established within the interior of the Lower Yard, and each groundwater flow path consisted of seven monitoring wells (one upgradient well, three source area wells, and three downgradient wells). Perimeter wells were established at the point where groundwater discharges to surface water within the monitoring well network, located along the downgradient perimeter of the Site. Seventeen perimeter wells were originally established in the IAWP – Lower Yard (SLR 2007a); currently, 23 perimeter wells are present on site.

The locations of the wells inside the three groundwater flow paths were selected based on the presence of LNAPL on groundwater prior to remedial activities. Prior to the 2007/2008 interim action remedial excavations, the groundwater flow paths fit the established model of upgradient, source area, and downgradient wells. However, as a result of the 2007/2008 interim action, remedial excavations extended beyond the mapped flow path areas, and the resulting monitoring well arrangement was no longer suitable for use with Ecology's Natural Attenuation Analysis Tool Package A, as originally intended.

As a result of the source removal, the flow paths previously defined did not contain monitoring wells that could provide upgradient and downgradient water quality data in relation to specific source areas were no longer applicable for a spatial evaluation of natural attenuation away from the source, as required for use with Ecology's Natural Attenuation Analysis Tool Package A. This change in the CSM rendered the previous sampling schedule and monitoring program obsolete with respect to the planned data evaluation, and necessitated revisions to the monitoring program that were reviewed and approved by Ecology in December 2009. However, the current monitoring well network is sufficient to monitor and evaluate the status of the overall dissolved-phase

plume. The stability of the Site plume is being evaluated on a well-by-well basis, and the monitoring program needed to support this analysis was revised accordingly. At present, groundwater sampling events are conducted quarterly, with perimeter wells sampled during first and third quarter events, and all Site wells (perimeter and interior wells) sampled during second and fourth quarter events. However, per Ecology direction in a letter dated May 21, 2014, a conditional point of compliance at the property boundary cannot be used at the Site (Ecology, 2014a). Therefore groundwater compliance will need to be met throughout the property.

The following sections describe the current groundwater conditions in the Lower Yard.

3.4.1 Petroleum Hydrocarbons

A Site-wide groundwater sampling event was completed in June 2001, before the 2001 interim action was conducted. TPH was present in shallow groundwater throughout most of the western, northwestern, and central parts of the Lower Yard, and in localized areas beneath the southwestern, northern, eastern, and southeastern parts of the Lower Yard. In general, the areas of impacted groundwater beneath the Lower Yard coincided with historical facility operations (e.g., former asphalt plant and fuel storage and distribution areas).

Site-wide groundwater sampling events were conducted in February and August 2004 (i.e., after the 2003 interim action). The area of TPH-impacted groundwater in 2004 is similar to the impacted area in June 2001. Based on the results of the 2001 and 2003 interim actions, the TPH concentrations in August 2004 in wells located near Excavation B, the southwest Lower Yard, and DB-1 excavations were typically less than the concentrations in June 2001. Due to the continued presence of LNAPL in Excavations A and D, elevated TPH concentrations in groundwater remained near Excavations A, C, and D. Groundwater analytical results from the August 2004 sampling event indicated that samples collected from 13 wells at the Site, outside of the LNAPL areas, contained dissolved concentrations of TPH exceeding the Site-specific CULs at that time. TPH concentrations in the five off-site wells in the BNSF Railway right of way adjacent to the southwest Lower Yard were less than laboratory detection limits (SLR 2004a).

In September 2006, prior to the 2007/2008 excavation, SLR conducted a groundwater sampling event at the Lower Yard. Four distinct areas of LNAPL were interpreted to be present at this time. These areas were located in the 2001 Excavation A (adjacent to the tidal basin), southeast of Excavation B (in the central Lower Yard), Excavation D in the west/northwestern area (south of DB-2), and central portion of the Lower Yard between DB-1 and lower Unoco Road. Dissolved-phase impacts were not found in the

southwest or southeast Lower Yard, or north of DB-1 (SLR 2007a). Dissolved concentrations of TPH greater than Site-specific CULs were detected in six wells outside of the LNAPL areas during the 2006 groundwater sampling event. TPH concentrations in the five off-site wells in the BNSF Railway right of way adjacent to the southwest Lower Yard were less than laboratory detection limits (SLR 2006). Approximate concentration contours of TPH from this time are shown on Figure 3-1.

Compared to groundwater conditions prior to interim action activities in the Lower Yard (2006) (Figure 3-1), there has been a marked decrease in areas of LNAPL and a marked decrease in dissolved-phase TPH across the Site (2014) (Figure 3-2). Geochemical parameters monitored across the Site indicate that an environment that is conducive to anaerobic biodegradation of petroleum hydrocarbons is present and that biodegradation is likely ongoing at the Site. As of June 2014, four wells (MW-510, MW-518, MW-525 and MW-526) contained concentrations of dissolved-phase hydrocarbons exceeding sample-specific CULs during the past four sampling events (since September 2013). Maximum TPH concentrations in these samples, from September 2013 to June 2014, were 6,140 µg/L (MW-510), 947 µg/L (MW-518), 8,014 µg/L (MW-525) and 977 µg/L (MW-526). The second quarter 2014 (June) TPH concentrations are shown on Figure 3-3. Monitoring well MW-510 has not contained measurable thicknesses of LNAPL since December 2012, and groundwater samples have been collected since then. Well MW-510 is a perimeter well in a downgradient area of the Lower Yard. However, newly installed monitoring well MW-529, located approximately 20 feet downgradient of MW-510, has not contained dissolved concentrations of TPH greater than laboratory detection limits since its installation in June 2012. This supports the conclusion that Site groundwater is not impacting surface water at this location.

Wells MW-525 and MW-526 are interior monitoring wells installed along the WSDOT stormwater line in soil that was not disturbed during prior excavation activities. The monitoring wells downgradient of MW-525 (MW-104 and MW-20R) and MW-526 (MW-101 and MW-512 through MW-518) have not exceeded the TPH CULs since December 2013. These wells are located approximately 47 to 300 feet downgradient of MW-525 and MW-526 (MW-512 and MW-518, respectively).

Recent (post-2012) groundwater analytical data indicate that petroleum hydrocarbon concentrations are elevated in wells MW-525 and MW-526. These wells were installed in areas of known impacted soil that were not excavated during previous interim actions.

In June 2001 (before the 2001 interim action), dissolved-phase benzene concentrations were detected in shallow groundwater in localized areas in the western,

southwestern, northwestern, central, and eastern parts of the Lower Yard (MFA 2004c). Benzene was not detected in the northern and southeastern parts of the Lower Yard. Outside of the LNAPL areas, benzene concentrations greater than 20 micrograms per liter ($\mu\text{g/L}$) were present in the western part of the Lower Yard (near the northeastern former truck loading rack) and in the southwestern part of the Lower Yard (MFA 2004c).

After the 2003 interim action excavation activities, the August 2004 groundwater sampling results indicated that benzene concentrations decreased near Excavations B and C and in the southwest Lower Yard. Due to the continued presence of LNAPL after excavation was completed, elevated benzene concentrations remained in groundwater near Excavations A and D. In August 2004, areas outside of the LNAPL areas contained dissolved benzene concentrations greater than 20 $\mu\text{g/L}$ in four monitoring wells near Excavation A and in a localized area of the southwestern Lower Yard (SLR 2004a).

After completion of the 2007/2008 interim action excavation activities, and since the implementation of the current groundwater monitoring program in October 2008, dissolved-phase benzene concentrations have exceeded the Site CUL of 16 $\mu\text{g/L}$ in three monitoring wells. Perimeter monitoring well MW-20R, near the Point Edwards storm drain, and interior monitoring well MW-525, in the central Lower Yard, have respectively contained a maximum benzene concentration of 55 $\mu\text{g/L}$ and 5,900 $\mu\text{g/L}$. Perimeter monitoring well MW-510, in the DB-2 area, exceeded the CUL once in June 2009, with a concentration of 18 $\mu\text{g/L}$.

3.4.2 Carcinogenic Polycyclic Aromatic Hydrocarbons

Prior to the 2001 interim action excavations, dissolved-phase cPAHs were detected in one groundwater sample collected from one well (MW-8) in the Lower Yard. The sample from MW-8 contained an estimated cPAH concentration of 0.933 $\mu\text{g/L}$ (MFA 2004c). Groundwater sampling results from August 2004 showed that dissolved-phase cPAHs were detected in one groundwater sample collected from well MW-13U in the Lower Yard. The sample from MW-13U, which is located near the former garage, contained a chrysene concentration of 0.0135 $\mu\text{g/L}$ (MFA 2004c).

Since the implementation of the current groundwater monitoring program in October 2008, nine samples have exceeded the Site-specific CUL for cPAHs of 0.05 $\mu\text{g/L}$. However, seven of nine samples contained concentrations less than laboratory detection limits, but exceeded CULs due to raised detection limits. One sample collected from well MW-510 contained a concentration of 0.078 $\mu\text{g/L}$ in December

2012, exceeding the Site CUL. One sample collected from well MW-526 contained a concentration of 0.090 µg/L in December 2013, exceeding the Site CUL.

3.5 Surface Water

During the RI and SRI investigations and the 2003 assessment, and subsequent to the 2003 assessment, surface-water samples (SW-1 through SW-4 and SW-1A through SW-4) were collected from four locations in Willow Creek and the tidal basin in April 1996; September 2001; October 2003; and May, July, and August 2004 (MFA 2004c).

The April 1996 samples were collected during a storm event. In April 1996, the samples from Willow Creek and the tidal basin did not contain GRO, DRO, or HO concentrations greater than laboratory detection limits. The samples (SW-3 and SW-4) collected downstream from the Lower Yard stormwater outfalls contained toluene, ethylbenzene and total xylenes at concentrations up to an estimated 1 µg/L (EMCON 1998). SW-3 also contained pyrene at a concentration of 0.011 µg/L. The upstream (background) surface-water sample (SW-1) collected near the fish hatchery contained detectable concentrations of PAH compounds ranging from 0.017 µg/L for anthracene to 1.1 µg/L for fluoranthene. Arsenic, chromium, copper, lead, and zinc were detected in almost all of the samples, although the detections were estimated values due to the low concentrations (EMCON 1998).

During the 2001 and 2003 sampling events, GRO, DRO, HO, and BTEX constituents were not detected in the surface-water samples collected from Willow Creek or the tidal basin (MFA 2003b). PAHs and metals were not analyzed in the 2001 samples. In 2003, samples SW-1, SW-3, and SW-4 contained detectable concentrations of PAH compounds (including cPAHs) that ranged from 0.030 to 0.066 µg/L (MFA 2004b). Samples SW-3 and SW-4 contained total copper and total lead concentrations ranging from 12 to 19 µg/L; however, the dissolved copper and dissolved lead concentrations ranged up to only 1 µg/L (MFA 2004b).

One additional surface-water sampling event was conducted in 2004 to evaluate the source of the arsenic concentrations detected in 1996 at downstream sample locations SW-3 and SW-4. Using an analysis procedure to reduce interference from the brackish water in the sample, analytical results showed dissolved arsenic concentrations ranging from 1.4 to 2.1 µg/L and that the arsenic concentrations reflected upstream concentrations that flow into the area of the Site (SLR 2004b).

3.6 Sediment

In 1996, 15 sediment samples (US-01 through US-15) were collected from Willow Creek and the tidal basin, and two sediment samples were collected from off-site control locations. The samples were submitted for conventional analyses (e.g., grain size and total organic carbon) and bioassay testing. The bioassay testing results identified that sediment in Willow Creek produced effects on amphipod (*Eohaustarius estuaris*) survival, bivalve (*Mytilus edulis*) larvae survival and development, and juvenile polychaete (*Neanthes arenaceodentata*) development (MFA 2004c).

In 2003, 16 sediment samples were collected from locations US-1 through US-15 and one additional sample location (US-16), located between locations US-14 and US-15. These samples were analyzed using a suite of chemical analyses and bulk chemistry analyses, as summarized below:

- Elevated GRO and DRO concentrations were detected in 10 samples and elevated HO concentrations were detected in 13 samples. The greatest GRO concentration (59.1 mg/kg) was detected near the terminal's stormwater outfall #002 (sample US-07). The highest DRO and HO concentrations (1,470 and 5,480 mg/kg), respectively, were detected in the sample collected downgradient (northwest) of the former asphalt plant (sample US-04).
- PAH compounds (including cPAHs) were detected in several samples.
- VOCs and chlorinated hydrocarbons were not detected in any of the samples (MFA 2004b).
- Polychlorinated biphenyls (PCBs) were detected at a total concentration of 0.484 mg/kg (without normalization to organic carbon content) in sample US-07, collected near stormwater outfall #002 (MFA 2004b).
- Metals (arsenic, copper, zinc, lead, chromium, mercury, and silver) were detected in all 16 samples, with the highest concentration observed in upstream sample location US-16.

Due to elevated TPH concentrations, bioassay toxicity testing was conducted on sediment samples from six locations. The results of the sediment toxicity testing showed that the toxicity at two sample stations located near the Lower Yard outfalls into Willow Creek, adjacent to the OWS and DB-2 (US-05 and US-07), exceeded cleanup screening levels (CSLs). Sediment toxicity at the upstream (background)

station adjacent to the southeast Lower Yard (US-15) prevented use of this station as a reference station for two of the three bioassay test species.

The 2007/2008 interim action included the removal of sediment that failed bioassay tests due to discharges at outfall locations made during facility operations (at sample locations US-05 and US-07). After the 2007/2008 interim action, three sediment samples were collected from Willow Creek on July 30, 2012, to assess sediment toxicity conditions near 2003 sediment sampling location US-15, as described in the Final CSM (ARCADIS 2013a). Chemical analytical results for the sediment samples were evaluated to identify if bioassays should be performed on the samples. This determination was made by comparing the results to the Sediment Quality Standards (SQSs) presented in the Sediment Management Standards (SMSs; Chapter 173-204 Washington Administrative Code [WAC]) and CSLs. Based on an evaluation of the data, which showed that all results for the 2012 sediment samples were below the SMS SQS (Chapter 173-204 WAC) and CSL or lowest apparent effects threshold (LAET), ARCADIS suggested that bioassay testing was not necessary. On August 9, 2012, Ecology concurred that bioassay testing was not needed and that no further cleanup of Willow Creek is required unless Willow Creek subsequently becomes contaminated by remaining impacts at the Site (ARCADIS 2013a).

4. Conceptual Site Model

This section synthesizes the data collected during previous investigations and interim actions into a CSM of contaminant occurrence, movement, and potential exposures. The CSM is a tool used to develop CULs and remedial alternatives. The text presented in this section is also provided in the Final CSM (ARCADIS 2013a).

4.1 Source Characterization

As discussed in Section 2.2, the Lower Yard was only used by Unocal for office purposes after 1991. There are no continuing sources of hazardous substance releases at the Site. The historical primary sources of contamination in the Lower Yard are the former asphalt plant and the former fuel storage and distribution operations (aboveground tanks and piping, truck loading racks, and railroad loading rack).

Petroleum hydrocarbons (GRO, DRO, and HO) were likely released from the former asphalt plant and fuel storage and distribution activities. Petroleum-impacted materials from off-site sources were also stockpiled and stored in the southeastern Lower Yard. Arsenic impacts were traced to the use of sandblast grit containing arsenic, used during maintenance of aboveground tanks and piping. Off-specification asphalt from the asphalt plant was likely disposed of in DB-1 (EMCON 1994).

4.2 Remaining Impacts

Extensive investigation and remediation has been conducted at the Site, as described in Sections 2.5, 2.6, and 2.7. As the result of interim action excavation activities and confirmation sampling, multiple site investigations, and groundwater monitoring activities, each area of the Lower Yard containing soil, groundwater, or sediment with concentrations of COCs greater than applicable CULs is fully delineated. Each area containing soil or groundwater impacts is discussed below. Areas of the Lower Yard with remaining impacts are shown on Figures 4-1, 4-2, and 4-3.

4.2.1 Soil

The soil samples containing concentrations of COCs exceeding Site CULs/RELS are listed in Table 2-4 and shown on Figure 4-1.

4.2.1.1 *Washington State Department of Transportation Stormwater Line*

The WSDOT stormwater line runs across the Lower Yard, along lower Unoco Road, and out to Puget Sound. During the 2007/2008 interim action excavation activities,

impacted soil was encountered adjacent to the WSDOT stormwater line. Five soil samples collected on the excavation sidewalls adjacent to (and directly north of) the WSDOT stormwater line in the south-central portion of the Site contained concentrations exceeding Site CULs and/or RELs (ARCADIS 2009). These soil samples were collected at depths between 4 and 6 feet bgs, with concentrations of TPH ranging from 3,060 to 15,700 mg/kg. One of these samples also exceeded the CUL for cPAHs TEQ (0.14 mg/kg), with a concentration of 0.166 mg/kg. One additional sample exceeded the CUL for cPAHs TEQ (0.14 mg/kg), with a concentration of 0.159 mg/kg.

Soil along the WSDOT stormwater line, including soil with CUL/REL exceedances, was unable to be excavated with construction techniques available at the time of the interim action due to concerns about compromising the integrity of the line. Polyethylene sheeting was left in place to demarcate the excavation limits adjacent to the WSDOT stormwater line. The sheeting extends from ground surface to approximately 6 feet bgs (7.5 feet amsl) and is located along lower Unoco Road as shown on Figure 2-1 (ARCADIS 2009).

In 2008, 14 soil borings were installed along the south and southwest sides of the WSDOT stormwater line. Soil samples from five of these borings adjacent to the WSDOT stormwater line contained concentrations of COCs that exceeded Site RELs and/or CULs. The locations of these borings are to the south and southwest of the WSDOT stormwater line, at the end of upper and lower Unoco Road, and in the area between the WSDOT stormwater line and monitoring well MW-143. Soil samples containing COC concentrations exceeding Site CULs and/or RELs were collected between 4 and 8 feet bgs in this area, with TPH concentrations ranging from 3,720 to 16,900 mg/kg (ARCADIS 2010b).

In 2012, four monitoring wells were installed adjacent to the WSDOT stormwater line. Soil samples collected during the installation of two of the monitoring wells exceeded Site CULs and/or RELs at depths of 6 and 7 feet bgs, with concentrations of TPH ranging from 10,540 to 17,850 mg/kg. Soil samples collected from these wells at greater depths did not contain concentrations exceeding Site CULs and/or RELs, as discussed in Section 2.7.3. Both of these monitoring wells were installed in an area of known remaining soil impacts that were left in place during 2007/2008 excavation activities and verified during 2008 site investigation activities.

Eleven sample locations in two distinct areas adjacent to the WSDOT stormwater line (to the north and south/southwest) contain soil with concentrations of COCs greater than Site CULs and/or RELs. The depths of these remaining impacts occur between 4 and 8 feet bgs. The impacted soil is adjacent to the WSDOT stormwater line and

covers an area of approximately 0.31 acre, of the 22 total acres of the Lower Yard. The areas of limited remaining impacts are shown on Figures 4-1, 4-2, and 4-3.

4.2.1.2 Detention Basin No.2 Area

In 2011, soil investigation activities were conducted in the unexcavated areas surrounding DB-2, including the installation of 17 soil borings and eight piezometers. LNAPL was encountered in eight of the soil borings, located south of DB-2, along the northern-most 2007/2008 interim action excavation area, surrounding monitoring well MW-510, and in one location north of DB-2 and adjacent to the southwest corner of DB-1. LNAPL was encountered in these borings at depths from 7 to 12 feet bgs (ARCADIS 2012a).

Soil samples containing concentrations of COCs exceeding Site CULs and/or RELs were collected south of DB-2, along the northern-most 2007/2008 interim action excavation area, surrounding monitoring well MW-510, adjacent to the southwest corner of DB-1, on the berm separating DB-1 and DB-2, and in one location on the bank of Willow Creek at a depth of 0.5 to 1 foot bgs. Soil containing concentrations of COCs exceeding CULs and/or RELs was encountered in 11 of the 17 soil borings, at depths ranging from 4 to 14 feet bgs with concentrations ranging from 4,413 to 220,400 mg/kg. The area surrounding DB-2, where impacted soil was encountered, covers approximately 0.43 acre of the 22 total acres of the Lower Yard. Boring locations from the DB-2 investigation area are shown on Figure 2-14 and remaining soil impacts are shown on Figure 4-1.

4.2.1.3 Monitoring Well MW-129R, Southwest Lower Yard, and Southeast Lower Yard

Isolated soil samples from four locations which exceeded Site CULs and/or RELs for TPH and/or cPAHs are listed below and are shown on Figure 4-1. Per WAC-173-340-740 (7), we anticipate that post Interim Action work, statistical analysis of these samples will show they are not significant and further remediation will not be necessary. (MTCA compliance assessment requires the 95% upper confidence limit on the mean be less than or equal to the cleanup level, with less than 10% of the samples exceeding the cleanup level and no single sample exceeding twice the cleanup level):

- During the installation of monitoring well MW-129R, one soil sample collected at a depth of 7 feet bgs contained a concentration of TPH at 3,007 mg/kg.

- During Phase I of the 2007/2008 interim action, one soil sample collected from the southwest Lower Yard (sample EX-B18-VV-1-6SW) at a depth of 6 feet bgs had a TPH concentration of 4,980 mg/kg.
- During 2003 interim action activities, one soil sample collected from the southwest Lower Yard (sample SWLY-D-3 Wall-3.75) at a depth of 3.75 feet bgs had a TPH concentration of 2,923 mg/kg.
- During Phase II of the 2007/2008 interim action, one soil sample collected from the southeast Lower Yard (sample EX-B1-F-44-4) at a depth of 4 feet bgs had a cPAH concentration of 0.212 mg/kg.

4.2.1.4 Point Edwards Storm Drain

During the Point Edwards Storm Drain Line Excavation in 2003, two samples (STRM-6FLOOR-7 and STRM-4WALLE(2)-3) contained concentrations of COCs above applicable RELs/CULs (with TPH concentrations of 17,439 mg/kg and 15,388 mg/kg respectively, benzene concentration of 54.9 mg/kg for STRM-6FLOOR-7 and cPAHs TEQ concentration of 0.56 mg/kg for STRM-4WALLE(2)-3) and were not over-excavated in the 2007/2008 Excavation. These samples were collected at a depth of 7 feet bgs for the floor sample and at a depth of 3 feet bgs for the wall sample. Samples locations are shown on Figure 4-1. These samples are considered to be included within the WSDOT stormwater line area and will be addressed through the proposed interim action.

4.2.2 Groundwater

The CSM presented in the IAWP – Lower Yard (SLR 2007a) concluded that groundwater beneath the Site discharges to the surface water and sediment in Willow Creek. As a result, the IAWP – Lower Yard (SLR 2007a) established groundwater CULs based on the protection of surface water. Data collected from the interior and perimeter (property boundary) monitoring well locations are used to assess compliance.

4.2.2.1 Groundwater Concentration Trends

As of September 2014, 23 perimeter groundwater monitoring wells are sampled quarterly and 29 interior monitoring wells are sampled semiannually. Two perimeter wells (MW-529 and MW-530) and 10 interior monitoring wells (MW-126, MW-13U, MW-134X, MW-203, MW-525 through MW-528, MW-531, and MW-532) have only been sampled since the June 2012. The most recent groundwater monitoring event

that included all perimeter and interior wells took place in June 2014. Monitoring wells MW-510, MW-525, and MW-526 were the only wells that contained concentrations of dissolved petroleum hydrocarbon constituents that exceeded CULs, with TPH concentrations of 875, 8,014, and 964 µg/L, respectively. June 2014 groundwater sampling analytical results are presented on Figure 3-3.

TPH is calculated by summing the concentrations of GRO, DRO, and HO; where concentrations do not exceed method reporting limits, one-half of the reporting limit is used to calculate TPH. The CUL for TPH in groundwater is calculated based on the relative proportions of GRO, DRO, and HO, and thus differs at each monitoring location and with each monitoring event, as described in Section 5.3.2.

Dissolved concentrations of COCs in groundwater at the perimeter monitoring wells are summarized below:

- Since monitoring began in October 2008, six perimeter monitoring wells (MW-8R, MW-101, MW-108, MW-109, MW-523, and MW-524) have not contained concentrations of TPH greater than sample-specific CULs.
- Perimeter monitoring wells MW-529 and MW-530, located on the bank of Willow Creek have not contained TPH concentrations greater than laboratory detection limits since their installation in July 2012.
- From October 2009 to September 2012, monitoring well MW-510 was sampled once (June 2011) and contained a TPH concentration of 15,300 µg/L. It was not sampled during other monitoring events within this time period due to the presence of LNAPL. Samples were collected from MW-510 from December 2012 to June 2014, with a maximum TPH concentration of 6,140 µg/L (March 2014).
- Benzene has not been detected at concentrations greater than the Site-specific CUL of 16 µg/L in samples collected from any perimeter wells since 2009 (MW-20R and MW-510 with respective concentrations of 55 µg/L and 18 µg/L).
- cPAHs have not been detected at concentrations greater than the Site-specific CUL of 0.05 µg/L in samples collected from any perimeter wells since December 2012 (MW-510 with a concentration of 0.078 µg/L). cPAHs analysis conducted on samples collected from MW-104, MW-109, MW-135 exceeded the Site-specific CUL of TEQ of 0.05 µg/L because of the laboratory detection limit being greater than the CUL in the sampling events of 2011, 2011 and 2009 respectively.

Dissolved concentrations of COC in groundwater at the 29 interior monitoring wells are summarized below:

- Concentrations of TPH have not exceeded the sample-specific CUL in any interior monitoring wells (except MW-525 and MW-526) since June 2011 (MW-143 with a concentration of 1,745 µg/L).
- Fifteen of the 29 interior monitoring wells have never exceeded the sample-specific TPH CUL since the beginning of the monitoring period in October 2008.
- Monitoring well MW-525 has contained TPH concentrations exceeding the sample-specific CUL in all sampling events since its installation in June 2012, with a maximum concentration of 23,416 µg/L in December 2012. A sheen on water from this well has been observed during sampling events.
- Monitoring well MW-526 has contained TPH concentrations exceeding the sample-specific CUL for 4 out of 5 sampling events from December 2012 to June 2014 since its installation and initial sampling in June 2012, with a maximum concentration of 1,216 µg/L in June 2013.
- Since the beginning of the monitoring period in October 2008, benzene has been detected in only one interior monitoring well (MW-525), with a maximum concentration of 5,900 µg/L in December 2012.
- cPAHs have been detected at concentrations greater than the Site-specific CUL of TEQ of 0.05 µg/L in samples collected in only four interior monitoring wells since the beginning of the monitoring period in October 2008 except MW-502, MW-516, MW-519, and MW-526. cPAHs analysis conducted on samples collected from MW-502, MW-516 and MW-519 exceeded the Site-specific CUL of TEQ of 0.05 µg/L because of the laboratory detection limit being greater than the CUL in the sampling events of October 2010, April 2009, and August 2009 respectively. Monitoring well MW-526 has contained cPAHs concentrations exceeding Site-specific CUL of TEQ of 0.05 µg/L in 1 out of 5 sampling events from December 2012 to June 2014.

4.2.2.2 *Light Nonaqueous Phase Liquid.*

LNAPL has been effectively delineated and as of September 2014 is present at three locations in the DB-2 area in the Lower Yard. Piezometers P-12, P-13, and P-15 contain measurable thicknesses (>0.01 foot) of LNAPL, and are located within 100 feet of one another. From October 2009 to September 2012, LNAPL was present in

measurable thicknesses in well MW-510. LNAPL has not been detected in MW-510 in measurable thicknesses from December 2012 to the present (absorbent socks placed and changed every quarter).

LNAPL was present in piezometer P-12 in September 2011, June and September 2012, and June and September 2013. LNAPL has been present in piezometer P-13 since September 2011, and was present in piezometer P-15 in March and June 2013. Piezometers P-12, P-13, and P-15 were installed in August 2011.

LNAPL in piezometers P-12, P-13, and P-15 is black in color, has a high viscosity, and is difficult to recover with a bailer. During each monitoring event, an oil/water interface probe is used to measure depth to LNAPL and depth to water. Bailers are used to confirm the presence of LNAPL after each groundwater measurement in piezometers P-12, P-13, and P-15. Absorbent socks have been installed in monitoring wells MW-129R, MW-510, and MW-525 and are changed every quarter. Evidence of LNAPL is often observed on the absorbent socks recovered from MW-510 but rarely on the socks recovered from the other two wells.

4.3 Fate and Transport of Contaminants

Petroleum hydrocarbons within the unsaturated vadose zone and smear zone soils can exist in four phases: residual -phase (LNAPL is sorbed to soil or trapped within soil pore space), dissolved or aqueous-phase (LNAPL has dissolved in water within soil pore space), vapor-phase (LNAPL has volatilized into soil pore space), and free-phase (recoverable LNAPL). Following a release, the petroleum hydrocarbons are driven by gravity towards the water table and, depending on the quantity released, soil type, and depth to groundwater, may reach the groundwater table. As the hydrocarbons migrate towards the water table, some residual LNAPL is left behind in each of the phases.

When residual-phase, dissolved-phase or mobile LNAPL comes into contact with groundwater, dissolution of the hydrocarbons to the groundwater will occur. If a release of petroleum hydrocarbons is large enough, LNAPL will overcome the capillary forces at the capillary fringe within smear zone soils and pool on top of the groundwater.

When rainwater infiltrates subsurface soils in the area of a release, the water will flow downward through the soils and may preferentially follow high conductivity soil lenses horizontally before reaching groundwater.

LNAPL then dissolves into groundwater, sorbs to saturated soils, or remains above the displaced capillary fringe as LNAPL. LNAPL can then migrate along the groundwater flow path above the capillary fringe, while the dissolved-phase hydrocarbons follow the

groundwater flow path. Groundwater beneath the southeastern, eastern, and northwestern portions of the Lower Yard flows toward Willow Creek; groundwater beneath the southwestern Lower Yard flows toward Puget Sound; and groundwater beneath the central and north-central areas flows toward DB-1.

4.4 Potential Receptors

Potential human and ecological receptors are described below.

4.4.1 Human Receptors

The Lower Yard is currently vacant; therefore, current human receptors are limited to trespassers, environmental consultants, and subcontractors. Potential future receptors include construction workers exposed during redevelopment activities, as well as potential residents, commercial workers, and the general public if the Site is redeveloped as a ferry terminal as currently planned.

4.4.2 Ecological Receptors

The Lower Yard was a former industrial site that has been recently subject to intensive remedial activity, including excavation, backfilling, and grading. Following these activities, limited vegetation was present on the Site, but in recent years native and invasive vegetation has grown on the Lower Yard. Because petroleum hydrocarbons are not expected to enter the aquatic food chain, ingestion of fish or other aquatic biota (e.g., crayfish) is not considered a complete exposure pathway.

4.5 Potential Exposures

Potential exposures are possible for human and ecological receptors.

4.5.1 Exposures to Human Receptors

Current and future exposure scenarios exist for human receptors.

4.5.1.1 Current Exposures

Current human receptors at the Lower Yard are limited to trespassers and on-site environmental consultants, and their escorted visitors. These visitors include subcontractors, Chevron personnel, Ecology staff, and representatives from interested citizen groups. Current human receptors may be exposed to soil via incidental ingestion, dermal contact, and inhalation of windblown dust. They may be exposed to

surface water via direct contact or from eating contaminated seafood. There is no exposure to groundwater and exposure to soil vapor is minimal based on the current use of the Site. These exposures are discussed further in the following paragraph.

The Site-specific CULs and RELs established in the IAWP – Lower Yard (SLR 2007a) are based on standard Method B CULs for direct contact. The Method B CULs for direct contact are designed to protect children and assume a 16 kg average body weight and ingestion of an average of 200 mg/day of soil for six years. Because children are more highly exposed on a body weight basis than adults, the soil CULs and RELs are adequately protective of adult on-site environmental consultants and subcontractors. Inhalation of windblown dust is not explicitly addressed by the Method B CULs; however, the CULs are sufficiently protective of the inhalation pathway because soil exceedances are below ground and surface soil has been covered with clean backfill material. Therefore windblown dust is considered a limited exposure pathway for the COCs.

Currently, public access to Willow Creek is not allowed and exposure to the public is limited to trespassers. Exposure to the public would be very unlikely due to the restricted access to Willow Creek and even in contact with surface water in Willow Creek, potential exposure is expected to be insignificant because of no exceedance of surface water standards. The Method B surface-water CULs established for the Site are designed to protect human receptors from eating contaminated seafood, which is considered a more significant exposure route than incidental contact. CPAHs are not considered for this scenario as cPAHs have not been detected at concentrations greater than the Site-specific CUL in any perimeter wells since December 2013. Because petroleum hydrocarbons are not expected to enter the aquatic food chain, ingestion of fish or other aquatic biota (e.g., crayfish) is not considered a complete exposure pathway. Environmental consultants and subcontractors currently working at the Site are further protected from exposures by personal protective equipment and limited duration of exposure. Groundwater beneath the Lower Yard has been determined to be nonpotable groundwater (ARCADIS 2013a, SLR 2007a). Therefore, ingestion is not a potential exposure route. Similarly, direct exposure to groundwater represents an incomplete exposure pathway, unless the groundwater directly discharges to surface water. Site groundwater may discharge to the surface water of Willow Creek; but depending on the net flow in this mixing zone, groundwater seeping into Willow Creek will be quickly mixed with other water in the creek, reducing the concentration in the discharging groundwater and therefore further decreasing the exposure. Also, the tidal nature of Willow Creek and stormwater inputs to the creek will result in significant exchange (i.e., mixing) between discharging groundwater, tidal water, and stormwater.

Exposure to soil vapor by inhalation represents an incomplete exposure pathway due to the dilution in outdoor air.

4.5.1.2 Potential Future Exposures

If the Lower Yard is redeveloped, future human receptors at the Lower Yard could include construction workers, public, commercial workers and residents. Future human receptors may be exposed to soil via incidental ingestion, dermal contact, and inhalation of windblown dust. They may be exposed to surface water via direct contact or from eating contaminated seafood. They may be exposed to soil vapor by inhalation in an indoor environment or while excavating or trenching. Exposure to groundwater is an incomplete pathway unless the groundwater directly discharges to surface water. Details of potential future exposures are discussed in the paragraphs below.

If the Lower Yard is redeveloped in the future, construction workers may be exposed to soil via incidental ingestion, dermal contact, and inhalation of dust for short periods while excavating, trenching, or conducting other construction activities near DB-2 and the WSDOT stormwater line. Future commercial workers and residents may be exposed to soil via incidental ingestion, dermal contact, and inhalation of dust while working in buildings on the Site. However, as stated above, the Site-specific CULs and RELs established in the IAWP – Lower Yard (SLR 2007a) are based on standard Method B CULs for direct contact. The Method B CULs for direct contact are designed to protect children and assume a 16 kg average body weight and ingestion of an average of 200 mg/day of soil for six years. Because children are more highly exposed on a body weight basis than adults, the soil CULs and RELs are adequately protective of adult construction workers. Also, if the Site is redeveloped, commercial workers and residents are not expected to be exposed to surface and subsurface soil because the surface will be covered by buildings and pavement. Inhalation of windblown dust is not explicitly addressed by the Method B CULs; however, the CULs are sufficiently protective of that pathway because windblown dust is considered a limited exposure pathway for the COCs.

If human receptors use Willow Creek recreationally in the future, they could come into direct contact with surface water, and they could eat fish or shellfish. As stated above, Method B surface-water CULs are designed to protect people from eating fish or shellfish. Even in contact with surface water in Willow Creek, potential exposure is expected to be insignificant because of no exceedance of surface water standards.

Direct exposure to groundwater represents an incomplete exposure pathway, unless the groundwater directly discharges to surface water. Site groundwater may discharge to the surface water of Willow Creek; but depending on the net flow in this mixing zone,

groundwater seeping into Willow Creek will be quickly mixed with other water in the creek, reducing the concentration in the discharging groundwater and therefore further decreasing the exposure. Also, the tidal nature of Willow Creek and stormwater inputs to the creek will result in significant exchange (i.e., mixing) between discharging groundwater, tidal water, and stormwater. Due to the Lower Yard's proximity to Puget Sound, groundwater at the Site contains salinity levels that make it unsuitable for ingestion or for use as a potable water source. Therefore, groundwater ingestion is not a potential exposure route.

If the Lower Yard is redeveloped in the future, future construction workers may be exposed to soil vapor by inhalation while excavating, trenching, or conducting other construction activities near DB-2 and the WSDOT stormwater line. Future commercial workers and residents may be exposed to soil vapor by inhalation in constructions built above DB-2 and the WSDOT stormwater line. Exposure to soil vapor by inhalation while outdoor represents an incomplete exposure pathway due to the dilution in outdoor air.

An exposure pathways diagram is provided on Figure 4-4. Soil RELs and CULs that have been used to date are believed to be protective for current and future exposure scenarios (ARCADIS 2013c).

4.5.2 Exposures to Ecological Receptors

Ecological receptors at the Site and in the surrounding environment can be directly or indirectly exposed to remaining impacts if a complete exposure pathway exists. They may be exposed to soil, groundwater, surface water and sediment.

Important features that must be considered when evaluating exposure pathway completeness include:

- Chemical concentrations in different media and their respective locations.
- Physical and chemical properties of the COCs.
- Locations of habitats and other environmentally sensitive areas.

As noted above, the remaining impacts at the Site are limited to subsurface soil in two discrete areas of the Site, with elevated concentrations present at greater depths. The standard point of compliance for TEE is 15 feet but according to WAC 173-340-7490 (4)(a), a conditional point of compliance may be set at the biologically active soil zone. This zone is assumed to extend to a depth of six feet. Due to the shallow level of the

groundwater at the site, this alternative depth is more appropriate for the Site. Because a limited number of soil exceedances exist at the Site at depths above 6 feet bgs, this pathway will be further evaluated.

At the site, direct exposure to groundwater represents an incomplete exposure pathway, unless the groundwater directly discharges to surface water. Site groundwater may discharge to the surface water of Willow Creek but depending on the net flow in this mixing zone, groundwater seeping into Willow Creek will be quickly mixed with other water in the creek, reducing the concentration in the discharging groundwater and therefore further decreasing the exposure. This pathway will be further evaluated via the surface water pathway.

Aquatic receptors such as fish and water column invertebrates may be directly exposed to surface water via ingestion and direct contact/uptake. Method B surface-water CULs are protective of aquatic receptors living in Willow Creek and direct contact with surface water by upper-trophic-level wildlife through ingestion is not likely to occur given the brackish nature of the stream. Also, the tidal nature of Willow Creek and stormwater inputs to the creek will result in significant exchange (i.e., mixing) between discharging groundwater, tidal water, and stormwater.

As discussed in Section 3.6, sediment analytical results from Willow Creek indicate that sediment in Willow Creek does not contain contaminants in excess of the SMS SQS (Chapter 173-204 WAC), and most perimeter wells directly adjacent to Willow Creek currently comply with surface-water CULs.

Exposure to surface water and soil are considered the only potentially complete pathways for ecological receptors.

An exposure pathways diagram is provided on Figure 4-4. Soil RELs and CULs that have been used to date are believed to be protective for current and future exposure scenarios (ARCADIS 2013c).

5. Cleanup Standards³

A cleanup standard consists of the following three elements [WAC 173-340-700(3)]:

1. CUL, the concentration that must be met to protect human health and the environment.
2. POC, the location where the CUL must be achieved.
3. Other regulatory requirements commonly referred to as applicable or relevant and appropriate requirements (ARARs) that apply to a site because of the type of action or the location of the site (Appendix D).

The cleanup standards developed for and used during former interim action work are documented in the IAWP – Lower Yard (SLR 2007a), which is provided as Exhibit B to AO 4460. The cleanup standards were reevaluated in 2013 and are documented in the Cleanup Levels and Remediation Levels Report (ARCADIS 2013c). The National Recommended Water Quality Criteria (NRWQC) for marine organisms and humans ingesting organisms were updated in 2015 and therefore CULs developed in the Cleanup Levels and Remediation Levels Report (ARCADIS 2013c) were reevaluated accordingly. The cleanup standards were developed using a MTCA Method B approach and include the use of RELs as part of the interim action soil removal. This section discusses IHSs, and sediment, surface water, groundwater, and soil cleanup standards.

5.1 Indicator Hazardous Substances

IHSs are the chemicals that are expected to account for most of the risks at a site, and cleanup standards must be developed for each IHS in each medium. Cleanup of IHSs is expected to result in cleanup of chemicals that pose the balance of the risks. The IHSs for sediment, surface water, groundwater, and soil were developed in accordance with WAC 173-340-703, as documented in the IAWP – Lower Yard (SLR 2007a).

³ It is understood by Ecology and the PLP that the cleanup standards discussed in this IAWP are preliminary, and will be applied to this interim action until Ecology makes a determination on the applicable final cleanup standards in the Cleanup Action Plan for the Site.

The IAWP – Lower Yard (SLR 2007a) identifies four IHSs in the Lower Yard based on the history and previous investigations conducted at the Site. The following IHSs for soil were developed based on direct contact and leaching pathways: TPH (the sum of GRO, DRO, and HO); benzene; cPAHs adjusted for toxicity; and arsenic (direct contact only).

Groundwater IHSs were developed to protect surface water and sediment in Willow Creek. Arsenic was eliminated as a groundwater/surface-water IHS because arsenic concentrations in groundwater were determined to be caused by geochemical conditions associated with naturally occurring organic carbon sources in the soil beneath the Lower Yard, and arsenic concentrations in surface-water samples collected in Willow Creek reflect background concentrations (SLR 2007a).

5.1.1 Sediment

Sediment chemistry data were compared with SMS (Chapter 173-204 WAC) to identify IHSs for sediment. Prior to the 2007/2008 interim action, only total PCBs were known to be present at a concentration greater than the SMS. This PCB concentration was detected in one sample location (US-07), which was located near the terminal's stormwater outfall #002. Because of the presence of petroleum hydrocarbons in sediment and the possibility of a sediment-to-surface water pathway, several additional chemicals or compound groups were designated as tentative IHSs (TPH, PAHs, and metals) (SLR 2007a).

According to the SMS (Chapter 173-204 WAC), sites with sediment that exceed numeric chemical criteria may go through confirmatory biological testing. In 2003, biological testing of sediment samples was conducted at the Site to identify areas of sediment toxicity to help delineate the extent of sediment removal. Sediment samples were collected from 16 locations (US-01 through US-16) in all areas of Willow Creek. These samples were analyzed using a suite of chemical and bulk chemistry analyses. Due to elevated TPH concentrations, bioassay toxicity testing was conducted on sediment samples from six of the locations.

Results showed that the toxicity at two sample stations located near the Lower Yard outfalls into Willow Creek adjacent to the OWS and DB-2 (US-05 and US-07) exceeded CSLs. The sediment toxicity at the upstream (background) station adjacent to the southeast Lower Yard (US-15) prevented use of this station as a reference station for two of the three bioassay test species. Based on 2003 sediment sample data, IHSs were not identified for sediment and sediment CULs were not established for Willow Creek (SLR 2007a). The 2007/2008 interim action included the removal of

sediment that failed bioassay tests due to discharges at outfall locations made during facility operations (at Stations US-05 and US-07).

Three sediment samples were collected from Willow Creek on July 30, 2012 to assess sediment toxicity conditions near the 2003 sediment sampling location US-15, as described in the Final CSM (ARCADIS 2013a). Chemical analytical results for the sediment samples were evaluated to identify if bioassays should be performed on the samples. This determination was made by comparing the results to the SMS SQSs (Chapter 173-204 WAC) and CSLs. Based on an evaluation of the data, which showed that all results for the 2012 sediment samples were below the SMS SQS (Chapter 173-204 WAC) and the CSL or LAET, ARCADIS suggested that bioassay testing was not necessary. On August 9, 2012, Ecology concurred that bioassay testing was not needed and that no further cleanup of Willow Creek is required unless Willow Creek becomes contaminated by impacts remaining on site (ARCADIS 2013a).

5.1.2 Surface Water and Groundwater

Groundwater beneath the Site is considered nonpotable. AO 4460, Exhibit B, and Section 5.4.1 of this IAWP discuss this determination. The endpoint for groundwater is protection of Willow Creek (a tidally influenced stream) and Puget Sound.

The endpoint for groundwater CULs is protection of surface water; therefore, a combined list of groundwater and surface-water IHSs was developed (see AO 4460, Exhibit B, §5.1). TPH, benzene, chrysene, lead, zinc, arsenic, and copper were screened as potential IHSs. Concentrations of arsenic, copper, lead, and zinc in the surface water of Willow Creek were compared to screening levels to identify if the metals should be retained as surface-water IHSs. The samples collected in April 1996 and October 2003 did not contain dissolved copper, lead, and/or zinc concentrations above their screening levels. These results support the elimination of copper, lead, and zinc as surface-water IHSs.

The arsenic concentrations in all of the October 2003 samples were above the screening level; therefore, arsenic was retained for further analysis. Additional evaluation of the sampling results indicated that arsenic concentrations in the samples reflect the upstream concentrations that flow into the Site (background conditions), and that groundwater beneath the Lower Yard is not increasing the arsenic concentrations in the Willow Creek. On this basis, arsenic was eliminated as an IHS for surface water.

The final surface-water and groundwater IHSs are:

- TPH (sum of GRO, DRO, and HO concentrations)

- Benzene
- Toxicity-adjusted total cPAHs [sum of benzo(a)anthracene, benzo(a)pyrene, benzo(b)fluoranthene, benzo(k)fluoranthene, chrysene, dibenzo(a,h)anthracene, and indeno(1,2,3-cd)pyrene concentrations that are adjusted using toxicity equivalency factors to represent a total benzo(a)pyrene concentration]. (The toxicity equivalency factors published in WAC 173-340-900, Table 708-2 are used to make the adjustments).

5.1.3 Soil

The IAWP – Lower Yard (SLR 2007a) identifies IHSs for the following four endpoints considered for soil: terrestrial ecological evaluation (TEE), direct human contact (incidental ingestion), leaching to groundwater, and residual saturation.

For the TEE and residual saturation concentrations (C_{sat}), GRO, DRO, HO, benzene, cPAHs, and arsenic were considered potential IHSs. Because residual saturation is relevant only to organic chemicals that are in liquid form at ambient soil temperatures, arsenic was eliminated as an IHS for residual saturation. In addition, cPAHs, which exist as needles and platelets at ambient soil temperatures, were also eliminated as IHSs for residual saturation.

The final soil IHSs for the TEE and residual saturation are:

- TPH constituents (GRO, DRO, and HO)
- Benzene
- CPAHs (TEE only)
- Arsenic (TEE only)

For RELs and CULs based on direct human contact and to evaluate the leaching pathway, GRO, DRO, HO, benzene, and cPAHs were considered in combination to develop one Site REL for TPH. A separate soil CUL for benzene and a separate soil CUL for toxicity-adjusted total cPAHs were also developed to comply with the MTCA Method B risk target for individual carcinogens (1×10^{-6}) [WAC 173-340-705(2)(c)(ii)]. Arsenic was evaluated for direct contact, but not for leaching because arsenic is not an IHS for groundwater or surface water.

The final soil IHSs for direct contact and the leaching pathway are:

- TPH (sum of GRO, DRO, and HO concentrations)
- Benzene
- Toxicity-adjusted total cPAHs [sum of benzo(a)anthracene, benzo(a)pyrene, benzo(b)fluoranthene, benzo(k)fluoranthene, chrysene, dibenzo(a,h)anthracene, and indeno(1,2,3-cd)pyrene concentrations that are adjusted using toxicity equivalency factors to represent a total benzo(a)pyrene concentration]. (The toxicity equivalency factors published in WAC 173-340-900, Table 708-2 are used to make the adjustments.)
- Arsenic (direct contact only)

5.1.4 Surface-Water Screening for Metals

Concentrations of metals observed in the surface water of Willow Creek were compared against screening levels and background concentrations to identify if the metals should be retained as surface-water IHSs. Four metals (arsenic, copper, lead, and zinc) were reviewed. Copper, lead, and zinc were eliminated as IHSs based on comparisons to screening levels I) and arsenic was eliminated as an IHS based on comparisons to background concentrations (SLR 2007a).

5.2 Sediment Cleanup Standards

Sediment cleanup was based on bioassay data, as discussed in Section 3.5. Following the 2007/2008 interim action, Ecology concurred that cleanup of Willow Creek is complete (ARCADIS 2013a), as discussed in Section 3.5.

5.3 Surface-Water Cleanup Standards

5.3.1 Endpoints for Cleanup Levels

Method B surface-water CULs are endpoints for surface water and groundwater at the Lower Yard [WAC 173-340-730(3)(b)], as presented below:

- Washington State Water Quality Standards (WQSs) (Chapter 173-201A WAC) for marine water.
- NRWQC for marine organisms and humans ingesting organisms. The NRWQC for marine organisms and humans ingesting organisms were updated in 2015 and

therefore CULs developed in the Cleanup Levels and Remediation Levels Report (ARCADIS 2013c) were reevaluated accordingly.

- National Toxics Rule (NTR) related to human health [40 CFR 131.36(c)(14)].
- For hazardous substances for which sufficiently protective, health-based criteria or standards have not been established under applicable state and federal standards, MTCA Method B equation values are used for surface water.

Willow Creek is tidally influenced and is not a source of drinking water. The CULs applicable to the Site include the WQS and NRWQC based on use for aquatic organisms and human exposure based on ingestion of aquatic organisms (SLR 2007a, ARCADIS 2013a), the NTR, and MTCA Method B levels for TPH.

5.3.2 Cleanup Levels

The surface-water CULs are presented in Table 5-1 and represent the lowest of the WQS (WAC 173-201A-240), NRWQC, and NTR (40 CFR 131.36) and consider protection of fish and other aquatic life as well as protection of human health for consumption of organisms. The CUL has then been adjusted, as it may not be set at levels below the practical quantitation limit or natural background concentration, whichever is higher (WAC 173-340-730(5)(c)). The most stringent CULs for benzene and cPAHs are the NRWQC human health, considering human ingestion of marine organisms. The NRWQC for marine organisms and humans ingesting organisms were updated in 2015 and therefore CULs developed in the Cleanup Levels and Remediation Levels Report (ARCADIS 2013c) were reevaluated accordingly. The NRWQC human health (organisms only) for benzene (16 to 68 µg/L) is associated with a cancer risk of 2×10^{-6} , and the NRWQC for cPAHs (0.00013 µg/L) is associated with a cancer risk of 6×10^{-7} . Under the MTCA, standards are considered sufficiently protective if the cancer risk for those standards is less than 1×10^{-5} . The NRWQC for benzene and cPAHs is the most stringent CUL, however the practical quantitation limit for benzo(a)pyrene is 0.05 µg/L. Therefore an adjustment to the CUL for benzo(a)pyrene to the practical quantitation limit is required.

WQSs and NRWQC are not established for TPH mixtures. The MTCA allows the use of Method A groundwater CULs, whose beneficial use is drinking water, (WAC 173-340-900, Table 720-1) to calculate surface-water CULs for petroleum mixtures [WAC 173-340-730(3)(b)(iii)(C)]. This protects both marine life and human ingestion of marine organisms.

MTCA Method A CULs for TPH were derived by setting a hazard index (HI) of 1 for all three TPH constituents (DRO, GRO, and HO) and adjusting the compositions of each TPH constituent for each sample, on an individual basis. The CUL ranges from 500 to 800 µg/L, depending on the fraction composition of the sample. The CUL calculation is as follows:

Equation 1: TPH CUL = 1/(%GRO/800+%DRO/500+%HO/500)

Where:

- TPH CUL = Overall CUL adjusted for HI=1
- %GRO = Sample-specific percentage of GRO in groundwater, expressed as a decimal
- 800 = Method A groundwater CUL for GRO (µg/L)
- %DRO = Sample-specific percentage of DRO in groundwater, expressed as a decimal
- 500 = Method A groundwater CUL for DRO and HO (µg/L)
- %HO = Sample-specific percentage of HO in groundwater, expressed as a decimal

The surface water CULs are presented in Table 5-1.

Table 5-1. Surface-Water Cleanup Levels

IHS	Surface Water Cleanup Level (µg/L)
TPH	— ¹
Benzene ²	16
Total cPAHs ^{2,3}	0.05

Notes:

¹ Method A (WAC 173-340-900, Table 720-1); TPH calculated on a sample-specific basis. The CUL will fall between 500 and 800 µg/L, depending on the sample's composition.

² NRWQC for human-health (organisms only) (USEPA 2015). NRWQC. <https://www.epa.gov/wqc/national-recommended-water-quality-criteria-human-health-criteria-table> Accessed on June 6, 2016.

³ Total cPAHs adjusted for practical quantitation limit based on WAC 173-340-730(5)(c).

5.3.3 Surface-Water Points of Compliance

The POCs for surface water CULs are the point or points where hazardous substances are released to surface water [WAC 173-340-730(6)]. At the Site, hazardous substances are released to surface water from groundwater, thus the POCs for surface water CULs are those for groundwater CULs and are discussed in Section 5.4.3.

5.4 Groundwater Cleanup Standards

5.4.1 Endpoints for Cleanup Levels

Groundwater beneath the Lower Yard is considered nonpotable (ARCADIS 2013a, SLR 2007a). As such, the endpoint for CULs is based on a groundwater to surface-water interface. Groundwater beneath the Lower Yard is hydraulically connected to Puget Sound. The MTCA allows groundwater that is hydraulically connected to marine surface water to be classified as nonpotable if the following five criteria can be met [WAC 173-340-720(2)(d)]:

1. Groundwater does not serve as a current source of drinking water.
2. Ecology concurs that it is unlikely that the hazardous substances will be transported from the contaminated groundwater to groundwater that is or could be a source of drinking water.
3. There are known or projected points of entry of the groundwater into the surface water.
4. Surface water is not classified as a suitable domestic water supply source under Chapter 173-201A WAC.
5. Groundwater is sufficiently hydraulically connected to the surface water so that it is not practicable to use the groundwater as a drinking water source.

There are no drinking water supply wells located at the Lower Yard or between the Lower Yard and Puget Sound (SLR 2007a). As presented in the IAWP – Lower Yard (SLR 2007a), it is unlikely that the hazardous substances at the Lower Yard will be transported to an aquifer that could be used for drinking water (SLR 2007a).

Groundwater monitoring results demonstrate that the general direction of groundwater flow beneath the eastern part of the Lower Yard is toward Willow Creek, which discharges into Puget Sound, and the general direction of groundwater flow beneath the western part of the Lower Yard is toward Willow Creek and Puget Sound

(ARCADIS 2013a). Tidal response studies and salinity concentrations in groundwater have shown a hydraulic connection between groundwater beneath the Lower Yard and surface water in Willow Creek (directly connected to Puget Sound) (ARCADIS 2013a). Therefore, groundwater beneath the Lower Yard is hydraulically connected to Puget Sound (a marine water), which is not suitable for domestic water supply.

Based upon the above, the groundwater beneath the Lower Yard is nonpotable under WAC 173-340-720(2). The endpoint for groundwater is protection of surface water in Willow Creek and Puget Sound.

5.4.2 Cleanup Levels

The endpoint for groundwater is protection of surface water; therefore, the surface-water CULs presented in Section 5.3.2 establish the groundwater CULs for the Lower Yard.

5.4.3 Groundwater Point of Compliance

Based on Ecology’s direction in a letter dated May 21, 2014, the POC for groundwater is throughout the Lower Yard. Previously the interim POC for groundwater had been established at the perimeter of the Site where groundwater discharges to surface water, represented by 23 groundwater monitoring wells. Previous interim actions, consisting of excavation of impacted soil in various areas of the Site, have demonstrated that groundwater CULs can be met in a reasonable restoration timeframe in all areas, and groundwater monitoring wells throughout the Site should be used for compliance monitoring (Ecology, 2014a). POC for groundwater is monitored by 52 compliance monitoring wells - 23 monitoring wells located along the downgradient (western, northwestern, northeastern, and eastern) perimeter of the Lower Yard and 29 interior monitoring wells. The Lower Yard compliance monitoring wells are listed in Table 5-2.

Table 5-2 Groundwater Compliance Monitoring Wells

Perimeter Wells	Interior Wells
LM-2	MW-525
MW-101	MW-526
MW-104	MW-527
MW-108	MW-528
MW-109	MW-531
MW-129R	MW-532
MW-135	MW-502
MW-136	MW-503

MW-139R	MW-504
MW-147	MW-505
MW-149R	MW-506
MW-150	MW-507
MW-20R	MW-508
MW-500	MW-509
MW-501	MW-511
MW-510	MW-512
MW-518	MW-513
MW-522	MW-514
MW-523	MW-515
MW-524	MW-516
MW-529	MW-517
MW-530	MW-519
MW-8R	MW-520
	MW-521
	MW-13U
	MW-134X
	MW-126
	MW-143
	MW-203

5.5 Soil Cleanup Standards

Method B soil CULs are endpoints for the Lower Yard [WAC 173-340-740(3)(b)]. Six possible endpoints must be considered for soil:

1. TEE
2. Direct human contact (incidental ingestion)
3. Leaching to groundwater
4. Residual saturation
5. Inhalation of soil vapors
6. Dermal contact with soil

Previous soil RELs for the direct contact/dermal contact and leaching to groundwater pathways were calculated using a prior version of Ecology’s Workbook to calculate CULs for a petroleum mixture (MTCATPH11). A revised version of Ecology’s Workbook for calculating CULs for a petroleum mixture (MTCATPH11.1) was released

in December 2007 (Ecology 2007), subsequent to the submittal of the IAWP – Lower Yard (SLR 2007a).

The calculation formulas used for the revised Workbook (MTCATPH11.1) are the same as those used in the previous Workbook (MTCATPH11). However, several changes were made to the table of physical and chemical properties and the toxicological information for several petroleum fractions and individual hazardous substances, which affect the calculation results (Ecology 2007).

Since the soil-to-groundwater-to-surface water pathway is being assessed by empirical demonstration, the direct contact pathway becomes the most stringent pathway. Soil CULs were established to be protective of groundwater and hence are protective of surface water in Willow Creek. CULs protective of the direct contact/dermal contact and leaching to groundwater pathways were recalculated using the revised Workbook (MTCATPH11.1 [Washington State Department of Ecology 2007]) and are presented in Section 5.5.2. The remaining endpoints are discussed below. The final soil CULs and RELs, and POCs for soil are summarized in Sections 5.5.2 and 5.5.3, respectively.

5.5.1 Terrestrial Ecological Evaluation for Soil

In 2007, SLR conducted a TEE in accordance with the MTCA (WAC 173-304-7490 to -7493) for the Lower Yard (SLR 2007b). The 2007 TEE is included as Appendix E. The TEE for the Site calculated ecological indicator concentrations of 5,000 mg/kg for GRO, 6,000 mg/kg for DRO, 12 mg/kg for cPAHs [benzo(a)pyrene used as surrogate], and 132 mg/kg for arsenic in unsaturated soil [WAC 173-340-7493(2)(a)(i)]. According to the TEE performed by SLR in 2007, institutional controls, in the form of deed restrictions, will be used to document that any soils exceeding the ecological indicator soil concentrations are capped, that the caps are maintained, and that if the covering are disturbed, contaminated soils are handled appropriately [WAC 173-340-7493(2)(a)(ii)]. The combination of remedial actions, planned development, and institutional controls will minimize wildlife exposure to site-related contaminants.

No table values exist for HO or benzene. These ecological-based concentrations are greater than or equal to the soil CULs used for the interim action, based on direct human contact with soil.

The TEE performed by SLR in 2007 was reviewed to identify if the information used in the evaluation required updating. This review consisted of comparing Site-specific data to the TEE exclusion criteria in WAC 173-340-7491(1) and evaluating the information used in the Site-specific TEE performed by SLR in 2007 under WAC 173-340-7491(2), including information obtained from the following sources:

- Edmonds Crossing Final EIS (CH2M HILL 2001).
- WDFW Priority Habitat and Species database.
- Washington State Department of Natural Resources' Natural Heritage Information System.

The information obtained from the sources listed above and the rationale used to establish the ecological indicator concentrations in the 2007 TEE were re-evaluated. The ecological indicator concentrations of 5,000 mg/kg for GRO, 6,000 mg/kg for DRO, 12 mg/kg for cPAHs [benzo(a)pyrene used as surrogate] are still relevant to the Site. However, the arsenic value of 132 mg/kg is for Arsenic V. The cleanup level for Arsenic III should be used, which is 7 mg/kg. This will default to 20 mg/kg, the background value.

The planned use for the Lower Yard is commercial. The Lower Yard qualifies for an exclusion from a terrestrial ecological evaluation so long as its future land use will cover the Lower Yard with physical barriers to prevent plants and wildlife from being exposed to contamination. An Environmental Covenant to maintain the barrier is required. The planned future use shall include a completion date that is acceptable to Ecology [WAC 173-340-7491(1)(b)].

5.5.2 Direct Human Contact Soil Pathway

Soil CULs for direct human contact were developed in accordance with MTCA Method B, WAC 173-340-740(3)(b)(iii), Equations 740-2 and 740-3, and Ecology's MTCASGL10 spreadsheet (for benzene, toxicity-adjusted total cPAHs [benzo(a)pyrene equivalents], and arsenic) (SLR 2007b) and Ecology's MTCATPH11.1 spreadsheet for petroleum mixtures. No changes were made to the default exposure assumptions in any of the equations. The option for inclusion of dermal contact was not considered for benzene, toxicity-adjusted cPAHs, or arsenic, as presented in Section 5.5.7. TPH CUL development did include consideration of dermal contact.

Based on the results of these calculations, the Lower Yard TPH CUL is 2,775 mg/kg. This CUL was calculated based on the median of the 14 fractionated samples collected during the 2003 assessment and interim action (SLR 2007b). CULs for the direct contact pathway for benzene and cPAHs are based on the MTCA Method B direct contact Equation 740-1 [WAC 173-340-740(3)(b)(iii)(B)]. The arsenic cleanup level is based on its natural background concentration [WAC 173-340-740-(5)(c) and Table 740-1, footnote b]. These CULs are 18 mg/kg for benzene, 0.14 mg/kg for toxicity-

adjusted total cPAHs, and 20 mg/kg for arsenic. The direct soil contact values are presented in Table 5-3.

Table 5-3. Soil Cleanup and Remediation Levels

IHS	Soil Cleanup Level (mg/kg)
TPH ¹	2,775
Benzene ¹	18
Total cPAHs ^{1,2}	0.14
Arsenic ³	20

Notes:

¹ Proposed soil CUL based on soil direct contact pathway and proposed soil REL based on soil leaching pathway (See 5.5.4).

²Total cPAHs adjusted for toxicity based on WAC 173-340-708(8).

³ Based on natural background concentrations [WAC 173-340-740(5)(c)].

5.5.3 Soil Points of Compliance

Soil IHS concentrations protective of direct contact and TEE for soil in the Lower Yard will be met within the standard soil POC, which is within 15 feet of the ground surface. Soil CULs are protective of the residual saturation pathway throughout the saturated and unsaturated zones.

5.5.4 Soil Leaching Pathway

To evaluate the leaching to groundwater pathway for TPH, the revised Workbook (MTCATPH11.1 [Ecology 2007]) uses the three and four-phase partitioning models described in WAC 173-340-747 to calculate a CUL protective of potable groundwater. However, because groundwater beneath the Site is considered nonpotable, a soil CUL protective of surface-water quality is applicable. The revised Workbook (MTCATPH11.1 [Ecology 2007]) includes a feature that will calculate a soil CUL that is protective of surface-water quality by entering a target TPH groundwater concentration.

Using the results of the 14 fractionated samples discussed in Section 5.5.2 and a target TPH groundwater concentration of 561.3 µg/L (this is the average surface-water CUL at the Site calculated with Equation 1 shown in Section 5.3.2 for each TPH concentration of groundwater sampled from October 2008 to June 2014), the revised Workbook (MTCATPH11.1 [Ecology 2007]) calculated a median value of 100% LNAPL. This indicates that the TPH soil CUL exceeds the theoretical maximum TPH that would be reached if all of the available air space in the porous medium is filled with petroleum product. When 100% LNAPL is calculated as the leaching pathway CUL, the

revised Workbook (MTCATPH11.1 [Ecology 2007]) states that “soil-to-groundwater is not a critical pathway.”

Therefore, to demonstrate compliance with WAC 173-340-740(3)(b)(iii)(A), an empirical demonstration will be used to show that soil concentrations will not cause an exceedance of groundwater CULs. As defined under WAC 173-340-747(9), the following conditions are required for the empirical demonstration:

- The measured groundwater concentration is less than or equal to the applicable groundwater CUL established under WAC 173-340-720.
- The measured soil concentration will not cause an exceedance of the applicable groundwater CUL established under WAC 173-340-720 at any time in the future. Specifically, it must be demonstrated that a sufficient amount of time has elapsed for migration of hazardous substances from soil into groundwater to occur and that the characteristics of the Site (e.g., depth to groundwater and infiltration) are representative of future Site conditions. This demonstration may also include a measurement or calculation of the attenuating capacity of soil between the source of the hazardous substance and the groundwater table using Site-specific data.

Compliance monitoring will assess whether the empirical demonstration has been successful. The Compliance Monitoring Plan (CMP) for the DPE System and the Long-term Groundwater Monitoring will establish soil and groundwater sampling requirements.

5.5.5 Soil Residual Saturation

When LNAPL such as petroleum hydrocarbons is released to soil, some of the liquid will dissolve in the soil pore water, some will adsorb to the soil particles, some will vaporize in the soil pore air, and some will be held by capillary force in liquid form LNAPL in the soil pore spaces. The threshold concentration at which LNAPL becomes continuous in the soil pore space is called the C_{sat} . At concentrations just below C_{sat} , LNAPL exists in small, isolated blebs. The concentration at which the isolated LNAPL blebs become connected to form streamers is called residual saturation. At concentrations below residual saturation, the isolated blebs are relatively immobile. At concentrations above residual saturation, the LNAPL streamers can migrate downward under the force of gravity and the LNAPL can reach groundwater if a sufficient volume is present.

The IAWP – Lower Yard (SLR 2007a) evaluates soil residual saturation, considering default residual C_{sat} values of 1,000 mg/kg for GRO and 2,000 mg/kg for DRO from

MTCA Table 747-5. Data for additional soil types (MTCA 2007) indicate that residual Csat values for silt to fine sand (the predominant soil type in the unsaturated zone) can range as high as 9,643 mg/kg for GRO and 22,857 mg/kg for DRO. Residual Csat values for fine to medium sand (the predominant soil type in the saturated zone) can range as high as 5,625 mg/kg for GRO and 13,333 mg/kg for DRO. The IAWP – Lower Yard (SLR 2007a) does not use residual saturation to establish soil RELs/CULs.

An empirical demonstration may be used to show that LNAPL in soil is not impacting groundwater, if the following three criteria can be met [WAC 173-340-747(10)(c)]:

1. LNAPL is not accumulating on or in groundwater.
2. Soil contamination has been present sufficiently long for LNAPL to reach groundwater.
3. Site conditions will not change in the future to promote LNAPL migration.

LNAPL is no longer present at the Site, except in the area of and perhaps beneath DB-2, where soil impacts remain above TPH soil RELs (i.e., adjacent to DB-2) based on an evaluation of remaining soil impacts and associated LNAPL. Because LNAPL is not present where the soil RELs were met, the soil RELs are considered protective of groundwater for the residual saturation pathway. Ongoing groundwater monitoring will continue to assess the presence or absence of LNAPL in the monitoring wells and piezometers. In developing this IAWP, the direct contact TPH concentration was assumed to be less than Csat.

5.5.6 Soil Vapor Pathway

WAC 173-340-740(3)(b)(iii)(C) identifies conditions that determine if an evaluation of the soil to vapor pathway is required. These conditions include:

- For GRO, whenever the TPH concentration is significantly higher than a concentration derived for protection of groundwater for drinking water beneficial use under WAC 173-340-747(6) using the default assumptions.
- For DRO, whenever the TPH concentration is greater than 10,000 mg/kg.
- For other VOCs, including petroleum components, whenever the concentration is significantly higher than a concentration derived for protection of groundwater for drinking water beneficial use under WAC 173-340-747(4).

DRO concentrations in Site soil have been detected above 10,000 mg/kg. Additionally, GRO and VOCs have been detected in Site soil at concentrations higher than concentrations derived for protection of groundwater for drinking water beneficial use, which (under the MTCA) requires further evaluation of the soil to vapor pathway.

WAC 173-340-740(3)(c)(iv)(B) lists the methods available under the MTCA to evaluate if soil CULs are protective of the indoor or ambient air. These methods include:

- Measuring Site-specific soil vapor concentrations and demonstrating that they do not exceed air CULs established in WAC 173-340-750.
- Measuring ambient air concentrations and/or indoor air vapor concentrations throughout buildings, using methods approved by Ecology, demonstrating that air does not exceed CULs established under WAC 173-340-750.
- Use of modeling methods approved by Ecology to demonstrate that the air cleanup standards established under WAC 173-340-750 will not be exceeded.
- Other methods approved by Ecology demonstrating that the air cleanup standards established under WAC 173-340-750 will not be exceeded.

As discussed in Section 3.2, soil vapor sampling was conducted in 2013 to evaluate worst-case scenario vapor intrusion and to support remedial strategy decisions at the Lower Yard. Based on the results of the 2013 soil vapor sampling, it was identified that the further evaluation of the soil vapor pathway is necessary. Additional soil vapor sampling is proposed as part of the Interim Action as described in Section 7.

5.5.7 Soil Dermal Contact Pathway

Dermal contact with the IHSs must be evaluated if changes have been made to MTCA Method B direct contact equations, WAC 173-340-740, Tables 740-1 and 740-2 [WAC 173-340-740(3)(c)(iii)]. No changes were made to the equation for calculating CULs for benzene, toxicity-adjusted cPAHs, or arsenic (Equation 740-2). The dermal contact pathway is included in the equation for calculation TPH direct contact cleanup levels, Equation 740-3.

5.6 Summary of Soil and Groundwater Cleanup Levels

Water and soil CULs are summarized in Tables 5-1 and 5-2. The soil CULs of 2,775 mg/kg for TPH, 18 mg/kg for benzene, and 0.14 mg/kg for total cPAHs are based on

direct contact. The soil CUL of 20 mg/kg for arsenic is based on the natural background concentration.

The groundwater CULs are based on protection of surface water, using a weighted average of the Method A groundwater CULs for GRO, DRO, and HO, and considering the composition of TPH in groundwater beneath the Lower Yard using Equation 1. The groundwater CULs (51 µg/L for benzene and 0.018 µg/L for total cPAHs) are based on the protection of surface water and consider the human consumption of aquatic animals. Arsenic is not an IHS for groundwater.

6. Proposed Interim Action

To address objectives under Agreed Order No. DE 4460, this IAWP proposes to:

- Conduct an additional soil vapor assessment.
- Implement Alternative 6, excavation of DB-2 and DPE at the WSDOT Stormwater Line area, as described in the 2014 Proposed Addendum to the Draft Feasibility Study Report (FS Addendum [ARCADIS 2014a]).

The soil vapor assessment will focus on collecting data from additional locations in the Lower Yard to assess whether soil vapor hazards exist in the selected areas of the Lower Yard that were not previously tested; the collected data will also be used to optimize the DPE design.

As described in the FS Addendum (ARCADIS 2014a), Remedial Alternative 6 consists of:

- Excavation of the DB-2 vicinity
- Installation of a soil and groundwater treatment system using DPE technology to address impacts remaining near the WSDOT stormwater line area.

Alternative 6 will meet the objectives of the current interim action described in Section 1.1 as follows:

- Excavating petroleum hydrocarbon-impacted soil in the Lower Yard (near DB-2) that contains petroleum hydrocarbon concentrations above the RELs or CULs based on direct contact.
- Perform in-situ remediation of soil in the WSDOT stormwater line area and the Point Edwards storm drain area.
- Create a groundwater containment zone near the WSDOT stormwater line, where petroleum hydrocarbon-impacted groundwater is extracted and treated.
- Obtain the data necessary to evaluate if the remaining soil concentrations will cause an exceedance in groundwater.
- Obtain the data necessary to calculate the restoration timeframes to meet groundwater cleanup levels for TPH, benzene, and cPAHs.

- Remove the recoverable LNAPL beneath the Lower Yard by excavating the area near DB-2, where floating product has been observed.

The remaining objectives under Agreed Order No. DE 4460 will be addressed through compliance monitoring (described in Section 11).

7. Additional Soil Vapor Assessment

As described in Section 2.7.4 and shown in Table 2-6, the three locations sampled during 2013 (VP-1, VP-2, and VP-3) exceeded applicable screening levels for several parameters. Based on these results, Ecology requested additional assessment of soil vapor. This assessment will be conducted as a part of the interim action. This section describes the rationale, locations, and methodology for the additional assessment.

7.1 Soil Vapor Probe Installation

In addition to the three vapor probes (VP-1, VP-2, and VP-3) installed in October 2013, ARCADIS proposes to install seven additional permanent single-level on-site soil vapor probes (VP-4 through VP-10). Specifically, five soil vapor probes will be installed at 5 feet bgs and two soil vapor probes will be installed at 3 feet bgs. The sample locations and depths are proposed to further assess the potential for soil vapor at the Site. Soil vapor probe installation, sampling, and data evaluation will be completed in accordance with the VI Guidance (Ecology 2009). As noted previously, vapor probe locations VP-1, VP-2, and VP-3 were selected as worst-case scenarios for VOCs (specifically, GRO) and are located near locations with maximum GRO detections of limited extent (unexcavated areas).

Soil vapor probe VP-5 will be installed to evaluate soil vapor near the location of soil sample EX-B18-VV-1-6SW (TPH concentration of 4,980 mg/kg) in the southwest portion of the site, as requested by Ecology. Vapor probe locations VP-7 and VP-8 were selected to evaluate potential soil vapor in central locations of historical excavation activities, where both soil and groundwater concentrations are below applicable cleanup levels. These locations were selected to determine the potential influence of these known soil and groundwater concentrations on the vapor migration pathway under future receptor scenarios and the effectiveness of historical remediation activities with respect to the vapor intrusion pathway. Shallow soil vapor locations VP-4 and VP-6 were selected to evaluate the attenuation of potential subsurface soil vapor and further degradation of COCs as they migrate through clean soil at the surface of the site.

Soil vapor probes installed in October 2013 and the proposed installations included in this IAWP will be identified as shown in the following table.

Table 7-1. Soil Vapor Probes Identification

Soil Vapor Probe Identification	Installation Date	Installation Depth (feet bgs)	Location Description
VP-1	October 2013	5	Adjacent to monitoring well MW-525
VP-2	October 2013	5	Adjacent to monitoring well B-7
VP-3	October 2013	5	Adjacent to monitoring well MW-129R
VP-4	Proposed 2015	3	
VP-5	Proposed 2015	5	Adjacent to soil sample EX-B18-VV-1-6SW
VP-6	Proposed 2015	3	Central Lower Yard (fill)
VP-7	Proposed 2015	5	
VP-8	Proposed 2015	5	Southeast Lower Yard (fill)
VP-9	Proposed 2015	5	Southwest lower yard, northeast of and near MW-51
VP-10	Proposed 2015	5	Point Edwards storm drain, near the location of STRM-6FLOOR.

The soil vapor probe locations may be adjusted in the field based on accessibility, and with Ecology’s approval. Soil vapor probe locations are presented on Figure 7-1 and soil vapor probe schematics are presented on Figures 7-2 and 7-3.

The depth to groundwater at the Site is approximately 6 feet bgs. To collect soil vapor samples from vadose zone (above the groundwater table), each deep vapor probe (VP-5, VP-7, and VP-8) will contain one soil vapor probe set at 5 feet bgs or 1 foot above groundwater, whichever is encountered first. Shallow vapor probes (VP-4 and VP-6) will contain one soil vapor probe set at 3 feet bgs. Vapor probes will be installed and sampled in accordance with the Chevron ToolKit and ARCADIS Standard Operating Procedure listed in Appendix B.

The soil vapor samples will be shipped under appropriate chain of custody protocols to Eurofins Air Toxics Ltd. in Folsom, California, for the following analyses:

- Benzene and naphthalene by United States Environmental Protection Agency (USEPA) Modified Method TO-15 (low level).
- GRO (with specific carbon ranges: C5-C6 aliphatic hydrocarbons, >C6-C8 aliphatic hydrocarbons, >C8-C10 aliphatic hydrocarbons, >C10-C12 aliphatic

hydrocarbons, >C8-C10 aromatic hydrocarbons, and >C10-C12 aromatic hydrocarbons) by USEPA Method TO-15.

- Oxygen, carbon dioxide, methane, and helium by Modified ASTM International (ASTM) D-1946.

7.2 Data Evaluation

Measured concentrations will be reported in $\mu\text{g}/\text{m}^3$. Soil vapor data will be compared to Method B soil gas screening levels presented in Table B-1 of the VI Guidance (Ecology 2009). Soil vapor sample reporting limits will be established below the respective Method B shallow soil gas screening level. However, if dilution is required by the laboratory, reporting limits may be elevated.

7.3 Soil Vapor Data Screening Levels

The screening levels for soil vapor are listed in Table 7-2 below.

Table 7-2. Soil Vapor Data Screening Levels

Compounds of Concern	Laboratory Reported Compounds	Method B Shallow Soil Gas Screening Levels ($\mu\text{g}/\text{m}^3$)
Benzene	Benzene	3.2
Naphthalene	Naphthalene	14
Air-phase petroleum hydrocarbons (APH) aliphatic (C5-C8)	VPH aliphatic (C5-C6 + >C6-C8)	27,000
APH aliphatic (C9-C12)	VPH aliphatic (>C8-C10 + >C10-C12)	1,400
APH aromatic (C9-C10)	VPH aromatic (>C8-C10)	1,800

A comparison of VPH aliphatic carbon ranges >C8-C10 + >C10-C12 to the VI Guidance (Ecology 2009) APH aliphatic C9-C12, and the VPH aromatic >C8-C10 to the VI Guidance (Ecology 2009) APH aromatic C9-C10 is considered conservative due to potential petroleum hydrocarbons detected between >C8 and C9 carbon chains.

It is recognized that petroleum hydrocarbon vapors rapidly biodegrade in the soil column when sufficient oxygen is present. Aerobic biodegradation consumes oxygen and generates carbon dioxide. Comparison of fixed gas concentrations relative to

atmospheric levels will be discussed as a qualitative evaluation of the degree to which hydrocarbon vapors may be biodegrading at the Site.

8. Remedial Implementation

This section describes the implementation of Alternative 6 as described in the FS Addendum (ARCADIS 2014a). Alternative 6 includes excavation of the DB-2 vicinity and installation of a DPE system to address impacts remaining near the WSDOT stormwater line area.

8.1 Excavation of the Detention Basin 2 Vicinity

Excavation is an effective way to meet CULs because contaminants are physically removed from the Site. This technology has been used extensively in the Lower Yard in areas unencumbered by facility infrastructure. It has been both implementable and effective at removing impacted soil within these areas. Excavation has also reduced dissolved-phase petroleum hydrocarbon concentrations in groundwater to below CULs or within one order of magnitude of CULs across the site.

8.1.1 Description of Work

Excavation of the DB-2 vicinity will remove petroleum hydrocarbon-impacted soil above CULs, thus removing the direct contact exposure pathway. In addition to closing the direct contact exposure pathway, LNAPL will be removed from the excavation and disposed offsite. Dissolved-phase petroleum hydrocarbon impacts to groundwater will be remediated through extraction during excavation and through physical, chemical, and biological processes that, following source removal, will act to reduce the mass, toxicity, mobility, volume, and concentration of COCs.

8.1.2 Proposed Excavation Boundary

The proposed area of excavation was delineated during the 2011 soil assessment (ARCADIS 2011) and includes soil in the vicinity of MW-510. The proposed excavation will extend to approximately 10 to 12 feet bgs and the excavation boundary is limited by the following areas:

- To the northwest by the berm separating DB-2 from Willow Creek and extending approximately 200 feet to the southeast to the point where clean soil was observed during the 2011 soil assessment.

- To the northeast by the berm separating DB-1 and DB-2 and extending approximately 100 feet to the southwest to the edge of previous excavation work.

To safely remove petroleum hydrocarbon impacted soil in DB-2 and to allow adequate room to maintain excavation sidewall stability, a temporary earthen berm will be offset from the existing DB-1/DB-2 berm as shown on Figure 8-1. Water will be removed from the northwest portion of DB-1 and the proposed area of excavation. Soil above CULs in the DB-2 vicinity will be excavated.

As mentioned above, LNAPL will be removed from the excavation and disposed offsite. Water recovered from the excavation will be collected and stored in a holding tank. From the holding tank, water will be treated with an engineered treatment system that will include filter beds and activated carbon vessels, and then discharged to DB-1. The temporary water treatment system flow diagram is shown on Figure 8-2. A NPDES construction permit is required to discharge treated wastewater from excavation activities to DB-1 and will be obtained prior to excavation activities.

The berm separating DB-2 from Willow Creek will also be excavated. To protect Willow Creek, two coffer dams will be placed in Willow Creek approximately 200 feet apart along the northwest excavation boundary. Water from Willow Creek will be diverted around the coffer dams using pumps. Following excavation, the coffer dams will be removed and Willow Creek will be restored to its original stream bed.

Impacted soil in the area of DB-2 will be excavated and recoverable LNAPL will be removed using vacuum dewatering trucks. Waste material will be direct loaded into truck and trailers for offsite disposal, or stockpiled in a central location for loading into truck and trailers for transportation to an appropriate waste disposal facility. Following completion of the DB-2 excavation, the temporary berm will be removed and DB-1 will be returned to its original boundary. As part of site restoration, DB-2 will be removed from the Site. The proposed excavation boundaries, including the temporary berm location, are shown on Figure 8-1.

8.1.3 Confirmation Sampling – Soil

Confirmation samples will be collected from the base and sidewalls of the excavation on an approximately 25-foot grid to meet the performance monitoring requirements. The performance monitoring is described in Section 11. Samples will be submitted to a Washington State-approved laboratory for immediate analysis. Once analytical data indicate that applicable CULs are met throughout the area of excavation, the area will be backfilled with clean fill material. A detailed confirmation sampling plan is included in Appendix F.

8.1.4 Light Nonaqueous Phase Liquid and Groundwater Remediation through Excavation

It is anticipated that excavation of impacted soil and removal of recoverable LNAPL will mitigate the soil leaching to groundwater pathway. Previous excavation work at the Site has demonstrated that removal of impacted soil has resulted in a decrease in dissolved-phase concentrations downgradient and in the excavation area. Monitoring well MW-529, which is installed downgradient of the proposed excavation area, has demonstrated compliance with its respective groundwater CULs since its installation. Groundwater modeling data indicate that groundwater flux at perimeter well MW-510 stems from upgradient soil and groundwater conditions observed near DB-2. With source removal through excavation, and if dual-phase extraction in the WSDOT stormwater line vicinity is successful, dissolved-phase groundwater concentrations may meet applicable CULs upon completion throughout the Site. If dissolved-phase petroleum hydrocarbon concentrations remain above CULs after a six-year restoration time frame, dual-phase extraction may continue, a monitored natural attenuation (MNA) program may be implemented, or other cleanup actions may be undertaken, depending upon site conditions at the time.

As described below, wells and piezometers near the DB-2 excavation will be decommissioned during site preparation. Following the completion of excavation activities, three monitoring wells (MW-533 to MW-535) will be installed in the area of DB-2 as shown on Figure 8-1. These wells will be included in the groundwater CMP for the DPE System and the Long-term Groundwater Monitoring to assess whether applicable CULs are met. The performance and compliance sampling plan for the site is described in Section 11; associated details are included in the Sampling and Analysis Plan (SAP; Appendix F).

8.1.5 Site Preparation

Prior to excavation of DB-2, initial site preparations and protective measures will be taken, including:

- Development of an appropriate traffic control plan with decontamination procedures for equipment and workers at the Site.
- Stormwater management plan, including removal and reinstallation of existing stormwater conveyance piping that currently intersects the planned excavation area.
- Decommissioning of monitoring well MW-510, and piezometers P-10, P-11, P-12, P-14, P-15, and P-16.

- Relocation of the existing stormwater detention pump control system and associated buried electrical lines.
- Installation of coffer dams in Willow Creek.
- Construction of a temporary berm in DB-1.

A traffic control plan will include procedures detailing the proposed traffic flow pattern to minimize traffic-related incidents at the Site, minimize excavation down time, and verify that all vehicles traveling off the Site are adequately decontaminated. A truck wash will be installed so that vehicles entering the exclusion zone will undergo decontamination. Prior to leaving the Site, routine truck inspections will take place to verify loads are secured.

An air monitoring plan will be submitted before implementation of the IAWP. Adequate engineering controls will be implemented onsite to fulfill the requirements of the air monitoring plan.

Existing piping used to collect on-site stormwater intersects the excavation area and discharges into DB-2. Prior to excavation, the stormwater collection system will be rerouted around the proposed excavation area and discharge directly into DB-1 under the NPDES construction permit. Existing piping will be initially capped and then removed during excavation activities.

Existing monitoring wells and piezometers located in the excavation area will be decommissioned prior to excavation. Monitoring well MW-510 and piezometers P-10, P-11, P-12, P-14, P-15, and P-16 will be decommissioned according to the requirements of WAC 173-160-310.

The existing stormwater detention pond pumping system will be relocated to the berm northeast of DB-1. Pumps will be removed from DB-2 and existing pumps within DB-1 will be relocated to allow for installation of the temporary berm. Electrical lines will be removed from the DB-1/DB-2 berm and temporary aboveground wiring will control the pumping system in DB-1.

As discussed above, coffer dams and a temporary berm will be constructed in Willow Creek and DB-1, respectively. Installation of the coffer dams and temporary berm will allow for appropriate sloping of the excavation side walls to remove petroleum hydrocarbon impacted soil from the excavation area and along the excavation boundaries.

8.2 Dual-Phase Extraction for Washington State Department of Transportation Stormwater Line

A soil and groundwater treatment system using DPE will be installed to address impacts remaining near the WSDOT stormwater line area. DPE is a remedial technology that relies on mass transfer and subsequent extraction to reduce the mass of residual LNAPL in vadose and smear zone soils in the subsurface. Residual LNAPL is defined as LNAPL that is occluded by the aqueous phase, occurring as immobile ganglia surrounded by aqueous phase in the pore space or as immobile, non-water-entrapped LNAPL that does not drain from the pore spaces (White et al. 2004). Historical soil and groundwater concentrations and the historical occurrence of recoverable LNAPL observed prior to Lower Yard excavation activities are indicative of residual LNAPL.

Implementation of this strategy involves pilot testing (as described in Section 9), and installation and operation of a DPE system in the WSDOT stormwater line area. The DPE system will remediate soil impacts surrounding the WSDOT stormwater line and act as a groundwater extraction system, maintaining on-site control of dissolved-phase COCs and LNAPL. It is anticipated that reducing soil impacts to below soil RELs and CULs will result in groundwater meeting COC cleanup levels in the vicinity of the WSDOT stormwater line.

8.2.1 System Design

To develop a preliminary design and plan for field implementation, ARCADIS developed calculations based upon assumed implementation activities. The calculations assumed that DPE technology will:

- Lower the water table to approximately 11 feet bgs (6 feet potentiometric drawdown in the target treatment zone, thereby capturing and dewatering the residual LNAPL throughout a broad interval in the subsurface (i.e., smear zone).
- Introduce atmospheric air into soil pores in the residual LNAPL zone.
- Remove residual LNAPL through a combination of soil vapor extraction (SVE) and enhanced aerobic biodegradation.

Groundwater modeling of this technology demonstrates that drawdown rates required for effective DPE implementation are achievable and that DPE will contain groundwater in the area of remaining impacts (near the WSDOT stormwater line); therefore, groundwater with exceedances above cleanup levels will be prevented from leaving the

Lower Yard. The long-term, average groundwater extraction rate required to achieve 6 feet of potentiometric drawdown within the target treatment zone was estimated at 21 gallons per minute (gpm) using the MODFLOW model for the Site (ARCADIS 2014a). A description and additional information regarding the MODFLOW model is provided in the FS Addendum (ARCADIS 2014a). The location of DPE wells and the estimated radius of influence (ROI) for each are shown on Figures 8-3 and 8-4.

The preliminary design consists of an array of 13 groundwater extraction wells spaced approximately 60 feet apart, oriented along the alignment of the WSDOT stormwater line. Figure 8-3 shows a conceptual spacing of remediation wells. The water table in this area is encountered at approximately 5 feet bgs. Extraction wells are assumed to be 30 feet deep (screened from 5 to 25 feet bgs with 5-foot sump) and pump at a rate between 2 and 3 gpm each. A preliminary well layout is provided on Figure 8-3. Details for the extraction well design are provided in the FS Addendum (ARCADIS 2014a).

Data from the pilot test will be used to evaluate the effects of the WSDOT stormwater line and the polyethylene sheeting in the area of the DPE system. The effects of the polyethylene sheeting on groundwater extraction are not expected to be significant since groundwater extraction rates are based on site-wide hydrogeological conditions instead of conditions in close proximity to the WSDOT stormwater line, and the expected maximum water elevation during pumping will be below the stormwater line and bottom of the sheeting. Vapor extraction may be affected by the presence of stormwater line and sheeting; data collected from the pilot test will be used to determine if vacuum, vapor extraction rates or well locations would have to be modified accordingly.

Standard hydrogeological and environmental engineering calculations were used to predict remediation quantities such as groundwater extraction rates, groundwater elevations, chemical fluxes, and timeframes for remediation. Parameters used in the calculations were based on Site-specific measurements and standard literature values for constants. However, Site heterogeneity required that several parameters be estimated during calculations. To best manage the uncertainty in predicted quantities, a DPE pilot study (described in Section 9) will be performed in a portion of the target cleanup zone to collect field data needed to complete the final design.

8.2.2 System Install and Operation

Design of the DPE system will meet the requirements described in the Multi-Phase Extraction Standard Operating Procedure (Chevron 2006).

DPE systems typically use a network of remediation wells adequately spaced to dewater the target zone through the operation of pneumatic pumps. Groundwater is pumped to a remediation compound housing groundwater treatment equipment that may include an OWS, bag filters, particulate sand filters, an air stripper, and granular activated carbon (GAC) vessels prior to discharge to the existing storm sewer under a NPDES permit. Soil vapor is collected using a regenerative or positive displacement blower sized to induce vacuum from the remediation well on surrounding soil. The vapor stream passes through a condensation knockout tank before treatment by either a catalytic oxidizer or GAC and is vented to the ambient air under a Puget Sound Clean Air Agency (PSCAA) permit.

Each DPE well will be equipped with a pneumatic pump connected to an air supply line and groundwater discharge conveyance piping. The top of the well casing will be fitted with a connection to vapor extraction conveyance piping from the vacuum blower. Conveyance piping will be trenched below ground surface to a minimum depth of 18 inches or supported at ground surface where applicable and will connect to treatment equipment that will be housed in a newly constructed building located adjacent to the existing equipment shed in the southern area of the Lower Yard. The location of the equipment compound was selected based on the preliminary layout of the Edmonds Crossing Project and accepted by representatives from WSDOT during a site visit on October 14, 2014; however, the equipment shed can be relocated to accommodate the actual layout of the project. A preliminary system location in relation to the system layout is shown on Figure 8-4. Wells will be constructed of 4-inch Schedule 40 PVC with 0.02-inch wire wrapped screen from 5 to 25 feet bgs with a 5-foot sump, so total depth of each well will be 30 feet bgs. Below the well screen will be 5 feet of solid casing that will act as a silt collection sump to decrease the occurrence of pump fouling. Well construction details may change based on pilot test results and field observations during the time of drilling.

Extracted vapor and groundwater conveyance piping will connect to the system compound located in the southern portion of the Lower Yard, as shown on Figure 8-4. The system compound will consist of a system enclosure to house the groundwater and the extracted vapor treatment equipment. Extracted vapor will flow through a multiple leg manifold, with each leg consisting of an air flow meter, flow control valve, vacuum gauge, and sampling port. A main header will connect the manifold to an air/water separator prior to the blower. Vapor from the blower will discharge into a catalytic oxidizer for treatment prior to discharge to the atmosphere. Accumulated water from the separator will be transferred using a Moyno progressive cavity or similar pump, to the OWS that is part of the groundwater treatment equipment. A downhole pneumatic pump will lower the water table and transfer water to an OWS housed within the treatment compound.

Each wellhead will be fitted with a cycle counter, flow control valve, pressure regulator, and pressure gauge to quantify pumping volume and individual well pumping rates. Each groundwater pumping well will be completed with a well vault fitted with a mechanical float to shut off the well if pipe failure or leaks occur at the wellhead. Groundwater conveyance lines will be installed within secondary containment lines. A general DPE well connection detail is shown on Figure 8-5.

Groundwater will be pumped through the conveyance lines to the OWS, where baffles will remove any collected LNAPL. The OWS will be controlled with automatic float switches pumping water in batches through in-line particulate filters before being treated using an air stripper. Water will then be pumped to polishing treatment in liquid granular activate carbon (GAC) beds (two sets of two in series). Treated water will be discharged to Willow Creek or DB-1 under a NPDES permit. Based on pilot testing, the groundwater treatment component may change. A typical process and instrumentation diagram for these treatment trains is presented on Figure 8-6.

Power for the treatment building and equipment will be connected to the existing power service drop located between DB-1 and DB-2, near the north side of the Lower Yard. Electrical conduit will be placed in a trench as shown on Figure 8-4.

8.2.3 System Optimization and Operation

During startup activities, field operating conditions will be monitored and adjusted to verify design criteria are being met and are within permit requirements. Periodic site visits will be conducted to monitor and record readings from the DPE system. Initially, site visits may occur more than once a week, reducing to monthly visits following system optimization. Parameters such as pressure, flow, and temperature will be recorded and adjustments will be made to confirm the system is operating at optimal conditions and within permit limits. As required, maintenance will also be performed during Site visits. An operation and maintenance manual will be kept at the Site for reference and to verify proper operation of the system. Compliance monitoring will be conducted based on the appropriate permit requirements and schedule. Section 11 discusses compliance monitoring.

8.2.4 Applicable or Relevant and Appropriate Requirements

MTCA requires that all cleanup actions comply with applicable state and federal laws (WAC 173-340-710). MTCA defines applicable state and federal laws to include “legally applicable requirements” and “relevant and appropriate requirements.” Appendix D lists the permits or specific federal, state or local requirements that Ecology has identified are applicable and that are known at this time. Chevron has a continuing

obligation to review whether additional permits or approvals addressed in RCW 70.105D.090 (1) would otherwise be required for these interim actions. In the event that either Ecology or Chevron identifies that additional permits or approvals are needed, it shall promptly notify the other party.

The laws and regulations cited in Appendix D pertain to nonhazardous waste only because hazardous waste does not exist at the Site, and the generation, handling, and treatment/disposal of hazardous waste is not anticipated as part of the remedial action. Appendix D does not refer to State Dangerous Waste regulations (WAC 173-304) or Resource Conservation and Recovery Act Subtitle C regulations (40 CFR 260-268), which control the management and disposal of hazardous waste.

9. Pilot Testing⁴

The proposed DPE system described in Section 8.2 is based on standard hydrogeological and environmental engineering calculations. Parameters used in the calculations were based on site-specific measurements and standard literature values for constants. However, Site heterogeneity required that several parameters be estimated during calculations. To best manage the uncertainty in predicted quantities, a DPE and air sparge (AS) pilot study will be performed in a portion of the target cleanup zone to collect field data needed to complete the final system design.

The DPE portion of the pilot test will be used to calculate the achievable vapor exchange rate and to confirm pumping rates for the desired drawdown. The AS portion of the pilot test will evaluate the pressure and flow in the subsurface along with the effective sparging ROI. AS pilot test results will be used to design an AS system as part of the overall remedial strategy if DPE results do not meet remedial objectives.

9.1 Test Locations and Equipment

Two DPE wells (DPE-1 and DPE-2), one AS well, and two observation piezometer wells (PZ-1 and PZ-2) will be drilled by hollow stem auger and installed for pilot testing. DPE-2 will only be used as an observation well during pilot test activities. DPE-1 and DPE-2 will be advanced as 4-inch-diameter wells to 30 feet bgs, with 5 feet of solid casing at the bottom of the well to act as a collection sump, followed by 20 feet of screen and completed with 5 feet of solid riser. AS-1 will be installed as a 2-inch-diameter well to 18 feet bgs, with 3 feet of solid casing at the bottom of the well to act as a collection sump, followed by 2 feet of 0.020-inch slotted screen and completed with solid PVC riser. To facilitate the expansion of a full scale system, DPE-1 and DPE-2 will be installed at locations proposed for the full-scale DPE system. Well locations for this pilot test are identified on Figure 9-1. Cross sections of the DPE System area are presented on Figures 9-2 through 9-4. Figure 8-5 presents pilot test well details.

Piezometer wells PZ-1 and PZ-2 will be advanced as 2-inch-diameter wells to 25 feet bgs, with 20 feet of screen, to monitor the depth to water during pilot testing. Due to the location of the WSDOT stormwater line, piezometers will be installed north of DPE-1. The observation well and piezometers (DPE-2, PZ-1, and PZ-2, respectively) will be installed approximately 7, 15, and 30 feet away from DPE-1. AS-1 will be installed

⁴ Pilot testing activities at the Site have been conducted in February-March 2015 (prior to the publication of this Interim Action Work Plan as Final).

within 7 feet of DPE-1. Transducers will be installed in the piezometers and DPE well to log groundwater elevations during testing. These wells will also be equipped with gauges to monitor pressure during AS testing and vacuum during the vapor extraction testing portion of the pilot test.

The DPE and AS wells will be connected to a mobile trailer equipped with an air compressor and vapor extraction treatment system. The air compressor will be used for AS testing and to operate the pneumatic pump that will be inserted into DPE-1 for groundwater extraction. The pump will discharge into a temporary holding tank that will be mobilized to the Site for the pilot test. The vapor extraction system will consist of a rotary lobe positive displacement blower and moisture separator, prior to atmospheric discharge through the effluent stack.

9.2 Description of Work

For the DPE pilot test, step and constant rate tests will be performed for a maximum 72-hour period to test modeling assumptions and assist in final design of the full-scale DPE system. The DPE pilot test will consist of step and constant rate pumping and vapor extraction tests. Vacuum ROI, groundwater drawdown, and system operational pressures will be analyzed to identify if sufficient groundwater drawdown can be achieved to expose smear zone soil and to evaluate if effective mass removal is feasible. Mass removal will be quantified through flame ionization detector measurements, laboratory analysis of effluent concentrations, and flow rates.

An air sparge pilot test will be conducted if results from the DPE pilot test indicate a need for air sparging to supplement the remedial strategy. It will be performed to test the spargeability of subsurface soil. The AS test will evaluate the adequate pressure and flow rate required for a full-scale AS system. The AS pilot test will apply pressure and flow at increasing rates below the calculated soil fracture pressure.

9.2.1 Air Sparge Pilot Test

AS pilot test pressures are limited by the hydrostatic pressure (pressure required to displace water within the AS well) and the formation fracture pressure (overburden pressure plus the hydrostatic pressure). It is important not to exceed the formation fracture pressure because it can cause preferential pathways reducing the overall effectiveness of sparging. Based on subsurface medium- to fine-grained sands at the Site, the AS hydrostatic pressure is approximately 4 pounds per square inch (psi) and the formation fracture pressure is approximately 8.2 psi. Hydrostatic and formation fracture pressure calculations are included in Appendix G.

The air compressor will be attached aboveground to the AS well. Transducers will be installed in the surrounding monitoring wells, DPE well, and piezometers to track changes in groundwater elevation throughout the AS pilot test. Pressure gauges and headspace sampling ports will be fitted to the wellheads of the monitoring wells, DPE well, and piezometers to measure changes in the vadose zone pressure and the extent of phase transfer caused by sparging from dissolved phase into the vapor phase.

Pressure will be applied to the AS well until airflow is observed flowing to the well. Pressure will then be incrementally increased until 50% of the target flow rate of 10 standard cubic feet per minute (scfm) is achieved. Once pressure and flow have stabilized to steady-state conditions, the pressure will again be increased to achieve the target flow rate. If pressures approach 90% of the calculated formation fracture pressure of 8.2 psi before the target flow rate is reached, the pilot test will be stopped, and the well will be redeveloped and the pilot test will be conducted again. The objectives of the pilot test are as follows:

- Assess the vertical migration of the injected gas from the point of injection (top of AS well screen) up through the saturated zone and into the vadose zone.
- Test the wellhead pressure and air flow relationship to identify the design pressure and flow rate within the AS well.
- Calculate the size of the blower required for full-scale system operation.
- Identify the pulsed frequency and spacing of each AS well.

9.2.2 Pumping Tests

The initial step test will involve the incremental increase of extracted groundwater flow rates to measure the flow capacity of the extraction well, and the extraction flow rate needed to achieve the desired drawdown for full-scale design. Based on test modeling assumptions described in the FS Addendum (ARCADIS 2014a), a target extraction rate of approximately 2 to 3 gpm is estimated to achieve the desired drawdown (ARCADIS 2014a).

The step pump test will commence at 50% of the target flow rate. Groundwater elevation will be monitored using transducers in the pumping well and piezometers. Each step test will be conducted for approximately 30 minutes or until drawdown stabilizes. The step test will be repeated at 100 and 150% of the target flow rate. Flow rates used for testing may be adjusted based on field observation.

Data from the step test will be used to target the pumping rates for the vacuum-enhanced pumping test. At the conclusion of the pumping test, the groundwater extraction flow rate needed for the desired drawdown should be established; this flow rate will be used during the vapor extraction step and constant rate tests.

9.2.3 Vapor Extraction Tests

The step test for vapor extraction will be conducted at 50, 100, and 150% of the target vapor extraction vacuum of 6 inches of mercury (inHg). If induced vacuum is not observed in pilot test piezometers and monitoring wells, and vapor flow rates are less than 10 scfm, additional vacuum step tests will be conducted.

Each step of the vapor extraction step test will be conducted until stable readings are observed at vacuum monitoring points; the steps will continue for approximately 60 minutes. Readings will also be collected and recorded periodically from the vapor extraction treatment equipment including runtime, pre- and post-treatment flow rates, pre- and post-treatment VOC concentrations, and process temperatures. During the vapor extraction testing, transducers will continue to record the groundwater elevation in DPE-1 and monitoring piezometers.

The constant rate test will be conducted at the vapor extraction vacuum where the largest induced vacuum ROI is observed. The constant rate test will be performed for a maximum of 72 hours to identify longer term sustainability of the selected flow rate. Similar to the step test, readings will also be collected and recorded periodically from the vapor extraction treatment equipment and piezometers, monitoring wells, and DPE well. Data collected from the constant rate test will be used to specify petroleum hydrocarbon mass recovery rates. Laboratory analytical samples may be collected based on permitting requirements.

10. Other Potentially Applicable Requirements

The specific permits or consultations to be completed are listed below. All other potentially applicable requirements and permits required to maintain compliance with WAC 173-340-710 are described in Appendix D. The SEPA Environmental Checklist is provided in Appendix H.

Federal:

- Clean Water Act (CWA) Section 404 Permit
- Nationwide Permit (NWP) 38 Notification
- Rivers and Harbors Act Section 10 Permit
- National Environmental Policy Act (NEPA) Review

State:

- Hydraulic Project Approval
- State Environmental Policy Act (SEPA) Environmental Checklist
- NPDES Stormwater Permit
- Section 401 Water Quality Certification
- Coastal Zone Management Determination/Certification

Local (City of Edmonds):

- Shoreline Substantial Development Permit
- City of Edmonds Critical Area Determination
- Grading Permit
- Puget Sound Clean Air Agency (PSCAA) permit

The laws and regulations cited in Appendix D pertain to nonhazardous waste only because hazardous waste does not exist at the Site, and hazardous waste generation, handling, and treatment/disposal is not anticipated as part of remedial action. Appendix D does not refer to State Dangerous Waste regulations (WAC 173-304) or Resource Conservation and Recovery Act Subtitle C regulations (40 CFR 260-268), which control the management and disposal of hazardous waste.

11. Performance and Compliance Monitoring

Alternative 6 includes compliance monitoring as required by WAC 173-340-410 and 173-340-720 through 173-340-760. This section describes the components of compliance monitoring that will include protection, performance, and confirmation monitoring during and following excavation activities in the DB-2 vicinity and DPE operation to meet the following requirements:

- Protection monitoring will verify that human health and the environment are adequately protected during construction, operation, and maintenance periods.
- Performance monitoring will confirm that the cleanup action is performing in a manner that will allow for cleanup standards to be attained.
- Confirmation monitoring will verify the long-term effectiveness of the remediation efforts following completion of remedial activities.

General components of performance monitoring for DB-2 vicinity excavation activities and DPE operation conducting during IAWP are described below. Specific details are provided in the SAP presented in Appendix F.

General components of compliance monitoring for the long-term effectiveness of the remediation efforts following completion of remedial activities (confirmation monitoring) also are discussed below. Details will be provided in a separate Compliance Monitoring Plan (CMP) and an Operation and Maintenance Manual (OMM) for the DPE System.

11.1 DB-2 Excavation Activities Performance Monitoring

The performance monitoring associated with DB-2 excavation activities will consist of the following components:

- Excavated soil stockpile sampling to characterize the soil for disposal at a permitted landfill and for reuse.
- NPDES construction permit sampling of construction water discharged from the treatment system.
- Confirmation soil sampling from the bottom and sidewalls of the excavation to assess whether excavation has reached soil with COC concentrations less than RELs and CULs.

- Periodic groundwater monitoring of perimeter and interior wells to assess COC concentrations with respect to CULs.

11.1.1 Stockpile Characterization Sampling

Excavated soil from the DB-2 vicinity excavation will be temporarily stockpiled onsite for characterization sampling to determine appropriate disposal or treatment at the offsite waste facility. Characterization sampling will be conducted as required by the selected waste facility. Discrete soil samples will be collected and submitted for chemical analysis.

It is not anticipated that excavated soil from areas with remaining impacts will be reused onsite as backfill material. However, the west/southwest border of the DB-2 excavation is adjacent to 2007/2008 remedial excavation areas. In order to maintain slopes within the DB-2 excavation, a portion of the 2007/2008 backfill will need to be removed. The reuse of the backfill material from the 2007/2008 excavation activities is likely. The protocol used to confirm that soil is fit for reuse is provided in the SAP (Appendix F).

11.1.2 National Pollutant Discharge Elimination System Construction Permit

Prior to excavation, ARCADIS will submit an application to obtain a NPDES permit to discharge collected groundwater treated during excavation to DB-1 for subsequent discharge to Willow Creek. The NPDES construction permit is designed to verify human health and the environment are adequately protected during construction periods. A temporary groundwater/stormwater treatment system will be constructed to handle and treat petroleum-impacted groundwater and sediment-impacted stormwater during construction activities, as shown on Figure 8-2.

The proposed wastewater discharge under the NPDES construction permit will be characterized for the following parameters:

- BTEX
- GRO, DRO, and HO
- Lead and arsenic
- 1-Methylnaphthalene, 2-methylnaphthalene, and naphthalene
- pH, turbidity, and total suspended solids (TSS)
- PAHs

The actual list of required analytes and respective methodologies will be included in the NPDES construction permit at the time of issue.

11.1.3 DB-2 Vicinity Excavation Performance Sampling

To monitor the progress of excavation activities and confirm that applicable CULs have been met, soil samples will be collected from the sidewalls and base of the excavation. If laboratory analytical results exceed applicable RELs and CULs, excavation and sampling in the area will continue until final performance samples are below applicable soil CULs.

Performance sampling will be conducted on a 25-foot grid. Grab samples will be collected following procedures specified in the SAP (Appendix F). Samples from the excavation will be submitted to a Washington State Department of Ecology-approved laboratory for the following analyses:

- Benzene by USEPA Method 8021B
- GRO by Ecology Method NWTPH-Gx
- DRO and HO by Ecology Method NWTPH-Dx (after silica gel cleanup)
- PAHs by USEPA Method 8270C

11.2 Long term Groundwater Compliance Monitoring

Periodic groundwater monitoring of compliance wells will be conducted to measure long term COC trends following excavation activities to verify the long-term effectiveness of remediation efforts. Similar to the existing groundwater compliance monitoring, sampling events will be conducted quarterly and semiannually for interior and perimeter compliance wells. Compliance groundwater monitoring will continue at the Site until COC concentrations in Site wells meet CULs for a minimum of eight consecutive quarters. Details of the compliance groundwater monitoring activities will be covered in the CMP to be submitted under separate cover.

11.2.1 Monitoring Well Installation and borings

As discussed in Section 8.1.4, monitoring wells and piezometers in the DB-2 excavation vicinity will be decommissioned prior to excavation activities. Following the completion of excavation activities, three new monitoring wells (MW-533 to MW-535), installed as described in the SAP (Appendix F) and shown on Figure 8-1, will be

included in the groundwater compliance monitoring to confirm long-term effectiveness of excavation activities.

During well installation, soils will be classified using the Unified Soil Classification System (USCS). Field screening of soil samples will include the use of a PID as well as visual observations of potentially impacted soil, visual observations of the presence of LNAPL or sheen, and observations of odor. Since all wells will be installed within the DB-2 excavation backfill, it is not anticipated that samples will be collected for chemical analysis.

11.2.2 Groundwater Sample Collection and Analysis

Groundwater compliance monitoring will include gauging and sampling interior and perimeter compliance wells. Wells will be gauged to measure water levels, the presence of recoverable LNAPL, and to calculate hydraulic gradient across the Site.

Groundwater samples will be collected using low-flow methods to monitor dissolved-phase COC concentrations in compliance wells and to assess MNA parameters. During purging, water quality parameters (dissolved oxygen, oxidation-reduction potential, pH, conductivity, and temperature) will be monitored. Samples will be collected once parameters stabilize.

Analytes will include the following:

- Benzene by USEPA Method 8021B
- GRO by Ecology Method NWTPH-Gx
- DRO and HO by Ecology Method NWTPH-Dx (after silica gel cleanup)
- PAHs by USEPA Method 8270 SIM
- Sulfate and nitrate by USEPA Method 300.0
- Dissolved methane by USEPA Method RSK 175
- Dissolved manganese by USEPA Method 200.8 (field filtered)
- Ferrous iron (Hach field kit)

The sampling schedule and methodology will be described in a CMP to be submitted under separate cover.

11.3 Dual-Phase Extraction Compliance Monitoring

Compliance monitoring during and following DPE operation include the following components:

- DPE system monitoring (including NPDES monitoring of discharged water, PSCAA compliance monitoring of discharged air, and groundwater capture zone assessment).
- Periodic groundwater monitoring of compliance wells to assess COC concentrations with respect to CULs.
- Soil sampling in known areas of impact to assess compliance with RELs and CULs.

11.3.1 Dual-Phase Extraction System Monitoring

Routine operation, maintenance, and monitoring of the remediation system will be performed to verify that the requirements of performance monitoring per WAC 173-340-310 are met. As described in Section 8.2.3 System Optimization and Operation, periodic Site visits will be conducted to collect data and perform tasks that will be used to track remedial progress, verify operational compliance, and if necessary, to schedule maintenance and/or replacement work. System performance monitoring requirements and maintenance activities will be described in an Operations and Maintenance Manual (OMM) that will be prepared prior to system operation; the OMM will be updated periodically.

To assess whether that the DPE system is effectively capturing groundwater and mitigating offsite migration of impacted groundwater, quarterly groundwater gauging will be performed. Potentiometric surface maps will be created.

A PSCAA permit will be needed to discharge treated effluent air to the atmosphere and a NPDES permit to discharge treated groundwater to DB-1. ARCADIS will submit applications for PSCAA and NPDES permits prior to DPE implementation so that permits are issued prior to system operation.

Details will be provided under a separate cover in the OMM for the DPE System.

11.3.1.1 Puget Sound Clean Air Agency Compliance Monitoring

Post-treatment effluent air monitoring will occur monthly to maintain compliance with the requirements of the PSCAA permit. Extracted vapor from the DPE wells will flow through a condensation knockout tank before treatment by either a catalytic oxidizer or GAC and vented to ambient air. Air samples will be collected monthly from the post-treatment effluent stack and samples may be analyzed for the following compounds:

- Benzene by USEPA Method 18
- GRO by USEPA Method 25

The actual list of required analytes and respective methodologies will be included in the PSCAA permit at the time of issue. Details will be provided under a separate cover in the OMM for the DPE System.

11.3.1.2 National Pollutant Discharge Elimination System Compliance Monitoring

Post-treatment DPE effluent groundwater sampling will occur as required by the NPDES permit. Extracted groundwater will be pumped by the DPE system through an OWS, followed by a particulate filter, air stripper, and GAC beds. Treated water will be discharged to DB-1 under a NPDES industrial stormwater permit. The NPDES permit will be a revised version of the NPDES construction permit used during excavation activities conducted at the Site in 2007-2008. The proposed wastewater discharge will be characterized for the following parameters:

- BTEX
- GRO, DRO, and HO
- Lead and arsenic
- 1-Methylnaphthalene, 2-methylnaphthalene, and naphthalene
- pH, turbidity, and TSS
- PAHs

The actual list of required analytes and respective methodologies will be included in the NPDES permit at the time of issue. Samples will be collected using procedures described in the SAP (Appendix F).

11.3.2 Groundwater Compliance Monitoring

Groundwater monitoring will include gauging and sampling of perimeter and interior monitoring wells. Compliance wells will be gauged to monitor water levels, the presence of recoverable LNAPL, and to measure the hydraulic gradient across the site. Samples will be collected from the compliance wells to monitor dissolved-phase COC concentrations and to assess MNA. The sampling schedule and methodology will be described under a separate cover in CMP for the DPE System and the Long-term Groundwater Monitoring.

11.3.3 Washington State Department of Transportation Stormwater Line Soil Sampling

After the DPE system has operated for a period of time, soil sampling will be conducted in areas of known impact near the WSDOT stormwater line to assess whether applicable direct contact soil CULs have been met and to assess the long-term effectiveness of the remediation efforts. Sampling will be conducted when operational data indicate the system has treated vadose and smear zone soils, as evidenced by decreases in vapor phase concentrations in the effluent air stream or a decrease in concentrations of COCs in monitoring wells MW-525 and MW-532. The sampling schedule and methodology will be described under separate cover in a CMP for the DPE System and the Long-term Groundwater Monitoring.

12. Construction Documentation

A Professional Engineer, licensed in the state of Washington, or a technician under the direct supervision of a Professional Engineer licensed in the state of Washington, will provide oversight on all aspects of construction as required by WAC 173-340-400(6)(b).

Records will be kept to detail items installed and the tests and measurements performed. The contractor will record work performed during construction activities. Records will include construction techniques and the materials used. The contractor will also complete the following records:

- *Daily Activity Log.* This log will be completed daily and will document activities and personnel working at the Site. Daily Activity Logs will be provided weekly to the designated Chevron representative.
- *On-Site Transfer Log.* This log details soil generated and transferred within the Site boundaries (e.g., excavation area to stockpile area), as well as the approximate quantity and source of the soil (e.g., Excavation Area A).
- *Off-Site Tracking Log.* This log will be a continuous log of all off-site shipments. Detailed information contained in this log will include type and source of material, day shipped, receiver, and weight of the material. A copy of the Off-Site tracking log will be provided to designated Chevron representative weekly.
- *Health and Safety Log.* Health and safety monitoring results will be recorded daily on the Health and Safety Log. The information recorded will include the personnel working at or visiting the Site and the levels of personal protection used.

The following items will be completed by Chevron or a designated representative:

- *Bills of Lading for Shipment.* The contractor will provide Chevron with bill of lading information. It will be Chevron's responsibility to review and sign all bills of lading for waste shipment.
- *Compliance Monitoring Documentation.* All analytical data will be uploaded to Ecology's Electronic Information Management (EIM) database.

Upon completion of excavation activities, a registered surveyor will survey the boundary. As-built drawings will be generated for the Interim Action As-Built Report based on these surveys.

13. Reporting

Ecology will receive and approve construction specification documents prior to the beginning of construction activities.

An Interim Action As-Built Report will be completed by the engineer responsible for oversight of the interim action. In accordance with WAC 173-340-400(6)(b)(ii), the Interim Action As-Built Report will be prepared at the completion of construction, will document all aspects of facility construction, and will include as-built drawings. The report will also contain an opinion from the engineer, based on testing results and inspections, as to whether the cleanup action has been constructed in substantial compliance with the plans, specifications, and related documents.

The following information will be provided in the Interim Action As-Built Report:

- Field activity descriptions, to include any unusual or unexpected events or conditions.
- Excavation figures showing final vertical and lateral excavation extents.
- Post-excavation figures showing soil sampling locations and results.
- Summary, in tons or cubic yards, of soil transmitted off the Site, estimated volume of extracted recoverable product and groundwater.
- Summary, in gallons, of recovered product and groundwater transmitted off the Site.
- Summary, in gallons, of recovered groundwater that was treated and discharged to Willow Creek.
- Daily field documentation and reports.
- Copies of chain of custody forms and laboratory reports.
- Copies of bills of lading.
- Electronic database on CD containing sampling data. All sampling data will be submitted to Ecology's Environmental Information Management System as required by the AO.

- DPE pilot test results.
- Routine system operation and maintenance reports.
- Performance Monitoring Report.

A groundwater sampling report will be prepared after each year of sampling and will include the following:

- Descriptions of field activities, to include any unusual or unexpected events or conditions.
- Figures displaying TPH, benzene, and total cPAH concentrations in the groundwater samples.
- Tables containing groundwater monitoring data, as well as groundwater sample analytical results (geochemical indicators and IHSs).
- Copies of laboratory reports and chain of custody documentation.
- Electronic database containing all sampling data.

14. Public Participation

The 2007 Public Participation Plan, prepared cooperatively by Chevron and Ecology, defines the public involvement activities to be accomplished related to remedial actions at the Site. These required activities are relevant to the interim action.

The required public involvement activities will be led by Ecology, with informational support from Chevron. The activities will be based on the 2007 Public Participation Plan that was cooperatively prepared by Chevron and Ecology. These activities are relevant to the interim action and are summarized below:

- A 30-day public comment period will be established. During this time, this Interim Action Work Plan will be available for review.
- Notice will be placed in the MTCA Site Register.
- Fact sheet describing the interim action plan will be prepared and distributed by Ecology.
- Public comment period and public meeting information will be advertised in the local newspaper of highest circulation.

Chevron will prepare and distribute letters to neighbors adjacent to the Site. These letters will include Chevron contact information, describe interim action activities, and present a schedule. Chevron may distribute letters at various times to confirm that property owners are aware of imminent activities.

15. Schedule of Deliverables

The Schedule of Deliverables is provided in Table 15-1. Ecology will endeavor to return comments by the dates in the Schedule of Deliverables. If Ecology does not return comments by these dates, there will be a day-for-day extension of the schedule.

Under the IAWP, the DB-2 excavation will be conducted and a DPE system adjacent to the stormwater line will be installed. The DPE system will be operated in accordance with the OMM. After 12 months of operation, or upon obtaining asymptotic mass removal rates from the pretreatment effluent vapor stream, whichever comes earlier, an evaluation will be conducted to confirm the ability of the DPE system to achieve remediation objectives within the calculated restoration time frame. The evaluation will also assess whether the system's hydraulic capture zone is calculated and confirmed by field measurements to be at least as large as the zone described in the Engineering Design Report, and the evaluation will verify whether the discharge from the DPE system meets NPDES permit requirements. The CMP will establish the soil and groundwater sampling requirements that will be needed to confirm the remediation has met the calculated CULs throughout the Site.

Upon completion of the interim action (excavation of DB-2 and installation of the DPE system) and the DPE system evaluation described above, the FS Report for the Site will be finalized.

A draft Cleanup Action Plan will then be prepared and submitted to Ecology for review as required by Agreed Order No. DE 4460. If the Interim Action has resulted in soil and groundwater meeting cleanup standards, the draft Cleanup Action Plan will document that cleanup standards have been met. If soil and groundwater cleanup standards have not been met, the draft Cleanup Action Plan will develop alternative cleanup actions to achieve cleanup standards and may present a preferred cleanup action.

Ecology will review the draft Cleanup Action Plan and use it as the basis for preparing Ecology's draft Cleanup Action Plan. Ecology's draft Cleanup Action Plan will be an exhibit to a new draft Consent Decree. The new draft Consent Decree will be issued for public comment and revisions will be made as necessary. Upon entry into Snohomish County Superior Court, the new Consent Decree will take effect and govern further actions at the Site.

References

ARCADIS U.S., Inc. 2009. Phase I Remedial Implementation As-Built Report, Unocal Edmonds Bulk Fuel Terminal Lower Yard. July 31, 2009.

ARCADIS U.S., Inc. 2010a. Final Phase II Remedial Implementation As-Built Report, Unocal Edmonds Bulk Fuel Terminal Lower Yard. January 18, 2010.

ARCADIS U.S., Inc. 2010b. 2008 Additional Site Investigation and Groundwater Monitoring Report, Former Unocal Edmonds Bulk Fuel Terminal (Lower Yard). January 18, 2010.

ARCADIS U.S., Inc. 2012a. Final 2011 Site Investigation Completion Report, Former Unocal Edmonds Bulk Fuel Terminal, May 11, 2012.

ARCADIS U.S., Inc. 2012b. Final Feasibility Study Work Plan, Former Unocal Edmonds Bulk Fuel Terminal. October 5, 2012.

ARCADIS U.S., Inc. 2013a. Final Conceptual Site Model, Former Unocal Edmonds Bulk Fuel Terminal. June 7, 2013.

ARCADIS U.S., Inc. 2013b. Soil Vapor Investigation Work Plan. Former Unocal Edmonds Bulk Fuel Terminal. September 16, 2013.

ARCADIS U.S., Inc. 2013c. Cleanup Levels and Remediation Levels Report, Former Unocal Edmonds Bulk Fuel Terminal. September 17, 2013.

ARCADIS U.S., Inc. 2014a. Proposed Addendum to the Draft Feasibility Study Report, Former Unocal Edmonds Bulk Fuel Terminal, August 11, 2014.

ARCADIS U.S., Inc. 2014b. Errata Sheet - Revised 2011 Site Investigation Completion Report, Former Unocal Edmonds Bulk Fuel Terminal, November 20, 2014.

CH2M Hill. 2001. SR 104 Edmonds Crossing, Volume 1 – Preliminary Final Environmental Impact Statement and Preliminary Final Section 4(f) Evaluation. February 2001.

Chevron Environmental Management Company. 2006. Multi-Phase Extraction Standard Operating Procedure, August 9, 2006.

Chevron Environmental Management Company. 2012. In-Situ Air Sparging Guidance Document.

Devlin, J.F. 2003. A Spreadsheet Method of Estimating Best-Fit Hydraulic Gradients Using Head Data from Multiple Wells. Groundwater. Vol. 41. No. 3: 316-320.

EMCON. 1994. Background History Report UNOCAL Edmonds Bulk Fuel Terminal. February 15, 1994.

EMCON. 1995. Remedial Investigation Work Plan, Unocal Edmonds Bulk Fuel Terminal, April 26, 1995.

EMCON. 1998. Remedial Investigation Report, Unocal Edmonds Bulk Fuel Terminal. October 19, 1998.

EMCON. 1999. 1998 Interim Product Recovery Operations Report, Unocal Edmonds Bulk Fuel Terminal. February 25, 1999.

Landau Associates, Inc. 1998. Petroleum Hydrocarbon Investigations, South Marina, Port of Edmonds, Washington. April 8, 1998.

Landau Associates, Inc. 2004. Petroleum Hydrocarbon Investigations, South Marina Dry Stack Storage Facility, Port of Edmonds, Washington. June 24, 2004.

Maul Foster & Alongi, Inc. 2001a. Interim Action Report, Unocal Edmonds Terminal. February 28, 2001. SIT5.1

Maul Foster & Alongi, Inc. 2001b. Draft Supplemental Remedial Investigation Work Plan, Unocal Edmonds Terminal, Edmonds, Washington. June, 2001. SIT3.10

Maul Foster & Alongi, Inc. 2002. Lower Yard Interim Action As-Built Report, Unocal Edmonds Terminal, Edmonds WA. November 30, 2002.

Maul Foster & Alongi, Inc. 2003a. Upper Yard Interim Action As-Built Report, Unocal Edmonds Terminal, Edmonds WA. August 25, 2003. SIT5.2

Maul Foster & Alongi, Inc. 2003b. Draft Supplemental Remedial Investigation Report, Unocal Edmonds Terminal, Edmonds, Washington. April 28, 2003. SIT3.12

Maul Foster & Alongi, Inc. 2004a. 2003 Lower Yard Interim Action As-Built Report, Unocal Edmonds Terminal, Edmonds WA. February 26, 2004. SIT5.5

Maul Foster & Alongi, Inc. 2004b. Data Submittal for 2003 Additional Assessment Activities, Unocal Edmonds Terminal. March 2, 2004.

Maul Foster & Alongi, Inc. 2004c. Draft Feasibility Study Report, Unocal Edmonds Bulk Fuel Terminal, Edmonds Washington. March 18, 2004.

Minard, J.P. 1983. Geologic Map of the Edmonds East and Part of the Edmonds West Quadrangles, Washington. U.S. Geological Survey Miscellaneous Field Studies Map MF-1541.

SLR International Corp. 2004a. Results of Site-Wide Groundwater Sampling Event-August 2004, Unocal Edmonds Terminal, Edmonds, Washington. December 2, 2004.

SLR International Corp. 2004b. Surface Water Sampling Results – May through August 2004 Sampling Events, Unocal Edmonds Terminal. November 9, 2004.

SLR International Corp. 2007a. Interim Action Report - Work Plan for 2007 Lower Yard Interim Action, Unocal Edmonds Bulk Fuel Terminal. June 25, 2007. SLR International Corporation.

SLR International Corp. 2007b. Agreed Order for Remedial Action, Lower Yard of Unocal Edmonds Bulk Fuel Terminal, Edmonds Washington. June 25, 2007.

United States Environmental Protection Agency 2015. National Recommended Water Quality Criteria (NRWQC) for marine organisms and humans ingesting organisms <https://www.epa.gov/wqc/national-recommended-water-quality-criteria-human-health-criteria-table>

Washington State Department of Ecology. 2003. Letter RE: Edmonds Bulk Fuel Terminal, Upper Yard: Completion of Cleanup per Interim Action Report. October 9, 2003.

Washington State Department of Ecology. MTCPATPH11.1 Workbook Tool. Revised December 2007.

Washington State Department of Ecology. 2009. Draft Guidance for Evaluating Soil Vapor Intrusion in Washington State: Investigation and Remedial Action. October 2009.

Washington State Department of Ecology. 2014a. Letter Re: Unocal Edmonds Bulk Fuel Terminal – Review of Draft Feasibility Study. May 21, 2014.

Washington State Department of Ecology. 2014b. Letter Re: Unocal Edmonds Bulk Fuel Terminal – Review of Proposed Addendum to the Draft Feasibility Study report. September 23, 2014.

Washington State Highway Commission, Department of Highways, Drainage Plan, July 22, 1971.



Tables

**Table 2-1
Site Investigations and Remedial Actions Chronology
Chevron Environmental Management Company
Interim Action Work Plan
Former Unocal Edmonds Bulk Fuel Terminal
Edmonds, Washington**

Year	Activity	Details	Contaminated Soils Removed (tons)	LNAPL Removed (gal)	Focus Site Area	Report	Author
1986	Phase 1 Site Assessment – GeoEngineers (1986)	<ul style="list-style-type: none"> • Soil, groundwater, and sediment sampling in the Lower Yard. • LNAPL detected in 10 of 27 wells. Thickness ranged from trace to 3.18 feet. Three separate LNAPL plumes were defined. • Depths to groundwater varied from 3 to 8 feet bgs. • Approximately 20,000 gallons of recoverable product are reported to be in the vicinity of the tidal basin. 			Lower Yard	Background History Report Unocal Edmonds Bulk Fuel Terminal	Maul, Foster, and Alongi
1987-1991	Product Recovery Project – GeoEngineers (1987, 1988, 1989, 1991)	<ul style="list-style-type: none"> • Two product recovery systems installed, to the southeast of the tidal basin, and northwest of the facility oil/water separators. • Systems consist of recovery sumps and trenches with perforated drains. • Between May 1988 and September 1990, a total of approximately 7,500 gallons was recovered from RW-1. • RW-2 was never activated, but it is estimated that 1,000 gallons of recoverable petroleum product are located in the former RW-2 area. 		7,500	Lower Yard	Background History Report Unocal Edmonds Bulk Fuel Terminal	Maul, Foster, and Alongi
1988	Subsurface Contamination Study, Upland Fuel Tank Area – GeoEngineers (1988)	<ul style="list-style-type: none"> • Subsurface contamination study to determine conditions within a portion of the Upper Yard. • Consisted of six soil borings, 12 hand auger borings, and installation of groundwater and vapor monitoring wells. • TPH in soil varied from non-detect (ND) to 12,000 milligrams per kilogram (mg/kg), consisting of primarily heavy end hydrocarbons. • Groundwater concentrations were ND for benzene, toluene, ethylbenzene and xylene (BTEX) except for one well with elevated benzene concentrations. 			Upper Yard	Background History Report Unocal Edmonds Bulk Fuel Terminal	Maul, Foster, and Alongi
1988	Phase 1 Site Assessment, Detention Basin No. 1 – GeoEngineers (1988)	<ul style="list-style-type: none"> • Phase 1 assessment of DB-1, surface water, soil and tar samples collected for analysis. • TPH concentrations of the lake sediments and tar exceeded 100,000 mg/kg, ethylbenzene ranged from ND to 3.9 mg/kg, and total xylenes varied from 2 to over 1,000 mg/kg. • No volatile or semivolatile organic compounds were detected in water samples analyzed. TPH concentrations ranged from 560 to 930 µg/L. 			Detention Basin No.1	Background History Report Unocal Edmonds Bulk Fuel Terminal	Maul, Foster, and Alongi

**Table 2-1
Site Investigations and Remedial Actions Chronology
Chevron Environmental Management Company
Interim Action Work Plan
Former Unocal Edmonds Bulk Fuel Terminal
Edmonds, Washington**

Year	Activity	Details	Contaminated Soils Removed (tons)	LNAPL Removed (gal)	Focus Site Area	Report	Author
1989	Phase 2 Site Assessment, Detention Basin No. 1 – GeoEngineers (1989)	<ul style="list-style-type: none"> Investigation to determine the possibility of contamination of groundwater by DB-1. Installed three new monitoring wells and drilled exploratory borings along the northwest margin of the original limits of DB-1. TPH in soil ranged from 65 to 360 mg/kg, TPH in groundwater varied from 0.84 to 1.8 milligrams per liter (mg/L). Benzene ranged from ND to 110 micrograms per liter (µg/L). 			Detention Basin No.1	Background History Report Unocal Edmonds Bulk Fuel Terminal	Maul, Foster, and Alongi
1989	Site Contamination Assessment, Waste Soil Stockpile Area – GeoEngineers (1989)	<ul style="list-style-type: none"> Purpose of the study was to evaluate the waste soil stockpile area (southeast Lower Yard) for subsurface contamination. Five hand auger borings and one groundwater monitoring well installed. Soil in stockpile was from the Unocal Station No. 5353 from 1980, and from Unocal Station No. 6211 from 1987. TPH in soil varied from 510 to 6,300 mg/kg. TPH immediately below or adjacent to the stockpile ranged from ND to 100 mg/kg. The highest benzene concentration was 110 µg/kg. 			Lower Yard	Background History Report Unocal Edmonds Bulk Fuel Terminal	Maul, Foster, and Alongi
1990	Site Contamination Study, Marine Diesel Spill – GeoEngineers (1990)	<ul style="list-style-type: none"> On May 5, 1990, approximately 350 gallons of marine diesel fuel spilled in the Lower Yard. Ten soil samples were analyzed for TPH, results ranged from 9 to 14,000 mg/kg. The highest concentrations were found beneath the aboveground pipe racks. Contamination was noted up to 2 to 3 feet bgs, and estimated to be about 100 cubic yards. 			Lower Yard	Background History Report Unocal Edmonds Bulk Fuel Terminal	Maul, Foster, and Alongi
1990	Site Contamination Assessment, Lower Yard – GeoEngineers (1990)	<ul style="list-style-type: none"> Purpose was to determine the extent of soil contamination due to past releases. Excavated and collecting soil samples from 25 test pits for TPH and BTEX, and evaluated ongoing landfarming activities. Soil samples collected in 23 of 25 test pits between 6 and 8 feet bgs. Benzene concentrations ranged from ND to 3 mg/kg, toluene from ND to 17 mg/kg, ethylbenzene from ND to 43 mg/kg, and total xylenes from ND to 310 mg/kg. TPH varied from 12 to 16,000 mg/kg, TPH-G from ND to 2,800 mg/kg, and TPH-D from ND to 23,000 mg/kg. Landfarming efforts reduced TPH levels from 2,600 mg/kg to less than 200 mg/kg. 			Lower Yard	Background History Report Unocal Edmonds Bulk Fuel Terminal	Maul, Foster, and Alongi

**Table 2-1
Site Investigations and Remedial Actions Chronology
Chevron Environmental Management Company
Interim Action Work Plan
Former Unocal Edmonds Bulk Fuel Terminal
Edmonds, Washington**

Year	Activity	Details	Contaminated Soils Removed (tons)	LNAPL Removed (gal)	Focus Site Area	Report	Author
1991	Supplemental Subsurface Contamination Assessment, Upper Yard – GeoEngineers (1991)	<ul style="list-style-type: none"> • Purpose was to explore subsurface conditions in the eastern portion of the Upper Yard and the BNSF property north of the Lower Yard. • Excavated four test pits, drilled five borings in the eastern portion of the Upper Yard, installed groundwater monitoring wells in each Upper Yard boring, installed 15 hand auger borings throughout the Upper Yard, and installed three borings and groundwater monitoring wells in the BNSF right-of-way. • BTEX components in soil were detected in two of 20 samples. Benzene was not detected in any sample. TPH-G varied from 7 to 2,700 mg/kg, TPH-D ranged from 90 to 19,000 mg/kg, and TPH varied from ND to 30,000 mg/kg. • BTEX components were detected at very low levels in groundwater; TPH-G and TPH-D were ND. 			Upper Yard	Background History Report Unocal Edmonds Bulk Fuel Terminal	Maul, Foster, and Alongi
1991	Harbor Square Phase 1 Site Assessment – Landau Associates (1991)	<ul style="list-style-type: none"> • This assessment was conducted for the Port of Edmonds to assess the nature and extent of potential contamination at a portion of the Port’s Harbor Square property. • Identified a report in Ecology files documenting a leaking 2,000 gallon UST on the BNSF property ~700 feet north of Harbor Square (which was removed in 1990). TPH in soil surrounding the tank ranged from ND to 64,000 mg/kg. • Four soil borings were completed. TPH in soil varied from 2,000 to 4,400 mg/kg, and TPH ranged from ND to 7,900 mg/kg. • The Phase 1 indicated that the source was most likely from the Unocal terminal and the railroad spur on the west side of the Site. 			Harbor Square	Background History Report Unocal Edmonds Bulk Fuel Terminal	Maul, Foster, and Alongi
1991	Harbor Square Phase 2 Site Assessment – Landau Associates (1991)	<ul style="list-style-type: none"> • This assessment was conducted for the Port of Edmonds to assess the nature and extent of potential contamination at a portion of the Port’s Harbor Square property. • Drilled and sampled five soil borings, and installed five monitoring wells. • TPH in soil ranged from 14 to 110,000 mg/kg, PAHs in soil ranged from 2.9 to 680 mg/kg. • It was reported that up to 4 feet of soil was encountered at one location that was saturated with a viscous tar-like substance. • All groundwater results were ND. 			Harbor Square	Background History Report Unocal Edmonds Bulk Fuel Terminal	Maul, Foster, and Alongi

**Table 2-1
Site Investigations and Remedial Actions Chronology
Chevron Environmental Management Company
Interim Action Work Plan
Former Unocal Edmonds Bulk Fuel Terminal
Edmonds, Washington**

Year	Activity	Details	Contaminated Soils Removed (tons)	LNAPL Removed (gal)	Focus Site Area	Report	Author
1992	Preliminary Remedial Investigation – EMCON (1992)	<ul style="list-style-type: none"> • Focused on evaluating the aerial extent of LNAPL plumes. Six soil borings were completed, four of which were completed as groundwater monitoring wells. • TPH-G in soil ranged from ND to 2.7 mg/kg, TPH-D in soil ranged from ND to 2,670 mg/kg, and TPH-O ranged from ND to 2,250 mg/kg. Benzene was not detected in any soil sample. • TPH-G in groundwater ranged from ND to 15 mg/L, TPH-D ranged from ND to 4.96 mg/L, benzene was detected from ND to 0.585 mg/L. 			Lower Yard	Background History Report Unocal Edmonds Bulk Fuel Terminal	Maul, Foster, and Alongi
1992-2000	Free Petroleum Product Recovery Operations - EMCON (1994-1998), MFA (1999-2000)	<ul style="list-style-type: none"> • Four monitoring wells redeveloped, and Welex Environmental, Inc., Hydro-Skimmer units installed in each well for passive recovery of phase-separated petroleum hydrocarbons. • Two of the Hydro-Skimmer units were removed after it was determined that the product was too viscous to pass through the units' filters. • Between December 1992 and September 1993, monitoring wells containing phase separated hydrocarbons were hand-bailed, and the Hydro-Skimmer units were drained, on a biweekly basis. An estimated 100 gallons of petroleum product were recovered by this action. • During 1994, 22 gallons of petroleum product were removed from monitoring wells by hand-bailing. • Starting in 1995, product was pumped on a weekly or biweekly basis from monitoring wells and from Recovery well RW-1 using a peristaltic pump. • 718 gallons of petroleum product were recovered in 1995; 491 gallons were recovered in 1996; 223 gallons were recovered in 1997; 136 gallons were recovered in 1998; and 111 gallons were recovered in 1999. • In 2000, more effective product pumping methods were employed at recovery well RW-1 and 169 gallons of petroleum products were recovered (including 85 gallons from RW-1). 		1,970	Lower Yard	<p>1998 Interim Product Recovery Operations Report</p> <p>2000 Interim Product Recovery Operations Report</p>	<p>EMCON</p> <p>Maul, Foster, and Alongi</p>
1994	UST Decommissioning	<ul style="list-style-type: none"> • Two Lower Yard and three Upper Yard USTs were decommissioned. • Petroleum hydrocarbon products were detected above MTCA Method A cleanup levels, at two of the tank excavations and in one of the product line trenches. 			Upper and Lower Yard	Underground Storage Tank Decommissioning, 1995	EMCON

**Table 2-1
Site Investigations and Remedial Actions Chronology
Chevron Environmental Management Company
Interim Action Work Plan
Former Unocal Edmonds Bulk Fuel Terminal
Edmonds, Washington**

Year	Activity	Details	Contaminated Soils Removed (tons)	LNAPL Removed (gal)	Focus Site Area	Report	Author
1996	Remedial Investigation Report	<ul style="list-style-type: none"> • This RI was performed between October 1994 and August 1996. Field investigation included 31 surface soil samples, 120 shallow soil borings, installation of 39 additional monitoring wells and nine piezometers, 17 basin sediment/soil samples, three test pits, and four trenches. Four quarters of groundwater monitoring were collected, seven monthly rounds of water levels were measured, one round of surface water and storm water samples, and aquifer characterization tests. • LNAPL was found in six Lower Yard plumes. Approximately 8,600 gallons of LNAPL were recovered (1996) and it was estimated that 5,200 gallons of LNAPL remained. LNAPL consisted of TPH-G, TPH-D, and TPH-O. Field observations indicated that much of the LNAPL may have been heavy end hydrocarbons. LNAPL migration rates were estimated to be less than six feet per year. • Dissolved phase hydrocarbons were primarily found near LNAPL plumes, and in areas with LNAPL trapped in the vadose zone. • Zinc was present at elevated levels in groundwater along the perimeter of the Site. • High concentrations of petroleum hydrocarbons in soil were primarily found near LNAPL plumes and in areas with LNAPL trapped in the vadose zone. High concentrations of petroleum hydrocarbons were also found in soil within DB- 1. • Elevated metals concentrations were found in surface soil in areas of sand blast grit and paint chips, but not found in significant concentrations in subsurface soil. • Petroleum-related compounds were detected in onsite stormwater, but at low levels. The highest metal and PAH concentrations were found in surface water upgradient of the Terminal. • Sediment samples passed all criteria for bioassay testing. Limited toxic effects were exhibited in bioassay testing. • Four different vegetation communities were found at the Terminal, but the habitat value was deemed low to moderate. 		8,600	Lower Yard	Draft Remedial Investigation Report, 1998	EMCON

**Table 2-1
Site Investigations and Remedial Actions Chronology
Chevron Environmental Management Company
Interim Action Work Plan
Former Unocal Edmonds Bulk Fuel Terminal
Edmonds, Washington**

Year	Activity	Details	Contaminated Soils Removed (tons)	LNAPL Removed (gal)	Focus Site Area	Report	Author
2001	Interim Action	<ul style="list-style-type: none"> • Consisted of the removal of LNAPL saturated soils from four areas of the Lower Yard. • Excavations were left open for weeks to allow floating LNAPL to be recovered. • 10,763 tons of soil was shipped offsite, 76,237 gallons of product, water, and associated solids were removed from the excavations (including an estimated 2,524 gallons of petroleum product). 	10,763	2,524	Lower Yard	Lower Yard Interim Action As-Built Report, 2002	Maul, Foster, and Alongi
2001	Interim Action	<ul style="list-style-type: none"> • Demolition, removal of ASTs, piping and process structures, excavation and removal of 98,000 tons of impacted soil. 	98,000		Upper Yard	Interim Action Report, 2003	Maul, Foster, and Alongi
2003	Supplemental Remedial Investigation – MFA (2003)	<ul style="list-style-type: none"> • Offsite contamination at the Port of Edmonds South Marina property was investigated. Borings were completed in South Admiral Way. • The highest concentration of DRO was ~2,100 mg/kg, the highest concentration found on the South Marina property is in excess of 20,000 mg/kg. It was determined that the petroleum impacts on the South Marina property were not due to migration from the Terminal. Samples from test pits excavated along the SW Lower Yard contained concentrations of DRO at ~13,000 mg/kg but were ~350 feet from the South Marina Property. • The highest concentrations of TPH in soil were found in the far eastern corner of the Lower Yard, in DB-1, and in the central portion of the Lower Yard. • Groundwater conditions were similar to prior years. • Surface water samples from Willows Creek did not contain concentrations of TPH. • It was determined that it was not likely that TPH was migrating offsite from the Terminal. 			Lower Yard	Supplemental Remedial Investigation Report, 2003	Maul, Foster, and Alongi
2003	Interim Action	<ul style="list-style-type: none"> • Excavation of Detention Basin No.1, the Southwestern Lower Yard, Metals Area 3, and the stormdrain line area. • A total of 39,130 tons of soil were removed. • A total of 1,861,520 gallons of groundwater were extracted from the excavation and effectively treated on site before being discharged into Detention Basin Number 2. 	39,130	1,861,520 (Groundwater removed and treated)	Lower Yard	Lower Yard Interim Action As-Built Report, 2004	Maul, Foster, and Alongi
2007	Phase I - Interim Action	<ul style="list-style-type: none"> • Bulk of soil excavation, 108,000 tons removed and approx. 9,700 gallons of LNAPL recovered. 	108,000	9,700	Lower Yard	Phase I As-Built Report, 2007	ARCADIS
2008	Additional Site Assessment	<ul style="list-style-type: none"> • Soil boring installation, soil sample collection along WSDOT line and other areas of concern in the Lower Yard. 			Lower Yard, WSDOT line	2008 Additional Site Investigation and Groundwater Monitoring Report, 2010	ARCADIS

**Table 2-1
Site Investigations and Remedial Actions Chronology
Chevron Environmental Management Company
Interim Action Work Plan
Former Unocal Edmonds Bulk Fuel Terminal
Edmonds, Washington**

Year	Activity	Details	Contaminated Soils Removed (tons)	LNAPL Removed (gal)	Focus Site Area	Report	Author
2008	Phase II - Interim Action	• Sediments removal, remaining soil excavation. 14,825 tons of soil removed, 131 gallons of LNAPL and 2,000 tons of sediment from Willow Creek.	16,825	131	Lower Yard	Phase II As-Built Report, 2008	ARCADIS
2008	Post-excavation Groundwater Monitoring Program Begins	• Post-excavation groundwater monitoring program begins, POC wells established.			Lower Yard	Reported Annually	ARCADIS
2011	Soil Investigation, Tidal Study, Hydraulic Conductivity Testing	• DB-2 soil and LNAPL investigation, piezometer installation, site-wide tidal study, site-wide hydraulic conductivity testing.			Lower Yard, Willow Creek	Final 2011 Site Investigation Completion Report, 2012	ARCADIS
2012	Monitoring Well Installation, soil sampling, sediment sampling	• Installed monitoring wells MW-525 to MW-532, collected confirmation sediment samples from Willow Creek.			Lower Yard, Willow Creek	Final Conceptual Site Model, 2012	ARCADIS

Table 2-4
 Remaining Impacts - Soil Sample Locations
 Chevron Environmental Management Company
 Interim Action Work Plan
 Former Unocal Edmonds Bulk Fuel Terminal
 Edmonds, Washington

Soil Sample Location	Cleanup Action / Investigation	Location	Concentration (mg/kg) exceeded Site			Remarks			
			REL for TPH* (2,775 mg/kg)	CUL for cPAHs TEQ (0.14mg/kg)	CUL for benzene (18 mg/kg)				
STRM-6FLOOR-7	2003 Point Edwards Storm Drain Line Excavation	Point Edwards Storm Drain Line	17,439	-	54.9	These samples location were not over-excavated. The Point Edwards Storm Drain Line Excavation was conducted to facilitate installation of a new stormwater outfall for Point Edwards, and was not specifically intended as a remedial action. These locations will be remediated through the DPE system.			
STRM-4WALLE(2)-3			15,388	0.56	-				
SWLY-D-3 Wall-3.75	2003 Excavation	Southwest Lower Yard	2,923	-	-	This sample location was not over-excavated. TPH concentration of this sample was below the REL for TPH (3,000 mg/kg).			
EX-B11-U-10-SSW-5	2007 - Phase I excavation activities	Close to the WSDOT stormwater line	-	0.159	-	These sample locations were not over-excavated to preserve the integrity of the WSDOT stormwater line. These locations will be remediated through the DPE system.			
EX-A2-Q-14-6			3,060	-	-				
EX-A2-O-15-SSW-6			7,540	-	-				
EX-A2-N-16-SSW-6			7,550	-	-				
EX-B20-M-17-SSW-6			15,700	0.166	-				
EX-B18-VV-1-6SW	2008 - Phase II excavation activities	Close to the BNSF Railway	4,980	-	-	Soil in the area of this sample was not over-excavated because of its location on the property boundary between the Lower Yard and the BNSF Railway right-of-way. Soil was removed up to the property boundary, but excavation activities were ceased to maintain the integrity of the BNSF Railway line.			
EX-B1-F-44-4		Southeast Lower Yard	-	0.212	-	Soil in the area of this sample was not over-excavated.			
MW129R-7.0	2008	Northeast Lower Yard	3,007	-	-	Sample collected during the installation of monitoring well MW-129R was not removed.			
SB-65-6.5		Close to the WSDOT stormwater line	16,900	1.01	35.8	These sample locations were not over-excavated during the Phase II Excavation activities in 2008 to preserve the integrity of the WSDOT stormwater line. These locations will be remediated through the DPE system.			
SB-66-6.0			11,900	0.209	-				
SB-68-4.0			5,470	0.165	-				
SB-69-6.0			3,720	0.236	-				
SB-80-7.5			4,660	0.693	-				
B-4-9.5-10	2011		Near DB-2, monitoring well MW-510, and Willow Creek	4,413	-		-	These locations will be excavated.	
B-5-9.5-10		27,021		-	-				
B-6-9-9.5		220,400		3.2	-				
B-7-8-8.5		111,400		2.8	-				
B-8-9.5-10		75,730		0.5	-				
B-9-8.5-9		20,970		0.29	-				
B-10-0.5-1		-		0.2	-				
B-11-10-10.5		37,150		3.4	-				
B-13-7-7.5		15,900		-	-				
B-16-4-4.5		-		0.145**	-				
B-17-(depth varies)		22,201 (4-4.5 ft)		116* (4.5-5 ft)	-				
MW-525-6		2012		Close to the WSDOT stormwater line	17,850	0.29	34		These locations will be remediated through the DPE system.
MW-532-7					10,540	-	-		

NOTES:

In 2003, the Site interim action REL for TPH was 3,000 mg/kg. In 2007/2008, the Site interim action REL for TPH was 2,975 mg/kg.

*The GC/MS semivolatile internal standard peak areas were outside of the QC limits for both the initial injection and the re-injection. The values here are from the initial injection of the sample.

** This data point was previously reported as .1 in the 2011 Investigation tables. Analytical results report it as 0.145

CUL = Cleanup level

REL = Remediation level

- = concentration below appropriate CULs/RELS

mg/kg = milligrams/kilograms

TEQ = Total cPAHs adjusted for toxicity

cPAHs = Carcinogenic polycyclic aromatic hydrocarbons

TPH = Total petroleum hydrocarbons

Table 2-6
2013 Soil Vapor Analytical Results
Chevron Environmental Management Company
Interim Action Work Plan
Former Unocal Edmonds Bulk Fuel Terminal
Edmonds, Washington

Sample ID	Sample Depth (ft bgs)	Sample Date	Analytical Method	Dilution Factor	Benzene	Naphthalene	Σ(C5-C6AL)+(>C6-C8AL)	Σ(>C8-C10AL)+(>C10-C12AL)	>C8-C10AR	>C10-C12AR	Oxygen	Methane	Carbon Dioxide	Helium
Analysis Method (units)					TO-15 GC/MS (µg/m ³)						ASTM D-1946 (%)			
VP-1	5	10/09/13 ²	TO-17	4	>530,000 SJ	9,700 J	NA	NA	NA	NA	5.0	>5.0	2.62	6.4 ³
		11/21/13	TO-15	108	710,000	ND<11,000	35,000,000	6,600,000	34,000	ND<120,000	2.6	29	11	ND<0.11
VP-2	5	10/09/13 ²	TO-15	1	940	ND<40	23,400	37,000	ND<1,100	ND<1,200	1.8	2.0	8.0	ND<0.11
		10/09/13 ²	TO-17	22.4	310	ND<230	NA	NA	NA	NA	4.8	1.7	1.92	0.19 ³
		11/21/13	TO-15	9.04	340	ND<95	33,700	36,000	1,200	ND<500	1.6	2.6	12	ND<0.11
(DUP)				8.48	300	ND<89	27,800	25,000	1,000	ND<460	4.0	2.3	10	ND<0.11
VP-3	5	10/09/2013 ²	TO-17	1.00	190	8.5	NA	NA	NA	NA	5.4	>5.0	2.1	4.5 ³
		11/21/13	TO-15	21.0	46	ND<220	529,000	305,000	ND<1,700	ND<1,900	1.3	23	11	ND<0.10
Field Blank	NA	10/09/2013 ²	TO-17	1.00	ND<21	ND<1.7	NA	NA	NA	NA	NA	NA	NA	NA
Equipment Blank	NA	10/09/2013 ²	TO-15	2.33	31	ND<6.1	4,530	1,870	210	ND<130	0.79	0.0015	ND<0.023	ND<0.12
Equipment Blank	NA	11/21/13	TO-15	2.10	ND<0.67	ND<5.5	ND<154	ND<270	ND<100	ND<120	2.5	ND<0.00021	ND<0.021	ND<0.10
DOE Method B Soil Gas Screening Levels for Shallow Soil Gas¹					3.2	14	27,000	1,400	1,800	NA	NA	NA	NA	NA

NOTES:

Concentrations are in micrograms per cubic meter (µg/m³).

Highlighted cells indicate detected concentrations above the Ecology Method B Screening Level.

Greyed data was collected during the October 2013 sampling event and was not used for data evaluation.

Fixed gas data for TO-17 samples was collected in the field.

DUP = Duplicate sample

¹Sub-slab or shallow soil gas screening level just beneath a building or less than 15 feet bgs.

²Equipment blank results indicate potential contamination of sampling equipment. Data collected during this sampling event are considered questionable.

³Methane causes interference with helium detector and these readings are indicative of methane. To prove the readings were methane interference, the concentration of helium inside the shroud was more than doubled, to 50%; however, a corresponding increase in the helium was not observed.

J = Estimated value due to bias in the Continuous Calibration Value (CCV)

S = Saturated peak; data reported as estimated

<ND = Non-detect, Value listed is laboratory reporting limit.

ft bgs = feet below ground surface

NA = Not applicable.

Table 15-1
Chevron Environmental Management Company
Former Unocal Edmonds Bulk Fuel Terminal
Edmonds, Washington

Item #	Deliverable Description	Planned Schedule*
1	Progress Reports	
	Progress reports will include draft soil, groundwater, and vapor monitoring data.	By the 15th of the next month, unless otherwise approved by Ecology
2	EIM submittals	
	Soil, groundwater, and vapor monitoring data will be submitted to EIM.	Within 1 month of receipt of validated data
3	Interim Action Work Plan (IAWP)	
	IAWP directs remediation work to be performed at the Site.	Final IAWP delivered to Ecology 07/19/2016
4	Dual-Phase Extraction (DPE) Pilot Test Memo	
	DPE Pilot Test Memo (Memo) reports the results of the pilot test conducted to check if DPE system will be effective at the Site.	Final delivered to Ecology - 03/08/2016
5	Engineering Design Report (EDR) and Construction Plans and Specification (CPS) for the DPE System and DB-2 Excavation	
	EDR documents engineering concepts, and design criteria. This report also establishes operation parameters, assumptions, and calculation of capture zone, along with the system design construction plans and specifications. CPS for DB-2 excavation provides design drawings and specifications for the planned excavation construction activities.	Final EDR delivered to Ecology - 03/08/2016
6	DPE System Operations and Maintenance Manual (OMM)	
	The OMM will detail DPE system operation and performance monitoring requirements.	Final OMM to Ecology - 06/14/2017*
7	Final Feasibility Study Report	
	Final Feasibility Study Report (FS Report) summarizes previous remedial actions and establishes final remedial actions.	Public Review Draft FS Report - 06/16/2017* Final Public Review FS Report - 30 days after receipt of Ecology comments subsequent to public comment period to be scheduled
8	Remedial Activities	
	Baseline monitoring event Ecology review draft work plan	6/16/2017
	Baseline monitoring event final work plan	15 days after receipt and incorporation of Ecology comments
	Baseline monitoring event	30 days or less prior to starting remediation system
	Excavation of DB-2 and installation and start-up of DPE system	Excavation of DB-2 - Third quarter 2017 DPE system installation and start-up - by 12/31/2017
9	Cleanup Action Plan	
	Preliminary Draft Cleanup Action Plan (CAP) will detail the cleanup actions evaluated in the Final FS to comply with WAC 173-340-350 through 173-340-390 and identify the DB-2 excavation and operation of the DPE system as Chevron's the preferred remedy. A Compliance Monitoring Plan provided as appendix of the CAP will detail the soil and groundwater sampling requirements which will be needed to confirm that remediation has met the cleanup levels at the points of compliance for the Site as defined in the CAP. The Compliance Monitoring plan will provide procedures to evaluate remediation progress and to evaluate when remediation is complete, including requirements for monitoring reports and a schedule for monitoring report submittal. The Compliance Monitoring Plan will include contingency actions to be implemented if compliance monitoring indicates cleanup standards will not be achieved within the restoration time frame specified in the CAP.	Preliminary Draft CAP to Ecology - 07/31/2017*
	Public Review Draft Cleanup Action Plan will incorporate Ecology's comments on the Preliminary Draft Cleanup Action Plan and identify Ecology's selected remedy for the Site.	Public Review Draft CAP to Ecology within 90 days of receipt of Ecology's comment on and required revision of the Preliminary Draft CAP.
10	As-Built Report for the DB-2 Excavation and DPE System Installation	
	As-Built Report for the DB-2 Excavation will document details of the construction and any deviation from the work plan along with As-built drawings.	Draft DB-2 Excavation As-Built Report to Ecology - 01/31/2018* Final As-Built Report - due 30 days after receipt of Ecology comments
	As-Built Report for the DPE system installation will document details of the construction and any deviation from the work plan along with As-built drawings.	Draft DPE System Installation As-Built Report to Ecology - 01/31/2018* Final As-Built Report - due 30 days after receipt of Ecology comments
11	Yearly Groundwater and Operation Reports	
	The reports will include an overview of operation of the DPE system (adjustments, changes to the system, problems), groundwater table contour maps, and an estimate of the mass of hydrocarbons removed as LNAPL as well as in the aqueous and vapor phases, based on system measurements.	Annually

Notes:

EIM: Ecology's Electronic Information Management (EIM) database

work completed

MTCA: Model Toxics Control Act

*: These dates are contingent on: (a) existing permits not being modified and remaining in place; (b) the Washington State Department of Ecology's (Ecology) timely review, approval, and modification of documents submitted by Chevron Environmental Management Company (Chevron); and (c) circumstances beyond the reasonable control of Chevron. If any delays occur as a result of these events, Chevron may request an Extension of Schedule as provided for in AO No. DE 4460, Section VIII.K.



Figures

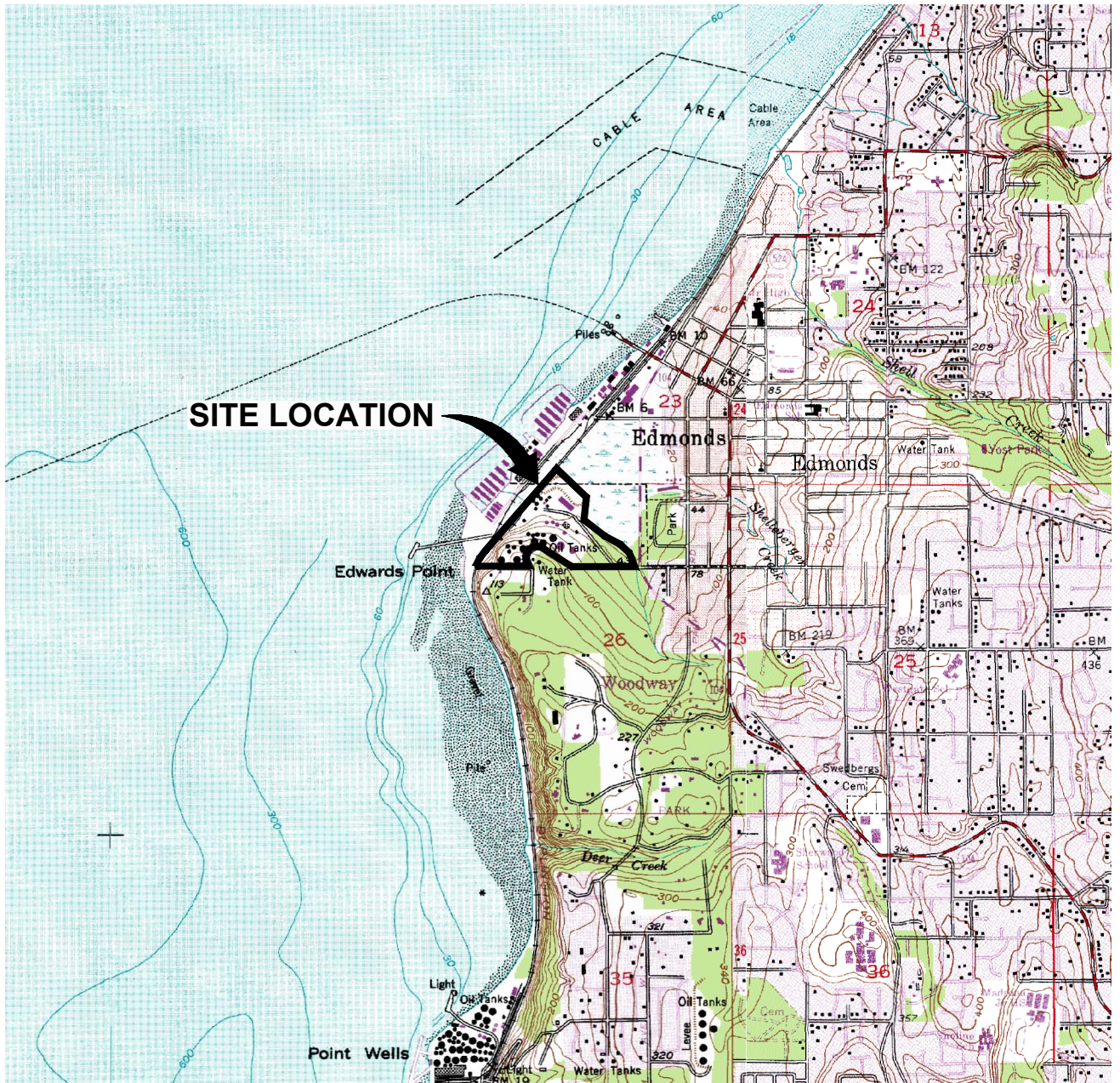

REFERENCE: USGS QUADS., 7.5 MIN. SERIES (TOPOGRAPHIC) - EDMONDS EAST, WASH. AND EDMONDS WEST, WASH.

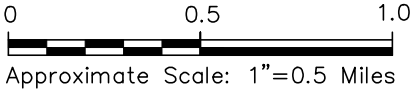

CHEVRON ENVIRONMENTAL MANAGEMENT COMPANY
 FORMER UNOCAL BULK FUEL TERMINAL
 EDMONDS, WASHINGTON
INTERIM ACTION WORK PLAN

SITE LOCATION MAP



FIGURE
1-1

CITY: EMV, CA DIV/GROUP: ENVCAD DB: ASR PM: TME TR: LVR: ON="OFF" REF: (FR) I:\acad\proj\B004532\AWP\DWG\B004532 B02-1.dwg LAYOUT: 2-1 SAVED: 5/18/2015 1:23 PM ACADVER: 18.1S (LMS TECH) PAGESETUP: FULL PLOTSTYLETABLE: PLTHALF.CTB PLOTTED: 5/18/2015 1:23 PM BY: HUTCHINS-WASS, TABITHA XREFS: IMAGES: PROJECTNAME: 48362X02 48362X03

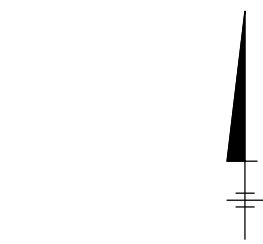
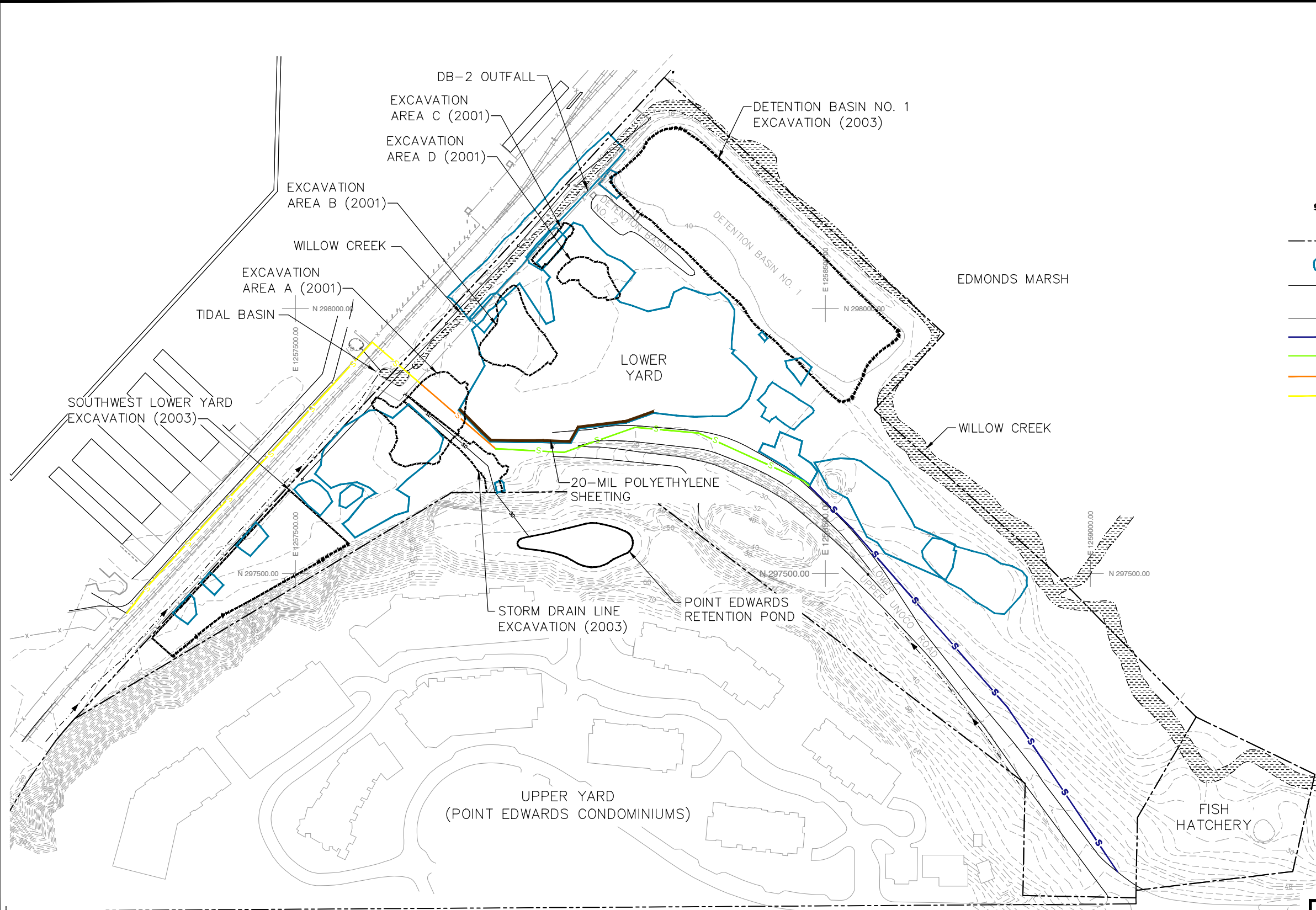

- LEGEND:**
- 2001 AND 2003 SOIL EXCAVATIONS BELOW GROUNDWATER TABLE
 - PROPERTY BOUNDARY
 - 2007/2008 EXCAVATION BOUNDARIES
 - WSDOT STORMWATER LINE (DIAMETER OF STORMWATER LINE INDICATED BY COLOR)
 - POINT EDWARDS STORM DRAIN LINE
 - 48" DIAMETER STORMWATER LINE
 - 54" DIAMETER STORMWATER LINE
 - 60" DIAMETER STORMWATER LINE
 - 72" DIAMETER STORMWATER LINE

- NOTES:**
1. 20-MIL POLYETHYLENE SHEETING INSTALLED UPON COMPLETION OF PHASE I OF THE 2007/2008 EXCAVATION. SHEETING REACHES TO APPROXIMATELY 7.5 FEET ABOVE MEAN SEA LEVEL.
 2. HORIZONTAL DATUM: WASHINGTON STATE COORDINATE SYSTEM NORTH ZONE (NAD 83/98). VERTICAL DATUM: N.A.V.D. 88. UNITS: U.S. SURVEY FEET. HORIZONTAL AND VERTICAL CONTROL ESTABLISHED BY GPS VIA VERTICAL REFERENCE STATION NETWORK (VRSN).
 3. SOUTHEAST PORTION OF WSDOT STORMWATER LINE HAS NOT BEEN SURVEYED.
 4. THE LOCATION OF THE CHANGES IN DIAMETER OF THE WSDOT STORMWATER LINE ARE APPROXIMATE.
 5. PORTION OF POINT EDWARDS STORM DRAIN LINE EXTENDING IN THE UPPER YARD AND POINT EDWARDS RETENTION POND HAVE NOT BEEN SURVEYED.

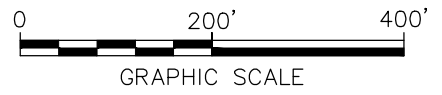

CHEVRON ENVIRONMENTAL MANAGEMENT COMPANY
FORMER UNOCAL BULK FUEL TERMINAL
EDMONDS, WASHINGTON
INTERIM ACTION WORK PLAN

SITE LAYOUT

FIGURE
2-1

CITY: EMV, CA DIV/GROUP: ENV/CAD, DB: ASR, PM: TWE, TR: LVR, ON: OFF=REF, (FRZ)
 C:\Users\hutchinsw\OneDrive\Documents\B02-2.dwg LAYOUT: 2-2, SAVER: 2/9/2015 11:12 PM, ACADVER: 18, IS (LMS TECH), PAGES: 18, PLOTSTYLETABLE: PLTHALF.CTB, PLOTTED: 2/10/2015 12:57 PM, BY: HUTCHINS-WASS, TAB: THA

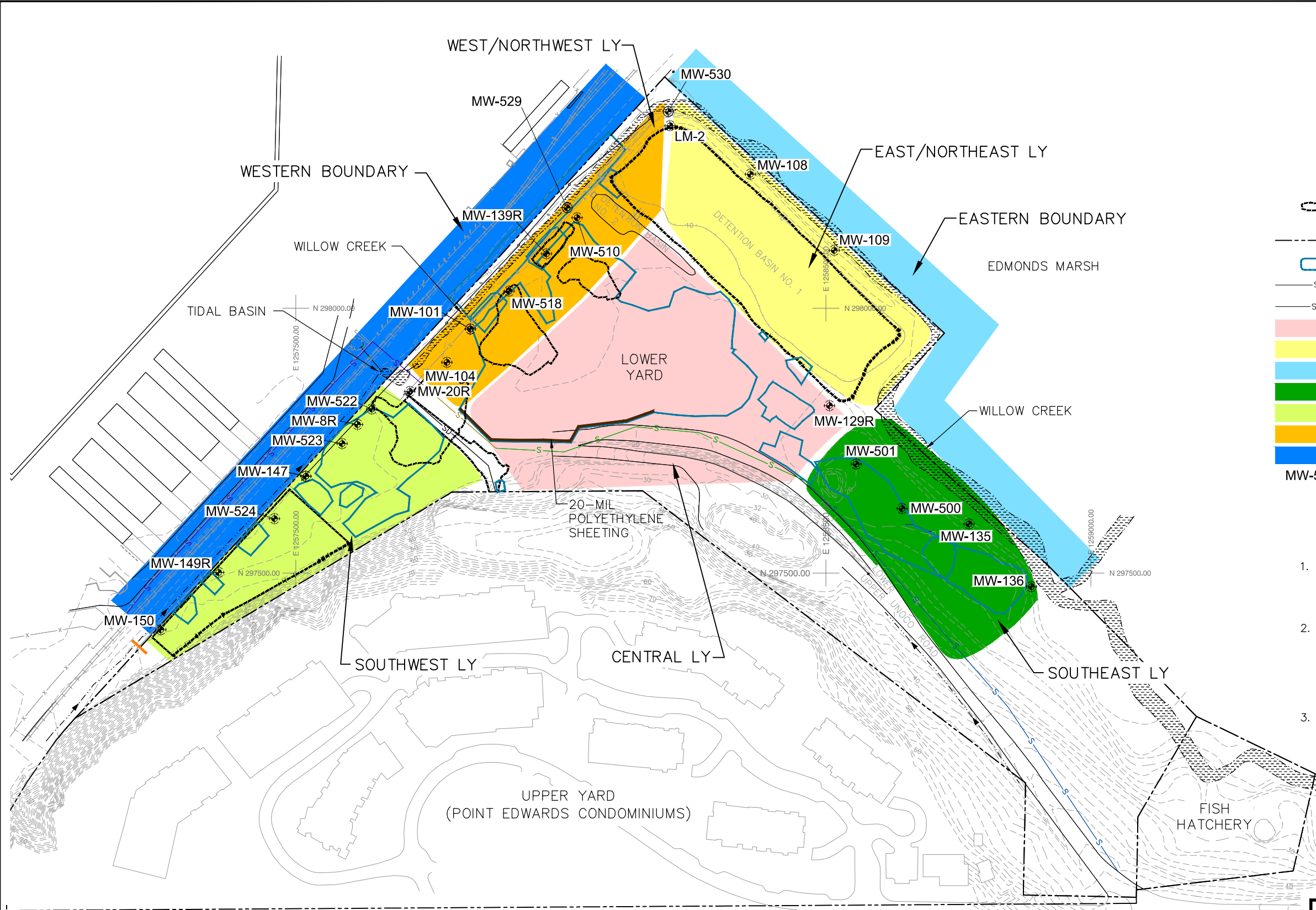

LEGEND:

- 2001 AND 2003 SOIL EXCAVATIONS BELOW GROUNDWATER TABLE
- PROPERTY BOUNDARY
- 2007/2008 EXCAVATION BOUNDARIES
- WSDOT STORMWATER LINE
- POINT EDWARDS STORM DRAIN LINE
- CENTRAL LY
- EAST/NORTHEAST LY
- EASTERN BOUNDARY
- SOUTHEAST LY
- SOUTHWEST LY
- WEST/NORTHWEST LY
- WESTERN BOUNDARY
- MW-529 PERIMETER MONITORING WELL LOCATION

NOTES:

1. 20-MIL POLYETHYLENE SHEETING INSTALLED UPON COMPLETION OF PHASE I EXCAVATION. SHEETING REACHES TO APPROXIMATELY 7.5 FEET ABOVE MEAN SEA LEVEL.
2. HORIZONTAL DATUM: WASHINGTON STATE COORDINATE SYSTEM NORTH ZONE (NAD 83/98). VERTICAL DATUM: N.A.V.D. 88. UNITS: U.S. SURVEY FEET. HORIZONTAL AND VERTICAL CONTROL ESTABLISHED BY GPS VIA VERTICAL REFERENCE STATION NETWORK (VRSN).
3. SOUTHEAST PORTION OF WSDOT STORMWATER LINE HAS NOT BEEN SURVEYED.



CHEVRON ENVIRONMENTAL MANAGEMENT COMPANY
 FORMER UNOCAL BULK FUEL TERMINAL
 EDMONDS, WASHINGTON
INTERIM ACTION WORK PLAN

AREAS OF THE LOWER YARD MAP



CITY: EMV, CA DIV/GROUP: ENV/CAD DB: ASR PM: TME TR: LVR: ON=OFF=REF: (FRZ)
 G:\ENV\CAD\Emery\11a\ACT\B04536200500003\AMVP\DWG\B045362 802-3.dwg LAYOUT: 2-3
 XREFS: 45362X02 45362X01
 IMAGES: PROJECTNAME: --- PLOTSTYLE/TABLE: PLTHALF.CTB PAGESETUP: --- PLOTTED: 10/28/2014 10:55 AM BY: REYES, ALEC
 ACADVER: 18.1S (LMS TECH) PAGESETUP: ---

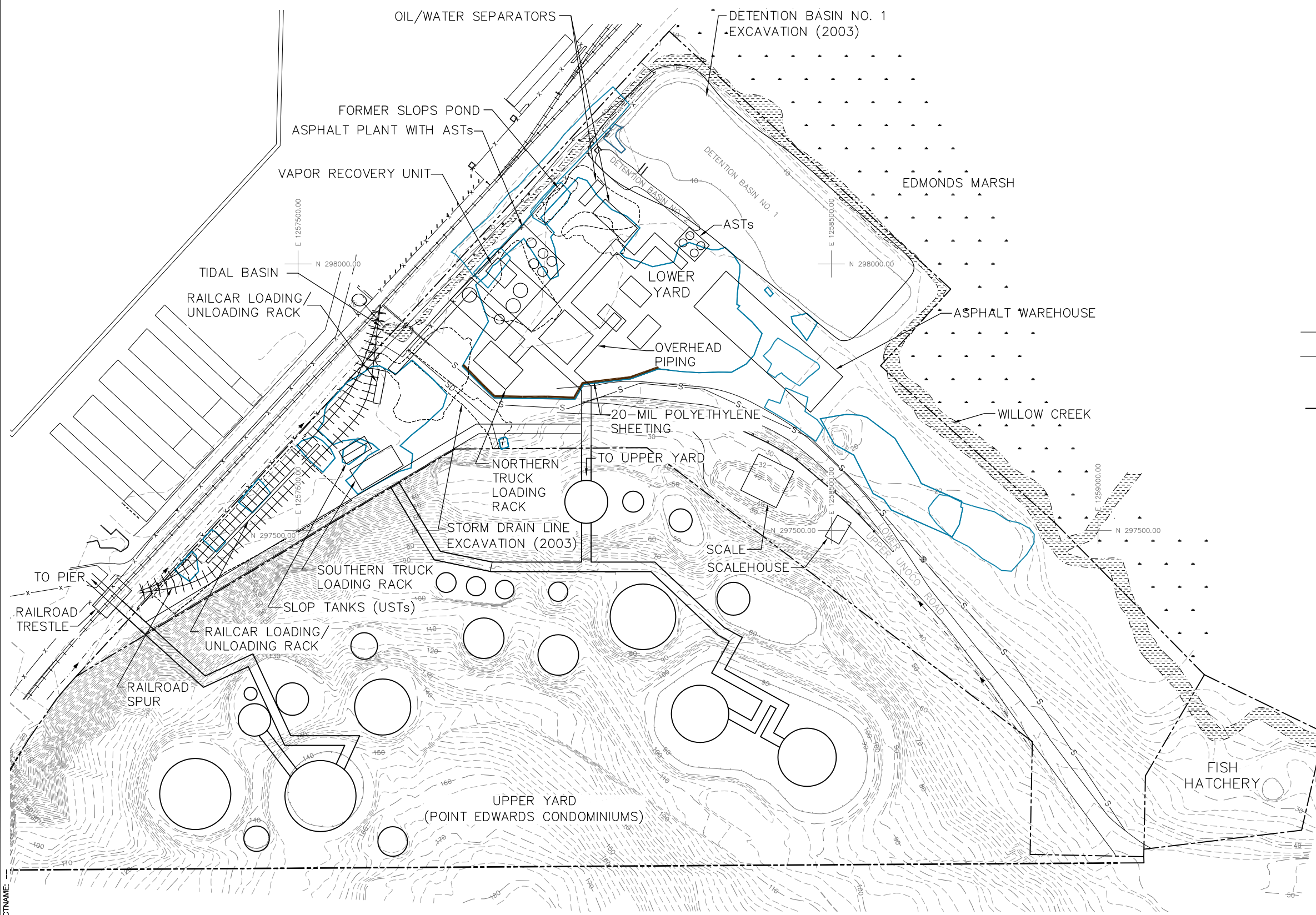

- LEGEND:**
- 2001 AND 2003 SOIL EXCAVATIONS BELOW GROUNDWATER TABLE
 - 2007/2008 EXCAVATION BOUNDARIES
 - WSDOT STORMWATER LINE
 - POINT EDWARDS STORMWATER LINE
 - HISTORICAL FEATURE
 - PROPERTY BOUNDARY

- NOTES:**
1. 20-MIL POLYETHYLENE SHEETING INSTALLED UPON COMPLETION OF PHASE I EXCAVATION. SHEETING REACHES TO APPROXIMATELY 7.5 FEET ABOVE MEAN SEA LEVEL.
 2. HORIZONTAL DATUM: WASHINGTON STATE COORDINATE SYSTEM NORTH ZONE (NAD 83/98). VERTICAL DATUM: N.A.V.D. 88
 UNITS: U.S. SURVEY FEET
 HORIZONTAL AND VERTICAL CONTROL ESTABLISHED BY GPS VIA VERTICAL REFERENCE STATION NETWORK (VRSN).
 3. SOUTHEAST PORTION OF WSDOT STORMWATER LINE HAS NOT BEEN SURVEYED.



CHEVRON ENVIRONMENTAL MANAGEMENT COMPANY
 FORMER UNOCAL BULK FUEL TERMINAL
 EDMONDS, WASHINGTON
INTERIM ACTION WORK PLAN

HISTORICAL FACILITIES LOCATION MAP

ARCADIS

FIGURE
2-3

CITY: EMV_CA DIV/GROUP: ENV/CAD DB: ASR PM: TME TR: LVR: ON="OFF=REF" (FRZ)
 C:\Users\hutchinsw\OneDrive\Documents\B02-4.dwg LAYOUT: 2-4 SAVED: 2/6/2015 8:22 AM ACADVER: 18.15 (LMS TECH) PAGES: 18 PLOTTED: 2/6/2015 1:23 PM BY: HUTCHINS-WASS, TABITHA
 XREFS: 45362X02 45362X03 PROJECTNAME:

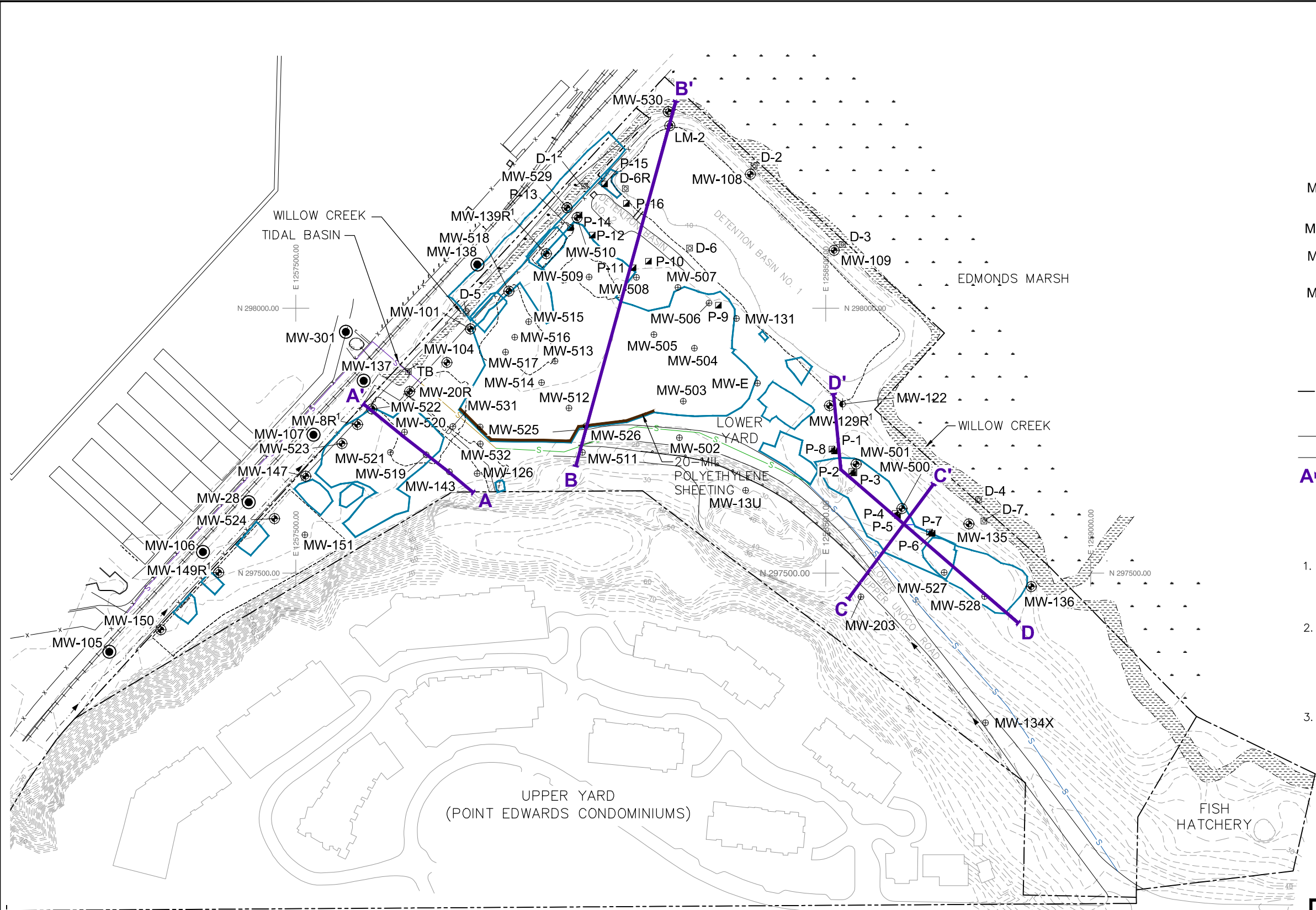

LEGEND:

- MW-203 ⊕ INTERIOR MONITORING WELL LOCATION AND DESIGNATION
- MW-105 ● BNSF WELLS
- MW-122 ⊕ DEEP MONITORING WELL LOCATION AND DESIGNATION
- MW-109 ⊕ PERIMETER MONITORING WELL LOCATION
- P-11 ▣ PIEZOMETER
- D-1 ▣ STAFF GAUGE
- 2001 AND 2003 SOIL EXCAVATIONS BELOW GROUNDWATER TABLE
- - - PROPERTY BOUNDARY
- ▭ 2007/2008 EXCAVATION BOUNDARIES
- S- WSDOT STORMWATER LINE
- SD- POINT EDWARDS STORM DRAIN LINE
- A-A' CROSS SECTION LOCATIONS

NOTES:

1. 20-MIL POLYETHYLENE SHEETING INSTALLED UPON COMPLETION OF PHASE I EXCAVATION. SHEETING REACHES TO APPROXIMATELY 7.5 FEET ABOVE MEAN SEA LEVEL.
2. HORIZONTAL DATUM: WASHINGTON STATE COORDINATE SYSTEM NORTH ZONE (NAD 83/98).
 VERTICAL DATUM: N.A.V.D. 88
 UNITS: U.S. SURVEY FEET
 HORIZONTAL AND VERTICAL CONTROL ESTABLISHED BY GPS VIA VERTICAL REFERENCE STATION NETWORK (VRSN).
3. SOUTHEAST PORTION OF WSDOT STORMWATER LINE HAS NOT BEEN SURVEYED.



CHEVRON ENVIRONMENTAL MANAGEMENT COMPANY
 FORMER UNOCAL BULK FUEL TERMINAL
 EDMONDS, WASHINGTON
INTERIM ACTION WORK PLAN

CROSS SECTION LOCATION MAP



FIGURE
2-4

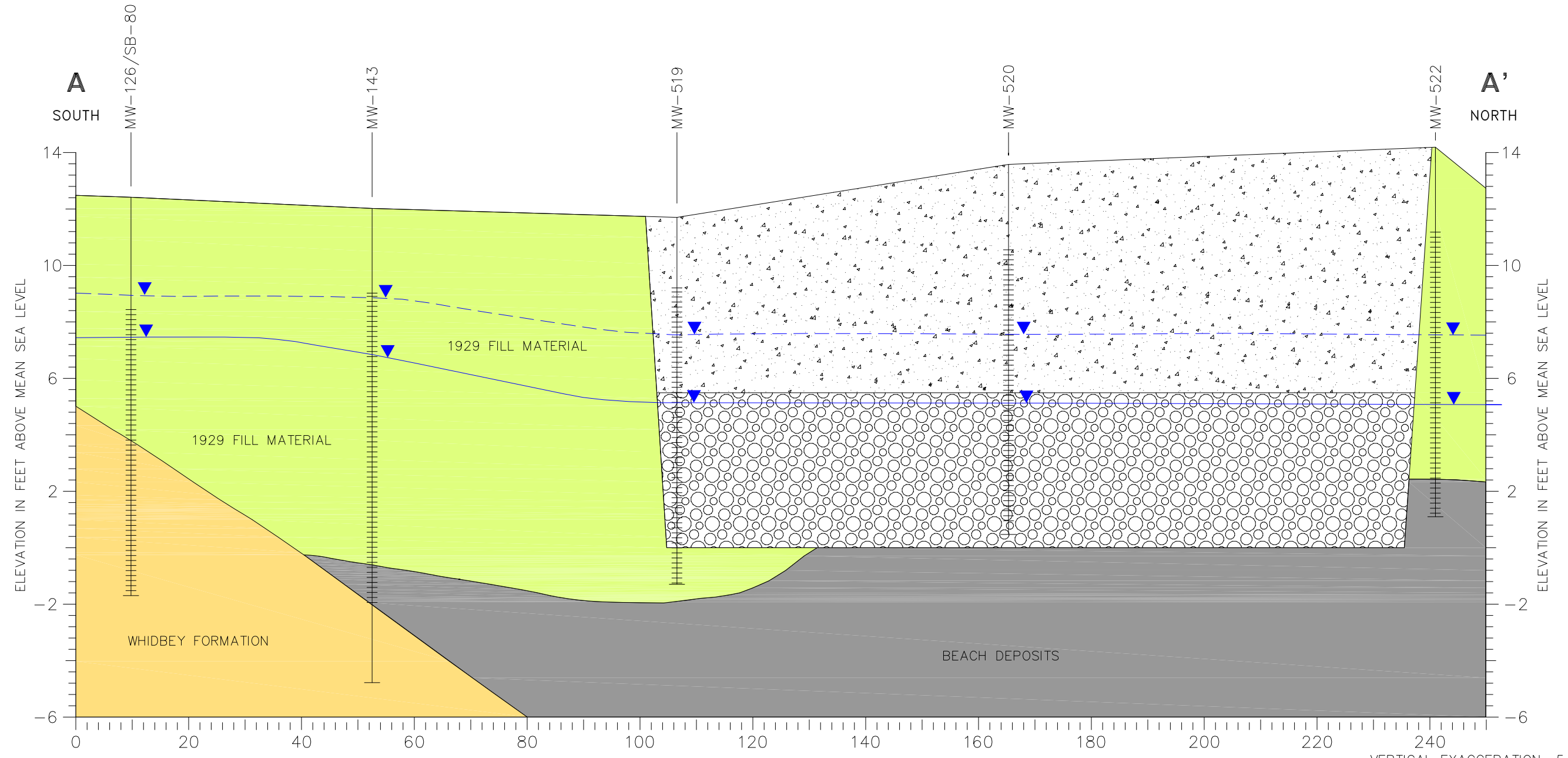

NOTES:

- HORIZONTAL DATUM: WASHINGTON STATE COORDINATE SYSTEM NORTH ZONE (NAD 83/98).
- VERTICAL DATUM: N.A.V.D. 88
- UNITS: U.S. SURVEY FEET
- HORIZONTAL AND VERTICAL CONTROL ESTABLISHED BY GPS VIA VERTICAL REFERENCE STATION NETWORK (VRSN).

LEGEND:

- MW-126 WELL OR BORING ID
- GROUND SURFACE
- ▲ HISTORICAL HIGH WATER LEVEL
- ▼ HISTORICAL LOW WATER LEVEL
- LITHOLOGIC CONTACT (DASHED WHERE INFERRED)
- ||||| SCREENED INTERVAL
- └─── BOTTOM OF BORING

- 1929 FILL MATERIAL
- BEACH DEPOSITS
- TRANSITIONAL SILT BED
- WHIDBEY FORMATION
- MARSH DEPOSITS
- 2007/2008 FILL (GRAVEL)
- 2007/2008 FILL (SILT, SAND AND GRAVEL)

(35' SE) = OFFSET DISTANCE FROM CROSS SECTION PROFILE

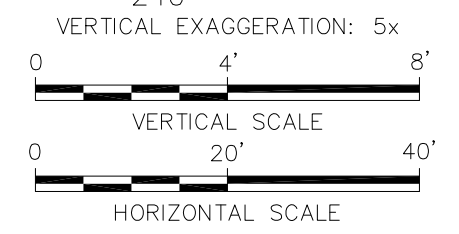

CHEVRON ENVIRONMENTAL MANAGEMENT COMPANY
 FORMER UNOCAL BULK FUEL TERMINAL
 EDMONDS, WASHINGTON
INTERIM ACTION WORK PLAN

**LOWER YARD
 GEOLOGIC CROSS SECTION A-A'**

FIGURE
2-5

CITY: PHOENIX, AZ DIV/GROUP: ENVCAD DB: A. REYES, T. HUTCHINS-WASS, J. HARRIS
 C:\Users\jharris\Desktop\ENVCAD\RETURN\TO\PHOENIX_AZ\B0045362\0006\0002\IAV\DWG\B0045362_V02-6.dwg LAYOUT: 2-6 SAVED: 2/9/2015 2:11 PM ACADVER: 18.1S (LMS TECH) PAGES: 1 PLOTSTYLETABLE: PLTHALF.CTB PLOTTED: 2/9/2015 2:12 PM BY: HARRIS, JESSICA
 XREFS: IMAGES: PROJECTNAME: 1

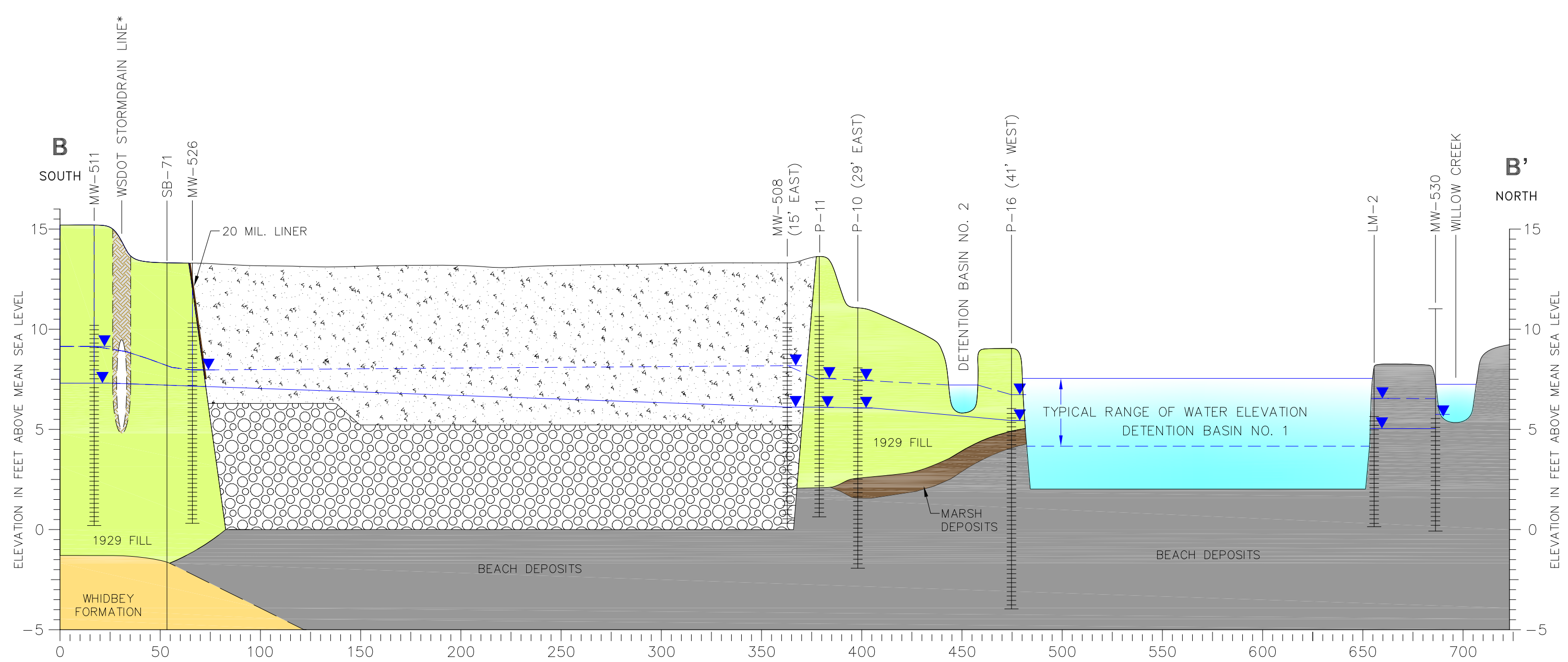

NOTES:

1. WSDOT STORMDRAIN LINE LOCATION IS APPROXIMATE AND DRAWN TO A NON EXAGGERATED SCALE FOR CLARITY.
2. HORIZONTAL DATUM: WASHINGTON STATE COORDINATE SYSTEM NORTH ZONE (NAD 83/98). VERTICAL DATUM: N.A.V.D. 88 UNITS: U.S. SURVEY FEET HORIZONTAL AND VERTICAL CONTROL ESTABLISHED BY GPS VIA VERTICAL REFERENCE STATION NETWORK (VRSN).

- LEGEND:**
- MW-511 WELL OR BORING ID
 - GROUND SURFACE
 - HISTORICAL HIGH WATER LEVEL
 - HISTORICAL LOW WATER LEVEL
 - LITHOLOGIC CONTACT (DASHED WHERE INFERRED)
 - SCREENED INTERVAL
 - BOTTOM OF BORING

- DISTURBED TRENCH MATERIAL
 - 1929 FILL MATERIAL
 - BEACH DEPOSITS
 - WHIDBEY FORMATION
 - MARSH DEPOSITS
 - 2007/2008 FILL (GRAVEL)
 - 2007/2008 FILL (SILT, SAND AND GRAVEL)
- (29' E) = OFFSET DISTANCE FROM CROSS SECTION PROFILE

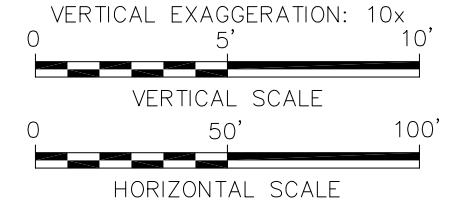

CHEVRON ENVIRONMENTAL MANAGEMENT COMPANY
 FORMER UNOCAL BULK FUEL TERMINAL
 EDMONDS, WASHINGTON
INTERIM ACTION WORK PLAN

**LOWER YARD
 GEOLOGIC CROSS SECTION B-B'**

ARCADIS

FIGURE
2-6

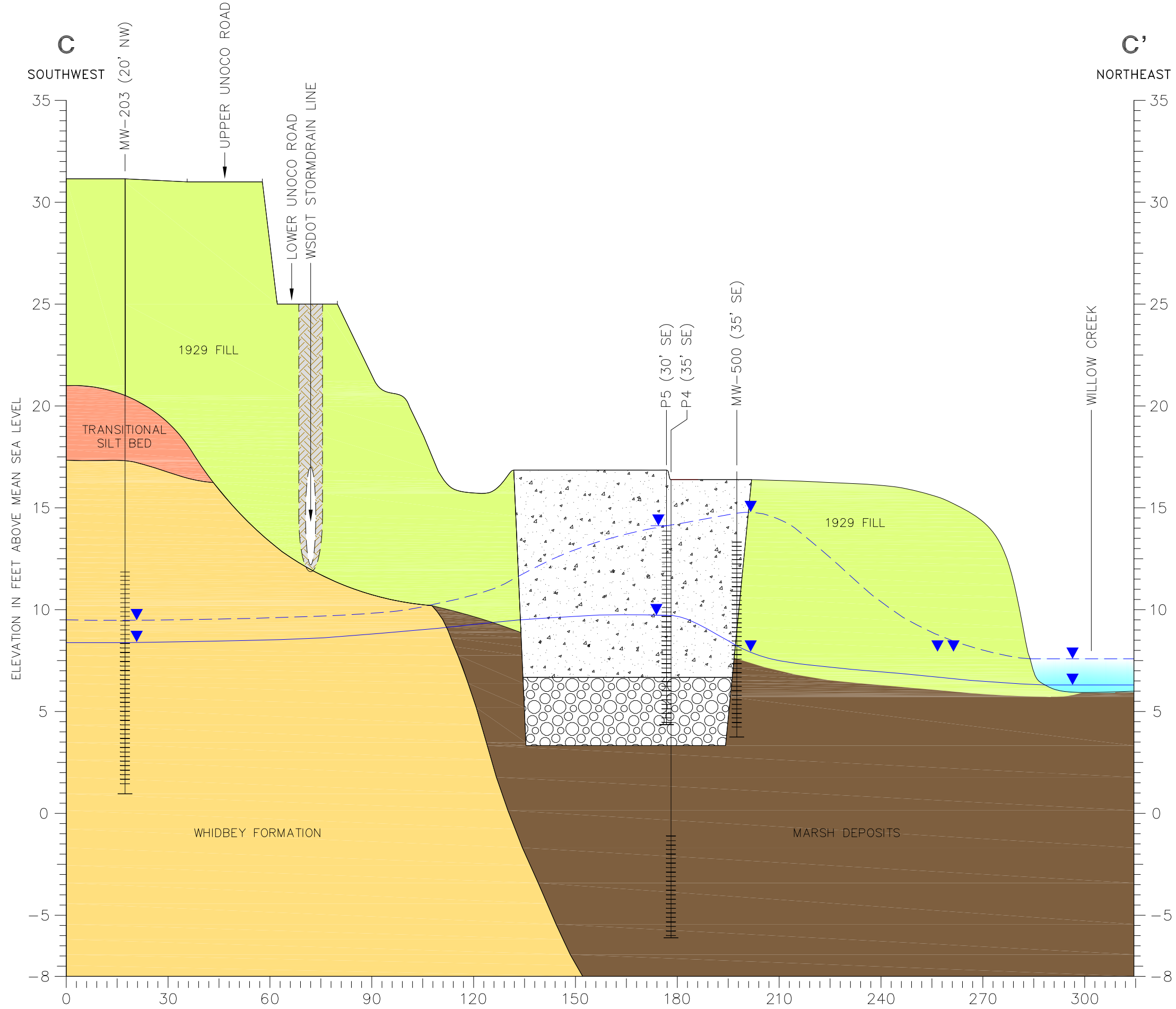

LEGEND:

- MW-500 WELL OR BORING ID
- GROUND SURFACE
- - - HISTORICAL HIGH WATER LEVEL
- HISTORICAL LOW WATER LEVEL
- - - LITHOLOGIC CONTACT (DASHED WHERE INFERRED)
- ▨ SCREENED INTERVAL
- ▬ BOTTOM OF BORING
- ▨ DISTURBED TRENCH MATERIAL
- 1929 FILL MATERIAL
- BEACH DEPOSITS
- TRANSITIONAL SILT BED
- WHIDBEY FORMATION
- MARSH DEPOSITS
- 2007/2008 FILL (GRAVEL)
- 2007/2008 FILL (SILT, SAND AND GRAVEL)

(35' SE)= OFFSET DISTANCE FROM CROSS SECTION PROFILE

NOTES:

1. WSDOT STORMWATER LINE LOCATION IS APPROXIMATE AND DRAWN TO A NON EXAGGERATED SCALE FOR CLARITY.
2. HORIZONTAL DATUM: WASHINGTON STATE COORDINATE SYSTEM NORTH ZONE (NAD 83/98).
 VERTICAL DATUM: N.A.V.D. 88
 UNITS: U.S. SURVEY FEET
 HORIZONTAL AND VERTICAL CONTROL ESTABLISHED BY GPS VIA VERTICAL REFERENCE STATION NETWORK (VRSN).

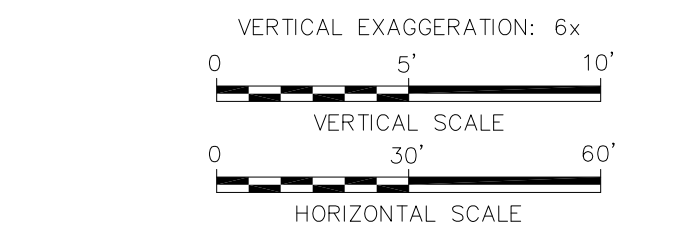

CHEVRON ENVIRONMENTAL MANAGEMENT COMPANY
 FORMER UNOCAL BULK FUEL TERMINAL
 EDMONDS, WASHINGTON
INTERIM ACTION WORK PLAN

**SOUTHEAST LOWER YARD
 GEOLOGIC CROSS SECTION C-C'**

ARCADIS | **FIGURE 2-7**

CITY: PHOENIX, AZ DIV/GROUP: ENVCAD DB: A. REYES, T. HUTCHINS-WASS, J. HARRIS
 C:\Users\jharris\Desktop\ENVCAD\RETURN\TO\PHOENIX_AZ\B0045362\0006\0002\IAV\DWG\B0045362_V02-8.dwg LAYOUT: 2-8_SAVED: 2/9/2015 2:39 PM ACADVER: 18.1S (LMS TECH) PAGES: 18 PAGES: 18 PLOT: PLTHALF-CTB PLOTTED: 2/10/2015 2:49 PM BY: HARRIS, JESSICA
 XREFS: IMAGES: PROJECTNAME: --

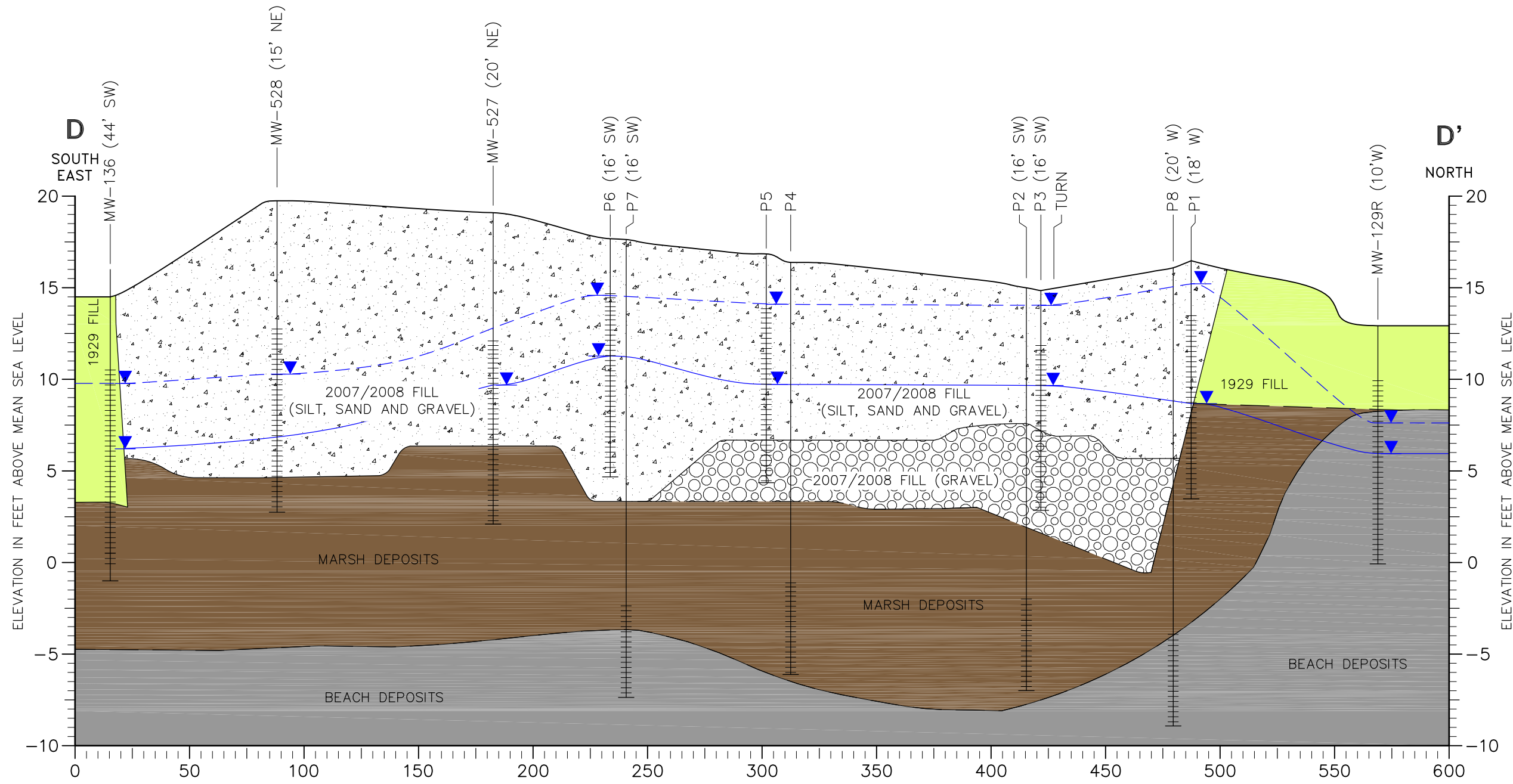

- LEGEND:**
- MW-136 WELL OR BORING ID
 - GROUND SURFACE
 - HISTORICAL HIGH WATER LEVEL
 - HISTORICAL LOW WATER LEVEL
 - LITHOLOGIC CONTACT (DASHED WHERE INFERRED)
 - SCREENED INTERVAL
 - BOTTOM OF BORING

- 1929 FILL MATERIAL
 - BEACH DEPOSITS
 - TRANSITIONAL SILT BED
 - WHIDBEY FORMATION
 - MARSH DEPOSITS
 - 2007/2008 FILL (GRAVEL)
 - 2007/2008 FILL (SILT, SAND AND GRAVEL)
- (20' W)= OFFSET DISTANCE FROM CROSS SECTION PROFILE

- NOTES:**
- CROSS SECTION DEPICTS SOIL CHARACTERISTICS OF EXCAVATION SIDE WALLS. EXCAVATIONS REACHED TOTAL DEPTHS OF 15 FT. BGS. (<0 FEET AMSL).
 - HORIZONTAL DATUM: WASHINGTON STATE COORDINATE SYSTEM NORTH ZONE (NAD 83/98). VERTICAL DATUM: N.A.V.D. 88. UNITS: U.S. SURVEY FEET. HORIZONTAL AND VERTICAL CONTROL ESTABLISHED BY GPS VIA VERTICAL REFERENCE STATION NETWORK (VRSN).

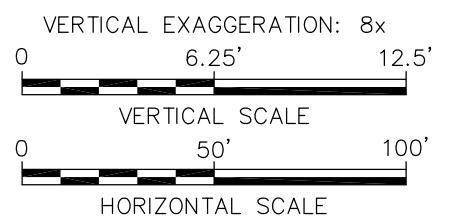

CHEVRON ENVIRONMENTAL MANAGEMENT COMPANY
 FORMER UNOCAL BULK FUEL TERMINAL
 EDMONDS, WASHINGTON
INTERIM ACTION WORK PLAN

**SOUTHEAST LOWER YARD
 GEOLOGIC CROSS SECTION D-D'**

FIGURE
2-8

CITY: EMV, CA DIV/GROUP: ENV/CAD DB: ASR PM: TME TR: LVR ON=OFF=REF* (FRZ)
 G:\ENV\CAD\Emeryville\ACT\B045362000500003\JAWP\DWG\B045362 802-9.dwg LAYOUT: 29 SAVED: 10/28/2014 11:16 AM ACADVER: 18.1S (LMS TECH) PAGESETUP: -- PLOTSTYLETABLE: PLTHALF-CTB PLOTTED: 10/30/2014 11:52 AM BY: REYES, ALEC
 XREFS: 45362X02 45362X03
 IMAGES: PROJECTNAME:

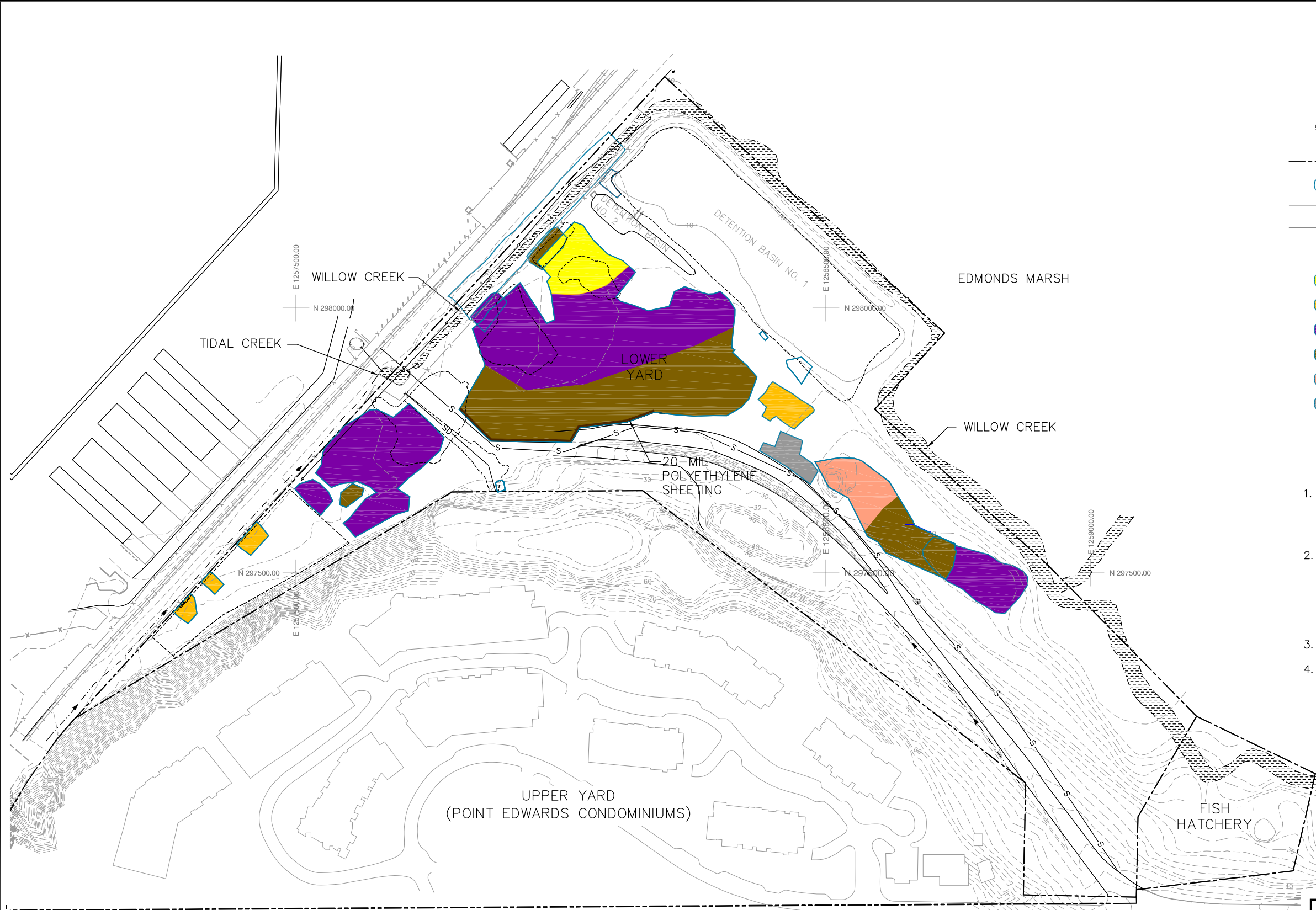

LEGEND:

- 2001 AND 2003 SOIL EXCAVATIONS BELOW GROUNDWATER TABLE
- PROPERTY BOUNDARY
- 2007/2008 EXCAVATION BOUNDARIES
- WSDOT STORMWATER LINE
- POINT EDWARDS STORM DRAIN LINE

TOP OF GRAVEL BACKFILL ELEVATION:

- 2 - 3 FT AMSL
- 4 - 5 FT AMSL
- 5 - 6 FT AMSL
- 6 - 7 FT AMSL
- 7 - 8 FT AMSL
- 9 - 11 FT AMSL

- NOTES:**
1. 20-MIL POLYETHYLENE SHEETING INSTALLED UPON COMPLETION OF PHASE I EXCAVATION. SHEETING REACHES TO APPROXIMATELY 7.5 FEET ABOVE MEAN SEA LEVEL.
 2. HORIZONTAL DATUM: WASHINGTON STATE COORDINATE SYSTEM NORTH ZONE (NAD 83/98).
 VERTICAL DATUM: N.A.V.D. 88
 UNITS: U.S. SURVEY FEET
 HORIZONTAL AND VERTICAL CONTROL ESTABLISHED BY GPS VIA VERTICAL REFERENCE STATION NETWORK (VRSN).
 3. FT AMSL = FEET ABOVE MEAN SEA LEVEL.
 4. SOUTHEAST PORTION OF WSDOT STORMWATER LINE HAS NOT BEEN SURVEYED.

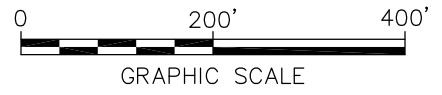

CHEVRON ENVIRONMENTAL MANAGEMENT COMPANY
 FORMER UNOCAL BULK FUEL TERMINAL
 EDMONDS, WASHINGTON
INTERIM ACTION WORK PLAN

TOP OF 2008 GRAVEL BACKFILL ELEVATIONS

FIGURE
2-9

CITY: EMV, CA DIV/GROUP: ENV/CAD DB: ASR PM: TME TR: LVR: ON=OFF=REF* (FRZ)
 G:\ENV\CAD\emeryville\ACT\B045362\005\0003\MAP\DWG\B045362_B02-10.dwg LAYOUT: 2-10 SAVED: 10/28/2014 11:19 AM ACADVER: 18.1S (LMS TECH) PAGES: 18 PLOTTED: 10/30/2014 11:53 AM BY: REYES, ALEC
 XREFS: 45362X02
 IMAGES: PROJECTNAME:



LEGEND:

- 2001 AND 2003 SOIL EXCAVATIONS BELOW GROUNDWATER TABLE
- LOWER YARD PROPERTY BOUNDARY
- 2007/2008 EXCAVATION BOUNDARIES
- WSDOT STORMWATER LINE
- POINT EDWARDS STORM DRAIN LINE

BOTTOM OF GRAVEL BACKFILL ELEVATION:

- 8 - 9 FT AMSL
- 6 - 4 FT AMSL
- 4 - 2 FT AMSL
- 2 - 0 FT AMSL
- 0 TO -2 FT AMSL

NOTES:

1. 20-MIL POLYETHYLENE SHEETING INSTALLED UPON COMPLETION OF PHASE I EXCAVATION. SHEETING REACHES TO APPROXIMATELY 7.5 FEET ABOVE MEAN SEA LEVEL.
2. HORIZONTAL DATUM: WASHINGTON STATE COORDINATE SYSTEM NORTH ZONE (NAD 83/98).
 VERTICAL DATUM: N.A.V.D. 88
 UNITS: U.S. SURVEY FEET
 HORIZONTAL AND VERTICAL CONTROL ESTABLISHED BY GPS VIA VERTICAL REFERENCE STATION NETWORK (VRSN).
3. FT AMSL = FEET ABOVE MEAN SEA LEVEL.
4. SOUTHEAST PORTION OF WSDOT STORMWATER LINE HAS NOT BEEN SURVEYED.

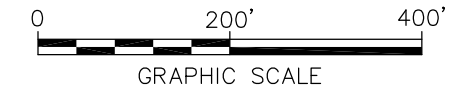

CHEVRON ENVIRONMENTAL MANAGEMENT COMPANY
 FORMER UNOCAL BULK FUEL TERMINAL
 EDMONDS, WASHINGTON
INTERIM ACTION WORK PLAN

BOTTOM OF 2008 GRAVEL BACKFILL ELEVATIONS

ARCADIS

FIGURE
2-10

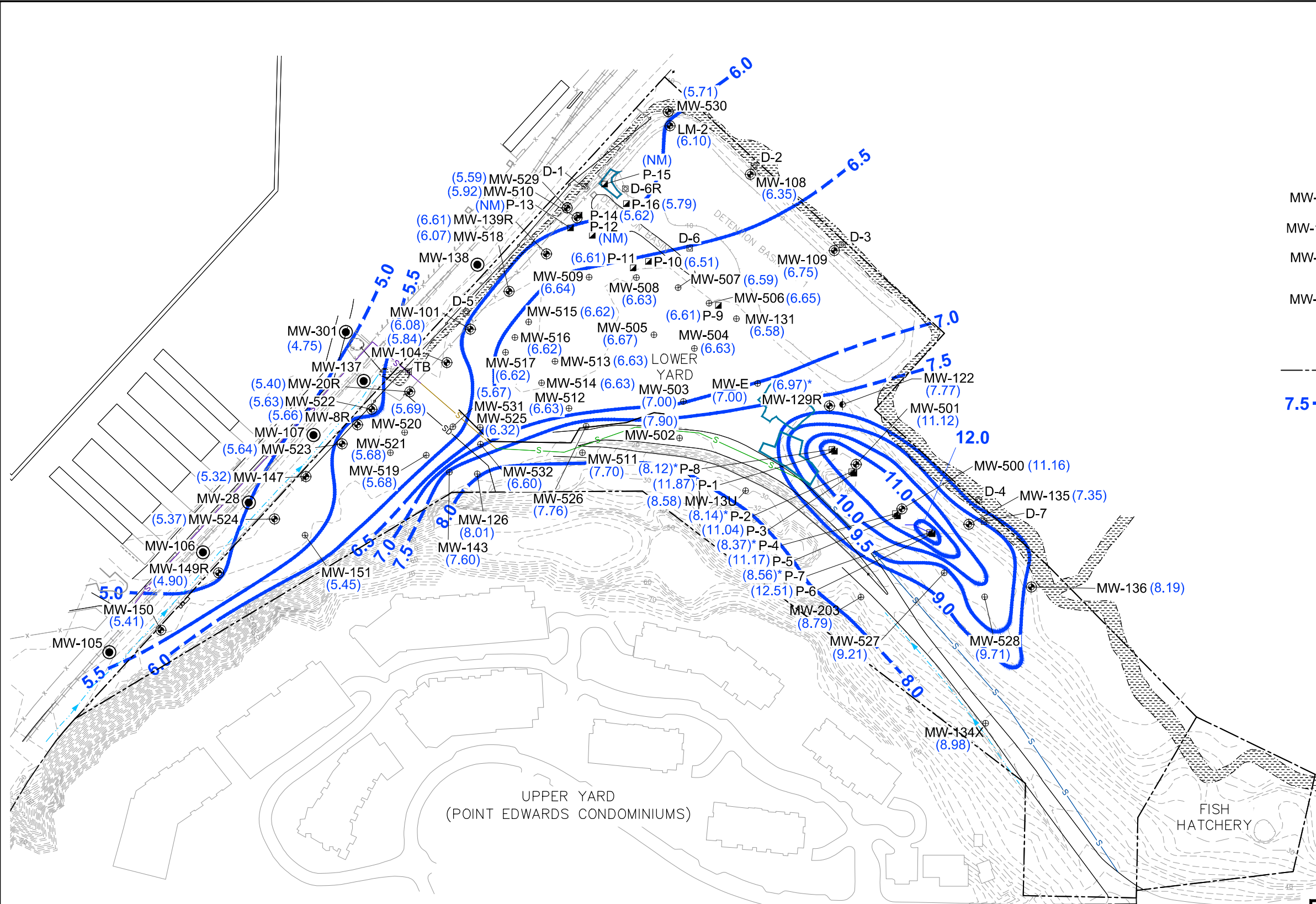

- MW-203 ⊕ INTERIOR MONITORING WELL LOCATION AND DESIGNATION
- MW-105 ● BNSF MONITORING WELL LOCATION
- MW-122 † DEEP MONITORING WELL LOCATION AND DESIGNATION
- MW-109 ⊕ PERIMETER MONITORING WELL LOCATION
- P-11 ▣ PIEZOMETER
- D-1 ⊠ STAFF GAUGE
- PROPERTY BOUNDARY
- 7.5 ——— GROUNDWATER ELEVATION CONTOUR (DASHED WHERE INFERRED)
- (12.51) GROUNDWATER ELEVATION
- (8.24)* GROUNDWATER ELEVATION NOT USED IN CONTOURING
- (NM) NOT MEASURED

NOTES:

1. 20-MIL POLYETHYLENE SHEETING INSTALLED UPON COMPLETION OF PHASE I EXCAVATION. SHEETING REACHES TO APPROXIMATELY 7.5 FEET ABOVE MEAN SEA LEVEL.
2. HORIZONTAL DATUM: WASHINGTON STATE COORDINATE SYSTEM NORTH ZONE (NAD 83/98). VERTICAL DATUM: N.A.V.D. 88. UNITS: U.S. SURVEY FEET. HORIZONTAL AND VERTICAL CONTROL ESTABLISHED BY GPS VIA VERTICAL REFERENCE STATION NETWORK (VRSN).
3. SOUTHEAST PORTION OF WSDOT STORM DRAIN LINE HAS NOT BEEN SURVEYED.

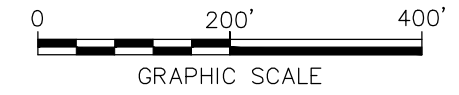

CHEVRON ENVIRONMENTAL MANAGEMENT COMPANY
 FORMER UNOCAL BULK FUEL TERMINAL
 EDMONDS, WASHINGTON
INTERIM ACTION WORK PLAN

SECOND QUARTER 2014 GROUNDWATER ELEVATIONS AND CONTOURS- JUNE 16, 2014



PROJECT NAME: _____
 IMAGES: _____
 XREFS: 45362x02, 45362x03

CITY: EMV, CA DIV/GROUP: ENV/CAD DB: ASR PM: TME TR: LVR: ON=OFF=REF* (FRZ)
 G:\ENV\CAD\Emeryville\ACT\B04536200500003\MAP\DWG\B045362 B02-12.dwg LAYOUT: 2-12 SAVED: 10/28/2014 11:25 AM ACADVER: 18.1S (LMS TECH) PAGES: 10/30/2014 11:54 AM BY: REYES, ALEC
 XREFS: 45362X02 45362X03
 IMAGES: PROJECTNAME:

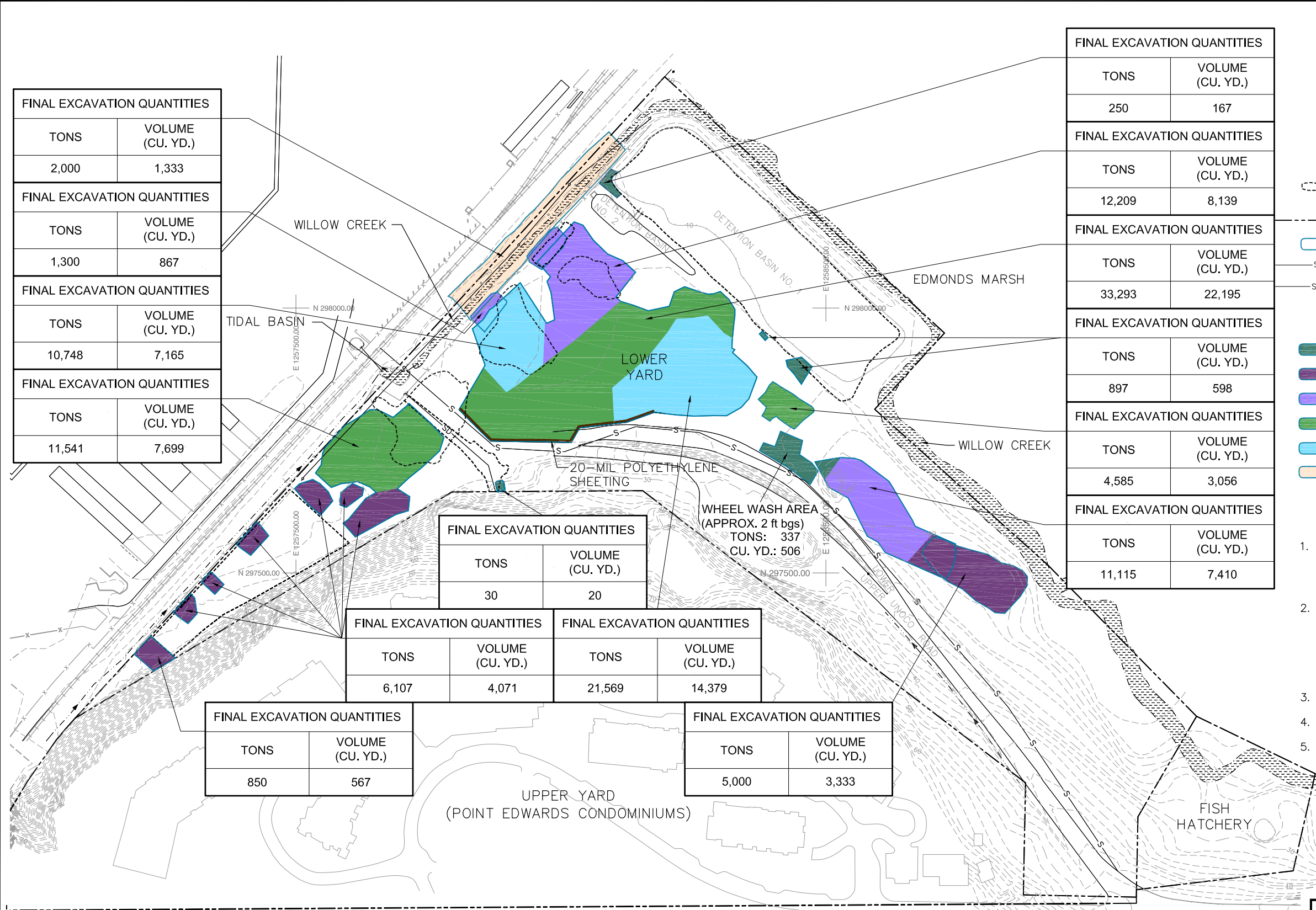

FINAL EXCAVATION QUANTITIES	
TONS	VOLUME (CU. YD.)
2,000	1,333

FINAL EXCAVATION QUANTITIES	
TONS	VOLUME (CU. YD.)
1,300	867

FINAL EXCAVATION QUANTITIES	
TONS	VOLUME (CU. YD.)
10,748	7,165

FINAL EXCAVATION QUANTITIES	
TONS	VOLUME (CU. YD.)
11,541	7,699

FINAL EXCAVATION QUANTITIES	
TONS	VOLUME (CU. YD.)
30	20

FINAL EXCAVATION QUANTITIES	
TONS	VOLUME (CU. YD.)
6,107	4,071

FINAL EXCAVATION QUANTITIES	
TONS	VOLUME (CU. YD.)
21,569	14,379

FINAL EXCAVATION QUANTITIES	
TONS	VOLUME (CU. YD.)
850	567

FINAL EXCAVATION QUANTITIES	
TONS	VOLUME (CU. YD.)
5,000	3,333

FINAL EXCAVATION QUANTITIES	
TONS	VOLUME (CU. YD.)
250	167

FINAL EXCAVATION QUANTITIES	
TONS	VOLUME (CU. YD.)
12,209	8,139

FINAL EXCAVATION QUANTITIES	
TONS	VOLUME (CU. YD.)
33,293	22,195

FINAL EXCAVATION QUANTITIES	
TONS	VOLUME (CU. YD.)
897	598

FINAL EXCAVATION QUANTITIES	
TONS	VOLUME (CU. YD.)
4,585	3,056

FINAL EXCAVATION QUANTITIES	
TONS	VOLUME (CU. YD.)
11,115	7,410

N

LEGEND:

- 2001 AND 2003 SOIL EXCAVATIONS BELOW GROUNDWATER TABLE
- PROPERTY BOUNDARY
- 2007/2008 EXCAVATION BOUNDARIES
- WSDOT STORMWATER LINE
- POINT EDWARDS STORM DRAIN LINE

BOTTOM OF GRAVEL BACKFILL ELEVATION:

- 8 - 9 FT AMSL
- 6 - 4 FT AMSL
- 4 - 2 FT AMSL
- 2 - 0 FT AMSL
- 0 TO -2 FT AMSL
- WILLOW CREEK SEDIMENT REMOVAL AREA (1 FOOT SCRAPE)

- NOTES:**
- 20-MIL POLYETHYLENE SHEETING INSTALLED UPON COMPLETION OF PHASE I EXCAVATION. SHEETING REACHES TO APPROXIMATELY 7.5 FEET ABOVE MEAN SEA LEVEL.
 - HORIZONTAL DATUM: WASHINGTON STATE COORDINATE SYSTEM NORTH ZONE (NAD 83/98). VERTICAL DATUM: N.A.V.D. 88. UNITS: U.S. SURVEY FEET. HORIZONTAL AND VERTICAL CONTROL ESTABLISHED BY GPS VIA VERTICAL REFERENCE STATION NETWORK (VRSN).
 - CU. YD. = CUBIC YARDS
 - FT AMSL = FEET ABOVE MEAN SEA LEVEL.
 - SOUTHEAST PORTION OF WSDOT STORMWATER LINE HAS NOT BEEN SURVEYED.



CHEVRON ENVIRONMENTAL MANAGEMENT COMPANY
 FORMER UNOCAL BULK FUEL TERMINAL
 EDMONDS, WASHINGTON
INTERIM ACTION WORK PLAN

**2007/2008 INTERIM ACTION FINAL
 EXCAVATION LIMITS AND VOLUMES**

ARCADIS

FIGURE
2-12

CITY: EMV, CA DIV/GROUP: ENVCAD, DB: ASR, PM: TWE, TR: LVR, ON: OFF-REF, (FRZ)
 C:\Users\hutchins\My Documents\45962X02\B02-13.dwg LAYOUT: 2-13, SAVED: 2/10/2015 2:34 PM, ACADVER: 18.1, S (LMS TECH), PAGES: 18, PLOTTED: 2/10/2015 2:35 PM, BY: HUTCHINS-WASS, TABITHA

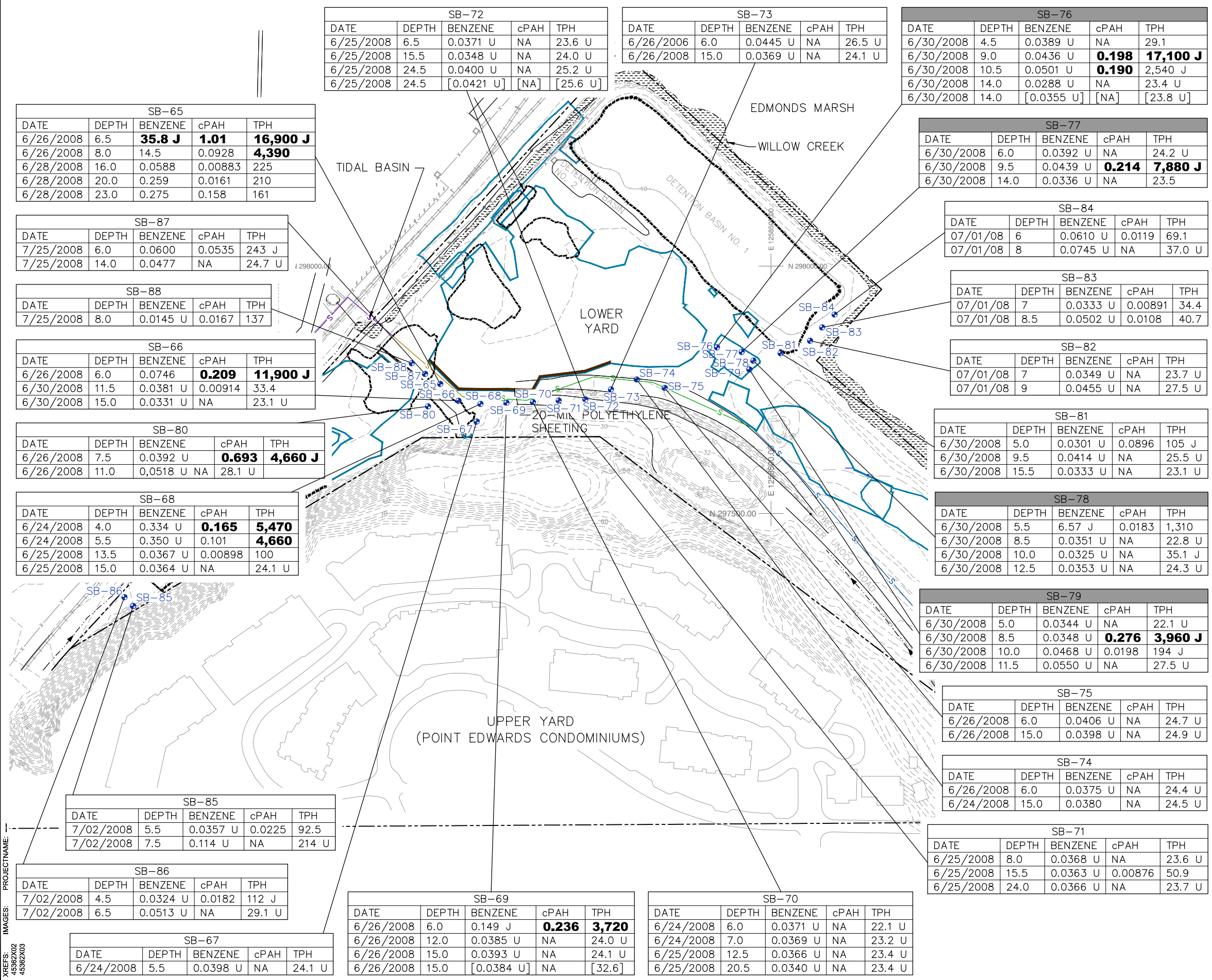

LEGEND:

- 2001 AND 2003 SOIL EXCAVATIONS BELOW GROUNDWATER TABLE
- - - - - PROPERTY BOUNDARY
- 2007/2008 EXCAVATION BOUNDARIES
- S- WSDOT STORMWATER LINE
- SD- POINT EDWARDS STORM DRAIN LINE
- SOIL BORING/HAND AUGER LOCATION
- cPAH CARCINOGENIC POLYNUCLEAR AROMATIC HYDROCARBONS, ADJUSTED FOR TOXICITY
- CUL CLEANUP LEVEL
- REL REMEDIATION LEVEL
- TPH TOTAL PETROLEUM HYDROCARBONS
- [] VALUES SHOWN IN BRACKETS INDICATE DUPLICATE RESULTS
- NA INDICATES ANALYSIS NOT CONDUCTED
- U THE COMPOUND WAS ANALYZED FOR BUT NOT DETECTED. THE ASSOCIATED VALUE IS THE COMPOUND QUANTITATION LIMIT
- J INDICATES AN ESTIMATED VALUE

ALL DATA REPORTED AS MILLIGRAMS PER KILOGRAMS (mg/kg)

SAMPLE DEPTHS REPORTED AS FEET BELOW GROUND SURFACE (ft bgs)

BOLDED DATA INDICATES CONCENTRATIONS GREATER THAN APPLICABLE SITE CULs/RELS

SAMPLE WAS COLLECTED WITHIN THE 2007/2008 EXCAVATION BOUNDARIES

- NOTES:**
- 20-MIL POLYETHYLENE SHEETING INSTALLED UPON COMPLETION OF PHASE I OF THE 2007/2008 EXCAVATION. SHEETING REACHES TO APPROXIMATELY 7.5 FEET ABOVE MEAN SEA LEVEL.
 - HORIZONTAL DATUM: WASHINGTON STATE COORDINATE SYSTEM NORTH ZONE (NAD 83/98). VERTICAL DATUM: N.A.V.D. 88. UNITS: U.S. SURVEY FEET. HORIZONTAL AND VERTICAL CONTROL ESTABLISHED BY GPS VIA VERTICAL REFERENCE STATION NETWORK (VRSN).
 - SOUTHEAST PORTION OF WSDOT STORMWATER LINE HAS NOT BEEN SURVEYED.

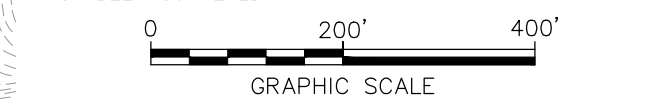

CHEVRON ENVIRONMENTAL MANAGEMENT COMPANY
 FORMER UNOCO BULK FUEL TERMINAL
 EDMONDS, WASHINGTON
INTERIM ACTION WORK PLAN

2008 SITE INVESTIGATION SAMPLE LOCATIONS AND ANALYTICAL RESULTS

CITY: EMV, CA DIV/GROUP: ENVCAD, DB: ASR, PM: TWE, TR: LVR, ON: OFF=REF, (FRZ)
 C:\Users\hutchins\workspace\Deskop\NAV\DWG\B02-14.dwg LAYOUT: 2-14, SAVED: 2/9/2015 1:42 PM, ACADVER: 18.15 (LMS TECH) PAGES: 1-14, PLOT: 2/9/2015 1:43 PM, BY: HUTCHINS-WASS, TABLITHA

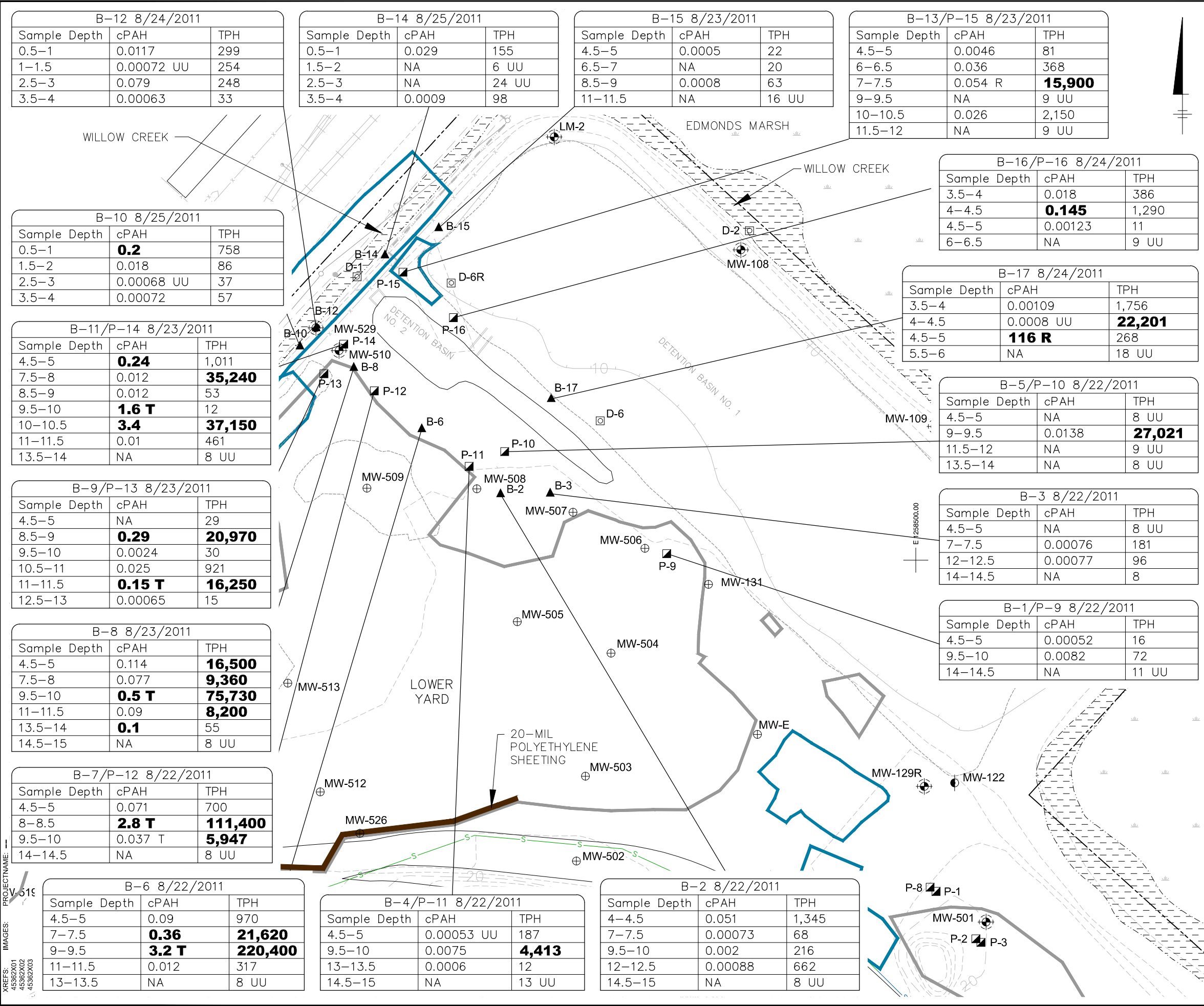

B-12 8/24/2011		
Sample Depth	cPAH	TPH
0.5-1	0.0117	299
1-1.5	0.00072 UU	254
2.5-3	0.079	248
3.5-4	0.00063	33

B-14 8/25/2011		
Sample Depth	cPAH	TPH
0.5-1	0.029	155
1.5-2	NA	6 UU
2.5-3	NA	24 UU
3.5-4	0.0009	98

B-15 8/23/2011		
Sample Depth	cPAH	TPH
4.5-5	0.0005	22
6.5-7	NA	20
8.5-9	0.0008	63
11-11.5	NA	16 UU

B-13/P-15 8/23/2011		
Sample Depth	cPAH	TPH
4.5-5	0.0046	81
6-6.5	0.036	368
7-7.5	0.054 R	15,900
9-9.5	NA	9 UU
10-10.5	0.026	2,150
11.5-12	NA	9 UU

B-10 8/25/2011		
Sample Depth	cPAH	TPH
0.5-1	0.2	758
1.5-2	0.018	86
2.5-3	0.00068 UU	37
3.5-4	0.00072	57

B-11/P-14 8/23/2011		
Sample Depth	cPAH	TPH
4.5-5	0.24	1,011
7.5-8	0.012	35,240
8.5-9	0.012	53
9.5-10	1.6 T	12
10-10.5	3.4	37,150
11-11.5	0.01	461
13.5-14	NA	8 UU

B-9/P-13 8/23/2011		
Sample Depth	cPAH	TPH
4.5-5	NA	29
8.5-9	0.29	20,970
9.5-10	0.0024	30
10.5-11	0.025	921
11-11.5	0.15 T	16,250
12.5-13	0.00065	15

B-8 8/23/2011		
Sample Depth	cPAH	TPH
4.5-5	0.114	16,500
7.5-8	0.077	9,360
9.5-10	0.5 T	75,730
11-11.5	0.09	8,200
13.5-14	0.1	55
14.5-15	NA	8 UU

B-7/P-12 8/22/2011		
Sample Depth	cPAH	TPH
4.5-5	0.071	700
8-8.5	2.8 T	111,400
9.5-10	0.037 T	5,947
14-14.5	NA	8 UU

B-6 8/22/2011		
Sample Depth	cPAH	TPH
4.5-5	0.09	970
7-7.5	0.36	21,620
9-9.5	3.2 T	220,400
11-11.5	0.012	317
13-13.5	NA	8 UU

B-4/P-11 8/22/2011		
Sample Depth	cPAH	TPH
4.5-5	0.00053 UU	187
9.5-10	0.0075	4,413
13-13.5	0.0006	12
14.5-15	NA	13 UU

B-2 8/22/2011		
Sample Depth	cPAH	TPH
4-4.5	0.051	1,345
7-7.5	0.00073	68
9.5-10	0.002	216
12-12.5	0.00088	662
14.5-15	NA	8 UU

B-16/P-16 8/24/2011		
Sample Depth	cPAH	TPH
3.5-4	0.018	386
4-4.5	0.145	1,290
4.5-5	0.00123	11
6-6.5	NA	9 UU

B-17 8/24/2011		
Sample Depth	cPAH	TPH
3.5-4	0.00109	1,756
4-4.5	0.0008 UU	22,201
4.5-5	116 R	268
5.5-6	NA	18 UU

B-5/P-10 8/22/2011		
Sample Depth	cPAH	TPH
4.5-5	NA	8 UU
9-9.5	0.0138	27,021
11.5-12	NA	9 UU
13.5-14	NA	8 UU

B-3 8/22/2011		
Sample Depth	cPAH	TPH
4.5-5	NA	8 UU
7-7.5	0.00076	181
12-12.5	0.00077	96
14-14.5	NA	8

B-1/P-9 8/22/2011		
Sample Depth	cPAH	TPH
4.5-5	0.00052	16
9.5-10	0.0082	72
14-14.5	NA	11 UU

- LEGEND:**
- MW-203 ⊕ INTERIOR MONITORING WELL LOCATION AND DESIGNATION
 - MW-122 ⊕ DEEP MONITORING WELL LOCATION AND DESIGNATION
 - MW-109 ⊕ PERIMETER MONITORING WELL LOCATION
 - P-11 ▣ PIEZOMETER
 - D-1 ⊕ STAFF GAUGE
 - 2001 AND 2003 SOIL EXCAVATIONS BELOW GROUNDWATER TABLE
 - PROPERTY BOUNDARY
 - 2007/2008 EXCAVATION BOUNDARIES
 - S WSDOT STORMWATER LINE
 - SD POINT EDWARDS STORM DRAIN LINE

LOCATION ID SAMPLE DATE		
Sample Depth	cPAH	TPH
Depth in feet below ground surface	Total carcinogenic polynuclear aromatic hydrocarbons, adjusted for toxicity (mg/kg)	Total petroleum hydrocarbons (mg/kg)

- UU - THE CONSTITUENTS MAKING UP THE TOTAL ARE ALL NON-DETECTS
- T - REPORTING LIMITS WERE RAISED DUE TO INTERFERENCE FROM THE SAMPLE MATRIX
- R - THE GC/MS SEMIVOLATILE INTERNAL STANDARD PEAK AREAS WERE OUTSIDE OF THE QC LIMITS FOR BOTH THE INITIAL INJECTION AND THE RE-INJECTION
- NA - ANALYSIS NOT CONDUCTED
- mg/kg - MILLIGRAMS PER KILOGRAM
- BOLD CONCENTRATIONS REPRESENT EXCEEDANCE OF SITE CLEAN-UP LEVELS

- NOTES:**
- 20-MIL POLYETHYLENE SHEETING INSTALLED UPON COMPLETION OF PHASE I EXCAVATION. SHEETING REACHES TO APPROXIMATELY 7.5 FEET ABOVE MEAN SEA LEVEL.
 - HORIZONTAL DATUM: WASHINGTON STATE COORDINATE SYSTEM NORTH ZONE (NAD 83/98). VERTICAL DATUM: N.A.V.D. 88. UNITS: U.S. SURVEY FEET. HORIZONTAL AND VERTICAL CONTROL ESTABLISHED BY GPS VIA VERTICAL REFERENCE STATION NETWORK (VRSN).
 - SOUTHEAST PORTION OF WSDOT STORMWATER LINE HAS NOT BEEN SURVEYED.

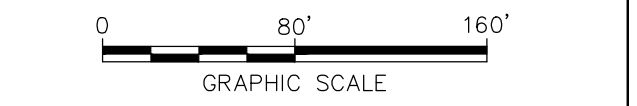

CHEVRON ENVIRONMENTAL MANAGEMENT COMPANY
 FORMER UNOCAL BULK FUEL TERMINAL
 EDMONDS, WASHINGTON
INTERIM ACTION WORK PLAN
2011 SITE INVESTIGATION SOIL SAMPLE LOCATIONS AND ANALYTICAL RESULTS

MW-525				
DATE	DEPTH	BENZENE	cPAH	TPH
6/14/2012	4'	3.5 W	NA	1,277
6/14/2012	6'	34 T	0.29	17,850
6/18/2012	10.5'	0.014 [0.10]	NA [NA]	NA
6/18/2012	12.5'	1.7	NA	683

MW-526				
DATE	DEPTH	BENZENE	cPAH	TPH
6/14/2012	4'	0.019 UT	NA	34
6/18/2012	12.5'	0.0061 U	NA	8 UU

MW-531				
DATE	DEPTH	BENZENE	cPAH	TPH
6/14/2012	6'	0.0084	NA	310
6/18/2012	12'	0.13	NA	48

MW-528				
DATE	DEPTH	BENZENE	cPAH	TPH
6/14/2012	8'	0.15	NA	27
6/22/2012	15'	0.025 UW	NA	440
6/22/2012	17'	0.078	NA	11 UU

MW-532				
DATE	DEPTH	BENZENE	cPAH	TPH
6/18/2012	6'	0.084 U	NA	1,499
6/18/2012	7'	0.16 UT	0.04	10,540
6/18/2012	10'	0.0079 U	NA	11 UU
6/18/2012	13.5'	0.0066 UU	NA	1,681

MW-527				
DATE	DEPTH	BENZENE	cPAH	TPH
6/14/2012	8'	0.02	NA	352
6/22/2012	9'	0.053 UW	NA	636
6/22/2012	12'	0.11 UW	NA	716
6/22/2012	13.5'	0.11 UW	NA	1,621
6/22/2012	17'	0.068 UW [0.070 UW]	NA [NA]	15 UU [15 UU]

LEGEND:

- MW-203 ⊕ INTERIOR MONITORING WELL LOCATION AND DESIGNATION
- MW-105 ⊙ BNSF MONITORING WELL LOCATION
- MW-122 ⊕ DEEP MONITORING WELL LOCATION AND DESIGNATION
- MW-109 ⊕ PERIMETER MONITORING WELL LOCATION
- 2001 AND 2003 SOIL EXCAVATIONS BELOW GROUNDWATER TABLE
- PROPERTY BOUNDARY
- 2007/2008 EXCAVATION BOUNDARIES
- S- WSDOT STORMWATER LINE
- SD- POINT EDWARDS STORM DRAIN LINE
- cPAH CARCINOGENIC POLYNUCLEAR AROMATIC HYDROCARBONS, ADJUSTED FOR TOXICITY
- CUL CLEANUP LEVEL
- REL REMEDIATION LEVEL
- TPH TOTAL PETROLEUM HYDROCARBONS
- [] VALUES SHOWN IN BRACKETS INDICATE DUPLICATE RESULTS
- NA INDICATES ANALYSIS NOT CONDUCTED
- U THE COMPOUND WAS ANALYZED FOR BUT NOT DETECTED. THE ASSOCIATED VALUE IS THE COMPOUND QUANTITATION LIMIT
- UU THE CONSTITUENTS MAKING UP THE TOTAL ARE ALL NON-DETECTS
- J INDICATES AN ESTIMATED VALUE
- W REPORTING LIMITS WERE RAISED DUE TO SAMPLE FOAMING
- T REPORTING LIMITS WERE RAISED DUE TO INTERFERENCE FROM THE SAMPLE MATRIX

ALL DATA REPORTED AS MILLIGRAMS PER KILOGRAMS (mg/kg)

SAMPLE DEPTHS REPORTED AS FEET BELOW GROUND SURFACE (ft bgs)

BOLDED DATA INDICATES CONCENTRATIONS GREATER THAN APPLICABLE SITE CULs/RELs

- NOTES:**
- 20-MIL POLYETHYLENE SHEETING INSTALLED UPON COMPLETION OF PHASE I EXCAVATION. SHEETING REACHES TO APPROXIMATELY 7.5 FEET ABOVE MEAN SEA LEVEL.
 - HORIZONTAL DATUM: WASHINGTON STATE COORDINATE SYSTEM NORTH ZONE (NAD 83/98).
 VERTICAL DATUM: N.A.V.D. 88
 UNITS: U.S. SURVEY FEET
 HORIZONTAL AND VERTICAL CONTROL ESTABLISHED BY GPS VIA VERTICAL REFERENCE STATION NETWORK (VRSN).
 - SOUTHEAST PORTION OF WSDOT STORMWATER LINE HAS NOT BEEN SURVEYED.

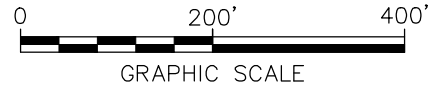

CHEVRON ENVIRONMENTAL MANAGEMENT COMPANY
 FORMER UNOCAL BULK FUEL TERMINAL
 EDMONDS, WASHINGTON
INTERIM ACTION WORK PLAN

2012 SOIL SAMPLE LOCATIONS AND ANALYTICAL RESULTS



CITY: EMV, CA DIV/GROUP: ENV/CAD DB: ASR PM: TME TR: LVR: ON=OFF=REF* (FRZ)
 G:\ENV\CAD\Energy\file\ACT\B04536200500003\MAP\DWG\B045362 802-16.dwg LAYOUT: 2-16 SAVED: 10/28/2014 12:52 PM ACADVER: 18.1S (LMS TECH) PAGES: 18 PAGES SETUP: PLTHALF-CTB PLOTTED: 10/30/2014 11:59 AM BY: REYES, ALEC
 XREFS: PROJECTNAME: IMAGES: 45362X02 45362X03

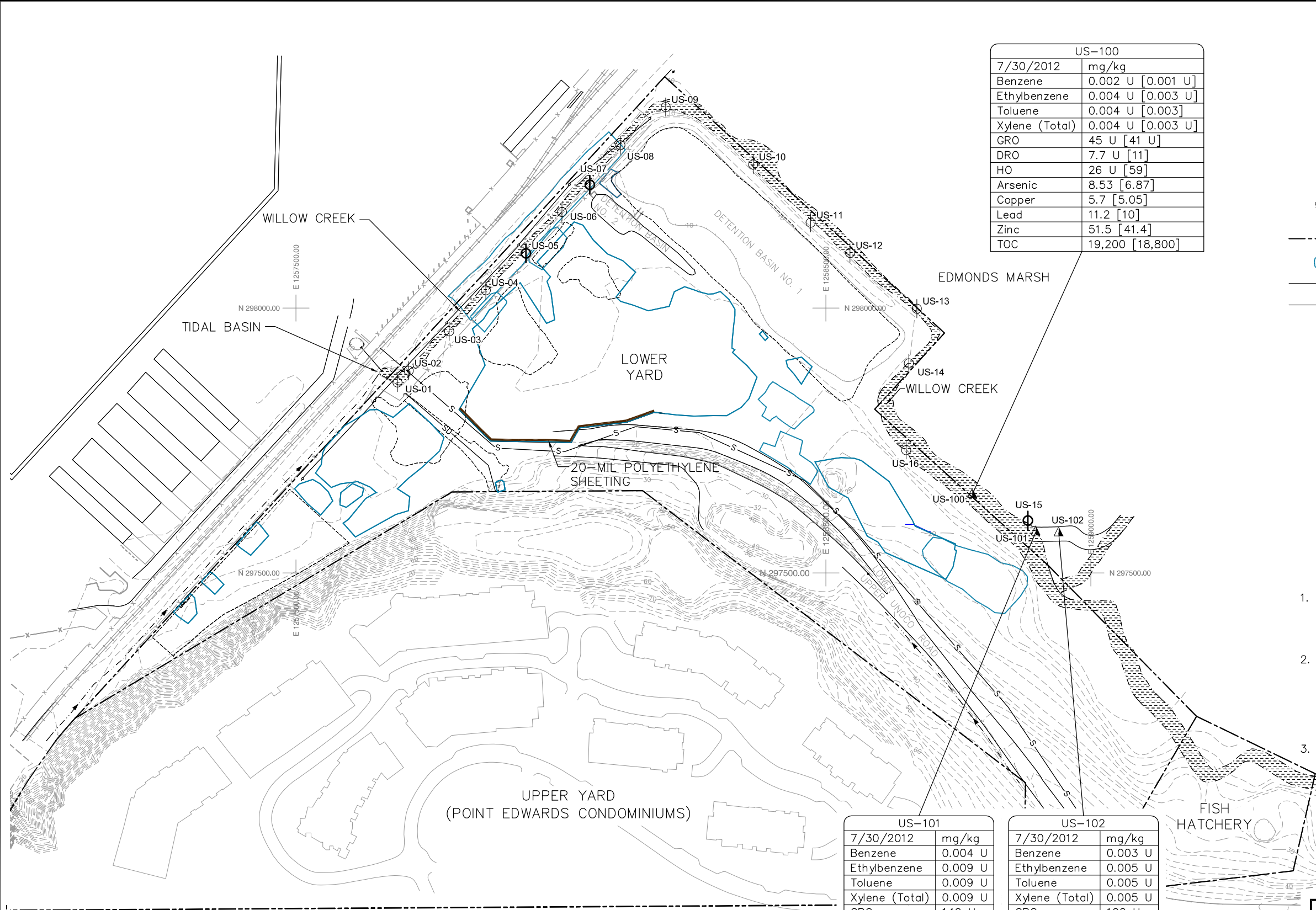

US-100	
7/30/2012	mg/kg
Benzene	0.002 U [0.001 U]
Ethylbenzene	0.004 U [0.003 U]
Toluene	0.004 U [0.003 U]
Xylene (Total)	0.004 U [0.003 U]
GRO	45 U [41 U]
DRO	7.7 U [11]
HO	26 U [59]
Arsenic	8.53 [6.87]
Copper	5.7 [5.05]
Lead	11.2 [10]
Zinc	51.5 [41.4]
TOC	19,200 [18,800]

- LEGEND:**
- 2001 AND 2003 SOIL EXCAVATIONS BELOW GROUNDWATER TABLE
 - PROPERTY BOUNDARY
 - 2007/2008 EXCAVATION BOUNDARIES
 - WSDOT STORMWATER LINE
 - POINT EDWARDS STORM DRAIN LINE
 - SEDIMENT SAMPLE LOCATIONS (2003)
 - SEDIMENT SAMPLE LOCATIONS (2012)
 - BOLDED SEDIMENT SAMPLE LOCATIONS INDICATE FAILED BIOASSAY TESTING IN 2003.
- GRO = Total petroleum hydrocarbons in the gasoline range
 DRO = Total petroleum hydrocarbons in the diesel range
 HO = Total petroleum hydrocarbons in the heavy oil range
 TOC = Total Organic Carbon
 U = Indicates the value was below the Method Detection Limit.
 [] = Duplicate results are shown in brackets

- NOTES:**
- 20-MIL POLYETHYLENE SHEETING INSTALLED UPON COMPLETION OF PHASE I EXCAVATION. SHEETING REACHES TO APPROXIMATELY 7.5 FEET ABOVE MEAN SEA LEVEL.
 - HORIZONTAL DATUM: WASHINGTON STATE COORDINATE SYSTEM NORTH ZONE (NAD 83/98). VERTICAL DATUM: N.A.V.D. 88 UNITS: U.S. SURVEY FEET HORIZONTAL AND VERTICAL CONTROL ESTABLISHED BY GPS VIA VERTICAL REFERENCE STATION NETWORK (VRSN).
 - SOUTHEAST PORTION OF WSDOT STORMWATER LINE HAS NOT BEEN SURVEYED.

US-101	
7/30/2012	mg/kg
Benzene	0.004 U
Ethylbenzene	0.009 U
Toluene	0.009 U
Xylene (Total)	0.009 U
GRO	140 U
DRO	29
HO	170
Arsenic	29.1
Copper	43.6
Lead	107
Zinc	319
TOC	64,700

US-102	
7/30/2012	mg/kg
Benzene	0.003 U
Ethylbenzene	0.005 U
Toluene	0.005 U
Xylene (Total)	0.005 U
GRO	100 U
DRO	17
HO	110
Arsenic	20.2
Copper	21.6
Lead	60.6
Zinc	144
TOC	65,200

CHEVRON ENVIRONMENTAL MANAGEMENT COMPANY
 FORMER UNOCO BULK FUEL TERMINAL
 EDMONDS, WASHINGTON
INTERIM ACTION WORK PLAN

**SEDIMENT SAMPLING LOCATIONS AND
 2012 ANALYTICAL RESULTS**

ARCADIS

FIGURE
2-16

CITY: EMV, CA, DIV: GROUP: ENV/ROAD, DB: ASR, PM: TIME, TR: LVR, ON: OFF, REF: FRZ, C:\Users\jessica\Desktop\ENV\ROAD\RETURN\TO\EMERYVILLE, CA\B0404562\0005\0003\1\WP\DWG\B0404562 B02-17.dwg, LAYOUT: 2-17, SAVER: 10/30/2014 11:00 AM, ACADVER: 18, IS (LIMS TECH), PAGES: 1, PLOT: 11/20/2014 7:47 PM, BY: HARRIS, JESSICA

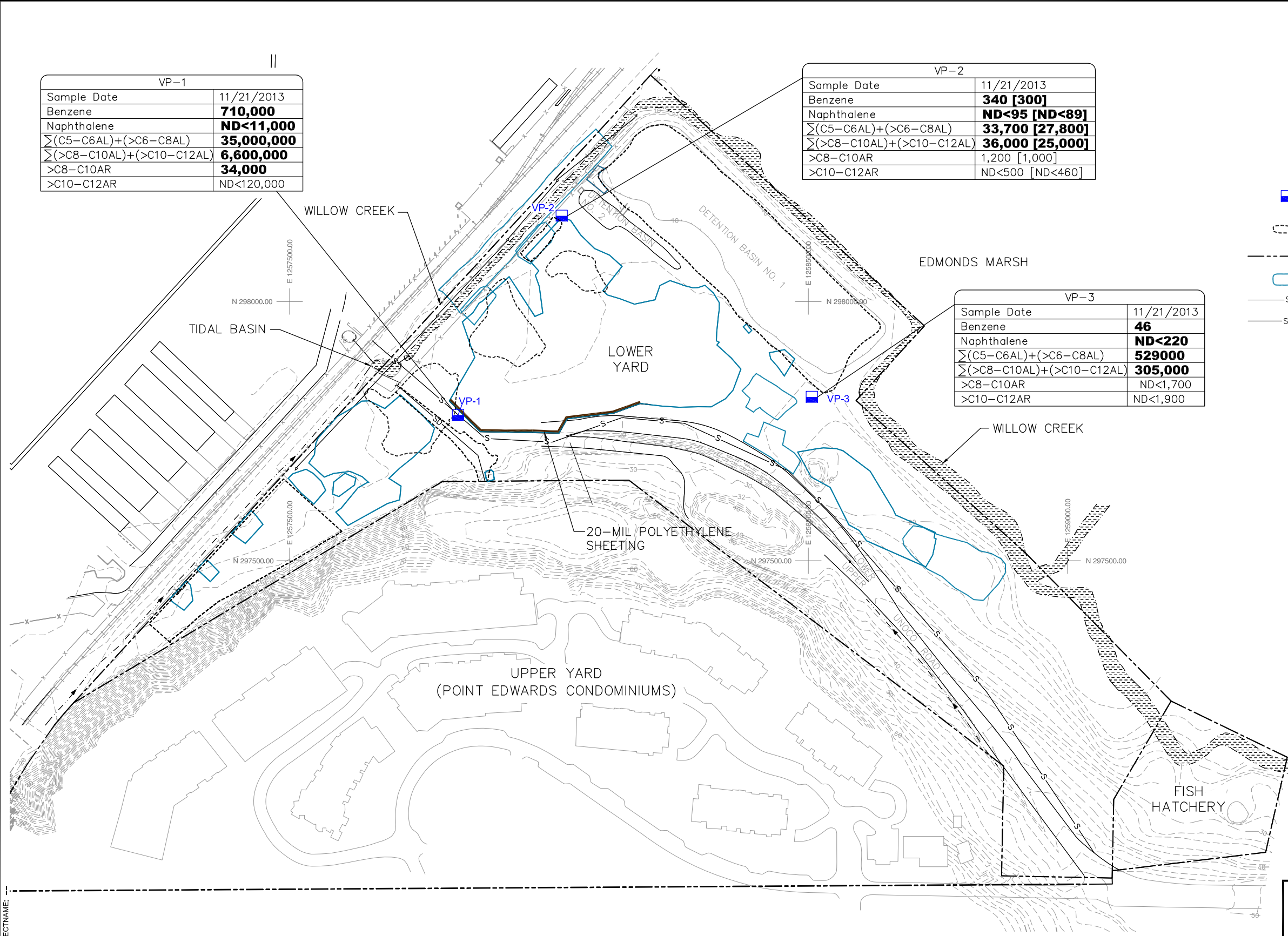

VP-1	
Sample Date	11/21/2013
Benzene	710,000
Naphthalene	ND<11,000
Σ(C5-C6AL)+(>C6-C8AL)	35,000,000
Σ(>C8-C10AL)+(>C10-C12AL)	6,600,000
>C8-C10AR	34,000
>C10-C12AR	ND<120,000

VP-2	
Sample Date	11/21/2013
Benzene	340 [300]
Naphthalene	ND<95 [ND<89]
Σ(C5-C6AL)+(>C6-C8AL)	33,700 [27,800]
Σ(>C8-C10AL)+(>C10-C12AL)	36,000 [25,000]
>C8-C10AR	1,200 [1,000]
>C10-C12AR	ND<500 [ND<460]

VP-3	
Sample Date	11/21/2013
Benzene	46
Naphthalene	ND<220
Σ(C5-C6AL)+(>C6-C8AL)	529,000
Σ(>C8-C10AL)+(>C10-C12AL)	305,000
>C8-C10AR	ND<1,700
>C10-C12AR	ND<1,900

LEGEND:

- SOIL VAPOR PROBE/SAMPLING LOCATION
- 2001 AND 2003 SOIL EXCAVATIONS BELOW GROUNDWATER TABLE
- PROPERTY BOUNDARY
- 2007/2008 EXCAVATION BOUNDARIES
- WSDOT STORMWATER LINE
- POINT EDWARDS STORM DRAIN LINE

AL = vapor phase hydrocarbon aliphatic carbon range
 AR = vapor phase hydrocarbon aromatic carbon range
 <ND = Non-detect, value listed is laboratory reporting limit.
 [] = Duplicate results are shown in brackets
 bgs = below ground surface

All results are in micrograms per cubic meter (µg/m³).
 All samples were collected from soil vapor probes installed at 5 feet bgs.
 Bolded cells indicate detected concentrations above the Ecology Method B Screening.
 Level for sample locations just beneath a building or less than 15 feet bgs.

NOTES:

1. 20-MIL POLYETHYLENE SHEETING INSTALLED UPON COMPLETION OF PHASE I EXCAVATION. SHEETING REACHES TO APPROXIMATELY 7.5 FEET ABOVE MEAN SEA LEVEL.
2. HORIZONTAL DATUM: WASHINGTON STATE COORDINATE SYSTEM NORTH ZONE (NAD 83/98). VERTICAL DATUM: N.A.V.D. 88. UNITS: U.S. SURVEY FEET. HORIZONTAL AND VERTICAL CONTROL ESTABLISHED BY GPS VIA VERTICAL REFERENCE STATION NETWORK (VRSN).
3. SOUTHEAST PORTION OF WSDOT STORMWATER LINE HAS NOT BEEN SURVEYED.

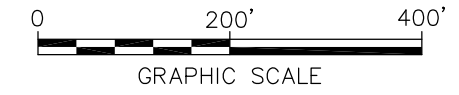

CHEVRON ENVIRONMENTAL MANAGEMENT COMPANY
 FORMER UNOCO BULK FUEL TERMINAL
 EDMONDS, WASHINGTON
INTERIM ACTION WORK PLAN

2013 SOIL VAPOR SAMPLE LOCATIONS AND ANALYTICAL RESULTS

FIGURE
2-17

CITY: EMV, CA DIV/GROUP: ENV/CAD DB: ASR PM: TME TR: LYR: ON=OFF=REF* (FRZ)
 G:\ENV\CAD\emery\hills\ACT\B04536200500003\MAP\DWG\B045362003-1.dwg LAYOUT: 3-1 SAVED: 10/17/2014 1:37 PM ACADVER: 18.1S (LMS TECH) PAGES: 18.1S (LMS TECH) PAGES: 18.1S (LMS TECH) PAGES: 18.1S (LMS TECH) PAGES: 18.1S (LMS TECH)
 XREFS: 45362X02 45362X03
 IMAGES: PROJECTNAME:



- LEGEND:**
- 2001 AND 2003 SOIL EXCAVATIONS BELOW GROUNDWATER TABLE
 - PROPERTY BOUNDARY
 - 2007/2008 EXCAVATION BOUNDARIES
 - WSDOT STORMWATER LINE
 - POINT EDWARDS STORM DRAIN LINE
 - >500 µg/L
 - >700 µg/L
 - >900 µg/L
 - LIGHT NONAQUEOUS PHASE LIQUID (LNAPL)

- NOTES:**
1. µg/L = MICROGRAMS PER LITER.
 2. TOTAL TPH CONCENTRATIONS BASED ON SEPTEMBER 2006 SAMPLING EVENT RESULTS.
 3. 20-MIL POLYETHYLENE SHEETING INSTALLED UPON COMPLETION OF PHASE I EXCAVATION. SHEETING REACHES TO APPROXIMATELY 7.5 FEET ABOVE MEAN SEA LEVEL.
 4. HORIZONTAL DATUM: WASHINGTON STATE COORDINATE SYSTEM NORTH ZONE (NAD 83/98). VERTICAL DATUM: N.A.V.D. 88. UNITS: U.S. SURVEY FEET. HORIZONTAL AND VERTICAL CONTROL ESTABLISHED BY GPS VIA VERTICAL REFERENCE STATION NETWORK (VRSN).
 5. SOUTHEAST PORTION OF WSDOT STORMWATER LINE HAS NOT BEEN SURVEYED.

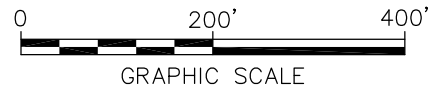

CHEVRON ENVIRONMENTAL MANAGEMENT COMPANY
 FORMER UNOCAL BULK FUEL TERMINAL
 EDMONDS, WASHINGTON
INTERIM ACTION WORK PLAN

**PRE-REMEDATION DISSOLVED TOTAL
 PETROLEUM HYDROCARBON
 CONCENTRATION AND LNAPL MAP (2006)**

FIGURE
3-1

CITY: EMV, CA DIV/GROUP: ENVCAD DB: ASR PM: TIME TR: LVR: ON=OFF=REF* (FRZ)
 G:\ENVCAD\Energy\file\ACT\B04536200500003\AMVP\DWG\B045362 B03-2.dwg LAYOUT: 3-2 SAVED: 10/28/2014 3:38 PM ACADVER: 18.1S (LMS TECH) PAGES: 18 PLOTTED: 10/30/2014 12:01 PM BY: REYES, ALEC
 XREFS: 45362X03 45362X02
 IMAGES: PROJECTNAME: I

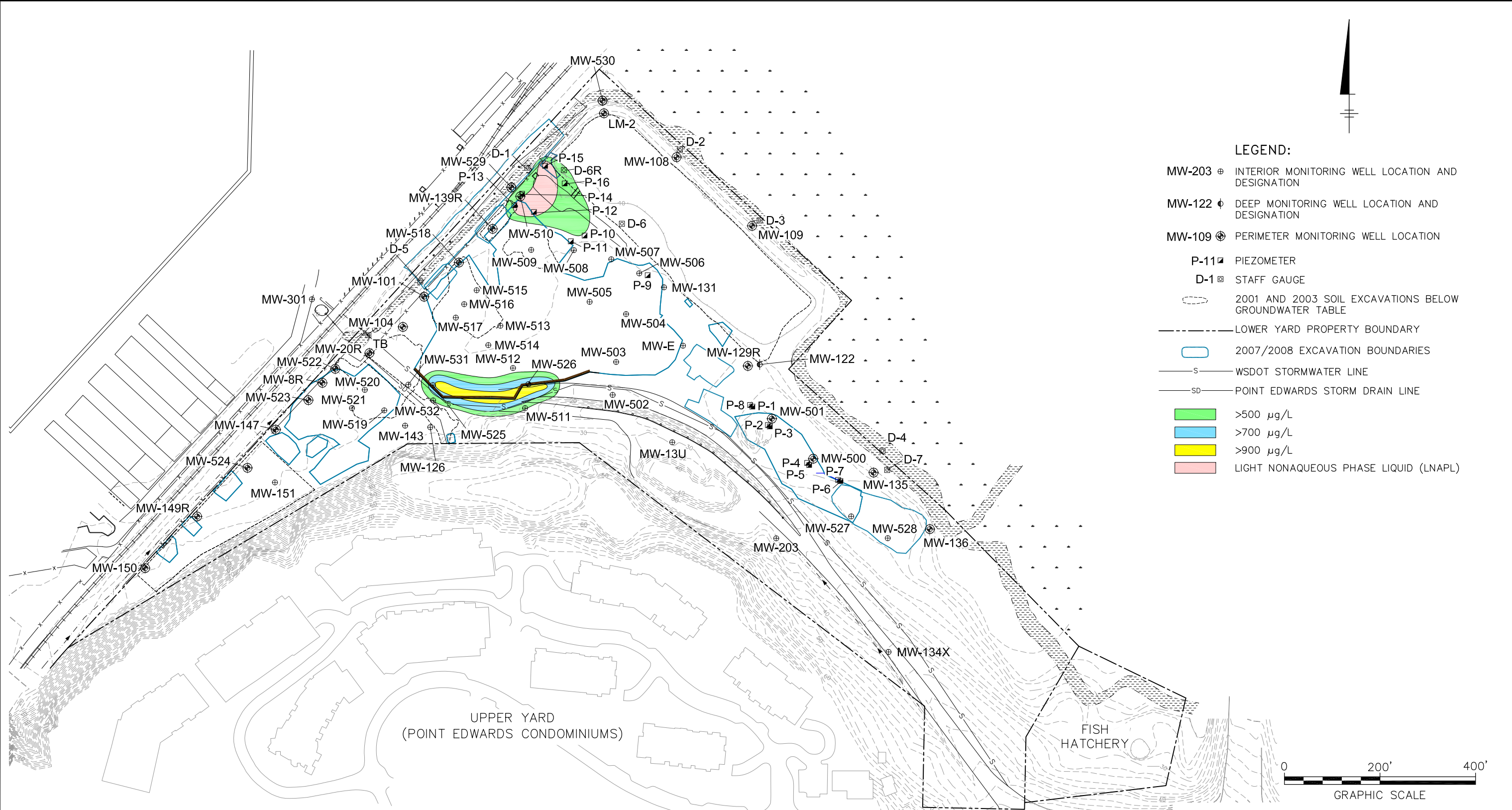

- LEGEND:**
- MW-203 ⊕ INTERIOR MONITORING WELL LOCATION AND DESIGNATION
 - MW-122 ⊕ DEEP MONITORING WELL LOCATION AND DESIGNATION
 - MW-109 ⊕ PERIMETER MONITORING WELL LOCATION
 - P-11 ▣ PIEZOMETER
 - D-1 ⊕ STAFF GAUGE
 - 2001 AND 2003 SOIL EXCAVATIONS BELOW GROUNDWATER TABLE
 - - - LOWER YARD PROPERTY BOUNDARY
 - 2007/2008 EXCAVATION BOUNDARIES
 - S - WSDOT STORMWATER LINE
 - SD - POINT EDWARDS STORM DRAIN LINE
 - >500 µg/L
 - >700 µg/L
 - >900 µg/L
 - LIGHT NONAQUEOUS PHASE LIQUID (LNAPL)

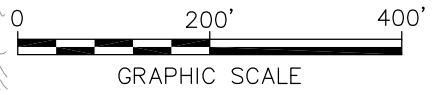
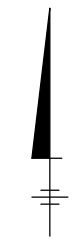

NOTES:

1. HORIZONTAL DATUM: WASHINGTON STATE COORDINATE SYSTEM NORTH ZONE (NAD 83/98). VERTICAL DATUM: N.A.V.D. 88. UNITS: U.S. SURVEY FEET. HORIZONTAL AND VERTICAL CONTROL ESTABLISHED BY GPS VIA VERTICAL REFERENCE STATION NETWORK (VRSN).
2. 20-MIL POLYETHYLENE SHEETING INSTALLED UPON COMPLETION OF PHASE I EXCAVATION. SHEETING REACHES TO APPROXIMATELY 7.5 FT ABOVE MEAN SEA LEVEL.
3. TOTAL TPH CALCULATED BY SUMMING THE CONCENTRATIONS OF GASOLINE, DIESEL, AND HEAVY OIL. FOR RESULTS WHICH DID NOT EXCEED METHOD REPORTING LIMITS, HALF OF THE REPORTING LIMIT WAS ADDED TO DETERMINE TOTAL TPH.
4. ALL CONCENTRATIONS IN MICROGRAMS PER LITER (µg/L).
5. UU = THE CONSTITUENTS MAKING UP THE TOTAL ARE ALL NON-DETECTS.
6. [] INDICATES DUPLICATE SAMPLE.
7. NS = NOT SAMPLED.
8. SOUTHEAST PORTION OF WSDOT STORMWATER LINE HAS NOT BEEN SURVEYED.

CHEVRON ENVIRONMENTAL MANAGEMENT COMPANY
 FORMER UNOCAL BULK FUEL TERMINAL
 EDMONDS, WASHINGTON
INTERIM ACTION WORK PLAN

**DISSOLVED TOTAL PETROLEUM
 HYDROCARBON CONCENTRATION AND
 LNAPL MAP (2014)**

FIGURE
3-2

CITY: EMV, CA DIV/GROUP: ENVCAD, DB: ASR, J. HARRIS, PM: TWE, TR: LVR, ONE="OFF=REF", (FRZ)
 C:\Users\hutchins\workspace\Deeptop\MAP\DWG\B01045362_B03-3.dwg, LAYOUT: 3-3, SAVER: 2/6/2015 1:32 PM, ACADVER: 18, IS (LMS TECH), PAGES: 18, PLOTTED: 2/6/2015 1:34 PM, BY: HUTCHINS-WASS, TAB: BATHA

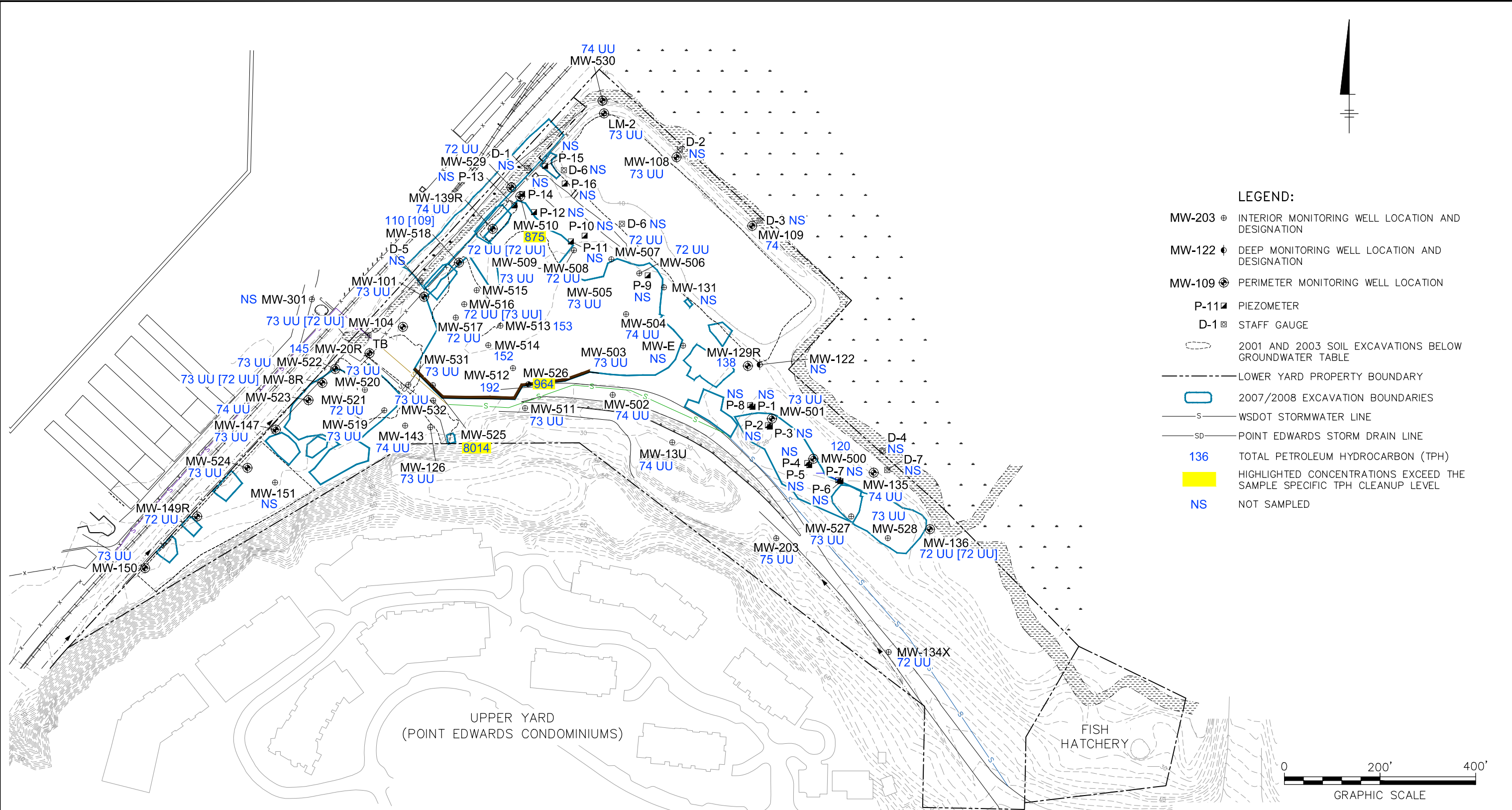

NOTES:

- HORIZONTAL DATUM: WASHINGTON STATE COORDINATE SYSTEM NORTH ZONE (NAD 83/98). VERTICAL DATUM: N.A.V.D. 88
 UNITS: U.S. SURVEY FEET
 HORIZONTAL AND VERTICAL CONTROL ESTABLISHED BY GPS VIA VERTICAL REFERENCE STATION NETWORK (VRSN).
- 20-MIL POLYETHYLENE SHEETING INSTALLED UPON COMPLETION OF PHASE I EXCAVATION. SHEETING REACHES TO APPROXIMATELY 7.5 FT ABOVE MEAN SEA LEVEL.
- TOTAL TPH CALCULATED BY SUMMING THE CONCENTRATIONS OF GASOLINE, DIESEL, AND HEAVY OIL. FOR RESULTS WHICH DID NOT EXCEED METHOD REPORTING LIMITS, HALF OF THE REPORTING LIMIT WAS ADDED TO DETERMINE TOTAL TPH.
- ALL CONCENTRATIONS IN MICROGRAMS PER LITER ($\mu\text{g/L}$).
- UU = THE CONSTITUENTS MAKING UP THE TOTAL ARE ALL NON-DETECTS.
- [] INDICATES DUPLICATE SAMPLE.
- NS = NOT SAMPLED.
- SOUTHEAST PORTION OF WSDOT STORMWATER LINE HAS NOT BEEN SURVEYED.

CHEVRON ENVIRONMENTAL MANAGEMENT COMPANY
 FORMER UNOCAL BULK FUEL TERMINAL
 EDMONDS, WASHINGTON
INTERIM ACTION WORK PLAN

**SECOND QUARTER 2014
 TOTAL TPH CONCENTRATIONS
 JUNE 16, 2014**

ARCADIS

FIGURE
3-3

CITY: EMV_CA DIV/GROUP: ENVCAD DB: ASR PM: TME TR: LVR: ON="OFF=REF" (FRZ)
 C:\Users\hutchinsw\OneDrive\Documents\45362X02\B044-1.dwg LAYOUT: 4-1 SAVER: 2/9/2015 2:51 PM
 ACADVER: 18.1S (LMS TECH) PAGES: 18 PLOTTED: 2/9/2015 2:51 PM BY: HUTCHINS-WASS, TABITHA
 XREFS: 45362X02 PROJECTNAME: 45362X03

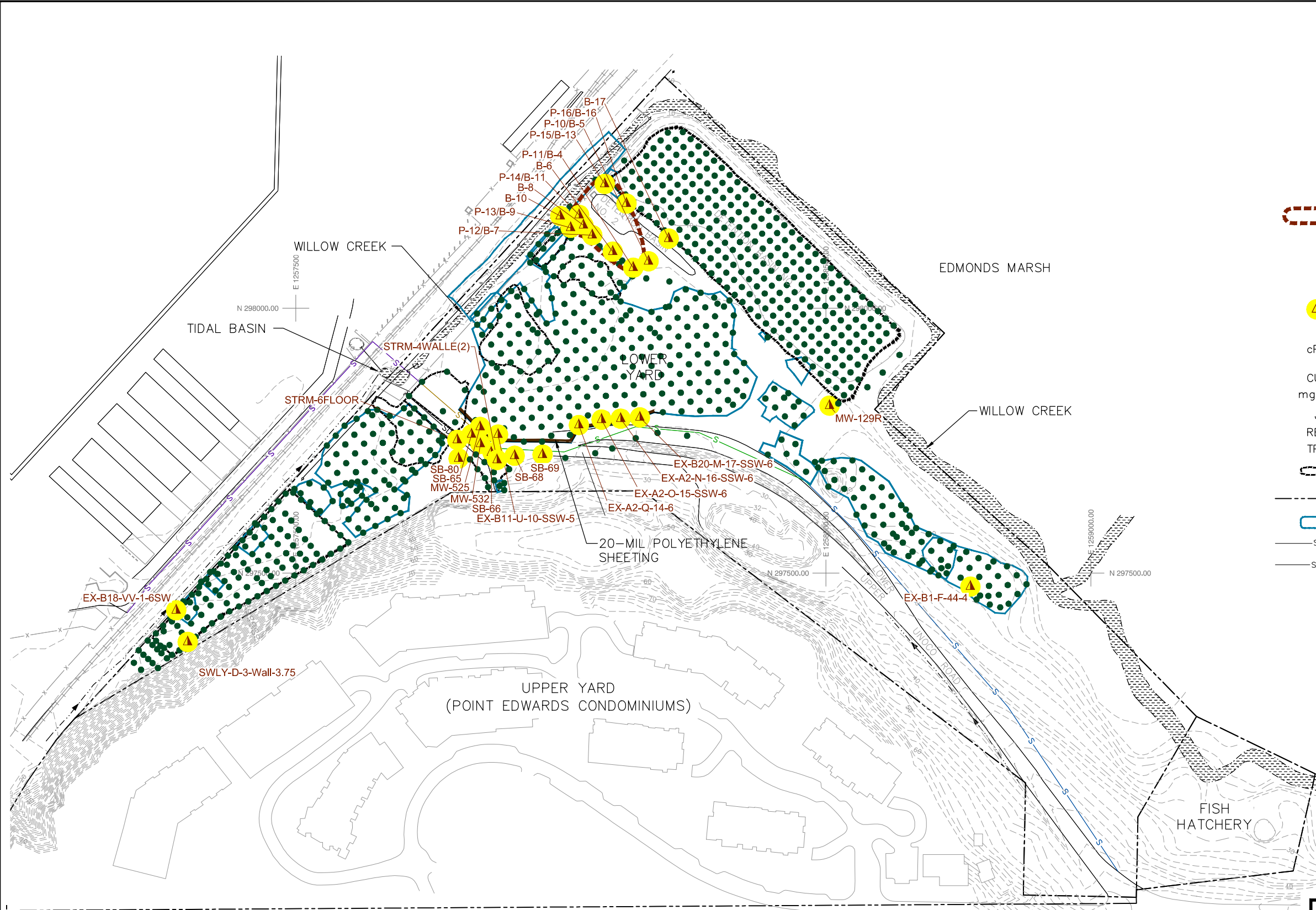

LEGEND:

- ESTIMATED RECOVERABLE LNAPL BOUNDARY
- SOIL SAMPLE COLLECTION LOCATION WITH CONCENTRATIONS OF TPH AND/OR cPAH AND/OR BENZENE NOT EXCEEDING APPLICABLE SITE CULs AND/OR RELs.
- SOIL SAMPLE COLLECTION LOCATION WITH CONCENTRATIONS OF TPH AND/OR cPAH, EXCEEDING APPLICABLE SITE CULs AND/OR RELs.
- cPAH CARCINOGENIC POLYNUCLEAR AROMATIC HYDROCARBONS, ADJUSTED FOR TOXICITY.
- CUL CLEANUP LEVEL
- mg/kg MILLIGRAMS PER KILOGRAM
- J INDICATES AN ESTIMATED VALUE
- REL REMEDIATION LEVEL
- TPH TOTAL PETROLEUM HYDROCARBONS
- 2001 AND 2003 SOIL EXCAVATIONS BELOW GROUNDWATER TABLE
- PROPERTY BOUNDARY
- 2007/2008 EXCAVATION BOUNDARIES
- WSDOT STORMWATER LINE
- POINT EDWARDS STORM DRAIN LINE

NOTES:

1. 20-MIL POLYETHYLENE SHEETING INSTALLED UPON COMPLETION OF PHASE I EXCAVATION. SHEETING REACHES TO APPROXIMATELY 7.5 FEET ABOVE MEAN SEA LEVEL.
2. HORIZONTAL DATUM: WASHINGTON STATE COORDINATE SYSTEM NORTH ZONE (NAD 83/98).
 VERTICAL DATUM: N.A.V.D. 88
 UNITS: U.S. SURVEY FEET
 HORIZONTAL AND VERTICAL CONTROL ESTABLISHED BY GPS VIA VERTICAL REFERENCE STATION NETWORK (VRSN).
3. SOUTHEAST PORTION OF WSDOT STORMWATER LINE HAS NOT BEEN SURVEYED.



CHEVRON ENVIRONMENTAL MANAGEMENT COMPANY
 FORMER UNOCO BULK FUEL TERMINAL
 EDMONDS, WASHINGTON
INTERIM ACTION WORK PLAN

**LOWER YARD REMAINING
 SOIL IMPACTS MAP**



FIGURE
4-1

CITY: EMV_CA DIV/GROUP: ENV/CAD DB: ASR PM: TME TR: LVR: ON=OFF=REF* (FRZ)
 G:\ENV\CAD\Energy\file\ACT\B04536200500003\MAP\DWG\B045362 B04-2.dwg LAYOUT: 4-2 SAVED: 10/20/2014 10:41 AM ACADVER: 18.1S (LMS TECH) PAGES: 18 PLOTTED: 10/29/2014 11:03 AM BY: REYES, ALEC
 XREFS: 45362X02 45362X03
 IMAGES: PROJECTNAME:

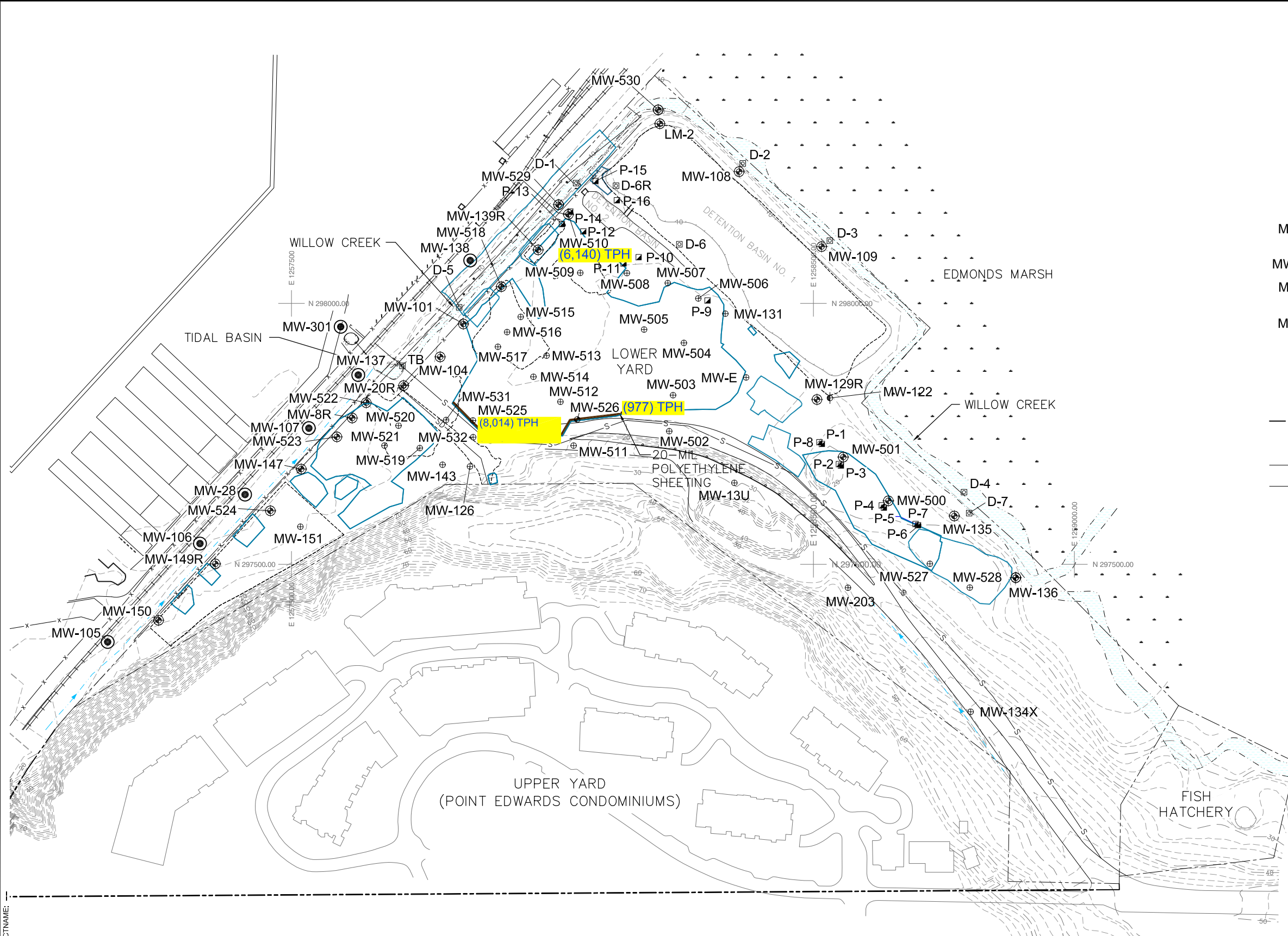

- LEGEND:**
- MW-203 ⊕ INTERIOR MONITORING WELL LOCATION AND DESIGNATION
 - MW-105 ⊙ BNSF MONITORING WELL LOCATION
 - MW-122 ⊕ DEEP MONITORING WELL LOCATION AND DESIGNATION
 - MW-109 ⊕ PERIMETER MONITORING WELL LOCATION
 - P-11 ▣ PIEZOMETER
 - D-1 ⊕ STAFF GAUGE
 - ⊖ 2001 AND 2003 SOIL EXCAVATIONS BELOW GROUNDWATER TABLE
 - PROPERTY BOUNDARY
 - ⬢ 2007/2008 EXCAVATION BOUNDARIES
 - S WSDOT STORMWATER LINE
 - SD POINT EDWARDS STORM DRAIN LINE
 - TPH TOTAL PETROLEUM HYDROCARBONS

- NOTES:**
1. 20-MIL POLYETHYLENE SHEETING INSTALLED UPON COMPLETION OF PHASE I EXCAVATION. SHEETING REACHES TO APPROXIMATELY 7.5 FEET ABOVE MEAN SEA LEVEL.
 2. HIGHLIGHTED NUMBERS ARE MAXIMUM CONCENTRATIONS OF TOTAL TPH IN MICROGRAMS PER LITER (ug/L) IN ALL WELLS THAT EXCEEDED GROUNDWATER CULs WITHIN THE PAST FOUR MONITORING EVENTS (SEPT. 2013 TO JUNE 2014).
 3. HORIZONTAL DATUM: WASHINGTON STATE COORDINATE SYSTEM NORTH ZONE (NAD 83/98). VERTICAL DATUM: N.A.V.D. 88
 UNITS: U.S. SURVEY FEET
 HORIZONTAL AND VERTICAL CONTROL ESTABLISHED BY GPS VIA VERTICAL REFERENCE STATION NETWORK (VRSN).
 4. SOUTHEAST PORTION OF WSDOT STORMWATER LINE HAS NOT BEEN SURVEYED.



CHEVRON ENVIRONMENTAL MANAGEMENT COMPANY
 FORMER UNOCAL BULK FUEL TERMINAL
 EDMONDS, WASHINGTON
INTERIM ACTION WORK PLAN

**LOWER YARD REMAINING
 GROUNDWATER IMPACTS MAP**

ARCADIS

FIGURE
4-2

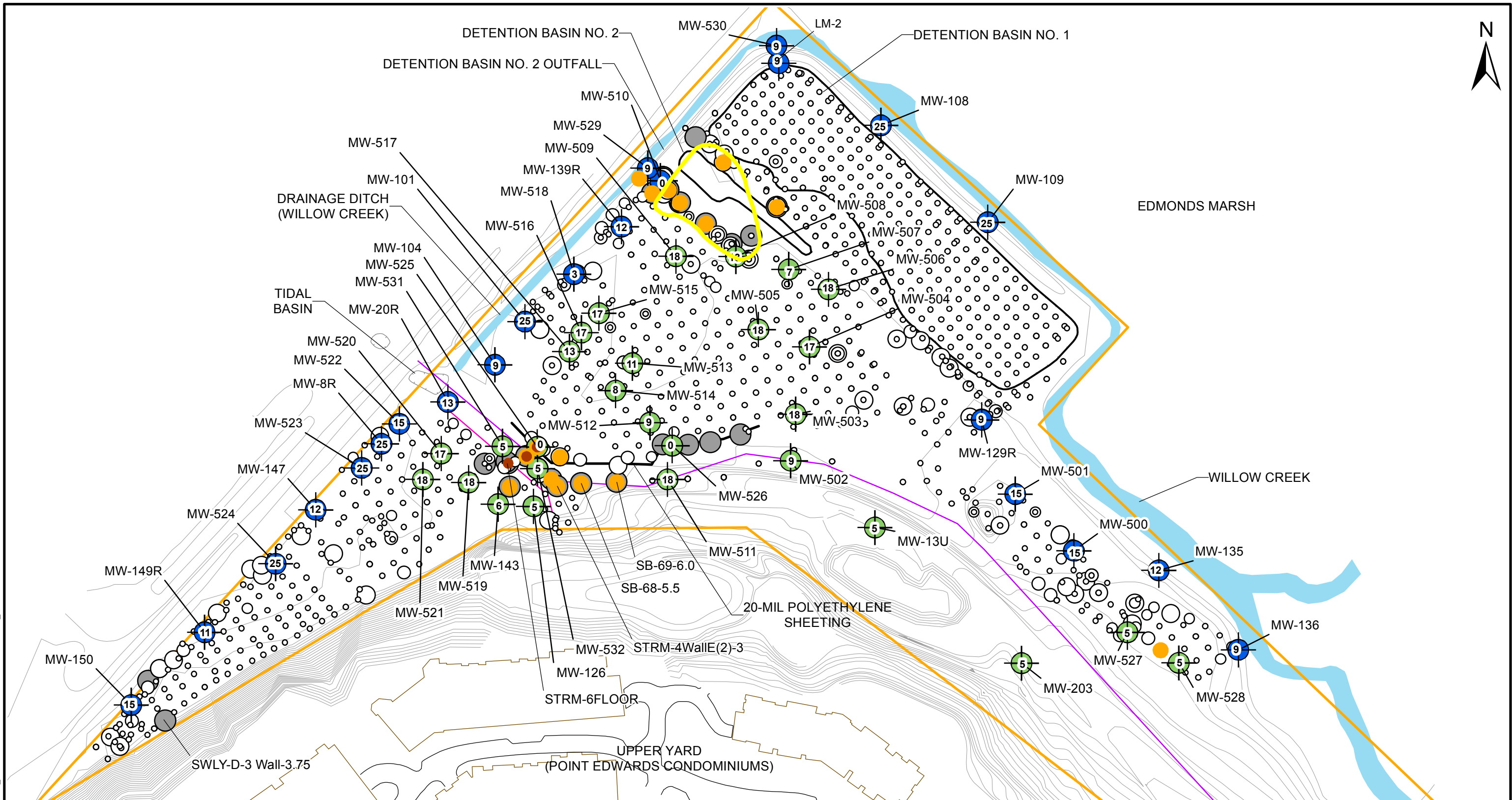

LEGEND

- | | | | |
|---|---|--|------------------------------|
| PERIMETER WELL AND NUMBER OF CONSECUTIVE SAMPLING ROUNDS SHOWING CONCENTRATIONS OF TPH LESS THAN PROPOSED GW CULS | SOIL TPH CONCENTRATION <250 mg/kg | SOIL BENZENE CONCENTRATION > CUL (18mg/kg) | ESTIMATED LNAPL BOUNDARY |
| INTERIOR WELL AND NUMBER OF CONSECUTIVE SAMPLING ROUNDS SHOWING CONCENTRATIONS OF TPH LESS THAN PROPOSED GW CULS | SOIL TPH CONCENTRATION OF 250 - 500 mg/kg | SOIL cPAH CONCENTRATION > CUL (0.14 mg/kg) | WSDOT STORMWATER LINE |
| | SOIL TPH CONCENTRATION OF 500 - 1,000 mg/kg | POINT EDWARDS STORM DRAIN LINE | LOWER YARD PROPERTY BOUNDARY |
| | SOIL TPH CONCENTRATION OF 1,000 - 2,775 mg/kg | | |
| | SOIL TPH CONCENTRATION > 2,775 mg/kg | | |

NOTES:
 1. 20-MIL POLYETHYLENE SHEETING INSTALLED UPON COMPLETION OF PHASE I EXCAVATION. SHEETING REACHES TO APPROXIMATELY 7.5 FEET ABOVE MEAN SEA LEVEL.
 2. SOUTHEAST PORTION OF WSDOT STORMWATER LINE HAS NOT BEEN SURVEYED.

TPH - TOTAL PETROLEUM HYDROCARBONS
 MG/KG - MILLIGRAMS PER KILOGRAM
 CPAH - CARCINOGENIC POLYNUCLEAR AROMATIC HYDROCARBONS, ADJUSTED FOR TOXICITY
 CUL - CLEANUP LEVEL

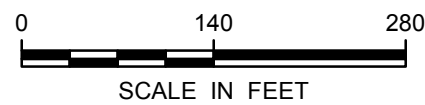

CHEVRON ENVIRONMENTAL MANAGEMENT COMPANY
 FORMER UNOCAL BULK FUEL TERMINAL
 EDMONDS, WASHINGTON
INTERIM ACTION WORK PLAN

SITE SOIL AND GROUNDWATER REMEDIATION STATUS - SECOND QUARTER 2014

ARCADIS

FIGURE 4-3

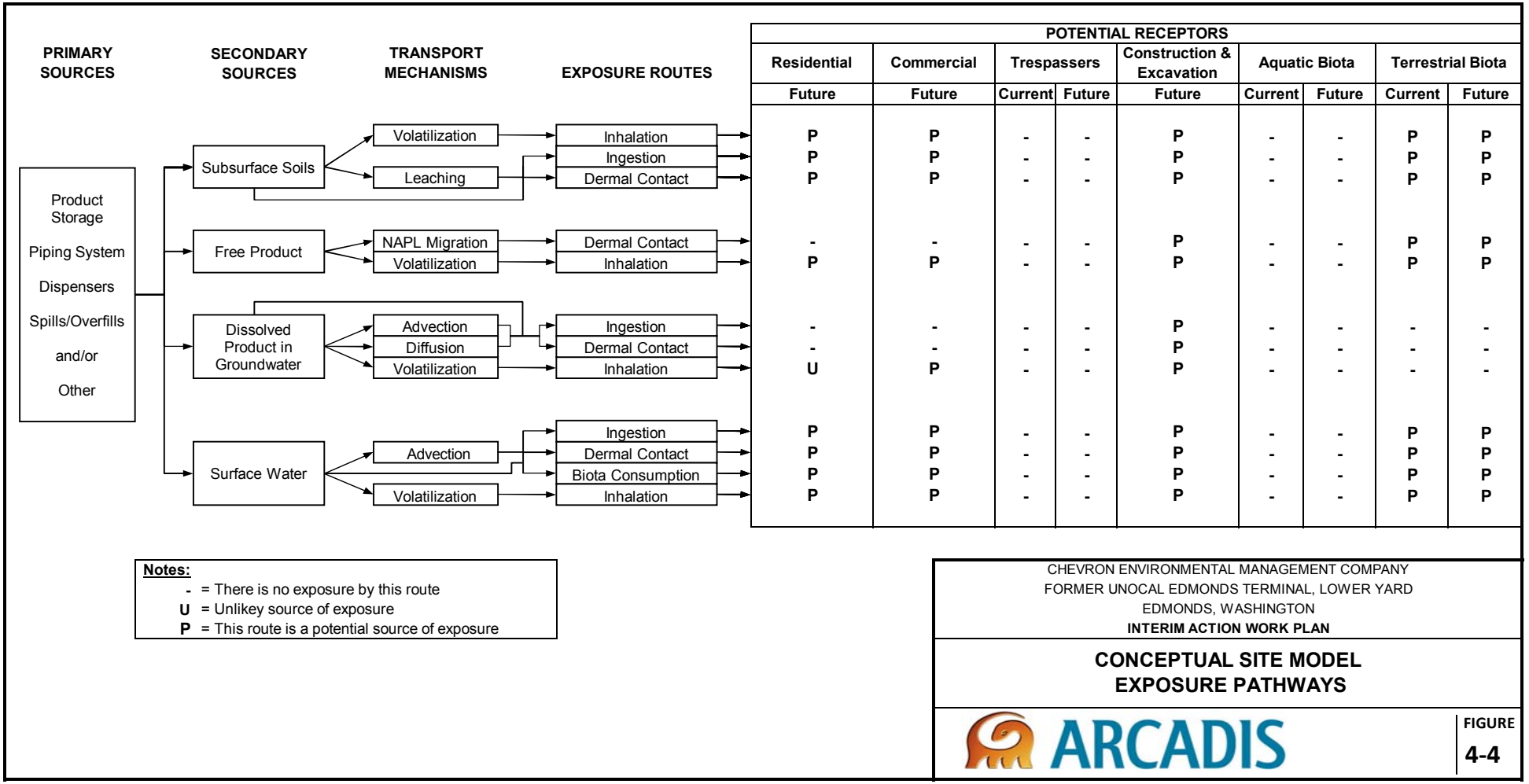

CITY: EMV, CA DIV/GROUP: ENVCAD DB: ASR PM: TME TR: LVR: ON="OFF" REF: (FR) I:\acad\proj\B004532\AWP\DWG\B004532_B07-1.dwg LAYOUT: 7-1 SAVED: 2/10/2015 4:32 PM ACADVER: 18.1S (LMS TECH) PAGES: 18 PLOTSTYLETABLE: PLTHALF.CTB PLOTTED: 5/8/2015 10:30 AM BY: HUTCHINS-WASS, TABITHA XREFS: IMAGES: PROJECTNAME: 48362X01 48362X02

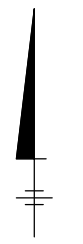
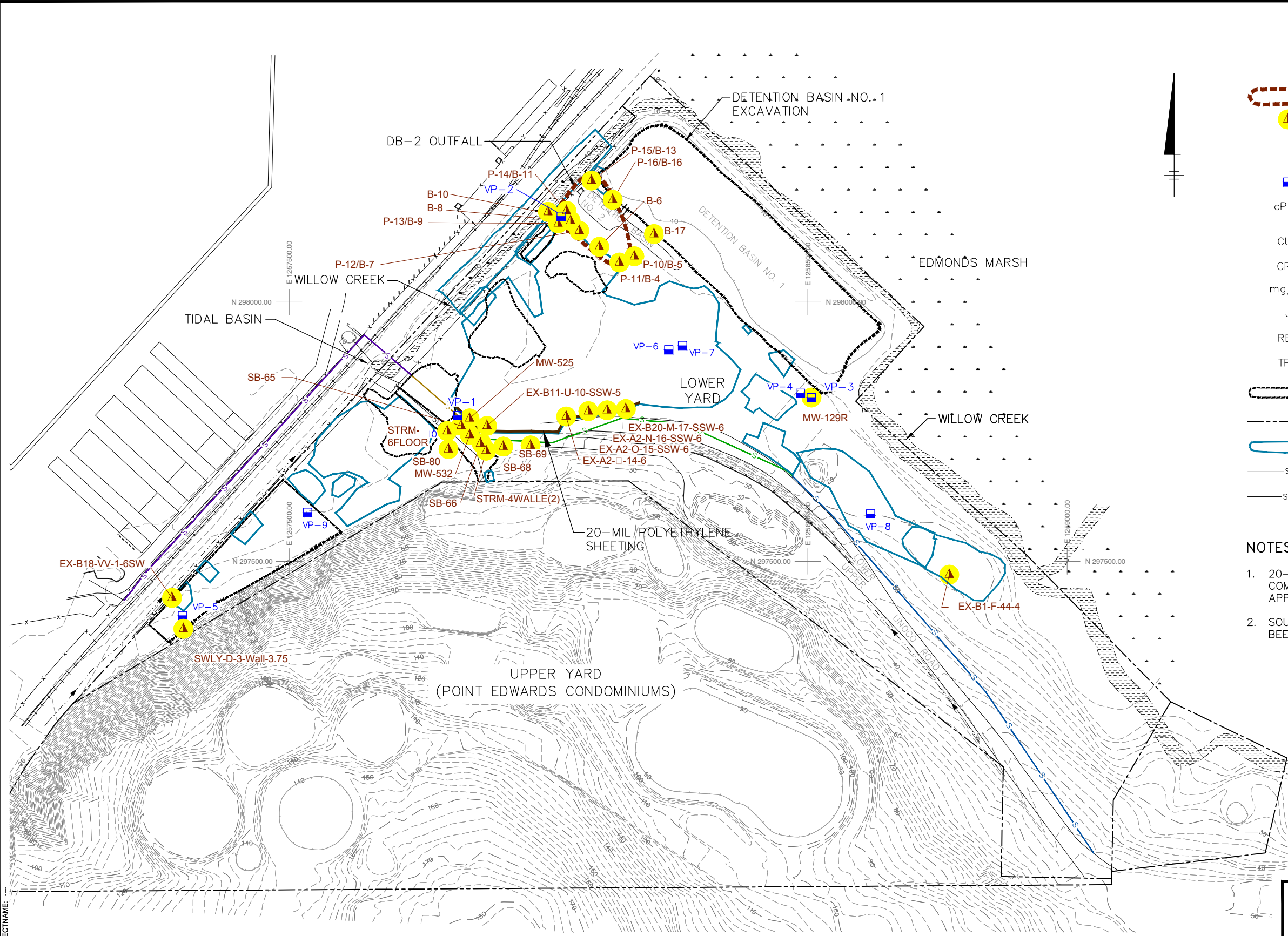

LEGEND:

	ESTIMATED RECOVERABLE LNAPL BOUNDARY
	SOIL SAMPLE COLLECTION LOCATION WITH CONCENTRATIONS OF TPH AND/OR cPAH, EXCEEDING APPLICABLE SITE CULs AND/OR RELs.
	SOIL VAPOR PROBE
cPAH	CARCINOGENIC POLYNUCLEAR AROMATIC HYDROCARBONS, ADJUSTED FOR TOXICITY
CUL	CLEANUP LEVEL
GRO	GASOLINE RANGE HYDROCARBONS
mg/kg	MILLIGRAMS PER KILOGRAM
J	INDICATES AN ESTIMATED VALUE
REL	REMEDIATION LEVEL
TPH	TOTAL PETROLEUM HYDROCARBONS
	2001 AND 2003 SOIL EXCAVATIONS BELOW GROUNDWATER TABLE
	LOWER YARD PROPERTY BOUNDARY
	2007/2008 EXCAVATION BOUNDARIES
	WSDOT STORMWATER LINE
	POINT EDWARDS STORM DRAIN LINE

- NOTES:**
- 20-MIL POLYETHYLENE SHEETING INSTALLED UPON COMPLETION OF PHASE I EXCAVATION. SHEETING REACHES TO APPROXIMATELY 7.5 FEET ABOVE MEAN SEA LEVEL.
 - SOUTHEAST PORTION OF WSDOT STORMWATER LINE HAS NOT BEEN SURVEYED.

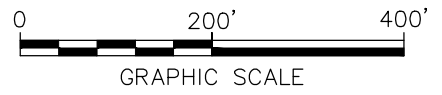

CHEVRON ENVIRONMENTAL MANAGEMENT COMPANY
FORMER UNOCAL BULK FUEL TERMINAL
EDMONDS, WASHINGTON
INTERIM ACTION WORK PLAN

ADDITIONAL SOIL VAPOR ASSESSMENT LOCATIONS

FIGURE
7-1

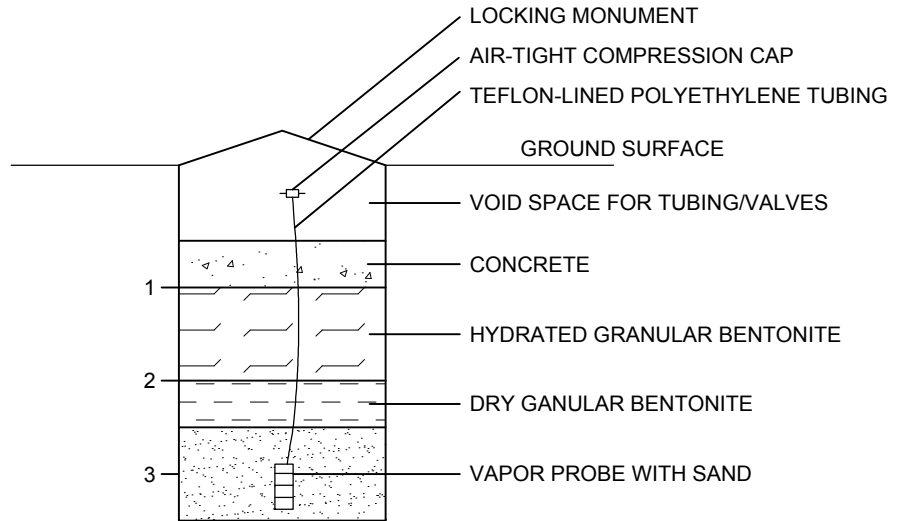

NOT TO SCALE

NOTE:

VAPOR PROBE IS CONSTRUCTED WITH A 6-INCH, 0.375-INCH OUTER DIAMETER STAINLESS STEEL SOIL VAPOR SCREEN.

CHEVRON ENVIRONMENTAL MANAGEMENT COMPANY
 FORMER UNOCAL BULK FUEL TERMINAL
 EDMONDS, WASHINGTON
INTERIM ACTION WORK PLAN

**SHALLOW SOIL VAPOR PROBE
 SCHEMATIC DIAGRAM**



FIGURE
7-2

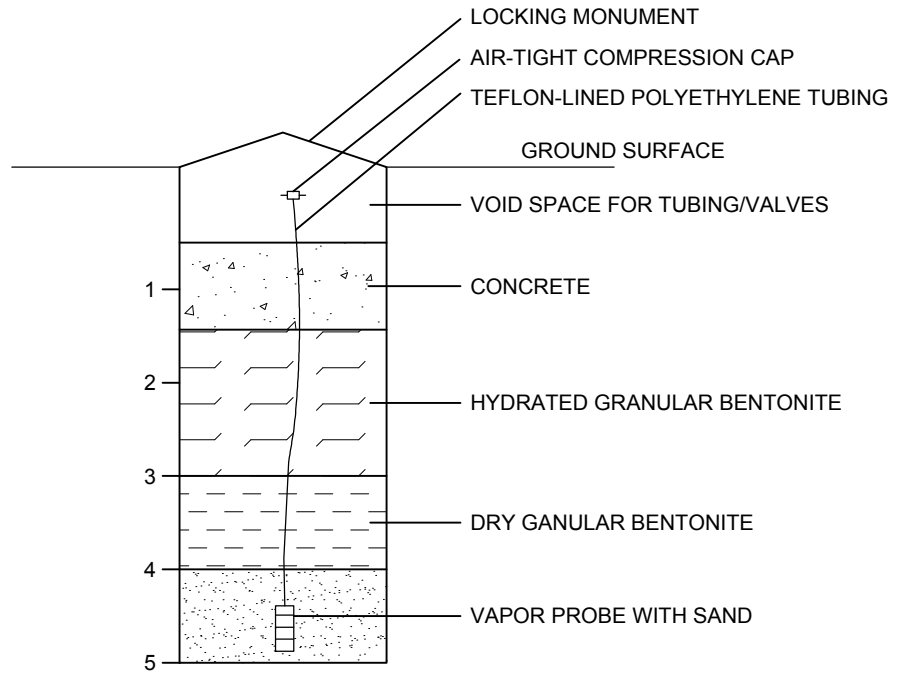

NOT TO SCALE

NOTE:

VAPOR PROBE IS CONSTRUCTED WITH A 6-INCH, 0.375-INCH OUTER DIAMETER STAINLESS STEEL SOIL VAPOR SCREEN.

CHEVRON ENVIRONMENTAL MANAGEMENT COMPANY
 FORMER UNOCAL BULK FUEL TERMINAL
 EDMONDS, WASHINGTON
INTERIM ACTION WORK PLAN

**DEEP SOIL VAPOR PROBE SCHEMATIC
 DIAGRAM**



FIGURE
7-3

CITY:\Reed\DIV\GROUP\Reed\DB\Reed\LD\Opt\PM\Reed\TM\Opt\LYR\Opt\ON*OFF=REF*
 C:\Users\hutchins\w\w\Desktop\AWP\DWG\G18044532\B08-L.dwg LAYOUT: 8-1 SAVED: 2/9/2015 3:06 PM ACADVER: 18.1S (LMS TECH) PAGES: 18 PLOTTED: 2/10/2015 3:19 PM BY: HUTCHINS-WASS, TABITHA
 XREFS: 45362X02
 PROJECTNAME:

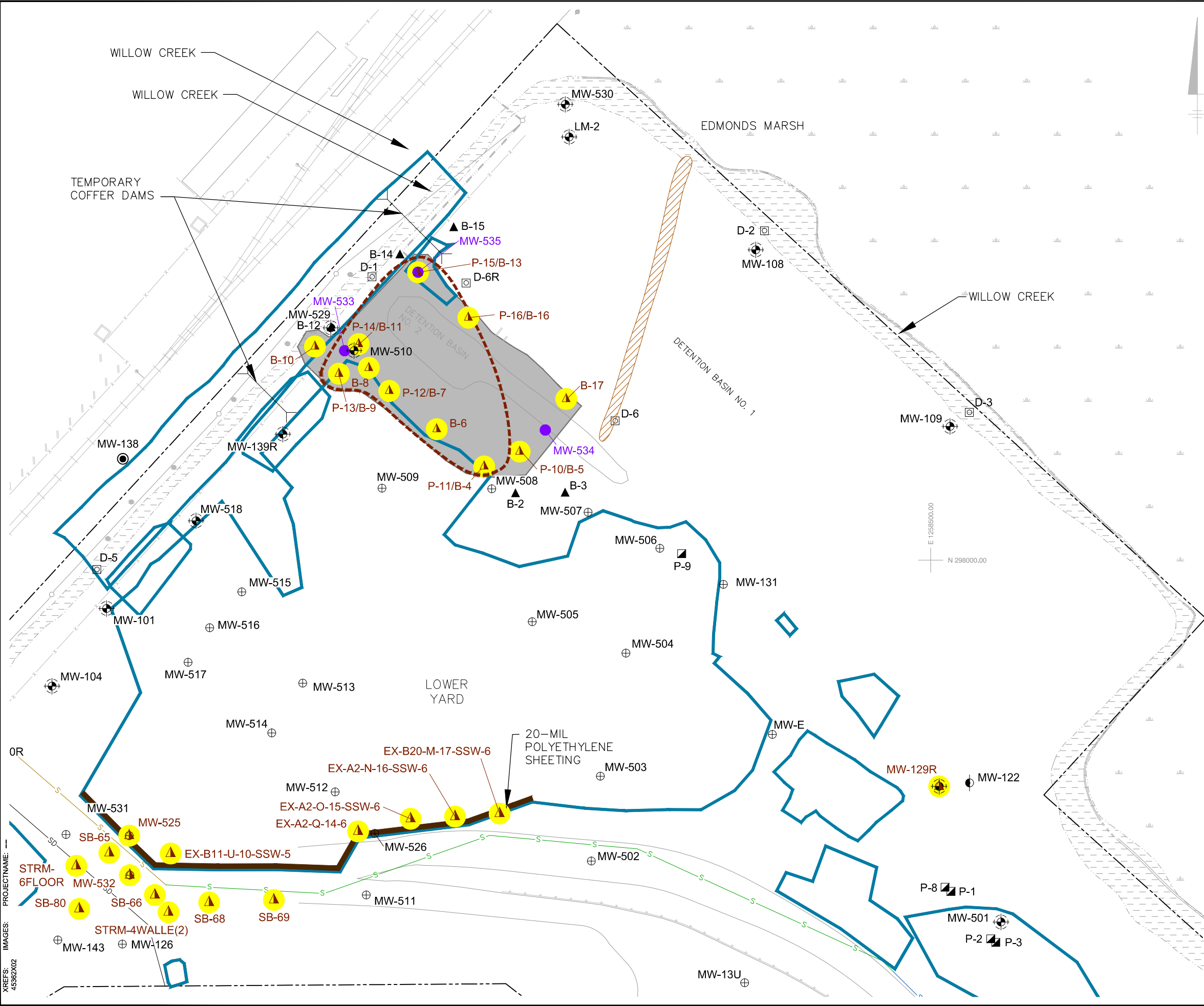

LEGEND:

- ESTIMATED RECOVERABLE LNAPL BOUNDARY
- SOIL SAMPLE COLLECTION LOCATION WITH CONCENTRATIONS OF TPH AND/OR cPAH, EXCEEDING APPLICABLE SITE CULs AND/OR RELs.
- cPAH CARCINOGENIC POLYNUCLEAR AROMATIC HYDROCARBONS, ADJUSTED FOR TOXICITY.
- CUL CLEANUP LEVEL
- REL REMEDIATION LEVEL
- TPH TOTAL PETROLEUM HYDROCARBONS
- MW-203 INTERIOR MONITORING WELL LOCATION AND DESIGNATION
- MW-122 DEEP MONITORING WELL LOCATION AND DESIGNATION
- MW-109 PERIMETER MONITORING WELL LOCATION
- MW-301 BNSF WELLS
- MW-533 PROPOSED MONITORING WELL LOCATION
- P-11 PIEZOMETER
- D-1 STAFF GAUGE
- DPE-12 PROPOSED DUAL PHASE EXTRACTION WELL (DPE)
- 2007/2008 EXCAVATION BOUNDARIES
- PROPERTY BOUNDARY
- WSDOT STORMWATER LINE
- POINT EDWARDS STORM DRAIN LINE
- SOIL BORING
- EXCAVATION BOUNDARY
- TEMPORARY EARTHEN BERM

- NOTES:**
1. 20-MIL POLYETHYLENE SHEETING INSTALLED UPON COMPLETION OF PHASE I EXCAVATION. SHEETING REACHES TO APPROXIMATELY 7.5 FEET ABOVE MEAN SEA LEVEL.
 2. HORIZONTAL DATUM: WASHINGTON STATE COORDINATE SYSTEM NORTH ZONE (NAD 83/98). VERTICAL DATUM: N.A.V.D. 88. UNITS: U.S. SURVEY FEET. HORIZONTAL AND VERTICAL CONTROL ESTABLISHED BY GPS VIA VERTICAL REFERENCE STATION NETWORK (VRSN).
 3. SOUTHEAST PORTION OF WSDOT STORMWATER LINE HAS NOT BEEN SURVEYED.

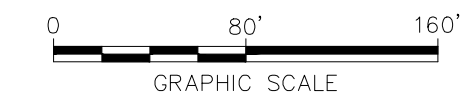

CHEVRON ENVIRONMENTAL MANAGEMENT COMPANY
 FORMER UNOCAL BULK FUEL TERMINAL
 EDMONDS, WASHINGTON
INTERIM ACTION WORK PLAN

**EXCAVATION OF THE DETENTION
 BASIN 2 (DB-2) VICINITY PLAN**

FIGURE
8-1

XREFS: IMAGES: PROJECTNAME: ---

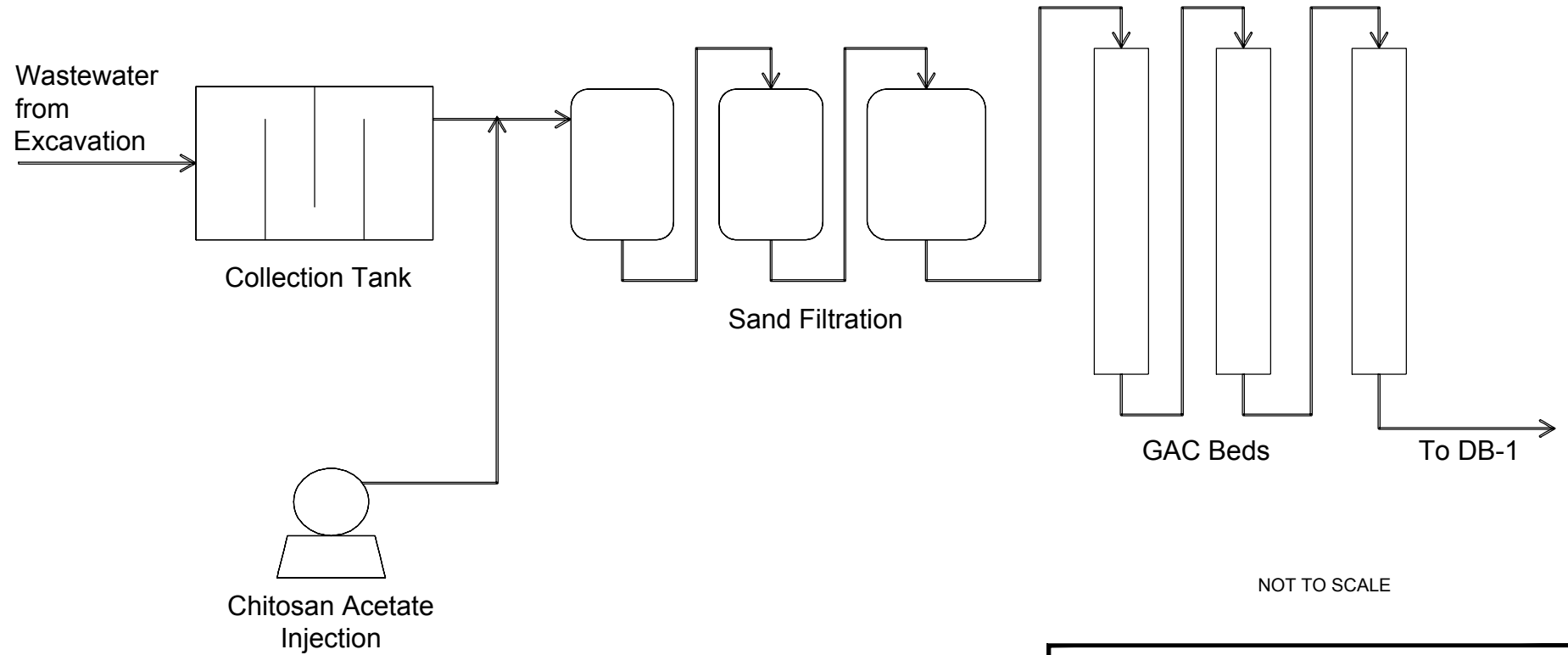

GAC = Granular Activated Carbon

CHEVRON ENVIRONMENTAL MANAGEMENT COMPANY
FORMER UNOCAL BULK FUEL TERMINAL
EDMONDS, WASHINGTON
INTERIM ACTION WORK PLAN

**TEMPORARY WATER TREATMENT
SYSTEM FLOW DIAGRAM**



FIGURE
8-2

CITY: EMV, CA DIV/GROUP: ENVCAD, DB: ASR, PM: TME, TR: LYR, ON: OFF=REF, (FRZ)
 C:\Users\hutchinsw\OneDrive\Documents\45362X02.dwg LAYOUT: 8-3, SAVED: 2/10/2015 3:16 PM, ACADVER: 18.1, S (LMS TECH), PAGES: 18, PLOTSTYLETABLE: PLTHALF.CTB, PLOTTED: 2/10/2015 3:17 PM, BY: HUTCHINS-WASS, TAB: THA
 XREFS: 45362X02, 45362X03
 IMAGES: PROJECTNAME: --

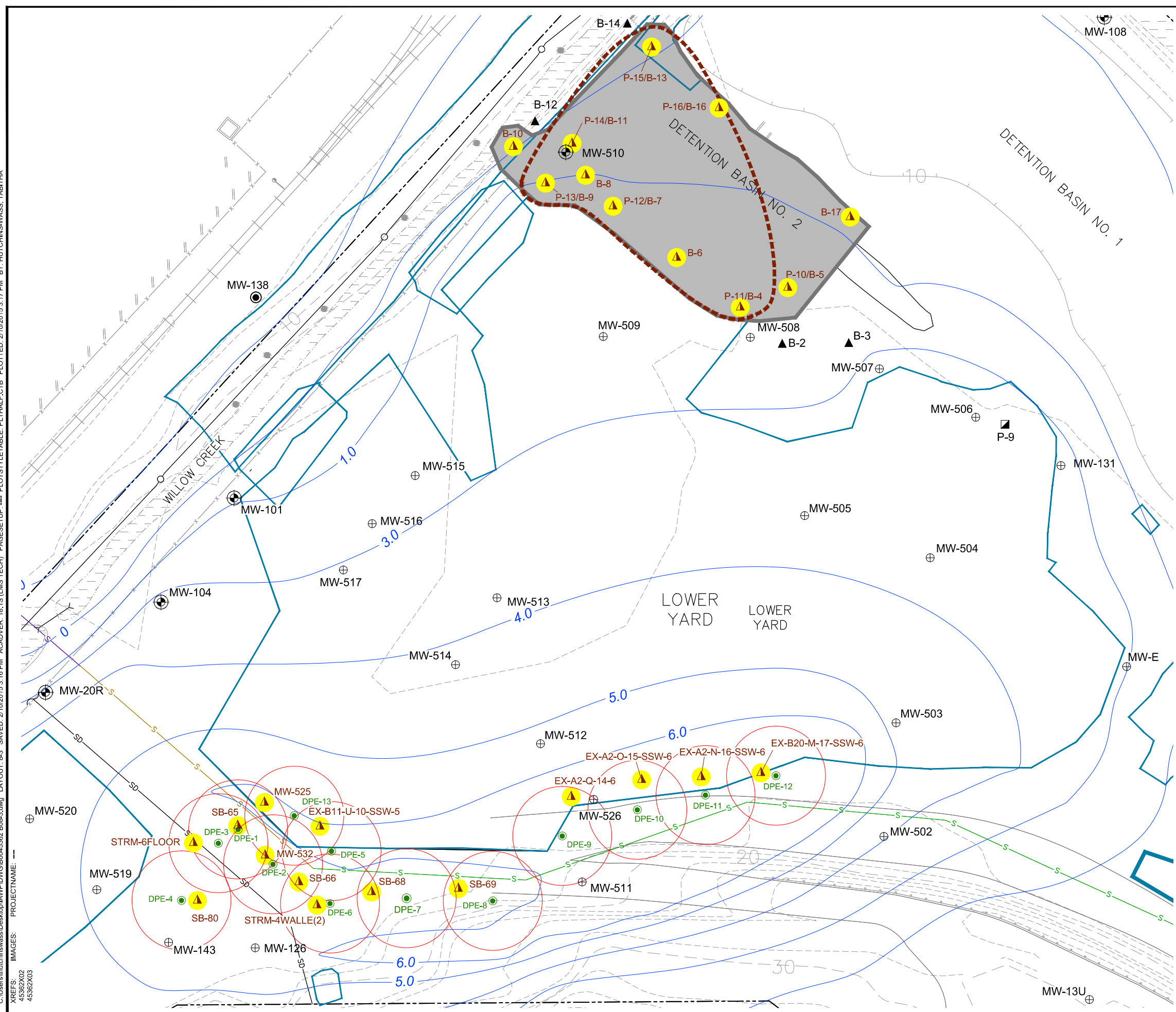

LEGEND:

- ESTIMATED RECOVERABLE LNAPL BOUNDARY
- MW-203 ⊕ INTERIOR MONITORING WELL LOCATION AND DESIGNATION
- MW-122 ⊕ DEEP MONITORING WELL LOCATION AND DESIGNATION
- MW-108 ⊕ PERIMETER MONITORING WELL LOCATION
- MW-301 ⊕ BNSF WELL LOCATION
- P-9 ▴ PIEZOMETER
- SOIL SAMPLE COLLECTION LOCATION WITH CONCENTRATIONS OF TPH AND/OR cPAH, EXCEEDING APPLICABLE SITE CULs AND/OR RELs.
- cPAH CARCINOGENIC POLYNUCLEAR AROMATIC HYDROCARBONS, ADJUSTED FOR TOXICITY.
- CUL CLEANUP LEVEL
- REL REMEDIATION LEVEL
- TPH TOTAL PETROLEUM HYDROCARBONS
- EXCAVATION BOUNDARY
- PROPERTY BOUNDARY
- 2007/2008 EXCAVATION BOUNDARIES
- WSDOT STORMWATER LINE
- POINT EDWARDS STORM DRAIN LINE
- 1.0 GROUNDWATER CONTOURS – PRESENTED AS STEADY STATE POTENTIOMETRIC DRAWDOWN @ 21 GPM TOTAL
- DPE-12 ● PROPOSED DUAL PHASE EXTRACTION WELL (DPE)
- ESTIMATED DPE ROI – 30 FOOT RADIUS OF INFLUENCE

- NOTES:**
1. HORIZONTAL DATUM: WASHINGTON STATE COORDINATE SYSTEM NORTH ZONE (NAD 83/98).
 VERTICAL DATUM: N.A.V.D. 88
 UNITS: U.S. SURVEY FEET
 HORIZONTAL AND VERTICAL CONTROL ESTABLISHED BY GPS VIA VERTICAL REFERENCE STATION NETWORK (VRSN).
 2. SOUTHEAST PORTION OF WSDOT STORMWATER LINE HAS NOT BEEN SURVEYED.

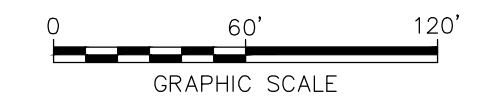

CHEVRON ENVIRONMENTAL MANAGEMENT COMPANY
 FORMER UNOCAL BULK FUEL TERMINAL
 EDMONDS, WASHINGTON
INTERIM ACTION WORK PLAN

MODFLOW GROUNDWATER EXTRACTION MODEL

ARCADIS

FIGURE **8-3**

CITY: EMV, CA DIV/GROUP: ENV/CAD DB: ASR PM: TME TR: LYR: ON=OFF=REF* (FRZ) G:\ENV\CAD\Energy\file\ACT\B045362\005\0003\AVP\DWG\B045362 D05-5.dwg LAYOUT: 8-5 SAVED: 10/30/2014 11:28 AM ACADVER: 18.1S (LMS TECH) PAGES: 11/17/2014 10:36 AM BY: REYES, ALEC XREFS: IMAGES: PROJECTNAME: --

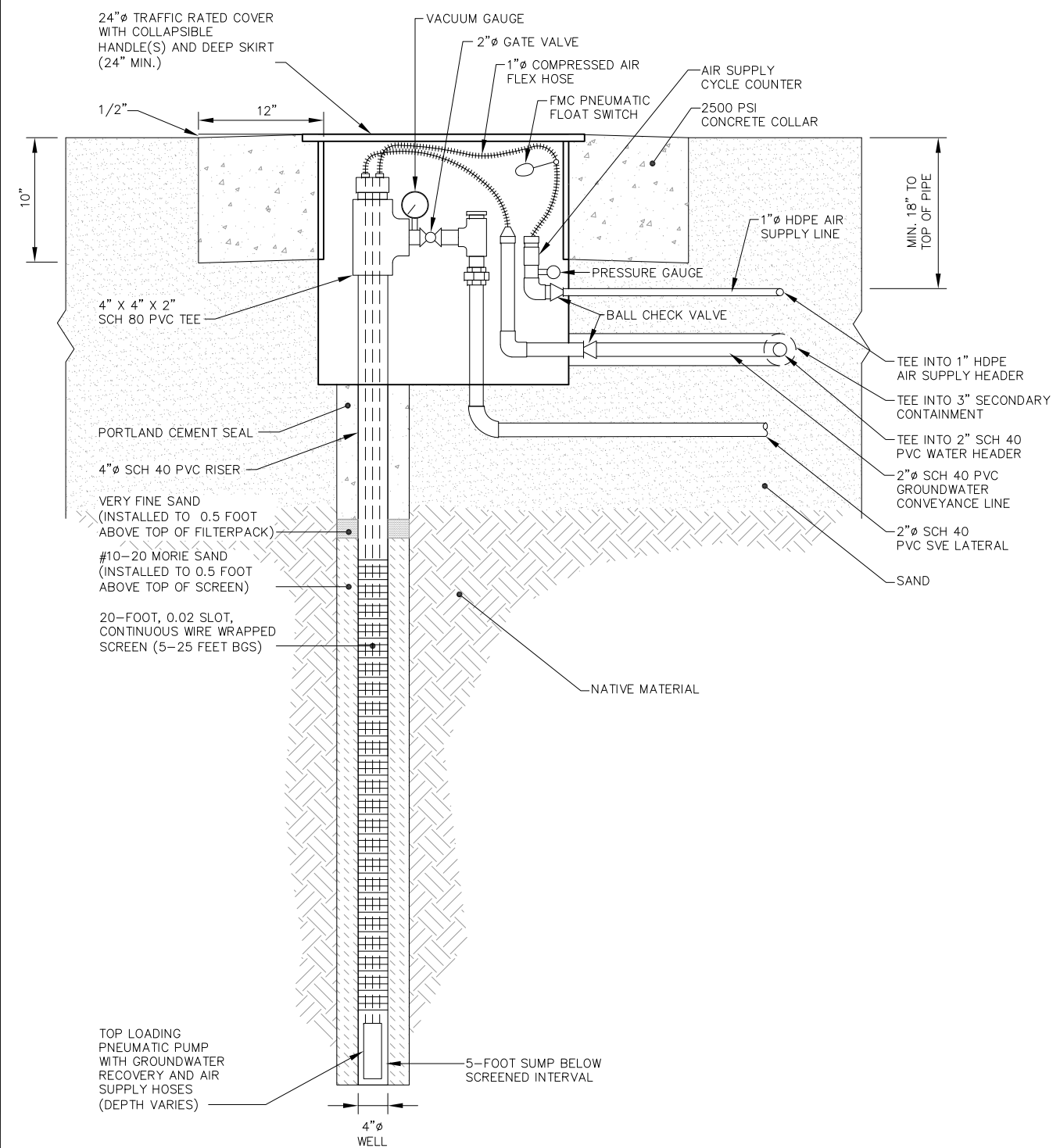

DUAL-PHASE EXTRACTION WELL CONNECTION DETAIL
 NOT TO SCALE

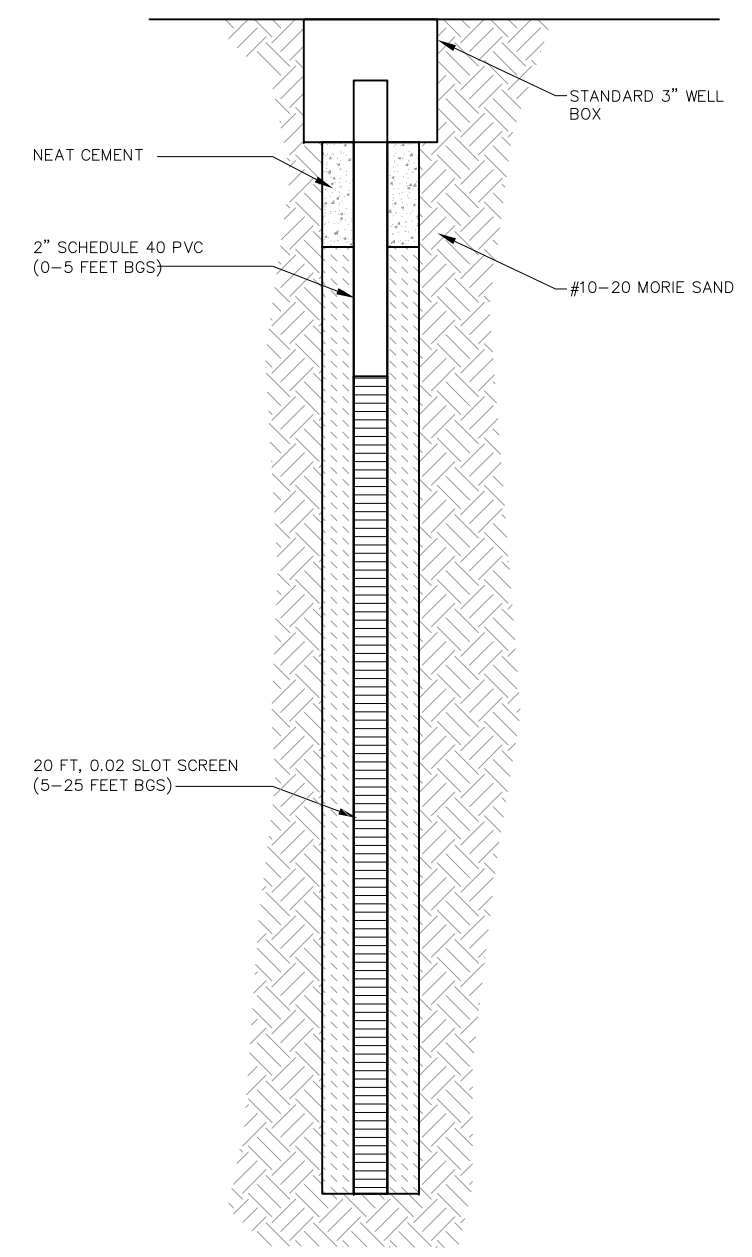

PIEZOMETER WELL DETAIL
 NOT TO SCALE

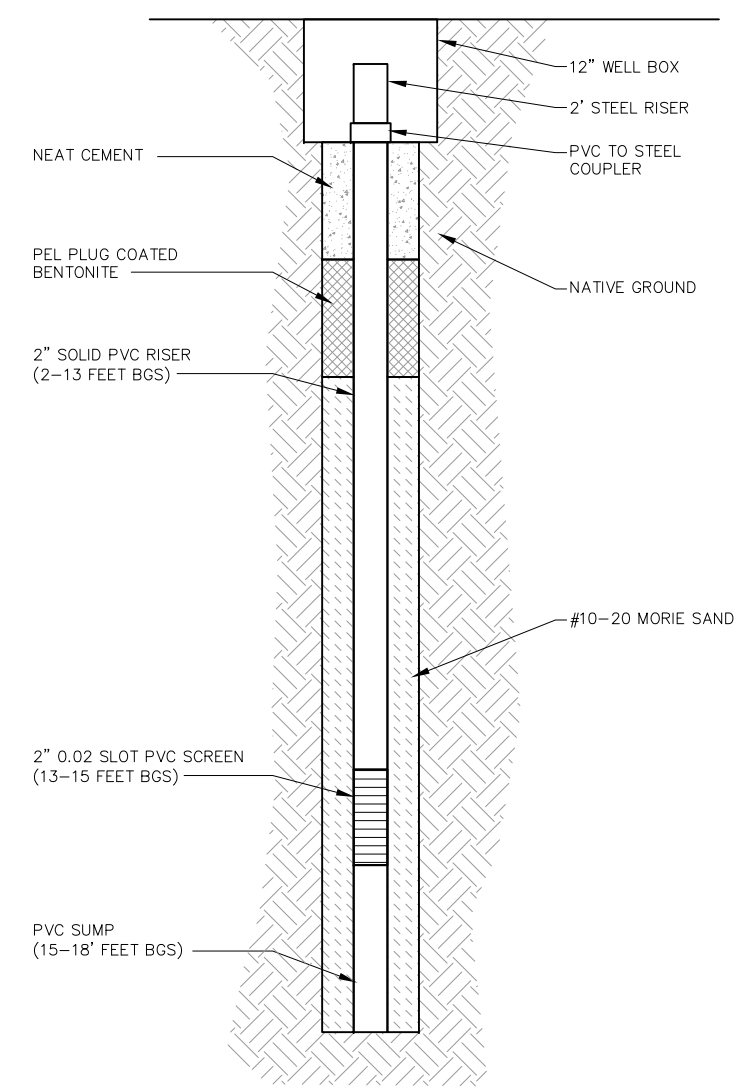

AS WELL DETAIL
 NOT TO SCALE

CHEVRON ENVIRONMENTAL MANAGEMENT COMPANY FORMER UNOCAL BULK FUEL TERMINAL EDMONDS, WASHINGTON INTERIM ACTION WORK PLAN	
AS, DPE, AND PIEZOMETER WELL DETAILS	
	FIGURE 8-5

CITY: PHOENIX, AZ DIV/GROUP: EN/CAD DE: A. REYES, T. HUTCHINS/WASS, J. HARRIS
 \arcadis-us.com\office\data\San Rafael-CANV/CAD/San Rafael/RETURN-TOP/Phoenix-AZ/B0045362/B09-2.dwg LAYOUT: 9-2 SAVED: 2/10/2015 10:12 PM ACADVER: 18.15 (LMS TECH) PAGES: 1 PLOTSTYLETABLE: PLTHALF.CTB PLOTTED: 7/10/2015 4:40
 PW: B.Y. HARRIS, JESSICA
 XREFS: IMAGES: PROJECTNAME: 45362X02 45362X03

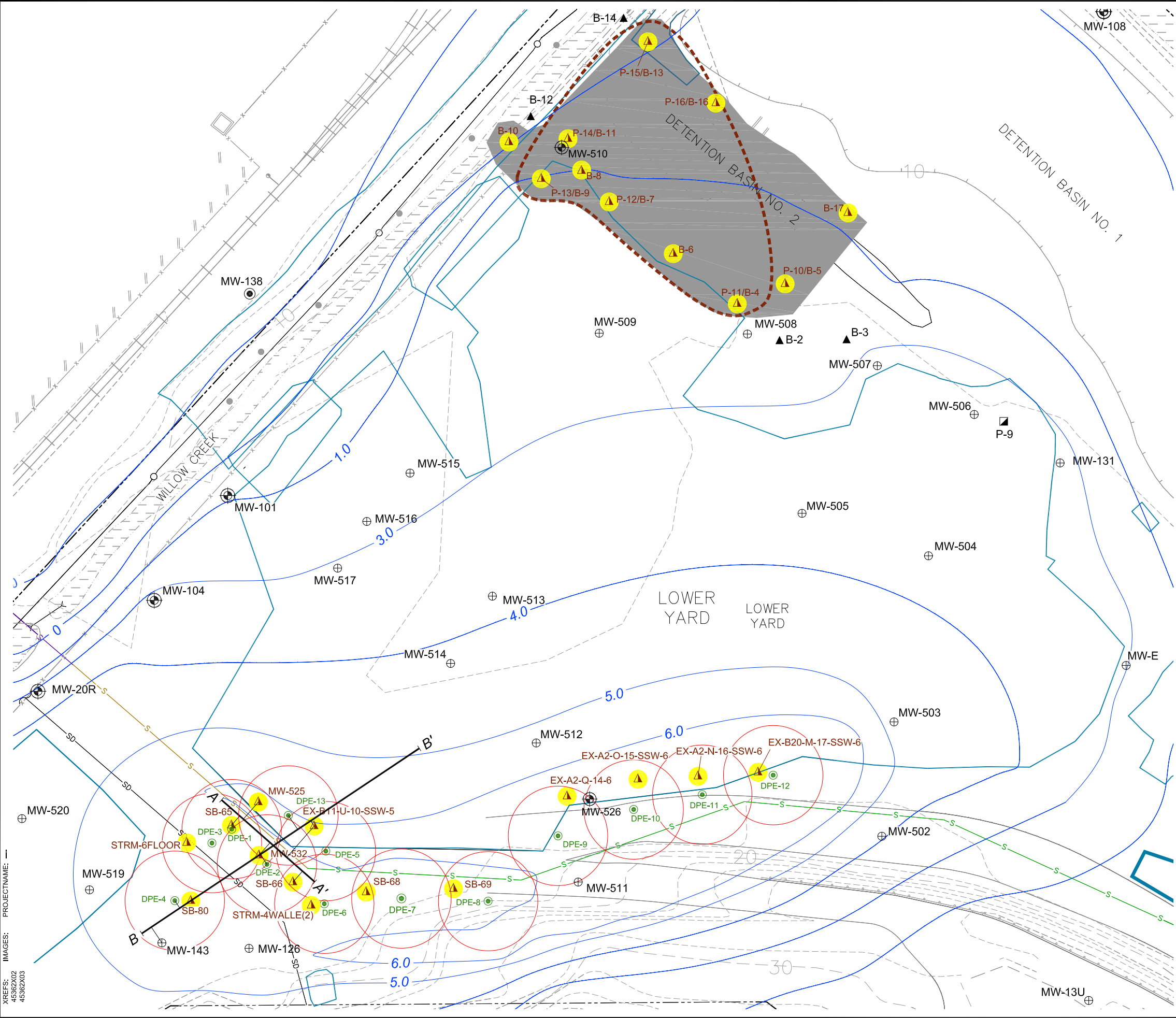

- LEGEND:**
- ESTIMATED RECOVERABLE LNAPL BOUNDARY
 - MW-203 ⊕ INTERIOR MONITORING WELL LOCATION AND DESIGNATION
 - MW-122 ⊕ DEEP MONITORING WELL LOCATION AND DESIGNATION
 - MW-108 ⊕ PERIMETER MONITORING WELL LOCATION
 - MW-301 ⊕ BNSF WELL LOCATION
 - P-9 ▴ PIEZOMETER
 - SB-80 ▲ SOIL SAMPLE COLLECTION LOCATION WITH CONCENTRATIONS OF TPH AND/OR cPAH EXCEEDING APPLICABLE SITE CULS AND/OR RELs
 - DPE-12 ⊕ PROPOSED DUAL PHASE EXTRACTION WELL (DPE)
 - AREA OF EXCAVATION
 - PROPERTY BOUNDARY
 - 2007/2008 EXCAVATION BOUNDARIES
 - S WSDOT STORMWATER LINE
 - SD POINT EDWARDS STORM DRAIN LINE
 - 1.0 GROUNDWATER CONTOURS – PRESENTED AS STEADY STATE POTENTIOMETRIC DRAWDOWN @ 21 GPM TOTAL
 - ESTIMATED DPE ROI-30 FOOT RADIUS OF INFLUENCE
 - A—A' CROSS SECTION PROFILE LOCATION
 - cPAH CARCINOGENIC POLYNUCLEAR AROMATIC HYDROCARBONS, ADJUSTED FOR TOXICITY
 - TPH TOTAL PETROLEUM HYDROCARBONS
 - CUL CLEANUP LEVEL
 - REL REMEDIATION LEVEL

- NOTES:**
1. HORIZONTAL DATUM: WASHINGTON STATE COORDINATE SYSTEM NORTH ZONE (NAD 83/98).
 VERTICAL DATUM: N.A.V.D. 88
 UNITS: U.S. SURVEY FEET
 HORIZONTAL AND VERTICAL CONTROL ESTABLISHED BY GPS VIA VERTICAL REFERENCE STATION NETWORK (VRSN).
 2. SOUTHEAST PORTION OF WSDOT STORMWATER LINE HAS NOT BEEN SURVEYED.

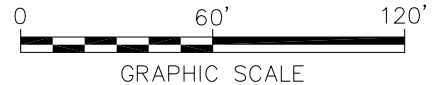

CHEVRON ENVIRONMENTAL MANAGEMENT COMPANY
 FORMER UNOCAL BULK FUEL TERMINAL
 EDMONDS, WASHINGTON
INTERIM ACTION WORK PLAN

**DPE SYSTEM CROSS SECTION
 LOCATION MAP**

FIGURE
9-2

CITY: PHOENIX, AZ DIV/GROUP: ENVCAD DR: A, REYES, T. HUTCHINS-WASS, J. HARRIS
 I:\arcad\proj\B0045362\IAWP\DWG\B0045362_V08-XSect.dwg LAYOUT: 9-3 SAVED: 2/19/2015 2:40 PM ACADVER: 18.1S (LMS TECH) PAGES: 18
 I:\arcad\proj\B0045362\IAWP\CTB PLOTTED: 2/19/2015 2:42 PM BY: HUTCHINS-WASS, TABITHA

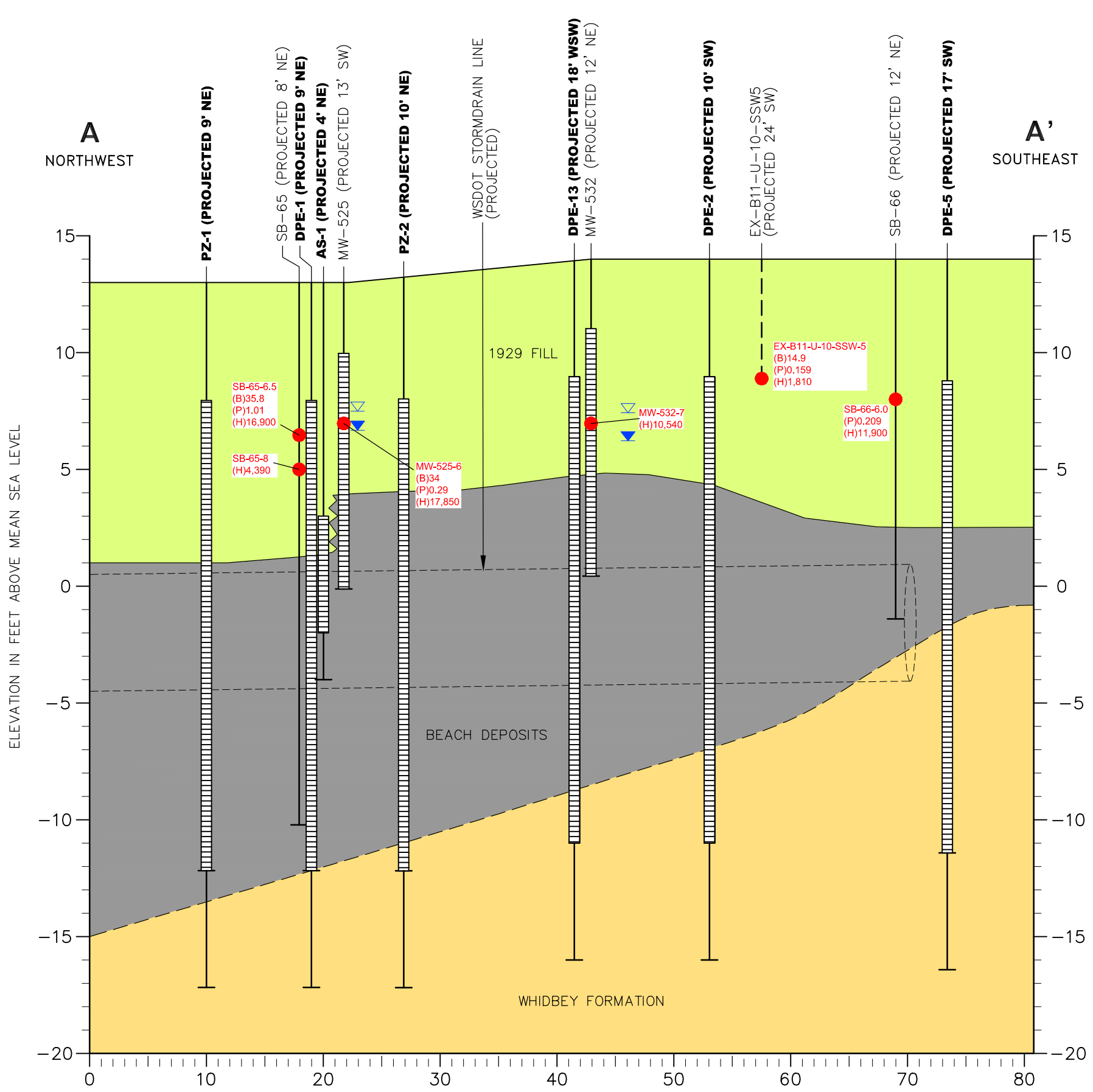

CITY: PHOENIX, AZ DIV/GROUP: ENV/CAD DB: A. REYES, T. HUTCHINS/WASS, J. HARRIS
 C:\Users\jharris\Desktop\ENV\CAD\RETURN-TO-PHONENIX_AZ\B0045362\0000002\AWP\B0045362_V08-X-Seeds.dwg LAYOUT: 9-4 SAVED: 3/31/2015 5:35 PM ACADVER: 19.1.5 (LMS TECH) PAGESETUP: SETUP1 PLOTSTYLETABLE: ARCADIS.CTB PLOTTED: 3/31/2015 5:38 PM BY: HARRIS, JESSICA

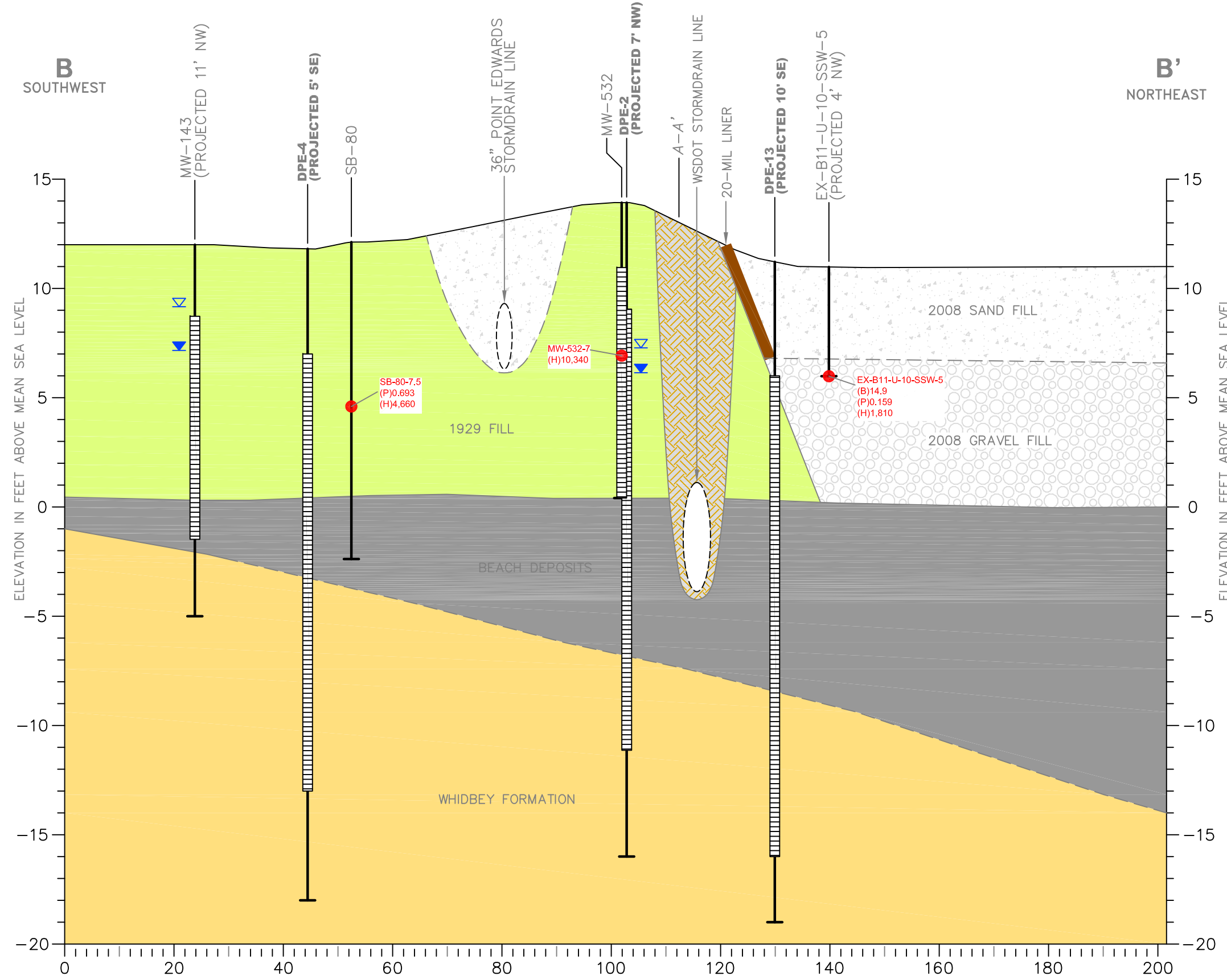

- LEGEND:**
- WELL OR BORING ID, PROJECTED DISTANCE AND DIRECTION
(BOLD REPRESENTS PROPOSED AS/DPE WELLS)
 - GROUND SURFACE
 - HISTORICAL HIGH WATER LEVEL
 - HISTORICAL LOW WATER LEVEL
 - LITHOLOGIC CONTACT (DASHED WHERE INFERRED)
 - SAMPLE ID AND DEPTH
 B = BENZENE (mg/kg)
 P = TOTAL cPAHs (mg/kg)
 H = TOTAL HYDROCARBONS (mg/kg)
 - SCREENED INTERVAL
 - BOTTOM OF BORING
 - DISTURBED TRENCH MATERIAL
 - 1929 FILL MATERIAL
 - BEACH DEPOSITS
 - WHIDBEY FORMATION
 - 2007/2008 FILL (GRAVEL)
 - 2007/2008 FILL (SILT, SAND AND GRAVEL)
 - cPAH CARCINOGENIC POLYNUCLEAR AROMATIC HYDROCARBONS, ADJUSTED FOR TOXICITY
 - mg/kg MILLIGRAMS PER KILOGRAM
 - NE NORTHEAST
 - SW SOUTHWEST

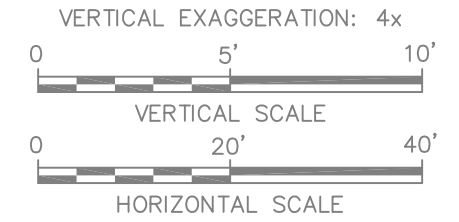

CHEVRON ENVIRONMENTAL MANAGEMENT COMPANY
 FORMER UNOCAL BULK FUEL TERMINAL
 EDMONDS, WASHINGTON
INTERIM ACTION WORK PLAN

DPE CROSS SECTION B-B'

FIGURE
9-4



Appendix A





Selected Data from Previous Investigations

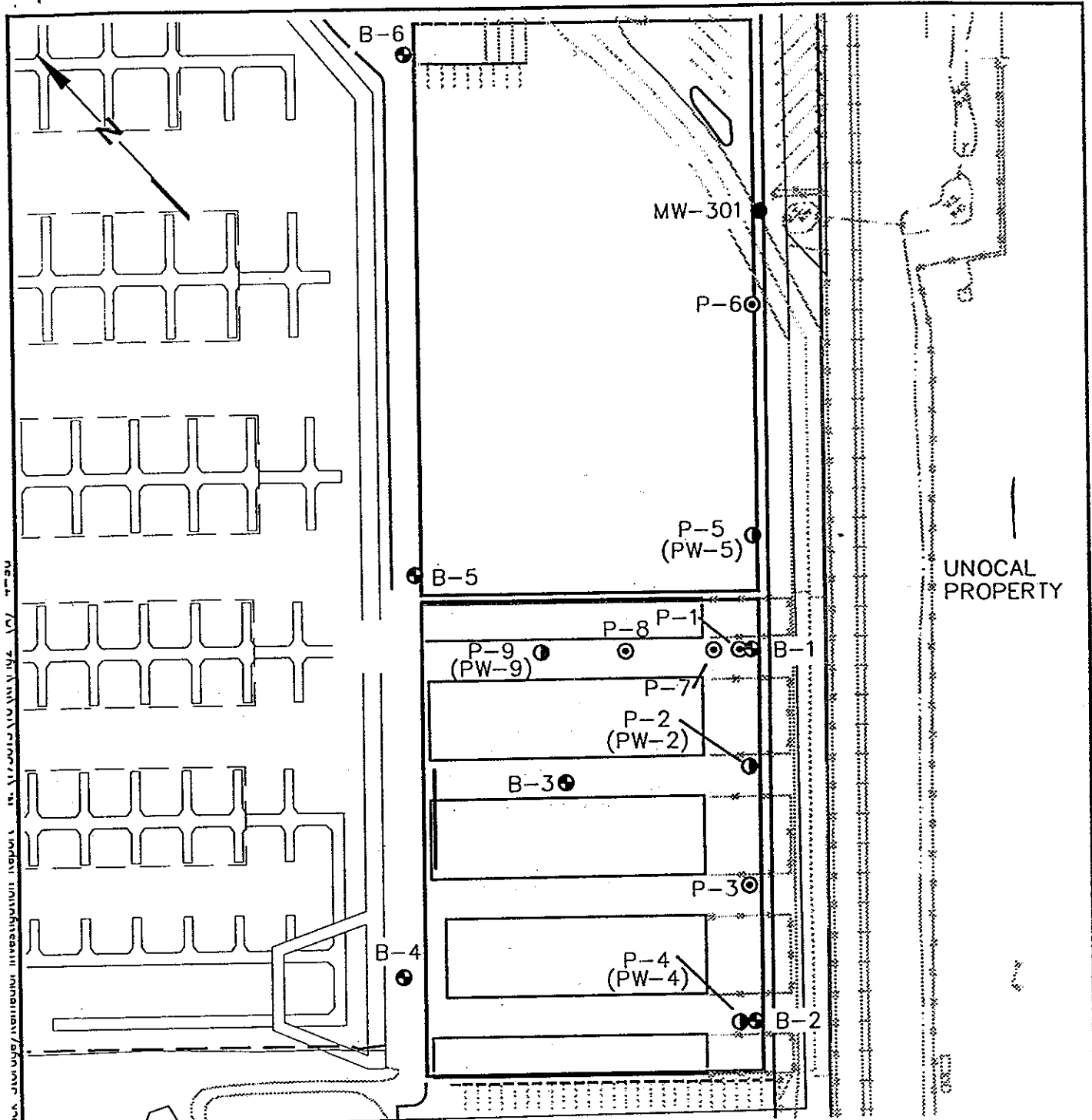

Landau Associates, Inc. 1998. Petroleum Hydrocarbon Investigations, South Marina, Port of Edmonds, Washington. April 8, 1998



Key

- 
Approximate Geotechnical Boring Location and Identification (March 4, 1996)
 B-1
- 
Approximate Soil Sample Location and Identification (November 10, 1997)
 P-1
- 
Approximate Soil and Groundwater Sample Location and Identification (November 10, 1997)
 P-2 (PW-2)
- 
Monitoring Well Installed by Unocal (1997)
 MW-301

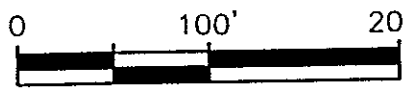

Scale in Feet



Exploration Locations

Figure 2

TABLE 1
SOIL ANALYSIS RESULTS
PROPOSED DRY STACK STORAGE FACILITY (mg/kg, ppm)

Sample ID (depth)	Diesel Range	Motor Oil Range
Method blank	5.0 U	10 U
P-1 S-2 5.9' - 6.3'	1,100	2,200
P-1 S-3 8.6' - 9'	17,000	20,000
P-2 S-3 9.7' - 10'	450	740
P-3 S-3 9.5' - 10'	69	140
P-4 S-3 9.2' - 9.8'	5.5 U	11 U
P-5 S-3 9.0' - 10.0'	120	250
P-6 S-3 9.0' - 10.0'	5.4 U	11 U
P-7 S-2 6.0' - 6.75'	5.3 U	11 U
P-7 S-3 8.5' - 9.5'	16,000	16,000
P-7 S-4 12.0' - 12.75'	9,800	10,000
P-8 S-3 8.5' - 9.2'	15,000	15,000
P-8 S-4 12.0' - 12.75'	590	530
P-9 S-3 9.0' - 10.0'	5.5 U	11 U
P-9 S-4 11.25' - 12.0'	6.6	12
P-9 S-4 deep	6.2	12

TABLE 2
GROUNDWATER ANALYSIS RESULTS
PROPOSED DRY STACK STORAGE FACILITY (mg/L, ppm)

Sample ID (depth)	Diesel Range	Motor Oil Range
Method blank	0.25 U	0.50 U
PW-2 9.0'	13	11
PW-4 9.0'	0.26	0.50 U
PW-5 8.5'	0.92	1.0
PW-9 9.25'	0.44	0.50 U



EMCON. 1998. Remedial Investigation Report, Unocal
Edmonds Bulk Fuel Terminal. October 19, 1998

Table 2-1

**Soil Petroleum Hydrocarbon Data
UNOCAL Edmonds Bulk Fuel Terminal**

Page 2 of 7

Location Number	Date Sampled	Depth Sampled (feet)	TPH as Gasoline ^a	TPH as Diesel ^a	TPH-IR ^b	Benzene ^c	Toluene ^c	Ethylbenzene ^c	Total Xylenes ^c
General Lower Yard									
HA-24	04/30/91	1.0	14	160	3,100	—	—	—	—
HA-25 ^f	04/30/91	2.0	<10	1,200	11,000	—	—	—	—
HA-101A	12/23/92	2.5	<5J	<25 ^d	—	<0.05J	<0.1J	<0.1J	<0.1J
HA-102A	12/23/92	2.0	<5J	<25 ^d	—	<0.05J	<0.1J	<0.1J	<0.1J
LM-1	4/17/89	3.0	—	—	260	—	—	—	—
LM-1	4/17/89	8.0	—	—	120	—	—	—	—
LM-2	4/17/89	1.5	—	—	65	—	—	—	—
LM-3	4/17/89	2.0	—	—	360	—	—	—	—
MW-27-1 (BNRR)	05/03/91	2.5	<5	<5	<5	—	—	—	—
MW-27-3 (BNRR)	05/03/91	12.5	<5	<5	—	<0.025	<0.025	<0.025	<0.025
MW-28-2 (BNRR)	05/03/91	7.5	<5	<5	<5	—	—	—	—
MW-28-3 (BNRR)	05/03/91	12.5	<5	<5	—	<0.025	<0.025	<0.025	<0.025
MW-29-2 (BNRR)	05/03/91	7.5	<5	<5	<5	—	—	—	—
MW-29-3 (BNRR)	05/03/91	12.5	<5	<5	—	<0.025	<0.025	<0.025	<0.025
MW-101B	12/22/92	5.5	<5J	<25 ^d	—	<0.05J	<0.1J	<0.1J	<0.1J
MW-101C	12/22/92	8.0	43J	<25 ^d	—	<0.05J	0.1J	0.3J	0.8J
MW-102B	12/22/92	6.0	<5J	<25 ^d	—	<0.05J	<0.1J	<0.1J	<0.1J
MW-102C	12/22/92	8.0	2.7J	2,360* ^d	—	<0.05J	3.7J	5.1J	33.6J
MW-103B	12/22/92	6.0	<5J	2,670J* ^d	—	<0.05J	<0.1J	<0.1J	<0.1J
MW-103C	12/22/92	8.0	<5J	<25 ^d	—	<0.05J	<0.1J	<0.1J	<0.1J
MW-104A	12/22/92	5.0	<5J	<25 ^d	—	<0.05J	<0.1J	<0.1J	<0.1J
MW-104B	12/22/92	7.5	<5J	<25 ^d	—	<0.05J	<0.1J	<0.1J	<0.1J
TP-5	09/90	2.0	<5	180	530	<0.025	<0.025	<0.025	<0.025

**Table 5-1
TPH and BTEX in Soil
Admiral Way Borings
UNOCAL Edmonds Terminal**

SITE	DATE	DEPTH	TPH - DRO (mg/kg)	TPH - HO (mg/kg)	TPH - GRO (mg/kg)	Benzene (mg/kg)	Ethylbenzene (mg/kg)	Toluene (mg/kg)	Total xylenes (mg/kg)
SB-1	08/23/01	3.5	<10.0	<25.0	<5.00	<0.0300	<0.0500	<0.0500	<0.100
SB-1	08/23/01	6	2190 J	<275	366 J	<0.120 J	0.348 J	<0.200 J	1.05 J
SB-2	08/23/01	6	88.4	84.5	<5.00	<0.0300	<0.0500	<0.0500	<0.100
SB-3	08/24/01	7	15.1	43.8	<5.00	<0.0300	<0.0500	<0.0500	<0.100
SB-4	08/23/01	3.5	<10.0 J	<25.0 J	<5.00 J	<0.0300 J	<0.0500 J	<0.0500 J	<0.100 J
SB-4	08/23/01	6	2010	1190	<5.00	<0.0300	<0.0500	<0.0500	<0.100
SB-5	08/24/01	7	<10.0	<25.0	<5.00	<0.0300	<0.0500	<0.0500	<0.100
SB-6	08/24/01	5	82.3 J	159 J	<5.00 J	<0.0300 J	<0.0500 J	<0.0500 J	<0.100 J
SB-7	08/24/01	5	<10.0	<25.0	<5.00	<0.0300	<0.0500	<0.0500	<0.100

Values represent total concentration unless noted. < = Not detected at indicated reporting limit. --- = Not analyzed. J = Estimated result.

**Table 5-2
PAHs in Soil
Admiral Way Borings
UNOCAL Edmonds Terminal**

CONSTITUENT	(Units in mg/kg)	SITE DATE	DEPTH (ft)	SB-1	SB-1	SB-2	SB-3	SB-4	SB-4	SB-5	SB-6	SB-7
				8/23/01	8/23/01	8/23/01	8/24/01	8/23/01	8/23/01	8/24/01	8/24/01	8/24/01
1-Methylnaphthalene			3.5	<0.200	1.68	<0.200	<0.200	<0.100 J	<0.200	<0.100	<0.200	<0.100
2-Methylnaphthalene			6	<0.200	1.13	<0.200	<0.200	<0.100 J	<0.200	<0.100	<0.200	<0.100
Acenaphthene			3.5	<0.0200	0.352	0.0238	<0.0100	<0.0100 J	0.154	<0.0100	<0.0200	<0.0100
Acenaphthylene			6	<0.0200	<0.0200	<0.0200	<0.0100	<0.0100 J	<0.0200	<0.0100	<0.0200	<0.0100
Anthracene			7	<0.0200	<0.0200	0.0409	<0.0100	0.011 J	0.373	<0.0100	<0.0200	<0.0100
Benzo(a)anthracene			3.5	<0.0200	0.0978	0.0426	<0.0100	0.0378 J	0.721	<0.0100	0.0406	<0.0100
Benzo(a)pyrene			6	<0.0200	0.0349	0.0358	<0.0100	0.0549 J	0.305	<0.0100	0.0469	<0.0100
Benzo(b)fluoranthene			7	<0.0200	0.0559	0.0613	<0.0100	0.057 J	0.315	<0.0100	0.0734	<0.0100
Benzo(ghi)perylene			5	<0.0200	<0.0200	0.0375	<0.0100	0.0364 J	0.194	<0.0100	0.0687	<0.0100
Benzo(k)fluoranthene			5	<0.0200	<0.0200	<0.0200	<0.0100	0.0124 J	0.048	<0.0100	<0.0200	<0.0100
Chrysene				<0.0200	0.0992	0.0562	<0.0100	0.0343 J	0.803	<0.0100	0.0625	<0.0100
Dibenzo(a,h)anthracene				<0.0200	<0.0200	<0.0200	<0.0100	0.022 J	<0.0200	<0.0100	0.0593	<0.0100
Fluoranthene				<0.0200	0.299	0.177	<0.0100	0.0735 J	1.16	<0.0100	0.0765	<0.0100
Fluorene				<0.0200	0.939	0.0324	<0.0100	<0.0100 J	0.374	<0.0100	<0.0200	<0.0100
Indeno(1,2,3-cd)pyrene				<0.0200	0.0559	0.08	<0.0100	0.059 J	0.166	<0.0100	0.106	<0.0100
Naphthalene				0.0307	0.0796	0.0272	<0.0100	<0.0100 J	<0.0200	<0.0100	<0.0200	<0.0100
Phenanthrene				<0.0200	1.07	0.0851	<0.0100	0.0391 J	1.42	<0.0100	0.0234	<0.0100
Pyrene				<0.0200	0.314	0.155	<0.0100	0.0851 J	1.41	<0.0100	0.0718	<0.0100

Values represent total concentration unless noted.
 < = Not detected at indicated reporting limit.
 --- = Not analyzed.
 J = Estimated result.



Maul Foster & Alongi, Inc. 2003b. Draft
Supplemental Remedial Investigation Report,
Unocal Edmonds Terminal, Edmonds, Washington.
April 28, 2003. SIT3.12

File: \9077\01.05\006-5-3.DWG Last edited: APR 24, 2003 by: btookee Xrefs: wells Black/White

LEGEND:

Sample Depth (in feet below ground surface)	TPH (as gasoline or gasoline-range) (mg/kg)	TPH (as diesel or diesel-range) (mg/kg)	TPH (as oil or heavy oil) (mg/kg)
0.0	0	0	0
2.5	0	0	0
5.0	0	0	0
7.5	0	0	0
10	0	0	0

U = NOT DETECTED AT OR ABOVE THE METHOD REPORTING LIMIT.

CONCENTRATIONS IN mg/kg.

NOTES:

- 1) P-1 THROUGH P-9 DATA WERE COLLECTED BY LANDAU ASSOCIATES, INC. IN NOVEMBER 1997.
- 2) MW-27 THROUGH MW-29 DATA WERE COLLECTED BY GEOENGINEERS IN 1991.
- 3) SB-100 SERIES AND MW-100 SERIES DATA WERE COLLECTED BY EMCON IN 1995.
- 4) SB-1 THRU SB-7 AND TP-4 THRU TP-20 DATA WERE COLLECTED BY MFA IN 2001.

- Property Boundary
- Test Pit
- Soil Boring
- ⊕ Monitoring Well/Boring
- ⊘ Abandoned Monitoring Well/Boring

PORT OF EDMONDS

LOWER YARD

ADMIRAL WAY

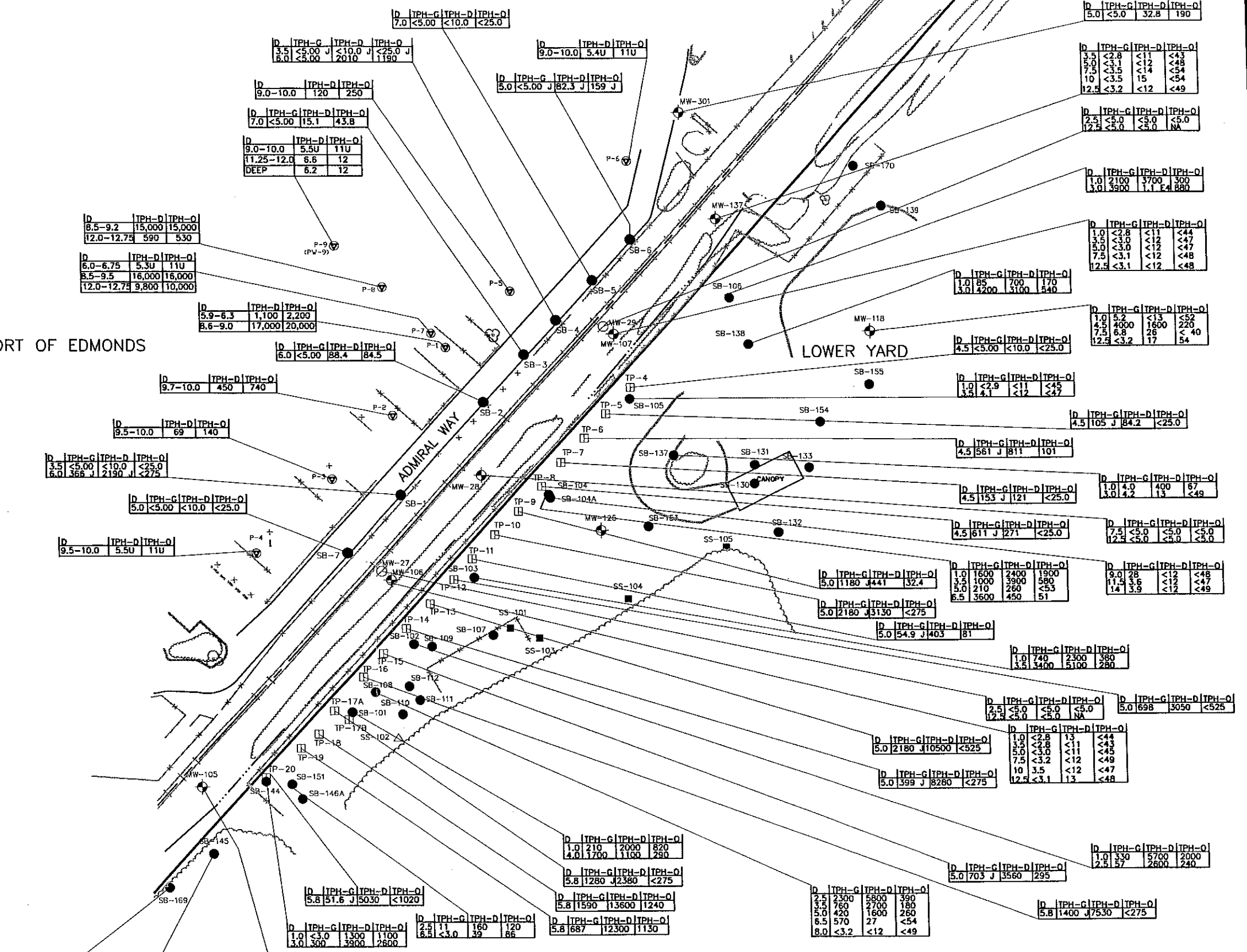
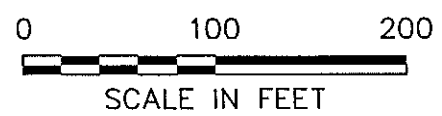

Vancouver: (360) 694-2691
 Edmonds: (425) 744-1489
 Portland: (971) 544-2139

**MAUL
FOSTER
ALONGI**

DATE 04/03
 DWN. BDT
 APPR. _____
 REVIS. _____
 PROJECT NO.
 9077.01.05

FIGURE 5-3
 UNOCAL EDMONDS TERMINAL
 EDMONDS, WASHINGTON
 TPH IN SOIL
 SOUTHWEST LOWER YARD,
 ADMIRAL WAY, PORT OF EDMONDS

File: \9077\01.05\006-5-4.DWG Last edited: APR 22, 2003 by: bitookey Xrefs: none black/white

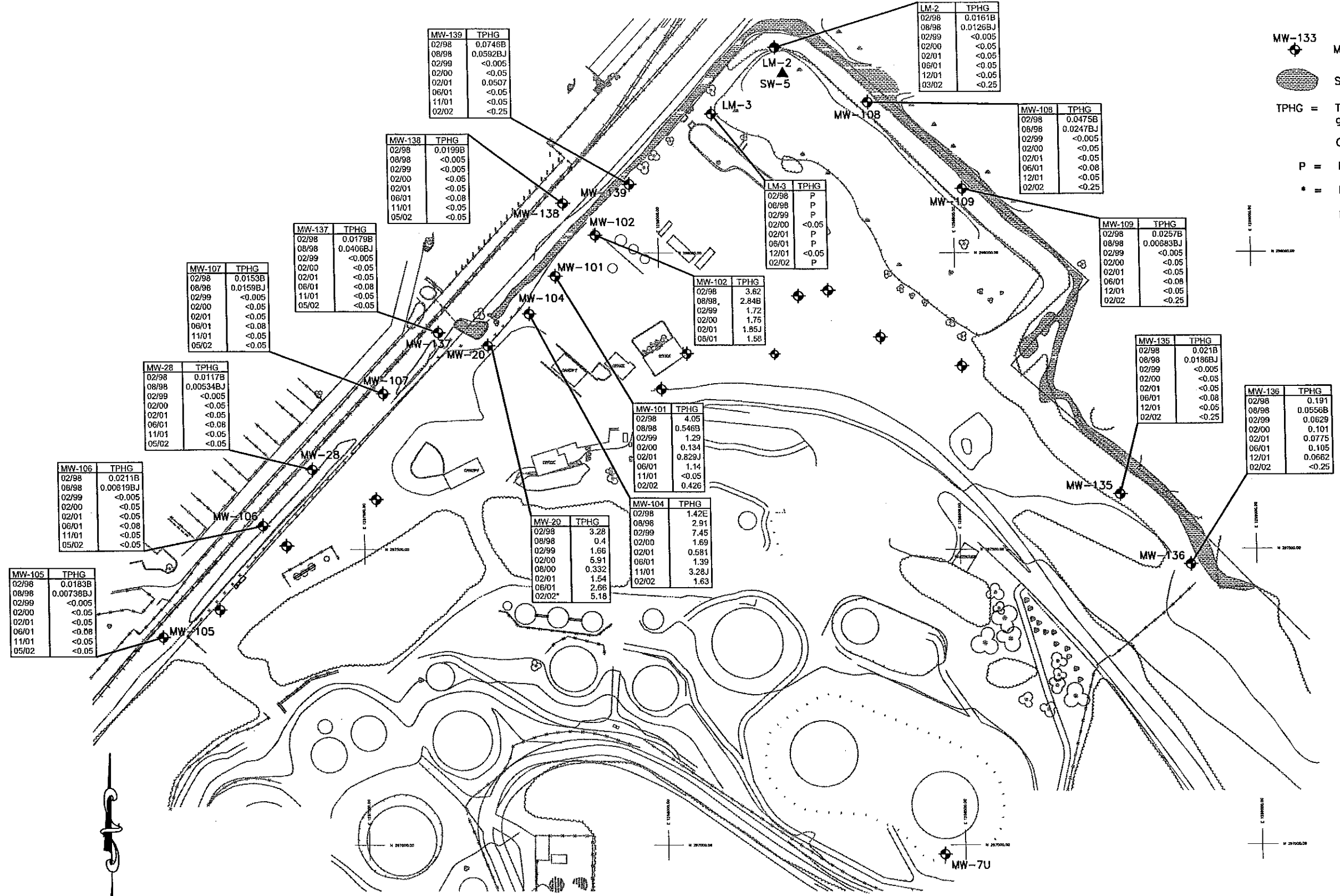
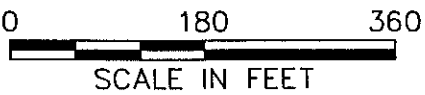

Legend

- MW-133 Monitoring Well
- Surface Water
- TPHG = Total Petroleum Hydrocarbons in the gasoline range
Concentrations in mg/L
- P = Product in well; sample not collected
- * = Result is from replacement well MW-20R

NOTE:
The method reporting limit for NWTPH-G_x is 0.25 mg/L.

MW-105	TPHG
02/98	0.0183B
08/98	0.00738BJ
02/99	<0.005
02/00	<0.05
02/01	<0.05
06/01	<0.08
11/01	<0.05
05/02	<0.05

MW-106	TPHG
02/98	0.0211B
08/98	0.00619BJ
02/99	<0.005
02/00	<0.05
02/01	<0.05
06/01	<0.08
11/01	<0.05
05/02	<0.05

MW-28	TPHG
02/98	0.0117B
08/98	0.00534BJ
02/99	<0.005
02/00	<0.05
02/01	<0.05
06/01	<0.08
11/01	<0.05
05/02	<0.05

MW-107	TPHG
02/98	0.0153B
08/98	0.0159BJ
02/99	<0.005
02/00	<0.05
02/01	<0.05
06/01	<0.08
11/01	<0.05
05/02	<0.05

MW-137	TPHG
02/98	0.0179B
08/98	0.0406BJ
02/99	<0.005
02/00	<0.05
02/01	<0.05
06/01	<0.08
11/01	<0.05
05/02	<0.05

MW-138	TPHG
02/98	0.0199B
08/98	<0.005
02/99	<0.005
02/00	<0.05
02/01	<0.05
06/01	<0.08
11/01	<0.05
05/02	<0.05

MW-139	TPHG
02/98	0.0746B
08/98	0.0592BJ
02/99	<0.005
02/00	<0.05
02/01	0.0507
06/01	<0.05
11/01	<0.05
02/02	<0.25

MW-20	TPHG
02/98	3.28
08/98	0.4
02/99	1.66
02/00	5.91
08/00	0.332
02/01	1.54
06/01	2.66
02/02*	5.18

MW-104	TPHG
02/98	1.42E
08/98	2.91
02/99	7.45
02/00	1.69
02/01	0.681
06/01	1.39
11/01	3.28J
02/02	1.63

MW-101	TPHG
02/98	4.05
08/98	0.546B
02/99	1.29
02/00	0.134
02/01	0.829J
06/01	1.14
11/01	<0.05
02/02	0.426

MW-102	TPHG
02/98	3.62
08/98	2.84B
02/99	1.72
02/00	1.75
02/01	1.85J
06/01	1.58

LM-3	TPHG
02/98	P
08/98	P
02/99	P
02/00	<0.05
02/01	P
06/01	P
12/01	<0.05
02/02	P

LM-2	TPHG
02/98	0.0161B
08/98	0.0126BJ
02/99	<0.005
02/00	<0.05
02/01	<0.05
06/01	<0.05
12/01	<0.05
03/02	<0.25

MW-108	TPHG
02/98	0.0475B
08/98	0.0247BJ
02/99	<0.005
02/00	<0.05
02/01	<0.05
06/01	<0.08
12/01	<0.05
02/02	<0.25

MW-109	TPHG
02/98	0.0257B
08/98	0.00683BJ
02/99	<0.005
02/00	<0.05
02/01	<0.05
06/01	<0.08
12/01	<0.05
02/02	<0.25

MW-135	TPHG
02/98	0.021B
08/98	0.0186BJ
02/99	<0.005
02/00	<0.05
02/01	<0.05
06/01	<0.08
12/01	<0.05
02/02	<0.25

MW-136	TPHG
02/98	0.191
08/98	0.0556B
02/99	0.0629
02/00	0.101
02/01	0.0775
06/01	0.105
12/01	0.0662
02/02	<0.25

Vancouver: (360) 694-2691
Edmonds: (425) 744-1489
Portland: (971) 544-2139

**MAUL
FOSTER
ALONGI**

DATE 04/03
DWN. BDT
APPR. _____
REVIS. _____
PROJECT NO. 9077.01.05

FIGURE 5-4
UNOCAL EDMONDS TERMINAL
EDMONDS, WASHINGTON
TPH-G/GRO IN GROUNDWATER
PERIMETER MONITORING WELL NETWORK
1998 - 2002



Landau Associates, Inc. 2004. Petroleum Hydrocarbon Investigations, South Marina Dry Stack Storage Facility, Port of Edmonds, Washington. June 24, 2004

Port of Edmonds\South Marina\T:\173\02011\08\01\Fig_2_0242004

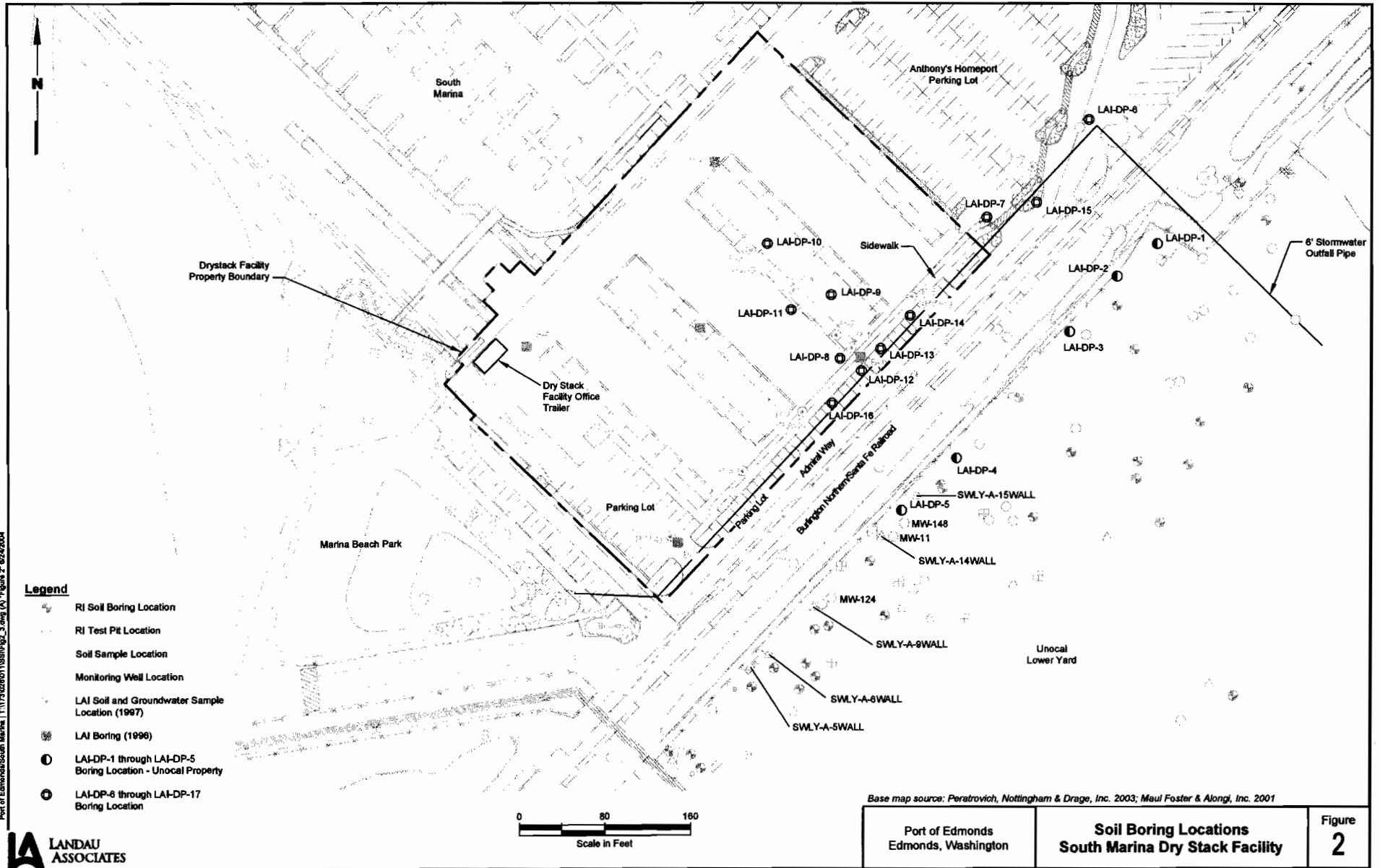

Legend

- RI Soil Boring Location
- RI Test Pit Location
- Soil Sample Location
- Monitoring Well Location
- LAI Soil and Groundwater Sample Location (1987)
- LAI Boring (1996)
- LAI-DP-1 through LAI-DP-5 Boring Location - Unocal Property
- LAI-DP-6 through LAI-DP-17 Boring Location



Base map source: Peratovich, Nottingham & Drage, Inc. 2003; Maul Foster & Alongi, Inc. 2001

Port of Edmonds Edmonds, Washington	Soil Boring Locations South Marina Dry Stack Facility	Figure 2
--	--	---------------------

TABLE 1
SOIL ANALYTICAL RESULTS
SOUTH MARINA DRY STACK STORAGE FACILITY

	MTCA Method A Soil Cleanup Levels for Unrestricted Land Uses	LAI-DP-1 7-8 ft BGS B4E0395-01 5/11/2004	LAI-DP-2 4.5-6 ft BGS B4E0395-02 5/11/2004	LAI-DP-3 3.5-4.5 ft BGS B4E0395-03 5/11/2004	LAI-DP-4 6-8 ft BGS B4E0395-04 5/11/2004	LAI-DP-5 7-8 ft BGS B4E0395-05 5/11/2004	LAI-DP-6 8-10 ft BGS B4E0395-06 5/11/2004	LAI-DP-7 9-11 ft BGS B4E0395-07 5/11/2004	LAI-DP-8 14-16 ft BGS B4E0395-08 5/11/2004	LAI-DP-9 10-12 ft BGS B4E0395-09 5/11/2004
GASOLINE AND BTEX (mg/kg)										
NWTPH-G/EPA 8021B										
Gasoline	30	NA	1580	5.00 U	7680 J (a)	5.00 U	NA	NA	46.8 (b)	225 J (b)
Benzene	0.03	NA	1.54 J	0.0300 U	2.25 J (a)	0.0300 U	NA	NA	0.0300 U	0.120 U
Toluene	7	NA	2.42 J (a)	0.0500 U	8.86	0.0500 U	NA	NA	0.0500 U	0.200 U
Ethylbenzene	6	NA	2.54 J	0.0500 U	33.9	0.0500 U	NA	NA	0.0500 U	0.350 J (a)
Xylenes (total)	9	NA	3.72 J (a)	0.100 U	61.4	0.100 U	NA	NA	0.116 J (a)	1.11 J (a)
NWTPH-Dx (mg/kg)										
Diesel-Range Hydrocarbons	2000	10.0 U	4440	10.0 U	788 (c)	10.0 U	71.9	105	5450	14800
Lube Oil-Range Hydrocarbons	2000	25.0 U	570	25.0 U	1000 U	25.0 U	196	217	5170	14600
cPAHs (mg/kg)										
8270-SIM										
Benzo(a)anthracene		NA	0.0613 J	NA	0.0483	NA	NA	NA	0.152	NA
Benzo(a)pyrene		NA	0.0288 J	NA	0.0257	NA	NA	NA	0.114	NA
Benzo(b)fluoranthene		NA	0.0140 J	NA	0.0294	NA	NA	NA	0.159	NA
Benzo(k)fluoranthene		NA	0.0100 U	NA	0.0226	NA	NA	NA	0.100 U	NA
Chrysene		NA	0.119 J	NA	0.0506	NA	NA	NA	0.561	NA
Dibenz(a,h)anthracene		NA	0.0185 J	NA	0.0128	NA	NA	NA	0.144	NA
Indeno(1,2,3-cd)pyrene		NA	0.0111 J	NA	0.0113	NA	NA	NA	0.100 U	NA
cPAH TEQ (mg/kg)	0.1	NA	0.046	NA	0.042	NA	NA	NA	0.208	NA
DRY WEIGHT (%)		85.0	90.6	85.4	89.8	92.2	86.5	82.7	87.3	93.9

TABLE 1
SOIL ANALYTICAL RESULTS
SOUTH MARINA DRY STACK STORAGE FACILITY

	MTCA Method A Soil Cleanup Levels for Unrestricted Land Uses	LAI-DP-9B	LAI-DP-10	LAI-DP-11	LAI-DP-12	LAI-DP-13	LAI-DP-14	LAI-DP-16	LAI-DP-16B
		10-12 ft BGS B4E0395-10 5/11/2004	12-16 ft BGS B4E0395-11 5/12/2004	10.5-12 ft BGS B4E0395-12 5/12/2004	10-12 ft BGS B4E0395-13 5/12/2004	9-11 ft BGS B4E0395-14 5/12/2004	9-11 ft BGS B4E0395-15 5/12/2004	9-11 ft BGS B4E0395-16 5/12/2004	9-11 ft BGS B4E0395-17 5/12/2004
GASOLINE AND BTEX (mg/kg)									
NWTPH-G/EPA 8021B									
Gasoline	30	268 J (b)	NA	NA	94.8 (b)	NA	NA	104 (b)	55.0 (b)
Benzene	0.03	0.120 U	NA	NA	0.0300 U	NA	NA	0.0300 U	0.0435
Toluene	7	0.200 U	NA	NA	0.0500 U	NA	NA	0.0500 U	0.0500 U
Ethylbenzene	6	0.285 J (a)	NA	NA	0.0507 J (a)	NA	NA	0.0500 U	0.0500 U
Xylenes (total)	9	1.03 J (a)	NA	NA	0.290 J (a)	NA	NA	0.339 J (a)	0.239 J (a)
NWTPH-Dx (mg/kg)									
Diesel-Range Hydrocarbons	2000	11100	10.0 U	17900	1680	595	200	955	1000
Lube Oil-Range Hydrocarbons	2000	9840	25.0 U	16100	1850	833	353	1050	1180
cPAHs (mg/kg)									
8270-SIM									
Benzo(a)anthracene		NA	NA	NA	NA	NA	NA	NA	NA
Benzo(a)pyrene		NA	NA	NA	NA	NA	NA	NA	NA
Benzo(b)fluoranthene		NA	NA	NA	NA	NA	NA	NA	NA
Benzo(k)fluoranthene		NA	NA	NA	NA	NA	NA	NA	NA
Chrysene		NA	NA	NA	NA	NA	NA	NA	NA
Dibenz(a,h)anthracene		NA	NA	NA	NA	NA	NA	NA	NA
Indeno(1,2,3-cd)pyrene		NA	NA	NA	NA	NA	NA	NA	NA
cPAH TEQ (mg/kg)	0.1	NA	NA	NA	NA	NA	NA	NA	NA
DRY WEIGHT (%)		92.4	80.7	95.5	87.1	89.3	83.5	92.3	88.7

(a) As reported by the laboratory, the analyte concentration may be artificially elevated due to coeluting compounds or components.

(b) As reported by the laboratory, results reported for the gas range are primarily due to overlap from diesel range hydrocarbons.

(c) As reported by the laboratory, the sample chromatographic pattern does not resemble the fuel standard used for quantitation.

BGS = Below ground surface.

NA = Not analyzed.

U = Indicates the compound was undetected at the reported concentration.

J = Data validation flag indicating the analyte was positively identified; the associated numerical value is the approximate concentration of the analyte in the sample.

Box indicates exceedance of soil cleanup level.

DRAFT

North Creek Analytical Summary Memorandum: Chromatograph Comparison

Memorandum

To: David Nelson, Landau Associates
CC: Jeannie Garthwaite; Brad Meadows
From: Katharine Nunn
Date: 6/24/2004
Re: Work Order B4E0495 Chromatogram comparison

I compared the diesel analysis chromatograms for B4E0495-02 (DP-2-4.5-6) to the other samples in the work order per your request. The table below shows what I found:

Lab Sample ID	Client Sample ID	Contamination Type
B4E0395-01	DP-1-7-8	No discernable contamination
B4E0395-02	DP-2-4.5-6	Mixture of jet fuel (not the same as jet fuel in 395-04) and diesel
B4E0395-03	DP-3-3.5-4.5	No discernable contamination
B4E0395-04	DP-4-6-8	Appears to be jet fuel – possibly JP-5
B4E0395-05	DP-5-7-8	No discernable contamination
B4E0395-06	DP-6-8-10	Appears to be a mixture of hydrocarbons possibly weathered diesel and motor oil
B4E0395-07	DP-7-9-11	Appears to be a mixture of hydrocarbons possibly weathered diesel and motor oil
B4E0395-08	DP-8-14-16	Appears to be a mixture of hydrocarbons possibly weathered diesel and motor oil
B4E0395-09	DP-9-10-12	Appears to be a mixture of hydrocarbons possibly weathered diesel and motor oil
B4E0395-10	DP-9B-10-12	Appears to be a mixture of hydrocarbons possibly weathered diesel and motor oil
B4E0395-11	DP-10-12-16	Appears to be a mixture of hydrocarbons possibly weathered diesel and motor oil
B4E0395-12	DP-11-10.5-12	Appears to be a mixture of hydrocarbons possibly weathered diesel and motor oil
B4E0395-13	DP-11-10.5-12	Appears to be a mixture of hydrocarbons possibly weathered diesel and motor oil
B4E0395-14	DP-13-9-11	Appears to be a mixture of hydrocarbons possibly weathered diesel and motor oil
B4E0395-15	DP-14-9-11	Appears to be a mixture of hydrocarbons possibly weathered diesel and motor oil
B4E0395-16	DP-16-9-11	Appears to be a mixture of hydrocarbons possibly weathered diesel and motor oil
B4E0395-17	DP-16B-9-11	Appears to be a mixture of hydrocarbons possibly weathered diesel and motor oil

I compared the Gas/BTEX analysis chromatograms for B4E0495-04 (DP-4-6-8) to the other samples in the work order per your request. I don't have as many standards run by purge and trap – so I can't give you as much information as the diesel range. Here's the information I can give:

Lab Sample ID	Client Sample ID	Similarity to B4E0395-04 (DP-4-6-8)
B4E0395-02	DP-2-4.5-6	Appears to contain some of the same components
B4E0395-03	DP-3-3.5-4.5	No discernable contamination
B4E0395-05	DP-5-7-8	No discernable contamination
B4E0395-08	DP-8-14-16	Hydrocarbon pattern is completely different and elutes later
B4E0395-09	DP-9-10-12	Hydrocarbon pattern is completely different and elutes later
B4E0395-10	DP-9B-10-12	Hydrocarbon pattern is completely different and elutes later
B4E0395-13	DP-11-10.5-12	Hydrocarbon pattern is completely different and elutes later
B4E0395-16	DP-16-9-11	Hydrocarbon pattern is completely different and elutes later
B4E0395-17	DP-16B-9-11	Hydrocarbon pattern is completely different and elutes later

I hope this information helps. Please feel free to call me with any questions you have or if you would like me to look at anything else. My direct number is 425-420-9224.



SLR International Corp. 2006. Groundwater Sampling Report – Fall 2006 Sampling Event, Unocal Edmonds Terminal. Edmonds, Washington. November 22, 2006

Table 4
Groundwater Sample Analytical Results - All Events
TPH, Benzene, Total Dissolved cPAH, and Dissolved Arsenic Concentrations
Unocal Edmonds Terminal

Location	Sample ID	Date	Gasoline Range Hydrocarbons ^a (µg/L)	Diesel Range Hydrocarbons ^b (µg/L)	Heavy Oil Range Hydrocarbons ^b (µg/L)	TPH ^c (µg/L)	Benzene ^d (µg/L)	Total Dissolved cPAHs ^{e,f} (µg/L)	Dissolved Arsenic ^g (µg/L)
Proposed Site Groundwater Cleanup Levels						506/706 ^h	51	0.018	34
Proposed Surface Water Compliance Wells									
MW-148	MW148-0804	8/12/2004	4,900	1,350	<500	8,590	1,288	—	4.34
	MW148-0205	2/10/2005	<50	<250	<500	400 ⁱ	0.64	—	<1.0
	MW148-0805	8/25/2005	258	<250	<500	633	24	—	3.30
	MW148-0206	2/9/2006	<50	<236	<472	379 ^j	<0.50	0.0086 ^j	<1.0
MW-149	MW148-0806	8/29/2006	<100	<236	<472	404 ⁱ	<1.0	0.0085 ^j	<1.0
	MW149-0804	8/12/2004	<50	<250	<500	400 ⁱ	<0.50	—	<1.0
	MW149-0205	2/10/2005	<50	<250	<500	400 ⁱ	<0.50	—	<1.0
	MW149-0805	8/25/2005	<50	<250	<500	400 ⁱ	<0.50	—	0.80
MW-150	MW149-0206	2/9/2006	<50	<236	<472	379 ^j	<0.50	0.0086 ^j	<1.0
	MW149-0806	8/29/2006	<100	<236	<472	404 ⁱ	<1.0	0.0085 ^j	<1.0
	MW150-0804	8/12/2004	<50	<250	<500	400 ⁱ	0.76	—	3.24
	MW150-0205	2/10/2005	<50	<250	<500	400 ⁱ	<0.50	—	<1.0
MW-150	MW150-0805	8/24/2005	<50	<250	<500	400 ⁱ	<0.50	—	3.30
	MW150-0206	2/9/2006	<50	<236	<472	379 ^j	<0.50	0.0086 ^j	<1.0
	MW150-0806	8/29/2006	<100	<236	<472	404 ⁱ	<1.0	0.0085 ^j	2.44
	Off-Site Monitoring Wells								
MW-28	BNRR-MW28-1295	12/4/1995	<100	<240	<710	525 ⁱ	<0.50	—	—
	MW-28-0296	2/21/1996	<100	<240	<710	525 ⁱ	<0.50	—	—
	MW-28-0596	5/14/1996	<100	<250	<750	550 ⁱ	<0.50	—	—
	MW-28-0896	8/14/1996	<100	<240	<710	525 ⁱ	<0.50	—	<0.007
	MW-28-1196	11/5/1996	<100	<240	<710	525 ⁱ	<0.50	—	<0.007
	MW-28-0297	2/25/1997	<50	<250	<750	525 ⁱ	<5.0	—	<0.02
	MW-28-0897	8/12/1997	<50	<250	<500	400 ⁱ	<0.50	—	<0.02 E
	MW-28-0298	2/19/1998	12 B	99.7 B	<92	158	<0.10	—	<0.015
	MW-28-0598	8/26/1998	5.3 BJ	70.5 J	<750	451	<0.10	—	<0.015
	MW-28-0299	2/16/1999	<50	29.1 BJ	<750	429	<0.10	—	<0.10
	MW-28-0200	2/23/2000	<50	<250	<750	525 ⁱ	<0.50	—	0.19
	MW-28-0201	2/7/2001	<50	<250	<750	525 ⁱ	<0.50	—	0.18 U
	MW-28-0601	6/28/2001	<80	<250	<500	415 ⁱ	<0.50	—	0.35 J
	MW-28-1101	11/30/2001	<50	<250	<500	400 ⁱ	<0.50	—	<1.0
	MW-28-0502	5/28/2002	<50	<250	<500	400 ⁱ	<0.50	—	<1.0
	MW-28-0802	8/28/2002	<50	<250	<500	400 ⁱ	<0.50	—	<1.0
	MW-28-0203	2/27/2003	<50	<250	<500	400 ⁱ	<0.50	—	—
	MW-28-0204	2/13/2004	<50	<250	<500	400 ⁱ	<0.50	—	<1.0
	MW28-0804	8/24/2004	<50	<250	<500	400 ⁱ	<0.50	—	<1.0
	MW28-0805	8/24/2005	<50	<250	<500	400 ⁱ	<0.50	—	0.60
	MW28-0206	2/17/2006	<50	<236	<472	379 ^j	<0.50	0.0087 ^j	<1.0
	MW28-0906	9/26/2006	—	<236	<472	—	—	0.0085 ^j	<1.0
	MW28-1006	10/4/2006	<50	—	—	379 ^j	<0.50	—	—

Table 4
Groundwater Sample Analytical Results - All Events
TPH, Benzene, Total Dissolved cPAH, and Dissolved Arsenic Concentrations
Unocal Edmonds Terminal

Location	Sample ID	Date	Gasoline Range Hydrocarbons ^a (µg/L)	Diesel Range Hydrocarbons ^b (µg/L)	Heavy Oil Range Hydrocarbons ^b (µg/L)	TPH ^c (µg/L)	Benzene ^d (µg/L)	Total Dissolved cPAHs ^{e,f} (µg/L)	Dissolved Arsenic ^g (µg/L)
Proposed Site Groundwater Cleanup Levels						506706^h	51	0.018	34
Off-Site Monitoring Wells									
MW-105	MW-105-1295	12/27/1995	<100	680	<710	1,055	<0.50	—	—
	MW-105-1295-Dup	12/27/1995	<100	690	740	1,480	<0.50	—	—
	MW-105-0296	2/21/1996	<100	510	890	1,450	<0.50	—	—
	MW-105-0596	5/14/1996	<100	1,000	1,100	2,150	<0.50	—	—
	MW-105-0896	8/14/1996	<100	620	<710	1,025	<0.50	—	3.30 J
	MW-105-1196	11/5/1996	<100	940	1,000	1,990	<0.50	—	6.0 J
	MW-105-0297	2/25/1997	5.50 BJ	705	<750	1,068	<5.0	—	9.5
	MW-105-0897	8/12/1997	<50	944	<500	1,219	<0.50	—	5.70 E
	MW-105-0298	2/19/1998	18 B	285 B	323	626	<0.10	—	7.95
	MW-105-0298-Dup	2/19/1998	14 B	459 B	443	916	—	—	8.6
	MW-105-0598	8/26/1998	7.40 BJ	87.6 J	95 J	190	<0.10	—	2.86
	MW-105-0299	2/16/1999	<50	52.9 BJ	<750	453	<0.10	—	11.3
	MW-105-0200	2/23/2000	<50	<250	<750	525 ^j	<0.50	—	7.78
	MW-105-0201	2/7/2001	<50	<250	<750	525 ^j	<0.50	—	4.68
	MW-105-0601	6/28/2001	<50	<250	<500	400 ^j	<0.50	—	4.08
	MW-105-1101	11/30/2001	<50	<250	<500	400 ^j	<0.50	—	8.28
	MW-105-0502	5/28/2002	<50	<250	<500	400 ^j	<0.50	—	4.16
	MW-105-0802	8/28/2002	<50	<250	<500	400 ^j	<0.50	—	4.49
	MW-105-0203	2/27/2003	<50	<250	<500	400 ^j	<0.50	—	—
	MW-105-0204	2/13/2004	<50	<250	<500	400 ^j	<0.50	—	7.81
MW105-0804	8/24/2004	<50	<250	<500	400 ^j	<0.50	—	5.11	
MW105-0805	8/24/2005	<50	<250	<500	400 ^j	<0.50	—	5.30	
MW105-0206	2/17/2006	<50	<236	<472	379 ^j	<0.50	0.0087 ^j	8.63	
MW105-0906	9/26/2006	—	<236	<472	—	—	0.017 ^j	6.04	
MW105-1006	10/4/2006	<50	—	—	379 ^j	<0.50	—	—	
MW-106	MW-106-1295	12/27/1995	<100	1,600	<1,300	2,380	<0.50	—	—
	MW-106-0296	2/21/1996	<100	530 E	<710	936	<0.50	—	—
	MW-106-0596	5/14/1996	<100	1,700	1,300	3,960	<0.50	—	—
	MW-106-0896	8/14/1996	<100	1,700	1,000	2,750	<0.50	—	<0.07
	MW-106-1196	11/5/1996	<100	1,200	740	1,990	<0.50	—	<0.007
	MW-106-0297	2/25/1997	11 BJ	2,400	1,520	3,931	<5.0	—	<0.20
	MW-106-0897	8/12/1997	<50	2,100	<500	2,375	<0.50	—	<0.02 E
	MW-106-0298	2/19/1998	21 B	1,750	1,080	2,861	<0.10	—	<0.15
	MW-106-0598	8/26/1998	6.20 BJ	137 J	<750	518	<0.10	—	<0.015
	MW-106-0299	2/16/1999	<50	122 BJ	<750	522	0.22 BJ	—	<0.01

Table 4
Groundwater Sample Analytical Results - All Events
TPH, Benzene, Total Dissolved cPAH, and Dissolved Arsenic Concentrations
Unocal Edmonds Terminal

Location	Sample ID	Date	Gasoline Range Hydrocarbons ^a (µg/L)	Diesel Range Hydrocarbons ^b (µg/L)	Heavy Oil Range Hydrocarbons ^b (µg/L)	TPH ^c (µg/L)	Benzene ^d (µg/L)	Total Dissolved cPAHs ^{e,f} (µg/L)	Dissolved Arsenic ^g (µg/L)
Proposed Site Groundwater Cleanup Levels						506/706 ^h	51	0.018	34
Off-Site Monitoring Wells									
MW-106 (Cont.)	MW-106-0200	2/23/2000	<50	<250	<750	525 ⁱ	<0.50	—	0.16
	MW-106-0201	2/7/2001	<50	<250	<750	525 ⁱ	<0.50	—	<0.34
	MW-106-0601	6/28/2001	<80	257	<500	547	<0.50	—	0.48 J
	MW-106-1101	11/30/2001	<50	<250	<500	400 ⁱ	<0.50	—	<1.0
	MW-106-0502	5/28/2002	<50	<250	<500	400 ⁱ	<0.50	—	<1.0
	MW-106-0802	8/28/2002	<50	<250	<500	400 ⁱ	<0.50	—	<1.0
	MW-106-0203	2/27/2003	<50	<250	<500	400 ⁱ	<0.50	—	—
	MW-106-0204	2/13/2004	<50	<250	<500	400 ⁱ	<0.50	—	<1.0
	MW106-0804	8/24/2004	<50	<250	<500	400 ⁱ	<0.50	—	<1.0
	MW106-0805	8/24/2005	<50	<250	<500	400 ⁱ	<0.50	—	0.40
	MW106-0206	2/17/2006	<50	<236	<472	379 ⁱ	<0.50	0.0087 ^j	<1.0
MW106-0906	9/26/2006	—	<236	<472	—	—	0.017 ^j	<1.0	
MW106-1006	10/4/2006	<50	—	—	379 ⁱ	<0.50	—	—	
MW-107	MW-107-1295	12/27/1995	<100	<240	<710	525 ⁱ	<0.50	—	—
	MW-107-0296	2/21/1996	<100	<240	<710	525 ⁱ	<0.50	—	—
	MW-107-0596	5/14/1996	<100	<250	<740	545 ⁱ	<0.50	—	—
	MW-107-0896	8/14/1996	<100	<240	<720	530 ⁱ	<0.50	—	2.30 J
	MW-107-1196	11/5/1996	<100	<240	<710	525 ⁱ	<0.50	—	<0.007
	MW-107-0297	2/25/1997	34 BJ	252	<750	630	<0.50	—	<0.02
	MW-107-0897	8/12/1997	<50	533	<500	808	<0.50	—	<0.02 E
	MW-107-0298	2/19/1998	15 B	110 B	117	242	<0.10	—	<0.015
	MW-107-0598	8/26/1998	16 BJ	93.1 J	<750	484	<0.10	—	<0.015
	MW-107-0299	2/16/1999	<50	51.6 BJ	<750	452	<0.10	—	<0.01
	MW-107-0200	2/23/2000	<50	<250	<750	525 ⁱ	<0.50	—	<0.0068
	MW-107-0201	2/7/2001	<50	<250	<750	525 ⁱ	<0.50	—	<0.11
	MW-107-0201-Dup	2/7/2001	<50	<250	<750	525 ⁱ	<0.50	—	—
	MW-107-0601	6/28/2001	<80	<250	<500	415 ⁱ	<0.50	—	0.24 J
	MW-107-1101	11/30/2001	<50	<250	<500	400 ⁱ	<0.50	—	<1.0
	MW-107-0502	5/28/2002	<50	<250	<500	400 ⁱ	<0.50	—	<1.0
	MW-107-0802	8/28/2002	<50	<250	<500	400 ⁱ	<0.50	—	2.03
	MW-107-0203	2/27/2003	<50	<250	<500	400 ⁱ	<0.50	—	—
	MW-107-0204	2/13/2004	<50	<250	<500	400 ⁱ	<0.50	—	<1.0
	MW107-0804	8/24/2004	<50	<250	<500	400 ⁱ	<0.50	—	1.34
	MW107-0805	8/24/2005	<50	<250	<500	400 ⁱ	<0.50	—	0.40
MW107-0206	2/17/2006	<50	<236	<472	379 ⁱ	<0.50	0.0087 ^j	<1.0	
MW107-0906	9/26/2006	—	<236	<472	—	—	0.0085 ^j	1.78	
MW107-1006	10/4/2006	<50	—	—	379 ⁱ	<0.50	—	—	

Table 4
Groundwater Sample Analytical Results - All Events
TPH, Benzene, Total Dissolved cPAH, and Dissolved Arsenic Concentrations
Unocal Edmonds Terminal

Location	Sample ID	Date	Gasoline Range Hydrocarbons ^a (µg/L)	Diesel Range Hydrocarbons ^b (µg/L)	Heavy Oil Range Hydrocarbons ^b (µg/L)	TPH ^g (µg/L)	Benzene ^d (µg/L)	Total Dissolved cPAHs ^{e,f} (µg/L)	Dissolved Arsenic ^g (µg/L)
Proposed Site Groundwater Cleanup Levels						506/706^h	51	0.018	34
Off-Site Monitoring Wells									
MW-137	MW-137-1295	12/27/1995	<100	<240	<730	535 ⁱ	<0.50	—	—
	MW-137-0296	2/21/1996	<100	<240	<710	525 ⁱ	<0.50	—	—
	MW-137-0596	5/14/1996	<100	<240	<730	535 ⁱ	<0.50	—	—
	MW-137-0896	8/14/1996	<100	<240	<710	525 ⁱ	<0.50	—	1.20 J
	MW-137-1196	11/5/1996	<100	<250	<740	545 ⁱ	<0.50	—	<0.007
	MW-137-0297	2/25/1997	<50	<250	<750	525 ⁱ	<5.0	—	<0.02
	MW-137-0897	8/12/1997	<50	<250	<500	650 ^j	<0.50	—	2.0 E
	MW-137-0298	2/19/1998	18 B	132 B	139	289	<0.10	—	<0.15
	MW-137-0598	8/26/1998	41 BJ	99.5 J	<750	516	<0.10	—	<0.015
	MW-137-0299	2/17/1999	<50	<250	<750	525 ⁱ	<0.10	—	<0.01
	MW-137-0200	2/23/2000	<50	<250	<750	525 ⁱ	<0.50	—	0.17
	MW-137-0201	2/7/2001	<50	<250	<750	525 ⁱ	<0.50	—	<0.56
	MW-137-0601	6/28/2001	<80	<250	<500	415 ⁱ	<0.50	—	0.29 J
	MW-137-1101	11/30/2001	<50	<250	<500	400 ⁱ	<0.50	—	<1.0
	MW-137-0502	5/28/2002	<50	<250	<500	400 ⁱ	<0.50	—	<1.0
	MW-137-0802	8/28/2002	<50	<250	<500	400 ⁱ	<0.50	—	3.68
	MW-137-0203	2/27/2003	<50	<250	<500	400 ⁱ	<0.50	—	—
	MW-137-0204	2/13/2004	<50	<250	<500	400 ⁱ	<0.50	—	<1.0
	MW137-0804	8/24/2004	<50	<250	<500	400 ⁱ	<0.50	—	7.57
	MW137-0805	8/25/2005	<50	<250	<500	400 ⁱ	<0.50	—	1.40
MW137-0206	2/17/2006	<50	<238	<476	382 ⁱ	<0.50	0.0087 ⁱ	<1.0	
MW137-0906	9/26/2006	—	<236	<472	—	—	0.0085 ⁱ	20.3 JF	
MW137-1006	10/4/2006	<50	—	—	379 ⁱ	<0.5	—	—	
MW-138	MW-138-1295	12/28/1995	<100	<240	<720	530 ⁱ	<0.50	—	—
	MW-138-0296	2/21/1996	<100	<240	<710	525 ⁱ	<0.50	—	—
	MW-138-0596	5/14/1996	<100	<250	<750	550 ⁱ	<0.50	—	—
	MW-138-0896	8/14/1996	<100	<250	<740	545 ⁱ	<0.50	—	<0.007
	MW-138-1196	11/5/1996	<100	<240	<710	525 ⁱ	<0.50	—	<0.07
	MW-138-0897	8/12/1997	<50	<250	<500	400 ⁱ	<0.50	—	<0.02 E
	MW-138-0298	2/19/1998	<20	134 B	233	377	<0.10	—	<0.15
	MW-138-0598	8/26/1998	<50	99.2 J	<750	499	<0.10	—	<0.03
	MW-138-0299	2/17/1999	<50	22.4 BJ	<750	422	<0.10	—	0.69 J
	MW-138-0299-Dup	2/17/1999	<50	<250	<750	525 ⁱ	<0.10	—	0.65 J
	MW-138-0200	2/23/2000	<50	<250	<750	525 ⁱ	<0.50	—	0.43
	MW-138-0201	2/7/2001	<50	<250	<750	525 ⁱ	<0.50	—	<0.83
	MW-138-0601	6/28/2001	<80	<250	<500	415 ⁱ	<0.50	—	1.15
	MW-138-1101	11/30/2001	<50	<250	<500	400 ⁱ	<0.50	—	<1.0
	MW-138-0502	5/28/2002	<50	<250	<500	400 ⁱ	<0.50	—	<1.0

Table 4
Groundwater Sample Analytical Results - All Events
TPH, Benzene, Total Dissolved cPAH, and Dissolved Arsenic Concentrations
Unocal Edmonds Terminal

Location	Sample ID	Date	Gasoline Range Hydrocarbons ^a (µg/L)	Diesel Range Hydrocarbons ^b (µg/L)	Heavy Oil Range Hydrocarbons ^b (µg/L)	TPH ^c (µg/L)	Benzene ^d (µg/L)	Total Dissolved cPAHs ^{e,f} (µg/L)	Dissolved Arsenic ^g (µg/L)
Proposed Site Groundwater Cleanup Levels						506/706 ^h	51	0.018	34
Off-Site Monitoring Wells									
MW-138 (Cont.)	MW-138-0802	8/28/2002	<50	<250	<500	400 ⁱ	<0.50	—	<1.0
	MW-138-0203	2/27/2003	<50	<250	<500	400 ⁱ	<0.50	—	—
	MW-138-0204	2/13/2004	<50	<250	<500	400 ⁱ	<0.50	—	<1.0
	MW138-0804	8/24/2004	<50	<250	<500	400 ⁱ	<0.50	—	2.72
	MW138-0805	8/25/2005	<50	<250	<500	400 ⁱ	<0.50	—	3.20
	MW138-0206	2/17/2006	<50	<238	<476	382 ^j	<0.50	0.0087 ^j	1.20
	MW138-0906	9/26/2006	—	<236	<472	—	—	0.0085 ^j	21.5 JF
	MW138-1006	10/4/2006	<50	—	—	379 ⁱ	<0.50	—	—
<p>Notes:</p> <p>µg/L = Micrograms per liter.</p> <p>Bold values exceed the proposed site cleanup levels.</p> <p>NA = Not available.</p> <p>— = Not analyzed.</p> <p>BJ = Estimated result due to contamination in associated method blank.</p> <p>JD = Estimated result due to sample dilution.</p> <p>E = Analyte concentration exceeds instrument calibration range.</p> <p>JS = Estimated result due to sample matrix interference associated with surrogate recoveries.</p> <p>B = Contamination present in associated method blank.</p> <p>BCR = Result rejected due to contaminant in the associated method blank.</p> <p>R = The sample results are rejected due to serious deficiencies in the ability to analyze the sample and meet quality control criteria. The presence or absence of the analyte cannot be verified.</p> <p>J = The analyte was positively identified; the associated numerical value is estimated.</p> <p>JF = The analyte was positively identified; the associated numerical value is estimated due to uncertainty about whether the laboratory filtered the sample.</p> <p>UJ = The analyte was not detected; the results may be biased low due to a low bias in the internal laboratory standard.</p> <p>UJS = The analyte was not detected; result may be biased low due to sample matrix interference associated with surrogate recoveries.</p> <p>^a Gasoline range hydrocarbons (GRO) analyzed by Ecology Methods NWTPH-Gx or WTPH-G.</p> <p>^b Diesel and heavy oil range hydrocarbons (DRO and HO) analyzed by Ecology Methods NWTPH-Dx or WTPH-D.</p> <p>^c TPH = Total petroleum hydrocarbons (combined concentrations of GRO, DRO and HO). If nondetected, ½ of the method reporting limit (MRL) was used to calculate TPH.</p> <p>^d Benzene analyzed by EPA Method 8021B.</p> <p>^e Total dissolved carcinogenic polycyclic aromatic hydrocarbons (cPAHs) analyzed by EPA Method 8270C.</p> <p>^f Each cPAH compound in a sample was multiplied by that component's toxicity equivalency factor and then the adjusted concentrations were summed to determine the total cPAH concentration. If a cPAH compound was not detected in a sample at a concentration above the MRL, then 1/2 of the MRL for that compound was used.</p> <p>^g Dissolved arsenic analyzed by EPA 200 Series Method.</p> <p>^h Proposed site cleanup level for TPH is 506 µg/L beneath the eastern part of the lower yard and 706 µg/L beneath the western part of the lower yard.</p> <p>ⁱ GRO, DRO, and HO were not detected and the TPH concentration equals the sum of ½ of the MRL of each constituent.</p> <p>^j cPAH compounds were not detected in the sample and the total dissolved cPAH concentration equals the sum of 1/2 of the MRL of each compound multiplied by the compound's toxicity equivalence factor.</p>									



2007-2008 Phase I Remedial
Implementation As-Built Report

TABLE 4
Excavation Soil Sample Analytical Results
 Unocal Edmonds Bulk Fuel Terminal Lower Yard
 Phase I Remedial Implementation As-built Report
 11720 Unoco Road
 Edmonds, Washington

Sample ID	Sample Depth (feet bgs)	Date Sampled	BTEX (mg/kg)				Total cPAHs Adjusted for Toxicity (mg/kg) CUL = 0.14 mg/kg	Gasoline (mg/kg)	Diesel (mg/kg)	Heavy Oil (Lube) (mg/kg)	Total TPH (mg/kg) REL = 2,975
			B	T	E	X					
			REL = 18 mg/kg								
B2-TP1-5	5	02/18/08	0.0305 U	0.0508 U	0.0508 U	0.102 U	0.0179	23.6 JZ	2,170 Q9	393 Q9	2,590 J
B2-TP1-10	10	02/18/08	0.0371 U	0.0618 U	0.0618 U	0.124 U	0.0370	9.96 JZ	211 Q9	60.8	282 J
B2-TP1-15	15	02/18/08	0.0325 U	0.0541 U	0.0541 U	0.108 U	0.00893	12.7 JZ	274 Q9	76.9	364 J
B2-TP2-5	5	02/18/08	0.0371 U	0.0619 U	0.0619 U	0.124 U	0.00853	6.19 U	54.6 Q9	103	161
B2-TP2-10	10	02/18/08	0.0319 U	0.0532 U	0.0532 U	0.106 U	0.00846	25.9 JZ	105 Q9	46.2	177 J
B2-TP2-13	13	02/18/08	0.341 U	0.568 U	0.568 U	3.40	0.519	659 JZ	1,680	1,120	3,460 J
EX-A1-C-16-7	7	11/15/07	0.0303 U	0.0504 U	0.0504 U	0.101 U	NA	5.04 U	11.9 U	29.6 U	23.3 UU
EX-A1-C-16-NSW-3	3	11/15/07	0.0301 U	0.0502 U	0.0502 U	0.100 U	0.00892	5.02 U	93.9 Q4	165 Q4	261
EX-A1-C-17-3	3	11/15/07	0.0608	0.0771	0.0499 U	0.0998 U	0.0154	19.5	70.6 Q4	123 Q4	213
EX-A1-D-16-12	12	11/19/07	0.0299 U	0.0498 U	0.0498 U	0.0996 U	NA	4.98 U	12.1 U	30.2 U	23.6 UU
EX-A1-D-17-12	12	11/15/07	0.0294 U	0.0490 U	0.0490 U	0.0981 U	NA	4.90 U	12.6 U	31.5 U	24.5 UU
EX-A1-D-17-ESW-5	5	11/15/07	0.0316 U	0.0526 U	0.0526 U	0.105 U	NA	5.26 U	11.7 U	29.1 U	23.0 UU
EX-A1-D-17-ESW-10	10	11/15/07	0.0272 U	0.0453 U	0.0453 U	0.0907 U	NA	4.53 U	11.7 U	29.4 U	22.8 UU
EX-A1-E-15-15	15	11/08/07	0.0299 U	0.0498 U	0.0498 U	0.0996 U	NA	4.98 U	12.3 U	30.7 U	24.0 UU
EX-A1-E-16-15	15	11/08/07	0.0279 U [0.0311 U]	0.0465 U [0.0518 U]	0.0465 U [0.0518 U]	0.0930 U [0.104 U]	NA [NA]	4.65 U [5.18 U]	11.6 U [12.6 U]	29.0 U [31.5 U]	22.6 UU [24.6 UU]
EX-A1-E-17-12	12	11/14/07	0.0291 U	0.0485 U	0.0485 U	0.0970 U	NA	4.85 U	12.2 U	30.4 U	23.7 UU
EX-A1-E-17-ESW-4	4	11/15/07	0.0637	0.0514 U	0.0514 U	0.103 U	NA	5.14 U	12.2 U	30.6 U	24.0 UU
EX-A1-F-15-15	15	11/08/07	0.0270 U	0.0451 U	0.0451 U	0.0902 U	NA	4.51 U	12.2 U	30.4 U	23.6 UU
EX-A1-F-16-15	15	11/08/07	0.137	0.0454 U	0.0454 U	0.0907 U	NA	4.54 U	12.0 U	30.1 U	23.3 UU
EX-A1-F-17-3	3	10/29/07	0.0267 U	0.0444 U	0.0444 U	0.0889 U	NA	4.44 U	11.2 U	28.0 U	21.8 UU
EX-A1-F-17-12	12	11/14/07	0.0301 U	0.0501 U	0.0501 U	0.100 U	NA	5.01 U	12.3 U	30.8 U	24.1 UU
EX-A1-F-18-4	4	10/29/07	0.0979 [0.0591]	0.0816 [0.0492]	0.351 [0.222]	1.01 [0.670]	0.0432 [0.0441]	201 JZ [139 JZ]	405 Q11 [1,020 Q11]	158 [339]	764 J [1,500 J]
EX-A1-F-18-5	5	11/05/07	0.0273 U [0.0291 U]	0.0455 U [0.0485 U]	0.0455 U [0.0485 U]	0.0911 U [0.0970 U]	NA [NA]	4.55 U [4.85 U]	11.3 U [11.3 U]	28.2 U [28.3 U]	22.0 UU [22.2 UU]
EX-A1-G-15-15	15	11/08/07	0.0289 U	0.0482 U	0.0482 U	0.0964 U	NA	4.82 U	11.7 U	29.3 U	22.9 UU
EX-A1-G-16-15	15	10/31/07	0.0387	0.0494 U	0.0494 U	0.0989 U	NA	4.94 U	11.7 U	29.3 U	23.0 UU
EX-A1-G-17-15	15	10/29/07	0.0291 U	0.0485 U	0.0485 U	0.0970 U	NA	4.85 U	12.0 U	30.1 U	23.5 UU
EX-A1-H-15-15	15	11/08/07	0.0291 U	0.0486 U	0.0486 U	0.0971 U	NA	4.86 U	12.8 U	31.9 U	24.8 UU
EX-A1-H-16-15	15	10/31/07	0.0303 U	0.0505 U	0.0505 U	0.101 U	NA	5.05 U	11.7 U	29.4 U	23.1 UU
EX-A1-H-17-15	15	10/29/07	0.0298 U [0.0282 U]	0.0497 U [0.0470 U]	0.0497 U [0.0470 U]	0.0993 U [0.0939 U]	NA [NA]	4.97 U [4.70 U]	12.8 U [12.7 U]	31.9 U [31.7 U]	24.8 UU [24.6 UU]
EX-A1-I-16-15	15	10/31/07	0.0285 U	0.0474 U	0.0474 U	0.0948 U	NA	4.74 U	12.5 U	31.1 U	24.2 UU
EX-A1-I-17-15	15	10/29/07	0.0317 U	0.0528 U	0.0528 U	0.106 U	NA	5.28 U	12.7 U	31.8 U	24.9 UU
EX-A1-J-16-15	15	10/31/07	0.0306 U	0.0511 U	0.0511 U	0.102 U	NA	5.11 U	12.7 U	31.7 U	24.8 UU
EX-A1-J-17-15	15	10/29/07	0.0316 U	0.0527 U	0.0527 U	0.105 U	NA	5.27 U	13.6 U	34.0 U	26.4 UU
EX-A1-J-19-8	8	10/23/07	0.0312 U	0.0519 U	0.0519 U	0.104 U	NA	5.19 U	12.6 U	31.5 U	24.6 UU
EX-A1-K-17-15	15	10/30/07	0.0308 U	0.0513 U	0.0513 U	0.103 U	NA	5.13 U	12.7 U	31.8 U	24.8 UU
EX-A1-K-18-12	12	10/23/07	0.0278 U	0.0463 U	0.0463 U	0.0926 U	NA	4.63 U	11.7 U	29.3 U	22.8 UU
EX-A1-K-18-SSW-3	3	10/30/07	0.0282 U	0.0470 U	0.0470 U	0.0941 U	NA	4.70 U	10.5 U	26.1 U	20.7 UU
EX-A1-K-18-SSW-8	8	10/30/07	0.0291 U	0.0486 U	0.0486 U	0.0972 U	NA	4.86 U	11.4 U	28.4 U	22.3 UU
EX-A1-K-19-3	3	10/30/07	0.0322 U	0.0536 U	0.0536 U	0.107 U	NA	5.36 U	11.6 U	29.0 U	23.0 UU
EX-A1-L-17-12	12	11/08/07	0.117	0.0465 U	0.0465 U	0.0930 U	NA	4.65 U	11.7 U	29.4 U	22.9 UU
EX-A2-O-9-10	10	01/28/08	0.369 U [0.344 U]	0.615 U [0.573 U]	0.989 [0.819]	1.72 [1.43]	0.0515 [0.0484]	466 JZ [389 JZ]	149 [371]	78.5 [91.5]	694 J [852 J]

TABLE 4
Excavation Soil Sample Analytical Results
Unocal Edmonds Bulk Fuel Terminal Lower Yard
Phase I Remedial Implementation As-built Report
11720 Unoco Road
Edmonds, Washington

Sample ID	Sample Depth (feet bgs)	Date Sampled	BTEX (mg/kg)				Total cPAHs Adjusted for Toxicity (mg/kg) CUL = 0.14 mg/kg	Gasoline (mg/kg)	Diesel (mg/kg)	Heavy Oil (Lube) (mg/kg)	Total TPH (mg/kg) REL = 2,975
			B	T	E	X					
			REL = 18 mg/kg								
EX-A2-O-10-10	10	01/28/08	0.0299 U	0.169	0.0864	0.215	0.0239	73.9 JZ	30.6	29.3 U	119 J
EX-A2-O-11-10	10	01/28/08	0.0270 U	0.0450 U	0.0450 U	0.0900 U	NA	4.50 U	11.8 U	29.6 U	23.0 UU
EX-A2-O-12-10	10	01/28/08	0.0305 U	0.0508 U	0.0508 U	0.102 U	NA	5.08 U	13.0 U	32.5 U	25.3 UU
EX-A2-O-13-10	10	01/28/08	0.0351 U	0.0585 U	0.0585 U	0.117 U	NA	5.85 U	12.9 U	32.3 U	25.5 UU
EX-A2-N-16-SSW-6	6	02/20/08	0.0382 U	0.0636 U	0.0654	0.845	0.0868	489 JZ	6,770 D	577 U	7,550 J
EX-A2-O-15-SSW-6	6	02/20/08	1.69	0.645 U	1.07	3.10	0.0308	1,500 JZ	5,750 DQ10	579 U	7,540 J
EX-A2-P-9-15	15	01/30/08	0.0289 U	0.0482 U	0.0482 U	0.0965 U	NA	4.82 U	12.0 U	30.1 U	23.5 UU
EX-A2-P-10-11	11	01/30/08	0.0350 U	0.0583 U	0.0583 U	0.117 U	NA	5.83 U	12.7 U	31.8 U	25.2 UU
EX-A2-P-11-11	11	01/30/08	0.0301 U	0.0501 U	0.0501 U	0.100 U	NA	5.01 U	11.3 U	28.2 U	22.3 UU
EX-A2-P-12-10	10	01/30/08	0.0275 U	0.0458 U	0.0458 U	0.0916 U	0.00921	4.58 U	17.2 JY	43.2	62.7 J
EX-A2-P-13-10	10	01/30/08	0.0318 U	0.0531 U	0.0531 U	0.106 U	NA	5.31 U	12.9 U	32.4 U	25.3 UU
EX-A2-P-14-12	12	02/22/08	0.0364 U	0.0607 U	0.0607 U	0.326	0.00974	67.7 JZ	229	32.2	329 J
EX-A2-Q-9-12	12	02/01/08	0.0333 U	0.0555 U	0.0555 U	0.111 U	NA	5.55 U	11.8 U	29.5 U	23.4 UU
EX-A2-Q-10-12	12	02/01/08	0.0364 U	0.0606 U	0.0606 U	0.121 U	NA	6.06 U	11.9 U	29.8 U	23.9 UU
EX-A2-Q-11-12	12	02/01/08	0.0366 U	0.0610 U	0.0610 U	0.122 U	NA	6.10 U	12.2 U	30.5 U	24.4 UU
EX-A2-Q-12-13	13	02/01/08	0.0324 U	0.0539 U	0.0539 U	0.108 U	NA	5.39 U	12.2 U	30.6 U	24.1 UU
EX-A2-Q-13-12	12	02/22/08	0.0404 U	0.0673 U	0.0673 U	0.135 U	NA	6.73 U	12.8 U	32.1 U	25.8 UU
EX-A2-Q-14-6	6	02/20/08	0.169 J	0.0968 J	0.182 J	1.51 J	0.0241	570 JZ	2,250 J	236 JQ7	3,060 J
EX-A2-R-10-12	12	02/15/08	0.0422 U [0.0375 U]	0.0704 U [0.0626 U]	0.0704 U [0.0626 U]	0.141 U [0.125 U]	NA [NA]	7.04 U [6.26 U]	12.8 U [12.1 U]	31.9 U [30.3 U]	25.9 UU [24.3 UU]
EX-A2-R-11-12	12	02/15/08	0.0484 U	0.0806 U	0.0806 U	0.161 U	NA	8.06 U	13.8 U	34.6 U	28.2 UU
EX-A2-R-12-12	12	02/15/08	0.0380 U	0.0634 U	0.0634 U	0.127 U	NA	6.34 U	12.2 U	30.5 U	24.5 UU
EX-A2-R-13-12	12	02/22/08	0.0433 U	0.0721 U	0.0721 U	0.144 U	NA	7.21 U	13.2 U	33.0 U	26.7 UU
EX-A2-R-14-6	6	02/20/08	0.0380 U	0.0633 U	0.0633 U	0.127 U	0.0157	51.3 JZ	224	65.5	341 J
EX-A2-S-12-12	12	02/22/08	0.0406 U	0.0676 U	0.0676 U	0.135 U	NA	6.76 U	12.8 U	32.0 U	25.8 UU
EX-A2-S-12-SSW-6	6	02/15/08	0.0339 U	0.0565 U	0.0565 U	0.113 U	0.00815	224 JZ	900	37.4 Q7	1,160 J
EX-A2-S-13-6	6	02/15/08	0.0356 U	0.0594 U	0.0594 U	0.406	0.00861	194 JZ	683	54.8 Q7	932 J
EX-A3-AA-5-10	10	09/26/07	0.0290 U	0.0484 U	0.0484 U	0.0968 U	NA	4.84 U	12.3 U	30.7 U	23.9 UU
EX-A3-AA-6-10	10	09/21/07	0.0309 U	0.0515 U	0.0515 U	0.103 U	NA	5.15 U	10.9 U	27.1 U	21.6 UU
EX-A3-AA-7-10	10	09/21/07	0.0333 U	0.0556 U	0.0556 U	0.111 U	NA	5.56 U	12.5 U	31.3 U	24.7 UU
EX-A3-AA-7-ESW-4	4	09/20/07	0.0307 U	0.0511 U	0.0511 U	0.102 U	NA	5.11 U	12.7 U	31.8 U	24.8 UU
EX-A3-BB-6-10	10	09/21/07	0.0296 U [0.0299 U]	0.0493 U [0.0498 U]	0.0493 U [0.0498 U]	0.0986 U [0.0996 U]	NA [NA]	4.93 U [4.98 U]	12.7 U [13.0 U]	31.7 U [32.6 U]	24.7 UU [25.3 UU]
EX-A3-BB-7-10	10	09/21/07	0.0703	0.0527 U	0.0527 U	0.105 U	NA	5.27 U	11.9 U	29.7 U	23.4 UU
EX-A3-BB-7-ESW-4	4	09/21/07	0.158	0.152	0.0856	0.282	0.00997	88.0	18.9	32.6 U	123
EX-A3-CC-6-10	10	10/01/07	2.76	0.0582 U	0.0582 U	0.116 U	NA	7.09 J	12.3 U	30.9 U	28.7 J
EX-A3-CC-7-10	10	10/01/07	1.21 [1.73]	0.0671 U [0.0580 U]	0.0671 U [0.0580 U]	0.134 U [0.116 U]	NA [NA]	6.71 U [5.90]	12.1 U [12.1 U]	30.3 U [30.3 U]	24.6 UU [27.1]
EX-A3-CC-7-ESW-4	4	10/02/07	0.110	0.0512 U	0.245	0.221	0.00876	25.8	85.6 Q4	44.7 Q4	156
EX-A3-DD-6-10	10	10/02/07	0.0878	0.0534 U	0.0534 U	0.107 U	NA	5.34 U	11.9 U	29.6 U	23.4 UU
EX-A3-Y-4-8	8	09/21/07	0.0214 U	0.0357 U	0.0357 U	0.0713 U	NA	3.57 U	10.4 U	25.9 U	19.9 UU
EX-A3-Y-4-NSW-4	4	09/20/07	0.0267 U	0.0446 U	0.0446 U	0.0891 U	0.00868	8.24 JZ	169	140	317 J
EX-A3-Y-4-WSW-4	4	09/20/07	0.0114 U	0.0190 U	0.0190 U	0.0380 U	NA	1.90 U	10.4 U	25.9 U	19.1 UU
EX-A3-Y-5-8	8	09/21/07	0.0275 U	0.0458 U	0.0458 U	0.0916 U	NA	4.58 U	10.3 U	25.9 U	20.4 UU
EX-A3-Y-5-NSW-4	4	09/20/07	0.0498 U	0.0830 U	0.0830 U	0.166 U	0.00880	19.4 JZ	111	122	252 J
EX-A3-Y-6-8	8	09/20/07	3.32 U	5.53 U	5.53 U	11.1 U	0.176	3,000	6,340 J	1,270 J	10,600 J
EX-A3-Y-6-10	10	09/25/07	0.387	0.0500 U	0.0500 U	0.100 U	NA	5.25	12.2 U	30.5 U	26.6
EX-A3-Y-6-NSW-4	4	09/20/07	0.0232 U	0.0386 U	0.0386 U	0.134	0.00793	27.7 JZ	37.4	41.0	106 J
EX-A3-Y-7-8	8	09/20/07	0.194	0.315	0.330	0.403	0.0883	182 JZ	2,240 J	386 J	2,810 J
EX-A3-Y-7-10	10	09/25/07	0.0299 U	0.0498 U	0.0498 U	0.0996 U	NA	4.98 U	11.7 U	29.4 U	23.0 UU
EX-A3-Y-7-ESW-4	4	09/20/07	0.546	0.0518 U	0.0518 U	0.104 U	0.00908	9.13 JZ	103	91.9	204 J
EX-A3-Y-7-NSW-4	4	09/20/07	0.0393 [0.0562 U]	0.0532 [0.0937 U]	0.0735 [0.0937 U]	0.191 [0.187 U]	0.00929 [0.00876]	50.7 JZ [34.1 JZ]	62.9 [133]	60.0 [96.0]	174 J [263 J]
EX-A3-Z-4-10	10	09/21/07	0.0294	0.0485 U	0.0485 U	0.0969 U	NA	5.83	11.4 U	28.4 U	25.7
EX-A3-Z-5-10	10	09/21/07	0.0275 U	0.0459 U	0.0459 U	0.0918 U	NA	4.59 U	11.6 U	29.1 U	22.6 UU
EX-A3-Z-6-10	10	09/21/07	0.191	0.0520 U	0.0520 U	0.104 U	0.00944	5.20 U	18.8	32.0 U	37.4
EX-A3-Z-7-10	10	09/21/07	0.0503	0.0440 U	0.0440 U	0.0879 U	NA	4.40 U	11.1 U	27.8 U	21.7 UU
EX-A3-Z-7-ESW-4	4	09/20/07	0.0207 U	0.0345 U	0.0345 U	0.0690 U	NA	3.45 U	10.6 U	26.4 U	20.2 UU

TABLE 4
Excavation Soil Sample Analytical Results
Unocal Edmonds Bulk Fuel Terminal Lower Yard
Phase I Remedial Implementation As-built Report
11720 Unoco Road
Edmonds, Washington

Sample ID	Sample Depth (feet bgs)	Date Sampled	BTEX (mg/kg)				Total cPAHs Adjusted for Toxicity (mg/kg) CUL = 0.14 mg/kg	Gasoline (mg/kg)	Diesel (mg/kg)	Heavy Oil (Lube) (mg/kg)	Total TPH (mg/kg) REL = 2,975
			B	T	E	X					
			REL = 18 mg/kg								
EX-A4-F-6-4	4	09/12/07	0.0296 U [0.0255 U]	0.0494 U [0.0424 U]	0.0494 U [0.0424 U]	0.0988 U [0.0849 U]	0.00967 [0.00854]	4.94 U [4.24 U]	112 Q4 [209 Q4]	66.2 Q4 [109 Q4]	181 [320]
EX-A4-F-7-4	4	09/12/07	0.295	0.0487 U	0.130	0.415	0.00861	85.0 JZ	13.3 Q11	28.5 U	113 J
EX-A4-F-8-4	4	09/12/07	0.126	0.271	0.383	0.555	0.196	149 JZ	1,510 JQ4	710 JQ4	2,370 J
EX-A4-F-8-6	6	10/17/07	0.0740	0.0567 U	0.0567 U	0.129	0.0465	105 JZ	632	246	983 J
EX-A4-F-8-7	7	11/07/07	0.0313 U	0.0522 U	0.0522 U	0.104 U	NA	5.22 U	12.8 U	32.0 U	25.0 UU
EX-A4-F-8-NSW-3.5	3.5	11/13/07	0.0256 U	0.0427 U	0.0427 U	0.0853 U	NA	4.27 U	10.4 U	26.0 U	20.3 UU
EX-A4-F-8-NSW-4	4	11/07/07	0.0288 U	0.0480 U	0.0480 U	0.0960 U	0.0481	30.9 JZ	793 Q4	429	1,250 J
EX-A4-F-9-9	9	10/17/07	0.0646	0.0509 U	0.0619	0.102 U	NA	20.1	11.9 U	29.7 U	40.9
EX-A4-F-9-ESW-4	4	10/17/07	0.0349 U	0.0581 U	0.0581 U	0.116 U	0.0100	5.81 U	17.3 Q12	33.3 U	36.9
EX-A4-F-9-NSW-3.5	3.5	11/07/07	0.0318 U	0.0530 U	0.0530 U	0.106 U	0.0402	5.30 U	330 Q4	356	689
EX-A4-F-9-NSW-4	4	10/17/07	0.248	0.248	0.208	0.105 U	0.0710	219 JZ	731	222	1,170 J
EX-A4-G-6-9	9	10/01/07	0.0307 U	0.0512 U	0.0512 U	0.102 U	NA	5.12 U	12.7 U	31.8 U	24.8 UU
EX-A4-G-7-9	9	09/27/07	0.0295 U	0.0492 U	0.0492 U	0.0983 U	NA	4.92 U	12.7 U	31.7 U	24.7 UU
EX-A4-G-8-9	9	09/27/07	0.0311 U	0.0519 U	0.0519 U	0.104 U	NA	5.19 U	11.7 U	29.2 U	23.0 UU
EX-A4-G-9-9	9	10/17/07	0.0295 U	0.0492 U	0.0492 U	0.0985 U	NA	4.92 U	12.5 U	31.1 U	24.3 UU
EX-A4-G-9-ESW-4	4	10/17/07	0.0290 U [0.0283 U]	0.0483 U [0.0472 U]	0.0483 U [0.0472 U]	0.0965 U [0.0945 U]	0.00853 [0.00868]	9.59 JZ [4.72 U]	41.4 [33.5]	36.0 [32.7]	87.0 J [68.6]
EX-A4-H-6-9	9	09/27/07	0.0269 U [0.0295 U]	0.0448 U [0.0491 U]	0.0448 U [0.0491 U]	0.0897 U [0.0982 U]	NA [NA]	4.48 U [4.91 U]	12.6 U [12.4 U]	31.5 U [31.1 U]	24.3 UU [24.2 UU]
EX-A4-H-7-9	9	09/27/07	0.0318 U	0.0530 U	0.0530 U	0.106 U	NA	5.30 U	12.9 U	32.3 U	25.3 UU
EX-A4-H-8-4	4	09/12/07	0.0286 U	0.0476 U	0.0476 U	0.0952 U	0.0858	19.6 JZ	1,250 JQ4	788 JQ4	2,060 J
EX-A4-H-8-9	9	09/27/07	0.0885	0.0499 U	0.0499 U	0.0997 U	NA	4.99 U	12.3 U	30.8 U	24.0 UU
EX-A4-H-9-9	9	10/17/07	0.323	0.0736 U	0.0736 U	0.147 U	NA	7.36 U	16.8 U	42.0 U	33.1 UU
EX-A4-H-9-ESW-4	4	10/17/07	0.0273 U	0.0455 U	0.0455 U	0.0911 U	0.00861	4.55 U	203	50.3	256
EX-A4-I-6-9	9	09/21/07	0.0565 U	0.0942 U	0.0942 U	0.188 U	NA	9.42 U	19.9 U	49.7 U	39.5 UU
EX-A4-I-7-9	9	10/16/07	0.0372 U	0.0620 U	0.0620 U	0.124 U	NA	6.20 U	12.1 U	30.2 U	24.3 UU
EX-A4-I-8-9	9	10/16/07	0.0396 U	0.0660 U	0.0660 U	0.132 U	NA	6.60 U	12.1 U	30.2 U	24.5 UU
EX-A4-J-6-9	9	09/21/07	0.0288 U	0.0479 U	0.0479 U	0.0959 U	NA	4.79 U	12.1 U	30.4 U	23.6 UU
EX-A4-J-6-SSW-9	9	09/21/07	0.0304 U	0.0507 U	0.0507 U	0.101 U	0.0383	22.1	111 Q4	105 Q4	238
EX-A4-J-7-9	9	09/21/07	0.0299 U	0.0498 U	0.0498 U	0.0996 U	NA	4.98 U	12.2 U	30.4 U	23.8 UU
EX-A4-J-7-SSW-4	4	09/21/07	0.0342 U	0.0569 U	0.0569 U	0.114 U	0.0388	5.69 U	119 Q4	119 Q4	241
EX-A4-J-8-9	9	10/16/07	0.0340 U	0.0566 U	0.0566 U	0.113 U	NA	5.66 U	11.9 U	29.8 U	23.7 UU
EX-A4-K-8-9	9	10/16/07	0.0367 U	0.0612 U	0.0612 U	0.122 U	NA	6.12 U	12.3 U	30.8 U	24.6 UU
EX-B2-E-33(2)-6	6	02/27/08	0.0345 U	0.0575 U	0.0575 U	0.115 U	0.00872	25.1 JZ	203 Q9	126	354 J
EX-B2-E-33-6	6	02/25/08	0.0326 U	0.0543 U	0.0543 U	0.109 U	0.00883	8.75 JZ	129 Q10	86.6 Q10	224 J
EX-B2-E-34-6	6	02/25/08	0.0331 U	0.0552 U	0.0552 U	0.110 U	0.00923	32.2 JZ	101 Q9	54.2	187 J
EX-B2-E-35(2)-6	6	02/27/08	0.0349 U	0.0582 U	0.0582 U	0.116 U	0.0702	16.5 JZ	1,950 J	1,490 J	3,460 J
EX-B2-E-35(3)-6	6	03/05/08	0.0370 U	0.0617 U	0.0617 U	0.163	0.0993	79.7 JZ	992 Q4	518 Q4	1,590 J
EX-B2-E-35-6	6	02/22/08	0.0336 U	0.0560 U	0.0560 U	0.176	0.117	66.7 JZ	1,270 Q9	687	2,020 J
EX-B2-E-36-6	6	02/27/08	0.0420 U	0.0700 U	0.0700 U	0.140 U	0.0243	20.0 JZ	402 Q9	155	577 J
EX-B2-E-40-4	4	01/23/08	0.0313 U	0.0522 U	0.0522 U	0.104 U	0.00922	5.22 U	48.9 J	48.5 Q4	100 J
EX-B2-E-41(2)-5	5	02/04/08	0.0289 U	0.0482 U	0.0482 U	0.104	0.0879	7.34 JZ	647 Q4	363 Q4	1,020 J
EX-B2-E-41-4	4	01/23/08	0.0262 U [0.0264 U]	0.0436 U [0.0440 U]	0.0436 U [0.0440 U]	0.0872 U [0.0880 U]	0.0528 [0.120]	13.5 JZ [13.3 JZ]	196 Q4 [208 Q4]	152 Q4 [182 Q4]	362 J [403 J]
EX-B2-F-32-12	12	03/03/08	0.108 U	0.180 U	0.180 U	0.360 U	NA	18.0 U	20.6 U	51.4 U	45.0 UU
EX-B2-F-33-12	12	02/28/08	0.0656 U [0.0670 U]	0.109 U [0.112 U]	0.109 U [0.112 U]	0.219 U [0.223 U]	NA [NA]	10.9 U [11.2 U]	16.0 U [15.6 U]	40.1 U [39.1 U]	33.5 UU [33.0 UU]
EX-B2-F-34-11	11	02/28/08	0.0603 U	0.101 U	0.101 U	0.201 U	NA	10.1 U	15.7 U	39.2 U	32.5 UU
EX-B2-F-35-12	12	02/25/08	0.105 U	0.175 U	0.175 U	0.349 U	NA	17.5 U	16.6 U	41.4 U	37.8 UU
EX-B2-F-36-13	13	02/22/08	0.0790 U	0.132 U	0.132 U	0.263 U	0.0205	13.2 U	331 Q9	105	443
EX-B2-F-36-NSW-6	6	02/22/08	0.0409 U	0.0682 U	0.0682 U	0.136 U	0.0305	69.9 JZ	215 Q9	70.9	356 J
EX-B2-F-37-13	13	02/22/08	0.0705 U	0.118 U	0.118 U	0.235 U	NA	11.8 U	16.9 U	42.2 U	35.5 UU
EX-B2-F-37-NSW-6	6	02/22/08	0.0378 U	0.0631 U	0.0631 U	0.126 U	0.00929	8.43	25.3 Q4	30.7 UQ4	64.4
EX-B2-F-38(2)-14	14	02/06/08	0.0570 U	0.0949 U	0.0949 U	0.190 U	NA	9.49 U	15.3 U	38.2 U	31.5 UU
EX-B2-F-38-8	8	01/31/08	0.0357 U	0.0595 U	0.0595 U	0.119 U	0.111	18.9 JZ	1,450	458	1,930 J
EX-B2-F-38-NSW(2)-5	5	02/06/08	0.0350 J	0.123 J	0.397 J	0.637 J	0.0317	214 JZ	329	137	680 J
EX-B2-F-38-NSW(2)-6	6	03/05/08	0.0307 U	0.0512 U	0.0512 U	0.102 U	0.0339	44.9 JZ	374 Q4	187 Q4	606 J
EX-B2-F-38-NSW-4	4	01/31/08	0.0295 U [0.0212 U]	0.0491 U [0.0354 U]	0.0491 U [0.0354 U]	0.0982 U [0.0708 U]	0.00831 [0.0287]	5.97 JZ [13.4 JZ]	25.0 [33.6 J]	28.0 U [28.0 U]	45.0 J [61.0 J]

TABLE 4
Excavation Soil Sample Analytical Results
Unocal Edmonds Bulk Fuel Terminal Lower Yard
Phase I Remedial Implementation As-built Report
11720 Unoco Road
Edmonds, Washington

Sample ID	Sample Depth (feet bgs)	Date Sampled	BTEX (mg/kg)				Total cPAHs Adjusted for Toxicity (mg/kg) CUL = 0.14 mg/kg	Gasoline (mg/kg)	Diesel (mg/kg)	Heavy Oil (Lube) (mg/kg)	Total TPH (mg/kg) REL = 2,975
			B	T	E	X					
			REL = 18 mg/kg								
EX-B2-F-38-WSW-5	5	01/31/08	0.0291 U	0.0486 U	0.0486 U	0.0971 U	0.00909	19.2 JZ	105	48.8	173 J
EX-B2-F-39(2)-12	12	02/05/08	0.0580 U	0.0966 U	0.0966 U	0.193 U	NA	9.66 U	15.2 U	38.0 U	31.4 UU
EX-B2-F-39-8	8	01/28/08	0.0290 U [0.0287 U]	0.0483 U [0.0478 U]	0.0483 U [0.0478 U]	0.0966 U [0.0955 U]	0.0894 [0.00886]	5.35 JZ [5.58 JZ]	1,010 J [51.5 J]	250 J [28.8 UJ]	1,270 J [71.5 J]
EX-B2-F-39-NSW-4	4	01/28/08	0.0308 U	0.0514 U	0.0514 U	0.103 U	0.00853	5.14 U	39.6	28.2 U	56.3
EX-B2-F-40-8	8	01/25/08	0.170	0.216	0.210	0.696	0.00914	6.90	67.8 Q11	42.5	117
EX-B2-F-41-8	8	01/23/08	0.0288 U	0.0480 U	0.0480 U	0.0960 U	0.00847	19.0 JZ	111 Q4	64.3 Q4	194 J
EX-B2-F-41-ESW(2)-5	5	02/04/08	3.30	0.840	2.95	17.2	0.0753	127	513 Q4	478 Q4	1,120
EX-B2-F-41-ESW-4	4	01/23/08	0.0747	0.0420 U	0.319	0.0841 U	0.359	4.20 U	14.5 Q4	29.5 Q4	46.1
EX-B2-G-32-6	6	02/26/08	0.139 J	0.0781 J	1.02 J	2.09 J	0.00959	1,090	1,230 J	161 U	2,400 J
EX-B2-G-33(2)-6	6	02/28/08	0.0340 U	0.0567 U	0.0567 U	0.113 U	0.00891	13.1 JZ	32.7 Q9	28.9 U	60.3 J
EX-B2-G-33-6	6	02/25/08	0.371 U	0.618 U	0.961	2.88	0.139	1,510 JZ	4,860 J	1,690 J	8,060 J
EX-B2-G-34-10	10	02/25/08	0.0308 U	0.0513 U	0.0513 U	0.103 U	NA	5.13 U	11.0 U	27.6 U	21.9 UU
EX-B2-G-34-SSW-6	6	02/25/08	0.0429 U	0.0716 U	0.0716 U	0.143 U	0.0323	31.1 JZ	28.9	31.8 U	75.9 J
EX-B2-G-35-10	10	02/22/08	0.119 U	0.198 U	0.198 U	0.397 U	NA	19.8 U	22.4 U	56.1 U	49.2 UU
EX-B2-G-35-SSW-6	6	02/22/08	0.0361 U [0.0404 U]	0.0601 U [0.0674 U]	0.0601 U [0.245 J]	0.120 U [0.403 J]	0.0167 [0.0474]	6.91 JZ [102 JZ]	19.3 Q9 [42.6 Q9]	30.6 U [35.8]	41.5 J [180 J]
EX-B2-G-36-12	12	02/22/08	0.0423 U	0.0705 U	0.0705 U	0.141 U	0.0240	7.05 U	38.1 Q4	32.5 U	57.9
EX-B2-G-37-13	13	02/22/08	0.0414 U	0.0690 U	0.0690 U	0.138 U	NA	6.90 U	12.8 U	32.0 U	25.9 UU
EX-B2-G-38(2)-13	13	02/06/08	0.0332 U	0.0554 U	0.0554 U	0.111 U	NA	5.54 U	11.8 U	29.6 U	23.5 UU
EX-B2-G-38-8	8	01/31/08	0.0279 U	0.0465 U	0.0577	0.243	0.0702	87.0 JZ	1,020	335	1,440 J
EX-B2-G-38-WSW-5	5	01/31/08	0.0305 U	0.0508 U	0.0545	0.185	0.0516	100 JZ	651	317	1,070 J
EX-B2-G-39(2)-11	11	02/05/08	0.0662 U	0.110 U	0.110 U	0.291	NA	13.5	16.3 U	40.7 U	42.0
EX-B2-G-39-8	8	01/28/08	0.323 U	1.37	1.27	2.35	0.197	568 Q10a	3,450	1,140 Q7	5,160
EX-B2-G-39-SSW-4	4	01/28/08	0.0271 U	0.0452 U	0.0452 U	0.0904 U	0.00861	4.52 U	24.5	30.6	57.4
EX-B2-G-40-8	8	01/25/08	0.0317 U	0.0529 U	0.0529 U	0.106 U	0.00883	5.29 U	59.9 Q11	43.0	106
EX-B2-G-40-SSW-4	4	01/25/08	0.0287 U	0.0479 U	0.0479 U	0.0958 U	0.00906	4.79 U	22.3 Q11	32.6	57.3
EX-B2-G-41-8	8	01/24/08	0.0354 U	0.0939	0.0590 U	0.317	0.00891	61.1 JZ	125 J	110 Q4	296 J
EX-B2-G-41-ESW-4	4	01/24/08	0.0356 U	0.0593 U	0.0593 U	0.119 U	0.0415	5.93 U	438 Q4	361 Q4	802
EX-B2-G-41-SSW-4	4	01/24/08	0.0341 U	0.0568 U	0.0568 U	0.114 U	0.00853	5.68 U	20.1 Q4	57.1 Q4	80.0
EX-B2-H-35-6	6	02/27/08	0.0833 U	0.229	0.139 U	0.278 U	0.0123	18.5	41.4 Q4	40.7 UQ4	101
EX-B2-H-36-6	6	02/22/08	0.0426 U	0.0709 U	0.0790	0.363	0.0225	70.4 JZ	453 Q4	248 Q4	771 J
EX-B2-H-37(2)-6	6	03/05/08	0.0349 U	0.0582 U	0.0582 U	0.159	0.00868	75.0 JZ	312 Q4	513 Q4	900 J
EX-B2-H-37-5	5	02/22/08	0.0398 U	0.0663 U	0.0663 U	0.248	0.167	133 JZ	2,690 J	1,550 J	4,370 J
EX-B2-H-38(2)-10	10	02/06/08	0.0293 U	0.0488 U	0.0488 U	0.0976 U	NA	4.88 U	11.2 U	28.1 U	22.1 UU
EX-B2-H-38-5	5	01/31/08	0.0315 U	0.252 J	0.231 J	0.791 J	0.145	316 JZ	2,940	849	4,110 J
EX-B2-H-38-WSW(2)-5	5	02/06/08	0.0329 U	0.0549 U	0.0549 U	0.110 U	0.0160	6.75 JZ	128 Q4	96.1 Q4	231 J
EX-B2-H-38-WSW-5	5	01/31/08	0.292 URL1	0.487 URL1	0.796	1.25	0.186	406 JZ	2,220	667	3,290 J
EX-B3-E-32-6	6	02/26/08	0.0474 U	0.0790 U	0.0790 U	0.158 U	NA	7.90 U	13.2 U	33.1 U	27.1 UU
EX-B3-F-31-12	12	03/10/08	0.0604 U	0.101 U	0.101 U	0.201 U	NA	10.1 U	15.1 U	37.8 U	31.5 UU
EX-B3-F-31-NSW-6	6	03/10/08	0.0306 U	0.0510 U	0.0510 U	0.102 U	0.00891	5.10 U	13.8 Q4	29.7 U	31.2
EX-B3-G-29-5	5	03/11/08	0.0356 U	0.0594 U	0.0594 U	0.119 U	NA	5.94 U	11.5 U	28.8 U	23.1 UU
EX-B3-G-29-NSW-4	4	03/11/08	0.0313 U	0.0522 U	0.0522 U	0.104 U	0.0300	5.22 U	27.1 JY	161	191 J
EX-B3-G-29-SSW-5	5	03/11/08	0.0377 U [0.0345 U]	0.0629 U [0.0575 U]	0.0629 U [0.0575 U]	0.126 U [0.115 U]	NA [NA]	6.29 U [5.75 U]	12.4 U [11.3 U]	30.9 U [28.4 U]	24.8 UU [22.7 UU]
EX-B3-G-30-12	12	03/11/08	0.0352 U	0.0586 U	0.0586 U	0.117 U	NA	5.86 U	11.9 U	29.9 U	23.8 UU
EX-B3-G-30-NSW-6	6	03/11/08	0.108	0.0711 U	0.0711 U	0.142 U	0.0184	12.8 JZ	169 Q4	120 Q4	302 J
EX-B3-G-30-SSW-6	6	03/10/08	0.0322 U	0.0536 U	0.0536 U	0.107 U	NA	5.36 U	11.5 U	28.7 U	22.8 UU
EX-B3-G-31-12	12	03/10/08	0.0368 U	0.0613 U	0.0613 U	0.123 U	NA	6.13 U	12.5 U	31.3 U	25.0 UU
EX-B3-G-31-SSW-6	6	03/10/08	0.0427 U	0.0711 U	0.0711 U	0.224	NA	27.4	12.3 U	30.8 U	49.0
EX-B4-B-23-6	6	02/25/08	0.0297 U [0.0321 U]	0.263 J [0.0679 J]	0.0494 U [0.0535 U]	0.0988 U [0.107 U]	0.0145 [NA]	4.94 U [5.35 U]	15.5 JY [11.2 U]	27.8 U [28.0 U]	31.9 J [22.3 UU]
EX-B4-B-24-6	6	02/25/08	0.0366 U	0.0610 U	0.0610 U	0.122 U	NA	6.10 U	12.1 U	30.3 U	24.3 UU
EX-B5-B-20(2)-4	4	02/28/08	0.0354 U	0.0590 U	0.0590 U	0.118 U	NA	5.90 U	12.1 U	30.3 U	24.2 UU
EX-B5-B-20-4	4	02/22/08	0.0363 U	0.0605 U	0.0605 U	0.121 U	0.111	6.05 U	592 Q4	473 Q4	1,070
EX-B6-C-15-3	3	11/19/07	0.0335 U	0.0559 U	0.0559 U	0.112 U	NA	5.59 U	12.6 U	31.5 U	24.8 UU
EX-B6-D-13-3	3	11/19/07	0.0269 U	0.0448 U	0.0448 U	0.0895 U	0.00846	12.1	61.6	27.7 U	87.6
EX-B6-D-14-10	10	11/19/07	0.0321 U	0.0535 U	0.0535 U	0.107 U	NA	6.31	12.2 U	30.5 U	27.7

TABLE 4
Excavation Soil Sample Analytical Results
 Unocal Edmonds Bulk Fuel Terminal Lower Yard
 Phase I Remedial Implementation As-built Report
 11720 Unoco Road
 Edmonds, Washington

Sample ID	Sample Depth (feet bgs)	Date Sampled	BTEX (mg/kg)				Total cPAHs Adjusted for Toxicity (mg/kg) CUL = 0.14 mg/kg	Gasoline (mg/kg)	Diesel (mg/kg)	Heavy Oil (Lube) (mg/kg)	Total TPH (mg/kg) REL = 2,975
			B	T	E	X					
			REL = 18 mg/kg								
EX-B6-D-14-NSW-3	3	11/19/07	0.0369 U	0.0616 U	0.0616 U	0.123 U	NA	6.16 U	15.0 U	37.4 U	29.3 UU
EX-B6-D-15-12	12	11/19/07	0.0332 U [0.0323 U]	0.0554 U [0.0538 U]	0.0554 U [0.0538 U]	0.111 U [0.108 U]	NA [NA]	5.54 U [5.79]	13.2 U [12.6 U]	33.0 U [31.6 U]	25.9 UU [27.9]
EX-B6-E-13-4	4	11/19/07	0.0261 U [0.0270 U]	0.0435 U [0.0449 U]	0.0435 U [0.0449 U]	0.0870 U [0.0899 U]	0.00853 [0.00853]	4.35 U [4.49 U]	146 J [33.6 J]	113 [28.4 U]	261 J [50.0 J]
EX-B6-E-14-10	10	11/19/07	0.0312 U	0.0520 U	0.0520 U	0.104 U	NA	5.20 U	12.1 U	30.2 U	23.8 UU
EX-B6-F-14-10	10	11/19/07	0.0302 U	0.0504 U	0.0504 U	0.101 U	NA	5.04 U	12.6 U	31.5 U	24.6 UU
EX-B6-F-14-WSW-3	3	11/19/07	0.0275 U	0.0459 U	0.0459 U	0.0918 U	0.00846	4.59 U	42.4 Q11	28.0 U	58.7
EX-B8-F-4-4	4	10/01/07	0.0278 U	0.0464 U	0.0464 U	0.0928 U	0.0222	53.6 JZ	1,070 Q4	496 Q4	1,620 J
EX-B8-F-4-9	9	10/22/07	0.224	0.0784	0.0625 U	0.125 U	0.0468	6.25 U	801 Q4	347 Q4	1,150
EX-B8-F-4-NSW-4	4	10/22/07	0.0326 U	0.0543 U	0.0543 U	0.109 U	0.0422	80.7	834 Q4	332 Q4	1,250
EX-B8-F-4-NSW-6	6	10/09/07	0.0318 U [0.0324 U]	0.0531 U [0.0540 U]	0.0531 U [0.0540 U]	0.106 U [0.108 U]	0.0424 [0.0854]	23.5 JZ [52.2 JZ]	1,310 Q4 [2,440 J]	496 Q4 [1,030 J]	1,830 J [3,520 J]
EX-B8-F-4NSW-6	6	10/15/07	0.0428 U	0.0713 U	0.0713 U	0.143 U	0.112	53.2 JZ	3,850 Q4	1,760 Q4	5,660 J
EX-B8-F-4-WSW-4	4	10/01/07	0.0400 U	0.0666 U	0.0666 U	0.133 U	NA	6.66 U	10.9 U	27.3 U	22.4 UU
EX-B8-F-5-4	4	10/01/07	0.0374 U	0.0623 U	0.0623 U	0.125 U	0.0885	94.8 JZ	462 J	424 J	981 J
EX-B8-F-5-NSW-6	6	10/09/07	0.0292 U	0.0487 U	0.0487 U	0.0975 U	0.00909	16.3 JZ	422 Q4	187 Q4	625 J
EX-B8-G-4-9	9	10/01/07	0.0308 U	0.0514 U	0.0514 U	0.103 U	0.00921	5.14 U	18.2	30.5 U	36.0
EX-B8-G-4-WSW-4	4	10/01/07	0.0271 U	0.0452 U	0.0452 U	0.0904 U	0.0808	5.76 JZ	133 J	245 J	384 J
EX-B8-G-5-9	9	10/01/07	0.0319 U	0.0532 U	0.0532 U	0.106 U	NA	5.32 U	13.3 U	33.2 U	25.9 UU
EX-B8-H-4-9	9	10/01/07	0.0324 U	0.0540 U	0.0540 U	0.108 U	NA	5.40 U	11.9 U	29.8 U	23.6 UU
EX-B8-H-4-WSW-4	4	10/01/07	0.0279 U	0.0465 U	0.0465 U	0.0931 U	0.0768	86.7 JZ	2,080 Q4	1,100 Q4	3,270 J
EX-B8-H-5-9	9	10/01/07	0.0353 U	0.0588 U	0.0588 U	0.118 U	NA	5.88 U	12.2 U	30.4 U	24.2 UU
EX-B8-I-4-9	9	10/01/07	0.0817	0.0498 U	0.0498 U	0.0996 U	NA	4.98 U	12.2 U	30.4 U	23.8 UU
EX-B8-I-4-WSW-4	4	10/01/07	0.0323 U [0.0334 U]	0.0539 U [0.0557 U]	0.0539 U [0.0557 U]	0.108 U [0.111 U]	0.0991 [0.0524]	25.4 JZ [34.7 JZ]	3,130 Q4 [1,990 Q4]	1,480 Q4 [1,010 Q4]	4,640 J [3,030 J]
EX-B8-I-5-9	9	10/01/07	0.0292 U	0.0486 U	0.0486 U	0.0972 U	NA	4.86 U	12.1 U	30.2 U	23.6 UU
EX-B8-J-4-4	4	10/01/07	0.0217 U	0.0362 U	0.0362 U	0.0723 U	0.165	80.5 JZ	1,530 Q4	798 Q4	2,410 J
EX-B8-J-4-5	5	10/23/07	0.0251 U	0.0419 U	0.0419 U	0.0838 U	0.0170	4.19 U	146 Q4	167 Q4	315
EX-B8-J-4-SSW-2.5	2.5	10/23/07	0.0331 U	0.0552 U	0.0552 U	0.110 U	NA	5.52 U	10.9 U	27.3 U	21.9 UU
EX-B8-J-5-4	4	10/01/07	0.0272 U	0.0453 U	0.0453 U	0.0907 U	0.00831	4.53 U	35.9 JY	43.8	82.0 J
EX-B8-J-5-9	9	10/01/07	0.0366 U	0.0610 U	0.0610 U	0.122 U	NA	6.10 U	11.3 U	28.4 U	22.9 UU
EX-B9-M-4-11	11	02/20/08	0.0315 U	0.0524 U	0.0524 U	0.105 U	NA	5.24 U	11.6 U	29.1 U	23.0 UU
EX-B9-M-4-NSW-6	6	02/19/08	0.329 U	0.548 U	0.548 U	1.71	0.00907	755 JZ	439 Q4	211 Q4	1,410 J
EX-B9-M-4-WSW-6	6	02/19/08	0.336 U	0.561 U	0.561 U	1.84	0.0173	816 JZ	537 JX	141 U	1,420 J
EX-B9-M-5-11	11	02/19/08	0.0411 U	0.0685 U	0.0685 U	0.137 U	NA	6.85 U	13.0 U	32.5 U	26.2 UU
EX-B9-M-5-NSW-6	6	02/19/08	0.0285 U	0.0475 U	0.0475 U	0.0950 U	0.00823	98.5 JZ	40.9 Q4	27.1 UQ4	167 J
EX-B9-M-6-11	11	02/19/08	0.0364 U [0.0453 U]	0.0606 U [0.0755 U]	0.0606 U [0.0755 U]	0.121 U [0.151 U]	NA [NA]	6.06 U [7.55 U]	12.5 U [13.4 U]	31.4 U [33.4 U]	25.0 UU [27.2 UU]
EX-B9-M-6-NSW-6	6	02/19/08	0.0383 U	0.0638 U	0.291	0.426	NA	16.2	13.0 U	32.6 U	39.0
EX-B9-N-4-11	11	02/20/08	0.0349 U	0.0582 U	0.0582 U	0.116 U	NA	5.82 U	12.1 U	30.3 U	24.1 UU
EX-B9-N-4-WSW-6	6	02/20/08	0.0338 U	0.250 J	0.172 J	0.871 J	0.00891	276 JZ	139 Q4	128 Q4	543 J
EX-B9-N-5-12	12	02/13/08	0.0343 U	0.0572 U	0.0572 U	0.114 U	NA	5.72 U	11.8 U	29.6 U	23.6 UU
EX-B9-O-4-12	12	02/20/08	0.0373 U [0.0373 U]	0.0622 U [0.0621 U]	0.0622 U [0.0621 U]	0.128 [0.209]	NA [NA]	20.2 [15.9]	12.3 U [12.5 U]	30.7 U [31.2 U]	41.7 [37.8]
EX-B9-O-4-WSW-6	6	02/20/08	0.0322 U	0.0536 U	0.0536 U	0.107 U	0.00800	50.7 JZ	24.4	26.5 U	88.4 J
EX-B9-O-5-12	12	02/13/08	0.0365 U [0.0354 U]	0.0609 U [0.0591 U]	0.0609 U [0.0591 U]	0.122 U [0.118 U]	NA [NA]	6.09 U [5.91 U]	11.8 U [11.9 U]	29.6 U [29.7 U]	23.7 UU [23.8 UU]
EX-B9-P-4-12	12	02/20/08	0.0396 U	0.0660 U	0.0660 U	0.132 U	NA	8.18	12.6 U	31.5 U	30.2
EX-B9-P-4-SSW(2)-6	6	02/25/08	0.332 U	0.553 U	0.553 U	3.82	0.0194	967 JZ	470 JX	138 U	1,510 J
EX-B9-P-4-SSW-6	6	02/20/08	0.295 U	0.491 U	0.595	3.53	0.0316	898 JZ	1,430 Q4	248 Q4	2,580 J
EX-B9-P-4-WSW-6	6	02/20/08	0.0333 U	0.0556 U	0.0556 U	0.111 U	NA	5.56 U	11.8 U	29.5 U	23.4 UU
EX-B9-P-5-12	12	02/13/08	0.0315 U	0.0525 U	0.0525 U	0.105 U	NA	5.25 U	11.6 U	29.0 U	22.9 UU
EX-B9-Q-5-6	6	02/13/08	0.0175 U	0.0291 U	0.0291 U	0.0582 U	0.0145	2.91 U	56.5 Q4	35.4 Q4	93.4
EX-B10-N-6-10	10	02/08/08	0.0361 U	0.0601 U	0.0601 U	0.120 U	NA	6.01 U	12.4 U	31.1 U	24.8 UU
EX-B10-O-6-10	10	02/08/08	0.0352 U	0.0586 U	0.0586 U	0.117 U	NA	5.86 U	12.3 U	30.8 U	24.5 UU
EX-B10-O-7-12	12	01/16/08	0.0302 U [0.0330 U]	0.0503 U [0.0550 U]	0.0503 U [0.0550 U]	0.101 U [0.110 U]	NA [NA]	5.03 U [5.50 U]	12.2 U [13.3 U]	30.5 U [33.3 U]	23.9 UU [26.1 UU]
EX-B10-O-8-12	12	01/16/08	0.0316 U	0.0527 U	0.0527 U	0.105 U	NA	5.27 U	12.7 U	31.8 U	24.9 UU
EX-B10-P-6-10	10	02/08/08	0.0400 U	0.0666 U	0.0666 U	0.176	NA	8.23	12.6 U	31.6 U	30.3
EX-B10-P-7-15	15	01/30/08	0.0328 U	0.0546 U	0.0546 U	0.109 U	NA	9.68	13.2 U	32.9 U	32.7
EX-B10-P-8-15	15	01/30/08	0.0322 U	0.0536 U	0.0536 U	0.107 U	NA	5.36 U	12.2 U	30.5 U	24.0 UU

TABLE 4
Excavation Soil Sample Analytical Results
Unocal Edmonds Bulk Fuel Terminal Lower Yard
Phase I Remedial Implementation As-built Report
11720 Unoco Road
Edmonds, Washington

Sample ID	Sample Depth (feet bgs)	Date Sampled	BTEX (mg/kg)				Total cPAHs Adjusted for Toxicity (mg/kg) CUL = 0.14 mg/kg	Gasoline (mg/kg)	Diesel (mg/kg)	Heavy Oil (Lube) (mg/kg)	Total TPH (mg/kg) REL = 2,975
			B	T	E	X					
			REL = 18 mg/kg								
EX-B10-Q-6-11	11	02/08/08	0.0343 U	0.0572 U	0.0572 U	0.114 U	NA	5.73	12.8 U	32.1 U	28.2
EX-B10-Q-7-15	15	01/30/08	0.0309 U	0.0516 U	0.0516 U	0.103 U	NA	5.16 U	12.5 U	31.3 U	24.5 UU
EX-B11-Q-8-14	14	01/30/08	0.0306 U [0.0317]	0.0510 U [0.0496 U]	0.0510 U [0.0496 U]	0.102 U [0.0991 U]	0.00891 [NA]	5.80 [4.96 U]	20.1 JY [11.8 U]	29.7 U [29.5 U]	40.8 J [23.1 UU]
EX-B11-R-6-5	5	02/08/08	0.0346 U [0.0340 U]	0.0577 U [0.0566 U]	0.0577 U [0.0566 U]	0.115 U [0.113 U]	0.0224 [0.0258]	56.8 JZ [168 JZ]	1,510 [1,310]	296 [265]	1,860 J [1,740 J]
EX-B11-R-7-12	12	01/22/08	0.0331	0.0688	0.0509 U	0.145	NA	5.09 U	12.0 U	30.0 U	23.5 UU
EX-B11-R-7-WSW-5	5	01/18/08	0.0297 U	0.0495 U	0.0495 U	0.0989 U	0.107	80.4 JZ	7,130	1,360 Q7	8,570 J
EX-B11-R-8-12	12	01/30/08	0.0303	0.0993	0.109	0.565	NA	13.9	11.8 U	29.6 U	34.6
EX-B11-R-9-12	12	02/12/08	0.0612	0.0555 U	0.0555 U	0.111 U	NA	5.55 U	11.7 U	29.3 U	23.3 UU
EX-B11-S-7-12	12	01/22/08	0.0402	0.122	0.0601	0.333	NA	6.08	12.1 U	30.2 U	27.2
EX-B11-S-7-WSW-5	5	01/18/08	0.0290 U	0.0483 U	0.0483 U	0.0966 U	NA	4.83 U	10.9 U	27.2 U	21.5 UU
EX-B11-S-8-12	12	01/30/08	0.0287 U	0.0478 U	0.0478 U	0.0955 U	NA	8.58	12.1 U	30.2 U	29.7
EX-B11-S-9-12	12	02/12/08	0.0413	0.0628 U	0.150	0.457	0.00929	38.7 JZ	67.6	31.1 U	122 J
EX-B11-S-10-2	2	02/15/08	0.0408 U	0.0680 U	0.0680 U	0.136 U	NA	6.80 U	12.7 U	31.8 U	25.7 UU
EX-B11-S-11-12	12	02/14/08	0.0398 U	0.0663 U	0.0663 U	0.133 U	NA	6.63 U	12.3 U	30.7 U	24.8 UU
EX-B11-T-7-12	12	01/22/08	0.0310	0.0851	0.103	0.532	0.00891	48.4 JZ	52.3	29.6 U	116 J
EX-B11-T-7-WSW-5	5	01/18/08	0.0290 U	0.0484 U	0.0484 U	0.0967 U	NA	9.95 JZ	10.9 U	27.2 U	29.0 J
EX-B11-T-8-12	12	01/30/08	0.231	0.561	0.150	0.778	NA	6.50	11.9 U	29.9 U	27.4
EX-B11-T-9-12	12	02/12/08	0.193	0.0636 U	0.0647	0.127 U	NA	6.36 U	12.5 U	31.4 U	25.1 UU
EX-B11-T-10-10	10	02/14/08	0.0342 U	0.0570 U	0.0570 U	0.114 U	NA	5.70 U	12.3 U	30.6 U	24.3 UU
EX-B11-T-11-12	12	02/14/08	0.0306 U	0.0510 U	0.0510 U	0.102 U	NA	5.10 U	11.7 U	29.2 U	23.0 UU
EX-B11-T-11-ESW-6	6	02/15/08	0.0382 U	0.0637 U	0.0637 U	0.127 U	NA	6.37 U	12.5 U	31.4 U	25.1 UU
EX-B11-U-7-5	5	01/18/08	0.0290 U	0.0484 U	0.0484 U	0.0967 U	NA	4.84 U	11.0 U	27.5 U	21.7 UU
EX-B11-U-8-14	14	01/30/08	2.59	3.57	1.59	7.94	NA	48.6	11.9 U	29.7 U	69.4
EX-B11-U-9-12	12	01/31/08	0.461	0.824	0.460	1.71	NA	15.8	12.1 U	30.3 U	37.0
EX-B11-U-10-10	10	02/14/08	1.20	0.0890 U	0.0890 U	0.178 U	NA	8.90 U	14.0 U	34.9 U	28.9 UU
EX-B11-U-10-SSW-5	5	02/12/08	14.9	0.606 U	1.48	1.21 U	0.159	214	957 Q4	639 Q4	1,810
EX-B11-U-11-5	5	02/12/08	0.0429 U	0.0716 U	0.0716 U	0.143 U	0.0260	8.80 JZ	423 Q4	131 Q4	563 J
EX-B11-V-8-5	5	01/31/08	0.127	0.219	0.196	0.218	0.0172	175 JZ	616	28.0 U	805 J
EX-B11-V-9-5	5	01/31/08	0.142 J	0.302 J	1.17 J	2.36 J	0.00872	405 JZ	265	84.4	754 J
EX-B13-AA-2-10	10	09/26/07	0.0346	0.0564 U	0.0564 U	0.113 U	NA	12.8	12.5 U	31.1 U	34.6
EX-B13-AA-2-NSW-4	4	09/19/07	0.0306 U	0.0511 U	0.0511 U	0.102 U	0.0126	5.11 U	35.2	101	139
EX-B13-AA-2-WSW-4	4	09/19/07	0.0303 U	0.0505 U	0.0505 U	0.101 U	NA	5.05 U	11.0 U	27.5 U	21.8 UU
EX-B13-AA-3-10	10	09/26/07	0.0322 U	0.0537 U	0.0537 U	0.107 U	NA	5.37 U	12.9 U	32.2 U	25.2 UU
EX-B13-AA-3-NSW-4	4	09/19/07	0.0265 U	0.0441 U	0.0441 U	0.0883 U	NA	4.41 U	10.5 U	26.2 U	20.6 UU
EX-B13-AA-4-10	10	09/26/07	0.0313 U	0.0522 U	0.0522 U	0.104 U	NA	5.22 U	11.7 U	29.2 U	23.1 UU
EX-B13-BB-2-10	10	09/25/07	0.0336 U	0.0560 U	0.0560 U	0.112 U	NA	5.60 U	11.8 U	29.5 U	23.5 UU
EX-B13-BB-2-WSW-4	4	09/19/07	0.476	0.959	0.993	1.12	0.0335	774 JZ	1,030 J	105 J	1,910 J
EX-B13-BB-3-10	10	09/25/07	0.0281 U [0.0319 U]	0.0468 U [0.0532 U]	0.0468 U [0.0532 U]	0.0935 U [0.106 U]	NA [NA]	4.98 U [5.32 U]	10.7 U [11.5 U]	26.7 U [28.8 U]	21.2 UU [22.8 UU]
EX-B13-BB-4-10	10	09/25/07	0.0283 U	0.0472 U	0.0472 U	0.0945 U	NA	4.72 U	12.7 U	31.8 U	24.6 UU
EX-B13-BB-5-10	10	09/27/07	0.0295 U	0.0491 U	0.0491 U	0.0983 U	NA	4.91 U	11.4 U	28.5 U	22.4 UU
EX-B13-CC-1-4	4	10/10/07	0.0432 U	0.104	0.0720 U	0.144 U	NA	20.2	18.4 U	45.9 U	52.4
EX-B13-CC-1-10	10	10/08/07	0.952	3.90	2.99	2.51	0.0881	1,630	3,810 J	656 J	6,100 J
EX-B13-CC-2-4	4	09/25/07	8.83	4.68 U	4.68 U	9.37 U	0.0499	3,020	2,520	582	6,120
EX-B13-CC-2-10	10	10/08/07	0.0278 U	0.0463 U	0.0463 U	0.0926 U	NA	4.63 U	11.3 U	28.1 U	22.0 UU
EX-B13-CC-3-10	10	09/27/07	0.0285 U	0.0475 U	0.0475 U	0.0951 U	NA	4.75 U	12.1 U	30.2 U	23.5 UU
EX-B13-CC-4-10	10	09/27/07	0.0279 U	0.0465 U	0.0465 U	0.0931 U	NA	4.65 U	12.0 U	30.1 U	23.4 UU
EX-B13-CC-5-10	10	09/27/07	0.0299 U	0.0498 U	0.0498 U	0.0997 U	NA	4.98 U	12.5 U	31.2 U	24.3 UU
EX-B13-DD-1-4	4	10/08/07	0.0408 U	0.0679 U	0.0679 U	0.136 U	NA	6.79 U	14.7 U	36.7 U	29.1 UU
EX-B13-DD-2-10	10	10/08/07	0.0291 U	0.0484 U	0.0484 U	0.0968 U	NA	4.84 U	11.8 U	29.5 U	23.1 UU
EX-B13-DD-3-10	10	10/02/07	0.0279 U	0.0465 U	0.0465 U	0.0929 U	NA	4.65 U	11.1 U	27.8 U	21.8 UU
EX-B13-DD-4-10	10	10/02/07	0.173	0.0461 U	0.0461 U	0.0921 U	NA	4.61	11.7 U	29.1 U	25.0
EX-B13-DD-5-10	10	10/02/07	0.0637	0.0451 U	0.0451 U	0.0901 U	NA	4.51 U	11.6 U	28.9 U	22.5 UU
EX-B13-EE-1-4	4	10/08/07	0.0283 U	0.0472 U	0.0472 U	0.0944 U	NA	4.72 U	12.2 U	30.4 U	23.7 UU
EX-B13-EE-2-10	10	10/08/07	0.0272 U	0.0453 U	0.0453 U	0.0905 U	NA	4.53 U	11.6 U	28.9 U	22.5 UU

TABLE 4
Excavation Soil Sample Analytical Results
Unocal Edmonds Bulk Fuel Terminal Lower Yard
Phase I Remedial Implementation As-built Report
11720 Unoco Road
Edmonds, Washington

Sample ID	Sample Depth (feet bgs)	Date Sampled	BTEX (mg/kg)				Total cPAHs Adjusted for Toxicity (mg/kg) CUL = 0.14 mg/kg	Gasoline (mg/kg)	Diesel (mg/kg)	Heavy Oil (Lube) (mg/kg)	Total TPH (mg/kg) REL = 2,975
			B	T	E	X					
			REL = 18 mg/kg								
EX-B13-EE-3-10	10	10/05/07	0.0298 U	0.0496 U	0.0496 U	0.0992 U	NA	4.96 U	11.5 U	28.8 U	22.6 UU
EX-B13-EE-3-SSW-4	4	10/05/07	0.0509	0.0502 U	0.0502 U	0.100 U	NA	6.85	12.2 U	30.6 U	28.3
EX-B13-EE-4-10	10	10/05/07	0.0296 U [0.0292 U]	0.0494 U [0.0487 U]	0.0494 U [0.0487 U]	0.0987 U [0.0974 U]	NA [NA]	4.94 U [4.87 U]	11.7 U [11.1 U]	29.3 U [27.8 U]	23.0 UU [21.9 UU]
EX-B13-EE-4-SSW-4	4	10/05/07	0.0314 U	0.0523 U	0.0523 U	0.105 U	NA	5.23 U	12.6 U	31.5 U	24.7 UU
EX-B13-FF-2-4	4	10/09/07	0.0302 U	0.0504 U	0.0504 U	0.101 U	NA	5.04 U	12.8 U	32.0 U	24.9 UU
EX-B13-FF-3-10	10	10/09/07	0.0447	0.0538 U	0.0538 U	0.108 U	NA	8.17	11.7 U	29.4 U	28.7
EX-B13-FF-3-ESW-4	4	10/09/07	0.0289 U	0.0481 U	0.0481 U	0.0963 U	NA	4.81 U	12.7 U	31.8 U	24.7 UU
EX-B13-GG-3-4	4	10/09/07	0.136	0.0462 U	0.0462 U	0.0925 U	NA	4.62 U	12.9 U	32.2 U	24.9 UU
EX-B14-DD-7-2.5	2.5	08/23/07	1.85	0.0664 U	0.0844	0.133 U	0.0121	70.6	151	82.0	304
EX-B14-DD-7-WSW-2.5	2.5	09/10/07	14.6	2.94	7.66	8.28	0.0111	2,940 J	3,640 J	213	6,790 J
EX-B14-DD-8-5	5	08/23/07	0.0500 [0.0302 U]	0.0519 U [0.0504 U]	0.0519 U [0.0504 U]	0.104 U [0.101 U]	0.226 [0.222]	40.3 JZ [23.3 JZ]	990 Q4 [425 Q4]	861 Q4 [396 Q4]	1,890 J [844 J]
EX-B14-DD-8-6	6	09/04/07	0.0999 [0.0912]	0.0496 U [0.0507 U]	0.0549 [0.0507 U]	0.0993 U [0.101 U]	0.00945 [0.00929]	13.9 [11.9]	70.8 JQ4 [28.3 JQ4]	75.1 JQ4 [30.9 UQ4]	160 J [71.1 J]
EX-B14-DD-NSW-2.5	2.5	08/23/07	0.0885 J [1.32 J]	0.0509 U [0.0687 U]	0.0509 U [0.0768]	0.102 U [0.137 U]	0.0112 [0.0244]	25.0 [72.9 JZ]	157 Q4 [188]	83.6 Q4 [88.7]	266 [350 J]
EX-B14-EE-5-4	4	09/10/07	0.404	0.0701 U	0.662	0.800	NA	445 JZ	12.1 U	30.3 U	466 J
EX-B14-EE-6-8	8	09/10/07	0.239	0.0541 U	0.0541 U	0.108 U	NA	5.41 U	11.7 U	29.2 U	23.2 UU
EX-B14-EE-7-8	8	08/23/07	0.0581 U	0.0968 U	0.0968 U	0.194 U	NA	9.68 U	17.9 U	44.7 U	36.1 UU
EX-B14-EE-8-4	4	08/23/07	0.255	0.0490 U	0.0490 U	0.0980 U	NA	4.90 U	12.7 U	31.7 U	24.7 UU
EX-B14-EE-WSW-4	4	08/23/07	2.30	0.539 U	4.91	7.39	0.224	1,040 JZ	3,290 J	598 UJ	4,630 J
EX-B14-FF-6-4	4	09/07/07	0.213	0.0536 U	0.0536 U	0.107 U	NA	5.57	12.6 U	31.4 U	27.6
EX-B14-FF-7-8	8	08/23/07	0.0763 U	0.127 U	0.127 U	0.254 U	NA	12.7 U	20.1 U	50.3 U	41.6 UU
EX-B14-FF-8-4SW	4	08/22/07	0.0505 U	0.0841 U	0.0841 U	0.168 U	0.0119	8.41 U	523	144	671
EX-B14-FF-WSW-4	4	08/23/07	0.100	0.0489 U	0.0489 U	0.0977 U	0.0107	16.3	64.2	34.6	115
EX-B14-GG-7-8	8	08/23/07	0.0266 U	0.0444 U	0.0444 U	0.0888 U	NA	4.44 U	12.1 U	30.4 U	23.5 UU
EX-B14-GG-WSW-4	4	08/23/07	0.0275 U	0.0458 U	0.0458 U	0.0915 U	0.0218	8.72	428 Q4	138 Q4	575
EX-B14-HH-6-4	4	08/23/07	0.0302 U [0.0285 U]	0.0504 U [0.0475 U]	0.0504 U [0.0475 U]	0.101 U [0.0949 U]	0.0107 [0.0107]	5.04 U [4.75 U]	40.1 Q4 [44.6 Q4]	80.6 Q4 [90.5 Q4]	123 [137]
EX-B14-HH-6F	6	08/23/07	0.0260 U	0.0433 U	0.0433 U	0.0866 U	0.0110	4.33 U	38.3 Q12	29.4 U	55.2
EX-B14-HH-7-4SW	4	08/23/07	0.0277 U	0.0461 U	0.0461 U	0.0923 U	0.0117	9.66 JZ	29.1 JY	29.5 U	53.5 J
EX-B15-HH-2-4	4	08/28/07	0.0901	0.0563 U	0.0563 U	0.184	NA	5.63 U	13.2 U	33.0 U	25.9 UU
EX-B15-HH-3-ESW-4	4	08/28/07	0.0319 U	0.0532 U	0.0532 U	0.106 U	NA	5.32 U	11.9 U	29.8 U	23.5 UU
EX-B15-HH-3-NSW-4	4	08/28/07	0.356	0.0539 U	0.0539 U	0.108 U	NA	5.39 U	13.0 U	32.4 U	25.4 UU
EX-B15-II-2-8	8	08/28/07	0.0571	0.0789 U	0.0789 U	0.158 U	NA	12.6	15.4 U	38.4 U	39.5
EX-B15-II-2-WSW-4	4	08/28/07	1.10	0.0517 U	0.143	0.133	NA	29.2	12.9 U	32.4 U	51.9
EX-B15-II-3-8	8	08/28/07	0.0264 U	0.0440 U	0.0440 U	0.0880 U	NA	4.40 U	11.6 U	29.1 U	22.6 UU
EX-B15-II-4-ESW-4	4	08/28/07	0.0316 U	0.0527 U	0.0527 U	0.169	0.0115	209 JZ	676	153	1,040 J
EX-B16-MM-1-6SW	6	08/20/07	0.305 U	0.508 U	0.807	1.02 U	0.00911	293 JZ	656	78.3 Q7	1,030 J
EX-B17-RR-1-6SW	6	08/20/07	0.0488 U	0.0814 U	0.0814 U	0.163 U	0.0113	8.14 U	51.2 JY	72.5 J	128 J
EX-B17-SS-1-6SW	6	08/20/07	0.0270 U	0.0450 U	0.0450 U	0.0900 U	NA	4.50 U	12.0 U	30.1 U	23.3 UU
EX-B18-UU-1-6SW	6	08/17/07	0.290 U [0.288 U]	0.484 U [0.480 U]	0.691 [0.554]	2.55 [1.94]	0.0435 [0.0103]	693 JZ [611 JZ]	1,140 J [376 J]	146 U [58.5 U]	1,910 J [1,020 J]
EX-B18-VV-1-6SW	6	08/17/07	1.56 U	2.60 U	2.60 U	5.82	0.0457	2,150 JZ	2,670 J	312 U	4,980 J
EX-B20-O-14-12	12	01/18/08	0.0303 U	0.0505 U	0.0505 U	0.101 U	NA	5.05 U	12.1 U	30.1 U	23.6 UU
EX-B20-O-15-12	12	01/18/08	0.0299 U	0.0499 U	0.0499 U	0.0998 U	NA	4.99 U	12.4 U	31.1 U	24.2 UU
EX-B20-F-19-6	6	10/18/07	0.0538	0.0521 U	0.0763	0.320	NA	23.0	12.4 U	31.1 U	44.8
EX-B20-F-19-NSW-3	3	10/26/07	0.0271 U	0.0451 U	0.0451 U	0.0902 U	NA	4.51 U	11.1 U	27.8 U	21.7 UU
EX-B20-F-20-10	10	10/30/07	0.0290 U	0.0484 U	0.0484 U	0.0968 U	0.0230	4.84 U	53.4	31.1 U	71.4
EX-B20-F-20-NSW-4	4	10/30/07	0.0286 U [0.0292 U]	0.0476 U [0.0486 U]	0.0476 U [0.0486 U]	0.0952 U [0.0972 U]	NA [NA]	4.76 U [4.86 U]	11.1 U [11.3 U]	27.8 U [28.3 U]	21.8 UU [22.2 UU]
EX-B20-F-21-4	4	10/17/07	0.0316 U	0.0526 U	0.0526 U	0.105 U	NA	5.26 U	12.0 U	30.0 U	23.6 UU
EX-B20-G-13-12	12	11/26/07	0.0268 U	0.0447 U	0.0447 U	0.0895 U	0.00823	4.47 U	100 J	27.3 U	116 J
EX-B20-G-14-12	12	11/20/07	0.0292 U	0.0486 U	0.0486 U	0.0973 U	NA	4.86 U	12.1 U	30.3 U	23.6 UU
EX-B20-G-14-WSW-4	4	11/20/07	0.0299 U	0.0498 U	0.0498 U	0.0995 U	0.00815	4.98 U	48.5 Q11	32.9	83.9
EX-B20-G-18-15	15	10/18/07	0.0276 U	0.0460 U	0.0460 U	0.0919 U	NA	5.04 U	12.1 U	30.3 U	23.7 UU
EX-B20-G-19-15	15	10/18/07	0.0377 U	0.0628 U	0.0628 U	0.126 U	NA	6.28 U	12.0 U	30.1 U	24.2 UU
EX-B20-G-20-15	15	10/18/07	0.0365	0.0488 U	0.179	0.0976 U	NA	4.88 U	11.8 U	29.4 U	23.0 UU
EX-B20-G-21-10	10	10/17/07	0.271 U	0.792	0.451 U	0.903 U	0.00944	123 JZ	1,020	59.0	1,200 J
EX-B20-G-21-ESW-5	5	10/26/07	0.0273 U	0.0455 U	0.0455 U	0.0910 U	0.00891	4.55 U	36.0 C8	29.3 U	52.9

TABLE 4
Excavation Soil Sample Analytical Results
Unocal Edmonds Bulk Fuel Terminal Lower Yard
Phase I Remedial Implementation As-built Report
11720 Unoco Road
Edmonds, Washington

Sample ID	Sample Depth (feet bgs)	Date Sampled	BTEX (mg/kg)				Total cPAHs Adjusted for Toxicity (mg/kg) CUL = 0.14 mg/kg	Gasoline (mg/kg)	Diesel (mg/kg)	Heavy Oil (Lube) (mg/kg)	Total TPH (mg/kg) REL = 2,975
			B	T	E	X					
			REL = 18 mg/kg								
EX-B20-H-10-4	4	11/30/07	0.0291 U	0.0484 U	0.0484 U	0.0968 U	0.00858	4.84 U	148 Q4	195 Q4	345
EX-B20-H-11-4	4	11/29/07	0.0298 U	0.0497 U	0.0497 U	0.0994 U	NA	4.97 U	11.0 U	27.5 U	21.7 UU
EX-B20-H-12-6	6	11/29/07	0.0284 U [0.0291 U]	0.0473 U [0.0485 U]	0.0473 U [0.0485 U]	0.0946 U [0.0970 U]	0.00823 [0.00831]	4.73 U [4.85 U]	28.9 Q11 [35.8 Q11]	27.4 U [27.6 U]	45.0 [52.0]
EX-B20-H-12-NSW-2	2	11/29/07	0.0262 U	0.0437 U	0.0437 U	0.0873 U	NA	4.37 U	11.3 U	28.3 U	22.0 UU
EX-B20-H-13-12	12	11/26/07	0.0330 U	0.0550 U	0.0550 U	0.110 U	NA	5.50 U	12.3 U	30.7 U	24.3 UU
EX-B20-H-14-12	12	11/20/07	0.0319 U	0.0531 U	0.0531 U	0.106 U	0.00959	5.31 U	70.9 Q11	31.6 U	89.4
EX-B20-H-14-WSW-4	4	11/20/07	0.0277 U [0.0306 U]	0.0461 U [0.0510 U]	0.0461 U [0.0510 U]	0.0922 U [0.102 U]	0.00876 [0.00846]	4.61 U [5.10 U]	27.1 Q11 [20.4 Q11]	28.5 U [27.6 U]	43.7 [36.8]
EX-B20-H-18-15	15	10/18/07	0.0299 U [0.0301 U]	0.0498 U [0.0502 U]	0.0498 U [0.0502 U]	0.0997 U [0.100 U]	NA [NA]	4.98 U [5.02 U]	12.0 U [12.2 U]	30.0 U [30.5 U]	23.5 UU [23.9 UU]
EX-B20-H-19-15	15	10/18/07	0.0276 U	0.0460 U	0.0689	0.0920 U	NA	4.60 U	12.1 U	30.2 U	23.5 UU
EX-B20-H-20-15	15	10/18/07	0.107	0.0671 U	0.474	0.378	NA	10.5	13.8 U	34.5 U	34.7
EX-B20-H-21-10	10	10/18/07	0.0683 U	0.114 U	0.114 U	0.228 U	0.0153	11.4 U	506	72.1	584
EX-B20-H-21-ESW-5	5	10/26/07	0.0271 U	0.0452 U	0.0452 U	0.0903 U	0.00891	7.14 JZ	58.7 J	29.1 U	80.4 J
EX-B20-I-9-9	9	10/17/07	0.0440 U	0.0733 U	0.0733 U	0.147 U	NA	7.33 U	15.6 U	39.1 U	31.0 UU
EX-B20-I-10-10	10	11/29/07	0.0308 U	0.0514 U	0.0514 U	0.103 U	NA	5.14 U	12.7 U	31.8 U	24.8 UU
EX-B20-I-11-10	10	11/29/07	0.0329 U	0.0549 U	0.0549 U	0.110 U	NA	7.89	12.2 U	30.6 U	29.3
EX-B20-I-11-NSW-6	6	11/29/07	0.0299 U	0.0499 U	0.0499 U	0.0997 U	0.00815	5.84 JZ	63.6 Q11	26.9 U	82.9 J
EX-B20-I-12-10	10	11/29/07	0.0296 U	0.0493 U	0.0493 U	0.0985 U	NA	5.87	12.4 U	31.0 U	27.6
EX-B20-I-13-12	12	11/26/07	0.0291 U	0.0485 U	0.0485 U	0.0971 U	NA	4.85 U	11.8 U	29.4 U	23.0 UU
EX-B20-I-14-12	12	11/20/07	0.0314 U	0.0524 U	0.0524 U	0.105 U	NA	5.24 U	13.0 U	32.5 U	25.4 UU
EX-B20-I-15-15	15	11/05/07	0.0315 U	0.0525 U	0.0525 U	0.105 U	NA	5.25 U	13.6 U	34.0 U	26.4 UU
EX-B20-I-18-15	15	10/19/07	0.0392	0.0498 U	0.156	0.0997 U	NA	4.98 U	12.6 U	31.6 U	24.6 UU
EX-B20-I-19-15	15	10/18/07	0.0361 U [0.0326 U]	0.0601 U [0.0543 U]	0.0601 U [0.0543 U]	0.120 U [0.109 U]	NA [NA]	6.01 U [5.43 U]	13.3 U [13.1 U]	33.2 U [32.9 U]	26.3 UU [25.7 UU]
EX-B20-I-20-8	8	10/18/07	0.0303 U	0.0505 U	0.0505 U	0.101 U	NA	5.05 U	12.7 U	31.7 U	24.7 UU
EX-B20-I-21-4	4	10/30/07	0.0254 U	0.0423 U	0.0423 U	0.0846 U	0.0231	4.83 JZ	37.8	49.7	92.3 J
EX-B20-J-9-9	9	10/17/07	0.0310 U	0.0517 U	0.0517 U	0.103 U	0.00906	37.0 JZ	12.9	29.8 U	64.8 J
EX-B20-J-10-10	10	11/29/07	0.0340 U	0.0945	0.0567 U	0.123	NA	18.1	12.7 U	31.8 U	40.4
EX-B20-J-11-11	11	12/13/07	0.0301 U	0.0502 U	0.0502 U	0.100 U	NA	5.02 U	12.6 U	31.6 U	24.6 UU
EX-B20-J-12-10	10	11/28/07	0.0329	0.0539 U	0.0539 U	0.108 U	NA	5.39 U	12.3 U	30.8 U	24.2 UU
EX-B20-J-13-12	12	11/26/07	0.0304 U	0.0507 U	0.0507 U	0.101 U	NA	5.07 U	12.2 U	30.4 U	23.8 UU
EX-B20-J-14-12	12	11/20/07	0.0302 U	0.0503 U	0.0503 U	0.101 U	0.00891	5.03 U	29.6 Q11	29.3 U	46.8
EX-B20-J-15-15	15	11/05/07	0.0346 U	0.0577 U	0.0577 U	0.115 U	NA	5.77 U	13.2 U	32.9 U	25.9 UU
EX-B20-J-18-15	15	10/19/07	0.0293 U	0.0489 U	0.0489 U	0.0978 U	NA	4.89 U	12.2 U	30.5 U	23.8 UU
EX-B20-J-20-4	4	10/30/07	0.0355 U	0.0592 U	0.0592 U	0.118 U	NA	5.92 U	13.9 UC	34.8 U	34.3
EX-B20-K-7-5	5	01/10/08	0.0349 U	0.0918	0.0928	0.416	0.00936	65.1 JZ	16.1 JY	41.1	122 J
EX-B20-K-9-9	9	10/16/07	0.0385 U	0.0642 U	0.0642 U	0.128 U	NA	8.19	12.3 U	30.9 U	29.8
EX-B20-K-10-10	10	11/30/07	0.0315 U	0.0525 U	0.0525 U	0.105 U	NA	5.25 U	12.9 U	32.3 U	25.2 UU
EX-B20-K-11-10	10	11/29/07	0.0290 U	0.0483 U	0.0483 U	0.0967 U	NA	4.83 U	12.4 U	31.0 U	24.1 UU
EX-B20-K-12-12	12	11/29/07	0.0310 U	0.0517 U	0.0517 U	0.103 U	NA	5.17 U	12.8 U	32.1 U	25.0 UU
EX-B20-K-13-12	12	11/26/07	0.0305 U	0.0508 U	0.0508 U	0.102 U	NA	5.08 U	13.1 U	32.8 U	25.5 UU
EX-B20-K-14-12	12	11/20/07	0.0283 U	0.0471 U	0.0471 U	0.0943 U	NA	4.71 U	12.3 U	30.8 U	23.9 UU
EX-B20-K-15-15	15	11/05/07	0.0282 U	0.0470 U	0.0470 U	0.0940 U	NA	4.70 U	12.2 U	30.5 U	23.7 UU
EX-B20-K-16-15	15	10/31/07	0.0279 U	0.0466 U	0.0466 U	0.0932 U	NA	4.66 U	12.4 U	31.0 U	24.0 UU
EX-B20-L-7-5	5	02/08/08	0.0256 U	0.0427 U	0.128	0.217	0.00956	41.3 JZ	84.8	64.8	191 J
EX-B20-L-8-10	10	12/11/07	0.0337 U	0.0561 U	0.0561 U	0.112 U	NA	6.07	13.7 U	34.1 U	30.0

TABLE 4
Excavation Soil Sample Analytical Results
Unocal Edmonds Bulk Fuel Terminal Lower Yard
Phase I Remedial Implementation As-built Report
11720 Unoco Road
Edmonds, Washington

Sample ID	Sample Depth (feet bgs)	Date Sampled	BTEX (mg/kg)				Total cPAHs Adjusted for Toxicity (mg/kg) CUL = 0.14 mg/kg	Gasoline (mg/kg)	Diesel (mg/kg)	Heavy Oil (Lube) (mg/kg)	Total TPH (mg/kg) REL = 2,975
			B	T	E	X					
			REL = 18 mg/kg								
EX-B20-L-8-WSW5	5	01/07/08	0.0410 [0.0430]	0.123 [0.142]	0.0586 U [0.0651]	0.131 [0.110 U]	0.0104 [0.00973]	26.8 JZ [36.4 JZ]	107 Q4 [154 Q4]	81.4 JQ4 [202 JQ4]	215 J [392 J]
EX-B20-L-9-10	10	12/11/07	0.0320 U	0.0534 U	0.0534 U	0.107 U	NA	5.34 U	12.8 U	31.9 U	25.0 UU
EX-B20-L-10-10	10	11/30/07	0.0310 U	0.0516 U	0.0516 U	0.103 U	NA	5.16 U	12.6 U	31.4 U	24.6 UU
EX-B20-L-11-10	10	12/07/07	0.0322 U	0.0537 U	0.0537 U	0.107 U	NA	5.37 U	13.1 U	32.7 U	25.6 UU
EX-B20-L-12-12	12	11/29/07	0.0321 U	0.0536 U	0.0536 U	0.107 U	NA	5.36 U	12.1 U	30.3 U	23.9 UU
EX-B20-L-13-12	12	11/26/07	0.0295 U	0.0492 U	0.0492 U	0.0983 U	NA	4.92 U	12.8 U	32.0 U	24.9 UU
EX-B20-L-14-12	12	11/20/07	0.0292 U	0.0486 U	0.0486 U	0.0972 U	NA	4.86 U	12.2 U	30.5 U	23.8 UU
EX-B20-L-15-15	15	11/05/07	0.0282 U	0.0471 U	0.0471 U	0.0941 U	NA	4.71 U	12.3 U	30.8 U	23.9 UU
EX-B20-L-16-15	15	10/31/07	0.0297 U	0.0496 U	0.0496 U	0.0992 U	NA	4.96 U	12.7 U	31.7 U	24.7 UU
EX-B20-M-6-5	5	02/08/08	0.778 J	0.278 U	13.8 J	40.1 J	0.103	4,630 JZ	5,250 JQ10	7,070 J	17,000 J
EX-B20-M-7-10	10	02/08/08	0.0376 U	0.0627 U	0.0627 U	0.125 U	NA	6.27 U	12.0 U	29.9 U	24.1 UU
EX-B20-M-8-12	12	01/16/08	0.0297 U	0.0495 U	0.0495 U	0.0990 U	NA	9.22	11.9 U	29.8 U	30.1
EX-B20-M-9-12	12	01/16/08	0.0319 U	0.0532 U	0.0532 U	0.106 U	NA	9.88	12.3 U	30.8 U	31.4
EX-B20-M-10-12	12	12/07/07	0.0363	0.0534 U	0.0534 U	0.107 U	NA	8.72	12.5 U	31.2 U	30.6
EX-B20-M-11-12	12	12/07/07	0.0314 U	0.0523 U	0.0523 U	0.105 U	NA	5.23 U	12.7 U	31.7 U	24.8 UU
EX-B20-M-12-12	12	12/07/07	0.0299 U [0.0310 U]	0.0498 U [0.0517 U]	0.0498 U [0.0517 U]	0.0997 U [0.103 U]	NA [NA]	4.98 U [5.17 U]	11.5 U [11.0 U]	28.9 U [27.4 U]	22.7 UU [21.8 UU]
EX-B20-M-13-14	14	12/07/07	0.0332 U	0.0554 U	0.0554 U	0.111 U	NA	5.54 U	13.8 U	34.5 U	26.9 UU
EX-B20-M-14-11	11	12/07/07	0.0306 U	0.0510 U	0.0510 U	0.102 U	NA	5.10 U	11.9 U	29.7 U	23.4 UU
EX-B20-M-15-11	11	12/07/07	0.0316 U	0.0527 U	0.0527 U	0.105 U	NA	5.27 U	11.5 U	28.8 U	22.8 UU
EX-B20-M-16-15	15	11/09/07	0.0302 U	0.0504 U	0.0504 U	0.101 U	NA	5.04 U	11.9 U	29.8 U	23.4 UU
EX-B20-M-16-SSW-12	12	11/09/07	0.0298 U	0.0497 U	0.0497 U	0.0995 U	NA	4.97 U	10.8 U	26.9 U	21.3 UU
EX-B20-M-17-10	10	11/09/07	0.0297 U	0.0495 U	0.0495 U	0.0989 U	NA	4.95 U	12.0 U	30.0 U	23.5 UU
EX-B20-M-17-ESW-5	5	11/09/07	0.0303 U	0.0505 U	0.0505 U	0.101 U	NA	5.05 U	12.4 U	30.9 U	24.2 UU
EX-B20-M-17-SSW-4	4	11/09/07	1.09	0.504 U	0.504 U	1.04	0.412	1,090 JZ	13,000	271 UQ7	14,400 J
EX-B20-M-17-SSW-6	6	01/28/08	0.577	0.529 U	0.529 U	1.21	0.166	1,380 Q10a	13,600 J	1,380 UJ	15,700 J
EX-B20-N-7-8	8	01/16/08	0.0324 U	0.0540 U	0.0540 U	0.108 U	NA	8.29	11.9 U	29.7 U	29.1
EX-B20-N-7-WSW-4	4	01/16/08	0.0293 U	0.0489 U	0.0489 U	0.0978 U	0.0152	33.5 JZ	148 Q4	125 Q4	307 J
EX-B20-N-8-12	12	01/16/08	0.0318 U	0.0530 U	0.0530 U	0.106 U	NA	5.30 U	12.8 U	31.9 U	25.0 UU
EX-B20-N-9-12	12	01/16/08	0.0313 U	0.0521 U	0.0521 U	0.104 U	NA	5.21 U	12.6 U	31.6 U	24.7 UU
EX-B20-N-10-12	12	01/08/08	0.0292 U	0.0487 U	0.0487 U	0.0974 U	NA	4.87 U	11.7 U	29.2 U	22.9 UU
EX-B20-N-11-12	12	01/08/08	0.0292 U	0.0487 U	0.0487 U	0.0975 U	NA	5.56	12.1 U	30.2 U	26.7
EX-B20-N-12-12	12	01/08/08	0.0282 U	0.0470 U	0.0470 U	0.0941 U	NA	4.70 U	11.9 U	29.9 U	23.3 UU
EX-B20-N-13-12	12	01/08/08	0.0310 U	0.0517 U	0.0517 U	0.103 U	NA	5.17 U	12.4 U	31.0 U	24.3 UU
EX-B20-N-14-12	12	12/11/07	0.0308 U	0.0513 U	0.0513 U	0.103 U	NA	5.13 U	12.3 U	30.7 U	24.1 UU
EX-B20-N-15-12	12	12/11/07	0.0338 U	0.0563 U	0.0563 U	0.113 U	NA	5.63 U	13.1 U	32.7 U	25.7 UU
EX-B20-N-16-4	4	11/09/07	2.02	1.74	2.41	2.52	0.409	2,120 JZ	14,700	312 Q7	17,100 J
EX-B20-N-16-12	12	11/13/07	0.0322 U	0.0537 U	0.0537 U	0.107 U	NA	5.37 U	11.6 U	29.1 U	23.0 UU
EX-B21-ESW-2	2	10/11/07	0.0354 U	0.0591 U	0.0591 U	0.118 U	NA	5.91 U	11.0 U	27.5 U	22.2 UU
EX-B21-FLOOR-4	4	10/11/07	0.0303 U	0.0506 U	0.0506 U	0.101 U	NA	5.06 U	11.8 U	29.5 U	23.2 UU
EX-B21-NSW-2	2	10/11/07	0.0300 U	0.0500 U	0.0500 U	0.100 U	0.00883	5.00 U	12.4 JY	44.6	59.5 J
EX-SDTI-5-NSW-4	4	08/22/07	0.0320 U	0.0533 U	0.0533 U	0.107 U	NA	5.33 U	12.8 U	31.9 U	25.0 UU
EX-SDTI-5-SSW-4	4	08/22/07	0.0344 U	0.0574 U	0.0574 U	0.115 U	NA	5.74 U	13.0 U	32.4 U	25.6 UU
EX-SDTI-ESW-4	4	08/22/07	0.0400 U	0.0667 U	0.0667 U	0.133 U	0.0107	6.67 U	30.1 Q11	35.6 U	51.2
EX-SDTI-FF-S-8	8	08/22/07	0.0333 U	0.0556 U	0.0556 U	0.111 U	0.00951	5.56 U	32.3 Q11	64.7	99.8
EX-SDTI-GG-ESW-4	4	08/22/07	0.0304 U	0.0507 U	0.0507 U	0.101 U	NA	5.07 U	12.3 U	30.6 U	24.0 UU
EX-SDTI-GG-S-8	8	08/22/07	0.0286 U	0.0477 U	0.0477 U	0.0953 U	0.00936	4.77 U	12.1 U	42.4	50.8
EX-SDTI-GG-WSW-4	4	08/22/07	0.0322 U	0.0537 U	0.0537 U	0.107 U	0.00929	5.37 U	36.8 Q11	31.5 U	55.2
EX-SDTI-WSW-4	4	08/22/07	0.0757	0.0580 U	0.0580 U	0.116 U	NA	9.40	12.2 U	30.6 U	30.8
EX-WW-G-27-2SW	2	08/07/07	0.0287 U	0.0479 U	0.0479 U	0.0958 U	0.00924	4.79 U	14.9 JY	49.7	67.0 J
EX-WW-G-27-4	4	08/07/07	0.0299 U	0.0498 U	0.0498 U	0.0997 U	NA	4.98 U	10.9 U	27.3 U	21.6 UU
EX-WW-H-27-2.5	2.5	08/07/07	0.0384 U	0.0639 U	0.0639 U	0.128 U	0.0321	6.39 U	16.4 JY	60.0	79.6 J
EX-WW-H-28-2	2	08/07/07	0.0294 U	0.0491 U	0.0491 U	0.0981 U	0.00891	6.07	21.4 JY	68.1	95.6 J
EX-WW-H-29-1	1	08/07/07	0.0335 U	0.0559 U	0.0559 U	0.112 U	0.00808	4.59 U	20.0 JY	78.9	101 J
EX-WW-I-26-1	1	08/07/07	0.0254 U	0.0424 U	0.0424 U	0.0848 U	0.00934	4.24 U	12.3 JY	44.3	58.7 J

TABLE 4
Excavation Soil Sample Analytical Results
 Unocal Edmonds Bulk Fuel Terminal Lower Yard
 Phase I Remedial Implementation As-built Report
 11720 Unoco Road
 Edmonds, Washington

Sample ID	Sample Depth (feet bgs)	Date Sampled	BTEX (mg/kg)				Total cPAHs Adjusted for Toxicity (mg/kg)	Gasoline (mg/kg)	Diesel (mg/kg)	Heavy Oil (Lube) (mg/kg)	Total TPH (mg/kg)
			B	T	E	X					
			REL = 18 mg/kg				CUL = 0.14 mg/kg				REL = 2,975
P-B15-NE-SW	4	08/16/07	0.598	0.692	2.35	2.87	NA	874 J	763 JX	637	2,270 J
P-B15-NW-SW	4	08/16/07	8.73	5.36 U	63.5	18.5	NA	6,610	1,910 JX	580 UJ	8,810 J

Notes:

BTEX analyzed by EPA Method 8021B.

cPAHs analyzed by EPA Method 8270 SIM.

Gasoline analyzed by method NWTPH-G.

Diesel and Heavy Oil (Lube) analyzed by method NWTPH-D Extended.

Total TPH calculated by summing the concentrations of gasoline, diesel and heavy oil. If one or more TPH constituents were reported as Non-Detect, half of the reporting limit value was added to the total.

cPAHs adjusted for toxicity according to WAC 173-340-708(8) and *Air Toxics Hot Spots Program Risk Assessment Guidelines, Part II Technical Support Document for Describing Available Cancer Potency Factors*. Office of Environmental Health Hazard Assessment, California EPA, May 2005. If one or more adjusted cPAH constituents were reported as Non-Detect, half of the reporting limit was used in calculations.

Highlighted cells indicate concentration exceeds REL or CUL.

[] = Bracketed data indicate duplicate sample.

feet bgs = Feet below ground surface

BTEX = Benzene, toluene, ethylbenzene, and total xylenes

mg/kg = Milligrams per kilogram

cPAHs = Carcinogenic polyaromatic hydrocarbons

TPH = Total petroleum hydrocarbons

REL = Remediation level

CUL = Cleanup level

NA = Not analyzed

EPA = Environmental Protection Agency

Lab Qualifiers	Definition
C	Calibration Verification recovery was above the method control limit for this analyte. Analyte not detected, data not impacted.
C8	Calibration Verification recovery was above the method control limit for this analyte. A high bias may be indicated.
D	Compound quantitated using a secondary dilution.
J	Indicates an estimated value.
JX	Results in the diesel organic range are primarily due to overlap from a gasoline range product.
JY	Results in the diesel organics range are primarily due to overlap from a heavy oil range product.
JZ	Detected hydrocarbons in the gasoline range appear to be due to overlap of diesel range hydrocarbons.
Q10	Hydrocarbon pattern most closely resembles a blend of gasoline and diesel range hydrocarbons.
Q10a	Hydrocarbon pattern most closely resembles a blend of gasoline and diesel range hydrocarbons.
Q11	Detected hydrocarbons in the diesel range do not have a distinct diesel pattern and may be due to heavily weathered diesel.
Q12	Detected hydrocarbons in the diesel range do not have a distinct diesel pattern and may be due to heavily weathered diesel or possibly biogenic interference.
Q4	The hydrocarbons present are a complex mixture of diesel range and heavy oil range organics.
Q7	The heavy oil range organics present are due to hydrocarbons eluting primarily in the diesel range.
Q9	Hydrocarbon pattern most closely resembles transformer oil.
U	The compound was analyzed for but not detected. The associated value is the compound quantitation limit.
RL1	Reporting limit raised due to sample matrix effects.
UJ	The compound was analyzed for but not detected. The associated value is the estimated compound quantitation limit.
UU	The constituents making up the total are all non-detects.

TABLE 5
Soil Sample Arsenic Results
 Unocal Edmonds Bulk Fuel Terminal Lower Yard
 Phase I Remedial Implementation As-built Report
 11720 Unoco Road
 Edmonds, Washington

Sample ID	Date Sampled	Sample Depth (feet bgs)	Arsenic (mg/kg)
			CUL = 20 mg/kg
EX-B19-YY-3-1	3/5/2008	1	5.08
EX-B19-YY-2-1	3/5/2008	1	9.84
EX-B19-YY-1-1	3/5/2008	1	5.45
EX-B19-ZZ-1-1	3/5/2008	1	25.0 [30.9]
EX-B19-ZZ-2-1	3/5/2008	1	8.56
EX-B19-ZZ-3-1	3/5/2008	1	5.54
EX-B19-ZZ-1-2	3/7/2008	2	30.7
EX-B19-ZZ-1-2.5	3/12/2008	2.5	<5.54

Notes:

feet bgs = Feet below ground surface

mg/kg = Milligrams per kilogram.

CUL = Cleanup level

[] Indicate Duplicate sample Duplicate samples immediately precede the parent sample.

Highlighted cells indicate concentration exceeds REL or CUL.

Lab Qualifiers	Definition
<	The compound was analyzed for but not detected. The associated value is the compound quantitation limit.

TABLE 8
Confirmation Boring Analytical Results
Unocal Edmonds Bulk Fuel Terminal Lower Yard
Phase I Remedial Implementation As-built Report
11720 Unoco Road
Edmonds, Washington

Sample ID	Date Sampled	Sample Depth (feet bgs)	BTEX (mg/kg)				Total cPAHs Adjusted for Toxicity (mg/kg)	Gasoline (mg/kg)	Diesel (mg/kg)	Heavy Oil (Lube) (mg/kg)	Total TPH (mg/kg)
			B	T	E	X					
			REL = 18 mg/kg				CUL = 0.14 mg/kg				REL = 2,975
SB-1-11.5	04/03/08	11.5	0.0304 U	0.0507 U	0.0507 U	0.101 U	NA	5.07 U	11.4 U	28.6 U	22.5 UU
SB-2-11	04/03/08	11	0.0609 U	0.102 U	0.102 U	0.203 U	NA	10.2 U	15.6 U	38.9 U	32.4 UU
SB-3-10.5	04/03/08	10.5	0.0335 U	0.0559 U	0.0559 U	0.112 U	NA	5.59 U	12.0 U	30.0 U	23.8 UU
SB-3-12	04/03/08	12	0.0372 U	0.0620 U	0.0620 U	0.124 U	NA	6.20 U	11.9 U	29.7 U	23.9 UU
SB-4-10.5	04/04/08	10.5	0.0307 U	0.0511 U	0.0511 U	0.102 U	NA	5.11 U	11.3 U	28.1 U	22.3 UU
SB-5-11.5	04/04/08	11.5	0.0394	0.0513 U	0.0513 U	0.103 U	NA	5.13 U	10.9 U	27.4 U	21.7 UU
SB-6-11.0	04/04/08	11	0.0356 U	0.0594 U	0.0594 U	0.119 U	NA	5.94 U	11.8 U	29.5 U	23.6 UU
SB-7-11.5	04/04/08	11.5	0.0334 U	0.0556 U	0.0556 U	0.111 U	NA	5.56 U	11.5 U	28.8 U	22.9 UU
SB-8-11.0	04/04/08	11	0.0501	0.0505 U	0.0505 U	0.101 U	NA	5.05 U	11.4 U	28.5 U	22.5 UU
SB-9-11.0	04/04/08	11	0.0401	0.0543 U	0.0543 U	0.109 U	NA	5.43 U	11.5 U	28.7 U	22.8 UU
SB-10-11.0	04/04/08	11	0.0341 U [0.0350 U]	0.0569 U [0.0584 U]	0.0569 U [0.0584 U]	0.114 U [0.117 U]	NA [NA]	5.69 U [5.84 U]	11.8 U [11.6 U]	29.6 U [28.9 U]	23.5 UU [23.2 UU]
SB-11-11.0	04/04/08	11	0.0556 U	0.0927 U	0.0927 U	0.185 U	NA	9.27 U	14.2 U	35.5 U	29.5 UU
SB-12-11.5	04/04/08	11.5	0.0348 U	0.0580 U	0.0580 U	0.116 U	NA	5.80 U	12.1 U	30.2 U	24.1 UU
SB-13-11	04/11/08	11	0.0465 U	0.0776 U	0.0776 U	0.155 U	NA	7.76 U	13.1 U	32.8 U	26.8 UU
SB-14-11	04/11/08	11	0.0385 U	0.0642 U	0.0642 U	0.128 U	NA	6.42 U	12.4 U	31.1 U	25.0 UU
SB-15-10.5	04/14/08	10.5	0.0354 U [0.0366 U]	0.0590 U [0.0611 U]	0.0590 U [0.0611 U]	0.118 U [0.122 U]	NA [NA]	5.90 U [6.11 U]	11.9 U [11.9 U]	29.7 U [29.7 U]	23.8 UU [23.9 UU]
SB-16-9.5	04/14/08	9.5	0.0312 U	0.0519 U	0.0519 U	0.104 U	NA	5.19 U	11.1 U	27.6 U	21.9 UU
SB-17-11.5	04/14/08	11.5	0.0321 U	0.0535 U	0.0535 U	0.107 U	NA	5.35 U	11.8 U	29.4 U	23.3 UU
SB-18-11	04/11/08	11	0.711	5.53	4.20	3.24	0.00842	1,070 JZ	299	45.0	1,410 J
SB-19-12	04/11/08	12	0.0292 U	0.0486 U	0.0486 U	0.0972 U	NA	4.86 U	11.5 U	28.6 U	22.5 UU
SB-20-9.5	04/14/08	9.5	0.0323 U	0.0538 U	0.0538 U	0.108 U	NA	5.38 U	11.8 U	29.5 U	23.3 UU
SB-21-10.5	04/14/08	10.5	0.0348 U	0.0581 U	0.0581 U	0.116 U	NA	5.81 U	12.3 U	30.6 U	24.4 UU
SB-22-10	04/11/08	10	0.0371 U [0.0371 U]	0.0618 U [0.0619 U]	0.0618 U [0.0619 U]	0.124 U [0.124 U]	NA [NA]	6.18 U [6.19 U]	12.8 U [12.3 U]	32.1 U [30.6 U]	25.5 UU [24.5 UU]
SB-23-11	04/11/08	11	0.0357 U	0.0595 U	0.0595 U	0.119 U	NA	5.95 U	12.2 U	30.5 U	24.3 UU
SB-24-10	04/11/08	10	0.0398 U	0.0663 U	0.0663 U	0.133 U	NA	6.63 U	12.9 U	32.3 U	25.9 UU
SB-25-11	04/11/08	11	0.0359 U	0.0598 U	0.0598 U	0.120 U	NA	5.98 U	12.0 U	30.0 U	24.0 UU
SB-26-10.5	04/14/08	10.5	0.0339 U	0.0565 U	0.0565 U	0.113 U	NA	5.65 U	11.6 U	29.1 U	23.2 UU
SB-27-10	04/14/08	10	0.200	0.0537 U	0.0537 U	0.107 U	0.00896	13.8 JZ	279	29.2 U	307 J
SB-28-9	04/11/08	9	0.0313 U	0.0522 U	0.0522 U	0.104 U	0.00838 UU	6.59	11.9	27.7 U	32.3
SB-29-9	04/08/08	9	0.0708	0.0566 U	0.0566 U	0.113 U	NA	10.7	11.4 U	28.4 U	30.6
SB-30-9.5	04/10/08	9.5	0.0343 U	0.0572 U	0.0572 U	0.114 U	NA	5.72 U	11.6 U	29.1 U	23.2 UU
SB-31-9.5	04/10/08	9.5	0.0420 U	0.0699 U	0.0699 U	0.140 U	NA	6.99 U	12.9 U	32.4 U	26.1 UU
SB-32-9.5	04/10/08	9.5	0.0541 U [0.0538 U]	0.0902 U [0.0897 U]	0.0902 U [0.0897 U]	0.180 U [0.179 U]	NA [NA]	9.02 U [8.97 U]	14.4 U [14.4 U]	36.0 U [36.0 U]	29.7 UU [29.7 UU]
SB-33-11	04/10/08	11	0.0471 U	0.0786 U	0.0786 U	0.157 U	NA	7.86 U	13.2 U	32.9 U	27.0 UU
SB-34-11	04/10/08	11	0.0344 U	0.0574 U	0.0574 U	0.115 U	NA	5.74 U	11.8 U	29.5 U	23.5 UU
SB-35-9	04/10/08	9	0.0442 U	0.0736 U	0.0736 U	0.147 U	NA	7.36 U	12.7 U	31.7 U	25.9 UU
SB-36-12	04/10/08	12	0.0252 U	0.0420 U	0.0420 U	0.0839 U	NA	4.20 U	10.9 U	27.2 U	21.2 UU

TABLE 8
Confirmation Boring Analytical Results
Unocal Edmonds Bulk Fuel Terminal Lower Yard
Phase I Remedial Implementation As-built Report
11720 Unoco Road
Edmonds, Washington

Sample ID	Date Sampled	Sample Depth (feet bgs)	BTEX (mg/kg)				Total cPAHs Adjusted for Toxicity (mg/kg)	Gasoline (mg/kg)	Diesel (mg/kg)	Heavy Oil (Lube) (mg/kg)	Total TPH (mg/kg)
			B	T	E	X					
			REL = 18 mg/kg				CUL = 0.14 mg/kg			REL = 2,975	
SB-37-9	04/08/08	9	0.224 [0.225]	0.0566 U [0.0647 U]	0.0566 U [0.0647 U]	0.113 U [0.129 U]	NA [NA]	5.66 U [6.47 U]	12.0 U [12.8 U]	29.9 U [31.9 U]	23.8 UU [25.6 UU]
SB-38-8.5	04/08/08	8.5	0.0749	0.0634 U	0.0634 U	0.127 U	NA	6.34 U	12.0 U	29.9 U	24.1 UU
SB-38-10	04/08/08	10	0.108	0.0585 U	0.0585 U	0.117 U	0.00929 UU	5.85 U	12.3 U	30.8 U	24.5 UU
SB-39-14	04/10/08	14	0.0285 U	0.0475 U	0.0475 U	0.0951 U	NA	4.75 U	11.3 U	28.4 U	22.2 UU
SB-40-11	04/10/08	11	0.0365 U	0.0609 U	0.0609 U	0.122 U	NA	6.09 U	12.1 U	30.1 U	24.1 UU
SB-41-10	04/10/08	10	0.0346 U	0.0576 U	0.0576 U	0.115 U	NA	5.76 U	11.8 U	29.6 U	23.6 UU
SB-42-10	04/09/08	10	0.0464 U [0.0821]	0.0774 U [0.0822 U]	0.166 [0.152]	0.327 [0.231]	NA [NA]	7.74 U [8.22 U]	14.1 U [14.8 U]	35.2 U [37.1 U]	28.5 UU [30.1 UU]
SB-43-11.5	04/09/08	11.5	0.0420 U	0.0699 U	0.0699 U	0.140 U	NA	6.99 U	13.3 U	33.3 U	26.8 UU
SB-44-11	04/09/08	11	0.205	0.0548 U	0.0548 U	0.110 U	NA	5.48 U	11.8 U	29.4 U	23.3 UU
SB-45-10	04/08/08	10	0.206	0.0591 U	0.0591 U	0.118 U	NA	5.91 U	11.4 U	28.4 U	22.9 UU
SB-46-6	04/08/08	6	0.0323 U	0.0538 U	0.0538 U	0.108 U	NA	5.38 U	11.5 U	28.8 U	22.8 UU
SB-46-10.5	04/08/08	10.5	0.0311 U	0.0518 U	0.0518 U	0.104 U	NA	5.18 U	11.4 U	28.5 U	22.5 UU
SB-47-10	04/09/08	10	0.0437 U	0.0729 U	0.0729 U	0.146 U	NA	7.29 U	12.9 U	32.2 U	26.2 UU
SB-48-11.5	04/09/08	11.5	0.0459 U	0.0765 U	0.0765 U	0.153 U	NA	7.65 U	13.6 U	34.1 U	27.7 UU
SB-49-10.5	04/09/08	10.5	0.0333 U	0.0555 U	0.0555 U	0.111 U	NA	5.55 U	11.8 U	29.4 U	23.4 UU
SB-50-10.5	04/09/08	10.5	0.0350 U	0.0583 U	0.0583 U	0.117 U	NA	5.83 U	12.1 U	30.2 U	24.1 UU
SB-51-9.5	04/08/08	9.5	0.0350 U	0.0583 U	0.0583 U	0.117 U	NA	5.83 U	12.1 U	30.3 U	24.1 UU
SB-52-9.5	04/08/08	9.5	0.0317 U	0.0528 U	0.0528 U	0.106 U	NA	5.28 U	11.4 U	28.5 U	22.6 UU
SB-53-10.5	04/09/08	10.5	0.0309 U	0.0515 U	0.0515 U	0.103 U	NA	14.8	10.8 U	27.1 U	33.8
SB-54-10.5	04/09/08	10.5	0.0373 U	0.0622 U	0.0622 U	0.124 U	NA	6.22 U	12.1 U	30.3 U	24.3 UU
SB-55-11.5	04/07/08	11.5	0.0606 U	0.101 U	0.101 U	0.202 U	NA	10.1 U	15.7 U	39.2 U	32.5 UU
SB-56-14.5	04/08/08	14.5	0.0337 U	0.0561 U	0.0561 U	0.112 U	NA	5.61 U	11.7 U	29.3 U	23.3 UU
SB-57-10.5	04/07/08	10.5	0.0307 U	0.0511 U	0.0511 U	0.102 U	NA	5.11 U	11.3 U	28.2 U	22.3 UU
SB-58-11.0	04/07/08	11	0.0359 U	0.0598 U	0.0598 U	0.120 U	NA	5.98 U	11.6 U	29.1 U	23.3 UU
SB-59-5.5	04/08/08	5.5	0.0311 U	0.0518 U	0.0518 U	0.104 U	NA	5.18 U	11.4 U	28.5 U	22.5 UU
SB-60-10.5	04/07/08	10.5	0.0825 [0.0864]	0.0741 U [0.0637 U]	0.0741 U [0.0637 U]	0.148 U [0.127 U]	NA [NA]	7.41 U [6.37 U]	12.3 U [21.7]	30.8 U [29.0 U]	25.3 UU [39.4]
SB-61-10.5	04/07/08	10.5	0.0511 U	0.0852 U	0.0852 U	0.170 U	NA	8.52 U	15.1 U	37.8 U	30.7 UU
SB-62-10.5	04/07/08	10.5	0.0607 U	0.101 U	0.101 U	0.202 U	NA	10.1 U	15.8 U	39.5 U	32.7 UU
SB-63-5.5	04/07/08	5.5	0.327 U	0.577	1.11	6.56	0.107	2,190 JZ	2,970 J	193 J	5,350 J
SB-63-6.0	04/07/08	6	0.157 J	0.194 J	2.16 J	8.43 J	NA	978 JZ	20.2 U	50.4 U	1,010 J
SB-64-2.5	04/07/08	2.5	0.656	2.75	1.72	7.15	0.108	1,540 JZ	5,810 J	362 J	7,710 J
SB-64-5.5	04/07/08	5.5	0.139 J	2.42 J	0.782 J	3.20 J	0.0452 UU	534 JZ	444	32.2	1,010 J
SB-64-7.0	04/07/08	7	0.325	0.157 U	0.157 U	0.730	NA	63.1	19.9 U	49.7 U	97.9

TABLE 8
Confirmation Boring Analytical Results
 Unocal Edmonds Bulk Fuel Terminal Lower Yard
 Phase I Remedial Implementation As-built Report
 11720 Unoco Road
 Edmonds, Washington

Notes:

BTEX analyzed by EPA Method 8021B.

cPAHs analyzed by EPA Method 8270 SIM.

Gasoline analyzed by method NWTPH-G.

Diesel and Heavy Oil (Lube) analyzed by method NWTPH-D Extended.

Total TPH calculated by summing the concentrations of gasoline, diesel and heavy oil. If one or more TPH constituents were reported as Non-Detect, half of the reporting limit value was added to the total.

cPAHs adjusted for toxicity according to WAC 173-340-708(8) and *Air Toxics Hot Spots Program Risk Assessment Guidelines, Part II Technical Support Document for Describing Available Cancer Potency Factors*.

Highlighted cells indicate concentration exceeds REL or CUL.

[] = Bracketed data indicate duplicate sample.

feet bgs = Feet below ground surface

BTEX = Benzene, toluene, ethylbenzene, and total xylenes

mg/kg = Milligrams per kilogram

cPAHs = Carcinogenic polyaromatic hydrocarbons

TPH = Total petroleum hydrocarbons

REL = Remediation level

CUL = Cleanup level

NA = Not analyzed

EPA = Environmental Protection Agency

Lab Qualifiers	Definition
J	Indicates an estimated value.
JZ	Detected hydrocarbons in the gasoline range appear to be due to overlap of diesel range hydrocarbons.
U	The compound was analyzed for but not detected. The associated value is the compound quantitation limit.
UJ	The compound was analyzed for but not detected. The associated value is the estimated compound quantitation limit.
UU	The constituents making up the total are all non-detects.



2007-2008 Final Phase II
Remedial Implementation As-Built
Report

TABLE 3
Excavation Soil Sample Analytical Results
 Unocal Edmonds Bulk Fuel Terminal Lower Yard
 Phase II Remedial Implementation As-built Report
 11720 Unoco Road
 Edmonds, Washington

Sample ID	Sample Depth (feet bgs)	Date Sampled	BTEX (mg/kg)				Total cPAHs Adjusted for Toxicity (mg/kg)	Diesel Range Organics (mg/kg)	Gasoline Range Organics (mg/kg)	Heavy Oil (Lube) (mg/kg)	Total TPH (mg/kg)
			B	T	E	X					
Site Soil Remediation Level (REL)/Cleanup Level (CUL) (mg/kg)			18	--	--	--	0.14	--	--	--	2,975
EX-AW-E-23-5	5	09/11/08	0.0404 U	0.0674 U	0.0674 U	0.135 U	0.278	596	109	410	1,120
EX-AW-E-23-5(2)	5	09/17/08	0.0363 U	0.0605 U	0.0605 U	0.121 U	NA	11.9 U	6.05 U	29.7 U	23.8 UU
EX-AW-E-24-10	10	09/11/08	0.0354 U	0.0590 U	0.0590 U	0.118 U	0.00891	28.1	5.90 U	29.0 U	45.6
EX-AW-E-24-NSW-5	5	09/11/08	0.0363 U	0.0605 U	0.0605 U	0.121 U	0.00892	357	30.0 JZ	134	521 J
EX-AW-E-25-10	10	09/11/08	0.0405 U	0.0675 U	0.0675 U	0.135 U	0.00982	102	6.75 U	32.8 U	122
EX-AW-E-25-ESW-5	5	09/11/08	0.0327 U [0.0339 U]	0.228 J [0.470 J]	0.0545 U [0.0564 U]	0.109 U [0.320 J]	0.00846 [0.00838]	18.4 [24.6]	75.2 JZ [171 JZ]	28.2 U [27.5 U]	108 J [209 J]
EX-AW-E-25-NSW-5	5	09/11/08	0.0373 U	0.0621 U	0.0621 U	0.124 U	0.00898	16.1	6.21 U	29.7 U	34.1
EX-AW-F-23-5	5	09/11/08	0.0359 U	0.0598 U	0.0598 U	0.120 U	0.00950	2,840	5.98 U	692	3,530
EX-AW-F-23-5(2)	5	09/12/08	0.0339 U	0.0565 U	0.0565 U	0.113 U	NA	11.6 U	5.65 U	29.1 U	23.2 UU
EX-AW-F-24-5	5	09/11/08	0.0345 U	0.0575 U	0.0575 U	0.115 U	NA	10.9 U	12.0	27.3 U	31.1
EX-AW-F-25-5	5	09/11/08	0.0277 U	0.0461 U	0.0461 U	0.0923 U	0.0181	58.1	6.68 JZ	71.8	137 J
EX-AW-F-25-ESW-5	5	09/11/08	0.0372 U	0.0620 U	0.0620 U	0.124 U	0.00846	62.6	6.20 U	27.9 U	79.7
EX-B1-C-46-4	4	08/08/08	0.355	1.06	0.294 U	3.20	0.228	2,920	260 JZ	911	4,090 J
EX-B1-C-46-4(2)	4	09/02/08	0.0302 U	0.0503 U	0.0503 U	0.101 U	0.0142	46.8 JY	5.03 U	92.7	142 J
EX-B1-C-47-4	4	08/08/08	0.0309 U	0.0679	0.0515 U	0.166	0.0414 UU	236	51.8 JZ	123	411 J
EX-B1-D-43-4	4	08/19/08	4.39	32.3	22.5	117	NA	11.6 U	2,000 J	29.0 U	2,020 J
EX-B1-D-44-12	12	08/18/08	0.121 U	0.202 U	0.202 U	0.404 U	0.0369 UU	25.6	20.2 U	60.3 U	65.9
EX-B1-D-44-NSW-4	4	08/18/08	1.23	2.68	0.470 U	9.81	0.554	9,620 J	678 JZ	3,350 J	13,600 J
EX-B1-D-44-NSW-4(2)	4	09/02/08	0.0508	0.107	0.0452 U	0.0903 U	0.0188	101	32.6	153	287
EX-B1-D-45-12	12	08/14/08	0.224 [0.0598 U]	0.956 J [0.0996 UJ]	1.41 J [0.0996 UJ]	4.87 J [0.199 UJ]	NA [NA]	14.6 U [15.4 U]	76.1 JZ [9.96 UJ]	36.4 U [38.5 U]	102 J [31.9 UU]
EX-B1-D-45-NSW-4	4	09/02/08	0.0316 U	0.0526 U	0.0526 U	0.105 U	0.0152	28.8 JY	5.26 U	69.0	100 J
EX-B1-D-46-12	12	08/11/08	0.113 U	0.189 U	0.189 U	0.378 U	0.0431	69.6 JY	18.9 U	158	237 J
EX-B1-D-47-4	4	08/08/08	0.0349 U	0.0582 U	0.0582 U	0.116 U	0.123	135	36.6 JZ	105	277 J
EX-B1-E-41-8	8	08/27/08	0.0325 U	0.0542 U	0.0542 U	0.108 U	0.0205	173	9.58	153	336
EX-B1-E-41-NSW-4	4	08/27/08	0.0314 U	0.0524 U	0.0524 U	0.105 U	NA	10.6 U	7.74	26.6 U	26.3
EX-B1-E-42-8	8	08/27/08	0.0327 U	0.0544 U	0.0544 U	0.109 U	0.0172	130	13.0	122	265
EX-B1-E-42-NSW-4	4	08/27/08	0.156	0.283	2.54	5.88	0.0714	76.8	223	83.1	383
EX-B1-E-43-12	12	08/21/08	0.259 U	0.431 U	0.431 U	0.863 U	NA	40.8 U	43.1 U	102 U	93.0 UU

TABLE 3
Excavation Soil Sample Analytical Results
 Unocal Edmonds Bulk Fuel Terminal Lower Yard
 Phase II Remedial Implementation As-built Report
 11720 Unoco Road
 Edmonds, Washington

Sample ID	Sample Depth (feet bgs)	Date Sampled	BTEX (mg/kg)				Total cPAHs Adjusted for Toxicity (mg/kg)	Diesel Range Organics (mg/kg)	Gasoline Range Organics (mg/kg)	Heavy Oil (Lube) (mg/kg)	Total TPH (mg/kg)
			B	T	E	X					
Site Soil Remediation Level (REL)/Cleanup Level (CUL) (mg/kg)			18	--	--	--	0.14	--	--	--	2,975
EX-B1-E-44-12	12	08/19/08	0.143 U	0.239 U	0.239 U	0.477 U	NA	28.0 U	23.9 U	69.9 U	60.9 UU
EX-B1-E-45-12	12	08/14/08	0.106 U	0.177 U	0.177 U	0.354 U	NA	19.8 U	17.7 U	49.6 U	43.6 UU
EX-B1-E-46-12	12	08/13/08	0.133 U	0.221 U	0.221 U	0.442 U	NA	23.0 U	22.1 U	57.6 U	51.4 UU
EX-B1-E-47-4	4	08/08/08	0.0336 U	0.147	0.0561 U	0.116	0.0172	21.1	5.61 U	26.9 U	37.4
EX-B1-E-47-SSW-4	4	08/08/08	0.351 U	0.586 U	0.743	4.44	0.756	11,400 J	493 JZ	3,820 J	15,700 J
EX-B1-E-47-SSW-4(2)	4	09/02/08	0.0280 U	0.0466 U	0.0466 U	0.0932 U	NA	10.8 U	4.66 U	27.0 U	21.2 UU
EX-B1-F-42-8	8	08/27/08	0.0332 U	0.0553 U	0.0553 U	0.111 U	0.0165	144	12.4	114	270
EX-B1-F-42-SSW-4	4	08/27/08	0.0327 U [0.0306 U]	0.0546 U [0.0511 U]	0.0546 U [0.0511 U]	0.109 U [0.102 U]	NA [NA]	10.7 U [10.6 U]	5.46 U [5.11 U]	26.8 U [26.6 U]	21.5 UU [21.2 UU]
EX-B1-F-43-4	4	08/21/08	0.0288 U	0.0481 U	0.0481 U	0.0961 U	0.0184	231	35.6 JZ	275	542 J
EX-B1-F-44-4	4	08/18/08	0.0298 U	0.0497 U	0.0497 U	0.0994 U	0.212	58.3	4.97 U	60.2	121
EX-B1-F-45-10	10	08/15/08	0.0671 U	0.112 U	0.112 U	0.224 U	NA	16.8 U	11.2 U	41.9 U	35.0 UU
EX-B1-F-45-SSW-4	4	08/18/08	0.0296 U	0.0493 U	0.0493 U	0.0986 U	0.0719	95.5	21.4 JZ	115	232 J
EX-B1-F-46-4	4	08/08/08	4.81	9.05	4.52	48.6	1.14	8,430 J	1,650 JZ	2,500 J	12,600 J
EX-B1-F-47-4(2)	4	09/02/08	0.0291 U	0.0486 U	0.0486 U	0.0971 U	NA	10.9 U	4.86 U	27.2 U	21.5 UU
EX-B7-B3-4	4	08/01/08	0.0377 U	0.0628 U	0.0628 U	0.126 U	0.0411	1,990	6.28 U	2,060	4,050
EX-B7-B4-4	4	08/01/08	0.366 U [0.0548 U]	0.610 U [0.0913 U]	0.610 U [0.0913 U]	1.22 U [0.183 U]	0.0488 [0.0517]	1,120 [960]	61.0 U [9.13 U]	629 [544]	1,780 [1,510]
EX-B7-B-4-5	5	09/10/08	0.0383 U	0.0638 U	0.0638 U	0.128 U	0.00944 UU	64.2	20.9	30.7 U	100
EX-B8-H-3-10	10	09/10/08	0.0385 U	0.0642 U	0.0642 U	0.128 U	NA	12.2 U	6.42 U	30.5 U	24.6 UU
EX-B8-H-3-NSW-5	5	09/10/08	0.0322 U	0.0537 U	0.0537 U	0.107 U	0.0266	10.9 U	5.37 U	31.2	39.3
EX-B8-H-3-WSW-5	5	09/10/08	0.0427 U	0.0712 U	0.0712 U	0.142 U	0.0439	58.0 JY	7.12 U	342	404 J
EX-B8-I-3-10	10	09/10/08	0.0412 U	0.0686 U	0.0686 U	0.137 U	NA	12.4 U	6.86 U	31.0 U	25.1 UU
EX-B8-I-3-WSW-5	5	09/10/08	0.0833 U	0.139 U	0.139 U	0.278 U	0.0728	2,740	15.0	2,590	5,350
EX-B8-I-3-WSW-5(2)	5	09/11/08	0.0525 U	0.0875 U	0.0875 U	0.175 U	0.0589	352	8.75 U	354	710
EX-B8-J-3-10	10	09/10/08	0.0369 U	0.0616 U	0.0616 U	0.123 U	NA	11.8 U	6.16 U	29.5 U	23.7 UU
EX-B8-J-3-SSW-5	5	09/10/08	0.0302 U [0.0338 U]	0.0504 U [0.0564 U]	0.0504 U [0.0564 U]	0.101 U [0.113 U]	0.00793 UU [0.00793 UU]	51.5 [335 JY]	9.14 [5.64 U]	41.1 [315]	102 [653 J]
EX-B8-J-3-WSW-5	5	09/10/08	0.0302 U	0.0503 U	0.0503 U	0.101 U	0.00800 UU	270 JY	5.03 U	278	551 J
EX-B9-N-3-5	5	09/09/08	0.0331 U	0.0551 U	0.0551 U	0.110 U	NA	10.8 U	5.51 U	26.9 U	21.6 UU
EX-B9-O-3-10	10	09/09/08	0.0353 U	0.0588 U	0.0588 U	0.118 U	NA	11.7 U	9.57	29.3 U	30.1
EX-B9-O-3-WSW-5	5	09/09/08	0.0322 U	0.0537 U	0.0537 U	0.107 U	NA	10.5 U	5.37 U	26.2 U	21.0 UU
EX-B9-P-3-10	10	09/09/08	0.0360 U	0.0600 U	0.0600 U	0.120 U	NA	12.0 U	11.4	29.9 U	32.4
EX-B9-P-3-SSW-5	5	09/09/08	0.0320 U	0.0533 U	0.0533 U	0.107 U	NA	10.6 U	5.33 U	26.4 U	21.2 UU

TABLE 3
Excavation Soil Sample Analytical Results
Unocal Edmonds Bulk Fuel Terminal Lower Yard
Phase II Remedial Implementation As-built Report
11720 Unoco Road
Edmonds, Washington

Sample ID	Sample Depth (feet bgs)	Date Sampled	BTEX (mg/kg)				Total cPAHs Adjusted for Toxicity (mg/kg)	Diesel Range Organics (mg/kg)	Gasoline Range Organics (mg/kg)	Heavy Oil (Lube) (mg/kg)	Total TPH (mg/kg)
			B	T	E	X					
Site Soil Remediation Level (REL)/Cleanup Level (CUL) (mg/kg)			18	--	--	--	0.14	--	--	--	2,975
EX-B9-P-3-WSW-5	5	09/09/08	0.0327 U	0.0545 U	0.0545 U	0.109 U	NA	10.3 U	5.45 U	25.9 U	20.8 UU
ISP-E-17-2	2	09/17/08	0.0310 U	0.0516 U	0.0516 U	0.103 U	NA	10.4 U	5.16 U	26.1 U	20.8 UU
ISP-E-18-2	2	09/17/08	0.0312 U	0.0519 U	0.0519 U	0.104 U	0.0248	15.2	5.19 U	27.9 U	31.7
ISP-E-19-2	2	09/22/08	0.0337 U	0.0562 U	0.0562 U	0.112 U	0.00868 UU	51.3 J	5.62 U	42.8	96.9 J
ISP-E-20-2	2	09/22/08	0.0333 U	0.0555 U	0.0555 U	0.111 U	0.0212	105	7.17 JZ	67.4	180 J
ISP-E-21-2	2	09/22/08	0.0318 U	0.0530 U	0.0530 U	0.113	0.00850	16.7	25.0 JZ	27.7 U	55.6 J
ISP-F-17-2	2	09/17/08	0.0319 U	0.0532 U	0.0532 U	0.106 U	NA	10.4 U	5.32 U	26.0 U	20.9 UU
ISP-F-18-2	2	09/17/08	0.0267 U	0.0445 U	0.0445 U	0.0890 U	0.0170	29.0	4.45 U	32.9	64.1
ISP-F-19-2	2	09/22/08	0.0329 U	0.0549 U	0.0549 U	0.110 U	0.0523	14.3	5.49 U	27.5 U	30.8
ISP-F-20-2	2	09/22/08	0.0351 U	0.0585 U	0.0585 U	0.117 U	0.0498	11.6	5.85 U	27.1 U	28.1
ISP-F-21-2	2	09/22/08	0.0344 U	0.0574 U	0.0574 U	0.115 U	NA	11.0 U	5.74 U	27.4 U	22.1 UU
ISP-G-17-2	2	09/17/08	0.0314 U	0.0524 U	0.0524 U	0.105 U	NA	10.4 U	5.24 U	26.1 U	20.9 UU
ISP-G-18-2	2	09/17/08	0.0314 U	0.0523 U	0.0523 U	0.105 U	NA	10.6 U	5.23 U	26.4 U	21.1 UU
ISP-G-19-2	2	09/22/08	0.0305 U [0.0301 U]	0.0508 U [0.0502 U]	0.0508 U [0.0502 U]	0.102 U [0.100 U]	0.306 [0.0187]	38.9 [47.5]	5.08 U [5.02 U]	27.5 U [27.5 U]	55.2 [63.8]
ISP-G-19-2(2)	2	09/25/08	0.0344 U	0.0573 U	0.0573 U	0.115 U	0.0161	75.5	5.73 U	57.1	135
ISP-G-20-2	2	09/22/08	0.0328 U	0.0546 U	0.0546 U	0.109 U	0.00823 UU	11.4	5.46 U	27.1 U	27.7
ISP-G-21-2	2	09/22/08	0.0322 U	0.0536 U	0.0536 U	0.107 U	0.0335	74.1	9.03 JZ	35.0	118 J
EX-RRT-ZZ-2-4	4	08/01/08	0.0552 U	0.0920 U	0.0920 U	0.184 U	NA	15.2 U	20.3	38.0 U	46.9
EX-RRT-ZZ-2-ESW-3	3	08/01/08	0.0800 U	0.133 U	0.133 U	0.560 J	NA	18.2 U	46.4 J	45.4 U	78.2 J
RRT-YY-2-6	6	08/04/08	0.105 U	0.376 J	0.174 U	1.61 J	NA	20.8 U	39.9 J	52.0 U	76.3 J
RRT-YY-2-WSW-3	3	08/04/08	0.0397 U [0.0357 U]	0.0661 U [0.0595 U]	0.0661 U [0.0595 U]	0.132 U [0.119 U]	0.00808 UU [0.00808 UU]	27.1 JY [26.8 JY]	6.61 U [5.95 U]	32.9 [31.6]	63.3 J [61.4 J]
RRT-ZZ-2-NSW-3	3	08/04/08	0.0349 U	0.0581 U	0.0581 U	0.116 U	0.00853 UU	30.2 J	5.81 U	60.4	93.5 J
RRT-ZZ-3-NSW-3	3	08/04/08	0.0382 U	0.0637 U	0.0637 U	0.127 U	NA	11.8 U	6.37 U	29.4 U	23.8 UU

TABLE 3
Excavation Soil Sample Analytical Results
 Unocal Edmonds Bulk Fuel Terminal Lower Yard
 Phase II Remedial Implementation As-built Report
 11720 Unoco Road
 Edmonds, Washington

Notes:

BTEX analyzed by EPA Method 8021B.

cPAHs analyzed by EPA Method 8270 SIM.

Gasoline analyzed by method NWTPH-G.

Diesel and Heavy Oil (Lube) analyzed by method NWTPH-D Extended.

Total TPH calculated by summing the concentrations of gasoline, diesel and heavy oil. If one or more TPH constituents were reported as Non-Detect, half of the reporting limit value was added to the total.

cPAHs adjusted for toxicity according to WAC 173-340-708(8) and *Air Toxics Hot Spots Program Risk Assessment Guidelines, Part II Technical Support Document for Describing Available Cancer Potency Factors*. Office of Environmental Health Hazard Assessment, California EPA, May 2005. If one or more adjusted cPAH constituents were reported as Non-Detect, half of the reporting limit was used in calculations.

Highlighted cells indicate concentration exceeds REL or CUL.

NA = Indicates analysis not conducted.

[] = Bracketed data indicate duplicate sample.

BTEX = Benzene, toluene, ethylbenzene, and total xylenes

EPA = Environmental Protection Agency

mg/kg = Milligrams per kilogram

cPAHs = Carcinogenic polynuclear aromatic hydrocarbons

REL = Remediation level

CUL = Cleanup level

TPH = Total petroleum hydrocarbons

bgs = below ground surface

Lab Qualifiers	Definition
J	Indicates an estimated value.
JY	Results in the diesel organics range are primarily due to overlap from a heavy oil range product.
JZ	Detected hydrocarbons in the gasoline range appear to be due to overlap of diesel range hydrocarbons.
Q4	The hydrocarbons present are a complex mixture of diesel range and heavy oil range organics.
U	The compound was analyzed for but not detected. The associated value is the compound quantitation limit.
UJ	The compound was analyzed for but not detected. The associated value is the estimated compound quantitation limit.
UU	The constituents making up the total are all non-detects.

TABLE 6
Monitoring Well Installation Soil Sample Analytical Results
 Unocal Edmonds Bulk Fuel Terminal Lower Yard
 Phase II Remedial Implementation As-built Report
 11720 Unoco Road
 Edmonds, Washington

Sample ID	Sample Depth (feet bgs)	Date Sampled	BTEX (mg/kg)				Total cPAHs Adjusted for Toxicity (mg/kg)	Diesel Range Organics (mg/kg)	Gasoline Range Organics (mg/kg)	Heavy Oil (Lube) (mg/kg)	Total TPH (mg/kg)
			B	T	E	X					
Site Soil Remediation Level (REL)/Cleanup Level (CUL) (mg/kg)			18	--	--	--	0.14	--	--	--	2,975
MW-129R-4.5	4.5	10/14/08	0.0303 U	0.0506 U	0.0506 U	0.101 U	0.0439	823	24.4 JZ	178	1,030 J
MW-129R-7.0	7	10/14/08	0.0446 U	0.0743 U	0.0743 U	0.149 U	0.0479 UU	2,690	7.43 U	313	3,010
MW-502-6.0	6	10/14/08	0.0337 U	0.0562 U	0.0562 U	0.112 U	NA	11.6 U	5.62 U	29.0 U	23.1 UU
MW-511-8.5	8.5	10/14/08	0.0378 U [0.0361 U]	0.0630 U [0.0601 U]	0.0630 U [0.0601 U]	0.126 U [0.120 U]	NA [NA]	11.7 U [11.5 U]	6.30 U [6.01 U]	29.2 U [28.8 U]	23.6 UU [23.2 UU]
MW-510-6.5	6.5	10/08/08	0.0462 U	0.0770 U	0.0770 U	0.154 U	0.0200 UU	80.5	7.70 U	33.0 U	101
MW-510-12.5	12.5	10/08/08	0.0345 U	0.0574 U	0.0574 U	0.115 U	NA	11.9 U	5.74 U	29.6 U	23.6 UU

Notes:

BTEX analyzed by EPA Method 8021B.

cPAHs analyzed by EPA Method 8270 SIM.

Gasoline analyzed by method NWTPH-G.

Diesel and Heavy Oil (Lube) analyzed by method NWTPH-D Extended.

Total TPH calculated by summing the concentrations of gasoline, diesel and heavy oil. If one or more TPH constituents were reported as Non-Detect, half of the reporting limit value was added to the total.

cPAHs adjusted for toxicity according to WAC 173-340-708(B) and *Air Toxics Hot Spots Program Risk Assessment Guidelines, Part II Technical Support Document for Describing Available Cancer Potency Factors*.

Office of Environmental Health Hazard Assessment, California EPA, May 2005. If one or more adjusted cPAH constituents were reported as Non-Detect, half of the reporting limit was used in calculations.

Highlighted cells indicate concentration exceeds REL or CUL.

NA = Indicates analysis not conducted.

[] = Bracketed data indicate duplicate sample.

BTEX = Benzene, toluene, ethylbenzene, and total xylenes

EPA = Environmental Protection Agency

mg/kg = Milligrams per kilogram

cPAHs = Carcinogenic polynuclear aromatic hydrocarbons

REL = Remediation level

CUL = Cleanup level

TPH = Total petroleum hydrocarbons

Lab Qualifiers Definition

- J Indicates an estimated value.
- JZ Detected hydrocarbons in the gasoline range appear to be due to overlap of diesel range hydrocarbons.
- U The compound was analyzed for but not detected. The associated value is the compound quantitation limit.
- UU The constituents making up the total are all non-detects.



2008 Additional Site Investigation
and Groundwater Monitoring
Report

Table 1

Additional Site Investigation
 Soil Analytical Data
 Former Unocal Terminal
 11720 Unoco Road
 Edmonds, Washington

Sample ID	Sample Depth (feet bgs)	Date Sampled	BTEX ¹ (EPA Method 8021B) (mg/kg)				Total Adjusted cPAHs ² (EPA Method 8270 SIM) (mg/kg)	NWTPH-G (mg/kg) Gasoline	NWTPH-D Extended (mg/kg)		Total TPH ³ (mg/kg)
			B	T	E	X			Diesel	Heavy Oil (Lube)	
Site Soil Remediation Level (REL)/Cleanup Level (CUL) (mg/kg)			18	--	--	--	0.14	--	--	--	2,975
SB-65-6.5	6.5	06/26/08	35.8 J	47.2 J	3.79 J	4.35 J	1.01	3,820	9,450 J	3,660 J	16,900 J
SB-65-8.0	8	06/26/08	14.5	78.0	2.96 U	48.9	0.0928	2,290	1,910	186	4,390
SB-65-16.0	16	06/26/08	0.0588	0.241	0.0575 U	0.782	0.00883 UU	13.1	176	35.6	225
SB-65-20	20	06/26/08	0.259	1.13	0.0432 U	3.79	0.0161	59.2	136	28.6 U	210
SB-65-23	23	06/26/08	0.275	1.43	0.0677	4.66	0.0158	61.3	85.1	28.8 U	161
SB-66-6.0	6	06/26/08	0.0746	0.281	0.0598 U	2.92	0.209	467 JZ	9,790 J	1,640 J	11,900 J
SB-66-11.5	11.5	06/30/08	0.0381 U	0.0635 U	0.0635 U	0.127 U	0.00914 UU	6.35 U	15.0	30.4 U	33.4
SB-66-15	15	06/30/08	0.0331 U	0.0552 U	0.0552 U	0.110 U	NA	5.52 U	11.6 U	29.1 U	23.1 UU
SB-67-5.5	5.5	06/24/08	0.0398 U	0.0663 U	0.0663 U	0.133 U	NA	6.63 U	11.9 U	29.7 U	24.1 UU
SB-68-4.0	4	06/24/08	0.334 U	29.7	0.653	88.7	0.165	4,090	1,240	141	5,470
SB-68-5.5	5.5	06/24/08	0.350 U	32.9 J	0.583 U	166	0.101	3,960	633	143 U	4,660
SB-68-13.5	13.5	06/25/08	0.0367 U	0.403	0.0612 U	2.65	0.00898 UU	73.7	11.9	29.7 U	100
SB-68-15.0	15	06/25/08	0.0364 U	0.0606 U	0.0606 U	0.121 U	NA	6.06 U	12.0 U	30.1 U	24.1 UU
SB-69-6.0	6	06/26/08	0.149 J	4.34 J	1.07 J	48.3	0.236 UU	1,770	1,870	157 U	3,720
SB-69-12.0	12	06/26/08	0.0385 U	0.0642 U	0.0642 U	0.128 U	NA	6.42 U	11.9 U	29.7 U	24.0 UU
SB-69-15.0	15	06/26/08	0.0393 U [0.0384 U]	0.0654 U [0.0639 U]	0.0654 U [0.0639 U]	0.131 U [0.128 U]	NA	6.54 U [6.39 U]	11.9 U [14.4]	29.7 U [30.1 U]	24.1 UU [32.6]
SB-70-6.0	6	06/24/08	0.0371 U	0.0618 U	0.0618 U	0.124 U	NA	6.18 U	10.9 U	27.2 U	22.1 UU
SB-70-7.0	7	06/25/08	0.0369 U	0.0616 U	0.0616 U	0.123 U	NA	6.16 U	11.5 U	28.8 U	23.2 UU
SB-70-12.5	12.5	06/25/08	0.0366 U	0.0611 U	0.0611 U	0.122 U	NA	6.11 U	11.6 U	29.1 U	23.4 UU
SB-70-20.5	20.5	06/25/08	0.0340 U	0.0567 U	0.0567 U	0.113 U	NA	5.67 U	11.8 U	29.4 U	23.4 UU
SB-71-8.0	8	06/25/08	0.0368 U	0.0614 U	0.0614 U	0.123 U	NA	6.14 U	11.7 U	29.3 U	23.6 UU
SB-71-15.5	15.5	06/25/08	0.0363 U	0.0605 U	0.0605 U	0.121 U	0.00876 UU	6.05 U	11.6 U	42.1	50.9
SB-71-24.0	24	06/25/08	0.0366 U	0.0610 U	0.0610 U	0.122 U	NA	6.10 U	11.8 U	29.4 U	23.7 UU
SB-72-6.5	6.5	06/25/08	0.0371 U	0.0619 U	0.0619 U	0.124 U	NA	6.19 U	11.7 U	29.3 U	23.6 UU
SB-72-15.5	15.5	06/25/08	0.0348 U	0.0581 U	0.0581 U	0.116 U	NA	5.81 U	12.1 U	30.1 U	24.0 UU
SB-72-24.5	24.5	06/25/08	0.0400 U [0.0421 U]	0.0667 U [0.0701 U]	0.0667 U [0.0701 U]	0.133 U [0.140 U]	NA	6.67 U [7.01 U]	12.5 U [12.6 U]	31.2 U [31.5 U]	25.2 UU [25.6 UU]
SB-73-6.0	6	06/26/08	0.0445 U	0.0741 U	0.0741 U	0.148 U	NA	7.41 U	13.0 U	32.6 U	26.5 UU
SB-73-15.0	15	06/26/08	0.0369 U	0.0615 U	0.0615 U	0.123 U	NA	6.15 U	12.0 U	30.1 U	24.1 UU
SB-74-6.0	6	06/26/08	0.0375 U	0.0625 U	0.0625 U	0.125 U	NA	6.25 U	12.2 U	30.4 U	24.4 UU
SB-74-15	15	06/26/08	0.0380 U	0.0634 U	0.0634 U	0.127 U	NA	6.34 U	12.2 U	30.4 U	24.5 UU
SB-75-6.0	6	06/26/08	0.0406 U	0.0677 U	0.0677 U	0.135 U	NA	6.77 U	12.2 U	30.5 U	24.7 UU
SB-75-15.0	15	06/26/08	0.0398 U	0.0663 U	0.0663 U	0.133 U	NA	6.63 U	12.3 U	30.8 U	24.9 UU

Table 1

Additional Site Investigation
 Soil Analytical Data
 Former Unocal Terminal
 11720 Unoco Road
 Edmonds, Washington

Sample ID	Sample Depth (feet bgs)	Date Sampled	BTEX ¹ (EPA Method 8021B) (mg/kg)				Total Adjusted cPAHs ² (EPA Method 8270 SIM) (mg/kg)	NWTPH-G (mg/kg) Gasoline	NWTPH-D Extended (mg/kg)		Total TPH ³ (mg/kg)
			B	T	E	X			Diesel	Heavy Oil (Lube)	
Site Soil Remediation Level (REL)/Cleanup Level (CUL) (mg/kg)			18	--	--	--	0.14	--	--	--	2,975
SB-76-4.5	4.5	06/30/08	0.0389 U	0.0648 U	0.316	0.130 U	NA	9.14	11.4 U	28.5 U	29.1
SB-76-9	9	06/30/08	0.0436 U	0.0727 U	0.0727 U	0.145 U	0.198	7.66 JZ	14,500 J	2,550 J	17,100 J
SB-76-10.5	10.5	06/30/08	0.0501 U	0.0835 U	0.0835 U	0.167 U	0.190	40.1 JZ	2,090 J	409 J	2,540 J
SB-76-14	14	06/30/08	0.0288 U [0.0355 U]	0.0480 U [0.0591 U]	0.0480 U [0.0591 U]	0.0959 U [0.118 U]	NA	4.80 U [5.91 U]	12.0 U [11.9 U]	30.0 U [29.8 U]	23.4 UU [23.8 UU]
SB-77-6	6	06/30/08	0.0392 U	0.0653 U	0.0653 U	0.131 U	NA	6.53 U	12.0 U	29.9 U	24.2 UU
SB-77-9.5	9.5	06/30/08	0.0439 U	0.0731 U	0.0731 U	0.146 U	0.214	7.31 U	7,120 J	757 J	7,880 J
SB-77-14	14	06/30/08	0.0336 U	0.0561 U	0.0561 U	0.112 U	NA	5.61 U	11.8 U	29.5 U	23.5 UU
SB-78-5.5	5.5	06/30/08	6.57 J	9.74 J	42.4 J	49.6 J	0.0183	693	257	356	1,310
SB-78-8.5	8.5	06/30/08	0.0351 U	0.0585 U	0.0585 U	0.117 U	NA	5.85 U	11.4 U	28.4 U	22.8 UU
SB-78-10	10	06/30/08	0.0325 U	0.0542 U	0.0542 U	0.108 U	NA	15.1 JZ	11.4 U	28.6 U	35.1 J
SB-78-12.5	12.5	06/30/08	0.0353 U	0.0589 U	0.0589 U	0.118 U	NA	5.89 U	12.2 U	30.6 U	24.3 UU
SB-79-5	5	06/30/08	0.0344 U	0.0573 U	0.0573 U	0.115 U	NA	5.73 U	11.0 U	27.5 U	22.1 UU
SB-79-8.5	8.5	06/30/08	0.0348 U	0.0581 U	0.0581 U	0.116 U	0.276	32.5 JZ	2,960 J	964 J	3,960 J
SB-79-10	10	06/30/08	0.0468 U	0.0779 U	0.0779 U	0.156 U	0.0198	19.7 JZ	137	37.0	194 J
SB-79-11.5	11.5	06/30/08	0.0550 U	0.0916 U	0.0916 U	0.183 U	NA	9.16 U	13.1 U	32.7 U	27.5 UU
SB-80-7.5	7.5	06/26/08	0.0392 U	0.0654 U	0.0654 U	0.131 U	0.693	24.5 JZ	1,870	2,770	4,660 J
SB-80-11.0	11	06/26/08	0.0518 U	0.0864 U	0.0864 U	0.173 U	NA	8.64 U	13.6 U	34.0 U	28.1 UU
SB-81-5	5	06/30/08	0.0301 U	0.0501 U	0.0501 U	0.100 U	0.0896	21.1 JZ	34.4	49.4	105 J
SB-81-9.5	9.5	06/30/08	0.0414 U	0.0691 U	0.0691 U	0.138 U	NA	6.91 U	12.6 U	31.4 U	25.5 UU
SB-81-15.5	15.5	06/30/08	0.0333 U	0.0556 U	0.0556 U	0.111 U	NA	5.56 U	11.6 U	29.0 U	23.1 UU
SB-82-7	7	07/01/08	0.0349 U	0.0581 U	0.0581 U	0.116 U	NA	5.81 U	11.9 U	29.7 U	23.7 UU
SB-82-9	9	07/01/08	0.0455 U	0.0758 U	0.0758 U	0.152 U	NA	7.58 U	13.6 U	33.9 U	27.5 UU
SB-83-7	7	07/01/08	0.0333 U	0.0555 U	0.0555 U	0.111 U	0.00891	5.55 U	16.8	29.6 U	34.4
SB-83-8.5	8.5	07/01/08	0.0502 U	0.0837 U	0.0837 U	0.167 U	0.0108	8.37 U	18.7	35.6 U	40.7
SB-84-6	6	07/01/08	0.0610 U	0.102 U	0.102 U	0.203 U	0.0119	10.2 U	20.7	43.3	69.1
SB-84-8	8	07/01/08	0.0745 U	0.124 U	0.124 U	0.248 U	NA	12.4 U	17.6 U	44.0 U	37.0 UU
SB-85-5.5	5.5	07/02/08	0.0357 U	0.0596 U	0.0596 U	0.119 U	0.0225	5.96 U	75.4	28.2 U	92.5
SB-85-7.5	7.5	07/02/08	0.114 U	0.218 J	0.189 U	1.09 J	NA	177 J	21.2 U	52.9 U	214 J
SB-86-4.5	4.5	07/02/08	0.0324 U	0.0540 U	0.0540 U	0.108 U	0.0182	5.40 U	31.1 JY	77.9	112 J
SB-86-6.5	6.5	07/02/08	0.0513 U	0.0856 U	0.0856 U	0.171 U	NA	8.56 U	14.2 U	35.4 U	29.1 UU
SB-87-6.0	6	07/25/08	0.0600	0.0825	0.0464 U	0.153	0.0535	74.2 JZ	79.8	88.6	243 J
SB-87-14.0	14	07/25/08	0.0477	0.0686 U	0.0686 U	0.137 U	NA	6.86 U	12.2 U	30.4 U	24.7 UU
SB-88-8.0	8	07/25/08	0.0145 U	0.0242 U	0.0242 U	0.0484 U	0.0167	2.59	35.9	98.5	137

Table 1

Additional Site Investigation
 Soil Analytical Data
 Former Unocal Terminal
 11720 Unoco Road
 Edmonds, Washington

Sample ID	Sample Depth (feet bgs)	Date Sampled	BTEX ¹ (EPA Method 8021B) (mg/kg)				Total Adjusted cPAHs ² (EPA Method 8270 SIM) (mg/kg)	NWTPH-G (mg/kg)	NWTPH-D Extended (mg/kg)		Total TPH ³ (mg/kg)
			B	T	E	X		Gasoline	Diesel	Heavy Oil (Lube)	
Site Soil Remediation Level (REL)/Cleanup Level (CUL) (mg/kg)			18	--	--	--	0.14	--	--	--	2,975
Notes											
Shaded data indicates concentrations greater than the applicable site Remedial Action Levels. (mg/kg)= milligram per kilogram (parts per million) bgs= below ground surface ¹ B= Benzene, T= Toluene, E= Ethylbenzene, X= Total Xylenes ² Carcinogenic Polynuclear Aromatic Hydrocarbons (cPAHs). cPAHs adjusted for toxicity according to WAC 173-340-708(8) and Air Toxics Hot Spots Program Risk Assessment Guidelines, Part II Technical Support Document for Describing Available Cancer Potency Factors. Office of Environmental Health Hazard Assessment, California EPA. May 2005. If one or more adjusted cPAH constituents were reported as Non-Detect, half of the reporting limit was used in calculations. ³ Total TPH calculated by summing the concentrations of gasoline, diesel and heavy oil. If any TPH constituents were reported as Non-Detect, half of the reporting limit value was used. NA = Indicates analysis not conducted. [] = Bracketed data indicate duplicate sample.											
Lab Qualifiers Definition											
J Indicates an estimated value. JY Results in the diesel organics range are primarily due to overlap from a heavy oil range JZ Detected hydrocarbons in the gasoline range appear to be due to overlap of diesel range hydrocarbons U The compound was analyzed for but not detected. The associated value is the compound quantitation limit UU The constituents making up the total are all non-detects.											



2011 Final Site Investigation
Completion Report

TABLE 1
Tidal Study Results Summary
Former Unocal Terminal
11720 Unoco Road
Edmonds, Washington

Well ID	GWE (feet)		Depth (feet)		Salinity (PSU)			Amplitude (feet)	
	Max	Min	Max	Min	Max	Min	Avg	Max	Min
LM-2	6.68	6.50	5.34	5.16	12.32	8.94	11.07	--	--
MW-8R	6.42	5.77	4.60	3.95	0.22	0.18	0.19	0.31	0.02
MW-104	5.42	4.53	8.34	7.45	0.14	0.11	0.12	0.53	0.03
MW-122	-1.06	-1.39	8.40	8.07	0.39	0.38	0.38	0.33	0.02
MW-129R	7.28	6.76	6.99	6.47	0.69	0.63	0.67	0.37	0.03
MW-149R	6.10	4.59	5.92	4.41	0.34	0.23	0.29	1.15	0.07
MW-500	13.35	12.63	8.46	7.74	0.44	0.30	0.37	--	--
MW-501	12.98	12.60	9.74	9.36	0.17	0.15	0.17	--	--
MW-502	8.92	8.66	8.02	7.76	0.17	0.14	0.17	--	--
MW-515	7.47	7.21	7.57	7.31	0.21	0.18	0.19	--	--
MW-518	6.98	6.19	4.88	4.09	0.32	0.27	0.30	0.56	0.02
Staff Gauge ID	GWE (feet)		Depth (feet)		Salinity (PSU)			Amplitude (feet)	
	Max	Min	Max	Min	Max	Min	Avg	Max	Min
D-1	8.20	5.95	2.53	0.28	27.76	0.22	10.72	1.96	0.02
D-2	8.13	5.63	2.11	-0.39	27.56	0.10	10.68	1.84	0.04
D-3	8.11	5.59	2.37	-0.15	27.96	0.00	9.73	2.12	0.02
D-5	8.76	4.81	2.65	-1.30	27.76	0.00	11.55	3.73	0.19
D-6	6.84	5.54	2.43	2.43	1.80	1.47	1.68	--	--
TB	5.56	3.06	3.36	0.86	30.08	0.31	12.91	2.22	0.04

Notes:

GWE = Groundwater Elevations in feet above mean sea level

PSU = Practical Salinity Units

TABLE 2
Well Construction Details Summary
 Unocal Edmonds Bulk Fuel Terminal Lower Yard
 11720 Unoco Road
 Edmonds, Washington

Well ID	Date Installed	Top of Casing (feet amsl) ^a	Well Diameter (inches)	Well Material	Pipe Schedule	Slotted Screen Size (inches)	Borehole Diameter (inches)	Top of Screen (feet bgs)	Bottom of Screen (feet bgs)	Well Depth (feet bgs)	Borehole Depth (feet bgs)	Top of Filter Pack (feet bgs)	Bottom of Filter Pack (feet bgs)	Depth to Bottom - 2008 (feet btoc) ^b
LM-2	4/18/1989	8.14	2	PVC	40	0.02	--	2.5	8	8	9.1	2	9	7.8
MW-8R	10/9/2008	13.82	2	PVC	40	0.01	8	3	13	13	13	2	13	13
MW-104	12/22/1992	14.08	2	PVC	40	0.02	10	5	15	15	16.5	7	15	18.2
MW-122	9/27/1995	15.54	2	PVC	40	0.01	--	30	40	40	41.5	27.66	41.5	42.65
MW-129R	10/14/2008	12.92	2	PVC	40	0.01	8	3	13	13	13.5	2	13.5	12.9
MW-149R	10/8/2008	12.18	2	PVC	40	0.01	8	3	13	13	13.5	2	13	13
MW-500	10/14/2008	16.64	2	PVC	40	0.01	8	3	13	13	13	2	13	12.75
MW-501	10/14/2008	15.24	2	PVC	40	0.01	8	3	13	13	13	2	13	13
MW-502	10/14/2008	13.00	2	PVC	40	0.01	8	3	13	13	13	2	13	13.1
MW-515	10/10/2008	11.60	2	PVC	40	0.01	8	3	13	13	13	2	13	12.7
MW-518	10/8/2008	14.60	2	PVC	40	0.01	8	3.5	13.5	13.5	13.5	2	13.5	13.5
MW-521	10/9/2008	12.18	2	PVC	40	0.01	8	3	13	13	13	2	13	12.7
MW-522	10/9/2008	13.82	2	PVC	40	0.01	8	3	13	13	13	2	13	12.7
MW-523	10/8/2008	13.53	2	PVC	40	0.01	8	3	13	13	13	2	13	12.7

Notes:

(a) Vertical Datum: N.A.V.D. 88

(b) Depth to bottom was gauged on October 20, 2008, following well development activities.

amsl = above mean sea level

-- = Data not available

bgs = below ground surface

btoc = below top of casing

TABLE 3
Hydraulic Conductivity Step Test Data Summary
 Unocal Edmonds Bulk Fuel Terminal Lower Yard
 11720 Unoco Road
 Edmonds, Washington

Well ID	Date	Pump Used	Initial DTW (feet)	Flow Rate (GPM)	Maximum Drawdown (feet)	Notes
MW-104	5/11/2011	2" Submersible Pump	7.90	0.50	0.45	Test terminated due to pump failure.
				1.0	1.37	
				1.5	2.80	
MW-129R	5/12/2011	2" Submersible Pump	5.35	0.50	5.84	Well pumped dry at 0.5 GPM.
				0.25	5.65	
MW-149R	5/11/2011	2" Submersible Pump	6.63	0.50	1.07	
				1.0	1.98	
				1.5	2.96	
MW-500	5/10/2011	Peristaltic Pump	3.81	0.10	1.30	Test terminated after 109 minutes. Stabilized drawdown not achieved.
	5/12/2011	2" Submersible Pump	3.80	0.19	5.55	
	0.50	7.61				
MW-518	5/11/2011	2" Submersible Pump	8.01	0.25	0.36	Test terminated after 60 minutes.
				1.0	1.39	
				1.5	1.90	
MW-8R	5/12/2011	2" Submersible Pump	8.03	0.25	0.11	Test terminated due to pump tubing failure.
				0.50	0.12	
				1.5	1.26	
	5/18/2011	2" Submersible Pump	7.50	2.0	0.17	
				4.0	0.46	
				5.0	0.59	
LM-2	5/11/2011	2" Submersible Pump	1.48	0.25	4.59	Well pumped dry.
	5/13/2011	Peristaltic Pump	1.47	0.10	1.80	
				0.15	2.18	
				0.18	3.43	

Notes:
 DTW: Depth to water
 btoc: below top of casing
 GPM: Gallons per minute

TABLE 4
Short Duration Hydraulic Conductivity Test Data Summary
 Unocal Edmonds Bulk Fuel Terminal Lower Yard
 11720 Unoco Road
 Edmonds, Washington

Well ID	Date	Pump Used	Initial DTW (feet)	Flow Rate (GPM)	Maximum Drawdown (feet)	Notes
MW-104	5/16/2011	2" Submersible Pump	7.73	3.0	5.18	Test terminated after 88 minutes.
MW-129R	5/17/2011	2" Submersible Pump	5.10	0.30	4.39	Test terminated after 60 minutes.
MW-149R	5/16/2011	2" Submersible Pump	6.45	2.0	4.24	Test terminated after 60 minutes.
MW-500	5/13/2011	2" Submersible Pump	3.79	0.30	7.32	Well pumped dry.
	5/13/2011	2" Submersible Pump	3.79	0.25	7.75	Well pumped dry.
LM-2	5/17/2011	2" Submersible Pump	1.20	0.30	5.40	Well pumped dry.
	5/17/2011	2" Submersible Pump	1.20	0.20	5.44	Well pumped dry.
MW-518	5/17/2011	2" Submersible Pump	8.71	2.5	3.28	Test terminated after 90 minutes.
MW-8R	5/16/2011	2" Submersible Pump	7.70	5	0.62	Test terminated after 60 minutes.

Notes:

DTW: Depth to water

btoc: below top of casing

GPM: Gallons per minute

TABLE 5
Long Term Hydraulic Conductivity Test Data Summary
 Unocal Edmonds Bulk Fuel Terminal Lower Yard
 11720 Unoco Road
 Edmonds, Washington

Well ID	Date	Pump Used	Initial DTW (feet)	Flow Rate (GPM)	Maximum Drawdown (feet)	Notes
MW-8R	5/19/11 - 5/20/11	2" Submersible Pump	7.65	5.0	0.88	Test conducted for 24hrs, with no stoppages. Flow rate was confirmed every hour.
MW-521	5/19/11 - 5/20/11	NA	6.01	NA	no measurable drawdown	observation well
MW-522	5/19/11 - 5/20/11	NA	7.69	NA	no measurable drawdown	observation well
MW-523	5/19/11 - 5/20/11	NA	7.38	NA	no measurable drawdown	observation well

Notes:

DTW: Depth to water

btoc: below top of casing

GPM: Gallons per minute

NA: Not Applicable

TABLE 7
Detention Basin No.2 Investigation Soil Sample Analytical Results
Unocal Edmonds Bulk Fuel Terminal Lower Yard
11720 Unoco Road
Edmonds, Washington

Sample ID	Sample Depth (feet bgs)	Date Sampled	BTEX (mg/kg)				Total cPAHs Adjusted for Toxicity (mg/kg)	Diesel Range Organics (mg/kg)	Gasoline Range Organics (mg/kg)	Heavy Oil (Lube) (mg/kg)	Total TPH (mg/kg)
			B	T	E	X					
Site Soil Remediation Level (REL)/Cleanup Level (CUL) (mg/kg)			18	--	--	--	0.14	--	--	--	2975
B1-4.5-5	4.5-5	08/22/11	0.0022 U	NA	NA	NA	0.00052	3.1 U X	1.1 U	14 X	16
B1-9.5-10	9.5-10	08/22/11	0.23 W	NA	NA	NA	0.0082	5.3	25 W	42	72
B1-14-14.5	14-14.5	08/22/11	0.17	NA	NA	NA	N/A	4.8 U	2.1 U	16 U	11 UU
B2-4-4.5	4-4.5	08/22/11	0.018 UW	NA	NA	NA	0.051	620	9.2 U W	720	1,345
B2-7-7.5	7-7.5	08/22/11	0.0020 U	NA	NA	NA	0.00073	30	1 U	37	68
B2-9.5-10	9.5-10	08/22/11	0.0019 U	NA	NA	NA	0.002	100	16	100	216
B2-12-12.5	12-12.5	08/22/11	0.0020 U	NA	NA	NA	0.00088	130	2	530	662
B2-14.5-15	14.5-15	08/22/11	0.0024 U	NA	NA	NA	N/A	3.4 U	1.2 U	11 U	8 UU
B3-4.5-5	4.5-5	08/22/11	0.0022 U	NA	NA	NA	N/A	3.2 U	1.1 U	11 U	8 UU
B3-7-7.5	7-7.5	08/22/11	0.0021 U	NA	NA	NA	0.00076	110 X	1.1 U	70 X	181
B3-12-12.5	12-12.5	08/22/11	0.0020 U	NA	NA	NA	0.00077	43 X	6.8	46 X	96
B3-14-14.5	14-14.5	08/22/11	0.0040	NA	NA	NA	N/A	3.3 U	1.3	11 U	8
B4-4.5-5	4.5-5	08/22/11	0.0020 U	NA	NA	NA	0.00053 UU	160	1 U	53 U	187
B4-9.5-10	9.5-10	08/22/11	0.024 W	NA	NA	NA	0.0075	2,900	13 W	1,500	4,413
B4-13-13.5	13-13.5	08/22/11	0.010	NA	NA	NA	0.0006	4.2	1.8	12 U	12
B4-14.5-15	14.5-15	08/22/11	0.021 U W	NA	NA	NA	N/A	3.6 U	11 U W	12 U	13 UU
B5-4.5-5	4.5-5	08/22/11	0.0022 U	NA	NA	NA	N/A	3.5 U	1.1 U	12 U	8 UU
B5-9-9.5	9-9.5	08/22/11	0.083 U W	NA	NA	NA	0.0138	16,000	42 U W	11,000	27,021
B5-11.5-12	11.5-12	08/22/11	0.0023 U	NA	NA	NA	N/A	3.8 U	1.2 U	13 U	9 UU
B5-13.5-14	13.5-14	08/22/11	0.0024 U	NA	NA	NA	N/A	3.7 U	1.2 U	12 U	8 UU
B6-4.5-5	4.5-5	08/22/11	0.021 U W	NA	NA	NA	0.09	470	190 W	310	970
B6-7-7.5	7-7.5	08/22/11	0.55 U	NA	NA	NA	0.36	16,000 Y	720	4,900 Y	21,620
B6-9-9.5	9-9.5	08/22/11	0.97	NA	NA	NA	3.2 T	170,000 Y	2,400	48,000 Y	220,400
B6-11-11.5	11-11.5	08/22/11	0.023 U W	NA	NA	NA	0.012	230 Z	30 W	57 Z	317
B6-13-13.5	13-13.5	08/22/11	0.0028 U	NA	NA	NA	N/A	3.5 U	1.4 U	12 U	8 UU

TABLE 7
Detention Basin No.2 Investigation Soil Sample Analytical Results
Unocal Edmonds Bulk Fuel Terminal Lower Yard
11720 Unoco Road
Edmonds, Washington

Sample ID	Sample Depth (feet bgs)	Date Sampled	BTEX (mg/kg)				Total cPAHs Adjusted for Toxicity (mg/kg)	Diesel Range Organics (mg/kg)	Gasoline Range Organics (mg/kg)	Heavy Oil (Lube) (mg/kg)	Total TPH (mg/kg)
			B	T	E	X					
Site Soil Remediation Level (REL)/Cleanup Level (CUL) (mg/kg)			18	--	--	--	0.14	--	--	--	2975
B7-4.5-5	4.5-5	08/22/11	0.083 U W	NA	NA	NA	0.071	260	230 W	210	700
B7-8-8.5	8-8.5	08/22/11	1.5 U W	NA	NA	NA	2.8 T	72,000	1,400 W	38,000	111,400
B7-9.5-10	9.5-10	08/22/11	0.030 U W	NA	NA	NA	0.037 T	4,200	47 W	1700	5947
B7-14-14.5	14-14.5	08/22/11	0.0021 U	NA	NA	NA	N/A	3.6 U	1 U	12 U	8 UU
B8-4.5-5	4.5-5	08/23/11	0.24 U T	NA	NA	NA	0.114	11,000	1,000	4,500	16,500
B8-7.5-8	7.5-8	08/23/11	0.0029	NA	NA	NA	0.077	6,800	260	2,300	9,360
B8-9.5-10	9.5-10	08/23/11	3.2	NA	NA	NA	0.5 T	50,000	730	25,000	75,730
B8-11-11.5	11-11.5	08/23/11	0.51 W	NA	NA	NA	0.09	4,900	300 W	3,000	8,200
B8-13.5-14	13.5-14	08/23/11	0.0073	NA	NA	NA	0.1	40	1.2 U	14	55
B8-14.5-15	14.5-15	08/23/11	0.0056	NA	NA	NA	N/A	3.5 U	1.2 U	12 U	8 UU
B9-4.5-5	4.5-5	08/23/11	0.0022 U	NA	NA	NA	N/A	3.2 U	1.1 U	27	29
B9-8.5-9	8.5-9	08/23/11	0.023 U W	NA	NA	NA	0.29	14,000	270 W	6,700	20,970
B9-9.5-10	9.5-10	08/23/11	0.0025 U	NA	NA	NA	0.0024	23	1.2 U	12 U	30
B9-10.5-11	10.5-11	08/23/11	0.0030 U	NA	NA	NA	0.025	640	1.5 U	280	921
B9-11-11.5	11-11.5	08/23/11	1.1 W	NA	NA	NA	0.15 T	11,000	950 W	4,300	16,250
B9-12.5-13	12.5-13	08/23/11	0.0026 U V	NA	NA	NA	0.00065	8.3	1.3 U	13 U	15
B10-0.5-1	0.5-1	08/25/11	0.030 U W	NA	NA	NA	0.2	360	15 U W	390	758
B10-1.5-2	1.5-2	08/25/11	0.046 U W	NA	NA	NA	0.018	12	23 U W	62	86
B10-2.5-3	2.5-3	08/25/11	0.030 U W	NA	NA	NA	0.00068 UU	4.1 U	15 U W	27	37
B10-3.5-4	3.5-4	08/25/11	0.0037 U V	NA	NA	NA	0.00072	15	1.8 U V	41	57
B11-4.5-5	4.5-5	08/23/11	0.0027 U	NA	NA	NA	0.24	360	1.3 U U	650	1,011
B11-7.5-8	7.5-8	08/23/11	0.25 U W	NA	NA	NA	0.012	24,000 S	240 W	11,000	35,240
B11-8.5-9	8.5-9	08/23/11	0.15 U W	NA	NA	NA	0.012	7.5	75 U W	15 U	53
B11-9.5-10	9.5-10	08/23/11	0.0034	NA	NA	NA	1.6 T	5.3	1.3 U	12 U	12
B11-10-10.5	10-10.5	08/23/11	0.1 U W	NA	NA	NA	3.4	25,000	150 W	12,000	37,150
B11-11-11.5	11-11.5	08/23/11	0.0042 U V	NA	NA	NA	0.01	310	2.1 U	150	461
B11-13.5-14	13.5-14	08/23/11	0.002 U	NA	NA	NA	N/A	3.5 U	1 U	12 U	8 UU

TABLE 7
Detention Basin No.2 Investigation Soil Sample Analytical Results
Unocal Edmonds Bulk Fuel Terminal Lower Yard
11720 Unoco Road
Edmonds, Washington

Sample ID	Sample Depth (feet bgs)	Date Sampled	BTEX (mg/kg)				Total cPAHs Adjusted for Toxicity (mg/kg)	Diesel Range Organics (mg/kg)	Gasoline Range Organics (mg/kg)	Heavy Oil (Lube) (mg/kg)	Total TPH (mg/kg)
			B	T	E	X					
Site Soil Remediation Level (REL)/Cleanup Level (CUL) (mg/kg)			18	--	--	--	0.14	--	--	--	2975
B12-0.5-1	0.5-1	08/24/11	0.033 U W	NA	NA	NA	0.0117	140	17 U W	150	299
B12-1-1.5	1-1.5	08/24/11	0.038 U W	NA	NA	NA	0.00072 UU	120	34 W	100	254
B12-2.5-3	2.5-3	08/24/11	0.051 U W	NA	NA	NA	0.079	160	25 U W	75	248
B12-3.5-4	3.5-4	08/24/11	0.0028 U	NA	NA	NA	0.00063	4.1	1.4 U	28	33
B13-4.5-5	4.5-5	08/23/11	0.025 U W	NA	NA	NA	0.0046	11	12 U W	64	81
B13-6-6.5	6-6.5	08/23/11	0.031 U W	NA	NA	NA	0.036	110	15 U W	250	368
B13-7-7.5	7-7.5	08/23/11	0.16 U W	NA	NA	NA	0.054 R	12,000	200 W	7,400 U	15,900
B13-9-9.5	9-9.5	08/23/11	0.018	NA	NA	NA	N/A	3.7 U	1.3 U	12 U	9 UU
B13-10-10.5	10-10.5	08/23/11	0.071 U W	NA	NA	NA	0.026	1,300	110 W	740	2,150
B13-11.5-12	11.5-12	08/23/11	0.0056	NA	NA	NA	N/A	4 U	1.4 U	13 U	9 UU
B14-0.5-1	0.5-1	08/25/11	0.11 U W	NA	NA	NA	0.029	16	57 U W	110	155
B14-1.5-2	1.5-2	08/25/11	0.023 U W	NA	NA	NA	N/A	NA	11 U W	NA	6 UU
B14-2.5-3	2.5-3	08/25/11	0.051 U W	NA	NA	NA	N/A	5 U	25 U W	17 U	24 UU
B14-3.5-4	3.5-4	08/25/11	0.058 U W	NA	NA	NA	0.0009	7.4	29 U W	76	98
B15-4.5-5	4.5-5	08/23/11	0.0025 U	NA	NA	NA	0.0005	4.5	1.3 U	17	22
B15-6.5-7	6.5-7	08/23/11	0.0026 U V	NA	NA	NA	N/A	3.6 U	1.3 U	18	20
B15-8.5-9	8.5-9	08/23/11	0.0048 U V	NA	NA	NA	0.0008	7.8	2.4 U	54	63
B15-11-11.5	11-11.5	08/23/11	0.029 U W	NA	NA	NA	N/A	4 U	15 U W	13 U	16 UU
B16-3.5-4	3.5-4	08/24/11	0.023 U W	NA	NA	NA	0.018	100	11 U W	280	386
B16-4-4.5	4-4.5	08/24/11	0.27 U W	NA	NA	NA	0.1	280	140 U W	940	1,290
B16-4.5-5	4.5-5	08/24/11	0.0024 U	NA	NA	NA	0.00123	4	1.2 U	12 U	11
B16-6-6.5	6-6.5	08/24/11	0.0031 U	NA	NA	NA	N/A	3.9 U	1.5 U	13 U	9 UU
B17-3.5-4	3.5-4	08/24/11	0.025 U W	NA	NA	NA	0.00109	550	12 U W	1,200	1,756
B17-4-4.5	4-4.5	08/24/11	0.0066	NA	NA	NA	0.0008 UU	14,000	2.3 U	8,200	22,201
B17-4.5-5	4.5-5	08/24/11	0.34 U W	NA	NA	NA	116 R	55	170	43	268
B17-5.5-6	5.5-6	08/24/11	0.033 U W	NA	NA	NA	N/A	4.3 U	17 U W	14 U	18 UU

TABLE 7
Detention Basin No.2 Investigation Soil Sample Analytical Results
 Unocal Edmonds Bulk Fuel Terminal Lower Yard
 11720 Unoco Road
 Edmonds, Washington

Sample ID	Sample Depth (feet bgs)	Date Sampled	BTEX (mg/kg)				Total cPAHs Adjusted for Toxicity (mg/kg)	Diesel Range Organics (mg/kg)	Gasoline Range Organics (mg/kg)	Heavy Oil (Lube) (mg/kg)	Total TPH (mg/kg)
			B	T	E	X					
Site Soil Remediation Level (REL)/Cleanup Level (CUL) (mg/kg)			18	--	--	--	0.14	--	--	--	2975

Notes:

BTEX analyzed by EPA Method 8021B.
 cPAHs analyzed by EPA Method 8270 SIM.
 Gasoline analyzed by method NWTPH-G.
 Diesel and Heavy Oil (Lube) analyzed by method NWTPH-D Extended.
 Total TPH calculated by summing the concentrations of gasoline, diesel and heavy oil. If one or more TPH constituents were reported as Non-Detect, half of the reporting limit value was added to the total.

cPAHs adjusted for toxicity according to WAC 173-340-708(8) and *Air Toxics Hot Spots Program Risk Assessment Guidelines, Part II Technical Support Document for Describing Available Cancer Potency Factors*. Office of Environmental Health Hazard Assessment, California EPA, May 2005. If one or more adjusted cPAH constituents were reported as Non-Detect, half of the reporting limit was used in calculations.

Highlighted cells indicate concentration exceeds REL or CUL.

NA = Indicates analysis not conducted.

[] = Bracketed data indicate duplicate sample.

BTEX = Benzene, toluene, ethylbenzene, and total xylenes

EPA = Environmental Protection Agency

mg/kg = Milligrams per kilogram

cPAHs = Carcinogenic polynuclear aromatic hydrocarbons

REL = Remediation level

CUL = Cleanup level

TPH = Total petroleum hydrocarbons

Lab Qualifiers Definition

J	Indicates an estimated value.
JZ	Detected hydrocarbons in the gasoline range appear to be due to overlap of diesel range hydrocarbons.
R	The GC/MS semivolatiles internal standard peak areas were outside of the QC limits for both the initial injection and the re-injection. The values here are from the initial injection of the sample
S	Due to the nature of the sample extract matrix, the extract could only be concentrated to a final volume of 10ml instead of the usual volume of 5ml. The reporting limits were raised accordingly
T	Reporting limits were raised due to interference from the sample matrix
U	The compound was analyzed for but not detected. The associated value is the compound quantitation limit.
UU	The constituents making up the total are all non-detects.
V	The recovery for the sample surrogate is outside the QC acceptance limits as noted on the QC Summary. A reanalysis was not performed to confirm a matrix effect
W	Reporting limits were raised due to sample foaming
X	The LCS recovery is outside the QC limits. Results from the re-extraction are within the limits. The hold time had expired prior to the re-extraction; therefore, all results are reported from the original extraction. Similar results were obtained in both extracts.
Y	Due to dilution of the sample extract, capric acid recovery could not be determined.
Z	The capric acid reverse surrogate recovery is 0%

TABLE 8
LNAPL Baildown Test Log
 Unocal Edmonds Bulk Fuel Terminal Lower Yard
 11720 Unoco Road
 Edmonds, Washington

Site Name	Edmonds Terminal	Test Well ID	MW-510			
Date and Time In	8/24/11 7:30 AM	Date and Time Out	8/24/11 3:00 PM			
Personnel	Scott Zorn/Seamas McGuire	Weather	Sun			
Well Construction Details						
Top of Casing Elevation (ft amsl)	12.53	Screen Slot Size (in)	0.01			
Total Well Depth (ft)	13	Filter Pack Type	#2/12 silica			
Depth to Top of Screen (ft)	3	Depth to Bottom of Screen (ft)	13			
Well Casing Diameter (in)	2	Borehole Diameter (in)	8			
Initial Test Conditions						
Static Depth to LNAPL (ft)	7.06	Test Date	8/24/2011			
Static Depth to Water (ft)	7.07	Start Time	7:45 AM			
LNAPL Thickness (ft)	0.01	Initial LNAPL Volume in Well (gal)	0.0016			
LNAPL Removal Information						
LNAPL Removal Method/Equipment	Bailer	Time LNAPL Removal Begins	7:53 AM			
Volume of LNAPL Removed (gal)	0.0016	Time LNAPL Removal is Completed	7:53 AM			
Volume of Groundwater Removed (gal)	0.0044					
Baildown Test Data						
Elapsed Time (min)	Time	Depth to LNAPL (ft)	Depth to Water (ft)	Ground Water Elevation (ft)	Tide Elevation (Ft above Mean Lower Low Water)	Observations
2	7:55 AM	7.1	7.1	5.43	0.4264	LNAPL appears to have a darker color and lower viscosity
3	7:56 AM	7.11	7.11	5.42	0.4264	
5	7:58 AM	7.1	7.1	5.43	0.4592	Much darker in color
7	8:00 AM	7.09	7.09	5.44	0.4592	
9	8:02 AM	7.09	7.09	5.44	0.492	
11	8:04 AM	7.09	7.09	5.44	0.492	
13	8:06 AM	7.1	7.1	5.43	0.5248	
15	8:08 AM	7.1	7.1	5.43	0.5248	
22	8:15 AM	7.1	7.1	5.43	0.5904	
25	8:28 AM	7.1	7.11	5.42	0.7544	
30	8:33 AM	--	7.12	5.41	0.8528	
35	8:38 AM	--	7.12	5.41	0.9184	LNAPL on probe - DTP not measured
45	8:48 AM	7.13	7.13	5.4	1.0824	
55	8:58 AM	7.13	7.13	5.4	1.2464	
65	9:08 AM	7.15	7.15	5.38	1.4432	LNAPL on probe - DTP not measured
75	9:18 AM	--	7.15	5.38	1.6728	
85	9:28 AM	--	7.16	5.37	1.9024	Very small amount of LNAPL on probe
95	9:38 AM	--	7.18	5.35	2.1648	No LNAPL on probe
105	9:48 AM	--	7.16	5.37	2.3944	Very small amount on probe
115	9:58 AM	--	7.17	5.36	2.6568	very small amount of LNAPL
125	10:08 AM	--	7.17	5.36	2.9848	Very small amount of LNAPL
135	10:18 AM	--	7.17	5.36	3.2472	Very small amount of LNAPL
145	10:28 AM	--	7.17	5.36	3.5424	Very small amount of LNAPL
155	10:38 AM	--	7.17	5.36	3.8704	Very small amount of LNAPL
165	10:48 AM	--	7.17	5.36	4.1656	Very small amount of LNAPL
175	10:58 AM	7.17	7.17	5.36	4.4936	LNAPL on probe - sheen
185	11:08 AM	--	7.16	5.37	4.7888	Small LNAPL on probe
300	1:03 PM	--	7.05	5.48	8.0688	very small amount on tip
389	2:22 PM	--	6.86	5.67	9.348	very small amount on tip
423	3:14 PM	--	6.79	5.74	9.7088	very small amount on tip



2012 Final Conceptual Site Model

TABLE 7
Sediment Sample Analytical Results - June 2012
Unocal Edmonds Bulk Fuel Terminal Lower Yard
11720 Unoco Road
Edmonds, Washington

Chemical	Units	Sample ID			US-100	DUP-1	US-101	US-102				
		SQS ¹	CSL ¹	LAET ²	7/30/2012	7/30/2012	7/30/2012	7/30/2012				
Volatile Organic Compounds												
Benzene	mg/kg	NA	NA	NA	0.002	U	0.001	U	0.004	U	0.003	U
Ethylbenzene	mg/kg	NA	NA	NE	0.004	U	0.003	U	0.009	U	0.005	U
Toluene	mg/kg	NA	NA	NA	0.004	U	0.003	U	0.009	U	0.005	U
Xylene (Total)	mg/kg	NA	NA	NE	0.004	U	0.003	U	0.009	U	0.005	U
Petroleum Hydrocarbons												
GRO	mg/kg	NA	NA	NA	45	U	41	U	140	U	100	U
DRO	mg/kg	NA	NA	NA	7.7	U	11		29		17	
HO	mg/kg	NA	NA	NA	26	U	59		170		110	
Metals												
Arsenic	mg/kg	57	93	130	8.53		6.87		29.1		20.2	
Copper	mg/kg	390	390	390	5.7		5.05		43.6		21.6	
Lead	mg/kg	450	530	430	11.2		10		107		60.6	
Zinc	mg/kg	410	960	460	51.5		41.4		319		144	
Conventionals												
TOC	mg/kg	NA	NA	NA	19200		18800		64700		65200	
TOC	%	NA	NA	NA	2		2		6		7	
Moisture	%	NA	NA	NA	60.8		60.2		83.6		77.5	
Ammonia-Nitrogen	mg/kg	NA	NA	NA	148		163		863		402	
PAHs³												
Acenaphthene	mg/kg	16	57	0.13	0.27	U	0.27	U	0.012	U	0.0089	U
Acenaphthylene	mg/kg	66	66	0.07	0.57		0.34		0.014		0.013	
Anthracene	mg/kg	220	1200	0.28	0.45		0.39		0.034		0.023	
Benzo(a)anthracene	mg/kg	110	270	0.96	0.63		0.64		0.16		0.061	
Benzo(a)pyrene	mg/kg	99	210	1.10	0.68		0.69		0.22		0.084	
Benzo(b)fluoranthene	mg/kg	NA	NA	NA	1.15		1.22		0.42		0.15	
Benzo(g,h,i)perylene	mg/kg	31	78	0.67	0.89		0.69		0.19		0.067	
Benzo(k)fluoranthene	mg/kg	NA	NA	NA	0.36		0.44		0.14		0.06	
Chrysene	mg/kg	110	460	0.95	0.94		1.01		0.28		0.11	
Dibenz(a,h)anthracene	mg/kg	12	33	0.23	0.27	U	0.27	U	0.042		0.015	
Fluoranthene	mg/kg	160	1200	1.30	2.40		2.29		0.46		0.21	
Fluorene	mg/kg	23	79	0.12	0.45		0.53		0.059		0.028	
Indeno(1,2,3-cd)pyrene	mg/kg	34	88	0.60	0.68		0.53		0.17		0.057	
Naphthalene	mg/kg	99	170	0.23	2.92		1.38		0.052		0.059	
Phenanthrene	mg/kg	100	480	0.66	2.29		1.91		0.18		0.11	
Pyrene	mg/kg	1000	1400	2.40	2.34		2.18		0.44		0.19	
Total LPAH ⁴	mg/kg	370	780	1200	6.68		4.55		0.34		0.23	
Total HPAH ⁵	mg/kg	960	5300	7900	10.05		9.69		2.52		1.00	

Notes:

PAH = Polycyclic aromatic hydrocarbons

LPAH = low molecular weight PAH

HPAH = high molecular weight PAH

SQS = Sediment Quality Standards

CSL = Cleanup Screening Levels

NA = Not applicable

NE= Not evaluated because these analytes do not have SQS or CSL.

U = Indicates the value was below the Method Detection Limit.

1. SQS and CSL from Chapter 173-204 WAC Sediment Management Standards. PAH results for US-100 and DUP-1 are organic carbon normalized.

2. LAET from Puget Sound Dredged Disposal Analysis. 1996. Progress Re-evaluation Puget Sound Apparent Effects Thresholds (AETs). LAET value is the lowest concentration of the echinoderm, microtox, and oyster AETs from Table 9.

3. Samples US-100 and DUP-1 required normalization as TOC fell in the range of 0.2 to 4%. PAH values were normalized by dividing the original concentration by the TOC percentage expressed as a decimal.

4. Total LPAH is the sum of naphthalene, acenaphthylene, acenaphthene, fluorene, phenanthrene, and anthracene. Non-detect values are treated as zero in the summation.

5. Total HPAH is the sum of fluoranthene, pyrene, benz(a)anthracene, chrysene, total benzofluoranthenes, benzo(a)pyrene, indeno(1,2,3-c,d)pyrene, dibenzo(a,h)anthracene, and benzo(g,h,i)perylene. Non-detect values are treated as zero in the

6. US-100 and DUP-1 were compared to SQS and CSL screening criteria and US-101 and US-102 were compared to LAET based on TOC concentrations and Ecology guidance (Washington Department of Ecology. 1992 and 1993. Organic Carbon Normalization of Sediment Data)

7. All results are reported on a dry weight basis except as indicated in footnote 3.

ARCADIS

Appendix B

Soil Vapor Sampling Procedures



Soil Vapor & Indoor Air Sampling Technical Toolkit

Version 1.8

This work was funded by Chevron Environmental Management Company and performed by Chevron Energy Technology Company, Health, Environment and Safety Group, Environmental Unit.

Copyright© 2013 Chevron Energy Technology Company. All Rights Reserved. This report and its appendices are intended to be used by those conducting work for Chevron Environmental Management Company and Chevron Corporation

**Tom Peargin, Senior Staff Hydrogeologist
Ravi Kolhatkar, Staff Environmental Hydrogeologist
Hong (Emma) Luo, Environmental Hydrogeologist**

**Environmental Unit
Health, Environment and Safety Department
Chevron Energy Technology Company**

March 20, 2013



TABLE OF CONTENTS

1	INTRODUCTION	4
2	SOIL VAPOR PROBE INSTALLATION.....	4
2.1	PERMANENT VS. TEMPORARY PROBES	4
2.2	BOREHOLE CLEARANCE	5
2.3	WATER TABLE ELEVATION AND SOIL VAPOR SAMPLING PROBE DEPTH	5
2.4	SINGLE VS. MULTILEVEL SOIL VAPOR SAMPLING.....	5
2.5	SOIL VAPOR PROBE INSTALLATION USING HOLLOW-STEM AUGERS	6
2.5.1	<i>Soil Sample Collection.....</i>	<i>6</i>
2.5.2	<i>Soil Vapor Sampling Probe Construction</i>	<i>6</i>
2.6	SOIL VAPOR SAMPLING USING DIRECT-PUSH TECHNIQUES.....	8
2.6.1	<i>Temporary Direct-Push Soil Vapor Sampling (Post-Run Tubing System).....</i>	<i>8</i>
2.6.2	<i>Permanent Direct-push Soil Vapor Sampling Probes.....</i>	<i>9</i>
3	NEAR-SLAB SOIL VAPOR SAMPLING.....	11
3.1	SAMPLING EQUIPMENT.....	12
3.2	FIELD ACTIVITIES PRIOR TO SAMPLING/DOCUMENTATION	14
3.3	EQUILIBRATION TIME.....	15
3.4	EVALUATING LEAKS IN SAMPLING TRAIN.....	15
3.4.1	<i>Shut-in Test.....</i>	<i>16</i>
3.4.2	<i>Leak Test.....</i>	<i>16</i>
3.4.2.1	<i>Leak test tracer</i>	<i>16</i>
3.4.2.2	<i>Leak test using helium as a tracer</i>	<i>17</i>
3.5	PURGING	18
3.6	SAMPLE COLLECTION	20
3.6.1	<i>Vacuum And Flow Rate Considerations.....</i>	<i>20</i>
3.6.2	<i>Other Sampling Considerations</i>	<i>21</i>
4	SUB-SLAB VAPOR SAMPLING	22
4.1	SUB-SLAB SOIL VAPOR PROBE INSTALLATION.....	22
4.2	SUB-SLAB SOIL VAPOR SAMPLING TRAIN TESTS, PURGING AND SAMPLING	24
5	INDOOR AND AMBIENT (OUTDOOR) AIR SAMPLING.....	24
5.1	INDOOR AIR SAMPLING.....	26
5.2	OUTDOOR AMBIENT AIR SAMPLING.....	27
6	ANALYTICAL TECHNIQUES.....	28
6.1	VOCs/SVOCs	30
6.2	FIXED GASES.....	31
6.3	DATA REPORTING.....	31
7	REFERENCES	32



FIGURES

Figure 1. Augered, permanent multilevel soil vapor sampling probe (by Chuck Zuspan, ETC).....	7
Figure 2. Direct-push soil vapor sampling probe (PRT; Geoprobe ®).....	10
Figure 3. Direct-push soil vapor sampling probe (implant type; Geoprobe®).....	11
Figure 4. Swagelok® connectors (image from equipsales.com)	12
Figure 5. Picture of a sampling system for soil gas sampling train leak test, soil gas purging and sampling (Adapted from ARCADIS)	13
Figure 6. 6 L Summa™ canister with ¼” stainless steel bellows valve (image from Air Toxics Ltd.).....	14
Figure 7. Helium shroud is used for leak-testing soil vapor sampling train.	19
Figure 8. Soil vapor sampling train using two Summa canisters for a sample and a duplicate sample (Adapted from ENSR)	22
Figure 9. (a)Drilling through a slab, and (b) inner and outer holes (EPA).	25
Figure 10. (a) Stainless steel sub-slab vapor probe components; (b) general schematic of sub-slab vapor probe and (c) completed sub-slab vapor probe. (EPA)	25
Figure 11. VOC concentrations in background indoor air compared to RBC.....	26
Figure 12. Vertical profile of benzene, O ₂ , and CO ₂	32

TABLES

Table 1. Pros and Cons for direct-push technique over hollow-stem auger for probe installation.....	10
Table 2. Flow rates (mL/min) for given sampling time intervals using the flow controller (from Air Toxics Ltd.)	20
Table 3. Common Household Sources of Background Indoor Air Contamination (Adapted from NJDEP, 2005).....	29
Table 4. (a) Required analytes for different samples and (b) recommended analytical methods used for several common analytes (Adapted from API 2005).	30



1 INTRODUCTION

The Chevron (CVX) Soil Vapor Sampling Technical Toolkit provides technical guidance to suppliers conducting vapor migration pathway (VIP) investigations at petroleum hydrocarbon contaminated sites. The toolkit is a collation of identified “best practices” in planning and conducting soil vapor surveys. Maintaining consistency in best practices across the Chevron portfolio is a primary driver for this toolkit, as this will enhance the defensibility of the soil vapor data gathered at these sites. The toolkit is intended to remain “evergreen”: that is, as new best practices are developed, the toolkit will be edited to incorporate those developments. In this manner the most up-to-date technologies and methods can be implemented in the field.

The toolkit is primarily focused on petroleum hydrocarbon impacted sites; that is, sites where biodegradation of vapor phase contaminants can play a role in attenuation. However, many elements of the toolkit can also be applied at sites where biodegradation of vapor phase contaminants is unlikely to occur (e.g., chlorinated solvent contaminated sites). The toolkit is organized into sections focusing on soil vapor sampling probes, soil vapor sampling, analytical techniques, and data reporting. Diagrams are included to provide further description of the processes and equipment discussed. Further technical information and advice is available by contacting the Chevron Energy Technology Co. VIP Team members:

Tom Peargin, Senior Staff Hydrogeologist, tpeargin@chevron.com, 925-842-5586

Ravi Kolhatkar, Staff Environmental Hydrogeologist, kolhatrv@chevron.com, 713-954-6082

Hong (Emma) Luo, Environmental Hydrogeologist, Emma.Hong.Luo@chevron.com, 713-954-6101

2 SOIL VAPOR PROBE INSTALLATION

All standard protocols required before initiating any drilling activities (e.g., regulatory permits, underground utility markings, clearances from overhead lines etc.) need to be followed when preparing the site for installation of soil vapor probes.

2.1 Permanent vs. Temporary Probes

Permanent soil vapor sampling probes are required for soil vapor surveys conducted for human health risk assessment to ensure that samples from a given location can be collected repeatedly. **Chevron recommends permanent probes to increase the accuracy and technical defensibility of samples used to assess human health risk.** Temporary probes (which are sampled only once) are suitable only for non-human health risk assessment soil vapor samples, such as in support of delineation of a vapor phase contaminant plume.

Permanent probes also facilitate repeated sampling rounds if this is deemed necessary to represent soil vapor concentrations during different seasons, during high and low water table conditions, or during periods of frozen ground. If a sample is only taken once at a



particular point, the result could be misleading due to variable water table elevations, and the variation of NAPL/air interaction that comes with these seasonal changes.

2.2 Borehole Clearance

The use of air knife for borehole clearance is not recommended for direct emplacement of soil vapor sampling points at shallow depths (e.g., 5 ft). This is because air knife utilizes high pressure air and is expected to significantly disturb the soil vapor profile around the installation, and it could take weeks to months for the profile to re-equilibrate (API 2005). Instead, hand auguring is preferred for installing soil vapor sampling points at a shallow depth of 5 ft.

Air knife borehole clearance (typically performed to a depth of 8 ft) is acceptable for installation of deeper soil vapor sampling points (10 ft deep or greater). Following the borehole clearance, these deeper points could be installed using either direct push or hollow stem auger methods.

2.3 Water Table Elevation and Soil Vapor Sampling Probe Depth

Prior to installing permanent soil vapor probes it is critical to review the historical range of site groundwater elevation data to determine the proper depth for probe installation. Soil vapor sampling probes should ideally be installed so that the vapor sampling screen is situated 2 to 3 ft above the historical high groundwater elevation, which will reduce the likelihood that the probe will be submerged during periods of elevated groundwater, and will enable the probe to sample that interval of the subsurface with the potentially highest soil vapor volatile organic compound (VOC) concentrations.

The US EPA and most state regulatory guidance require a minimum of 5 ft depth for the shallowest soil vapor sampling probes. For sites with shallow water tables (high water table elevation is within 5-7 ft of the surface) it is acceptable to place the soil vapor sampling probe at a depth of 5 ft, even though this depth may cause the point to be submerged, or occluded with water from the capillary fringe during certain portions of the season. **Placing soil vapor sampling points at depths less than 5 ft. should be performed only on an exception basis and with approval of Chevron Project Manager. When approval has been granted to install a soil vapor sampling point shallower than 5 ft, it is critical to take extra care to ensure there are no leaks due to potential short-circuiting from the surface.**

2.4 Single vs. Multilevel Soil Vapor Sampling

Chevron recommends installation of multilevel probes in order to understand the source of soil vapors (impacted vadose zone soil vs. impacted groundwater) and to qualitatively evaluate the depth and degree of biodegradation of soil vapors in the vadose zone (using concentration versus depth profiles of VOCs, methane, oxygen and carbon dioxide). In addition, several VI guidance documents (e.g., CA DTSC, 2011) recommend multilevel probe installation, with the sample containing the highest concentration (regardless of depth) used for comparison to Tier I screening tables.



EPA and most state regulatory guidance documents state that soil vapor samples used for vapor intrusion screening should not be collected shallower than 5 ft depth. Agency guidance states that this is intended to minimize the potential for short-circuiting of atmospheric air into soil vapor samples. **See section 2.3 for sites where depth to groundwater is about 5 ft or less from the ground surface or less.** The deepest probe should be installed 2 to 3 ft above the historical high groundwater elevation, with shallower probes installed at defined intervals above the deepest probe (e.g., 5 ft intervals). For example, at a site where the seasonal high groundwater elevation is 18 ft below grade, probes could be emplaced at depths of 15, 10, and 5 ft below grade.

2.5 Soil Vapor Probe Installation using Hollow-stem Augers

A conventional drill rig equipped with a hollow-stem auger should be used for permanent soil vapor probe installation. Use of methods such as roto-sonic, air rotary, or mud rotary drilling methods can influence soil vapor sample results and/or alter the physical properties of the subsurface adjacent to the sampling probe, although they may be necessary due to stratigraphic limitations (e.g., cobbles). **If roto-sonic, air rotary, or mud rotary drilling methods are deemed necessary they should be utilized only on an exception basis and with approval of the Chevron Project Manager.**

2.5.1 Soil Sample Collection

During drilling, soil cores should be collected for lithologic and stratigraphic description, and, **if required by CEMC project managers, for evaluation of soil porosity and moisture content (ASTM D2216) for potential vapor transport modeling.** Soil samples should be collected and preserved for off-site chemical and physical analyses. Sampling interval selection is site specific, based on stratigraphic heterogeneity and Chevron recommends continuous logging and taking soil sample at each lithology or planned screen interval. Chemical analyses are chosen based on the site contaminants, but typically would include TPHg and TPHd (EPA 8015B) and BTEX (EPA 8260B) for gasoline release sites. Undisturbed soil samples should be collected in stainless steel or brass liners and capped with Teflon[®] sheeting and plastic end caps and placed in re-sealable plastic bags. The liners should then be stored in iced coolers and transported to a certified laboratory under chain-of-custody documentation.

2.5.2 Soil Vapor Sampling Probe Construction

After the borehole is drilled to its maximum depth, the deepest soil vapor sampling probe is installed (Figure 1). Each sampling probe tip should be approximately 6 inches long, and of small diameter ($\frac{1}{4}$ -inch is typical) to minimize dead space within the probe. Screens constructed of stainless steel and PVC are acceptable. Each 6-inch-long screen tip is vertically centered in a 1-ft long interval containing standard sand pack, resulting in 3 inches of sand being above and below each screen. It is important to correctly size the sand pack for the probe screen diameter. Each sand pack is covered with a 1 ft interval of dry granular bentonite, which is then covered with ≥ 2 ft of hydrated granular bentonite slurry to the bottom of the next sand pack (i.e., the next sampling interval). The dry granular bentonite is emplaced immediately above the sand pack to ensure that hydrated



granular bentonite slurry does not flow down to the probe screen and seal it off from the adjacent soil. Following the emplacement of 1 ft of dry granular bentonite immediately

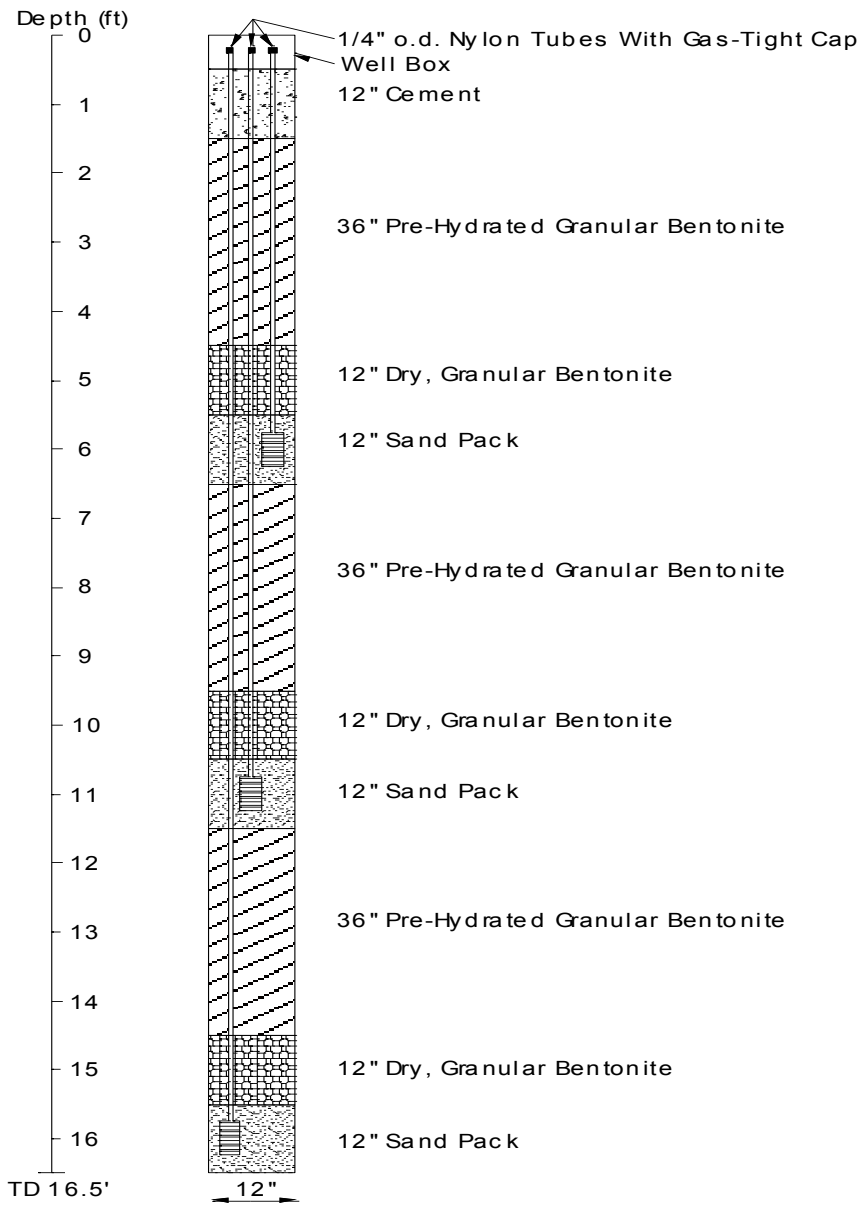

Figure 1. Augered, permanent multilevel soil vapor sampling probe (by Chuck Zuspan, ETC)

above the uppermost sampling interval (sand pack), the remainder of the borehole should be filled with hydrated granular bentonite slurry (mixed at the surface and poured in) and, at the top, a 1-ft cement cap. A flush-mounted, locked utility vault of sufficient size to contain the tubing lines should be set in the cement cap.



Probes should have screen and end caps fitted with a Swagelok[®] fitting connected to the upper end cap. Use chromatography-grade 316 stainless steel compression fittings to ensure that fitting materials are not a source of VOCs. Tubing should be ¼-inch outer diameter Teflon[®] or Nylon or stainless steel. Hose clamps, push-on barbed fittings, and other types of connectors should be avoided as they may not provide an air-tight seal. Two studies have been done to evaluate different types of tubing. Air Toxics (Hayes et al, 2006) conducted tests of three tubing types (Teflon[®], nylon, PEEK) that showed little difference in the tubing type with respect to cleanliness and inertness to the chemicals tested. Low-level blanks were detected in nylon, but the values were far below required soil-gas risk-based screening levels. An earlier study presented at a conference in 2004 (Ouellette, 2004) compared the adsorption of a hydrocarbon standard by five tubing types (Teflon[®], nylon, polyethylene, vinyl and flexible Tygon[®]). Nylon and Teflon[®] showed insignificant adsorption (<10%), but the others showed higher adsorption, especially the flexible tubing, where losses of the tested hydrocarbon standard were up to 80 percent. **For this reason, flexible tubing materials such as Polyethylene, vinyl and Tygon[®] are not acceptable for use at Chevron sites.**

Also very important is where the tubing is stored and how it is handled. Any type of tubing will become contaminated and contribute to false positives if it is stored near volatile chemicals. For this reason, all tubing should be new, carefully stored, and blank tested (see QA/QC section).

Each of the tubing lines must be clearly and permanently marked at the land surface to denote its corresponding screened interval. Do not use markers. Each tube must be fitted with a gas-tight, Swagelok[®] valve or cap at the ground surface to eliminate the potential for atmospheric air getting into the tubing. If a cap is used, it must be removed before sampling, which creates an opportunity for atmospheric air entry to the probe, so the period between removing the cap and assembling the sampling train should be as brief as possible and purging (discussed later in this toolkit) is required before sampling.

2.6 Soil Vapor Sampling using Direct-push Techniques

Single or multilevel soil vapor sampling can be performed with a direct-push rig (e.g., Geoprobe[®]) in certain soil type (e.g. non-clayey soil). These rigs can install permanent soil vapor sampling probes, or can be used to collect soil vapor data during a direct-push where no permanent probe is installed. **Chevron requires human health risk assessments to be performed with data collected from permanent soil vapor sampling probes** but soil vapor samples collected from tubing during a single push (temporary direct-push, e.g. Post-Run Tubing System) can be useful to delineate areas of elevated soil vapor concentrations, and can help identify location and depth of permanent soil vapor sampling probes if needed (but not for human health risk assessment).

2.6.1 Temporary Direct-Push Soil Vapor Sampling (Post-Run Tubing System)

Soil vapor surveys using direct push techniques (non-permanent installations) are sometimes useful in determining the depth and extent of localized petroleum hydrocarbon vapors, especially when sourced from residual soil contamination in the vadose zone.



Once delineated, these data can be used to determine the location of permanently installed sampling probes for human health risk assessment.

Temporary direct-push soil vapor concentration data does not represent the most technically defensible sampling available, since it is difficult to insure that samples from temporary direct-push probes have not leaked to the surface (which might yield false-negative data), and the technique precludes collection of multiple samples over time to verify the presence or absence of temporal variation. **As a result, use of temporary direct-push soil vapor sample data in assessing human health risk should only be considered on an exception basis and with approval of Chevron Project Manager.**

The Post-Run Tubing (PRT) system involves the use of a drive point holder (located just above the drive point) that also serves as the soil vapor sampling probe (Figure 2). Both expendable and retrievable drive point/drive point holder systems are available. The PRT system allows for soil vapor samples to be obtained from multiple depths from a single borehole during a single sampling event. First, the drill rods and drive point/drive point holder are pushed to the shallowest designated depth. Then, an adaptor connected to Teflon[®] or nylon (Nylaflo[®]) sampling tubing that extends to the ground surface is attached to the drive point holder. Leakage of atmospheric air through the drive rods into the drive point holder (the vapor sampling probe) is prevented by o-rings that are part of the adaptor assembly. After obtaining a soil vapor sample (described in Section 3), the adaptor/tubing assembly is removed, and the tubing is discarded. The drive point/drive point holder is then pushed deeper into the subsurface until the next designated sampling depth is reached. The adaptor/tubing assembly, with a new piece of tubing attached, is then connected to the drive point holder and the soil vapor sampling process is repeated. This process can be repeated over multiple depths, but if lower concentrations exist beneath high concentrations, the samples in the deeper interval may have a positive bias. With the expendable PRT system, the drive point/drive point holder assembly remains in the subsurface when the rods are withdrawn, while for the retrievable PRT system the entire apparatus is removed.

There is no sand pack or hydrated bentonite seal needed in the borehole annulus. However, there is potential for cross-contamination resulting from contaminants being pushed downward by the drilling rods. Avoid lateral movement of the drive rods during the push and sampling processes, and if the probe is deflected by cobbles, or wavering of the rig, it is preferable to remove the probe, and retry to obtain a linear unwavering entry to avoid leakage along the outer wall of the casing. To avoid potential surface leakage due to these difficulties, a surface seal of hydrated granular bentonite is recommended with the PRT system.

2.6.2 Permanent Direct-push Soil Vapor Sampling Probes

Direct-push techniques to install permanent soil vapor sampling probes involves use of a truck-mounted hydraulic ram to push hollow metal rods equipped with a drive point to a designated depth. Table 1 describes the advantages and disadvantages of using direct push techniques over hollow-stem auger for installing soil vapor probes.

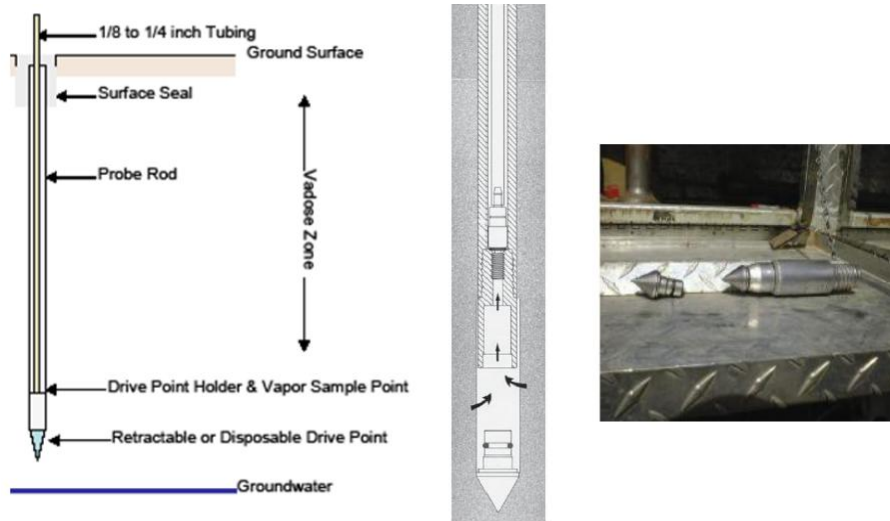

Figure 2. Direct-push soil vapor sampling probe (PRT; Geoprobe®)

Pro Direct Push	Con Direct Push
<ul style="list-style-type: none"> • Usually quicker and cheaper to install and cause less disruption to subsurface, therefore requires far less equilibration time prior to sampling. • Optimal for shallow-depth (up to about 20 ft), or in conjunction with an on-site, mobile laboratory enabling real-time adjustments to the sampling program. • Allows soil vapor sample collection very close to the building minimizing concern about interpolation or extrapolation of data to conditions beneath the building 	<ul style="list-style-type: none"> • Multi-level sampling requires larger footprint. • Likely to fail in some lithologies (e.g. soil with cobbles, calcified sediments etc). • Difficult to obtain soil samples for chemical and physical analyses. • Difficult to install sand packs and bentonite seals through direct push rods.

Table 1. Pros and Cons for direct-push technique over hollow-stem auger for probe installation.

The soil vapor sampling probes consist of an implant of tubular stainless steel screen with a length of 6 inches, outer diameter of ¼ inch, and typically a pore size of 0.0057 inches. Note that the implant is not retrievable and at site closure must be abandoned in place. The implant is connected to a Teflon® or nylon (Nylaflo®) sampling tube of sufficient length to reach the ground surface. A direct-push rig (i.e., Geoprobe®) is used to push a series of drive rods to a designated depth. When this depth is reached, the implant is slid down the bore of the drive rods and is attached to the drive point at the bottom. Then the drive rods are removed, leaving the implant and drive point in the subsurface (Figure 3).



As the drive rods are removed the borehole may collapse around the sampling probe. Also, as the drive rods are removed a sand pack can be installed around the implant, followed by a hydrated granular bentonite seal extending to the ground surface. A surface seal of hydrated granular bentonite is applied where the drive rods meet the ground surface.

One of the potential drawbacks of soil vapor sampling probe implants is the difficulty in installing a sand pack and hydrated granular bentonite seal through the drive rods as they are removed from the borehole. As a result, lateral movement of the sampling tubes and drive rods should be avoided to prevent atmospheric air from entering the soil vapor sample. Soil vapor probes installed using direct push technique as described above are acceptable for human health risk assessment.

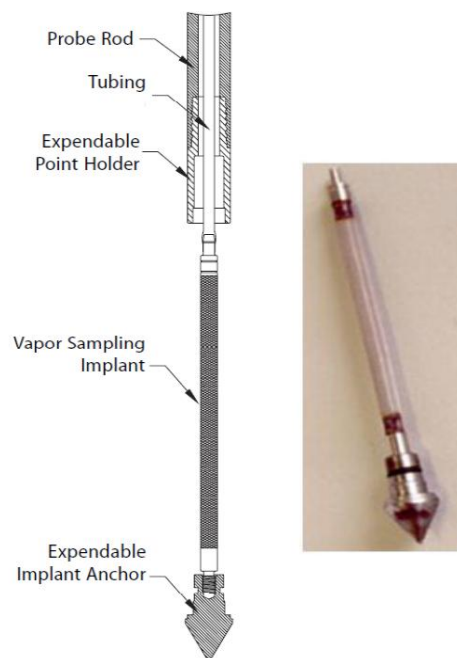

Figure 3. Direct-push soil vapor sampling probe (implant type; Geoprobe®).

3 NEAR-SLAB SOIL VAPOR SAMPLING

The proper collection of near-slab soil vapor samples is a critical step in producing reliable concentration data. A number of factors are important in ensuring the reliability of the data; each is discussed below. Note that some regulatory agencies have specific guidelines for soil vapor collection that may differ from those within the Chevron Sampling Toolkit. **Where possible, Chevron recommends following the Sampling Toolkit protocols unless specifically directed to do otherwise by local agencies.**

Prior to beginning a near-slab soil vapor sampling program, it is important to obtain the correct sampling equipment and to write a site-specific sampling plan. Written documentation of the equipment used and the sampling processes employed is critical.



Consistency in equipment and sampling processes between probe locations and between multiple sampling events is important in order to minimize potential discrepancies in soil vapor concentration data.

Chevron recommends that near-slab soil vapor probes be installed at a minimum two depths (when possible based on depth to groundwater) at each sampling location: one at a shallow depth (i.e. near ground surface, e.g. 5 ft bgs) and one at a deeper depth (i.e. close to groundwater capillary fringe). This is to help identify the likely source of soil vapors (from the groundwater or from contaminated soils in the vadose zone). Also, given the typical screening rationale for near slab soil vapor sampling, in general Chevron recommends conducting one round of near-slab soil vapor sampling (unless there is significant groundwater fluctuation at the site).

3.1 Sampling Equipment

Numerous types and combinations of tubing, connectors, valves, and pumps have been used for soil vapor sampling. The tubing, gauges, and pump (if any) should be connected by tubing that is flexible, air-tight, and has a low capacity for adsorption of VOC's. **Teflon[®] or Nylon tubing (marketed under the NylaFlow[®] name) with 1/4-” OD is recommended. Tygon[®], rubber, and Polyethylene tubing should not be used. Swagelok[®] type connectors/fittings (Figure 4) should be used for all connections between tubing and other sampling components to ensure that fitting materials are not a source of VOCs.** These connectors are air-tight and reliable. Hose clamps, push-on barbed fittings, and other types of connectors should be avoided as they may not provide an air-tight seal. The lack of an air-tight seal can allow air to enter the sample, thus diluting the vapor concentrations and compromising the integrity of the sample. Leak testing (discussed in Section 3.4) is used to ensure the integrity of soil vapor samples.

A vacuum must be created in order to draw the soil vapor to the ground surface. The vacuum can be created by a battery powered pump, a syringe, or a sampling container that is under a vacuum (such as a Summa[™] canister, discussed below). **If a pump is used, it is important to ensure that the sample collection point is on the intake side of the pump.** This will prevent any contaminants present in the pump from being drawn



Figure 4. Swagelok[®] connectors (image from equipsales.com)



into the vapor sample. A typical soil vapor sampling train using a helium shroud (for leak detection) and a flow-calibrated pump (for purging) is shown in Figure 5.

Although a number of sampling containers have been used for soil vapor sample collection, including Summa™ canisters, Tedlar® bags, Cali-5-Bond® bags, syringes, and sorbent sampling tubes, at Chevron sites, **Summa™ canisters (Figure 6) are required for soil vapor samples, for they provide samples with the highest possible integrity when collected using the appropriate sampling protocol.** Tedlar® bags are not recommended, primarily because of the concerns about integrity of soil vapor samples beyond a holding time of 48 hours as well as presence of trace levels of VOCs in new Tedlar bags (Hartman, 2006). Soil vapor samples can be collected in syringes for on-site soil vapor analyses *only* where the sample is immediately injected into a gas chromatograph (GC).

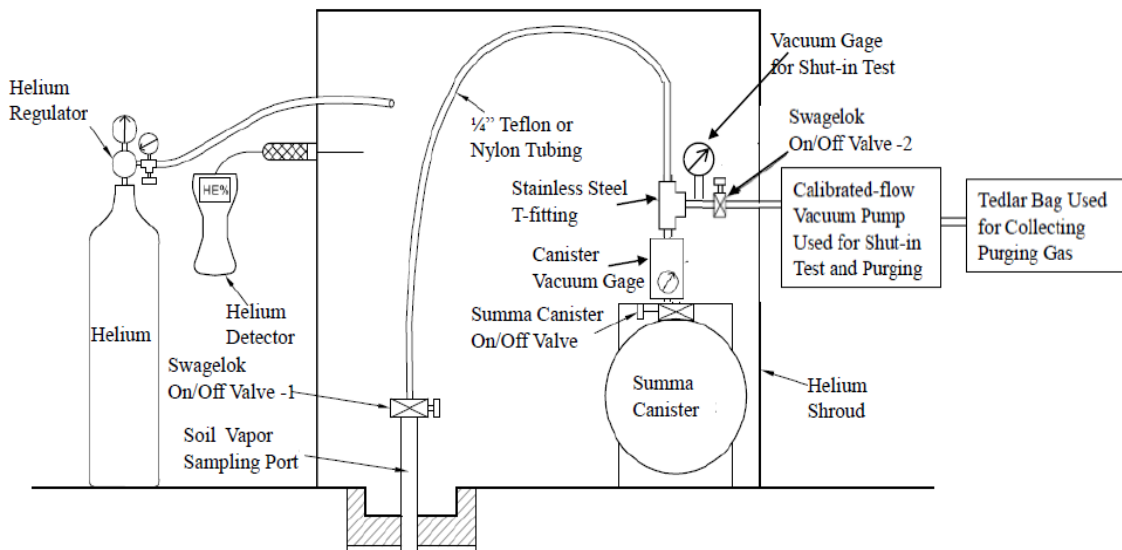

Figure 5. Picture of a sampling system for soil gas sampling train leak test, soil gas purging and sampling (Adapted from ARCADIS)

A Summa™ canister is a stainless steel, gas-tight, opaque and laboratory-certified clean sample container with a passivated internal surface. The passivation process utilizes electro polishing and chemical deactivation to create a chemically inert surface. Containers range in size from < 1 L to 15 L and are provided by the analytical laboratory. Canisters are typically certified clean at the 10 % level (i.e. every one out of 10 canisters is certified after cleaning) or at the 100 % level (i.e. every canister is certified after cleaning). The cleaning process is the same for both certification levels and utilizes dilution, heat, and high vacuum. The certification process utilizes EPA Method TO-15 (GC/MS) to ensure that VOC concentrations are <1 ppb_v. **It is acceptable to use canisters certified at the 10% level for soil vapor sampling activities. However, the use of 100 % certified canisters is required for sub-slab soil vapor, indoor air and ambient air sampling in order to minimize potential interferences in analyzing low**



VOC concentrations for human health risk assessment. The required size of the canister depends upon the laboratory's capabilities. **Before ordering canisters, contact the laboratory to inquire about what size canisters are required to meet the reporting levels necessary to meet site data quality objectives.**

After cleaning, the canister is evacuated until a vacuum of 29.9 in Hg is obtained. The canister will hold a vacuum of greater than 25 in Hg for more than 30 days. The maximum holding time for canisters following sample collection varies from state to state. Check the locally applicable regulations to determine the maximum holding time for the site in question. As discussed below, the soil vapor sample flows into the canister due to the pressure gradient between the vadose zone and the canister. A flow controller/particulate filter, provided by the laboratory, controls the vapor flow rate into the canister. Be aware that the flow controller may be defective and it is best practice to have some extra available.



Figure 6. 6 L Summa™ canister with 1/4" stainless steel bellows valve (image from Air Toxics Ltd.)

Regardless of the design of the sampling equipment, there are a number of important topics to address in order to obtain reliable soil vapor concentration data. These topics are discussed below.

3.2 Field Activities Prior to Sampling/Documentation

Written documentation of field conditions during sampling is required. This includes weather conditions (temperature, barometric pressure, wind direction and speed, humidity, degree of cloud cover); surface soil conditions (presence of standing water, wet soil, irrigation activities, etc.) and groundwater elevations. Some agencies are concerned that the rain will affect the validity of the sample (> 0.5 inch precipitation during 24-hour period as in California EPA, 2012). Under wet soil conditions, one should follow the state soil vapor sampling guidance for detailed requirements on soil gas sampling or consult with Chevron project manager if no such state guidance exists. Maintain detailed



field records of all activities, conditions, and sampling processes, including names of field personnel, dates and times, etc. It is important to maintain consistency in sampling activities between sampling events (e.g., purging volume and purge rate, sampling volume, leak testing methods, equipment used). Carefully plan all sampling activities to maintain consistency between sampling events and to avoid errors that can affect soil vapor concentrations.

3.3 Equilibration Time

The installation of soil vapor sampling probes can introduce oxygen into anaerobic portions of the vadose zone. An equilibration time is required to account for the effects of soil vapor probe installation; this allows for equilibration of vapor component concentrations between the probe and subsurface (API 2005). Soil vapor samples should not be obtained until after the equilibration time is reached. **Probes installed using hollow stem or hand auger methods should be allowed at least 48 hours of equilibration time while probes installed using direct-push techniques should be allowed at least two hours of equilibrium time (California EPA, 2012).**

3.4 Evaluating Leaks in Sampling Train

Leakage of atmospheric air into the sampling equipment during sampling can compromise sample integrity and dilute measured soil vapor hydrocarbon concentrations, possibly to the point of an incorrect decision such as failing to identify a concentration of concern (i.e., a “false negative”). Contaminants in ambient air can also enter the sampling system and be interpreted as originating from diffusive transport from a subsurface source (i.e., a “false positive”). Air leakage can occur at the land surface into the probe and, more typically, through loose fittings in the above-ground sampling equipment.

Leakage of air into the below-ground sampling system is unlikely if the probe has been properly constructed and a proper bentonite or concrete surface seal (described earlier) has been emplaced. Temporary (direct-push) probes are most susceptible to leakage around the rods. Sub-slab soil vapor sampling probes also are susceptible to leakage of indoor air due to the difficulties of ensuring a proper seal between stainless steel probe and slab concrete. Sampling equipment must be thoroughly inspected to ensure tight fittings between all components. Be aware that leakage locations may not be obvious. Elevated O₂ concentrations in samples from deeper depths in multi-level probes may be indicative of leakage, but in some cases this alone would not provide definitive evidence for leakage. If O₂ concentrations remain high with increasing depth and petroleum hydrocarbon concentrations are also high, this is evidence that leakage is likely to be occurring. **To minimize the potential for leakage, the soil vapor sampling rate should be kept at < 200 mL/min per EPA guidance (Section 3.6).** Repair or replacement of the sampling probe may be necessary if it is determined that leakage through the probe is occurring. Refer to state or regional guidance to determine if a prescribed course of action applies for probe replacement.



After the soil vapor sampling ports and probes are constructed and installed and soil vapor has equilibrated, leaks in the sampling train should be tested, including a complete shut-in test and system leak test.

3.4.1 Shut-in Test

After the soil vapor probe construction, soil vapor sampling probe installation, and sufficient time for the soil vapor to reach equilibrium, a shut-in test should be conducted to check for leaks in the above-ground sampling system. The equipment set-up for shut-in test is also shown in Figure 5. In this case, the helium shroud and the Tedlar bag may not be needed. To conduct a shut-in test, assemble the above-ground valves, lines and fittings downstream from the top of the probe as shown in Figure 5. The Swagelok valve-1 and Summa Canister valve are kept closed, evacuate the system to a minimum measured vacuum of about 100 inches of water using a purge pump and close Swagelok valve-2. Observe the vacuum gauge connected to the system with a “T”-fitting for at least one minute or longer. If there is any observable loss of vacuum, adjust the fittings until the vacuum in the sample train does not noticeably dissipate. After the shut-in test is validated, the sampling train should not be altered. The vacuum gauge should be calibrated and sensitive enough to indicate a water pressure change of 0.5 inches. If the shut-in test failed, then specific measures are needed such as tightening all the fittings and repeating the test until it is validated before proceeding to the next test.

3.4.2 Leak Test

3.4.2.1 *Leak test tracer*

A tracer is used to test for an ambient air leakage into the sampling system. Numerous tracer compounds have been referenced in regulatory and industry guidance documents, including isopropanol, isobutene, propane, butane, helium, and sulphur hexafluoride. **Chevron does not recommend use of isopropanol** because, due to its high vapor pressure, even a small leak will result in laboratory dilutions that will compromise the data quality objectives (i.e. reporting limits higher than screening levels). **Chevron does not recommend use of isobutene, propane, or butane** as leak detection tracers because their purity cannot be easily verified, resulting in a likelihood of low level impurities such as BTEX compounds. **Chevron does not recommend use of sulphur hexafluoride** because it has a very high greenhouse gas potential, and therefore difficult to acquire and use as a tracer compound. **Chevron does not recommend use of Freon** because it is not possible to determine the degree of leakage that has taken place and there is a possibility that Freon is present in the soil gas due to ubiquitous use of Freon as coolant for air conditioning units. **Chevron recommends use of laboratory grade helium as a leak detection tracer gas where practical to do so, based on accessibility.** Helium is readily available, has low toxicity, does not disrupt analytical measurements, will not be found at fuel contaminated sites, and has a high purity. Small volume bottles of helium can be purchased at party stores but contain industrial grade helium, which may contain organic compounds as impurities. **Lab grade helium is recommended**, and will require time for the sampling crew to acquire through the analytical laboratory or an alternate source. A possible drawback of helium is that its small molecular size may cause it to permeate the sampling materials more readily than larger VOC molecules (Hartman, 2006). Of all the



tracer compounds described in various regulatory guidance documents, only the leak detection method using helium gas provides a quantitative estimate of leakage rate. **If lab-grade helium supply is scarce (as has been recently reported), Chevron recommends using 1,1-difluoroethane (1,1-DFA) as an alternative leak tracer gas, with prior concurrence from EMC project manager and ETC.**

Small amounts of sample train leakage may be permissible, subject to regulatory standards and analytical limits applicable to the site. **For sites located in California, Chevron follows the CAEPA guidance (CAEPA, 2012) and recommends a maximum leak percentage of 5% be used to determine sample validity. For sites located outside California, Chevron recommends a maximum leak percentage of 10% be used to determine sample validity.** This is consistent with the VI guidance in New Jersey (NJDEP 2012). The presence of any leakage should be recorded, as should all techniques used in the leak testing process. Maintain consistency of the leak testing process over multiple sampling events.

Where multi-level soil vapor probes are intended to acquire soil vapor concentrations to be used either as a basis for an attenuation factor screening step, or as a source term for Johnson & Ettinger modeling, leakage of as much as 10% may allow back calculation of an adjusted soil vapor concentration. However, this may not be possible if the overall compounds of interest concentrations are low, and the reporting limits have been increased above acceptable screening values due to the necessity to dilute the sample to avoid loading the GC column with tracer gas. In such cases, the probes must be re-sampled.

3.4.2.2 Leak test using helium as a tracer

The New York State Department of Health (NYSDOH, 2006) has prepared guidance for using helium as a tracer gas, suggests construction of a shroud around the sampling probe but not the sampling train. To test the integrity of the whole sampling train, **Chevron recommends building a shroud to cover the entire sampling train (probe to Summa canister) in order to detect possible leaks in all fittings and tubing of the sampling system (Figure 5 and Figure 7).** This enables detection of helium ingress into the sampling train and can be used to estimate the leakage rate as shown at the end of this section. The shroud should be filled with helium before purging the sampling point. It is important to ensure that the pressure in the shroud is close to atmospheric pressure, so that normal sampling conditions exist (NYSDOH, 2006). **Introducing helium from a pressurized cylinder for several seconds will generally be sufficient to create concentrations in the shroud up to 10% by volume or higher. The helium concentration in the shroud should be monitored and maintained relatively stable at the target concentration, i.e. 10% or higher (CAEPA, 2012) during the course of soil vapor sampling.** This can be done with a helium detector connected to a port on the shroud. Portable detectors are available for rental. It is required that the selected portable detector have a minimum helium detection limit of 0.5% by volume.



The following guidance on constructing the helium shroud is adapted from the EPRI Reference Handbook for Site-Specific Assessment of Subsurface Vapor Intrusion to Indoor Air (EPRI, 2005). The shroud can be in the form of a clear plastic container (e.g. large Tupperware™ or Rubbermaid® container) or a tent made of clear plastic sheet large enough to surround the soil vapor probe and valves and fittings at the top of the probe as in Figure 5 and Figure 7. The shroud will typically have three ports, one for helium addition, one port for monitoring helium concentration inside the shroud and another port for the ¼-inch Nylon tubing coming out of the shroud for the vacuum pump located outside the shroud.

Chevron recommends using one Summa canister under a helium shroud for leak-test (helium checking in the soil gas sample) and soil vapor sampling (chemical analysis in the soil vapor sample) simultaneously. A separate Summa Canister is not needed for leak-test. Figure 5 illustrates conducting a simultaneous leak-test and soil vapor sampling from a sub-slab soil vapor sampling point. In this case, the Tedlar bag may not be needed and the Swagelok valve 2 remains closed. Turn on the Summa canister valve to collect a soil vapor sample for analysis of helium and chemicals in the lab. To access the sampling train, the shroud can be lifted and the canister valves opened. The shroud can then be placed back again on the ground/floor and filled with helium within a half-minute or less. The samples typically take at least 5 minutes to fill, so the first few seconds of no helium in the shroud is not problematic as long as the helium concentration in the shroud is maintained relatively stable at the target concentration.

The analytical laboratory should be notified that helium is to be used as a leak detection tracer prior to sampling. The integrity of the soil vapor samples can be assessed by estimating the % leakage as follows.

$$\%leakage = \frac{\text{helium concentration in the soil vapor sample (ug/m}^3\text{)}}{\text{average helium concentration measured inside the shroud (ug/m}^3\text{)}} \times 100$$

3.5 Purging

The US EPA conducted a comparison of chlorinated hydrocarbon soil vapor concentrations collected utilizing a broad range of purge volumes (0.5 to 100L) at a site with relatively coarse-grained soils and found no significant differences based on the purge volumes (DiGiulio et al 2006b). McAlary and Creamer (2006) performed similar experiments at a Chevron research site for high concentration petroleum hydrocarbon vapors and also observed no effect in sample concentration as a function of purge volume. While it is not clear to what degree purging may affect sample concentration, all regulatory guidance requires stagnant air in the sampling tubes be removed prior to sample collection. This is believed to ensure that the soil vapor sample is representative of actual soil vapor concentrations.

Field notes containing information about the above-ground sampling equipment and below-ground tubing length and inner diameter should be used to calculate the “dead



volume” to be purged. The “dead volume” should also include the borehole sand pack. The volume of a sample container, such as a Summa™ canister (which is not used during purging), should not be included in this calculation. **Check to make sure that all connections, fittings, etc. are tightly fit in the sampling equipment prior to purging.**



Figure 7. Helium shroud used for leak-testing soil vapor sampling train.

Figure 5 also shows the equipment set-up recommended by Chevron when purging a soil vapor sampling port. In some cases, the regulatory agency requires one to develop the number of purging volumes. In that case, as shown in Figure 5, a battery powered, flow-calibrated pump and a Tedlar bag can be used to purge the system and determine the number of required purge volumes. The purging gas collected by the Tedlar bag is analyzed on site for chemical concentrations till the concentrations become stabilized. From the volume of gas purged which is measured by the flow-calibrated pump, the number of purging volume can be determined and recorded and then the soil vapor sampling can proceed. If the number of purging volumes is not required, Tedlar bag only serves as a collector of purging gas to protect the environment from potential adverse impact from the contaminants in the soil vapor.

The maximum flow rate for purging should not exceed the flow rate limit used for subsequent sampling (< 200 mL/min). Guidance documents from different agencies recommend different purge volumes, ranging from 1 to 10 purge volumes (CSDDEH, 2002; API, 2004, CAEPA, 2012). **Chevron recommends that 3 volumes be purged unless otherwise required by applicable guidance.** The purge test data (calculated purge volume, purging rate, and duration of purging) should be recorded for each soil vapor sampling point. It is important to ensure that the same purge volumes and rates are used at a given probe for each sampling event.

For fine-grained soils large sample volumes are often not possible or difficult to collect. Also, if large sample volumes are attempted, the chances of leakage in the sampling train increase. A larger sample volume also increases the uncertainty about the location of soil vapor sampled. Given these uncertainties, it is best to minimize the “dead volume” that needs to be purged in the sampling train.



3.6 Sample collection

There are numerous combinations of tubing, connectors, pumps, and sampling containers that have been used for soil vapor sample collection. As noted above, the design of the sampling equipment should be such that the dead volume is minimized in order to keep the necessary purge volume small. In all cases, a vacuum is used to draw soil vapor from the subsurface to the sample container. Note that equipment must be decontaminated prior to sampling, shut-in test should be performed before purging and sampling, and leak-testing should be performed during the sampling process. An example of the equipment arrangement used for soil vapor purging (with a flow-calibrated pump) and sampling (with Summa™ canister) is shown previously in Figure 5. In Figure 5, to collect a sample, Swagelok valve 1 and the Summa canister valve should be open and Swagelok valve 2 should be closed. The soil vapor sample collected will be analyzed for helium (for leak test), COCs and fixed gases.

The exact procedure used in obtaining a soil vapor sample will vary as a function of the equipment used, but the following considerations are important to ensure that a high quality sample is collected.

3.6.1 Vacuum And Flow Rate Considerations

The vacuum and resulting sampling flow rate should be minimized in order to limit enhanced volatilization of VOCs from water and soil into the soil vapor sample. Consistency in vacuum and sample flow rates should be maintained between sampling probes and over multiple sampling events. The vacuum and flow rate should be documented in the field notes. A flow rate between 100 ml/min and 200 ml/min and a vacuum less than 100 inches of water (approx. 7.3 in Hg at 4°C) should be maintained during purging and sampling (California EPA, 2012).

The Summa™ canister system utilizes a flow controller to control the flow rate. The flow controller contains a critical orifice flow restrictor intended to maintain a relatively constant flow rate over a 0.5 to 8 hour period, even though the vacuum in the canister is decreasing over that time (which would otherwise cause the flow rate to concurrently decrease). A vacuum gauge is built in to the flow controller to monitor sampling progress. The laboratory (e.g., Eurofins Air Toxics Inc.) sets up the flow controller for the flow rate specified. Table 2 shows the range of flow rates for given sampling time intervals. A particulate filter is built into the flow controller device which serves to prevent particulates from fouling the flow controller or entering the Summa™ canister. The recommended sampling time interval for soil vapor samples is approximately 30 minutes, but in any case the flow rate should not exceed 200 mL/min.

Sampling Interval (hrs)	0.5	1	2	4	8	12	24
6 L Canister	167	83.3	41.7	20.8	11.5	7.6	3.5
1 L Canister	26.6	13.3	6.7				

Table 2. Flow rates (mL/min) for given sampling time intervals using the flow controller (from Eurofins Air Toxics Inc.)



3.6.2 Other Sampling Considerations

Once the above listed topics have been addressed, after making certain that all connections between the Summa™ canister, flow controller, and all other portions of the sampling equipment are tight, and arrangements have been made with the analytical laboratory regarding sample shipment and analysis, soil vapor sampling can commence. Sampling of all probes should preferably be completed within a one day time period, with a maximum collection period of one week. Sample collection from a purged soil vapor probe should begin as soon as possible once purging is completed. Leak-testing should be performed concurrently with sampling as described above. To begin sampling, open the valve on the Summa™ canister. As the canister fills, observe the vacuum gauge on the flow controller to ensure that the vacuum in the canister is decreasing over time. If the flow controller is working correctly, the planned sampling completion time will be reached when the canister vacuum has decreased to 5 in Hg. Note that low permeability soils characterized by low soil vapor flow rates may require sampling to cease before the canister vacuum has decreased to 5 in Hg.

Quality control (QC) of soil vapor samples must be addressed through the collection of equipment blanks and field duplicates. An equipment blank should be collected at the site during sampling activities by collecting a sample of clean air or nitrogen through the probe materials before installation in the ground. Analysis of the equipment blank can provide information on the cleanliness of new materials and/or the effectiveness of decontamination procedures used in the field. Clean stainless steel, Nylon or Teflon® tubing and a certified regulator should be used. Only 100% certified canisters (the sample canister and the source canister/cylinder, if applicable) should be used to collect equipment blank. **Trip blanks were previously recommended, however with the use of 100% certified Summa™ canisters, trip blanks are not necessary.**

At least one duplicate sample should be obtained each day of sampling, or from at least 10 % of the samples obtained. A duplicate sample should be collected by using a splitter (such as a T fitting) located between the flow controller and sample canisters, with separate sampling tubes connecting the splitter to two Summa™ canisters as shown in Figure 8. The flow controller must be set such that the flow rate from the sampling probe is < 200 mL/min; this will double the required sampling time since two canisters are being filled simultaneously.

After sample collection, canisters must not be chilled since contaminants may condense in the canister at low temperatures. Make certain that all samples are correctly and clearly labeled. Follow standard chain-of-custody procedures, including noting the final canister vacuum and serial numbers of the canisters and flow controllers. The laboratory checks the vacuum on receipt to ensure that there were no leaks during shipment. See Section 3.1 for canister maximum holding time information. Document all procedures, sampling times, conditions, problems, etc

If the initial assessment of subsurface soil vapors indicates potential for vapor intrusion to indoor air, further characterization will usually require entry into the affected building(s)



to conduct sub-slab vapor sampling and concurrent indoor and ambient outdoor air sampling as described in the following sections. EMC environmental attorneys will be able to help in getting the necessary access agreements before these sampling activities commence.

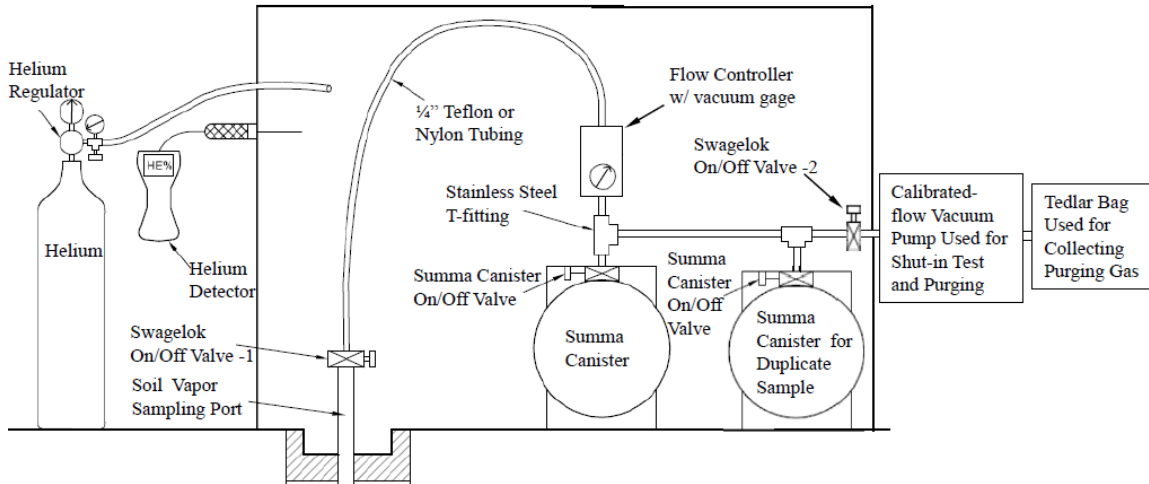

Figure 8. Soil vapor sampling train using two Summa canisters for a sample and a duplicate sample (Adapted from ENSR)

4 SUB-SLAB VAPOR SAMPLING

4.1 Sub-slab soil vapor probe installation

Sub-slab vapor sampling probes allow for collection of soil vapor data from directly beneath the slab from a layer of granular fill material that is highly permeable and well-drained for structural purposes. These samples are useful to evaluate a possible relationship to indoor air samples and are recommended if indoor sampling is deemed necessary. It is critical to obtain building construction details as much as possible (i.e., slab thickness, depth and type, presence of vapor barrier, location of utility trenching etc) to appropriately locate sub-slab vapor sampling locations. **Sub-slab sampling may not be possible when groundwater or a partially saturated capillary fringe is present directly below the slab.** Do not drill through the slab if it is suspected that the penetration could allow groundwater to enter the building during high water table conditions. Also, it is important to determine prior to drilling if the slab has a vapor barrier; if so, **make sure the vapor barrier is not punctuated during the drilling.** **Drilling through tension slabs is not recommended.** Tension slabs contain embedded steel cables that have been pulled tight after the concrete has cured. The tension in the cables strengthens the slab and helps prevent cracking. The slab can be damaged if a cable is cut during drilling.

Petroleum hydrocarbons are amenable to aerobic biodegradation. Therefore, a conservative approach supports obtaining soil vapor samples at the center of the slab where lowest oxygen concentrations in soil are likely to occur (California EPA 2011) and away from utility conduits,. **At least two probes should be placed, for foundation area**



up to 5000 ft² with one located in the center of the slab, and the other in the likely direction of potential subsurface impacts, (California EPA, 2005, 2011). US EPA recommends several probes for single-family dwellings to assess spatial variability (e.g., 3 to 5; DiGiulio, 2006a).

Prior to drilling holes in a slab, identify and mark utilities coming into the building from the outside (e.g., gas, water, sewer, electrical lines) and determine any internal locations where utilities penetrate the slab (e.g., furnace, water heater, circuit breaker box, water or sewer lines). **Avoid installing sub-slab monitoring points where the utilities penetrate the slab as these may be potential entry points for downward oxygen migration through the slab. Also, avoid installing sub-slab points along straight-line points where utility trenches may have been installed beneath the slab during building construction.**

Prior to fabrication of sub-slab vapor probes, remove carpeting from the drilling location, if present. This can be done by cutting a small ½ inch square flap that can be glued back down after the probe is installed. Obtain any available information (e.g., from the owner, construction plans) to determine the thickness of the slab. **Do not drill a pilot hole to assess the thickness of a slab.** As illustrated in Figure 9, use a rotary hammer drill to create a “shallow” (e.g., 2.5 cm or 1 inch deep) “outer” hole (e.g., 2.2 cm or 7/8 inch diameter) that partially penetrates the slab. Do not completely penetrate the slab with the shallow hole. Use a small portable vacuum cleaner to remove cuttings from the hole. Removal of cuttings in this manner in a non-penetrated slab will not compromise soil vapor samples because of lack of pneumatic communication between sub-slab material and the vacuum cleaner.

Next, use the rotary hammer drill to create a smaller diameter “inner” hole (e.g., 0.8 cm or 5/16 inch diameter) through the remainder of the slab and some depth (e.g., 7 to 8 cm or 3 inch) into sub-slab material. Drilling into sub-slab material will create an open cavity which will prevent obstruction of probes by small pieces of gravel.

The basic design of a sub-slab vapor probe is illustrated in Figure 10. Once the thickness of the slab is known, tubing should be cut to ensure that the probe tubing does not reach the bottom of the hole (to avoid obstruction of the probe with sub-slab material). **Chevron prefer use of stainless steel tubing materials although recent data comparing the performance of Teflon[®] and Nylon tubing with stainless steel tubing suggest that it would be appropriate to use these materials for constructing the sub-slab vapor probes too (Hartman 2008).** An advantage in using Nylon and Teflon[®] tubing is that there will likely be fewer sealing difficulties between the probe and concrete. If using stainless steel, construct sub-slab vapor probes from small diameter (e.g., 0.64 cm or ¼ inch outer diameter (OD) x 0.46 cm or 0.18 inch inner diameter (ID)) chromatography grade 316 stainless steel tubing and stainless-steel compression to thread fittings (e.g., 0.64 cm or ¼ inch OD x 0.32 cm or ⅛ inch (ID) Swagelok[®] or NPT female thread connectors) as illustrated in Figure 10. **Use stainless-steel to ensure that construction materials are not a source of VOCs.** Brass fittings (tubing, nipples and



couplings) readily available at hardware stores are machined using cutting oils and could be a potential source of trace level VOCs and as such are not recommended to be used for constructing sub-slab vapor probes. In addition, use of Teflon[®] tape is recommended on any NPT threaded joints to ensure a good seal and to reduce the torque needed install and remove the probe plug, thus reducing the stress on the cement bond.

Set the sub-slab vapor probe in the hole. As illustrated in Figure 10, the top of the probe should be completed flush with the slab and have recessed stainless steel plugs so as not interfere with day-to-day use of the building. **The seal between the stainless steel sub-slab probe and the concrete floor is a common source of leakage.** Modeling clay or cement is typically used for surface seals. Unfortunately, there are few sealants that are non-adsorptive, do not give off vapors, and adhere well to both concrete and metal surfaces. Hydrating (swelling) cement adheres reasonably well to concrete, but not as well to metal tubing, so it is not unusual for the tubing to spin while fittings are being attached. Attaching all fittings before the probe is installed may minimize stresses on the seal. Mix a quick-drying Portland cement which is “VOC free” with water (e.g. hydro-cement available at building supply stores) which expands upon drying to ensure a tight seal) to form a slurry, Inject or push the slurry into the annular space between the probe and outside of the “outer” hole. Allow the cement to cure for at least 24 hours prior to sampling.

4.2 Sub-slab soil vapor sampling train tests, purging and sampling

After sub-slab soil vapor sampling probes are installed and soil vapor reaches equilibrium, a shut-in test should be done before purging and sampling. The procedures of shut-in test and leak test while sampling are the same as described in section 3 and as shown in Figure 5 and Figure 7.

After shut-in test, the probe is ready for purging and sampling. Please refer to section 3 for procedures of purging and sampling. **For sub-slab soil vapor sampling, 1 L 100 % certified Summa[™] canisters are preferred in order to minimize the volume of soil vapor collected.** Collecting a smaller sub-slab sample will minimize the duration of inconvenience to the building occupants by minimizing the amount of time the helium shroud has to be monitored.

5 INDOOR AND AMBIENT (OUTDOOR) AIR SAMPLING

In some situations, it may be necessary to conduct indoor air and ambient air sampling to assess the potential for vapor intrusion to indoor air from subsurface contamination. **It is recommended to collect these concurrently with the sub-slab soil vapor samples.** Indoor air samples may contain BTEX and other VOCs within the concentration ranges commonly seen as background values measured at sites where no subsurface petroleum hydrocarbon contamination is known to be present. Unfortunately, these background VOC concentrations are also within (or even greater than) the range of risk-based concentrations (RBC) assuming a cancer risk range of 1E-06 to 1E-04 or hazard quotient of 1 (Figure 11, from Dawson & McAlary, 2009). There are many sources of background contamination inside buildings. Materials and substances commonly found



in commercial and residential settings, such as paints, paint thinners, gasoline-powered machinery, building materials, cleaning products, dry cleaned clothing, and cigarette smoke, can potentially contribute to VOC detections in indoor air testing. Table 3 shows a list of common household petroleum – related VOC sources (NJDEP 2005). In urban areas, outdoor air also often contains background concentrations of VOCs that exceed



Figure 9. (a)Drilling through a slab, and (b) inner and outer holes (EPA).

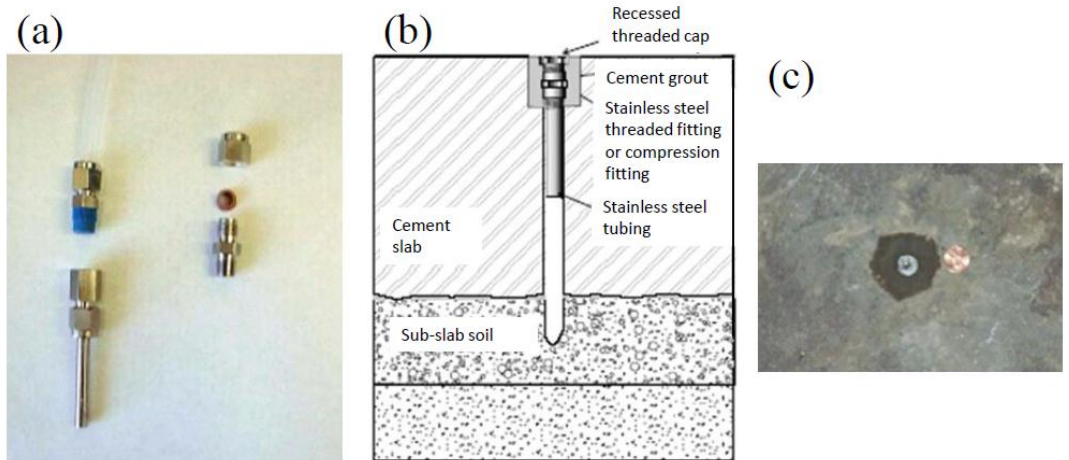

Figure 10. (a) Stainless steel sub-slab vapor probe components; (b) general schematic of sub-slab vapor probe and (c) completed sub-slab vapor probe. (EPA)

risk-based indoor air target levels. **Therefore, outdoor ambient air samples should be collected whenever indoor air samples are collected to characterize the contribution from outdoor air.** It is not recommended to collect indoor air samples from buildings outside the assessed footprint of VOCs in the subsurface in an attempt to characterize the contribution from indoor sources, because consumer products, building materials and occupant habits vary from building to building.



5.1 Indoor Air Sampling

Given the multitude of sources for VOCs in indoor air and that for some VOCs, the background indoor air concentrations could exceed the risk-based concentrations, it is critical to carefully plan any sampling event. Specifically for benzene in urban environments, indoor air sampling is not considered to be a first choice assessment option for residential structures unless the State has raised the acceptable indoor air benzene values above ambient levels. **This toolkit makes recommendations on the key elements of the plan. The project team should also consult appropriate state guidance for detailed information on indoor air sampling strategies, building inspection/surveys and household products inventory forms** (e.g., NYSDOH 2005, 2006, MADEP 2002, California EPA 2011, ITRC 2007).

Indoor air sampling may require multiple visits to the subject building(s). A pre-sampling site visit should be arranged at least 24 hours in advance of the sampling (NYSDOH 2005, MADEP 2002, California EPA 2011). This is used to interview the occupants and doing a building survey to gather the following information.

- Contact information for the occupants and owner
- Type of building construction
- Foundation characteristics
- Heating, Ventilating and Air Conditioning (HVAC) system details
- Water wells and sewage disposal

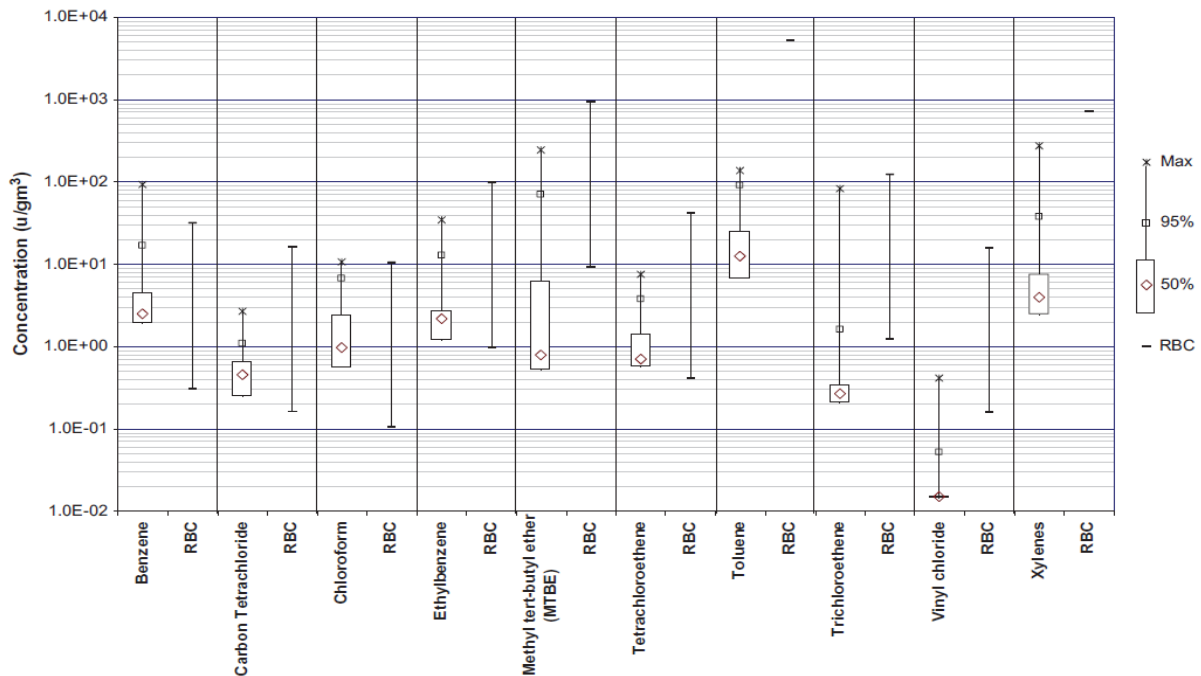

Figure 11. VOC concentrations in background indoor air compared to RBC.



- Potential indoor sources of VOC vapors, particularly those containing hydrocarbons, such as fuels, combustion products, cleaners, solvents and lubricants containing petroleum distillates and tobacco products. It is advisable to remove consumer products that contain VOCs or SVOCs from the building and any attached garage or shed at the time of the pre-sampling survey. Any unavoidable exceptions should be documented (including appropriate photographs) and highlighted with the results of the indoor air analysis.
- Plan view showing the sampling location(s) and pertinent information on floor layout including chemical storage areas, garages, doorways, stairways, basement sumps, plumbing and electrical conduits, elevator shafts etc.
- Potential outdoor sources of VOCs in ambient outdoor air. This will include a diagram of the area surrounding the building(s) being sampled showing potential sources such as service stations, repair shops, retail shops, landfills etc.

Indoor air sampling should be done in an environment that is representative of normal building use. Heating and air conditioning systems should be operated normally for the season and time of day. **Use 6 L 100% certified Summa™ canisters placed in the center of the room on the lowest floor at 3 to 5 ft above floor level to provide a sample representative of the breathing zone.** In order to mimic the anticipated daily exposure by inhalation, the **sampling duration for commercial/industrial buildings is 8 hours and for residential building is 24 hours (California EPA 2011).** Upon deployment of the sampling equipment, the Building Survey Form is updated to include the location of the sampling equipment, time, date, identification number, and environmental conditions.

As far as possible, the following activities should be avoided during the indoor air sampling event. Any unavoidable exceptions should be documented and highlighted with the results of the indoor air analysis:

- Allowing containers of gasoline or oil within the building or garage area, except for heating fuel oil tanks.
- Cleaning, waxing or polishing of furniture or floors (if cleaning is needed, use water only).
- Smoking cigars, cigarettes or pipes.
- Using air fresheners or odor eliminators.
- Using materials containing VOCs (dry markers, white out, glues, etc.).
- Using cosmetics including hairspray, nail polish, nail polish removers, perfume, and cologne.
- Applying pesticides.

5.2 Outdoor Ambient Air Sampling

Chevron recommends collecting ambient air samples at the same time the indoor air samples are collected. This will provide information about outside influences on indoor air quality. The outdoor ambient air sample will identify vapors from automotive fuels and exhaust, point sources such as gasoline stations, stack emissions and possible unique situations (paving crews, forest fires etc). **Use 6 L 100% certified Summa canisters**



placed 3-5 ft above grade at an upwind location protected from the elements (wind, rain, snow or ice) on the upwind side of the building (5-15 ft away). It is recommended that ambient air sampling begin at least 1 hour prior to indoor air sampling and should continue at least 30 minutes prior to the end of the indoor air sampling period.

6 ANALYTICAL TECHNIQUES

The analytical methods used are specific to the components analyzed and the reporting limits required to meet the data quality objectives. For example, reporting limits for fixed gases such as O₂, CO₂, N₂, and CH₄ of about 1% v/v are sufficient for interpretation; whereas VOCs such as benzene often have target concentrations in the low µg/m³ range or lower, although this varies considerably between States. **Analytical reporting limits for indoor air samples should be lower than the risk-based target indoor air concentration, unless it is technically impracticable.** Analytical reporting limits for soil vapor samples could be higher because soil vapor concentrations attenuate upon entry to indoor air to varying degree. These could be estimated as a ratio of the indoor air target concentration to a conservative attenuation factor for the location of soil vapor sample (e.g., 1 for crawl space, 0.05 for sub-slab vapor and 0.002 for a deeper soil vapor sample in CAEPA 2011 VI guidance). Confer with the laboratory and applicable guidance to ensure that the necessary detection limits are met.

Before sampling and analysis begins, refer to applicable state and/or regional guidance and regulations to ensure that all requirements are complied with in sampling and analysis, including the number of analytes, analytical methods, reporting limits, and any requirement for state certification of the analytical laboratory. Maintain consistency of analytical methods between sampling events, as this can help reduce uncertainties in data results and interpretation. Table 4 provides a summary of required analytes for different samples and recommended analytical methods used for several common analytes during vapor intrusion investigations (adapted from API 2005).

Prior to sampling and analysis, the specific chemical components of concern at the site should be identified. These components commonly consist of the VOCs and SVOCs that have been identified as chemicals of interest at the site. In addition, some regulatory agencies have specified which chemicals of interest must be included in the list of analytes.

Prior to analysis, it is important to verify that a calibration for the chemicals of interest, or at a minimum calibration for the classes of chemicals of interest, has been developed. The mass spectrometer (MS) yields different response factors for different classes of compounds. **The tracer compound (helium) used during leak testing should also be included in the list of laboratory analyses for soil vapor samples. A laboratory-modified version of ASTM method D1946 may be needed because helium is not listed as an analyte in the method.** The analytical method used should be capable of quantifying these components at a concentration such that the subsurface vapor to indoor air exposure pathway can be adequately evaluated.



Chemical	Common Household Sources
Acetone	Rubber cement, cleaning fluids, scented candles and nail polish remover
Benzene	Automobile exhaust, gasoline, cigarette smoke, scented candles, scatter rugs and carpet glue
1,3-Butadiene	Automobile exhaust and residential wood combustion
2-Butanone (MEK)	Automobile exhaust, printing inks, fragrance/flavoring agent in candy and perfume, paint, glue, cleaning agents and cigarette smoke
Ethylbenzene	Paint, paint thinners, insecticides, wood office furniture, scented candles and gasoline
Formaldehyde	Building materials (particle board), furniture, insulation and cigarette smoke
n-Heptane	Gasoline, nail polishes, wood office furniture and petroleum products
n-Hexane	Gasoline, rubber cement, typing correction fluid and aerosols in perfumes
Methyl isobutyl ketone (MIBK)	Paints, varnishes, dry cleaning preparations, naturally found in oranges, grapes and vinegar
Methyl tert butyl ether (MTBE)	Gasoline (oxygenating agent)
Naphthalene	Cigarette smoke, automobile exhaust, residential wood combustion, insecticides and moth balls
Styrene	Cigarette smoke, automobile exhaust, fiberglass, rubber and epoxy adhesives, occurs naturally in various fruits, vegetables, nuts and meats
Tertiary butyl alcohol (TBA)	Gasoline (oxygenating agent)
Toluene	Gasoline, automobile exhaust, polishes, nail polish, synthetic fragrances, paint, scented candles, paint thinner, adhesives and cigarette smoke
1, 2, 4-Trimethylbenzene	Gasoline and automobile exhaust
1, 3, 5-Trimethylbenzene	Gasoline and automobile exhaust
2,2, 4-Trimethylpentane	Gasoline and automobile exhaust
Xylenes, total	Water sealer, gasoline, automobile exhaust, markers, paint, floor polish and cigarette smoke

Table 3 Common household sources of petroleum hydrocarbons in background indoor air (Adapted from NJDEP, 2005)



6.1 VOCs/SVOCs

Gas chromatography/mass spectrometer (GC/MS) methods are recommended for all VOC and SVOC analyses. In the past we have recommended using EPA method TO-15 for analyzing VOC and SVOC concentrations in all types of VI investigations, however, a number of studies (Hayes et al 2005, Picker 2005 and Digiulio et al 2006a) have compared analytical results using methods TO-15 and 8260B. These data indicate that both give equivalent results down to levels as low as 10 µg/m³. TO methods and hardware are designed for measuring low VOC levels in ambient air and not for high concentrations likely to be seen in soil vapor samples (which can exceed 100000 µg/m³). **It is recommended that method 8260B be used for analyzing soil vapor samples and TO-15 be used for analyzing sub-slab vapor, indoor air and outdoor ambient air samples.** High concentrations in soil vapor samples can lead to system carryover, large dilutions and contaminated Summa™ canisters increasing the potential for false positives, elevated reporting levels and problems associated with managing canisters (Hartman 2006).

Naphthalene must be analyzed in all cases, and when using TO-15 (for sub-slab vapor, indoor air or outdoor ambient air), the laboratory must be notified of this request prior to ordering the Summa™ canisters from the laboratory. In method

(a)

Sample Matrix	Indoor air	Outdoor air	Sub-slab soil vapor	Near-slab soil vapor
Analyte Required	All COCs no fixed gases	All COCs no fixed gases	All COCs and fixed gases	All COCs and fixed gases

(b)

Analytical Methods Recommended for Some Analytes		
Analytes	Field Method	Fixed Lab Method
BTEX	Method 8260	Method 8260 or TO-15
TPH	Method 8015	Method 8015 or TO-15
Naphthalene	N/A	TO-15 and/or TO-17
O ₂	Field meter w/ galvanic electrochemical cell (BP 1998)	EPA Method 3C or ASTM Method D1946
CO ₂	Field meter w/ Infrared analyzer (BP 1998)	
CH ₄	Field meter (CRWQCB)	
Helium	Field meter (Mark Model 9821 Helium Detector)	

Table 4 (a) Required analytes for different samples and (b) recommended analytical methods used for several common analytes (Adapted from API 2005).



TO-15 the detector (i.e. MS) can be operated in either the full scan mode (for standard method detection limit of 1 to 5 $\mu\text{g}/\text{m}^3$), or selected ion monitoring (SIM) mode to improve the method detection limit ($< 1 \mu\text{g}/\text{m}^3$) for a selected set of analytes. Sub-slab soil vapor samples should not be analyzed in the SIM mode for two reasons: One, it is not necessary as the risk-based soil vapor screening levels are generally higher than 5 $\mu\text{g}/\text{m}^3$ (Hartman 2006) and two, there is a potential for interference from the natural organic matter in the soil (EPRI 2005). **At this point, Chevron recommends using TO-15 method to do naphthalene sample collection and the lab conducting analysis should utilize certain procedures specified Appendix E in CAEPA's "Advisory Active Soil Gas Investigation" (CAEPA, 2012). Chevron does not recommend using TO-17 method due to the lack of the universal acceptance by most regulatory agencies.** Should the TO-17 method be required by the local agency, a detailed description of how soil vapor samples are to be collected in the field should be included with clear explanatory text and illustrative figures in work plan documents.

6.2 Fixed Gases

ASTM Method D1946, a gas chromatography/thermal conductivity detector (GC/TCD) method, is recommended for analysis of fixed gases, including O_2 and CO_2 . For CH_4 , ASTM Method D1946 can also be used, with a flame ionization detector (FID) in place of a TCD.

6.3 Data reporting

Soil vapor concentrations are reported in units of $\mu\text{g}/\text{L}$, $\mu\text{g}/\text{m}^3$, ppm_v , and ppb_v . Unlike concentration units for groundwater, these units are not directly interchangeable. The molecular weight (MW) of the compound in question is a factor in the conversion from units of parts per billion (ppb_v) to mass per unit volume ($\mu\text{g}/\text{m}^3$) as follows (API 2005) assuming temperature at 273 K and pressure at 1 atm.:

$$\text{concentration}(\mu\text{g} / \text{m}^3) = \text{concentration}(\text{ppb}_v) \times 0.04 \times \text{MW}$$

USEPA website also provides a useful conversion spreadsheet at:

http://www.epa.gov/athens/learn2model/part-two/onsite/ia_unit_conversion.html

Data are usually reported in table format, which is adequate for understanding and interpreting soil vapor concentrations over time and space. However, depth profiles for multi-level soil vapor sampling probes can be used in order to visualize changes in VOC concentrations and respiration/fixated gases over a given depth interval (as in Figure 12 particularly for assessing biodegradation of petroleum hydrocarbon vapors). Figure 12 shows the vertical soil vapor profiles for benzene vapors sourced from the smear zone or dissolved groundwater plume and oxygen suggesting that downward diffusion of oxygen from surface may have contributed to the significant attenuation of benzene over a 10-ft depth interval due to the aerobic biodegradation of benzene diffusing upward. On the other hand, if higher soil vapor concentrations are detected in the shallower probes than in the deeper probes, it is usually an indication of soil vapors sourced from hydrocarbon



impacted soil in the vadose zone. Plotting data in visual formats often enhances the message that the text is providing.

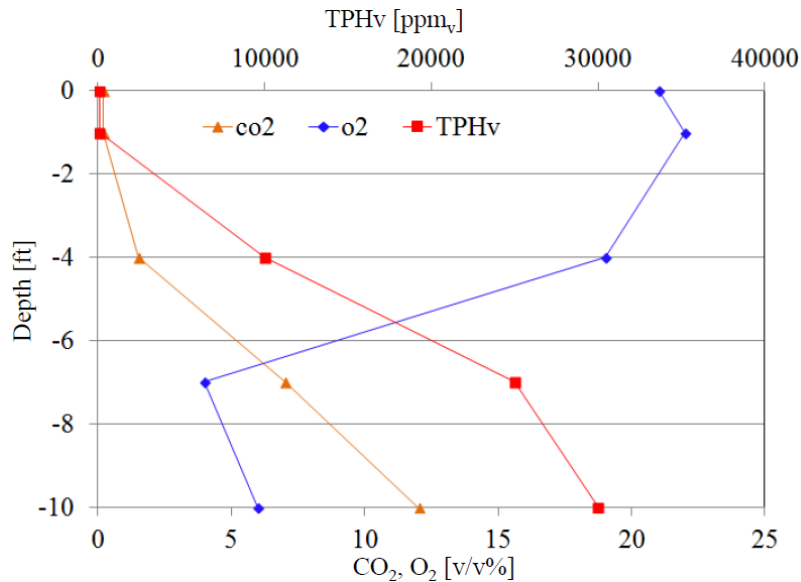

Figure 12. Vertical profile of TPHv, O₂, and CO₂.

7 REFERENCES

Air Toxics Ltd. Evaluating Leaks in a Soil Gas Sample Train
<http://www.airtoxics.com/literature/AirToxicsLeakCheckStudy.pdf>

Air Toxics Ltd. Guide to Air Sampling and Analysis, Canisters and Tedlar Bags
<http://www.airtoxics.com/literature/AirToxicsLtdSamplingGuide.pdf>

Air Toxics Ltd. Impact of Sampling Media on Soil Gas Measurements
<http://www.airtoxics.com/literature/AirToxicsAWMA2006.pdf>

American Petroleum Institute, 2005. Collecting and Interpreting Soil Gas Samples from the Vadose Zone: A Practical Strategy for Assessing the Subsurface-Vapor-to-Indoor-Air Mitigation Pathway at Petroleum Hydrocarbon Sites, Publication #4741.
<http://www.api.org/ehs/groundwater/lnapl/soilgas.cfm>

ASTM, D 5314-92, 2001. Standard Guide for Soil Gas Monitoring in the Vadose Zone.

California EPA, 2003. Advisory – Active Soil Gas Investigation. Jointly issued by the Regional Water Quality Control Board, Los Angeles Region and the Department of Toxic Substances Control.
http://www.dtsc.ca.gov/lawsregspolicies/policies/SiteCleanup/upload/SMBR_ADV_activ_esoilgasinvst.pdf

California EPA, 2012. Advisory Soil Gas Investigations. Jointly issued by Department of Toxic Substances Control Los Angeles Regional Water Quality Control Board



San Francisco Regional Water Quality Control Board

http://www.dtsc.ca.gov/SiteCleanup/upload/VI_ActiveSoilGasAdvisory_FINAL_043012.pdf

California EPA 2011. Final Guidance for the Evaluation and Mitigation of Subsurface Vapor Intrusion to Indoor Air, Department of Toxic Substances Control.
http://www.dtsc.ca.gov/AssessingRisk/upload/Final_VIG_Oct_2011.pdf

CSDDEH (County of San Diego Dept. of Environmental Health), 2002. Site Assessment and Mitigation Manual (SAM Manual).

Dawson, H. & McAlary, T., 2009. A Compilation of Statistics for VOCs from Post -1990 Indoor Air Concentration Studies in North American Residences Unaffected by Subsurface Vapor Intrusion, Ground Water Monitoring & Remediation, 29(1), 60-69.

DiGiulio, D. et al. 2006a Assessment of Vapor Intrusion in Homes Near the Raymark Superfund Site Using Basement and Sub-Slab Air
<http://www.epa.gov/ada/download/reports/600R05147/600R05147.pdf>

DiGiulio, D., Paul C., Scroggins, B., Cody, R., Willey, R., Clifford, S., Mosley, R., Lee, A., Christensen, K., Costa, R., 2006b. EPA/600/R-06/111, Comparison of Geoprobe® PRT and AMS GVP Soil-Gas Sampling Systems with Dedicated Vapor Probes in Sandy Soils at the Raymark Superfund Site,
<http://www.epa.gov/nrmrl/pubs/600R06111/600R06111.pdf>

EPRI 2005. Reference Handbook for Site-Specific Assessment of Subsurface Vapor Intrusion to Indoor Air <http://mydocs.epri.com/docs/public/000000000001008492.pdf>

Hartman, B., 2004. LUSTLine Bulletin no. 48, How to Collect Reliable Soil-Gas Data for Risk-Based Applications-Specifically Vapor Intrusion. Part 3-Answers to Frequently Asked Questions. http://www.neiwpec.org/lustline/lustline_pdf/lustline_48.pdf

Hartman, B., 2006. LUSTLine Bulletin no. 53, How to Collect Reliable Soil-Gas Data for Risk-Based Applications-Specifically Vapor Intrusion. Part 4- Updates on Soil-Gas Collection and Analytical Procedures.
<http://www.handpmg.com/documents/LL53.Blayne.pdf>

Hartman, B., 2008. Results from EPA Research Programs on Sample Flow Rate, Purge Volume, Tubing Type, Tedlar Bags, and Temporal Variations On Soil Gas Concentrations, Presentation given to CA-EPA/DTSC, Los Angeles, CA.

Hayes, H., Benton, D., Grewal, S., Khan, N., 2005, "A Comparison between EPA Compendium Method TO-15 and EPA Method 8260 for VOC Determination in Soil Gas.



Paper #46., AWMA Symposium, San Francisco, CA.

http://www.airtoxics.com/literature/papers/Final_AWMA_TO15_8260.pdf

Health Canada. Soil Vapor Intrusion Guidance for Health Canada Screening Level Risk Assessment (For Vapor Intrusion Applications).

Interstate Technology and Regulatory Council (ITRC), 2007. "Vapor Intrusion Pathway: A Practical Guideline" (<http://www.itcreweb.org/Documents/VI-1.pdf>)

MA DEP 2002. Indoor Air Sampling and Evaluation Guide. Massachusetts Department of Environmental Protection, Boston, MA. April 2002.

<http://www.mass.gov/dep/cleanup/laws/02-430.pdf>

McAlary, T., and T. N. Creamer, 2006. The effects of Purge Rate and Volume on Sub-Slab Soil Gas Samples. Battelle. Remediation of Chlorinated and Recalcitrant Compounds. Monterey, CA. May 2006

Ouellette, G., 2004. Soil Vapor Sampling and Analysis-Lessons Learned Presentation, Inland Empire Analytical, PERF VI Forum, Brea.

State of New Jersey DEP, 2012. Vapor Intrusion Technical Guidance.

http://www.nj.gov/dep/srp/guidance/vaporintrusion/vig_main.pdf

State of New York DOH, 2005. Indoor Air Sampling And Analysis Guidance.

<http://www.health.ny.gov/environmental/indoors/air/docs/guidance.pdf>

State of New York DOH, 2006. Guidance for Evaluating Soil Vapor Intrusion in the State of New York

http://www.health.state.ny.us/environmental/investigations/soil_gas/svi_guidance/docs/svi_main.pdf

US EPA, 1999. Method TO-15. <http://www.epa.gov/ttnamti1/airtox.html>

US EPA, 2002. Draft Guidance for Evaluating the Vapor Intrusion to Indoor Air Pathway from Groundwater and Soils (Subsurface Vapor Intrusion Guidance).

<http://www.epa.gov/osw/hazard/correctiveaction/eis/vapor/complete.pdf>

US EPA, 2006 SF₆ Emission Reduction Partnership for Electric Power Systems.

Additional Resources

<http://www.epa.gov/oust/cat/pvi/index.htm>

This website includes general information on vapor intrusion, along with information on VI guidance documents from different states, and documents on different aspects of VI.

**Soil-Gas Sampling and
Analysis Using USEPA Method
TO-17 and TO-15**

SOP #112409

Rev. #: 2

Rev Date: August 11, 2014

Approval Signatures

Prepared by:  Date: 8/11/2014
Mitch Wacksman, Eric Eple and Andrew Gutherz

Approved by:  Date: 8/11/2014
Nadine Weinberg

I. Scope and Application

This document describes the procedures to collect subsurface soil-gas samples from sub-slab sampling ports and soil vapor monitoring points for the analysis of volatile organic compounds (VOCs) including volatile polyaromatic hydrocarbons (PAHs) by United States Environmental Protection Agency (USEPA) Method TO-17 (TO-17) and USEPA Method TO-15.

The TO-17 method uses a glass or stainless steel tube packed with a sorbent material. Sorbents of increasing strength and composition are packed within the tube. The specific sorbent material packed within each tube is selected based on the target compounds and desired reporting limits. A measured volume of soil-gas is passed through the tube during sample collection.

The TO-15 method uses 1-liter 3-liter or 6-liter SUMMA® passivated stainless steel canister. An evacuated SUMMA canister (less than 28 inches of mercury [Hg]) will provide a recoverable whole-gas sample of approximately 5 liters when allowed to fill to a vacuum of approximately 6 inches of Hg. The whole-air sample is then analyzed for VOCs using a quadrupole or ion-trap gas chromatograph/mass spectrometer (GS/MS) system to provide compound detection limits of 0.5 parts per billion volume (ppbv). Optionally the canister sample can also be analyzed for fixed gasses such as Helium, Carbon dioxide and oxygen.

Following sample collection the TO-17 tube and TO-15 canister is sent to the laboratory where the sampling media is analyzed for the target compounds.

The following sections list the necessary equipment and provide detailed instructions for the collection of soil-gas samples for analysis using TO-17 and TO-15.

Soil vapor samples can be collected from sub-slab sample probes or soil-vapor ports. Refer to the appropriate standard operating procedure (SOP) from the ARCADIS SOP library for a description of construction methods.

II. Personnel Qualifications

ARCADIS field sampling personnel will have current health and safety training, including 40-hour HAZWOPER training, site supervisor training, site-specific training, first-aid, and cardiopulmonary resuscitation (CPR), as needed. ARCADIS field sampling personnel will be well versed in the relevant standard operating procedures (SOPs) and possess the required skills and experience necessary to successfully complete the desired field work. ARCADIS personnel responsible for leading soil-gas sample collection activities must have previous soil-gas sampling experience.

III. Health and Safety Considerations

All sampling personnel should review the appropriate health and safety plan (HASP) and job loss analysis (JLA) prior to beginning work to be aware of all potential hazards associated with the job site and the specific task. Field sampling equipment must be carefully handled to minimize the potential for injury and the spread of hazardous substances. For sub-slab vapor probe installation, drilling with an electric concrete impact drill should be done only by personnel with prior experience using such a piece of equipment and with the appropriate health and safety measures in place as presented in the JLA

IV Equipment List

The equipment required for collect soil-gas samples for analysis using method TO-15 and TO-17 is presented below:

- Appropriate personal protective equipment (PPE; as presented in the site specific HASP and the JLA)
- TO-17 tubes pre-packed by the laboratory with the desired sorbent. Specific sorbents will be recommended by the laboratory considering the target compound list and the necessary reporting limits;
- TO-17 sample flow rate calibration tubes (provided by the laboratory);
- Stainless steel SUMMA[®] canisters (1-liter, 3-liter, or 6-liter; order at least 5% extra, if feasible) (batch certified canisters or individual certified canisters as required by the project)
- Flow controllers with in-line particulate filters and vacuum gauges; flow controllers are pre-calibrated to specified sample duration (e.g., 30 minutes, 8 hours, 24 hours) or flow rate (e.g., 200 milliliters per minute [mL/min]); confirm with the laboratory that the flow controller comes with an in-line particulate filter and pressure gauge (order at least 5% extra, if feasible). Flow rate should be selected based on expected soil type (see below).
- Two decontaminated Swagelok or stainless-steel or comparable two-way ball or needle valve (sized to match sample tubing).
- 1/4-inch outer diameter (OD) tubing (Teflon[®] or Teflon-lined polyethylene);
- Stainless steel or comparable Swagelok[®] or equivalent compression fittings for 1/4-inch OD tubing;

- Stainless steel “T” fitting (if sample train will be assembled with an inline vacuum gauge a four-way fitting will be needed);
- Three Stainless steel duplicate “T” fittings ;
- 2 Portable vacuum pumps capable of producing very low flow rates (e.g., 10 to 200 mL/min) with vacuum gauge;
- Vacuum gauge if monitoring vacuum reading during sample collection is necessary and portable vacuum pump is not equipped with a vacuum gauge;
- Rotameter or an electric flow sensor if vacuum pump does not have a flow gauge (Bios DryCal or equivalent);
- Tracer gas testing supplies (refer to Administering Tracer Gas SOP #41699);
- Photoionization Detector (PID) (with a lamp of 11.7 eV);
- Appropriate-sized open-end wrench (typically 9/16-inch, 1/2-inch , and 3/4-inch);
- 2 Tedlar bags;
- Portable weather meter, if appropriate;
- Chain-of-custody (COC) form;
- Sample collection log;
- Gel ice; and
- Field notebook.

V. Cautions

The following cautions and field tips should be reviewed and considered prior to collecting soil-gas samples.

- Sampling personnel should not handle hazardous substances (such as gasoline), permanent marking pens (sharpies), wear/apply fragrances, or smoke cigarettes/cigars before and/or during the sampling event.
- Care should be taken to ensure that the appropriate sorbent is used in the TO-17 tube preparation. Sorbent should be selected in consultation with the analytical laboratory and in consideration of the target compound list, the necessary reporting limits and the expected range of concentrations in field samples. The expected range of concentrations in field samples may be estimated from previous site data, release history and professional judgment informed by the conceptual site model.
- Flow rates for sample collection with TO-17 sorbent tubes should be determined well in advance of field work in consultation with the laboratory.
- Flow direction on the TO-17 sorbent tubes must be considered. Sorbent tubes are specifically designed to absorb lighter end compound at the influent side of the tube and heavier compounds toward the effluent side of the sorbent tube. Confirm flow direction with analytical laboratory or supplier. The picture below shows a ring indicator on a sorbent tube; this indicates the influent end of the sorbent tube. This ring may also hold labeling clips used to identify the sample. If removed during sample collection or to identify flow direction, remember to replace upon completion. An arrow indicating flow direction may also be printed on the sorbent tube.

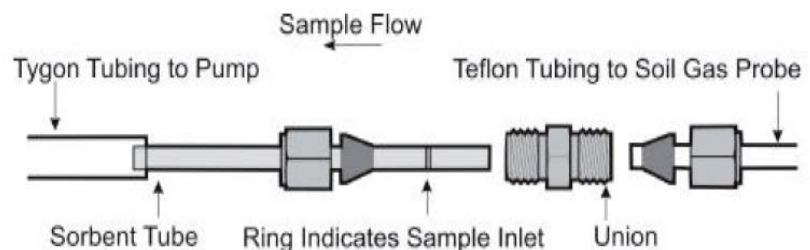

- TO-17 sorbent tubes must be oriented vertically during sampling to ensure equal distribution of compounds along the sorbent media.
- A Shipping Determination must be performed, by DOT-trained personnel, for all environmental samples that are to be shipped, as well as some types of environmental equipment/supplies that are to be shipped.
- At the sampling location, keep the tubes in their storage and transportation container to equilibrate with ambient temperature prior to attaching to the sample train.

- Always use clean gloves when handling sampling tubes.
- Seal clean, blank sorbent tubes and sampled tubes using inert, Swagelok®-type fittings and PTFE ferrules. Wrap capped tubes individually in uncoated aluminum foil. Use clean, sealable glass jars or metal cans containing a small packet of activated charcoal or activated charcoal/silica gel for storage and transportation of multiple tubes. This activated charcoal is not analyzed, but serves as a protection for the analytical sorbent tube. Store the multi-tube storage container in a clean environment at 4°C.
- Keep the sample tubes inside the storage container during transportation and only remove them at the monitoring location after the tubes have reached ambient temperature. Store sampled tubes in a refrigerator at 4°C inside the multi-tube container until ready for analysis.
- The purge flow rate of 100 ml/min should be suitable for a variety of silt and sand conditions but will not be achievable in some clays without excessive vacuum. A low vacuum (<10" of mercury) should be maintained. Record the measured flow rate and vacuum pressure during sample collection.

The cutoff value for vacuum differs in the literature from 10" of water column (ITRC 2007) to 136" of water column or 10" of mercury (http://www.dtsc.ca.gov/lawsregspolicies/policies/SiteCleanup/upload/SMBR_ADV_activesoilgasinvst.pdf). A detailed discussion of the achievable flow rates in various permeability materials can be found in Nicholson 2007. Related issues of contaminant partitioning are summarized in ASTM D5314-92. Passive sampling approaches can be considered as an alternative for clay soils. However most passive sampling approaches are not currently capable of quantitative estimation of soil gas concentration.

- It is important to record the canister pressure, start and stop times and ID on a proper field sampling form. You should observe and record the time/pressure at a mid-point in the sample duration. It is a good practice to lightly tap the pressure gauge with your finger before reading it to make sure it isn't stuck.
- Ensure that there is still measureable vacuum in the SUMMA® after sampling. Sometimes the gauges sent from labs have offset errors, or they stick.
- When sampling carefully consider elevation. If your site is over 2,000' above sea level or the difference in elevation between your site and your lab is more than 2,000' then pressure effects will be significant. If you take your samples at a high elevation they will contain less air for a given ending pressure reading. High elevation samples analyzed at low elevation will result in more dilution at the lab, which could affect reporting limits. Conversely low elevation

samples when received at high elevation may appear to not have much vacuum left in them. http://www.uigi.com/Atmos_pressure.html.

- If possible, have equipment shipped a two or three days before the sampling date so that all materials can be checked. Order replacements if needed.
- Requesting extra canisters and extra sorbent tubes from the laboratory should also be considered to ensure that you have enough equipment on site in case of an equipment failure.
- Shallow exterior soil-gas sampling should not proceed within 5 days following a significant rain event (1/2-inch of rainfall or more).

VI. Procedure

Soil-Gas Sample Preparation

Selection of Sorbent and Sampling Volume (to be completed prior to sampling event)

1. Identify the necessary final reporting limit for the target compound(s) in accordance with the project quality assurance plan and/or in consultation with the data end user.
2. Identify the necessary method reporting limit(s). The laboratory will be helpful in providing this information as it is typically specific to the sensitivity of the instrumentation.
3. The minimum sampling volume is the volume of soil-gas sample that must be drawn through the sorbent in order to achieve the desired final reporting limit. Calculate the minimum sampling volume using the following equation:

$$\text{Minimum Sampling Volume (L)} = \frac{\text{Final Reporting Limit } (\mu\text{g})}{\text{Action Level } (\mu\text{g}/\text{m}^3)} \times \frac{1,000 \text{ L}}{\text{m}^3}$$

Where:

L = liters

μg = microgram

m = meter

4. If a timed sample duration is specified in the work plan, calculate the minimum flow rate. The minimum flow rate is the flow rate necessary to achieve the minimum sampling volume using the following formula:

$$\text{Minimum Flow Rate (L/min)} = \frac{\text{Minimum Sampling Volume (L)}}{\text{Sample Duration (min)}}$$

Where:

min = minutes

Then compare the minimum flow rate calculated to the requirements for maximum soil gas sampling without excessive danger of short circuiting, normally stated as 0.2 liters/minute, although it can be lower in tight soils. Soil vapor sampling flow rates should not exceed 200 ml/min.

5. Compare the minimum sampling volume to the safe sampling volume (SSV) for the sorbents selected. SSV for specific sorbents can be provided by the manufacturer or the laboratory, being used (Table 1 and Appendix 1 in Method TO-17). Ensure that the compound will not breakthrough when sampling the volume calculated above.

Soil-Gas Sample Collection

Calibration of the sample pump prior to assembly of sampling train

1. Attach the sample flow rate calibration tube provided by the laboratory to the inlet of the sample pump using a section of tubing. Attach the flow calibrator to the inlet of the sample flow rate calibration tube. The sample flow rate calibration tube should be clearly marked by the laboratory with an arrow indicating flow direction (or as otherwise specified by the laboratory).
2. Turn on the sample pump and adjust the flow rate on the sample pump to achieve the desired minimum flow rate (calculated above) as measured by the flow calibrator.
3. Repeat until each sampling pump has been properly calibrated to its appropriate flow rate.

Assembly of combined TO-17 and TO-15 sampling train

1. Record the following information in the field notebook, if appropriate (contact the local airport or other suitable information source [e.g., site-specific measurements, weatherunderground.com] to obtain the information):
 - a. wind speed and direction;
 - b. ambient temperature;
 - c. barometric pressure; and
 - d. relative humidity.
2. If samples are being collected from temporary or permanent soil vapor points simply remove the cap or plug and proceed to step 3. When collecting samples from a sub-slab port remove the cap or plug from the sampling port. Connect a short piece of Teflon or Teflon-lined tubing to the sampling port using a Swagelok or equivalent stainless-steel or comparable compression fitting.
3. Connect the Teflon or Teflon-lined tubing to a stainless steel T fitting using a Swagelok or equivalent stainless-steel or comparable compression fitting.
4. Remove the brass cap from the SUMMA® canister and connect the flow controller with in-line particulate filter and vacuum gauge to the SUMMA® canister. Do not open the valve on the SUMMA® canister. Record in the field notebook and COC form the flow controller number with the appropriate SUMMA® canister number.
5. Connect the flow controller to the stainless steel T fitting using a Swagelok or equivalent stainless-steel or comparable compression fitting. The TO-15 leg of the combined sampling train is now complete.
6. Attach a length of Teflon or Teflon-lined tubing to the free end of the stainless steel T fitting using a Swagelok or equivalent stainless-steel or comparable compression fitting.
7. Connect TO-17 sorbent tubes with vertical orientation and the correct flow direction using compression fittings and appropriate T's.
8. Complete the remainder of the sampling train as depicted in Figure 1.

Purge Sampling Assembly and Sampling Point Prior to Sample Collection.

1. Ensure the two-way valve next to the flow rate calibration tube is open and the two way valve next to the TO-17 sampling tubes is closed. Purge three volumes of air from the vapor probe and sampling line using the portable pump. Measure organic vapor levels with the PID. Lower flow rates may be necessary in silt or clay to avoid excessive vacuum. Vacuum reading greater than 136 inches of water column are clearly excessive. Other available sources cite a cutoff of greater than 10 inches of water column.
2. Check the seal established around the soil vapor probe and the sampling train fittings by using a tracer gas (e.g., helium) or other method established in applicable regulatory guidance documents. [Note: Refer to ARCADIS SOP "Administering Tracer Gas," adapted from NYSDOH 2005, for procedures on tracer gas use.]
3. When three volumes of air have been purged from the vapor probe and sampling line stop the purge pump and close the valve next to the flow rate calibration tube.

TO-15 Sample Collection

1. Open the SUMMA® canister valve to initiate sample collection. Record on the sample log (attached) the time sampling began and the canister pressure.

If the initial vacuum pressure registered is not between -30 and -25 inches of Hg, then the SUMMA® canister is not appropriate for use and another canister should be used.

2. Take a photograph of the SUMMA® canister and surrounding area (unless photography is restricted by the property owner).
3. Check the SUMMA canister approximately half way through the sample duration and note progress on sample logs.

TO-15 Sample Termination

1. Arrive at the SUMMA® canister location at least 10 to 15 minutes prior to the end of the sampling interval.
2. Record the final vacuum pressure. Stop collecting the sample by closing the SUMMA® canister valves. The canister should have a minimum amount of vacuum (approximately 6 inches of Hg or slightly greater).

3. Record the date and time of valve closing in the field notebook, sample collection log, and COC form.

TO-17 Sample Collection

1. Record in the field notebook and COC form the tube number on the TO-17 tube.
2. Open the two-way valve next to the TO-17 tubes
3. Turn on the sample pump to begin sample collection. Use a stopwatch to ensure accuracy in pumping time. Record in the field notebook and the field sample log the time sampling began and the flow rate from each of the sample pumps.

Termination of Sample Collection

1. Stop the sample pumps after the desired volume of soil-gas has passed through the sorbent, and close the two-way valves next to the TO-17 sample tubes.
2. Record the stop time.
3. Detach the Tedlar bag from each sample pump and measure the helium concentration in the soil-gas collected by the Tedlar bag. Record any detections in the field book and sample collection log.
4. Open the two-way valve to permit flow through the flow rate calibration tube. Reconnect each of the sampling pumps and measure the flow rate. Record the post-sampling flow rates in the field log book and the sample collection logs. The post-sampling flow rate should match within 10% of the pre-sample flow rate. Average the pre-sampling and post-sampling flow rate and record in the field log book, and the sample collection log.
5. Calculate the sample volume using the average of the pre-sample and post-sample flow rate. Record the sample volume in the field log book, the sample collection log, and on the COC.
6. Package the tubes according to laboratory protocol on gel ice and ship to the laboratory for analysis.

VII. Waste Management

The waste materials generated during sampling activities should be minimal. PPE, such as gloves and other disposable equipment (i.e., tubing), will be collected by field personnel for proper disposal.

VIII. Data Recording and Management

Measurements will be recorded in the field notebook at the time of measurement with notations of the project name, sample date, sample start and finish time, sample location (e.g., GPS coordinates, distance from permanent structure), tube type and number and sample volume. Field sampling logs and COC records will be transmitted to the Project Manager.

IX. Quality Assurance

Duplicate samples should be collected in the field as a quality assurance step. Generally, duplicates are taken of 10% of samples, but project specific requirements should take precedence. Duplicate soil gas samples should be collected via a split sample train, allowing the primary and duplicate sample to be collected from the soil-gas probe simultaneously.

Quality assurance planning for method TO-17 should take careful note of the method requirement for distributed volume pairs. Although in some circumstances this requirement may be waived, this does constitute a deviation from the method as written. It is wise to discuss this decision with clients and/or regulators before sampling.

Soil-gas sample analysis will be performed using USEPA TO-17 methodology for a site specific constituent list defined in the work plan. Constituent lists and reporting limits must be discussed with the laboratory prior to mobilizing for sampling. Quality assurance parameters should be confirmed with the laboratory prior to sampling. Field quality assurance parameters should be defined in the site-specific work plan. A trip blank sample should accompany each shipment of soil-gas samples to the laboratory for analysis. Trip blanks assess potential sample contamination resulting from the transportation and storing of samples. Soil-gas sample analysis will generally be performed using USEPA TO-15 methodology or a project specific constituent list. Method TO-15 uses a quadrupole or ion-trap GC/MS with a capillary column to provide optimum detection limits (typically 0.5-ppbv for most VOCs).

X. References

New York State Department of Health (NYSDOH). 2005. DRAFT "Guidance for Evaluating Soil Vapor Intrusion in the State of New York" February 23, 2005.

AirToxics Ltd. "Sorbent & Solution Sampling Guide."



Appendix C

Chemical Analytical Data for 2013
Soil Vapor Sampling

11/26/2013
Mr. Eric Epple
Arcadis U.S., Inc.
1100 Olive Way
Ste 800
Seattle WA 98101

Project Name: Edmonds Terminal
Project #: B0045362.0004
Workorder #: 1311468A

Dear Mr. Eric Epple

The following report includes the data for the above referenced project for sample(s) received on 11/25/2013 at Air Toxics Ltd.

The data and associated QC analyzed by Modified TO-15 are compliant with the project requirements or laboratory criteria with the exception of the deviations noted in the attached case narrative.

Thank you for choosing Air Toxics Ltd. for your air analysis needs. Air Toxics Ltd. is committed to providing accurate data of the highest quality. Please feel free to contact the Project Manager: Kelly Buettner at 916-985-1000 if you have any questions regarding the data in this report.

Regards,



Kelly Buettner
Project Manager

WORK ORDER #: 1311468A

Work Order Summary

CLIENT:	Mr. Eric Epple Arcadis U.S., Inc. 1100 Olive Way Ste 800 Seattle, WA 98101	BILL TO:	Accounts Payable Arcadis U.S., Inc. 630 Plaza Drive Suite 600 Highlands Ranch, CO 80129
PHONE:	206-726-4728	P.O. #	B0045362.0004
FAX:	206-325-8218	PROJECT #	B0045362.0004 Edmonds Terminal
DATE RECEIVED:	11/25/2013	CONTACT:	Kelly Buettner
DATE COMPLETED:	11/26/2013		

<u>FRACTION #</u>	<u>NAME</u>	<u>TEST</u>	<u>RECEIPT VAC./PRES.</u>	<u>FINAL PRESSURE</u>
01A	VP-1	Modified TO-15	1.8 "Hg	15 psi
02A	VP-2	Modified TO-15	3.1 "Hg	15.1 psi
03A	VP-3	Modified TO-15	1.2 "Hg	14.9 psi
04A	BD-1	Modified TO-15	1.4 "Hg	15 psi
05A	Equipment Blank	Modified TO-15	1 "Hg	15.1 psi
06A	Lab Blank	Modified TO-15	NA	NA
06B	Lab Blank	Modified TO-15	NA	NA
06C	Lab Blank	Modified TO-15	NA	NA
07A	CCV	Modified TO-15	NA	NA
07B	CCV	Modified TO-15	NA	NA
07C	CCV	Modified TO-15	NA	NA
08A	LCS	Modified TO-15	NA	NA
08AA	LCSD	Modified TO-15	NA	NA
08B	LCS	Modified TO-15	NA	NA
08BB	LCSD	Modified TO-15	NA	NA
08C	LCS	Modified TO-15	NA	NA
08CC	LCSD	Modified TO-15	NA	NA

CERTIFIED BY: 
 Technical Director

DATE: 11/26/13

Certification numbers: AZ Licensure AZ0775, CA NELAP - 12282CA, NJ NELAP - CA016, NY NELAP - 11291, TX NELAP - T104704434-13-6, UT NELAP CA009332013-4, VA NELAP - 460197, WA NELAP - C935
 Name of Accrediting Agency: NELAP/ORELAP (Oregon Environmental Laboratory Accreditation Program)
 Accreditation number: CA300005, Effective date: 10/18/2013, Expiration date: 10/17/2014.

Eurofins Air Toxics Inc. certifies that the test results contained in this report meet all requirements of the NELAC standards

This report shall not be reproduced, except in full, without the written approval of Eurofins Air Toxics, Inc.

180 BLUE RAVINE ROAD, SUITE B FOLSOM, CA - 9563
 (916) 985-1000 . (800) 985-5955 . FAX (916) 985-1020



LABORATORY NARRATIVE
Modified TO-15
Arcadis U.S., Inc.
Workorder# 1311468A

Five 1 Liter Summa Canister samples were received on November 25, 2013. The laboratory performed analysis via modified EPA Method TO-15 using GC/MS in the full scan mode.

This workorder was independently validated prior to submittal using 'USEPA National Functional Guidelines' as generally applied to the analysis of volatile organic compounds in air. A rules-based, logic driven, independent validation engine was employed to assess completeness, evaluate pass/fail of relevant project quality control requirements and verification of all quantified amounts.

Method modifications taken to run these samples are summarized in the table below. Specific project requirements may over-ride the ATL modifications.

<i>Requirement</i>	<i>TO-15</i>	<i>ATL Modifications</i>
Initial Calibration	$\leq 30\%$ RSD with 2 compounds allowed out to $< 40\%$ RSD	$\leq 30\%$ RSD with 4 compounds allowed out to $< 40\%$ RSD
Blank and standards	Zero Air	UHP Nitrogen provides a higher purity gas matrix than zero air

Receiving Notes

There were no receiving discrepancies.

Analytical Notes

Samples VP-1, VP-2, VP-3 and BD-1 were transferred from Low Level analysis to full scan TO-15 due to high levels of target/non-target compounds.

Dilution was performed on sample VP-1 due to the presence of high level target species.

Dilution was performed on samples VP-2, VP-3 and BD-1 due to the presence of high level non-target species.

The recovery of surrogate 1,2-Dichloroethane-d4 in sample VP-1 was outside laboratory control limits due to high level hydrocarbon matrix interference. The surrogate recovery is flagged.

Definition of Data Qualifying Flags

Eight qualifiers may have been used on the data analysis sheets and indicates as follows:

B - Compound present in laboratory blank greater than reporting limit (background subtraction not performed).

J - Estimated value.

E - Exceeds instrument calibration range.

S - Saturated peak.

Q - Exceeds quality control limits.

U - Compound analyzed for but not detected above the reporting limit, LOD, or MDL value. See

data page for project specific U-flag definition.

UJ- Non-detected compound associated with low bias in the CCV

N - The identification is based on presumptive evidence.

File extensions may have been used on the data analysis sheets and indicates as follows:

a-File was requantified

b-File was quantified by a second column and detector

r1-File was requantified for the purpose of reissue

**Summary of Detected Compounds
EPA METHOD TO-15 GC/MS**

Client Sample ID: VP-1

Lab ID#: 1311468A-01A

Compound	Rpt. Limit (ppbv)	Amount (ppbv)	Rpt. Limit (ug/m3)	Amount (ug/m3)
Benzene	540	220000	1700	710000

Client Sample ID: VP-2

Lab ID#: 1311468A-02A

Compound	Rpt. Limit (ppbv)	Amount (ppbv)	Rpt. Limit (ug/m3)	Amount (ug/m3)
Benzene	4.5	100	14	340

Client Sample ID: VP-3

Lab ID#: 1311468A-03A

Compound	Rpt. Limit (ppbv)	Amount (ppbv)	Rpt. Limit (ug/m3)	Amount (ug/m3)
Benzene	10	14	34	46

Client Sample ID: BD-1

Lab ID#: 1311468A-04A

Compound	Rpt. Limit (ppbv)	Amount (ppbv)	Rpt. Limit (ug/m3)	Amount (ug/m3)
Benzene	4.2	94	14	300

Client Sample ID: Equipment Blank

Lab ID#: 1311468A-05A

No Detections Were Found.

Client Sample ID: VP-1

Lab ID#: 1311468A-01A

EPA METHOD TO-15 GC/MS

File Name:	14112524	Date of Collection:	11/21/13 12:44:00 P
Dil. Factor:	108	Date of Analysis:	11/26/13 08:44 AM

Compound	Rpt. Limit (ppbv)	Amount (ppbv)	Rpt. Limit (ug/m3)	Amount (ug/m3)
Benzene	540	220000	1700	710000
Naphthalene	2200	Not Detected	11000	Not Detected

Q = Exceeds Quality Control limits of 70% to 130%, due to matrix effects.

Container Type: 1 Liter Summa Canister

Surrogates	%Recovery	Method Limits
1,2-Dichloroethane-d4	157 Q	70-130
Toluene-d8	90	70-130
4-Bromofluorobenzene	94	70-130

Client Sample ID: VP-2

Lab ID#: 1311468A-02A

EPA METHOD TO-15 GC/MS FULL SCAN

File Name:	3112513	Date of Collection:	11/21/13 11:30:00 A
Dil. Factor:	9.04	Date of Analysis:	11/26/13 11:40 AM

Compound	Rpt. Limit (ppbv)	Amount (ppbv)	Rpt. Limit (ug/m3)	Amount (ug/m3)
Benzene	4.5	100	14	340
Naphthalene	18	Not Detected	95	Not Detected

Container Type: 1 Liter Summa Canister

Surrogates	%Recovery	Method Limits
Toluene-d8	102	70-130
1,2-Dichloroethane-d4	81	70-130
4-Bromofluorobenzene	104	70-130



Air Toxics

Client Sample ID: VP-3

Lab ID#: 1311468A-03A

EPA METHOD TO-15 GC/MS FULL SCAN

File Name:	3112514	Date of Collection:	11/21/13 10:10:00 A
Dil. Factor:	21.0	Date of Analysis:	11/26/13 12:22 PM

Compound	Rpt. Limit (ppbv)	Amount (ppbv)	Rpt. Limit (ug/m3)	Amount (ug/m3)
Benzene	10	14	34	46
Naphthalene	42	Not Detected	220	Not Detected

Container Type: 1 Liter Summa Canister

Surrogates	%Recovery	Method Limits
Toluene-d8	102	70-130
1,2-Dichloroethane-d4	107	70-130
4-Bromofluorobenzene	106	70-130



Air Toxics

Client Sample ID: BD-1

Lab ID#: 1311468A-04A

EPA METHOD TO-15 GC/MS FULL SCAN

File Name:	3112511	Date of Collection:	11/21/13
Dil. Factor:	8.48	Date of Analysis:	11/26/13 10:37 AM

Compound	Rpt. Limit (ppbv)	Amount (ppbv)	Rpt. Limit (ug/m3)	Amount (ug/m3)
Benzene	4.2	94	14	300
Naphthalene	17	Not Detected	89	Not Detected

Container Type: 1 Liter Summa Canister

Surrogates	%Recovery	Method Limits
Toluene-d8	103	70-130
1,2-Dichloroethane-d4	90	70-130
4-Bromofluorobenzene	106	70-130



Air Toxics

Client Sample ID: Equipment Blank

Lab ID#: 1311468A-05A

MODIFIED EPA METHOD TO-15 GC/MS FULL SCAN

File Name:	e112516	Date of Collection:	11/21/13 1:08:00 PM
Dil. Factor:	2.10	Date of Analysis:	11/26/13 09:12 AM

Compound	Rpt. Limit (ppbv)	Amount (ppbv)	Rpt. Limit (ug/m3)	Amount (ug/m3)
Benzene	0.21	Not Detected	0.67	Not Detected
Naphthalene	1.0	Not Detected	5.5	Not Detected

Container Type: 1 Liter Summa Canister

Surrogates	%Recovery	Method Limits
1,2-Dichloroethane-d4	98	70-130
Toluene-d8	98	70-130
4-Bromofluorobenzene	100	70-130



Air Toxics

Client Sample ID: Lab Blank

Lab ID#: 1311468A-06A

EPA METHOD TO-15 GC/MS

File Name:	14112506	Date of Collection:	NA
Dil. Factor:	1.00	Date of Analysis:	11/25/13 04:09 PM

Compound	Rpt. Limit (ppbv)	Amount (ppbv)	Rpt. Limit (ug/m3)	Amount (ug/m3)
Benzene	5.0	Not Detected	16	Not Detected
Naphthalene	20	Not Detected	100	Not Detected

Container Type: NA - Not Applicable

Surrogates	%Recovery	Method Limits
1,2-Dichloroethane-d4	101	70-130
Toluene-d8	95	70-130
4-Bromofluorobenzene	93	70-130

Client Sample ID: Lab Blank

Lab ID#: 1311468A-06B

MODIFIED EPA METHOD TO-15 GC/MS FULL SCAN

File Name:	e112514	Date of Collection:	NA
Dil. Factor:	1.00	Date of Analysis:	11/25/13 09:34 PM

Compound	Rpt. Limit (ppbv)	Amount (ppbv)	Rpt. Limit (ug/m3)	Amount (ug/m3)
Benzene	0.10	Not Detected	0.32	Not Detected
Naphthalene	0.50	Not Detected	2.6	Not Detected

Container Type: NA - Not Applicable

Surrogates	%Recovery	Method Limits
1,2-Dichloroethane-d4	99	70-130
Toluene-d8	97	70-130
4-Bromofluorobenzene	99	70-130



Air Toxics

Client Sample ID: Lab Blank

Lab ID#: 1311468A-06C

EPA METHOD TO-15 GC/MS FULL SCAN

File Name:	3112509	Date of Collection:	NA
Dil. Factor:	1.00	Date of Analysis:	11/26/13 09:08 AM

Compound	Rpt. Limit (ppbv)	Amount (ppbv)	Rpt. Limit (ug/m3)	Amount (ug/m3)
Benzene	0.50	Not Detected	1.6	Not Detected
Naphthalene	2.0	Not Detected	10	Not Detected

Container Type: NA - Not Applicable

Surrogates	%Recovery	Method Limits
Toluene-d8	103	70-130
1,2-Dichloroethane-d4	82	70-130
4-Bromofluorobenzene	105	70-130

Client Sample ID: CCV

Lab ID#: 1311468A-07A

EPA METHOD TO-15 GC/MS

File Name:	14112502	Date of Collection: NA
Dil. Factor:	1.00	Date of Analysis: 11/25/13 12:55 PM

Compound	%Recovery
Benzene	105
Naphthalene	103

Container Type: NA - Not Applicable

Surrogates	%Recovery	Method Limits
1,2-Dichloroethane-d4	98	70-130
Toluene-d8	104	70-130
4-Bromofluorobenzene	102	70-130

Client Sample ID: CCV

Lab ID#: 1311468A-07B

MODIFIED EPA METHOD TO-15 GC/MS FULL SCAN

File Name:	e112510	Date of Collection: NA
Dil. Factor:	1.00	Date of Analysis: 11/25/13 06:30 PM

Compound	%Recovery
Benzene	87
Naphthalene	78

Container Type: NA - Not Applicable

Surrogates	%Recovery	Method Limits
1,2-Dichloroethane-d4	100	70-130
Toluene-d8	103	70-130
4-Bromofluorobenzene	104	70-130

Client Sample ID: CCV

Lab ID#: 1311468A-07C

EPA METHOD TO-15 GC/MS FULL SCAN

File Name:	3112502	Date of Collection: NA
Dil. Factor:	1.00	Date of Analysis: 11/25/13 09:24 PM

Compound	%Recovery
Benzene	115
Naphthalene	95

Container Type: NA - Not Applicable

Surrogates	%Recovery	Method Limits
Toluene-d8	108	70-130
1,2-Dichloroethane-d4	82	70-130
4-Bromofluorobenzene	108	70-130



Air Toxics

Client Sample ID: LCS

Lab ID#: 1311468A-08A

EPA METHOD TO-15 GC/MS

File Name:	14112503	Date of Collection: NA
Dil. Factor:	1.00	Date of Analysis: 11/25/13 01:42 PM

Compound	%Recovery	Method Limits
Benzene	94	70-130
Naphthalene	87	60-140

Container Type: NA - Not Applicable

Surrogates	%Recovery	Method Limits
1,2-Dichloroethane-d4	100	70-130
Toluene-d8	101	70-130
4-Bromofluorobenzene	100	70-130

Client Sample ID: LCSD

Lab ID#: 1311468A-08AA

EPA METHOD TO-15 GC/MS

File Name:	14112504	Date of Collection: NA
Dil. Factor:	1.00	Date of Analysis: 11/25/13 03:01 PM

Compound	%Recovery	Method Limits
Benzene	95	70-130
Naphthalene	78	60-140

Container Type: NA - Not Applicable

Surrogates	%Recovery	Method Limits
1,2-Dichloroethane-d4	102	70-130
Toluene-d8	100	70-130
4-Bromofluorobenzene	101	70-130



Air Toxics

Client Sample ID: LCS

Lab ID#: 1311468A-08B

MODIFIED EPA METHOD TO-15 GC/MS FULL SCAN

File Name:	e112511	Date of Collection: NA
Dil. Factor:	1.00	Date of Analysis: 11/25/13 07:15 PM

Compound	%Recovery	Method Limits
Benzene	91	70-130
Naphthalene	100	60-140

Container Type: NA - Not Applicable

Surrogates	%Recovery	Method Limits
1,2-Dichloroethane-d4	98	70-130
Toluene-d8	100	70-130
4-Bromofluorobenzene	103	70-130



Air Toxics

Client Sample ID: LCSD

Lab ID#: 1311468A-08BB

MODIFIED EPA METHOD TO-15 GC/MS FULL SCAN

File Name:	e112512	Date of Collection: NA
Dil. Factor:	1.00	Date of Analysis: 11/25/13 07:55 PM

Compound	%Recovery	Method Limits
Benzene	86	70-130
Naphthalene	94	60-140

Container Type: NA - Not Applicable

Surrogates	%Recovery	Method Limits
1,2-Dichloroethane-d4	102	70-130
Toluene-d8	97	70-130
4-Bromofluorobenzene	105	70-130

Client Sample ID: LCS

Lab ID#: 1311468A-08C

EPA METHOD TO-15 GC/MS FULL SCAN

File Name:	3112505	Date of Collection: NA
Dil. Factor:	1.00	Date of Analysis: 11/25/13 10:56 PM

Compound	%Recovery	Method Limits
Benzene	122	70-130
Naphthalene	58 Q	60-140

Q = Exceeds Quality Control limits.

Container Type: NA - Not Applicable

Surrogates	%Recovery	Method Limits
Toluene-d8	105	70-130
1,2-Dichloroethane-d4	80	70-130
4-Bromofluorobenzene	108	70-130



Air Toxics

Client Sample ID: LCSD

Lab ID#: 1311468A-08CC

EPA METHOD TO-15 GC/MS FULL SCAN

File Name:	3112506	Date of Collection: NA
Dil. Factor:	1.00	Date of Analysis: 11/25/13 11:25 PM

Compound	%Recovery	Method Limits
Benzene	120	70-130
Naphthalene	61	60-140

Container Type: NA - Not Applicable

Surrogates	%Recovery	Method Limits
Toluene-d8	102	70-130
1,2-Dichloroethane-d4	82	70-130
4-Bromofluorobenzene	109	70-130

11/27/2013
Mr. Eric Epple
Arcadis U.S., Inc.
1100 Olive Way
Ste 800
Seattle WA 98101

Project Name: Edmonds Terminal
Project #: B0045362.0004
Workorder #: 1311468B

Dear Mr. Eric Epple

The following report includes the data for the above referenced project for sample(s) received on 11/25/2013 at Air Toxics Ltd.

The data and associated QC analyzed by Modified TO-15 APH are compliant with the project requirements or laboratory criteria with the exception of the deviations noted in the attached case narrative.

Thank you for choosing Air Toxics Ltd. for your air analysis needs. Air Toxics Ltd. is committed to providing accurate data of the highest quality. Please feel free to contact the Project Manager: Kelly Buettner at 916-985-1000 if you have any questions regarding the data in this report.

Regards,



Kelly Buettner
Project Manager

WORK ORDER #: 1311468B

Work Order Summary

CLIENT:	Mr. Eric Epple Arcadis U.S., Inc. 1100 Olive Way Ste 800 Seattle, WA 98101	BILL TO:	Accounts Payable Arcadis U.S., Inc. 630 Plaza Drive Suite 600 Highlands Ranch, CO 80129
PHONE:	206-726-4728	P.O. #	B0045362.0004
FAX:	206-325-8218	PROJECT #	B0045362.0004 Edmonds Terminal
DATE RECEIVED:	11/25/2013	CONTACT:	Kelly Buettner
DATE COMPLETED:	11/27/2013		

<u>FRACTION #</u>	<u>NAME</u>	<u>TEST</u>	<u>RECEIPT VAC./PRES.</u>	<u>FINAL PRESSURE</u>
01A	VP-1	Modified TO-15 APH	1.8 "Hg	15 psi
01B	VP-1	Modified TO-15 APH	1.8 "Hg	15 psi
02A	VP-2	Modified TO-15 APH	3.1 "Hg	15.1 psi
02B	VP-2	Modified TO-15 APH	3.1 "Hg	15.1 psi
03A	VP-3	Modified TO-15 APH	1.2 "Hg	14.9 psi
03B	VP-3	Modified TO-15 APH	1.2 "Hg	14.9 psi
04A	BD-1	Modified TO-15 APH	1.4 "Hg	15 psi
04B	BD-1	Modified TO-15 APH	1.4 "Hg	15 psi
05A	Equipment Blank	Modified TO-15 APH	1 "Hg	15.1 psi
05B	Equipment Blank	Modified TO-15 APH	1 "Hg	15.1 psi
06A	Lab Blank	Modified TO-15 APH	NA	NA
06B	Lab Blank	Modified TO-15 APH	NA	NA
06C	Lab Blank	Modified TO-15 APH	NA	NA
06D	Lab Blank	Modified TO-15 APH	NA	NA
07A	CCV	Modified TO-15 APH	NA	NA
07B	CCV	Modified TO-15 APH	NA	NA
07C	CCV	Modified TO-15 APH	NA	NA
07D	CCV	Modified TO-15 APH	NA	NA

CERTIFIED BY: 
 Technical Director

DATE: 11/27/13

Certification numbers: AZ Licensure AZ0775, CA NELAP - 12282CA, NJ NELAP - CA016, NY NELAP - 11291,
 TX NELAP - T104704434-13-6, UT NELAP CA009332013-4, VA NELAP - 460197, WA NELAP - C935
 Name of Accrediting Agency: NELAP/ORELAP (Oregon Environmental Laboratory Accreditation Program)
 Accreditation number: CA300005, Effective date: 10/18/2013, Expiration date: 10/17/2014.

Eurofins Air Toxics Inc.. certifies that the test results contained in this report meet all requirements of the NELAC standards

This report shall not be reproduced, except in full, without the written approval of Eurofins Air Toxics, Inc.
 180 BLUE RAVINE ROAD, SUITE B FOLSOM, CA - 95602
 (916) 985-1000 . (800) 985-5955 . FAX (916) 985-1020



LABORATORY NARRATIVE
Modified TO-15 & VPH Fractions
Arcadis U.S., Inc.
Workorder# 1311468B

Five 1 Liter Summa Canister samples were received on November 25, 2013. The laboratory performed analysis via EPA Method TO-15 and Air Toxics VPH (Volatile Petroleum Hydrocarbon) methods for the Determination of VPH Fractions using GC/MS in the full scan mode. The method involves concentrating up to 0.5 liters of air. The concentrated aliquot is then flash vaporized and swept through a water management system to remove water vapor. Following dehumidification, the sample passes directly into the GC/MS for analysis. This method is designed to measure gaseous phase aliphatic and aromatic compounds in ambient air and soil gas collected in stainless steel Summa canisters. Air Toxics VPH method is a hybrid of EPA TO-15, MADEP APH and WSDE VPH methods. Chromatographic peaks were identified via mass spectrum as either aliphatic or aromatic petroleum hydrocarbons and included in the appropriate range as defined by the method. The volatile Aliphatic hydrocarbons are collectively quantified within the C5 to C6 range, C6 to C8 range, C8 to C10 range and the C10 to C12 range. Additionally, the volatile Aromatic hydrocarbons are collectively quantified within the C8 to C10 range and the C10 to C12 range. The Aromatic ranges refer to the equivalent carbon (EC) ranges.

Aliphatic data is calculated from the Total Ion chromatogram which has been reprocessed in a duplicate file differentiated from the original by the addition of an alphanumeric extension. The Aromatic calculation also uses the information contained in the associated Extracted Ion file.

Receiving Notes

There were no receiving discrepancies.

Analytical Notes

Dilution was performed on samples VP-1, VP-2, VP-3 and BD-1 due to matrix interference.

Definition of Data Qualifying Flags

Eight qualifiers may have been used on the data analysis sheets and indicates as follows:

B - Compound present in laboratory blank greater than reporting limit (background subtraction not performed).

J - Estimated value.

E - Exceeds instrument calibration range.

S - Saturated peak.

Q - Exceeds quality control limits.

U - Compound analyzed for but not detected above the reporting limit.

UJ- Non-detected compound associated with low bias in the CCV

N - The identification is based on presumptive evidence.

File extensions may have been used on the data analysis sheets and indicates as follows:

a-File was requantified

b-File was quantified by a second column and detector

r1-File was requantified for the purpose of reissue

Summary of Detected Compounds

MODIFIED METHOD TO-15 GC/MS FULL SCAN

Client Sample ID: VP-1

Lab ID#: 1311468B-01A

Compound	Rpt. Limit (ppbv)	Amount (ppbv)	Rpt. Limit (ug/m3)	Amount (ug/m3)
C5-C6 Aliphatic Hydrocarbons (ref. to Pentane + Hexane)	22000	4700000	70000	15000000
>C6-C8 Aliphatic Hydrocarbons (ref. to Heptane)	22000	4900000	88000	20000000
>C8-C10 Aliphatic Hydrocarbons (ref. to Decane)	22000	1100000	120000	6600000

Client Sample ID: VP-1

Lab ID#: 1311468B-01B

Compound	Rpt. Limit (ppbv)	Amount (ppbv)	Rpt. Limit (ug/m3)	Amount (ug/m3)
>C8-C10 Aromatic Hydrocarbons (ref. to 1,2,3-TMB)	22000	7000	100000	34000

Client Sample ID: VP-2

Lab ID#: 1311468B-02A

Compound	Rpt. Limit (ppbv)	Amount (ppbv)	Rpt. Limit (ug/m3)	Amount (ug/m3)
C5-C6 Aliphatic Hydrocarbons (ref. to Pentane + Hexane)	90	1800	290	5700
>C6-C8 Aliphatic Hydrocarbons (ref. to Heptane)	90	6800	370	28000
>C8-C10 Aliphatic Hydrocarbons (ref. to Decane)	90	4300	530	25000
>C10-C12 Aliphatic Hydrocarbons (ref. to Dodecane)	90	1600	630	11000

Client Sample ID: VP-2

Lab ID#: 1311468B-02B

Compound	Rpt. Limit (ppbv)	Amount (ppbv)	Rpt. Limit (ug/m3)	Amount (ug/m3)
>C8-C10 Aromatic Hydrocarbons (ref. to 1,2,3-TMB)	90	240	440	1200

Client Sample ID: VP-3

Lab ID#: 1311468B-03A

Summary of Detected Compounds MODIFIED METHOD TO-15 GC/MS FULL SCAN

Client Sample ID: VP-3

Lab ID#: 1311468B-03A

Compound	Rpt. Limit (ppbv)	Amount (ppbv)	Rpt. Limit (ug/m3)	Amount (ug/m3)
C5-C6 Aliphatic Hydrocarbons (ref. to Pentane + Hexane)	350	15000	1100	49000
>C6-C8 Aliphatic Hydrocarbons (ref. to Heptane)	350	120000	1400	480000
>C8-C10 Aliphatic Hydrocarbons (ref. to Decane)	350	48000	2000	280000
>C10-C12 Aliphatic Hydrocarbons (ref. to Dodecane)	350	3600	2400	25000

Client Sample ID: VP-3

Lab ID#: 1311468B-03B

No Detections Were Found.

Client Sample ID: BD-1

Lab ID#: 1311468B-04A

Compound	Rpt. Limit (ppbv)	Amount (ppbv)	Rpt. Limit (ug/m3)	Amount (ug/m3)
C5-C6 Aliphatic Hydrocarbons (ref. to Pentane + Hexane)	85	1500	270	4800
>C6-C8 Aliphatic Hydrocarbons (ref. to Heptane)	85	5700	350	23000
>C8-C10 Aliphatic Hydrocarbons (ref. to Decane)	85	2600	490	15000
>C10-C12 Aliphatic Hydrocarbons (ref. to Dodecane)	85	1500	590	10000

Client Sample ID: BD-1

Lab ID#: 1311468B-04B

Compound	Rpt. Limit (ppbv)	Amount (ppbv)	Rpt. Limit (ug/m3)	Amount (ug/m3)
>C8-C10 Aromatic Hydrocarbons (ref. to 1,2,3-TMB)	85	210	420	1000

Client Sample ID: Equipment Blank

Lab ID#: 1311468B-05A

No Detections Were Found.

Summary of Detected Compounds
MODIFIED METHOD TO-15 GC/MS FULL SCAN

Client Sample ID: Equipment Blank

Lab ID#: 1311468B-05B

No Detections Were Found.



Air Toxics

Client Sample ID: VP-1

Lab ID#: 1311468B-01A

MODIFIED METHOD TO-15 GC/MS FULL SCAN

File Name:	14112619a	Date of Collection:	11/21/13 12:44:00 PM
Dil. Factor:	430	Date of Analysis:	11/27/13 07:34 AM

Compound	Rpt. Limit (ppbv)	Amount (ppbv)	Rpt. Limit (ug/m3)	Amount (ug/m3)
C5-C6 Aliphatic Hydrocarbons (ref. to Pentane + Hexane)	22000	4700000	70000	15000000
>C6-C8 Aliphatic Hydrocarbons (ref. to Heptane)	22000	4900000	88000	20000000
>C8-C10 Aliphatic Hydrocarbons (ref. to Decane)	22000	1100000	120000	6600000
>C10-C12 Aliphatic Hydrocarbons (ref. to Dodecane)	22000	Not Detected	150000	Not Detected

Container Type: 1 Liter Summa Canister



Air Toxics

Client Sample ID: VP-1

Lab ID#: 1311468B-01B

MODIFIED METHOD TO-15 GC/MS FULL SCAN

File Name:	14112619c	Date of Collection:	11/21/13 12:44:00 PM	
Dil. Factor:	430	Date of Analysis:	11/27/13 07:34 AM	

Compound	Rpt. Limit (ppbv)	Amount (ppbv)	Rpt. Limit (ug/m3)	Amount (ug/m3)
>C8-C10 Aromatic Hydrocarbons (ref. to 1,2,3-TMB)	22000	7000	100000	34000
>C10-C12 Aromatic Hydrocarbons (ref. to 1,2,4,5-TMB)	22000	Not Detected	120000	Not Detected

Container Type: 1 Liter Summa Canister

Client Sample ID: VP-2

Lab ID#: 1311468B-02A

MODIFIED METHOD TO-15 GC/MS FULL SCAN

File Name:	3112513a	Date of Collection: 11/21/13 11:30:00 AM
Dil. Factor:	9.04	Date of Analysis: 11/26/13 11:40 AM

Compound	Rpt. Limit (ppbv)	Amount (ppbv)	Rpt. Limit (ug/m3)	Amount (ug/m3)
C5-C6 Aliphatic Hydrocarbons (ref. to Pentane + Hexane)	90	1800	290	5700
>C6-C8 Aliphatic Hydrocarbons (ref. to Heptane)	90	6800	370	28000
>C8-C10 Aliphatic Hydrocarbons (ref. to Decane)	90	4300	530	25000
>C10-C12 Aliphatic Hydrocarbons (ref. to Dodecane)	90	1600	630	11000

Container Type: 1 Liter Summa Canister



Air Toxics

Client Sample ID: VP-2

Lab ID#: 1311468B-02B

MODIFIED METHOD TO-15 GC/MS FULL SCAN

File Name:	3112513c	Date of Collection:	11/21/13 11:30:00 AM
Dil. Factor:	9.04	Date of Analysis:	11/26/13 11:40 AM

Compound	Rpt. Limit (ppbv)	Amount (ppbv)	Rpt. Limit (ug/m3)	Amount (ug/m3)
>C8-C10 Aromatic Hydrocarbons (ref. to 1,2,3-TMB)	90	240	440	1200
>C10-C12 Aromatic Hydrocarbons (ref. to 1,2,4,5-TMB)	90	Not Detected	500	Not Detected

Container Type: 1 Liter Summa Canister



Air Toxics

Client Sample ID: VP-3

Lab ID#: 1311468B-03A

MODIFIED METHOD TO-15 GC/MS FULL SCAN

File Name:	14112622a	Date of Collection:	11/21/13 10:10:00 AM
Dil. Factor:	7.00	Date of Analysis:	11/27/13 09:14 AM

Compound	Rpt. Limit (ppbv)	Amount (ppbv)	Rpt. Limit (ug/m3)	Amount (ug/m3)
C5-C6 Aliphatic Hydrocarbons (ref. to Pentane + Hexane)	350	15000	1100	49000
>C6-C8 Aliphatic Hydrocarbons (ref. to Heptane)	350	120000	1400	480000
>C8-C10 Aliphatic Hydrocarbons (ref. to Decane)	350	48000	2000	280000
>C10-C12 Aliphatic Hydrocarbons (ref. to Dodecane)	350	3600	2400	25000

Container Type: 1 Liter Summa Canister



Air Toxics

Client Sample ID: VP-3

Lab ID#: 1311468B-03B

MODIFIED METHOD TO-15 GC/MS FULL SCAN

File Name:	14112622c	Date of Collection:	11/21/13 10:10:00 AM	
Dil. Factor:	7.00	Date of Analysis:	11/27/13 09:14 AM	

Compound	Rpt. Limit (ppbv)	Amount (ppbv)	Rpt. Limit (ug/m3)	Amount (ug/m3)
>C8-C10 Aromatic Hydrocarbons (ref. to 1,2,3-TMB)	350	Not Detected	1700	Not Detected
>C10-C12 Aromatic Hydrocarbons (ref. to 1,2,4,5-TMB)	350	Not Detected	1900	Not Detected

Container Type: 1 Liter Summa Canister



Air Toxics

Client Sample ID: BD-1

Lab ID#: 1311468B-04A

MODIFIED METHOD TO-15 GC/MS FULL SCAN

File Name:	3112511a	Date of Collection:	11/21/13
Dil. Factor:	8.48	Date of Analysis:	11/26/13 10:37 AM

Compound	Rpt. Limit (ppbv)	Amount (ppbv)	Rpt. Limit (ug/m3)	Amount (ug/m3)
C5-C6 Aliphatic Hydrocarbons (ref. to Pentane + Hexane)	85	1500	270	4800
>C6-C8 Aliphatic Hydrocarbons (ref. to Heptane)	85	5700	350	23000
>C8-C10 Aliphatic Hydrocarbons (ref. to Decane)	85	2600	490	15000
>C10-C12 Aliphatic Hydrocarbons (ref. to Dodecane)	85	1500	590	10000

Container Type: 1 Liter Summa Canister



Air Toxics

Client Sample ID: BD-1

Lab ID#: 1311468B-04B

MODIFIED METHOD TO-15 GC/MS FULL SCAN

File Name:	3112511c	Date of Collection:	11/21/13	
Dil. Factor:	8.48	Date of Analysis:	11/26/13 10:37 AM	

Compound	Rpt. Limit (ppbv)	Amount (ppbv)	Rpt. Limit (ug/m3)	Amount (ug/m3)
>C8-C10 Aromatic Hydrocarbons (ref. to 1,2,3-TMB)	85	210	420	1000
>C10-C12 Aromatic Hydrocarbons (ref. to 1,2,4,5-TMB)	85	Not Detected	460	Not Detected

Container Type: 1 Liter Summa Canister



Air Toxics

Client Sample ID: Equipment Blank

Lab ID#: 1311468B-05A

MODIFIED METHOD TO-15 GC/MS FULL SCAN

File Name:	3112510a	Date of Collection:	11/21/13 1:08:00 PM
Dil. Factor:	2.10	Date of Analysis:	11/26/13 09:57 AM

Compound	Rpt. Limit (ppbv)	Amount (ppbv)	Rpt. Limit (ug/m3)	Amount (ug/m3)
C5-C6 Aliphatic Hydrocarbons (ref. to Pentane + Hexane)	21	Not Detected	68	Not Detected
>C6-C8 Aliphatic Hydrocarbons (ref. to Heptane)	21	Not Detected	86	Not Detected
>C8-C10 Aliphatic Hydrocarbons (ref. to Decane)	21	Not Detected	120	Not Detected
>C10-C12 Aliphatic Hydrocarbons (ref. to Dodecane)	21	Not Detected	150	Not Detected

Container Type: 1 Liter Summa Canister



Air Toxics

Client Sample ID: Equipment Blank

Lab ID#: 1311468B-05B

MODIFIED METHOD TO-15 GC/MS FULL SCAN

File Name:	3112510c	Date of Collection:	11/21/13 1:08:00 PM
Dil. Factor:	2.10	Date of Analysis:	11/26/13 09:57 AM

Compound	Rpt. Limit (ppbv)	Amount (ppbv)	Rpt. Limit (ug/m3)	Amount (ug/m3)
>C8-C10 Aromatic Hydrocarbons (ref. to 1,2,3-TMB)	21	Not Detected	100	Not Detected
>C10-C12 Aromatic Hydrocarbons (ref. to 1,2,4,5-TMB)	21	Not Detected	120	Not Detected

Container Type: 1 Liter Summa Canister



Air Toxics

Client Sample ID: Lab Blank

Lab ID#: 1311468B-06A

MODIFIED METHOD TO-15 GC/MS FULL SCAN

File Name:	3112509a	Date of Collection:	NA
Dil. Factor:	1.00	Date of Analysis:	11/26/13 09:08 AM

Compound	Rpt. Limit (ppbv)	Amount (ppbv)	Rpt. Limit (ug/m3)	Amount (ug/m3)
C5-C6 Aliphatic Hydrocarbons (ref. to Pentane + Hexane)	10	Not Detected	32	Not Detected
>C6-C8 Aliphatic Hydrocarbons (ref. to Heptane)	10	Not Detected	41	Not Detected
>C8-C10 Aliphatic Hydrocarbons (ref. to Decane)	10	Not Detected	58	Not Detected
>C10-C12 Aliphatic Hydrocarbons (ref. to Dodecane)	10	Not Detected	70	Not Detected

Container Type: NA - Not Applicable



Air Toxics

Client Sample ID: Lab Blank

Lab ID#: 1311468B-06B

MODIFIED METHOD TO-15 GC/MS FULL SCAN

File Name:	3112509c	Date of Collection:	NA
Dil. Factor:	1.00	Date of Analysis:	11/26/13 09:08 AM

Compound	Rpt. Limit (ppbv)	Amount (ppbv)	Rpt. Limit (ug/m3)	Amount (ug/m3)
>C8-C10 Aromatic Hydrocarbons (ref. to 1,2,3-TMB)	10	Not Detected	49	Not Detected
>C10-C12 Aromatic Hydrocarbons (ref. to 1,2,4,5-TMB)	10	Not Detected	55	Not Detected

Container Type: NA - Not Applicable



Air Toxics

Client Sample ID: Lab Blank

Lab ID#: 1311468B-06C

MODIFIED METHOD TO-15 GC/MS FULL SCAN

File Name:	14112607e	Date of Collection:	NA
Dil. Factor:	1.00	Date of Analysis:	11/26/13 04:46 PM

Compound	Rpt. Limit (ppbv)	Amount (ppbv)	Rpt. Limit (ug/m3)	Amount (ug/m3)
C5-C6 Aliphatic Hydrocarbons (ref. to Pentane + Hexane)	50	Not Detected	160	Not Detected
>C6-C8 Aliphatic Hydrocarbons (ref. to Heptane)	50	Not Detected	200	Not Detected
>C8-C10 Aliphatic Hydrocarbons (ref. to Decane)	50	Not Detected	290	Not Detected
>C10-C12 Aliphatic Hydrocarbons (ref. to Dodecane)	50	Not Detected	350	Not Detected

Container Type: NA - Not Applicable



Air Toxics

Client Sample ID: Lab Blank

Lab ID#: 1311468B-06D

MODIFIED METHOD TO-15 GC/MS FULL SCAN

File Name:	14112607f	Date of Collection:	NA
Dil. Factor:	1.00	Date of Analysis:	11/26/13 04:46 PM

Compound	Rpt. Limit (ppbv)	Amount (ppbv)	Rpt. Limit (ug/m3)	Amount (ug/m3)
>C8-C10 Aromatic Hydrocarbons (ref. to 1,2,3-TMB)	50	Not Detected	240	Not Detected
>C10-C12 Aromatic Hydrocarbons (ref. to 1,2,4,5-TMB)	50	Not Detected	270	Not Detected

Container Type: NA - Not Applicable



Air Toxics

Client Sample ID: CCV

Lab ID#: 1311468B-07A

MODIFIED METHOD TO-15 GC/MS FULL SCAN

File Name:	3112507a	Date of Collection: NA
Dil. Factor:	1.00	Date of Analysis: 11/26/13 07:09 AM

Compound	%Recovery
C5-C6 Aliphatic Hydrocarbons (ref. to Pentane + Hexane)	93
>C6-C8 Aliphatic Hydrocarbons (ref. to Heptane)	87
>C8-C10 Aliphatic Hydrocarbons (ref. to Decane)	92
>C10-C12 Aliphatic Hydrocarbons (ref. to Dodecane)	94

Container Type: NA - Not Applicable



Air Toxics

Client Sample ID: CCV

Lab ID#: 1311468B-07B

MODIFIED METHOD TO-15 GC/MS FULL SCAN

File Name:	3112507c	Date of Collection: NA
Dil. Factor:	1.00	Date of Analysis: 11/26/13 07:09 AM

Compound	%Recovery
>C8-C10 Aromatic Hydrocarbons (ref. to 1,2,3-TMB)	87
>C10-C12 Aromatic Hydrocarbons (ref. to 1,2,4,5-TMB)	93

Container Type: NA - Not Applicable



Air Toxics

Client Sample ID: CCV

Lab ID#: 1311468B-07C

MODIFIED METHOD TO-15 GC/MS FULL SCAN

File Name:	14112606a	Date of Collection: NA
Dil. Factor:	1.00	Date of Analysis: 11/26/13 04:11 PM

Compound	%Recovery
C5-C6 Aliphatic Hydrocarbons (ref. to Pentane + Hexane)	87
>C6-C8 Aliphatic Hydrocarbons (ref. to Heptane)	76
>C8-C10 Aliphatic Hydrocarbons (ref. to Decane)	85
>C10-C12 Aliphatic Hydrocarbons (ref. to Dodecane)	87

Container Type: NA - Not Applicable



Air Toxics

Client Sample ID: CCV

Lab ID#: 1311468B-07D

MODIFIED METHOD TO-15 GC/MS FULL SCAN

File Name:	14112606c	Date of Collection: NA
Dil. Factor:	1.00	Date of Analysis: 11/26/13 04:11 PM

Compound	%Recovery
>C8-C10 Aromatic Hydrocarbons (ref. to 1,2,3-TMB)	77
>C10-C12 Aromatic Hydrocarbons (ref. to 1,2,4,5-TMB)	72

Container Type: NA - Not Applicable

11/26/2013
Mr. Eric Epple
Arcadis U.S., Inc.
1100 Olive Way
Ste 800
Seattle WA 98101

Project Name: Edmonds Terminal
Project #: B0045362.0004
Workorder #: 1311468C

Dear Mr. Eric Epple

The following report includes the data for the above referenced project for sample(s) received on 11/25/2013 at Air Toxics Ltd.

The data and associated QC analyzed by Modified ASTM D-1946 are compliant with the project requirements or laboratory criteria with the exception of the deviations noted in the attached case narrative.

Thank you for choosing Air Toxics Ltd. for your air analysis needs. Air Toxics Ltd. is committed to providing accurate data of the highest quality. Please feel free to contact the Project Manager: Kelly Buettner at 916-985-1000 if you have any questions regarding the data in this report.

Regards,



Kelly Buettner
Project Manager

WORK ORDER #: 1311468C

Work Order Summary

CLIENT:	Mr. Eric Epple Arcadis U.S., Inc. 1100 Olive Way Ste 800 Seattle, WA 98101	BILL TO:	Accounts Payable Arcadis U.S., Inc. 630 Plaza Drive Suite 600 Highlands Ranch, CO 80129
PHONE:	206-726-4728	P.O. #	B0045362.0004
FAX:	206-325-8218	PROJECT #	B0045362.0004 Edmonds Terminal
DATE RECEIVED:	11/25/2013	CONTACT:	Kelly Buettner
DATE COMPLETED:	11/26/2013		

<u>FRACTION #</u>	<u>NAME</u>	<u>TEST</u>	<u>RECEIPT VAC./PRES.</u>	<u>FINAL PRESSURE</u>
01A	VP-1	Modified ASTM D-1946	1.8 "Hg	15 psi
02A	VP-2	Modified ASTM D-1946	3.1 "Hg	15.1 psi
03A	VP-3	Modified ASTM D-1946	1.2 "Hg	14.9 psi
04A	BD-1	Modified ASTM D-1946	1.4 "Hg	15 psi
05A	Equipment Blank	Modified ASTM D-1946	1 "Hg	15.1 psi
06A	Lab Blank	Modified ASTM D-1946	NA	NA
06B	Lab Blank	Modified ASTM D-1946	NA	NA
07A	LCS	Modified ASTM D-1946	NA	NA
07AA	LCSD	Modified ASTM D-1946	NA	NA

CERTIFIED BY: 
 Technical Director

DATE: 11/26/13

Certification numbers: AZ Licensure AZ0775, CA NELAP - 12282CA, NJ NELAP - CA016, NY NELAP - 11291, TX NELAP - T104704434-13-6, UT NELAP CA009332013-4, VA NELAP - 460197, WA NELAP - C935
 Name of Accrediting Agency: NELAP/ORELAP (Oregon Environmental Laboratory Accreditation Program)
 Accreditation number: CA300005, Effective date: 10/18/2013, Expiration date: 10/17/2014.

Eurofins Air Toxics Inc. certifies that the test results contained in this report meet all requirements of the NELAC standards

This report shall not be reproduced, except in full, without the written approval of Eurofins Air Toxics, Inc.

180 BLUE RAVINE ROAD, SUITE B FOLSOM, CA - 9563
 (916) 985-1000 . (800) 985-5955 . FAX (916) 985-1020



LABORATORY NARRATIVE
Modified ASTM D-1946
Arcadis U.S., Inc.
Workorder# 1311468C

Five 1 Liter Summa Canister samples were received on November 25, 2013. The laboratory performed analysis via Modified ASTM Method D-1946 for Methane and fixed gases in air using GC/FID or GC/TCD. The method involves direct injection of 1.0 mL of sample.

On the analytical column employed for this analysis, Oxygen coelutes with Argon. The corresponding peak is quantitated as Oxygen.

Method modifications taken to run these samples are summarized in the table below. Specific project requirements may over-ride the ATL modifications.

<i>Requirement</i>	<i>ASTM D-1946</i>	<i>ATL Modifications</i>
Calibration	A single point calibration is performed using a reference standard closely matching the composition of the unknown.	A 3-point calibration curve is performed. Quantitation is based on a daily calibration standard which may or may not resemble the composition of the associated samples.
Reference Standard	The composition of any reference standard must be known to within 0.01 mol % for any component.	The standards used by ATL are blended to a $\geq 95\%$ accuracy.
Sample Injection Volume	Components whose concentrations are in excess of 5 % should not be analyzed by using sample volumes greater than 0.5 mL.	The sample container is connected directly to a fixed volume sample loop of 1.0 mL on the GC. Linear range is defined by the calibration curve. Bags are loaded by vacuum.
Normalization	Normalize the mole percent values by multiplying each value by 100 and dividing by the sum of the original values. The sum of the original values should not differ from 100% by more than 1.0%.	Results are not normalized. The sum of the reported values can differ from 100% by as much as 15%, either due to analytical variability or an unusual sample matrix.
Precision	Precision requirements established at each concentration level.	Duplicates should agree within 25% RPD for detections $> 5 X$'s the RL.

Receiving Notes

There were no receiving discrepancies.

Analytical Notes

There were no analytical discrepancies.

Definition of Data Qualifying Flags

Seven qualifiers may have been used on the data analysis sheets and indicate as follows:

B - Compound present in laboratory blank greater than reporting limit.

J - Estimated value.

E - Exceeds instrument calibration range.

S - Saturated peak.

Q - Exceeds quality control limits.

U - Compound analyzed for but not detected above the detection limit.

M - Reported value may be biased due to apparent matrix interferences.

File extensions may have been used on the data analysis sheets and indicates as follows:

a-File was requantified

b-File was quantified by a second column and detector

r1-File was requantified for the purpose of reissue

Summary of Detected Compounds
NATURAL GAS ANALYSIS BY MODIFIED ASTM D-1946

Client Sample ID: VP-1

Lab ID#: 1311468C-01A

Compound	Rpt. Limit (%)	Amount (%)
Oxygen	0.22	2.6
Methane	0.00022	29
Carbon Dioxide	0.022	11

Client Sample ID: VP-2

Lab ID#: 1311468C-02A

Compound	Rpt. Limit (%)	Amount (%)
Oxygen	0.23	1.6
Methane	0.00023	2.6
Carbon Dioxide	0.023	12

Client Sample ID: VP-3

Lab ID#: 1311468C-03A

Compound	Rpt. Limit (%)	Amount (%)
Oxygen	0.21	1.3
Methane	0.00021	23
Carbon Dioxide	0.021	11

Client Sample ID: BD-1

Lab ID#: 1311468C-04A

Compound	Rpt. Limit (%)	Amount (%)
Oxygen	0.21	4.0
Methane	0.00021	2.3
Carbon Dioxide	0.021	10

Client Sample ID: Equipment Blank

Lab ID#: 1311468C-05A

Compound	Rpt. Limit (%)	Amount (%)
-----------------	-----------------------	-------------------

Summary of Detected Compounds
NATURAL GAS ANALYSIS BY MODIFIED ASTM D-1946

Client Sample ID: Equipment Blank

Lab ID#: 1311468C-05A

Compound	Rpt. Limit (%)	Amount (%)
Oxygen	0.21	2.5



Air Toxics

Client Sample ID: VP-1

Lab ID#: 1311468C-01A

NATURAL GAS ANALYSIS BY MODIFIED ASTM D-1946

File Name:	10112521	Date of Collection:	11/21/13 12:44:00 P
Dil. Factor:	2.15	Date of Analysis:	11/25/13 06:30 PM

Compound	Rpt. Limit (%)	Amount (%)
Oxygen	0.22	2.6
Methane	0.00022	29
Carbon Dioxide	0.022	11
Helium	0.11	Not Detected

Container Type: 1 Liter Summa Canister



Air Toxics

Client Sample ID: VP-2

Lab ID#: 1311468C-02A

NATURAL GAS ANALYSIS BY MODIFIED ASTM D-1946

File Name:	10112520	Date of Collection:	11/21/13 11:30:00 A
Dil. Factor:	2.26	Date of Analysis:	11/25/13 06:01 PM

Compound	Rpt. Limit (%)	Amount (%)
Oxygen	0.23	1.6
Methane	0.00023	2.6
Carbon Dioxide	0.023	12
Helium	0.11	Not Detected

Container Type: 1 Liter Summa Canister



Air Toxics

Client Sample ID: VP-3

Lab ID#: 1311468C-03A

NATURAL GAS ANALYSIS BY MODIFIED ASTM D-1946

File Name:	10112522	Date of Collection:	11/21/13 10:10:00 A
Dil. Factor:	2.10	Date of Analysis:	11/25/13 06:58 PM

Compound	Rpt. Limit (%)	Amount (%)
Oxygen	0.21	1.3
Methane	0.00021	23
Carbon Dioxide	0.021	11
Helium	0.10	Not Detected

Container Type: 1 Liter Summa Canister



Air Toxics

Client Sample ID: BD-1

Lab ID#: 1311468C-04A

NATURAL GAS ANALYSIS BY MODIFIED ASTM D-1946

File Name:	10112523	Date of Collection:	11/21/13
Dil. Factor:	2.12	Date of Analysis:	11/25/13 07:47 PM

Compound	Rpt. Limit (%)	Amount (%)
Oxygen	0.21	4.0
Methane	0.00021	2.3
Carbon Dioxide	0.021	10
Helium	0.11	Not Detected

Container Type: 1 Liter Summa Canister



Air Toxics

Client Sample ID: Equipment Blank

Lab ID#: 1311468C-05A

NATURAL GAS ANALYSIS BY MODIFIED ASTM D-1946

File Name:	10112524	Date of Collection:	11/21/13 1:08:00 PM
Dil. Factor:	2.10	Date of Analysis:	11/25/13 08:12 PM

Compound	Rpt. Limit (%)	Amount (%)
Oxygen	0.21	2.5
Methane	0.00021	Not Detected
Carbon Dioxide	0.021	Not Detected
Helium	0.10	Not Detected

Container Type: 1 Liter Summa Canister



Air Toxics

Client Sample ID: Lab Blank

Lab ID#: 1311468C-06A

NATURAL GAS ANALYSIS BY MODIFIED ASTM D-1946

File Name:	10112505	Date of Collection:	NA
Dil. Factor:	1.00	Date of Analysis:	11/25/13 10:30 AM

Compound	Rpt. Limit (%)	Amount (%)
Oxygen	0.10	Not Detected
Methane	0.00010	Not Detected
Carbon Dioxide	0.010	Not Detected

Container Type: NA - Not Applicable



Air Toxics

Client Sample ID: Lab Blank

Lab ID#: 1311468C-06B

NATURAL GAS ANALYSIS BY MODIFIED ASTM D-1946

File Name:	10112506c	Date of Collection:	NA
Dil. Factor:	1.00	Date of Analysis:	11/25/13 10:57 AM

Compound	Rpt. Limit (%)	Amount (%)
Helium	0.050	Not Detected

Container Type: NA - Not Applicable



Air Toxics

Client Sample ID: LCS

Lab ID#: 1311468C-07A

NATURAL GAS ANALYSIS BY MODIFIED ASTM D-1946

File Name:	10112502	Date of Collection: NA
Dil. Factor:	1.00	Date of Analysis: 11/25/13 09:18 AM

Compound	%Recovery	Method Limits
Oxygen	102	85-115
Methane	101	85-115
Carbon Dioxide	100	85-115
Helium	98	85-115

Container Type: NA - Not Applicable



Air Toxics

Client Sample ID: LCSD

Lab ID#: 1311468C-07AA

NATURAL GAS ANALYSIS BY MODIFIED ASTM D-1946

File Name:	10112526	Date of Collection: NA
Dil. Factor:	1.00	Date of Analysis: 11/25/13 09:51 PM

Compound	%Recovery	Method Limits
Oxygen	102	85-115
Methane	101	85-115
Carbon Dioxide	99	85-115
Helium	98	85-115

Container Type: NA - Not Applicable



Appendix D

Applicable or Relevant and
Appropriate Requirements

SUMMARY OF POTENTIALLY APPLICABLE REQUIREMENTS

According to WAC 173-340-360(2), all cleanup actions under the Model Toxics Control Act (MTCA) must comply with applicable state and federal laws. Such laws are defined under the MTCA as including Applicable or Relevant and Appropriate Requirements (ARARs). ARARs for the Lower Yard are discussed below:

Summary of Generally Applicable or Relevant and Appropriate Regulations

Clean Water Act (CWA)

Provisions set forth in the Federal Water Pollution Control Act (FWPCA), commonly referred to as the CWA, require the development of regulations to protect the nation's waters. Requirements of the CWA have been delegated to the State of Washington which has corresponding rules and regulations, encompassing all of those stated in the CWA. Therefore, potential discharges to surface water will be managed under the State program.

Resource Conservation and Recovery Act (RCRA)

Investigation –derived waste (IDW), soil, water or other substances removed from the site during the implementation of remedial activities will be handled per RCRA regulations and implemented according to WAC 173-303.

The Endangered Species Act

The only threatened or endangered species identified in the vicinity of the Terminal is the bald eagle. Bald eagles are frequently observed in flight over the Lower Yard, and they may perch in trees of the Upper Yard. Implementation of the remedial action in conformance with MTCA will result in the protection of wildlife, including any threatened and endangered species.

Migratory Bird Treaty Act

A great blue heron colony is found in the southeast Lower Yard. In 2007, testing was conducted to evaluate the level of disturbance in the areas adjacent to the great blue heron nests. The testing determined that the heron would not be disturbed by site remediation activities conducted greater than 150 feet away from the nests. Site remedial activities will not be conducted less than 150 feet from the colony. Additionally, implementation of the remedial action in conformance with MTCA, will provide that wildlife, including migratory birds, will be protected.

The Safe Drinking Water Act

The groundwater CULs for the Lower Yard were established based on protection of surface water, since a determination was made that the groundwater beneath the Lower Yard is non-potable.

Natural Resource Damages

Remedial design and implementation will establish means and methods to ensure that the remedial action minimizes risks that could potentially damage natural resources, such as surface-water resources, groundwater resources, air resources, geologic resources, and biological resources. Damages to natural resource caused by remedial action implementation will be avoided, and are not expected to occur.

U.S. Department of Transportation Hazardous Materials Regulations

The U.S. Department of Transportation has published regulations, including communications and emergency response requirements, shipping, and packaging requirements (49 CFR 107, 171)), that govern the transportation of hazardous materials to or from the site. Hazardous waste generated at the site will be appropriately characterized to determine package, transportation and transportation requirements prior to implementing remedial action.

National Ambient Air Quality Standards Attainment Area

Air emissions generated by the remedial implementation at the site are subject to applicable air-quality standards in order to control or prevent the emission of air contaminants. The applicable pollutants at the site would be particulate matter (dust) and carbon monoxide. Degradation of ambient air quality caused by remedial action implementation at the site will be avoided, and is not expected to occur.

Occupational Safety and Health Administration (OSHA)

Site activities will be conducted in a manner compliant with OSHA standards and regulations (29 CFR 1910).

Model Toxics Control Act

All elements of the remedial design and site activities will occur in accordance with MTCA statutes and regulations.

National Pollutant Discharge Elimination System Stormwater Permit Program

A NPDES permit modification will be needed for discharge of treated water to Willow Creek. Effluent limitations, sampling parameters and discharge quality standards will be defined in this permit, which will affect the treatment technologies used in the treatment system. Consequently, design and operation of the system will conform to applicable regulations.

Air Quality Standards

During remedial implementation, engineering controls will be necessary to control particulate emissions. Air testing may be required to show that emissions meet the substantive requirements of applicable air quality permits and rules, as administered by the Puget Sound Clean Air Agency.

Noise Regulations

Site activities will be conducted at appropriate noise levels, according to the City of Edmonds Municipal Code. Noise production during remedial activities may limit operating hours of project work.

State Environmental Policy Act

The State Environmental Policy Act (SEPA) provides the framework for agencies to consider the environmental consequences of a proposed land use action. SEPA requires the preparation of an environmental checklist and review of the potential environmental impacts and mitigation measures used to protect the environment. A SEPA checklist will be prepared with the permitting of the remedial action to be conducted at the site.

Spill Prevention, Preparedness, and Response

A spill prevention, control, and countermeasures plan will be developed for the storage and handling of these materials. This will include potential groundwater treatment system facilities and heavy equipment used onsite, as well as any stored materials.

Minimum Standards for Construction and Maintenance of Wells, Regulation and Licensing of Well Contractors and Operators

Resource protection wells will be decommissioned, constructed and maintained according to the appropriate regulations

Washington Industrial Safety and Health Act

Site activities will be conducted in a manner compliant with Washington Industrial Safety and Health Act (WISHA) standards and regulations.

City of Edmonds Permits

The City of Edmonds requires permits for grading, excavation, and fill activities. All required permits needed from the City of Edmonds will be obtained during the design phase of the remedial action and will apply to all of the remedial activities.



Appendix E

2007 TEE

TERRESTRIAL ECOLOGICAL EVALUATION

INTRODUCTION

This appendix presents the terrestrial ecological evaluation (TEE) for the lower yard of the Unocal Edmonds Bulk Fuel Terminal (Terminal), as required by WAC 173-340-7490. It is formatted consistent with the documentation forms provided by the Department of Ecology (Ecology) on its interactive website.

Site background and history are summarized in Section 2 of this report. Soils on site are mainly contaminated with petroleum, primarily in the diesel and oil range, from fuel storage and transfer activities. Union Oil Company (Union Oil) has performed interim actions to remove free product and soils in the areas of highest soil contamination. The completed interim actions, the planned interim action, and the nature of the future development of the lower yard minimize potential exposures to terrestrial receptors by reducing contaminant levels and controlling exposure pathways. Substantial amounts of contaminated soils have been removed, significantly reducing both the spatial extent of contamination and the concentrations of remaining contaminants.

Soils containing significant TPH concentrations remain in areas of the lower yard. Union Oil intends to complete remediation of the lower yard prior to redevelopment as a multi-modal transportation facility. After development, a large portion of the site will be covered with buildings and pavement. In covered areas, terrestrial receptors will be unable to contact soil contaminants.

RI/FS activities included sediment sampling for chemical analyses and bioassays in Willow Creek, adjacent to the lower yard. The RI also included whole effluent toxicity (WET) testing of groundwater beneath the lower yard. These data are discussed in Section 5 of this report. This appendix focuses on ecological issues related to the terrestrial environment only.

Environmental studies of the Edmonds Marsh, which is located on the opposite side of Willow Creek from the lower yard, were conducted in conjunction with the Final Environmental Impact Statement (EIS) conducted for the SR104 Edmonds Crossing Project (CH₂M Hill, 2004). Information from these studies was used in this TEE.

PRIMARY EXCLUSIONS

An answer of "Yes" to any one question in this section excludes the site from further TEE [WAC 173-340-7491(1)].

1a) Will soil contamination be located at least 6 feet beneath the ground surface and less than 15 feet [WAC 173-340-7491(1)(a)]?

No. Detectable concentrations of TPH will likely be present within 6 feet of ground surface following remediation.

1b) Will soil contamination be located at least 15 feet beneath the ground surface [WAC 173-340-7491(1)(a)]?

No. As noted above, detectable concentrations of TPH will likely be present within 15 feet of ground surface following remediation.

1c) Will soil contamination be located below the conditional point of compliance [WAC 173-340-7491(1)(a)]?

No. Union Oil does not plan to propose a conditional point of compliance.

2) Will soil contamination be covered by buildings, paved roads, pavement, or other physical barriers that will prevent plants or wildlife from being exposed [WAC 173-340-7491(1)(b)]?

No. After redevelopment as a multi-modal transportation terminal, there may be some uncapped areas that contain detectable concentrations of the IHSs.

3a) Is there less than 1.5 acres of contiguous undeveloped land on the site, or within 500 feet of any area of the site affected by hazardous substances (other than those substances listed in WAC 173-340-7491(1)(c)(ii)) [WAC 173-340-7491(1)(c)(i)]?

No. There are more than 1.5 acres of contiguous undeveloped land in a wooded area adjacent to the southwest portion of the lower yard.

3b) Is there less than 0.25 acres of contiguous undeveloped land on or within 500 feet of any area of the site affected by hazardous substances listed in WAC 173-340-7491(1)(c)(ii) [WAC 173-340-7491(1)(c)(ii)]?

Not applicable. The site is not contaminated with any of the listed substances.

4) Are concentrations of hazardous substances in the soil less than or equal to natural background concentrations of those substances at the point of compliance [WAC 173-340-7491(1)(d)]?

No. Ecology does not recognize natural background concentrations of petroleum hydrocarbons.

EXCLUSIONS CONCLUSION: The lower yard does not qualify for exclusion from the TEE.

SIMPLIFIED OR SITE-SPECIFIC EVALUATION

An answer of “Yes” to any one question below means the lower yard is required to undergo a site-specific TEE [WAC 173-340-7491(2)]. Otherwise, a simplified evaluation is allowed.

1) Is the site located on or directly adjacent to an area where management or land use plans will maintain or restore native or semi-native vegetation [WAC 173-340-7491(2)(a)(i)]?

Yes. Edmonds Marsh is directly adjacent to the eastern portion of the lower yard. According to the Final EIS for the Edmonds Crossing project [CH₂M Hill, 2004 (p. 3-41)], Edmonds Marsh has been rated by the City of Edmonds as a Category 1 (high quality) wetland based on its uniqueness, large size, and habitat for a state monitor species (great blue heron). It is designated by the city as a Wildlife Sanctuary on the City of Edmonds Environmentally Sensitive Areas map and as a Priority Habitat in the WDFW Priority Habitat and Species database. Category I wetlands are considered the most valuable, and their disturbance is rarely permitted.

2a) Is the site used by a threatened or endangered species [WAC 173-340-7491(2)(a)(ii)]? For animals, “used” means that individuals of a species have been observed to live, feed or breed at the site. For plants, “used” means that a plant species grows at the site or has been found growing at the site.

No. A Wildlife Habitat Study was performed in 1996 as part of the remedial investigation of the Terminal (Adolfson, 1996). Specific to threatened and endangered species, the study findings were as follows:

Bald eagles are reported as nesting approximately one mile south of the Terminal. Bald eagle nests are not known to exist on the Terminal property or within one mile of the property boundary. During field surveys in 1995, bald eagles were observed perched in large deciduous trees located along the bluff to the south of the Terminal’s pier.

No other threatened or endangered animal species were identified. Although bald eagles have been removed from the endangered list, they are still listed as threatened (www.wa.gov/wdfw/wlm/diversty/soc/threaten.htm). Observations by former site personnel indicate that bald eagle do not live at the Terminal, nor have bald eagles been seen perching in trees at the Terminal. As bald eagles are primarily fish eaters, the lower yard does not provide suitable foraging habitat. Bald eagles are seen in flight above the Terminal, but this behavior does not meet the definition of “use” (live, feed, or breed).

The Washington Department of Fish and Wildlife (WDFW) was contacted in the spring of 2002 for additional information. The Priority Habitats and Species Database and Wildlife Heritage Database show the Terminal to be in an area where priority habitats and species are unknown, or the area was not mapped. The area to the south of the Terminal is identified as a bald eagle use area (breeding occurrence).

2b) Is the site used by a wildlife species classified by the Washington State Department of Fish and Wildlife as a “priority species” or “species of concern” under Title 77 RCW [WAC 173-340-7491(2)(a)(ii)]?

No. The WDFW database (www.wa.gov/wdfw/wlm/diversty/soc/threaten.htm) was searched for mammalian, avian, reptilian, and amphibian species listed as expected to occur at the Terminal per the Wildlife Habitat Study. None of the species identified in the Wildlife Habitat Study is listed in the WDFW database as a “priority species” or “species of concern.”

2c) Is the site used by a plant species classified by the Washington State Department of Natural Resources Natural Heritage Program as “endangered,” “threatened,” or “sensitive” under Title 79 RCW [WAC 173-340-7491(2)(a)(ii)]?

No. A review of the Washington State Department of Natural Resources’ Natural Heritage Information System (www.wa.gov/htdocs/fr/nhp/refdesk/fsrefix.htm) was performed as part of the 1996 Wildlife Habitat Study. There are no records of significant natural features, rare plants, high quality native wetlands, or high quality native plant communities within the vicinity of the project area.

Additional studies have been performed for purposes of the Edmonds Crossing EIS. No endangered, threatened, or sensitive species were identified in studies performed in 2000 and 2001 (personal communication between Cathy Conolly of Adolfson Associates and Linda Dawson of Maul Foster & Alongi, Inc. on November 30, 2001).

3) Is the area of contamination located on a property that contains at least 10 acres of native vegetation within 500 feet of the area of contamination [WAC 173-340-7491(2)(a)(iii)]?

No. The lower yard (23 acres in area) was an active industrial site that has recently been subject to intensive remedial activity including excavation, backfilling, and grading, and it contains limited vegetation. A small area (approximately 2 acres) located in the southeast corner of the lower yard contains native vegetation. The lower yard will be redeveloped as a multi-modal transportation facility, so it will be primarily covered by buildings and pavement. At present, the lower yard offers limited, disturbed terrestrial habitat. The sparse vegetative cover, low species diversity, and amount of human disturbance in this area limit wildlife use of this habitat [Adolfson Associates, Inc., 1996 (p. 9)].

4) Has the department determined that the site may present a risk to significant wildlife populations [WAC 173-340-7491(2)(a)(iv)]?

No. Ecology has not determined that the lower yard may present a significant risk to wildlife populations.

SIMPLIFIED OR SITE-SPECIFIC EVALUATION CONCLUSION: A site-specific TEE is required because of the site’s location next to Edmonds Marsh.

SIMPLIFIED EVALUATION

A simplified TEE is not allowed because a site-specific evaluation is required.

SITE-SPECIFIC EVALUATION

A site-specific TEE consists of two elements: problem formulation and the actual evaluation. After reviewing the problem formulation, Ecology may determine that additional evaluation is not necessary [WAC 173-340-7493(1)(d)].

Problem Formulation

Problem formulation involves identifying the following components of the site-specific TEE:

- Chemicals of ecological concern
- Exposure pathways
- Terrestrial ecological receptors of concern
- Toxicological assessment

The indicator hazardous substances (IHSs) chosen for the TEE are the following (see Section 5.1.3 of this report):

- GRO
- DRO
- HO
- Benzene
- CPAHs
- Arsenic

Following remediation, if the maximum or the upper 95 percent confidence limit concentrations of the IHSs do not exceed the ecological indicator concentrations in MTCA Table 749-3, they may be eliminated from further consideration [WAC 173-340-7493(2)(a)(i)]. Since the site will be used for commercial purposes, only the values in the wildlife column of the table are applicable [WAC 173-340-7493(2)(a)(i)]. The ecological indicator concentrations are 5,000 mg/kg for GRO, 6,000 mg/kg for DRO, 12 mg/kg for cPAHs (benzo(a)pyrene is used as a surrogate), and 132 mg/kg for arsenic in unsaturated soil. There are no table values for HO and benzene.

The petroleum indicator concentrations note that soil concentrations may not exceed residual saturation values. However, the TPH cleanup level (CUL) for the site (2,975 mg/kg; based on direct contact) exceeds the default residual saturation concentration. This higher CUL can be applied because an empirical demonstration (free product does not occur on the groundwater) will be used to show that post-remediation soil concentrations do not exceed residual saturation. The residual saturation requirements will be met at the conclusion of the remediation.

Institutional controls, in the form of deed restrictions, will be used to ensure that any soils exceeding the ecological indicator soil concentrations are capped, that the caps are maintained, and that if the coverings are disturbed, contaminated soils are handled appropriately [WAC 173-340-7493(2)(a)(ii)]. This will ensure there are no complete exposure pathways to soil concentrations of IHSs exceeding the ecological indicator soil concentrations. If there are no complete exposure pathways, no further evaluation is necessary [WAC 173-340-7493(2)(a)(ii)].

The combination of remedial actions, planned development, and institutional controls will minimize wildlife exposure to site-related contaminants. Evaluation of the first two components of problem formulation finds that additional evaluation is not necessary. Capping the soil with IHS concentrations exceeding those listed in MTCA Table 749-3 (wildlife column only) will allow the site-specific TEE to be ended.



Appendix F

Sampling and Analysis Plan

**Chevron Environmental Management
Company**

Sampling and Analysis Plan

Former Unocal Edmonds Bulk Fuel Terminal
Edmonds, Washington

May 29, 2015

1. Introduction	1
1.1 Purpose and Objectives	1
1.2 Document Organization	1
1.3 Roles and Responsibilities	1
2. Field Sampling Plan	2
2.1 Scope of Work	2
2.2 Sampling Objectives	3
2.3 Sampling Methodology	3
2.3.1 Utility Locate	3
2.3.2 DB-2 Excavation Activities	3
2.3.2.1 Stockpile Characterization Sampling	3
2.3.2.2 NPDES Construction Permit Sampling	6
2.3.2.3 Confirmation Soil Sampling	7
2.3.3 Monitoring Well Installation and Borings	8
2.4 Quality Assurance/Quality Control Samples	9
2.5 Sample Nomenclature	9
2.6 Sample Labeling, Handling, and Chain of Custody	10
2.7 Surveying	10
2.8 Equipment Decontamination	11
2.9 Residuals Management	11
3. Quality Assurance Project Plan	11
3.1 Objective	11
3.2 Analytical Method Requirements	11
3.3 Quality Assurance Indicators	12
3.3.1 Completeness	12
3.3.2 Precision	12
3.3.3 Accuracy	13

3.3.4 Sensitivity	13
3.4 Laboratory Quality Control	14
3.4.1 Method Blanks	14
3.4.2 Laboratory Control Samples	14
3.4.3 Surrogate Spikes	14
3.4.4 Laboratory Duplicates	15
3.4.5 Calibration Standards	15
3.5 Field Instruments and Equipment	15
3.6 Laboratory Instruments and Equipment	16
3.7 Assessment and Response Actions	16
3.8 Data Management	16
3.8.1 Field Data Management	17
3.8.2 Analytical Data Management	17
3.9 Sample Designation System	18
3.10 Corrective Action	18
3.11 Laboratory Reports	18
3.12 Data Validation and Verification	18
4. References	19

Tables

Table F - 1 - Analytical Methods, Measurement Criteria, Containers, and Preservation Requirements

Table F - 2 – Detention Basin 2 - Proposed Sample Location Coordinates

Figures

Figure F - 1 – Proposed Monitoring Well Locations

Figure F - 2 – Stockpile Sampling

Figure F - 3 – Detention Basin 2 Proposed Sample Locations

Figure F - 4 – Proposed Monitoring Well Construction Detail

Attachment 1

SOP 1: Surface and Subsurface Soil Sampling Using Manual Methods

SOP 2: Field Equipment Decontamination

SOP 3: Chain-of-Custody, Handling, Packing and Shipping

SOP 4: Photoionization Detector Air Monitoring and Field Screening

SOP 5: Investigation-Derived Waste Handling and Storage

SOP 6: Field Log Book Entries

SOP 7: Monitoring Well Installation

SOP 8: Monitoring Well Development

SOP 9: Soil Drilling and Sample Collection

1. Introduction

On behalf of Chevron Environmental Management Company (Chevron), ARCADIS U.S., Inc. (ARCADIS) has prepared this Sampling and Analysis Plan (SAP) for the Former Union Oil Company of California (Unocal) Edmonds Bulk Fuel Terminal, located at 11720 Unoco Road, Edmonds, Washington (Site). This SAP is an appendix to the Interim Action Work Plan (IAWP) which is being submitted to comply with Agreed Order (AO) No.DE 4460, under which Unocal, a wholly owned indirect subsidiary of Chevron Corporation, has agreed to conduct remedial activities for soil, groundwater, and sediment at the site; monitor groundwater in the Lower Yard; prepare an Interim Action Report; and prepare a draft Cleanup Action Plan (CAP).

1.1 Purpose and Objectives

The purpose of this SAP is to outline the specific procedures for the sampling and compliance monitoring activities described in the IAWP and to identify the quality assurance requirements for the sampling and laboratory analysis in compliance with the Model Toxics Control Act (MTCA) regulations for sampling and analysis plans (WAC 173-340-820).

1.2 Document Organization

This SAP is organized into the following sections:

- Section 1 – Introduction. Describes the scope and purpose of this SAP.
- Section 2 – Field Sampling Plan (FSP). Describes the sampling methodology for the field sampling and monitoring activities associated with the Detention Basin 2 (DB-2) vicinity excavation.
- Section 3 – Quality Assurance Project Plan (QAPP). Describes the quality assurance (QA) procedures for the field activities and laboratory analyses.

1.3 Roles and Responsibilities

Chevron Project Manager – Kim Jolitz: Responsible for overseeing the implementation of this SAP in accordance with the Agreed Order.

ARCADIS Project Manager – Scott Zorn: Responsible for providing technical oversight and reviewing all activities performed to verify that project objectives are met.

Health and Safety Officer – To be determined (TBD): Responsible for overseeing project health and safety issues and implementing corrective actions as needed.

ARCADIS Field Lead – TBD: Responsible for overseeing sampling activities to verify that all field and analytical objectives are in compliance with this SAP.

ARCADIS Field Personnel – TBD: Responsible for implementing the activities described in this SAP.

Ecology-Certified Laboratory – Lancaster Eurofins Laboratory: Responsible for providing the analytical testing specified in this SAP.

2. Field Sampling Plan

2.1 Scope of Work

Alternative 6 as described in the 2014 Proposed Addendum to the Draft Feasibility Study Report (FS Addendum [ARCADIS 2014]) will be implemented. Alternative 6 includes excavation within the vicinity of the DB-2 and installation of a soil and groundwater treatment system using dual-phase extraction (DPE) technology to address impacts remaining near the Washington State Department of Transportation (WSDOT) stormwater line area.

Compliance monitoring associated with DB-2 excavation activities will consist of the following components:

- Stockpile characterization sampling.
- National Pollutant Discharge Elimination System (NPDES) construction permit sampling.
- Confirmation sampling from the bottom and sidewalls of the excavation.

ARCADIS proposes to install three monitoring wells after the DB-2 excavation activities are complete. The proposed monitoring wells will be located in the west, east and north of the DB-2 excavation area, as shown in Figure F-1. These wells will be part of the Compliance Monitoring Plan (CMP) for the DPE System and included in the Long-term Groundwater Monitoring.

Compliance monitoring during and following DPE operation and Long-term Groundwater Monitoring will be described in the CMP and are not discussed in this document.

2.2 Sampling Objectives

The objectives of the sampling activities associated with the DB-2 vicinity excavation are presented below:

- Characterize the stockpiled excavation material as required by the selected waste facility.
- Characterize the wastewater discharge to confirm compliance with the NPDES construction permit.
- Verify that the lateral and vertical extent of the DB-2 excavation are below the soil remediation levels (RELs) or soil cleanup levels (CULs).

2.3 Sampling Methodology

The sampling methodology was developed to collect data that are of sufficient quality to meet the objectives presented in Section 2.1. The sample collection techniques and specific sampling procedures will follow the methods presented in the Standard Operating Procedures (SOPs) provided in Attachment 1.

2.3.1 Utility Locate

A utility locate will be performed prior to all drilling and soil sampling activities. The utility locate will be conducted in accordance with the ARCADIS Utility Location Policy and Procedure. All underground structures and utilities will be located within 50 feet (ft) of the proposed soil excavation and drilling locations.

2.3.2 DB-2 Excavation Activities

2.3.2.1 Stockpile Characterization Sampling

It is not anticipated that excavated soil from areas with remaining impacts will be reused onsite as backfill material. However, the west/southwest border of the DB-2 excavation is adjacent to 2007/2008 remedial excavation areas. To maintain slopes within the DB-2 excavation, a portion of the 2007/2008 backfill will need to be removed.

Excavated soil from the DB-2 vicinity excavation, with the exception of the backfill material from the 2007/2008 excavation activities, will be temporarily stockpiled onsite for characterization sampling to identify appropriate disposal or treatment alternative at the selected offsite waste facility. Characterization sampling will be conducted as required by the selected waste facility.

The backfill material from the 2007/2008 excavation activities will be segregated in separated temporary stockpiles prior to characterization for likely on-Site reuse. The procedure for characterization of these stockpiles are described in the following paragraphs.

The required number of discrete soil samples for each stockpile will be finalized based on the volume of the stockpile according to the following criteria:

Cubic Yards (CY) of Soil per Stockpile	Number of Samples Required per Stockpile
0 to 500	5
501 to 1,000	7
1,001 to 2000	10
>2,000	10 + 1 for each additional 500

To select specific sample locations, four parameters will be established at each stockpile; height (H), length (L), width (W), and depth of sample (D) as shown on Figure F-2. Height will be measured as the height of the stockpile's top surface above the floor of the stockpile, length will be measured as the longest side of the stockpile, width will be measured as the shorter side perpendicular to the length, and depth of sample will be measured down from the randomly-selected point that is generated by using the height, maximum width, and maximum length coordinates. If the randomly generated coordinate does not exist in real space, then another point will be generated. To confirm these sample location procedures cover the entire volume of the stockpile, the excavation stockpiles will be constructed in a roughly rectangular shape. Sampling points will be generated using a random number generator to generate the sampling coordinates. Sampling points will be located in the field to the nearest foot using an engineer's tape.

At each selected sample location, the soil sample will be collected at the randomly identified depth by using a decontaminated stainless steel spoon, trowel, hand auger, shovel or other suitable equipment in accordance with the methodology described in

the SOP for Surface and Subsurface Soil Sampling Using Manual Methods and Field Equipment Decontamination (Attachment 1). All sampling field activity and data will be recorded on field sampling logs using the procedures described in the ARCADIS SOP Field Log Book Entries (Attachment 1). Samples will be labeled, handled and shipped using the procedures described in the ARCADIS SOP for Chain-of-custody, Handling, Packing and Shipping provided (Attachment 1). Stockpile characterization samples will be submitted to Lancaster Eurofins Laboratories of Lancaster, Pennsylvania (Lancaster) for the following analysis:

- Gasoline-range organics (GRO) by Ecology Method NWTPH-Gx.
- Diesel-range organics (DRO) and heavy oil-range organics (HO) by Ecology Method NWYPH-Dx with silica gel cleanup.
- Benzene by U.S. Environmental Protection Agency (USEPA) Method 8021B.

Samples with detectable DRO and/or HO concentrations will also be analyzed for carcinogenic polycyclic aromatic hydrocarbons (cPAHs) by USEPA Method 8270C. Details of the analysis and methodology are provided in Table F-1.

Land's method as provided in the "Statistical guidance for Ecology site managers" publication (Ecology, 1992) will be used to calculate the average concentration of each analyte in the stockpile using a confidence level of 95 percent. Stockpiled soil that meets one or more of the following criteria will be transported offsite to the selected waste facility:

- The 95% upper confidence limit on the mean indicator hazardous substance (IHS) concentration for total petroleum hydrocarbons (TPH) or benzene exceeds the soil RELs.
- The 95% upper confidence limit on the mean IHS concentrations for total cPAHs exceeds the soil CUL.
- 10 percent or more of the samples contain IHS concentrations that exceed the RELs or CUL.
- Any single sample contains an IHS concentration that is equal to or greater than twice the CUL.

Ecology will be consulted if the data are not log-normally distributed and the average IHS concentrations cannot be calculated using the Land's method.

2.3.2.2 NPDES Construction Permit Sampling

As described in the IAWP, a temporary groundwater treatment system will be used during DB-2 excavation activities to treat water collected in the excavation prior to discharge to Detention Basin 1 (DB-1). A NPDES construction permit will be needed for the temporary groundwater treatment system to discharge into DB-1. Samples will be collected at select discharge points as required by the permit. Samples will be collected following the sampling procedures described below.

1. Record site and discharge point identification information on the field sampling log.
2. Using Teflon-lined tubing, place a line from the desired sampling port to a five gallon bucket that will capture purge water. The bucket will be placed on plastic sheeting to prevent any contact with adjacent soils and surfaces.
3. Open sample port valve slowly. Purge water from sample port for approximately 2 to 3 minutes.
4. Once line has been purged, collect water sample in designated laboratory bottles. Samples will be labeled, handled and shipped using the procedures described in the ARCADIS SOP for Chain-of-custody, Handling, Packing and Shipping. All sampling field activity and data will be recorded on field sampling logs using the procedures described in the ARCADIS SOP Field Log Book Entries.
5. Close the sample port valve and remove Teflon tubing from the sampling port. Decontaminate reusable equipment according to the ARCADIS Field Equipment Decontamination SOP.

Samples will be submitted to Lancaster Eurofins Laboratories of Lancaster, Pennsylvania (Lancaster) for analysis. The list of required analytes and respective methodologies for the NPDES permit will be finalized when the permit is issued. Analytes may include the following:

- Benzene, toluene, ethyl benzene and total xylenes (BTEX)
- GRO, DRO, and HO
- Lead and arsenic
- 1-Methylnaphthalene, 2-methylnaphthalene, and naphthalene
- pH, turbidity, and total suspended solids (TSS)
- cPAHs

Details of the analysis and methodology are provided in Table F-1.

2.3.2.3 Confirmation Soil Sampling

Confirmation soil samples will be collected to verify that the lateral and vertical extent of the DB-2 excavation are below the soil RELs or soil CULs presented in the IAWP. Soil samples will be collected according to the methodology presented in the SOP for Surface and Subsurface Soil Sampling Using Manual Methods (Attachment 1).

- An ARCADIS field staff will conduct field screening of excavated soils and soils left in place to help direct excavation activities. Field screening will include visual observation and using a photoionization detector (PID) to measure volatile organic compounds (VOCs) from grab samples collected in the excavation area, according to the ARCADIS Photoionization Detector Air Monitoring and Field Screening SOP, included in Attachment 1. Once field observations indicate that the majority of impacted soils have been excavated from the DB-2 area, confirmation soil samples will be collected from the sidewalls and the base of the excavation for laboratory analysis. Soil sampling will be conducted on a 25-foot grid with one sample collected at each node of the grid. The proposed sample locations for the base of the excavation are shown on Figure F-3 and the coordinates for each sample location are provided in Table F-2. Where possible, these locations will be identified in the field using wooden stakes with labeled flagging or other similar marker to identify each grid node. All sampling field activity and data will be recorded on field sampling logs using the procedures described in the ARCADIS SOP Field Log Book Entries. Sidewall samples will be collected at 25-foot centers along the established gridlines. Sidewall samples will be collected from depths selected based on field observations (e.g. PID readings, appearance, or odor). Each sample will be collected at the depth that exhibits the greatest evidence of constituent of concern. If there is no field evidence of contamination, then the sample will be collected at a depth immediately above the groundwater table. Samples will be labeled, handled and shipped using the procedures described in the ARCADIS SOP for Chain-of-custody, Handling, Packing and Shipping.
- Samples will be submitted to Lancaster for the following analysis:
 - GRO by Ecology Method NWTPH-Gx.
 - DRO and HO by Ecology Method NWTPH-Dx with silica gel cleanup.
 - Benzene by USEPA Method 8021B.

Samples with detectable DRO and/or HO concentrations will also be analyzed for cPAHs by USEPA Method 8270C.

If any of the samples collected from the sidewalls or base of the excavation exceed the soil RELs or CULs, then excavation will continue within that grid cell. The extent of additional excavation required within the impacted cell will be identified based on field screening results (e.g. PID readings, appearance, or odor) and best professional judgment. Excavation and sampling in the area will continue until final confirmation samples are below applicable soil RELs or CULs. Confirmation samples will be submitted on 24 hour turnaround time.

2.3.3 Monitoring Well Installation and Borings

ARCADIS proposes to install three monitoring wells (MW-533 to MW-535) in the west, east and north of the DB-2 excavation area, as shown in Figure F-1.

ARCADIS will oversee the installation of MW-533, MW-534 and MW-535 by a Washington State-licensed driller. The monitoring wells will be advanced to a depth of 13 feet below ground surface (bgs). The initial eight feet will be cleared using an air knife and vacuum truck to reduce the potential for damage to underground improvements. The wells will be advanced using a hollow stem auger rig with eight-inch hollow stem augers and installed according to the ARCADIS Monitoring Well Installation SOP included in Attachment 1.

Soil samples will not be collected since all three wells will be installed in the clean backfill.

The proposed monitoring wells will be installed according to the SOP for Monitoring Well Installation (Attachment). The proposed monitoring wells will be constructed of 2-inch Schedule 40 Polyvinyl Chloride (PVC) pipe with 0.02-inch slotted screen. Based on previous groundwater levels observed at the Site, the screen interval will be set from 3 to 13 feet bgs, however, the screen interval may be altered based on observations during drilling. Sand packs will be constructed of 2/12 silica sand and extend from one foot above the screened interval to the total depth of the well. Each of the monitoring wells will be completed with hydrated bentonite chips to one foot bgs, with flush-mount well monuments set in concrete at the ground surface. The proposed monitoring well construction detail is shown on Figure F-4.

The monitoring wells will be developed as described in the SOP for Monitoring Well Development (Attachment 1). After monitoring well installation activities have been completed, a licensed land surveyor will survey the locations and elevations.

Groundwater samples will be collected later in accordance with the CMP to be submitted under separate cover.

2.4 Quality Assurance/Quality Control Samples

The following quality assurance samples will be collected during implementation of the sampling program.

- One field duplicate sample per 20 field samples collected per medium (e.g., one per 20 soil samples or one per 20 groundwater samples). Field duplicate samples will be sequentially numbered and for the purposes of laboratory analysis and chain-of-custody there will be no identifying markers of duplicate samples.
- One matrix spike/matrix spike duplicate per 20 field samples collected per medium.
- One rinsate blank sample per day on decontaminated, non-dedicated sampling equipment.
- One trip blank per cooler containing samples that will be analyzed for volatile compounds.

2.5 Sample Nomenclature

Samples will be identified with a unique alpha-numeric code that will identify the type of sample and the location where the sample was collected.

The following sample codes will be used:

- Stockpile soil samples will be labeled with the prefix "SP-", the stockpile name, the grid node, and the depth (in feet) into the pile. For example, a stockpile soil sample collected from Stockpile A1, at grid node G3, at a depth of 1 ft would be labeled SP-A1-G3-1.
- Soil confirmation (excavation) samples will be labeled with the prefix "EX-" and will include the excavation area designation (DB2), grid cell location, and depth. Sidewall samples will also include the "SW" after the sample depth. For example, a sidewall sample collected from grid cell A1 at a depth of 5 ft would be labeled EX-DB2-A1-5-SW.
- Groundwater samples will be labeled with the monitoring well designation and date corresponding to the month and year the sample was collected. For

example, a sample collected from MW-401 in December 2014 would be labeled MW-401-1214.

- Quality assurance samples will be given the following labels:
 - Field duplicate samples will be given the prefix “DUP-“ followed by the matrix, and the date the sample was collected. For example, a field duplicate for a soil sample collected on December 1, 2014 would be labeled DUP-SO-120114.
 - Matrix spike and matrix spike duplicate samples will be labeled with the sample ID followed by an “MS” for matrix spike or “MSD” for matrix spike duplicate. For example, a matrix spike sample collected from MW-401 would be labeled MW-401MS.
 - Rinsate blank samples will be given the prefix “RB-“ followed by the date the sample was collected. For example, a rinsate blank sample collected on December 1, 2014 would be labeled RB-120114.
 - Trip blank samples will be given the prefix “TB-“ followed by the date the sample was collected. For example, a trip blank sample collected on December 1, 2014 would be labeled TB-120114.

2.6 Sample Labeling, Handling, and Chain of Custody

Sampling handling and packaging will be in accordance with the procedures outlined in the SOP for Chain-of-Custody, Handling, Packing and Shipping (Attachment 1). All sample containers labels will be completed with the following information:

- Project name and project number
- Sample designation
- Name or initials of the sampler
- Date and time of sample collection

2.7 Surveying

The location of the final soil excavation confirmation samples and the new groundwater monitoring wells, MW-533 to MW-535, will be surveyed by a registered surveyor. The survey will be conducted with a horizontal accuracy of +/- 1 ft and vertical accuracy of +/- 0.01 ft. The surveyor will also survey the horizontal and vertical extent of the final

excavation. Survey data will be reported in the horizontal datum Washington State Plane Coordinate System (NAD 1983) and vertical datum Mean Lower Low Water (MLLW). MLLW is the vertical datum which is used by the City of Edmonds. The surveyor shall provide the conversion from the MLLW datum to the National Geodetic Vertical Datum of 1929 (NGVD29).

2.8 Equipment Decontamination

Equipment decontamination will be performed using the procedures outlined in the SOP for Field Equipment Decontamination. Site personnel will perform decontamination of all equipment prior to removal from the Site and between sample locations.

2.9 Residuals Management

All soil, water, decontamination liquids, personal protective equipment (PPE), and other waste generated during the field sampling activities will be managed in accordance with applicable local, state, and federal requirements. Residuals will be managed in accordance with the procedures outlined in the SOP for Investigation-Derived Waste Handling and Storage (Attachment 1).

Waste profiles will be generated for each waste stream to be transported off site as required by the selected disposal facility. Disposal characterization samples will be collected as needed to meet facility requirements.

3. Quality Assurance Project Plan

3.1 Objective

The objective of this QAPP is to document the planning, implementation, and assessment procedures for the planned compliance monitoring and sampling activities described in the FSP. The QAPP also documents the QA/QC activities that will be performed to confirm that the data collected are of known and acceptable quality.

3.2 Analytical Method Requirements

The analytical methods and procedures are summarized in Table F-2. The method detection limits (MDLs) and QA indicators including accuracy, precision, and completeness are also listed.

3.3 Quality Assurance Indicators

QA indicators are generally defined in terms of six parameters, representativeness, comparability, sensitivity, completeness, precision, and accuracy. Representativeness is the degree to which the sampling data accurately and precisely represent the site conditions. Comparability is the degree of confidence with which one data set can be compared to another.

3.3.1 Completeness

Completeness is defined as a measure of the amount of valid data obtained from the sampling event compared to the total amount that was obtained. Completeness of a field or laboratory data set will be calculated by comparing the number of valid sample results generated to the total number of results generated.

$$\text{Completeness} = \frac{\text{Number of Valid Results}}{\text{Total Number of Results Generated}} \times 100$$

The assessment of completeness will require professional judgment to determine data usability for intended purposes.

3.3.2 Precision

Precision is a measure of the reproducibility of sample results. The goal is to maintain a level of precision consistent with the objectives of the action. To maximize precision, sampling and analytical procedures will be followed. Checks for precision will include the analysis of laboratory duplicates and field duplicates. Checks for field measurement precision will include duplicate field measurements. Field precision is difficult to measure because of temporal variations in field parameters. However, precision will be controlled through the use of experienced field personnel, properly calibrated meters, and duplicate field measurements. Field duplicates will be used to assess precision for the entire measurement system, including sampling, handling, shipping, storage, preparation, and analysis.

Laboratory data precision will be monitored through the use of laboratory duplicate sample analyses.

The precision of data will be measured by calculation of the relative percent difference (RPD) by the following equation:

$$RPD = \frac{|A - B| \times 100}{(A + B)/2}$$

Where:

A = Analytical result from one of two duplicate measurements

B = Analytical result from the second measurement

3.3.3 Accuracy

Accuracy is a measure of how close a measured result is to the true value. Both field and analytical accuracy will be monitored through initial and continuing calibration of instruments. In addition, reference standards, matrix spikes, blank spikes, and surrogate standards will be used to assess the accuracy of the analytical data.

The accuracy of field measurements will be controlled by experienced field personnel, properly calibrated field meters, and adherence to established protocols. The accuracy of field meters will be assessed by review of calibration and maintenance logs. Laboratory accuracy will be assessed through the use of MS, surrogate spikes and laboratory control samples. Where available and appropriate, QA performance standards will be analyzed periodically to assess laboratory accuracy. Accuracy will be calculated in terms of percent recovery as follows:

$$\text{Percent Recovery} = \frac{(A - X) \times 100}{B}$$

Where:

A = Value measured in spiked sample or standard

X = Value measured in original sample

B = True value of amount added to sample or true value of standard

This formula is derived under the assumption of constant accuracy between the original and spiked measurements.

3.3.4 Sensitivity

Sensitivity is a quantitative measurement to determine if the analytical laboratory's procedures/methodologies and their associated method detection limits (MDLs) can satisfy the project requirements as they relate to the project action limits.

3.4 Laboratory Quality Control

Internal laboratory QC checks will be used to monitor data integrity. These checks will include method blanks, laboratory control samples, internal standards, surrogate samples and calibration standards. Laboratory control charts will be used to determine long-term instrument trends.

3.4.1 Method Blanks

Sources of contamination in the analytical process, whether specific analyses or interferences, must be identified, isolated, and corrected. The method blank is useful in identifying possible sources of contamination within the analytical process. For this reason, it is necessary that the method blank be initiated at the beginning of the analytical process and encompass all aspects of the analytical work. As such, the method blank would assist in accounting for any potential contamination attributable to glassware, reagents, instrumentation, or other sources that could affect sample analysis. One method blank will be analyzed with each analytical series associated with no more than 20 samples.

3.4.2 Laboratory Control Samples

Laboratory Control Samples (LCS) are standards of known concentration and are independent in origin from the calibration standards. The intent of LCS analysis is to provide insight into the analytical proficiency within an analytical series. This includes preparation of calibration standards, validity of calibration, sample preparation, instrument set-up, and the premises inherent in quantitation. Reference standards will be analyzed at the frequencies specified within the analytical methods.

3.4.3 Surrogate Spikes

Surrogates are compounds that are unlikely to occur under natural conditions but that have properties similar to the analytes of interest. This type of control is primarily used for organic samples analyzed by GC/MS and GC methods and is added to the samples prior to purging or extraction. The surrogate spike is utilized to provide broader insight into the proficiency and efficiency of an analytical method on a sample-specific basis. This control reflects analytical conditions that may not be attributable to sample matrix.

If surrogate spike recoveries exceed specified QC limits, the analytical results must be evaluated thoroughly in conjunction with other control measures. In the absence of other control measures, the integrity of the data may not be verifiable, and reanalysis of the samples with additional control may be necessary.

Surrogate spike compounds will be selected utilizing the guidance provided in the analytical methods.

3.4.4 Laboratory Duplicates

Laboratory duplicates will be analyzed to assess laboratory precision. Laboratory duplicates are defined as a separate aliquot of an individual sample that is analyzed as a separate sample.

3.4.5 Calibration Standards

Calibration check standards analyzed within a particular analytical series provide insight regarding instrument stability. A calibration check standard will be analyzed at the beginning and end of an analytical series, or periodically throughout a series containing a large number of samples.

In general, calibration check standards will be analyzed after every 12 hours or more frequently, as specified in the applicable analytical method. If results of the calibration check standard exceed specified tolerances, samples analyzed since the last acceptable calibration check standard will be reanalyzed.

3.5 Field Instruments and Equipment

Prior to field sampling, each piece of field equipment will be inspected to confirm that it is operational and calibrated in accordance with the manufacturer's instruction manual or the analytical method used. All meters that require charging or batteries will be fully charged or have fresh batteries. If instrument servicing is required, the maintenance arrangements will be made for timely service. Field instruments will be maintained according to the instructions provided by the manufacturer.

Logbooks will be kept for each field instrument. Logbooks will contain records of operation, maintenance, calibration, and any problems and repairs. Logbooks for each piece of equipment will be maintained in project records.

3.6 Laboratory Instruments and Equipment

Laboratory instrument and equipment documentation procedures include details of any observed problems, corrective measure(s), routine maintenance, and instrument repair (including information regarding the repair and the individual who performed the repair). Preventive maintenance of laboratory equipment generally will follow the guidelines recommended by the manufacturer. A malfunctioning instrument will be repaired immediately by in-house staff or through a service call from the manufacturer. Paperwork associated with service calls and preventative maintenance calls will be kept on file by the laboratory.

The laboratory manager will be responsible for the routine maintenance of instruments used in the particular laboratory. Any routine preventative maintenance carried out is logged into the appropriate logbooks. The frequency of routine maintenance is dictated by the nature of samples being analyzed, the requirements of the method used, and/or the judgment of the laboratory manager.

All major instruments are backed up by comparable (if not equivalent) instrument systems in the event of unscheduled downtime. An inventory of spare parts is also available to minimize equipment/instrument downtime.

3.7 Assessment and Response Actions

Performance and systems audits may be completed in the field and laboratory. Field performance audit summaries will contain an evaluation of field activities to verify that the activities are performed according to established protocols. The observations made during field performance audits and any recommended changes/deviations to the field procedures will be recorded and documented. In addition, systems audits comparing scheduled QA/QC activities with actual QA/QC activities completed will be performed. The audits will be performed periodically as required by the task needs and duration.

3.8 Data Management

The purpose of data management is to confirm that the necessary data are accurate and readily accessible to meet the analytical and reporting objectives of the project. The field activities will include a significant number of samples that require a structured, comprehensive, and efficient program for management of data.

Data management procedures will be employed to efficiently process the information collected, such that the data are readily accessible and accurate.

3.8.1 Field Data Management

Field activities require consistent documentation and accurate record keeping. Complete and accurate record keeping will be maintained, including fieldbooks and chain of custody forms as described in the ARCADIS SOP Field Log Book Entries. Fieldbooks will detail observations and measurements made during the site work. Data will be recorded directly into site-dedicated, bound notebooks, with each page dated and signed. To verify, at a future date, that notebook pages are not missing, each page will be sequentially numbered. Erroneous entries will be corrected by a single line strike out of the original entry, initialing, dating and then documenting the proper information. Certain media sample locations will be surveyed to accurately record their locations. The survey crew will use its own fieldbooks and will supply the sampling location coordinates to ARCADIS.

Chain of custody forms will be used to document and track sample possession from time of collection to the time of disposal. A chain of custody form will accompany each field sample collected, and one copy of the form will be filed in the field office. Field personnel will be briefed on the proper use of the chain of custody procedure.

All field documentation will be scanned and saved to the ARCADIS electronic project folder. Hard copies will be stored in the ARCADIS Seattle, Washington office.

3.8.2 Analytical Data Management

Analytical data packages received from the laboratory will be reviewed and compared against the information on the chain of custody to confirm that the correct analyses were performed for each sample and that results for all samples submitted for analysis were received. Any discrepancies noted will be promptly corrected in coordination with the laboratory.

All data will be housed in a personal computer-based project database. The project database will include pertinent geographical, field, and analytical data. Information that will be used to populate the database will be derived from the surveying of sampling locations, field observations and analytical results. The project database will be backed up on a weekly basis at minimum or whenever major modifications are made. Access to the database will be limited to authorized project personnel.

3.9 Sample Designation System

A concise and easily understandable sample designation system will be used to facilitate sample tracking and sample management. The sample designation system to be employed during the sampling activities will be consistent, yet flexible enough to accommodate unforeseen sampling events or conditions. A combination of letters and numbers will be used to yield a unique sample number for each field sample collected, as outlined in Section 2.5.

3.10 Corrective Action

Corrective actions are required when field or analytical data are not within the objectives specified in this QAPP. Corrective actions include procedures to promptly investigate, document, evaluate, and correct data collection and/or analytical procedures. All corrective actions for situations including analytical or field equipment malfunctions, nonconformance or noncompliance with the QA requirements, or changes to the sampling procedures will be documented with the project records and maintained in the project file. All corrective action procedures must be initiated prior to continuing with the field or analytical procedure.

3.11 Laboratory Reports

The laboratory will maintain QA records related to analyses, QC, and corrective action. This information will be made available upon request. Routine reporting will include documenting all internal QC checks performed for the project.

3.12 Data Validation and Verification

Data validation entails a review of the QC data and the raw data to verify that the laboratory was operating within required limits; the analytical results were correctly transcribed from the instrument read-outs; and which, if any, environmental samples were related to out-of-control QC samples. The objective of data validation is to identify any questionable or invalid laboratory measurements. Data validation reports will be prepared for each sample batch according to the Laboratory Data Validation Guidelines for Evaluating Inorganic Analyses (EPA, 1994a) and Laboratory Data Validation Function Guidelines for Evaluating Organics Analysis (EPA 1994b). Resolution of any issues regarding laboratory performance or deliverables will be handled between the laboratory and the data validator. Data validation reports will be kept electronically in the project file on an ARCADIS server.

4. References

ARCADIS U.S. Inc. 2014. Proposed Addendum to the Draft Feasibility Study Report. Former Unocal Edmonds Bulk Fuel Terminal. August 11, 2014.

USEPA 1999. Contract Laboratory Program National Functional Guidelines for Organic Data Review. EPA 540-R-99-008.

USEPA 2004. Contract Laboratory Program National Functional Guidelines for Inorganic Data Review. EPA 540-R-04-004.

Washington State Department of Ecology 1992. Statistical Guidance for Ecology Site Managers.



Appendix F Tables

Table F-1
Analytical Methods, Measurement Criteria, Containers, and Preservation Requirements

Sampling and Analysis Plan
Former Unocal Edmonds Bulk Fuel Terminal
Edmonds, Washington

Parameter	Analytical Method	Analytical Procedure	Reporting Units	Laboratory MDL	Accuracy	Precision	Completeness	Bottle Type	Preservation	Holding Time
Soil Analysis										
DRO	NWTPH-Dx (with silica gel cleanup)	GC/FID with a silica gel cleanup step (Ecology 1997)	mg/kg	10	61-120%	40	95%	1 x 8-oz glass jar with Teflon®-lined lid	Cool to <6°C	14 days to analysis
HO			mg/kg	25	±50%	50	95%			
GRO	NWTPH-Gx	Purge and trap or direct injection and GC/FID (Ecology 1997)	mg/kg	5	±25%	25	95%	1 x 4-oz glass jar with Teflon®-lined lid	Cool to <6°C	14 days to analysis
Benzene	8021B	GC/PID (EPA 1986)	µg/kg	30	±25%	25	95%	1 x 4-oz glass jar with Teflon®-lined lid	Cool to <6°C	14 days to analysis
cPAHs	8270C	GC/MS with SIM (EPA 1986)	µg/kg	10	46-148%	39	95%	1 x 8-oz glass jar with Teflon®-lined lid	Cool to <6°C	14 days to extraction 40 days to analysis
Groundwater Analysis										
DRO	NWTPH-Dx (with silica gel cleanup)	GC/FID with a silica gel cleanup step (Ecology 1997)	mg/L	0.25	45-119%	35	95%	1 x 1-L amber glass bottle with Teflon®-lined lid	Cool to <6°C	14 days to analysis
HO			mg/L	0.5	±50%	50	95%			
GRO	NWTPH-Gx	Purge and trap or direct injection and GC/FID (Ecology 1997)	mg/L	0.5	±20%	±25%	95%	2 x 40-ml glass vials with Teflon®-lined lid	Cool to <6°C	14 days to analysis (7 days if unpreserved)
Benzene	8021B	GC/PID (EPA 1986)	µg/L	0.5	±20%	±25%	95%	2 x 40-ml glass vials with Teflon®-lined lid	Cool to <6°C; pH to <2 with HCl	14 days to analysis (7 days if unpreserved)
cPAHs (dissolved)	8270C	GC/MS with HVI (EPA 1986)	µg/L	0.01	40-150%	40%	95%	2 x 1-L amber glass bottles with Teflon®-lined lid	Cool to <6°C	7 days to extraction 40 days to analysis
Potential Groundwater Analysis										
Lead	EPA 200.8 rev 5.4	ICP/MS	mg/L	0.000082	85-115%	20%	95%	250 ml plastic or glass bottle	Cool to <6°C; pH to <2 with HNO3	6 months
Arsenic	EPA 200.8 rev 5.4	ICP/MS	mg/L	0.00082	85-115%	20%	95%	250 ml plastic or glass bottle	Cool to <6°C; pH to <2 with HNO3	6 months
Toluene	8021B	GC/PID (EPA 1986)	ug/L	0.2	80-120%	30%	95%	3 x 40 ml glass vials	Cool to <6°C; pH to <2 with HCl	14 days
Ethylbenzene			ug/L	0.2	80-120%	30%	95%	3 x 40 ml glass vials	Cool to <6°C; pH to <2 with HCl	14 days
Xylenes			ug/L	0.2	80-120%	30%	95%	3 x 40 ml glass vials	Cool to <6°C; pH to <2 with HCl	14 days
1-Methylnaphthalene	8270C	GC/MS with SIM (EPA 1986)	ug/L	0.01	75-117%	30%	95%	2 x 250 ml amber glass bottles	Cool to <6 C	7/40 days
2-Methylnaphthalene			ug/L	0.01	68-124%	30%	95%	2 x 250 ml amber glass bottles	Cool to <6 C	7/40 days
Naphthalene			ug/L	0.03	78-117%	30%	95%	2 x 250 ml amber glass bottles	Cool to <6 C	7/40 days
pH	EPA 150.0	EPA 150.1	SU	0.01	95-105%	3%	95%	250 ml plastic or glass bottle	Cool to <6 C	Analyze immediately
turbidity	EPA 180.1 (1993)	EPA 180.1 (1993)	NTU	0.14	90-110%	3%	95%	250 ml plastic or glass bottle	Cool to <6 C	48 hours
total suspended solids	SM 2540 D-1997	2540 D-1997	mg/L	1	91-105%	20%	95%	1500 ml plastic or glass bottle	Cool to <6 C	7 days

Notes:

- Laboratory method detection limits (MDLs) for soil are reported on a dry weight basis.
- Accuracy and precision results may differ from the criteria shown as specified by the analytical method reference.
- Ecology. 1997. Analytical Methods for Petroleum Hydrocarbons. ECY 97-602. June.
- EPA. 1986. Test Methods for Evaluating Soil Waste, Physical/Chemical Methods. SW-846, Third Edition.

Abbreviations:

DRO = diesel range organics
HO = heavy-oil-range organics
GRO = gasoline-range organics
cPAH = carcinogenic polycyclic aromatic hydrocarbons
GC = gas chromatography

FID = flame ionization detection
PID = photo ionization detection
ICPMS = inductively coupled plasma-mass spectrometry
kg = kilograms
mg = milligrams

ug = micrograms
L = liter
SIM = select ion monitoring
HVI = high-volume injection
SM = Standard Method

**Table F-2
Detention Basin 2 - Proposed Sample Location Coordinates**

**Sampling and Analysis Plan
Former Unocal Edmonds Bulk Fuel Terminal
Edmonds, Washington**

Grid Node	X Coordinate	Y Coordinate
A-1	1258081.38	298248.95
A-2	1258099.87	298232.5
A-3	1258115.77	298212.47
A-4	1258133.73	298195.07
A-5	1258152.14	298178.15
A-6	1258173.44	298164.39
A-7	1258191.08	298146.82
A-8	1258209.41	298129.64
B-1	1258064.47	298230.54
B-2	1258082.88	298213.63
B-3	1258101.30	298196.71
B-4	1258119.71	298179.8
B-5	1258138.12	298162.89
B-6	1258156.54	298145.98
B-7	1258174.95	298129.07
B-8	1258193.36	298112.16
C-1	1258193.36	298112.16
C-2	1258065.97	298195.21
C-3	1258084.39	298178.3
C-4	1258102.80	298161.39
C-5	1258121.21	298144.48
C-6	1258139.63	298127.57
C-7	1258158.04	298110.66
C-8	1258176.45	298093.75
D-1	1258030.65	298193.71
D-2	1258049.06	298176.8
D-3	1258067.48	298159.89
D-4	1258085.89	298142.98
D-5	1258104.30	298126.07
D-6	1258122.72	298109.16
D-7	1258141.13	298092.25
D-8	1258159.76	298074.96
E-0	1258001.57	298186.66
E-1	1258013.74	298175.3
E-2	1258032.15	298158.39
E-3	1258050.57	298141.48
E-4	1258068.98	298124.57
E-5	1258087.39	298107.66

Table F-2
Detention Basin 2 - Proposed Sample Location Coordinates

Sampling and Analysis Plan
Former Unocal Edmonds Bulk Fuel Terminal
Edmonds, Washington

Grid Node	X Coordinate	Y Coordinate
E-6	1258105.81	298090.74
E-7	1258124.22	298073.83
F-0	1257985.55	298173.73
F-1	1257996.83	298156.88
F-2	1258015.24	298139.97

Notes:

1. Horizontal datum is Washington State Plane Coordinate System North Zone (NAD 1983)
2. Soil sample locations may be relocated as needed based on field conditions.



Appendix F Figures

CITY:\Reed\DIV\GROUP\Reed\DB\Reed\LD\Opt\PM\Reed\TM\Opt\PIC\Opt\PM\Reed\2102015 140 PM ACAD\VER:18.1\S (LMS TECH) PAGES:18,19 PLOTTED: 2/10/2015 1:40 PM BY: HUTCHINS-WASS, TABITHA
 C:\Users\hutchinsw\My Documents\Projects\2102015 140 PM ACAD\VER:18.1\S (LMS TECH) PAGES:18,19 PLOTTED: 2/10/2015 1:40 PM BY: HUTCHINS-WASS, TABITHA
 PROJECTNAME: --
 XREFS: 45362X02

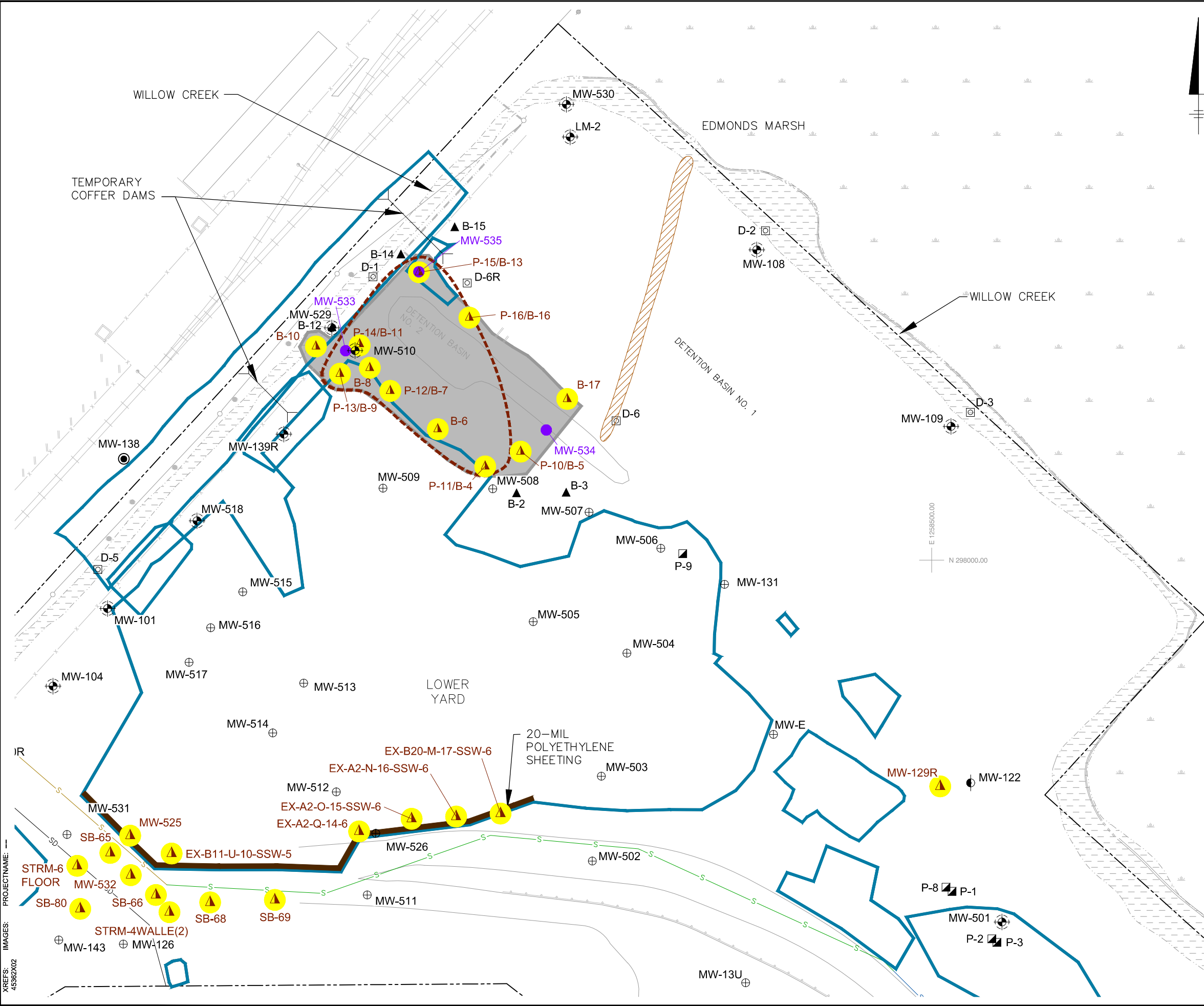

LEGEND:

- ESTIMATED RECOVERABLE LNAPL BOUNDARY
- SOIL SAMPLE COLLECTION LOCATION WITH CONCENTRATIONS OF TPH AND/OR CPAH, EXCEEDING APPLICABLE SITE CULs AND/OR RELs.
- CPAH CARCINOGENIC POLYNUCLEAR AROMATIC HYDROCARBONS, ADJUSTED FOR TOXICITY.
- CUL CLEANUP LEVEL
- REL REMEDIATION LEVEL
- TPH TOTAL PETROLEUM HYDROCARBONS
- MW-203 INTERIOR MONITORING WELL LOCATION AND DESIGNATION
- MW-122 DEEP MONITORING WELL LOCATION AND DESIGNATION
- MW-109 PERIMETER MONITORING WELL LOCATION
- MW-301 BNSF WELLS
- MW-533 PROPOSED MONITORING WELL LOCATION
- P-11 PIEZOMETER
- D-1 STAFF GAUGE
- DPE-12 PROPOSED DUAL PHASE EXTRACTION WELL (DPE)
- 2007/2008 EXCAVATION BOUNDARIES
- PROPERTY BOUNDARY
- WSDOT STORMWATER LINE
- POINT EDWARDS STORM DRAIN LINE
- SOIL BORING
- EXCAVATION BOUNDARY
- TEMPORARY EARTHEN BERM

- NOTES:**
1. 20-MIL POLYETHYLENE SHEETING INSTALLED UPON COMPLETION OF PHASE I EXCAVATION. SHEETING REACHES TO APPROXIMATELY 7.5 FEET ABOVE MEAN SEA LEVEL.
 2. HORIZONTAL DATUM: WASHINGTON STATE COORDINATE SYSTEM NORTH ZONE (NAD 83/98). VERTICAL DATUM: N.A.V.D. 88. UNITS: U.S. SURVEY FEET. HORIZONTAL AND VERTICAL CONTROL ESTABLISHED BY GPS VIA VERTICAL REFERENCE STATION NETWORK (VRSN).
 3. SOUTHEAST PORTION OF WSDOT STORMWATER LINE HAS NOT BEEN SURVEYED.

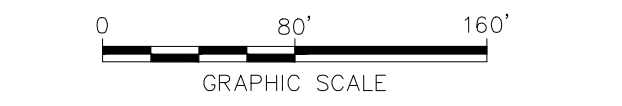

CHEVRON ENVIRONMENTAL MANAGEMENT COMPANY
 FORMER UNOCAL BULK FUEL TERMINAL
 EDMONDS, WASHINGTON
SAMPLING AND ANALYSIS PLAN

**PROPOSED GROUNDWATER
 MONITORING WELL LOCATIONS**

FIGURE
F-1

CITY:\Revd\DIV\GROUP\Revd\DB\Revd\LD\Opt\PM\Revd\TM\Opt\LYR\Opt\ONE\OFF\REF*
C:\Users\hutchins\w\Desktop\AWP\DIV\GIB0045982\F-2.dwg LAYOUT: F-2_SAVED: 2/9/2015 3:31 PM ACADVER: 18.1S (LMS TECH) PAGES: 18 PAGES: 18 PLOTTED: 2/9/2015 3:31 PM BY: HUTCHINS-WASS, TABITHA

XREFS: IMAGES: PROJECTNAME: --

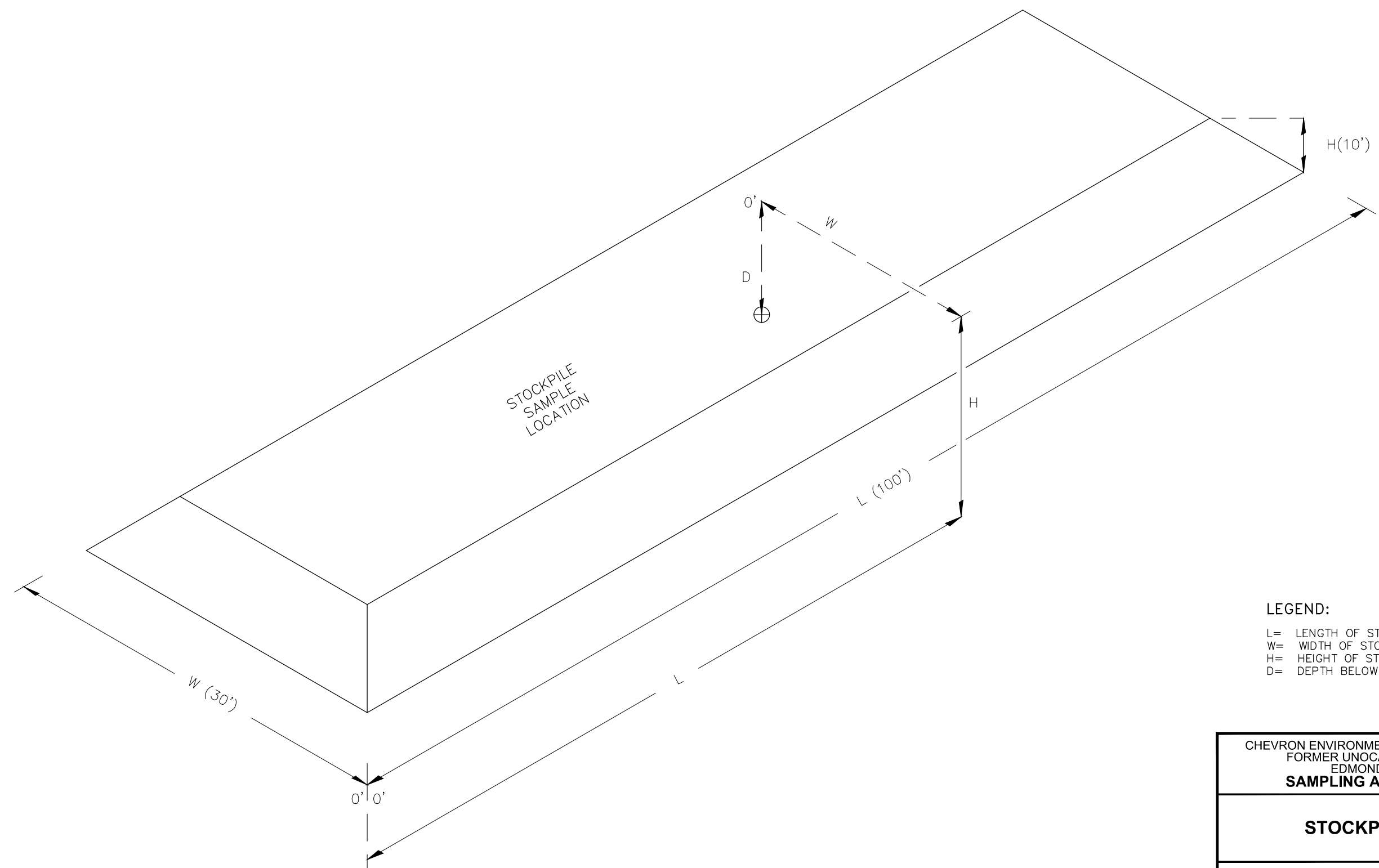

- LEGEND:**
- L= LENGTH OF STOCKPILE
 - W= WIDTH OF STOCKPILE
 - H= HEIGHT OF STOCKPILE
 - D= DEPTH BELOW STOCKPILE SURFACE

CHEVRON ENVIRONMENTAL MANAGEMENT COMPANY FORMER UNOCAL BULK FUEL TERMINAL EDMONDS, WASHINGTON SAMPLING AND ANALYSIS PLAN	
STOCKPILE SAMPLING	
	FIGURE F-2

CITY: ENV, CA DIV/GROUP: ENVCAD DB: ASR PM: TIME TR: LVR: ON="OFF=REF", (FRZ)
 I:\acad\proj\B0045382\A\WP\DWG\B0045382 F-3.dwg LAYOUT: F-3 SAVED: 2/10/2015 12:04 PM ACADVER: 18.1S (LMS TECH) PAGES: 18.1S (LMS TECH) PAGES: 18.1S (LMS TECH) PAGES: 18.1S (LMS TECH) PAGES: 18.1S (LMS TECH) PAGES: 18.1S (LMS TECH)
 XREFS: IMAGES: PROJECTNAME: 45382X02 45382X03

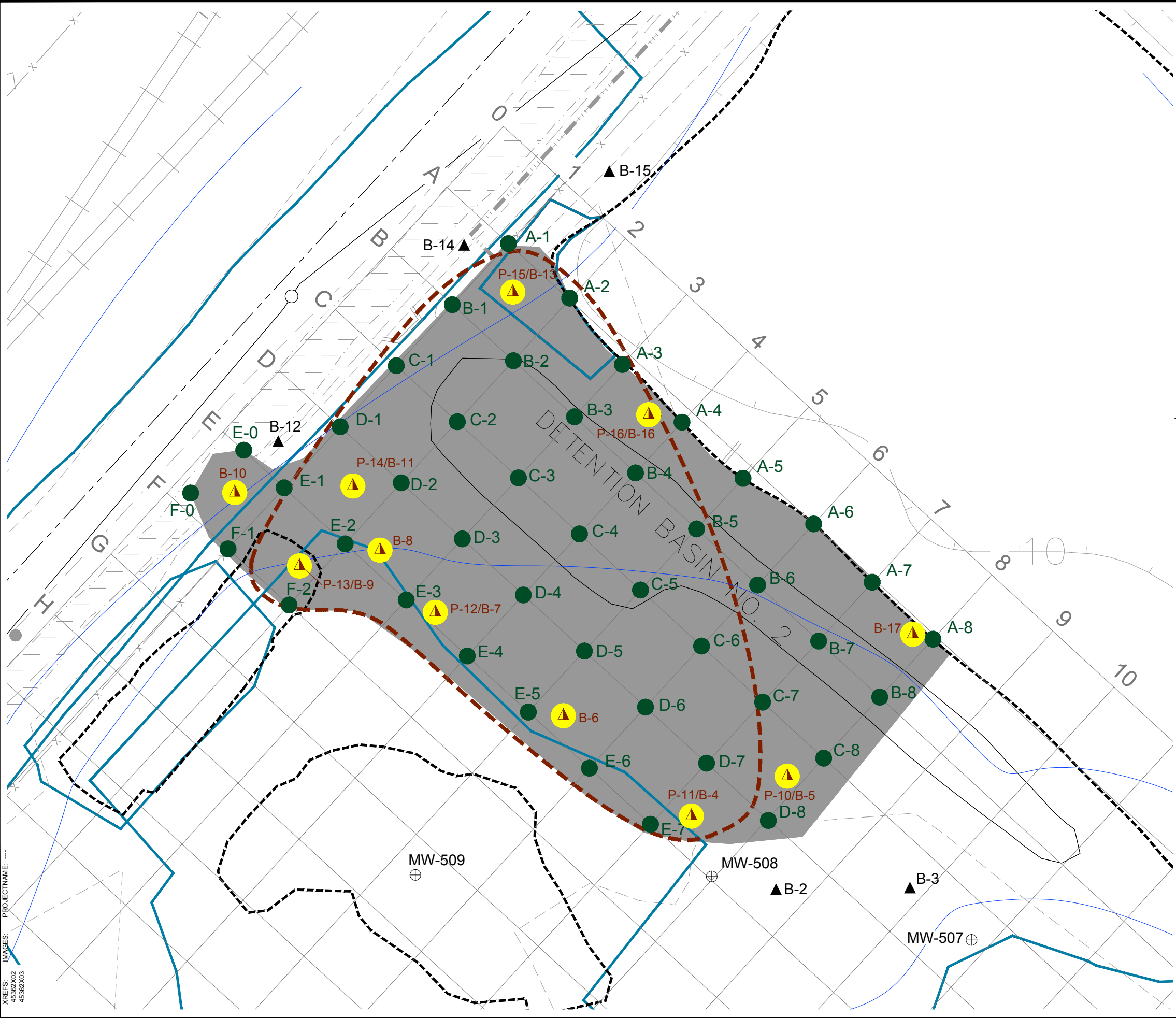

LEGEND:

- ESTIMATED LNAPL BOUNDARY
- MW-203 ⊕ INTERIOR MONITORING WELL LOCATION AND DESIGNATION
- MW-122 ⊕ DEEP MONITORING WELL LOCATION AND DESIGNATION
- MW-109 ⊕ PERIMETER MONITORING WELL LOCATION
- MW-301 ⊙ BNSF WELL LOCATION
- P-11 ⊠ PIEZOMETER
- SOIL SAMPLE COLLECTION LOCATION WITH CONCENTRATIONS OF TPH AND/OR cPAH, EXCEEDING APPLICABLE SITE CULs AND/OR RELs.
- cPAH CARCINOGENIC POLYNUCLEAR AROMATIC HYDROCARBONS, ADJUSTED FOR TOXICITY.
- CUL CLEANUP LEVEL
- REL REMEDIATION LEVEL
- TPH TOTAL PETROLEUM HYDROCARBONS
- AREA OF EXCAVATION
- 2001 AND 2003 SOIL EXCAVATIONS BELOW GROUNDWATER TABLE
- PROPERTY BOUNDARY
- 2007/2008 EXCAVATION BOUNDARIES
- PROPOSED CONFIRMATION SOIL SAMPLE LOCATION

- NOTES:**
1. HORIZONTAL DATUM: WASHINGTON STATE COORDINATE SYSTEM NORTH ZONE (NAD 83/98).
 VERTICAL DATUM: N.A.V.D. 88
 UNITS: U.S. SURVEY FEET
 HORIZONTAL AND VERTICAL CONTROL ESTABLISHED BY GPS VIA VERTICAL REFERENCE STATION NETWORK (VRSN).
 2. SOUTHEAST PORTION OF WSDOT STORM DRAIN LINE HAS NOT BEEN SURVEYED.

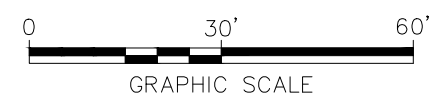

CHEVRON ENVIRONMENTAL MANAGEMENT COMPANY
 FORMER UNOCAL BULK FUEL TERMINAL
 EDMONDS, WASHINGTON
SAMPLING AND ANALYSIS PLAN

**DENTENTION BASIN NO. 2
 PROPOSED SAMPLE LOCATIONS**

ARCADIS

FIGURE
F-3

CITY: PETALUMA, CA DIV/GROUP: ENV. DB: J. HARRIS LD: -- PIC: -- BM: TM: LYR: (OPTIONAL) OFF-REF: 1:\acad\proj\05045362\IN\PIV\DIV\B0045362 F-4.dwg LAYOUT: F-4. DWG LAYOUT: F-4. ACADVER: 18.15 (LIMS TECH) PAGES: 10 PAGESETUP: -- PLOTSTYLETABLE: ARCADIS.CTB PLOTTED: 2/16/2015 11:55 AM BY: HUTCHINS-WASS, TABITHA

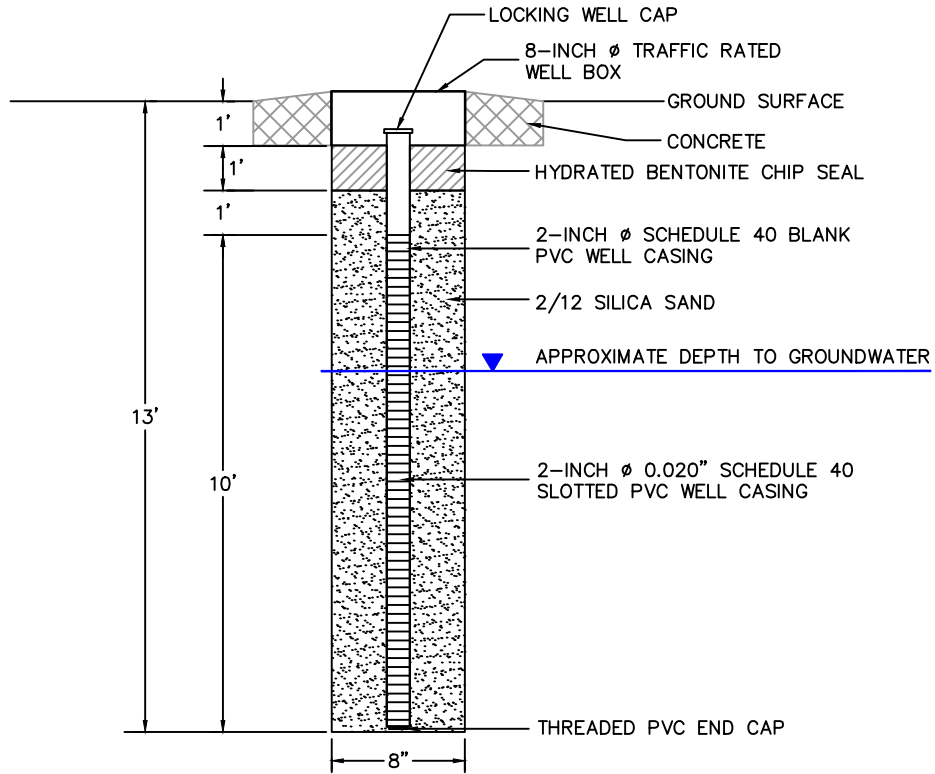

NOTE: DRAWING IS NOT SCALED.

CHEVRON ENVIRONMENTAL MANAGEMENT COMPANY
FORMER UNOCAL EDMONDS BULK FUEL TERMINAL
EDMONDS, WASHINGTON
SAMPLING AND ANALYSIS PLAN

**PROPOSED MONITORING WELL
CONSTRUCTION DETAIL**



FIGURE
F-4



Appendix F Attachments

Surface and Subsurface Soil Sampling Using Manual Methods

Rev. #: 1

Rev Date: March 6, 2009

Approval Signatures

Prepared by: *Michael J. Goff* Date: 3/6/09

Reviewed by: *Todd L. Murray* Date: 3/6/09
(Technical Expert)

I. Scope and Application

This document describes procedures for surface and subsurface soil sampling using hand tools.

II. Personnel Qualifications

ARCADIS personnel directing, supervising, or leading soil sampling activities should have a minimum of 2 years of previous environmental soil sampling experience. ARCADIS personnel providing assistance to soil sample collection and associated activities should have a minimum of 6 months of related experience or an advanced degree in environmental sciences.

III. Equipment List

The following materials will be available, as required, during soil sampling activities:

- personal protective equipment (PPE), as specified by the site Health and Safety Plan (HASP);
- stainless steel bowls;
- stainless steel spoons;
- stainless steel spades;
- stainless steel hand augers;
- indelible ink pens;
- engineer's ruler or survey rod;
- sealable plastic bags (e.g., Ziploc®);
- equipment decontamination materials
- sample bottles and preservatives appropriate for the parameters to be sampled for laboratory analysis, if any;
- transport container with ice (if sampling for laboratory analysis);
- appropriate sample containers and forms; and

- field notebook and/or personal digital assistant (PDA).

Documentation forms and notebooks to have on hand include: soil sample log forms, chain-of-custody forms, sample labels and seals, field logbook/PDA.

IV. Cautions / Hazards

Task specific Job Safety Analysis (JSAs) must be developed to identify site hazards associated with the investigation and reviewed by all field crew members prior to the start of work. Safe Performance Self-Assessment (SPSA) to be performed by employees before performing a new task. Underground utilities will be cleared per the ARCADIS Utility Location Policy and Procedure.

V. Health and Safety Considerations

Soil sample collection will be performed in accordance with a site-specific Health and Safety Plan (HASP) and task specific JSA forms, copies of which will be present on site during such activities.

VI. Procedure

Soil samples may be collected at intervals from the ground surface to various depths. Sample locations will be identified using stakes, flagging, or other appropriate means, and will be noted in a field logbook, PDA, and/or soil sampling logs. Sample points will be located by surveying, use of a global positioning system (GPS), and/or measurements from other surveyed site features.

1. Equipment that will come in contact with the soil sample should be cleaned in accordance with the appropriate equipment decontamination SOP(s), or else new, disposable equipment should be used. Collect equipment blanks in accordance with the project Quality Assurance Project Plan (QAPP).
2. Clear the ground surface of brush, root mat, grass, leaves, or other debris.
3. Use a spade, spoon, scoop, or hand auger to collect a sample of the required depth interval.
4. Use an engineer's ruler to verify that the sample is collected to the correct depth and record the top and bottom depths from the ground surface.
5. To collect samples below the surface interval, remove the surface interval first; then collect the deeper interval. To prevent the hole from collapsing, it may be

necessary to remove a wider section from the surface or use cut polyvinyl chloride (PVC) tubing or pipe to maintain the opening.

6. Collect samples for volatile organic compounds (VOCs) as discrete samples using Encore® samplers or cut syringes (see Extraction/Preservation of Soil/Sediment Samples for VOCs SOP).
7. Homogenize samples for other analyses across the required interval or mix them with other discrete grab samples to form a composite sample (see Compositing or Homogenizing Samples SOP).
8. Place sample in clean sample container; label with sample identification number, date, and time of collection; and place on ice (if obtained for laboratory analysis). Prepare samples for packaging and shipping to the laboratory in accordance with the Chain-of-Custody Handling, Packing, and Shipping SOP.
9. Backfill sample holes to grade with native material or with clean builder's sand or other suitable material.

VII. Waste Management

Waste soils will be managed as specified in the FSP or Work Plan, and according to state and /or federal requirements. Personal Protective Equipment (PPE) and decontamination fluids will be contained separately and staged at the project site for appropriate disposal. Waste containers must be a sealed and labeled at the time of generation. Labels will indicate date, sample locations, site name, city, state, and description of the matrix (e.g., soil, PPE).

VIII. Data Recording and Management

Field documentation such as log book entries and chain-of –custody records will be transmitted to the ARCADIS PM or Task Manager each day unless otherwise directed. The field team leader will retain all site documentation while in the field and add to project files when the field mobilization is complete.

IX. Quality Assurance

Quality assurance samples (rinse blanks, duplicates, and MS/MSDs) will be collected at the frequency specified in the FSP and/or QAPP and depending on the project quality objectives. Reusable soil sampling equipment will be cleaned prior to use following equipment cleaning SOP. Field rinse blanks will be used to confirm that decontamination procedures are sufficient and samples are representative of site

conditions. Any deviations from the SOP will be discussed with the project manager prior to changing any field procedures.

Field Equipment Decontamination

Rev. #: 3

Rev Date: April 26, 2010

Approval Signatures

Prepared by: 
Keith Shepherd

Date: 4/26/2010

Reviewed by: 
Richard Murphy (Technical Expert)

Date: 4/26/2010

I. Scope and Application

Equipment decontamination is performed to ensure that sampling equipment that contacts a sample, or monitoring equipment that is brought into contact with environmental media to be sampled, is free from analytes of interest and/or constituents that would interfere with laboratory analysis for analytes of interest. Equipment must be cleaned prior to use for sampling or contact with environmental media to be sampled, and prior to shipment or storage. The effectiveness of the decontamination procedure should be verified by collecting and analyzing equipment blank samples.

The equipment cleaning procedures described herein includes pre-field, in the field, and post-field cleaning of sampling tools which will be conducted at an established equipment decontamination area (EDA) on site (as appropriate). Equipment that may require decontamination at a given site includes: soil sampling tools; groundwater, sediment, and surface-water sampling devices; water testing instruments; down-hole instruments; and other activity-specific sampling equipment. Non-disposable equipment will be cleaned before collecting each sample, between sampling events, and prior to leaving the site. Cleaning procedures for sampling equipment will be monitored by collecting equipment blank samples as specified in the applicable work plan or field sampling plan. Dedicated and/or disposable (not to be re-used) sampling equipment will not require decontamination.

II. Personnel Qualifications

ARCADIS field sampling personnel will have current health and safety training, including 40-hour HAZWOPER training, site supervisor training, and site-specific training, as needed. In addition, ARCADIS field sampling personnel will be versed in the relevant SOPs and possess the skills and experience necessary to successfully complete the desired fieldwork. The project HASP and other documents will identify any other training requirements such as site specific safety training or access control requirements.

III. Equipment List

- health and safety equipment, as required in the site Health and Safety Plan (HASP)
- distilled water

- Non-phosphate detergent such as Alconox or, if sampling for phosphorus phosphorus-containing compounds, Luminox (or equivalent).
- tap water
- rinsate collection plastic containers
- DOT-approved waste shipping container(s), as specified in the work plan or field sampling plan (if decontamination waste is to be shipped for disposal)
- brushes
- large heavy-duty garbage bags
- spray bottles
- (Optional) – Isopropyl alcohol (free of ketones) or methanol
- Ziploc-type bags
- plastic sheeting

IV. Cautions

Rinse equipment thoroughly and allow the equipment to dry before re-use or storage to prevent introducing solvent into sample medium. If manual drying of equipment is required, use clean lint-free material to wipe the equipment dry.

Store decontaminated equipment in a clean, dry environment. Do not store near combustion engine exhausts.

If equipment is damaged to the extent that decontamination is uncertain due to cracks or dents, the equipment should not be used and should be discarded or submitted for repair prior to use for sample collection.

A proper shipping determination will be performed by a DOT-trained individual for cleaning materials shipped by ARCADIS.

V. Health and Safety Considerations

Review the material safety data sheets (MSDS) for the cleaning materials used in decontamination. If solvent is used during decontamination, work in a well-ventilated area and stand upwind while applying solvent to equipment. Apply solvent in a manner that minimizes potential for exposure to workers. Follow health and safety procedures outlined in the HASP.

VI. Procedure

A designated area will be established to clean sampling equipment in the field prior to sample collection. Equipment cleaning areas will be set up within or adjacent to the specific work area, but not at a location exposed to combustion engine exhaust. Detergent solutions will be prepared in clean containers for use in equipment decontamination.

Cleaning Sampling Equipment

1. Wash the equipment/pump with potable water.
2. Wash with detergent solution (Alconox, Liquinox or equivalent) to remove all visible particulate matter and any residual oils or grease.
3. If equipment is very dirty, precleaning with a brush and tap water may be necessary.
4. (Optional) – Flush with isopropyl alcohol (free of ketones) or with methanol. This step is optional but should be considered when sampling in highly impacted media such as non-aqueous phase liquids or if equipment blanks from previous sampling events showed the potential for cross contamination of organics.
5. Rinse with distilled/deionized water.

Decontaminating Submersible Pumps

Submersible pumps may be used during well development, groundwater sampling, or other investigative activities. The pumps will be cleaned and flushed before and between uses. This cleaning process will consist of an external detergent solution wash and tap water rinse, a flush of detergent solution through the pump, followed

by a flush of potable water through the pump. Flushing will be accomplished by using an appropriate container filled with detergent solution and another contained filled with potable water. The pump will run long enough to effectively flush the pump housing and hose (unless new, disposable hose is used). Caution should be exercised to avoid contact with the pump casing and water in the container while the pump is running (do not use metal drums or garbage cans) to avoid electric shock. Disconnect the pump from the power source before handling. The pump and hose should be placed on or in clean polyethylene sheeting to avoid contact with the ground surface.

VII. Waste Management

Equipment decontamination rinsate will be managed in conjunction with all other waste produced during the field sampling effort. Waste management procedures are outlined in the work plan or Waste Management Plan (WMP).

VIII. Data Recording and Management

Equipment cleaning and decontamination will be noted in the field notebook. Information will include the type of equipment cleaned, the decontamination location and any deviations from this SOP. Specific factors that should be noted include solvent used (if any), and source of water.

Any unusual field conditions should be noted if there is potential to impact the efficiency of the decontamination or subsequent sample collection.

An inventory of the solvents brought on site and used and removed from the site will be maintained in the files. Records will be maintained for any solvents used in decontamination, including lot number and expiration date.

Containers with decontamination fluids will be labeled.

IX. Quality Assurance

Equipment blanks should be collected to verify that the decontamination procedures are effective in minimizing potential for cross contamination. The equipment blank is prepared by pouring deionized water over the clean and dry tools and collecting the deionized water into appropriate sample containers. Equipment blanks should be analyzed for the same set of parameters that are performed on the field samples collected with the equipment that was cleaned. Equipment blanks are collected per equipment set, which represents all of the tools needed to collect a specific sample.

X. References

USEPA Region 9, Field Sampling Guidance #1230, Sampling Equipment Decontamination.

USEPA Region 1, Low Stress (low flow) Purging and Sampling Procedure for the Collection of Groundwater Samples from Monitoring Wells.

Chain-of-Custody, Handling, Packing and Shipping

Rev. #: 2

Rev Date: March 6, 2009

I. Scope and Application

This Standard Operating Procedure (SOP) describes the chain-of-custody, handling, packing, and shipping procedures for the management of samples to decrease the potential for cross-contamination, tampering, mis-identification, and breakage, and to insure that samples are maintained in a controlled environment from the time of collection until receipt by the analytical laboratory.

II. Personnel Qualifications

ARCADIS field sampling personnel will have current health and safety training, including 40-hour HAZWOPER training, Department of Transportation (DOT) training, site supervisor training, and site-specific training, as needed. In addition, ARCADIS field sampling personnel will be versed in the relevant SOPs and possess the skills and experience necessary to successfully complete the desired field work.

III. Equipment List

The following list provides materials that may be required for each project. Project documents and sample collection requirements should be reviewed prior to initiating field operations:

- indelible ink pens (black or blue);
- polyethylene bags (resealable-type);
- clear packing tape, strapping tape, duct tape;
- chain of custody
- DOT shipping forms, as applicable
- custody seals or tape;
- appropriate sample containers and labels,;
- insulated coolers of adequate size for samples and sufficient ice to maintain 4°C during collection and transfer of samples;
- wet ice;
- cushioning and absorbent material (i.e., bubble wrap or bags);

- temperature blank
- sample return shipping papers and addresses; and
- field notebook.

IV. Cautions

Review project requirements and select appropriate supplies prior to field mobilization.

Insure that appropriate sample containers with applicable preservatives, coolers, and packing material have been supplied by the laboratory.

Understand the offsite transfer requirements for the facility at which samples are collected.

If overnight courier service is required schedule pick-up or know where the drop-off service center is located and the hours of operation. Prior to using air transportation, confirm air shipment is acceptable under DOT and International Air Transport Association (IATA) regulation

Schedule pick-up time for laboratory courier or know location of laboratory/service center and hours of operation.

Understand DOT and IATA shipping requirements and evaluate dangerous goods shipping regulations relative to the samples being collected (i.e. complete an ARCADIS shipping determination). Review the ARCADIS SOPs for shipping, packaging and labeling of dangerous goods. Potential samples requiring compliance with this DOT regulation include:

- Methanol preservation for Volatile Organic Compounds in soil samples
- Non-aqueous phase liquids (NAPL)

V. Health and Safety Considerations

Follow health and safety procedures outlined in the project/site Health and Safety Plan (HASP).

Use caution and appropriate cut resistant gloves when tightening lids to 40 mL vials. These vials can break while tightening and can lacerate hand. Amber vials (thinner glass) are more prone to breakage.

Some sample containers contain preservatives.

- The preservatives must be retained in the sample container and should in no instance be rinsed out.
- Preservatives may be corrosive and standard care should be exercised to reduce potential contact to personnel skin or clothing. Follow project safety procedures if spillage is observed.
- If sample container caps are broken discard the bottle. Do not use for sample collection.

VI. Procedure

Chain-of-Custody Procedures

1. Prior to collecting samples, complete the chain-of-custody record header information by filling in the project number, project name, and the name(s) of the sampling technician(s) and other relevant project information. Attachment 1 provides an example chain-o- custody record
2. Chain-of-custody information **MUST** be printed legibly using indelible ink (black or blue).
3. After sample collection, enter the individual sample information on the chain-of-custody:
 - a. Sample Identification indicates the well number or soil location that the sample was collected from. Appropriate values for this field include well locations, grid points, or soil boring identification numbers (e.g., MW-3, X-20, SB-30). When the depth interval is included, the complete sample ID would be "SB-30 (0.5-1.0) where the depth interval is in feet. Please note it is very important that the use of hyphens in sample names and depth units (i.e., feet or inches) remain consistent for all samples entered on the chain-of-custody form. **DO NOT** use the apostrophe or quotes in the sample ID. Sample names may also use the abbreviations "FB," "TB," and "DUP" as prefixes or suffixes to indicate that the sample is a field blank, trip blank, or field duplicate, respectively. **NOTE:** The sample

nomenclature may be dictated by the project database and require unique identification for each sample collected for the project. Consult the project data management plan for additional information regarding sample identification.

- b. List the date of sample collection. The date format to be followed should be mm/dd/yy (e.g., 03/07/09) or mm/dd/yyyy (e.g. 03/07/2009).
- c. List the time that the sample was collected. The time value should be presented using military format. For example, 3:15 P.M. should be entered as 15:15.
- d. The composite field should be checked if the sample is a composite over a period of time or from several different locations and mixed prior to placing in sample containers.
- e. The "Grab". field should be marked with an "X" if the sample was collected as an individual grab sample. (e.g. monitoring well sample or soil interval).
- f. Any sample preservation should be noted.
- g. The analytical parameters that the samples are being analyzed for should be written legibly on the diagonal lines. As much detail as possible should be presented to allow the analytical laboratory to properly analyze the samples. For example, polychlorinated biphenyl (PCB) analyses may be represented by entering "PCBs" or "Method 8082." Multiple methods and/or analytical parameters may be combined for each column (e.g., PCBs/VOCs/SVOCs or 8082/8260/8270). These columns should also be used to present project-specific parameter lists (e.g., Appendix IX+3 target analyte list. Each sample that requires a particular parameter analysis will be identified by placing the number of containers in the appropriate analytical parameter column. For metals in particular, indicate which metals are required.
- h. Number of containers for each method requested. This information may be included under the parameter or as a total for the sample based on the chain of custody form used.
- i. Note which samples should be used for site specific matrix spikes.
- j. Indicate any special project requirements.

- k. Indicate turnaround time required.
 - l. Provide contact name and phone number in the event that problems are encountered when samples are received at the laboratory.
 - m. If available attach the Laboratory Task Order or Work Authorization forms
 - n. The remarks field should be used to communicate special analytical requirements to the laboratory. These requirements may be on a per sample basis such as “extract and hold sample until notified,” or may be used to inform the laboratory of special reporting requirements for the entire sample delivery group (SDG). Reporting requirements that should be specified in the remarks column include: 1) turnaround time; 2) contact and address where data reports should be sent; 3) name of laboratory project manager; and 4) type of sample preservation used.
 - o. The “Relinquished By” field should contain the signature of the sampling technician who relinquished custody of the samples to the shipping courier or the analytical laboratory.
 - p. The “Date” field following the signature block indicates the date the samples were relinquished. The date format should be mm/dd/yyyy (e.g., 03/07/2005).
 - q. The “Time” field following the signature block indicates the time that the samples were relinquished. The time value should be presented using military format. For example, 3:15 P.M. should be entered as 15:15.
 - r. The “Received By” section is signed by sample courier or laboratory representative who received the samples from the sampling technician or it is signed upon laboratory receipt from the overnight courier service.
3. Complete as many chain-of-custody forms as necessary to properly document the collection and transfer of the samples to the analytical laboratory.
 4. Upon completing the chain-of-custody forms, forward two copies to the analytical laboratory and retain one copy for the field records.
 5. If electronic chain-of-custody forms are utilized, sign the form and make 1 copy for ARCADIS internal records and forward the original with the samples to the laboratory.

Handling Procedures

1. After completing the sample collection procedures, record the following information in the field notebook with indelible ink:
 - project number and site name;
 - sample identification code and other sample identification information, if appropriate;
 - sampling method;
 - date;
 - name of sampler(s);
 - time;
 - location (project reference);
 - location of field duplicates and both sample identifications;
 - locations that field QC samples were collected including equipment blanks, field blanks and additional sample volume for matrix spikes; and
 - any comments.
2. Complete the sample label with the following information in indelible ink:
 - sample type (e.g., surface water);
 - sample identification code and other sample identification information, if applicable;
 - analysis required;
 - date;
 - time sampled; and
 - initials of sampling personnel;

- sample matrix; and
 - preservative added, if applicable.
3. Cover the label with clear packing tape to secure the label onto the container and to protect the label from liquid.
 4. Confirm that all caps on the sample containers are secure and tightly closed.
 5. In some instances it may be necessary to wrap the sample container cap with clear packing tape to prevent it from becoming loose.
 6. For some projects individual custody seals may be required. Custody seal evidence tape may be placed on the shipping container or they may be placed on each sample container such that the cooler or cap cannot be opened without breaking the custody seal. The custody seal should be initialed and dated prior to relinquishing the samples.

Packing Procedures

Following collection, samples must be placed on wet ice to initiate cooling to 4°C immediately. Retain samples on ice until ready to pack for shipment to the laboratory.

1. Secure the outside and inside of the drain plug at the bottom of the cooler being used for sample transport with “Duct” tape.
2. Place a new large heavy duty plastic garbage bag inside each cooler
3. Place each sample bottle wrapped in bubble wrap inside the garbage bag. VOC vials may be grouped by sample in individual resealable plastic bags). If a cooler temperature blank is supplied by the laboratory, it should be packaged following the same procedures as the samples. If the laboratory did not include a temperature blank, do not add one. Place 1 to 2 inches of cushioning material (i.e., vermiculite) at the bottom of the cooler.
4. Place the sealed sample containers upright in the cooler.
5. Package ice in large resealable plastic bags and place inside the large garbage bag in the cooler. Samples placed on ice will be cooled to and maintained at a temperature of approximately 4°C.

6. Fill the remaining space in the cooler with cushioning material such as bubble wrap. The cooler must be securely packed and cushioned in an upright position and be surrounded (Note: to comply with 49 CFR 173.4, filled cooler must not exceed 64 pounds).
7. Place the completed chain-of-custody record(s) in a large resealable bag and tape the bag to the inside of the cooler lid.
8. Close the lid of the cooler and fasten with packing tape.
9. Wrap strapping tape around both ends of the cooler.
10. Mark the cooler on the outside with the following information: shipping address, return address, "Fragile, Handle with Care" labels on the top and on one side, and arrows indicating "This Side Up" on two adjacent sides.
11. Place custody seal evidence tape over front right and back left of the cooler lid, initial and date, then cover with clear plastic tape.

Note: Procedure numbers 2, 3, 5, and 6 may be modified in cases where laboratories provide customized shipping coolers. These cooler types are designed so the sample bottles and ice packs fit snugly within preformed styrofoam cushioning and insulating packing material.

Shipping Procedures

1. All samples will be delivered by an express carrier within 48 hours of sample collection. Alternatively, samples may be delivered directly to the laboratory or laboratory service center or a laboratory courier may be used for sample pickup.
2. If parameters with short holding times are required (e.g., VOCs [EnCore™ Sampler], nitrate, nitrite, ortho-phosphate and BOD), sampling personnel will take precautions to ship or deliver samples to the laboratory so that the holding times will not be exceeded.
3. Samples must be maintained at 4°C±2°C until shipment and through receipt at the laboratory
4. All shipments must be in accordance with DOT regulations and ARCADIS dangerous goods shipping SOPs.

5. When the samples are received by the laboratory, laboratory personnel will complete the chain-of-custody by recording the date and time of receipt of samples, measuring and recording the internal temperature of the shipping container, and checking the sample identification numbers on the containers to ensure they correspond with the chain-of-custody forms.

Any deviations between the chain-of-custody and the sample containers, broken containers, or temperature excursions will be communicated to ARCADIS immediately by the laboratory.

VII. Waste Management

Not applicable

VIII. Data Recording and Management

Chain-of-custody records will be transmitted to the ARCADIS PM or designee at the end of each day unless otherwise directed by the ARCADIS PM. The sampling team leader retains copies of the chain-of-custody forms for filing in the project file. Record retention shall be in accordance with project requirements.

IX. Quality Assurance

Chain-of-custody forms will be legibly completed in accordance with the applicable project documents such as Sampling and Analysis Plan (SAP), Quality Assurance Project Plan (QAPP), Work Plan, or other project guidance documents. A copy of the completed chain-of-custody form will be sent to the ARCADIS Project Manager or designee for review.

X. References

Not Applicable

Photoionization Detector Air Monitoring and Field Screening

Rev. #: 1

Rev Date: November 8, 2009

Approval Signatures

Prepared by: (the late) Maureen Geisser

Date: July 28, 2003



Reviewed/revised by: Christopher C. Lutes
(Technical Expert)

Date: November 8, 2009

I. Scope and Application

Field screening with a photoionization detector (PID), such as an HNu™, Photovac™, MicroTIP™, or MiniRAE™, is a procedure to measure relative concentrations of volatile organic compounds (VOCs) and other compounds. Characteristics of the PID are presented in Attachment 1 and the compounds a PID can detect are presented in Attachment 2. Field screening will frequently be conducted on the following:

- Work area air to assess exposure to on-site workers of air contaminants via the air pathway;
- Well headspaces as a precautionary measure each time the well cover is opened; and
- Headspace of soil samples to assess the relative concentration of volatile organics in the sample or to select particular intervals for off-site analysis for VOCs.

II. Personnel Qualifications

Personnel performing this method should be familiar with the basic principles of quantitative analytical chemistry (such as calibration) and familiar with the particular operation of the instrument to be used.

III. Equipment List

The following materials, as required, shall be available while performing PID field screening:

- personal protective equipment (PPE), as required by the site Health and Safety Plan (HASP);
- PID and operating manual;
- PID extra battery pack and battery charger;
- calibration canisters for the PID;
- sample jars;
- Q-tips;

- aluminum foil;
- field calibration log (attached); and
- field notebook.

IV. Cautions

PIDs are sensitive to moisture and may not function under high humidity. PIDs cannot be used to indicate oxygen deficiency or combustible gases.

V. Health and Safety Considerations

Since the PIDs cannot detect all of the chemicals that may be present at a sample location, a zero reading on either instrument does not necessarily signify the absence of air contaminants. PIDs cannot be used as an indicator for oxygen deficiency.

VI. Procedure (*Note these procedures were written particular to one specific instrument model, therefore please also refer to your owners manual. However the general principles – such as always measuring both a zero and span gas after an instrument adjustment/at the beginning of the analytical day, after four hours of testing and again at the end of an analytical day can be applied to all instruments.*)

PID Calibration

PID field instruments will be calibrated and operated to yield “total organic vapor” in parts per million (ppm) (v/v) relative to benzene or isobutylene (or equivalent). Operation, maintenance, and calibration shall be performed in accordance with the manufacturer’s instructions and entered on the PID calibration and maintenance log (Attachment 3).

1. Don PPE, as required by the HASP.
2. Perform a BATTERY CHECK. Turn the FUNCTION switch to the BATTERY CHECK position. Check that the indicator is within or beyond the green battery arc. If battery is low, the battery must be charged before calibration.
3. Allow the instrument to warm up, then calibrate the PID. If equipped, turn the FUNCTION switch to the STANDBY position and rotate the ZERO

POTENTIOMETER until the meter reads zero with the instrument sampling clean air. Wait 15 to 20 seconds to confirm the adjustment. If unstable, readjust. If equipped, check to see that the SPAN POTENTIOMETER is adjusted for the probe being used (e.g., 9.8 for 10.2 electron volts [eV]). Set the FUNCTION switch to the desired ppm range (0-20, 0-200, or 0-2,000). A violet glow from the ultraviolet (UV) source should be visible at the sample inlet of the probe/sensor unit.

4. Listen for the fan operation to verify fan function.
5. Connect one end of the sampling hose to the calibration canister regulator outlet and the other end to the sampling probe of the PID. Crack the regulator valve and take a reading after 5 to 10 seconds. Adjust the span potentiometer to produce the concentration listed on the span gas cylinder. Record appropriate information on a PID Calibration and Maintenance Log (Attachment 3, or equivalent).
6. If so equipped, set the alarm at desired level.
7. Recheck the zero with fresh/clean air
8. Always recheck both zero and span after making any instrment adjustment, after four hours of screenign work and again after sample analysis.

Work Area Air Monitoring

1. Measure and record the background PID reading.
2. Measure and record the breathing space reading.

Well Headspace Screening

1. Measure and record the background PID reading.
2. Unlock and open the well cover while standing upwind of the well.
3. Remove the well cap.
4. Place the PID probe approximately 6 inches above the top of the casing.
5. Record all PID readings and proceed in accordance with the HASP.

Field Screening Procedures

Soil samples will be field screened upon collection with the PID for a relative measure of the total volatile organic concentration. The following steps define the PID field screening procedures.

1. Half-fill two clean glass jars with the sample (if sufficient quantities of soil are available) to be analyzed. Quickly cover each open top with one or two sheets of clean aluminum foil and subsequently apply screw caps to tightly seal the jars. Sixteen-ounce (approximately 500 mL) soil or "mason" type jars are preferred; jars less than 8 ounces (approximately 250 mL) total capacity may not be used.
2. Allow headspace development for at least 10 minutes. Vigorously shake jars for 15 seconds at both the beginning and end of the headspace development period. Where ambient temperatures are below 32°F (0°C), headspace development should be within a heated building.
3. Subsequent to headspace development, remove screw lid to expose the foil seal. Quickly puncture foil seal with instrument sampling probe, to a point about one-half of the headspace depth. Exercise care to avoid contact with water droplets or soil particulates.
4. Following probe insertion through foil seal, record the highest meter response for each sample as the jar headspace concentration. Using the foil seal/probe insertion method, maximum response should occur between 2 and 5 seconds. Erratic meter response may occur at high organic vapor concentrations or conditions of elevated headspace moisture, in which case headspace data should be recorded and erratic meter response noted.
5. The headspace screening data from both jar samples should be recorded and compared; generally, replicate values should be consistent to plus or minus 20%. It should be noted that in some cases (e.g., 6-inch increment soil borings), sufficient sample quantities may not be available to perform duplicate screenings. One screening will be considered sufficient for this case.
6. PID field instruments will be operated and calibrated to yield "total organic vapors" in ppm (v/v) as benzene. PID instruments must be operated with at least a 10.0 eV (+) lamp source. Operation, maintenance, and calibration will be performed in accordance with the manufacturer's specifications presented in Attachment 12-1. For jar headspace analysis, instrument calibration will be checked/adjusted at least twice per day, at the beginning and end of each day

of use. Calibration will exceed twice per day if conditions and/or manufacturer's specifications dictate.

7. Instrumentation with digital (LED/LCD) displays may not be able to discern maximum headspace response unless equipped with a "maximum hold" feature or strip-chart recorder.

VII. Waste Management

Do not dispose canisters of compressed gas, if there is still compressed gas in the canister. Return the canister to the manufacturer for proper disposal.

VIII. Data Recording and Management

Measurements will be recorded in the field notebook or boring logs at the time of measurement with notation of date, time, location, depth (if applicable), and item monitored. If a data memory is available, readings will be downloaded from the unit upon access to a computer with software to retrieve the data.

IX. Quality Assurance

After each use, the readout unit should be wiped down with a clean cloth or paper towel.

For a HNu, the UV light source window and ionization chamber should be cleaned once a month in the following manner:

1. With the PID off, disconnect the sensor/probe from the unit.
2. Remove the exhaust screw, grasp the end cap in one hand and the probe shell in the other, and pull apart.
3. Loosen the screws on top of the end cap and separate the end cap and ion chamber from the lamp and lamp housing.
4. Tilt the lamp housing with one hand over the opening so that the lamp slides out into your hand.
5. Clean the lamp with lens paper and HNu cleaning compound (except 11.7 eV). For the 11.7 eV lamp, use a chlorinated organic solvent.

6. Clean the ion chamber using methanol on a Q-tip and then dry gently at 50°C to 60°C for 30 minutes.
7. Following cleaning, reassemble by first sliding the lamp back into the lamp housing. Place ion chamber on top of the housing, making sure the contacts are properly aligned.
8. Place the end cap on top of the ion chamber and replace the two screws (tighten the screws only enough to seal the o-ring).
9. Line up the pins on the base of the lamp housing with pins inside the probe shell and slide the housing assembly into the shell.

X. References

Denahan, S.A. et. al "Relationships Between Chemical Screening Methodologies for Petroleum Contaminated Soils: Theory and Practice" *Chapter 5 In Principles and Practices for Petroleum Contaminated Soils*, E.J. Calabrese and P.T. Kostecki Eds., Lewis Publishers 1993.

Fitzgerald, J. "Onsite Analytical Screening of Gasoline Contaminated Media Using a Jar Headspace Procedure" *Chapter 4 in Principles and Practices for Petroleum Contaminated Soils*, E.J. Calabrese and P.T. Kostecki Eds., Lewis Publishers 1993.

ATTACHMENT 1

Characteristics of the Photoionization Detector (PID)

I. Introduction

PIDs are used in the field to detect a variety of compounds in air. PIDs can be used to detect leaks of volatile substances in drums and tanks, to determine the presence of volatile compounds in soil and water, and to make ambient air surveys. If personnel are thoroughly trained to operate the instrument and interpret the data, these PID instruments can be a valuable tool. Its use can help in deciding the level of protection to be worn, assist in determining the implementation of other safety procedures, and in determining subsequent monitoring or sampling locations.

Portable PIDs detect the concentration of organic gases, as well as a few inorganic gases. The basis for detection is the ionization of gaseous species. The incoming gas molecules are subjected to UV radiation, which ionizes molecules that have an ionization potential (IP) less than or equal to that rated for the UV source. Every molecule has a characteristic IP, which is the energy required to remove an electron from the molecule, thus yielding a positively charged ion and the free electron. These ions are attracted to an oppositely charged electrode, causing a current and an electric signal to the LED display. Compounds are measured on a ppm volume basis.

II. HNu PI-101 / MiniRAE or Equivalent PID

The PIDs detect the concentration of organic gases, as well as a few inorganic gases. The basis for detection is the ionization of gaseous species. The incoming gas molecules are subjected to UV radiation, which is energetic enough to ionize many gaseous compounds. Each molecule is transformed into charged ion pairs, creating a current between two electrodes. Every molecule has a characteristic IP, which is the energy required to remove an electron from the molecule, yielding a positively charged ion and the free electron.

Three probes, each containing a different UV light source, are available for use with the PID. Probe energies are typically 9.5, 10.2, and 11.7 eV, respectively. All three probes detect many aromatic and large-molecule hydrocarbons. In addition, the 10.2 eV and 11.7 eV probes detect some smaller organic molecules and some halogenated hydrocarbons. The 10.2 eV probe is the most useful for environmental response work, as it is more durable than the 11.7 eV probe and detects more compounds than the 9.5 eV probe. A listing of molecules and compounds that the HNu can detect is presented in Attachment 2.

The primary PID calibration gas is either benzene or isobutylene. The span potentiometer knob is turned to 9.8 for benzene calibration. A knob setting of zero increases the sensitivity to benzene approximately 10-fold. Its lower detection limit is in the low ppm range. Additionally, response time is rapid; the dot matrix liquid crystal displays 90% of the indicated concentration within 3 seconds.

III. Limitations

The PID instrument can monitor several vapors and gases in air. Many non-volatile liquids, toxic solids, particulates, and other toxic gases and vapors, however, cannot be detected with PIDs (such as methane). Since the PIDs cannot detect all of the chemicals that may be present at a sample location, a zero reading on either instrument does not necessarily signify the absence of air contaminants.

The PID instrument is generally not specific and their response to different compounds is relative to the calibration gases. Instrument readings may be higher or lower than the true concentration. This effect can be observed when monitoring total contaminant concentrations if several different compounds are being detected at once. In addition, the response of these instruments is not linear over the entire detection range. Therefore, care must be taken when interpreting the data. Concentrations should be reported in terms of the calibration gas and probe type.

PIDs are small, portable instruments and may not yield results as accurate as laboratory instruments. PIDs were originally designed for specific industrial applications. They are relatively easy to use and interpret when detecting total concentrations of known contaminants in air, but interpretation becomes more difficult when trying to identify the individual components of a mixture. PIDs cannot be used as an indicator for combustible gases or oxygen deficiency.

ATTACHMENT 2

Molecules and Compounds Detected by a PID

<u>Some Atoms and Simple Molecules</u>			<u>Paraffins and Cycloparaffins</u>	
	<u>IP(eV)</u>	<u>IP(eV)</u>	<u>Molecule</u>	<u>IP(eV)</u>
H	13.595 I ₂	9.28	methane	12.98
C	11.264 HF	15.77	ethane	11.65
N	14.54 HCl	12.74	propane	11.07
O	13.614 HBr	11.62	n-butane	10.63
Si	8.149 HI	10.38	i-butane	10.57
S	10.357 SO ₂	12.34	n-pentane	10.35
F	17.42 CO ₂	13.79	i-pentane	10.32
Cl	13.01 COS	11.18	2,2-dimethylpropane	10.35
Br	11.84 CS ₂	10.08	n-hexane	10.18
I	10.48 N ₂ O	12.90	2-methylpentane	10.12
H ₂	15.426 NO ₂	9.78	3-methylpentane	10.08
N ₂	15.580 O ₃	12.80	2,2-dimethylbutane	10.06
O ₂	12.075 H ₂ O	12.59	2,3-dimethylbutane	10.02
CO	14.01 H ₂ S	10.46	n-heptane	10.08
CN	15.13 H ₂ Se	9.88	2,2,4-trimethylpentane	9.86
NO	9.25 H ₂ Te	9.14	cyclopropane	10.06
CH	11.1 HCN	3.91	cyclopentane	10.53
OH	13.18 C ₂ N ₂	13.8	cyclohexane	9.88
F ₂	15.7 NH ₃	10.15	methlycyclohexane	9.8
Cl ₂	11.48 CH ₃	9.840		
Br ₂	10.55 CH ₄	12.98		

<u>Alkyl Halides</u>		<u>Alkyl Halides</u>	
<u>IP(eV)</u>	<u>IP(eV)</u>	<u>Molecule</u>	<u>IP(eV)</u>
HCl	12.74	methyl iodide	9.54
Cl ₂	11.48	diiodomethane	9.34
CH ₄	12.98	ethyl iodide	9.33
methyl chloride	11.28	1-iodopropane	9.26
dichloroemthane	11.35	2-iodopropane	9.17
trichloromethane	11.42	1-iodobutane	9.21
tetrachloromethane	11.47	2-iodobutane	9.09
ethyl chloride	10.98	1-iodo-2-methylpropane	9.18
1,2-dichloroethane	11.12	2-iodo-2-methylpropane	9.02
1-chloropropane	10.82	1-iodopentane	9.19
2-chloropropane	10.78	F ₂	15.7
1,2-dichloropropane	10.87	HF	15.77
1,3-dichloropropane	10.85	CFCl ₃ (Freon 11)	11.77
1-chlorobutane	10.67	CF ₂ Cl ₂ (Freon 12)	12.31
2-chlorobutane	10.65	CF ₃ Cl (Freon 13)	12.91
1-chloro-2-methylpropane	10.66	CHClF ₂ (Freon 22)	12.45
2-chloro-2-methylpropane	10.61	CFBR ₃	10.67
HBr	11.62	CF ₂ Br ₂	11.07
Br ₂	10.55	CH ₃ CF ₂ Cl (Genetron 101)	11.98
methyl bromide	10.53	CFCl ₂ CF ₂ Cl	11.99
dibromomethane	10.49	CF ₃ CCl ₃ (Freon 113)	11.78
tribromomethane	10.51	CFHBrCH ₂ Cr	10.75
CH ₂ BrCl	10.77	CF ₂ BrCH ₂ Br	10.83
CHBr ₂ Cl	10.59	CF ₃ CH ₂ I	10.00
ethyl bromide	10.29	n-C ₃ F ₇ I	10.36
1,1-dibromoethane	10.19	n-C ₃ F ₇ CH ₂ Cl	11.84
1-bromo-2-chloroethane	10.63	n-C ₃ F ₇ CH ₂ I	9.96
1-bromopropane	10.18		
2-bromopropane	10.075		
1,3-dibromopropane	10.07		
1-bromobutane	10.13		
2-bromobutane	9.98		
1-bromo-2-methylpropane	10.09		
2-bromo-2-methylpropane	9.89		
1-bromopentane	10.10		
HI	10.38		
I ₂	9.28		

Aliphatic Alcohol, Ether, Thiol, and Sulfides

<u>Molecule</u>	<u>IP(eV)</u>
H ₂ O	12.59
methyl alcohol	10.85
ethyl alcohol	10.48
n-propyl alcohol	10.20
i-propyl alcohol	10.16
n-butyl alcohol	10.04
dimethyl ether	10.00
diethyl ether	9.53
n-propyl ether	9.27
i-propyl ether	9.20
H ₂ S	10.46
methanethiol	9.440
ethanethiol	9.285
1-propanethiol	9.195
1-butanethiol	9.14
dimethyl sulfide	8.685
ethyl methyl sulfide	8.55
diethyl sulfide	8.430
di-n-propyl sulfide	8.30

Aliphatic Aldehydes and Ketones

<u>Molecule</u>	<u>IP(eV)</u>
CO ₂	13.79
formaldehyde	10.87
acetaldehyde	10.21
propionaldehyde	9.98
n-butyraldehyde	9.86
isobutyraldehyde	9.74
n-valeraldehyde	9.82
isovaleraldehyde	9.71
acrolein	10.10
crotonaldehyde	9.73
benzaldehyde	9.53
acetone	9.69
methyl ethyl ketone	9.53
methyl n-propyl ketone	9.39
methyl i-propyl ketone	9.32
diethyl ketone	9.32
methyl n-butyl ketone	9.34
methyl i-butyl ketone	9.30
3,3-dimethyl butanone	9.17
2-heptanone	9.33
cyclopentanone	9.26
cyclohexanone	9.14
2,3-butanedione	9.23
2,4-pentanedione	8.87

Aliphatic Acids and Esters

<u>Molecule</u>	<u>IP(eV)</u>
CO ₂	13.79
formic acid	11.05
acetic acid	10.37
propionic acid	10.24
n-butyric acid	10.16
isobutyric acid	10.02
n-valeric acid	10.12
methyl formate	10.815
ethyl formate	10.61
n-propyl formate	10.54
n-butyl formate	10.50
isobutyl formate	10.46
methyl acetate	10.27
ethyl acetate	10.11
n-propyl acetate	10.04
isopropyl acetate	9.99
n-butyl acetate	10.01
isobutyl acetate	9.97
sec-butyl acetate	9.91
methyl propionate	10.15
ethyl propionate	10.00
methyl n-butyrate	10.07
methyl isobutyrate	9.98

Aliphatic Amines and Amides

<u>Molecule</u>	<u>IP(eV)</u>
NH ₃	10.15
methyl amine	8.97
ethyl amine	8.86
n-propyl amine	8.78
i-propyl amine	8.72
n-butyl amine	8.71
i-butyl amine	8.70
s-butyl amine	8.70
t-butyl amine	8.64
dimethyl amine	8.24
diethyl amine	8.01
di-n-propyl amine	7.84
di-i-propyl amine	7.73
di-n-butyl amine	7.69
trimethyl amine	7.82
triethyl amine	7.50
tri-n-propyl amine	7.23
formamide	10.25
acetamide	9.77
N-methyl acetamide	8.90
N,N-dimethyl formamide	9.12
N,N-dimethyl acetamide	8.81
N,N-diethyl formamide	8.89
N,N-diethyl acetamide	8.60

Other Aliphatic Molecules with N Atom

<u>Molecule</u>	<u>IP(eV)</u>
nitromethane	11.08
nitroethane	10.88
1-nitropropane	10.81
2-nitropropane	10.71
HCN	13.91
acetonitrile	12.22
propionitrile	11.84
n-butyronitrile	11.67
acrylonitrile	10.91
3-butene-nitrile	10.39
ethyl nitrate	11.22
n-propyl nitrate	
methyl thiocyanate	10.065
ethyl thiocyanate	9.89
methyl isothiocyanate	9.25
ethyl isothiocyanate	9.14

Olefins, Cyclo-olefins, Acetylenes

<u>Molecule</u>	<u>IP(eV)</u>
ethylene	10.515
propylene	9.73
1-butene	9.58
2-methylpropene	9.23
trans-2-butene	9.13
cis-2-butene	9.13
1-pentene	9.50
2-methyl-1-butene	9.12
3-methyl-1-butene	9.51
3-methyl-2-butene	8.67
1-hexene	9.46
1,3-butadiene	9.07
isoprene	8.845
cyclopentene	9.01
cyclohexene	8.945
4-methylcyclohexene	8.91
4-cinylcyclohexene	8.93
cyclo-octatetraene	7.99
acetylene	11.41
propyne	10.36
1-butyne	10.18

Some Derivatives of Olefins

<u>Molecule</u>	<u>IP(eV)</u>
vinyl chloride	9.995
cis-dichloroethylene	9.65
trans-dichloroethylene	9.66
trichloroethylene	9.45
tetrachloroethylene	9.32
vinyl bromide	9.80
1,2-dibromoethylene	9.45
tribromoethylene	9.27
3-chloropropene	10.04
2,3-dichloropropene	9.82
1-bromopropene	9.30
3-bromopropene	9.7
CF ₃ CCl=CClCF ₃	10.36
n-C ₅ F ₁₁ CF=CF ₂	10.48
acrolein	10.10
crotonaldehyde	9.73
mesityl oxide	9.08
vinyl methyl ether	8.93
allyl alcohol	9.67
vinyl acetate	9.19

Aromatic Compounds

<u>Molecule</u>	<u>IP(eV)</u>
benzene	9.245
toluene	8.82
ethyl benzene	8.76
n-propyl benzene	8.72
i-propyl benzene	8.69
n-butyl benzene	8.69
s-butyl benzene	8.68
t-butyl benzene	8.68
o-xylene	8.56
m-xylene	8.56
p-xylene	8.445
mesitylene	8.40
durene	8.025
styrene	8.47
alpha-methyl styrene	8.35
ethynylbenzene	8.815
naphthalene	8.12
1-methylnaphthalene	7.69
2-methylnaphthalene	7.955
biphenyl	8.27
phenol	8.50
anisole	8.22
phenetole	8.13
benzaldehyde	9.53
acetophenone	9.27
benzenethiol	8.33
phenyl isocyanate	8.77

Aromatic Compounds

<u>Molecule</u>	<u>IP(eV)</u>
phenyl isothiocyanate	8.520
benzonitrile	9.705
nitrobenzene	9.92
aniline	7.70
fluoro-benzene	9.195
chloro-benzene	9.07
bromo-benzene	8.98
iodo-benzene	8.73
o-dichlorobenzene	9.07
m-dichlorobenzene	9.12
p-dichlorobenzene	8.94
1-chloro-2-fluorobenzene	9.155
1-chloro-3-fluorobenzene	9.21
1-chloro-4-fluorobenzene	8.99
o-fluorotoluene	8.915
m-fluorotoluene	8.915
p-fluorotoluene	8.785
o-chlorotoluene	8.83
m-chlorotoluene	8.83
p-chlorotoluene	8.70
o-bromotoluene	8.79
m-bromotoluene	8.81
p-bromotoluene	8.67
o-iodotoluene	8.62
m-iodotoluene	8.61
p-iodotoluene	8.50
benzotrifluoride	9.68
o-fluorophenol	8.66

Heterocyclic Molecules

<u>Molecule</u>	<u>IP(eV)</u>
furan	8.89
2-methyl furan	8.39
2-furaldehyde	9.21
tetrahydrofuran	9.54
dihydropyran	8.34
tetrahydropyran	9.26
thiophene	8.860
2-chlorothiophene	8.68
2-bromothiophene	8.63
pyrrole	8.20
pyridine	9.32
2-picoline	9.02
3-picoline	9.04
4-picoline	9.04
2,3-lutidine	8.85
2,4-lutidine	8.85
2,6-lutidine	8.85

Miscellaneous Molecules

<u>Molecule</u>	<u>IP(eV)</u>
ethylene oxide	10.565
propylene oxide	10.22
p-dioxane	9.13
dimethoxymethane	10.00
diethoxymethane	9.70
1,1-dimethoxyethane	9.65
propiolactone	9.70
methyl disulfide	8.46
ethyl disulfide	8.27
diethyl sulfite	9.68
thiolacetic acid	10.00
acetyl chloride	11.02
acetyl bromide	10.55
cyclo-C ₆ H ₁₁ CF ₃	10.46
(n-C ₃ F ₇)(CH ₃)C=O	10.58
trichlorovinylsilane	10.79
(C ₂ F ₅) ₃ N	11.7
isoprene	9.08
phosgene	11.77

Notes:

Reference: HNu Systems, Inc., 1985

IP = Ionization Potential

ATTACHMENT 3

PID CALIBRATION AND MAINTENANCE LOG						
Instrument Model Number						
Instrument Serial Number						
Calibration Gas ppm						
Date/Time	Initials	Battery Check	Calibration			
			Background Value	True Gas Value	Measured Gas Value	Adjust
COMMENTS:						

Investigation-Derived Waste Handling and Storage

Rev. #: 2

Rev Date: March 6, 2009

Approval Signatures

Prepared by: Andrew Kamik Date: 3/6/09

Reviewed by: Jim Marsh Date: 3/6/09
(Technical Expert)

I. Scope and Application

The objective of this Standard Operating Procedure (SOP) is to describe the procedures to manage investigation-derived wastes (IDW), both hazardous and non-hazardous, generated during site activities, which may include, but are not limited to - drilling, trenching/excavation, construction, demolition, monitoring well sampling, soil sampling, decontamination and remediation. Please note that this SOP is intended for materials that have been deemed a solid waste as defined by 40 CFR § 261.2 (which may include liquids, solids, and sludges). In some cases, field determinations will be made based on field screening or previous data that materials are not considered a solid waste. IDW may include soil, groundwater, drilling fluids, decontamination liquids, personal protective equipment (PPE), sorbent materials, construction and demolition debris, and disposable sampling materials that may have come in contact with potentially impacted materials. IDW will be collected and staged at the point of generation. Quantities small enough to be containerized in 55-gallon drums will be taken to a designated temporary storage area (discussed in further detail under Drum Storage) onsite pending characterization and disposal. Waste materials will be analyzed for constituents of concern to evaluate proper disposal methods. PPE and disposable sampling equipment will be placed in DOT-approved drums prior to disposal and typically does not require laboratory analysis. This SOP describes the necessary equipment, field procedures, materials, regulatory references, and documentation procedures necessary for proper handling and storage of IDW up to the time it is properly disposed. The procedures for handling IDW are based on the United States Environmental Protection Agency's Guide to Management of Investigation Derived Wastes (USEPA, 1992). IDW is assumed to be contaminated with the site constituents of concern (COCs) until analytical evidence indicates otherwise. IDW will be managed to ensure the protection of human health and the environment and will comply with all applicable or relevant and appropriate requirements (ARAR). The following Laws and Regulations on Hazardous Waste Management are potential ARAR for this site.

State Laws and Regulations

- To Be Determined Based on Location of Site and Location of Treatment, Storage, and/or Disposal Facility (TSDF) to be utilized

Federal Laws and Regulations

- Resource Conservation and Recovery Act (RCRA) 42 USC § 6901-6987
- Comprehensive Environmental Response, Compensation and Liability Act (CERCLA) 42 USC § 9601-9675

- Superfund Amendments and Reauthorization Act (SARA)
- Department of Transportation (DOT) Hazardous Materials Transportation

Pending characterization, IDW will be stored appropriately within each area of contamination (AOC). Under RCRA, "storage" is defined as the holding of hazardous waste for a temporary period, at the end of which the hazardous waste is treated, disposed of, or stored elsewhere" (40 CFR § 260.10). The onsite waste staging area will be in a secure and controlled area. Waste characterization can either be based on generator knowledge, such as using materials safety data sheets (MSDS'), or can be based upon analytical results. The laboratory used for waste characterization analysis must have the appropriate state and federal certifications and be approved by ARCADIS and Client. IDW will be classified as RCRA hazardous or non-regulated under RCRA based on the waste characterization.

If IDW is characterized as RCRA hazardous waste, RCRA and DOT requirements must be followed for packaging, labeling, transporting, storing, and record keeping as described in 40 CFR § 262 and 49 CFR § 171-178. Wastes judged to potentially meet the criteria for hazardous wastes shall be stored in DOT approved packaging. Waste material classified as RCRA non-hazardous may be handled and disposed of as an industrial waste.

Liquid wastes judged to potentially meet the criteria for hazardous wastes shall be stored in DOT approved 55 gallon drums or other approved containers that are compatible with the type of material stored therein. Solid materials deemed to potentially meet hazardous criteria will be drummed where practicable. Large quantities of potentially hazardous solid materials must be containerized (such as in a roll-off box) for up to a maximum of 90 or 180 days as described in the Excavated Solids Section. Waste material classified as non-hazardous may be handled and disposed of as an industrial waste and is not subject to the 90-day or 180-day on-site storage limitation.

This is a standard (i.e., typically applicable) operating procedure which may be varied or changed as required, dependent upon site conditions, equipment limitations, or limitations imposed by the procedure. The ultimate procedure employed will be documented in the project work plans or reports. If changes to the sampling procedures are required due to unanticipated field conditions, the changes will be discussed with the Project Manager and Client as soon as practicable and documented in the report.

II. Personnel Qualifications

ARCADIS field sampling personnel will have current health and safety training including 40-hour HAZWOPER training, site supervisor training, site-specific training, first aid, and CPR, as needed. ARCADIS personnel may sign manifests on a case-to-case basis for clients, provided the appropriate agreement is in place between ARCADIS and the client documenting that ARCADIS is not the generator, but is acting as authorized representative for the generator. ARCADIS personnel who sign hazardous waste manifests will have the current DOT hazardous materials transportation training according to 49 CFR § 172.704. ARCADIS field personnel will also comply with client-specific training such as LPS. In addition, ARCADIS field sampling personnel will be versed in the relevant SOPs and possess the required skills and experience necessary to successfully complete the desired field work.

III. Equipment List

The following materials, as required, shall be available for IDW handling and storage:

Appropriate personal protective equipment as specified in the Site Health and Safety Plan

- 55-gallon steel drums, DOT 1A2 or equivalent
- $\frac{3}{4}$ -inch socket wrench
- Hammer
- Leather gloves
- Drum dolly
- Appropriate drum labels (outdoor waterproof self adhesive)
- Polyethylene storage tank
- Appropriate labeling, packing, chain-of-custody forms, and shipping materials as specified in the *Chain-of-Custody SOP* and *Field Sampling Handling, Packing, and Shipping SOP*.
- Indelible ink and/or permanent marking pens
- Plastic sheeting

- Appropriate sample containers, labels, and forms
- Stainless-steel bucket auger
- Stainless steel spatula or knife
- Stainless steel hand spade
- Stainless steel scoop
- Digital camera
- Field logbook.

IV. Cautions

- Filled drums can be very heavy, always use appropriate moving techniques and equipment.
- Similar media will be stored in the same drums to aid in sample analysis and disposal.
- Drum lids must be secured to prevent rainwater from entering the drums.
- Drums containing solid material may not contain any free liquids.
- Waste containers stored for extended periods of time may be subject to deterioration. Drum over packs may be used as secondary containment.
- All drums must be in good condition to prevent potential leakage and facilitate subsequent disposal. Inspect the drums for dents and rust, and verify the drum has a secure lid prior to use.

V. Health and Safety Considerations

- Appropriate personal protective equipment must be worn by all field personnel within the designated work area.
- Air monitoring may be required during certain field activities as required in the Site Health and Safety Plan.

- If excavating in potentially hazardous areas is possible, contingency plans should be developed to address the potential for encountering gross contamination or non-aqueous phase liquids.
- ARCADIS field personnel will be familiar and compliant with Client-specific health and safety requirements such as Chevron's hand safety policy including the prohibition of fixed and/or folding blade knives.

VI. Procedure

Waste storage and handling procedures to be used depend upon the type of generated waste. For this reason, IDW should be stored in a secure location onsite in separate 55-gallon storage drums, solids can be stockpiled onsite (if non-hazardous), and purge water may be stored in polyethylene tanks. Waste materials such as broken sample bottles or equipment containers and wrappings will be stored in 55-gallon drums unless they were not in contact with sample media.

Management of IDW

Minimization of IDW should be considered by the Project Manager during all phases of the project. Site managers may want to consider techniques such as replacing solvent-based cleaners with aqueous-based cleaners for decontamination of equipment, reuse of equipment (where it can be decontaminated), limitation of traffic between exclusion and support zones, and drilling methods and sampling techniques that generate little waste. Alternative drilling and subsurface sampling methods may include the use of small diameter boreholes, as well as borehole testing methods such as a core penetrometer or direct push technique instead of coring (EPA, 1993).

Drum Storage

Drums containing hazardous waste shall be stored in accordance with the requirements of 40 CFR 265 Subpart I (for containers) and 265 Subpart DD (for containment buildings). All 55-gallon drums will be stored at a secure, centralized on-site location that is readily accessible for vehicular pick-up. Drums confirmed as, or believed to contain hazardous waste will be stored over an impervious surface provided with secondary containment. The storage location will, for drums containing liquid, have a containment system that can contain at least the larger of 10% of the aggregate volume of staged materials or 100% of the volume of the largest container. Drums will be closed during storage and be in good condition in accordance with the Guide to Management of Investigation-Derived Wastes (USEPA, 1992).

Hazardous Waste Determination

Waste material must be characterized to determine if it meets any of the federal definitions of hazardous waste as required by 40 CFR § 262.11. If the waste does not meet any of the federal definitions, it must then be established if any state-specific hazardous waste criteria exist/apply.

Generator Status

Once hazardous waste determination has been made, the generator status will be determined. Large quantity generators (LQG) are generators who generate more than 1,000 kilograms of hazardous waste in a calendar month. Small quantity generators (SQG) of hazardous waste are generators who generate greater than 100 kilograms but less than 1,000 kilograms of hazardous waste in a calendar month. Conditionally exempt small quantity generators (CESQG) are generators who generate less than 100 kilograms of hazardous waste per month. Please note that a generator status may change from month to month and that a notice of this change is usually required by the generator's state agency.

Accumulation Time for Hazardous Waste

A LQG may accumulate hazardous waste on site for 90 days or less without a permit and without having interim status provided that such accumulation is in compliance with specifications in 40 CFR § 262.34. A SQG may accumulate hazardous waste on site for 180 days or less without a permit or without having interim status subject to the requirements of 40 CFR § 262.34(d). CESQG requirements are found in 40 CFR § 261.5. **NOTE:** The CESQG and SQG provisions of 40 CFR § 261.5, 262.20(e), 262.42(b) and 262.44 may not be recognized by some states (e.g. Rhode Island).

State-specific regulations must be reviewed and understood prior to the generation of hazardous waste.

Satellite Accumulation of Hazardous Waste

Satellite accumulation (SAA) shall mean the accumulation of as much as fifty-five (55) gallons of hazardous waste, or the accumulation of as much as one quart of acutely hazardous waste, in containers at or near any point of generation where the waste initially accumulates, which is under the control of the operator of the process generating the waste, without a permit or interim status and without complying with the requirements of 40 CFR § 262.34(a) and without any storage time limit, provided that the generator complies with 40 CFR § 262.34(c)(1)(i).

Once more than 55 gallons of hazardous waste accumulates in SAA, the generator has three days to move this waste into storage.

Storage recommendations for hazardous waste include:

- Ignitable Hazardous wastes must be >50 feet from the property line per 40 CFR § 265.176 (LQG generators only).
- Hazardous waste must be stored on a concrete slab (asphalt is acceptable if there are no free liquids in the waste) per 40 CFR § 265.176.
- Drainage must be directed away from the accumulation area.
- Area must be properly vented.
- Area must be secure.

Drum/Container Labeling

Drums will be labeled on both the side and lid of the drum using a permanent marking pen. Old drum labels must be removed to the extent possible, descriptions crossed out should any information remain, and new labels affixed on top of the old labels. Other containers used to store various types of waste (polyethylene tanks, roll-off boxes, end-dump trailers, etc.) will be labeled with an appropriate "Waste Container" or "Testing in Progress" label pending characterization. Drums and containers will be labeled as follows:

- Appropriate waste characterization label (Testing In Progress, Hazardous, or Non-Hazardous)
- Waste generator's name (e.g., client name)
- Project name
- Name and telephone number of ARCADIS project manager
- Composition of contents (e.g., used oil, acetone 40%, toluene 60%)
- Media (e.g., solid, liquid)
- Accumulation start date

- Drum number of total drums as reconciled with the Drum Inventory maintained in the field log book.

IDW containers will remain closed except when adding or removing waste. Immediately upon beginning to place waste into the drum/container, a "Waste Container" or "Testing in Progress" label will be filled out to include the information specified above, and affixed to the container. Once the contents of the container are identified as either non-hazardous or hazardous, the following additional labels will be applied. Containers with waste determined to be non-hazardous will be labeled with a green and white "Non-Hazardous Waste" label over the "Waste Container" label. Containers with waste determined to be hazardous will be stored in an onsite storage area and will be labeled with the "Hazardous Waste" label and affixed over the "Waste Container" label. The ACCUMULATION DATE for the hazardous waste is the date the waste is first placed in the container and is the same date as the date on the "Waste Container" label. DOT hazardous class labels must be applied to all hazardous waste containers for shipment offsite to an approved disposal or recycling facility. In addition a DOT proper shipping name shall be included on the hazardous waste label. The transporter should be equipped with the appropriate DOT placards. However, placarding or offering placards to the initial transporter is the responsibility of the generator per 40 CFR § 262.33.

Inspections and Documentation

All IDW will be documented as generated on a Drum Inventory Log maintained in the field log book. The Drum Inventory will record the generation date, type, quantity, matrix and origin (e.g. Boring-1, Test Pit 3, etc) of materials in every drum, as well as a unique identification number for each drum. The drum inventory will be used during drum pickup to assist with labeling of drums. The drum storage area and any other areas of temporarily staged waste, such as soil/debris piles, will be inspected weekly. The weekly inspections will be recorded in the field notebook or on a Weekly Inspection Log. Digital photographs will be taken upon the initial generation and drumming/staging of waste, and final labeling after characterization to document compliance with labeling and storage protocols, and condition of the container. Evidence of damage, tampering or other discrepancy should be documented photographically.

Emergency Response and Notifications

Specific procedures for responding to site emergencies will be detailed in the HASP. If the generator is designated as a LQG, a Contingency Plan will need to be prepared to include emergency response and notification procedures per 40 CFR § 265 Subpart D. In the event of a fire, explosion, or other release which could threaten human health

outside of the site or when Client or ARCADIS has knowledge of a spill that has reached surface water, Client or ARCADIS must immediately notify the National Response Center (800-424-8802) in accordance with 40 CFR § 262.34. Other notifications to state agencies may also be necessary.

Drilling Soil Cuttings and Muds

Soil cuttings are solid to semi-solid soils generated during trenching activities, subsurface soil sampling, or installation of monitoring wells. Depending on the drilling method, drilling fluids known as "muds" may be used to remove soil cuttings. Drilling fluids flushed from the borehole must be directed into a settling section of a mud pit. This allows reuse of the decanted fluids after removal of the settled sediments. Soil cuttings will be labeled and stored in 55-gallon drums with bolt-sealed lids.

Excavated Solids

Excavated solids may include, but are not limited to soil, fill and construction and demolition debris. Excavated solids may be temporarily stockpiled onsite as long as the material is a RCRA non-hazardous waste and the solids will be treated onsite pursuant to a certified, authorized, or permitted treatment method, or properly disposed off-site. Stockpiled materials characterized as hazardous must be immediately containerized and removed from the site within 90 days of generation (except for soils using satellite accumulation). Excavated solids should be stockpiled and maintained in a secure area onsite. At a minimum, the floor of the stockpile area will be covered with a 20-mil high density polyethylene liner that is supported by a foundation or at least a 60-mil high density polyethylene liner that is not supported by a foundation. The excavated material will not contain free liquids. The owner/operator will provide controls for windblown dispersion, run-on control, and precipitation runoff. The run-on control system will prevent flow onto the active portion of the pile during peak discharge from at least a 25-year storm and the run-off management system will collect and control at least the water volume resulting from a 24-hour, 25-year storm (EPA, 1992). Additionally, the stockpile area will be inspected on a weekly basis and after storm events. Individual states may require that the stockpile be inspected/certified by a licensed professional engineer. Stockpiled material will be covered with a 6-mil polyvinyl chloride (PVC) liner. The stockpile cover will be secured in place with appropriate material (concrete blocks, weights, etc.) to prevent the movement of the cover. Excavated solids may also be placed in roll off containers and covered with a 6-mil PVC liner pending results for waste characterization.

Decontamination Solutions

Decontamination solutions are generated during the decontamination of personal protective equipment and sampling equipment. Decontamination solutions may range from detergents, organic solvents and acids used to decontaminate small field sampling equipment to steam cleaning rinsate used to wash heavy field equipment. These solutions are to be labeled and stored in 55-gallon drums with bolt-sealed lids.

Disposable Equipment

Disposable equipment includes personal protective equipment (tyvek coveralls, gloves, booties and APR cartridges) and disposable sampling equipment such as trowels or disposable bailers. If the media sampled exhibits hazardous characteristics per results of waste characterization sampling, disposable equipment will also be disposed of as a hazardous waste. These materials will be stored onsite in labeled 55-gallon drums pending analytical results for waste characterization.

Purge Water

Purge water includes groundwater generated during well development, groundwater sampling, or aquifer testing. The volume of groundwater generated will dictate the appropriate storage procedure. Monitoring well development and groundwater sampling may generate three well volumes of groundwater or more. This volume will be stored in labeled 55-gallon drums. Aquifer tests may generate significantly greater volumes of groundwater depending on the well yield and the duration of the test. Therefore, large-volume portable polyethylene tanks will be considered for temporary storage pending groundwater-waste characterization.

Purged Water Storage Tank Decontamination and Removal

The following procedures will be used for inspection, cleaning, and offsite removal of storage tanks used for temporary storage of purge water. These procedures are intended to be used for rented portable tanks such as Baker Tanks or Rain for Rent containers. Storage tanks will be made of inert polyethylene materials.

The major steps for preparing a rented tank for return to a vendor include characterizing the purge water, disposing of the purge water, decontaminating the tank, final tank inspection, and mobilization. Decontamination and inspection procedures are describe in further detail below.

- Tank Cleaning: Most vendors require that tanks be free of any sediment and water before returning, a professional cleaning service may be required. Each

specific vendor should be consulted concerning specific requirements for returning tanks.

- Tank Inspection: After emptying the tank, purged water storage tanks should be inspected for debris, chemical staining, and physical damage. The vendors require that tanks be returned in the original condition (i.e., free of sediment, staining and no physical damage).

VII. Waste Characterization Sampling and Shipping

Soil/Solids Characterization

Waste characterization will be conducted in accordance with waste hauler, waste handling facility, and state/federal requirements. In general, RCRA hazardous wastes are those solid wastes determined by a Toxicity Characteristic Leaching Procedure (TCLP) test or to contain levels of certain toxic metals, pesticides, or other organic chemicals above specific federally regulated thresholds. If the one or more of 40 toxic compounds listed in Table I of 40 CFR § 261.24 are detected in the sample at levels above the maximum unregulated concentrations, the waste must be characterized as a toxic hazardous waste. Wastes can also be considered "listed" hazardous waste depending on site-specific processes.

Composite soil samples will be collected at a frequency of one sample per 10 cubic yard basis for stockpiled soil or one per 55-gallon drum for containerized. A four point composite sample will be collected per 10 cubic yards of stockpiled material and for each drum. Sample and composite frequencies may be adjusted in accordance with the waste handling facility's requirements. Waste characterization samples may be analyzed for the TCLP volatile organic compounds (VOCs), TCLP semi-volatile organic compounds (SVOCs), TCLP RCRA metals, and polychlorinated biphenyls, as well as corrosivity (pH), reactivity and flammability (flashpoint). Additional samples may be collected and analyzed by the laboratory on a contingency basis.

Wastewater Characterization

Waste characterization will be conducted in accordance with the requirements of the waste hauler, waste handling facility, and state/federal governments. In general, purge water should be analyzed by methods appropriate for the known contaminants, if any, that have been historically detected in the monitoring wells. Samples will be collected and analyzed in accordance with the requirements of the waste disposal facility.

Wastewater characterization samples may be analyzed for TCLP volatile organic compounds (VOCs), TCLP semi-volatile organic compounds (SVOCs), TCLP RCRA

metals, and polychlorinated biphenyls, as well as corrosivity (pH), reactivity and flammability (flashpoint). Additional samples may be collected and analyzed by the laboratory on a contingency basis.

Sample Handling and Shipping

All samples will be appropriately labeled, packed, and shipped, and the chain-of-custody will be filled out in accordance with the Chain-of-Custody SOP and Field Sampling Handling, Packing, and Shipping SOP and Hazardous Materials Packaging and Shipping SOP.

It should be noted that additional training is required for packaging and shipping of hazardous and/or dangerous materials. Please reference the following ARCADIS intranet team page for more information: <http://team/sites/hazmat/default.aspx>.

Preparing Waste Shipment Documentation (Hazardous and Non-Hazardous)

Waste profiles will be prepared by the ARCADIS PM and forwarded, along with laboratory analytical data to the Client PM for approval/signature. The Client PM will then return the profile to ARCADIS who will then forward to the waste removal contractor for preparation of a manifest. The manifest will be reviewed by ARCADIS prior to forwarding to the Client PM for approval. Upon approval of the manifest, the Client PM will return the original signed manifest directly to the waste contractor or to the ARCADIS PM for forwarding to the waste contractor.

Final drum labeling and pickup will be supervised by an ARCADIS representative who is experienced with waste labeling procedures. The ARCADIS representative will have a copy of the drum inventory maintained in the field book and will reconcile the drum inventory with the profile numbers on the labels and on the manifest. Different profile numbers will be generated for different matrices or materials in the drums. For example, the profile number for drill cuttings will be different than the profile number for purge water. **When there are multiple profiles it is critical that the proper label, with the profile number appropriate to a specific material be affixed to the proper drums.** A copy of the ARCADIS drum inventory will be provided to the waste transporter during drum pickup and to the facility receiving the waste.

VIII. Data Recording and Management

Waste characterization sample handling, packing, and shipping procedures will be documented in accordance with the *Quality Assurance Project Plan*, if one exists. Copies of the chains-of-custody forms will be maintained in the project file.

Following waste characterization, IDW containers will be re-labeled with the appropriate waste hazardous or non-hazardous waste labels and the client will initiate disposal at the appropriate waste disposal facility.

IX. Quality Assurance

The chain-of-custody and sample labels for waste characterization samples will be filled out in accordance with the *Quality Assurance Project Plan*.

X. References

United States Environmental Protection Agency (USEPA). 1992. Guide to Management of Investigation-Derived Wastes. Office of Remedial and Emergency Response. Hazardous Site Control Division. January 1992.

USEPA. 1991. *Guide to Discharging CERCLA Aqueous Wastes to Publicly Owned Treatment Works (POTWs)*. Office of Remedial and Emergency Response. Hazardous Site Control Division OS-220W. March 1991.

Field Log Book Entries

Rev. #: 0

Rev Date: 11 August 2009

Approval Signatures

Prepared by: Andrew Kamik Date: 8/11/09

Reviewed by: Michael J. Goff Date: 8/11/09
(Technical Expert)

I. Scope and Application

This ARCADIS Standard Operating Procedure covers the entries needed in a field log book for environmental investigations.

This SOP does not address all of the entries that may be needed for a specific project, and does not address health and safety, equipment decontamination, field parameter measurements, sample preservation, chain-of-custody, or laboratory analysis. For direction on requirements in these areas, refer to other ARCADIS SOPs, the project work plans including the quality assurance project plan, sampling plan, and health and safety plan, as appropriate.

II. Personnel Qualifications

ARCADIS personnel participating in fieldwork and making entries into the field log book should have a minimum of one (1) year of field experience (or be under the supervision and accompanied in the field by someone who does) and current health and safety training including 40-hour HAZWOPER training, site supervisor training, site-specific training, first aid, and CPR, as needed. Field personnel will also be compliant with client-specific training requirements. In addition, ARCADIS field sampling personnel will be versed in the relevant SOPs and possess the required skills and experience necessary to successfully complete the desired field work.

III. Equipment List

- Field Log Book
- Ball point (medium point) pen with blue or black ink (black preferred). A fine point Sharpie pen may be used if the ink does not bleed through the page and become visible on back side of the page. If weather conditions prevent the use of a pen, indicate so in the log and use an alternate writing instrument .
- Zip-lock baggie or other weather-proof container to protect the field log book from the elements.

IV. Cautions

All entries in the field log must be legible and archivable. Do not leave the field log book exposed to the elements or other conditions that might moisten the pages and smear/dissolve the entries. When not in the field, the log book should be stored in a location that is easily accessible to field crews.

V. Health and Safety Considerations

ARCADIS field personnel will be familiar and compliant with Client-specific health and safety requirements.

VI. Procedure

- Print legibly. Do not use cursive writing.
- The name of the project, project number and project location should be written in indelible ink on the outside of the field log book.
- On the inside of the front cover, write "If Found, Please Return to ARCADIS" and include the appropriate address and phone number, the name of the person to which the book is assigned, and the name of the project manager.
- Reserve the first page of the book for a Table of Contents.
- Reserve the last five (5) pages of the book for important contacts, notes, reminders, etc.
- Each day of field work, the following should be recorded in the field log book as applicable:
 - a) Project Name
 - b) Date and time arrived
 - c) Work Site Location
 - d) Names of people on-site related to the project including ARCADIS employees, visitors, subcontractor employees, agency personnel, client representative, etc.
 - e) Describe the work to be performed briefly, and list the equipment on-site
 - f) Indicate the health and safety (H&S) level to be used
 - g) Record instrument calibrations and checks
 - h) Record time and general content of H&S briefing
 - i) Describe the weather conditions, including temperature, precipitation, and wind speed and direction
 - j) List periodic time entries in the far left hand column of each page
 - k) Minimize unused space on each page
- The tailgate meeting must be recorded in the log book and the tailgate form completed. If H&S monitoring is performed, record the time and results of initial and followup monitoring.

- Note factual observations including collection of QA/QC samples, delays, well damage, accidents, work plan deviations, instrument problems, and problem resolutions.
- Describe work performed and how documented such as photographs, sample core logs, water sampling logs, etc.
- Describe bases for field decisions including pertinent conversations with visitors, regulators, or project personnel.
- Note final instrument calibrations and checks.
- Sign the log book at the end of each day at a minimum. Draw a line to the end of the page to indicate no further entries on that page. Sign the bottom of each page if possible.
- If an entry to the log book is changed, strike out the deleted text or item with a single line such that the entry remains legible, and initial and date the change. Such changes should only be made by the same person that made the initial entry.
- Field log book entries must be made in the field at the site, not at a later time at a different location. Supplemental entries to the log book may be made at a later date. The supplemental entry must be clearly identified as such and the entry must be signed and dated as described in this SOP.
- Problems noted in the field log book must be brought to the attention of the project manager and task manager in a timely fashion. Problems may be reported in person, on the telephone, or in a written daily log form. If daily logs are prepared and you will not be able to personally give the daily log to the project manager, send the daily log via FAX or overnight courier to the project manager and task manager.

VII. Waste Management

Investigation-derived waste will be managed as described in the Investigation-Derived Waste Handling and Storage SOP. A drum/waste inventory should be maintained on a pre-designated page in the field log book.

VIII. Data Recording and Management

Each page of the field log book should be scanned for electronic/digital archiving at periodic intervals. This will ensure that copies of the field notes are available in the event the field book is lost or damaged, and that field data can be easily disseminated to others without the risk of physically sending the field log book. Field log books that are full should be archived with the project files, and readily retrievable.

IX. Quality Assurance

Be mindful that the field log book may be produced in court. All entries should be legible (as discussed above). Entries should also be in English, unless working in a country where English is not the predominant language or you are directed otherwise by the project manager.

X. References

Not Applicable

Monitoring Well Installation

Rev. #: 3

Rev Date: February 2, 2011

Approval Signatures

Prepared by:  Date: 2/2/2011

Reviewed by:  Date: 2/2/2011
(Technical Expert)

I. Scope and Application

The procedures set out herein are designed to produce standard groundwater monitoring wells suitable for: (1) groundwater sampling, (2) water level measurement, (3) bulk hydraulic conductivity testing of formations adjacent to the open interval of the well.

Monitoring well boreholes in unconsolidated (overburden) materials are typically drilled using the hollow-stem auger drilling method. Other drilling methods that are also suitable for installing overburden monitoring wells, and are sometimes necessary due to site-specific geologic conditions, include: drive-and-wash, spun casing, Rotasonic, dual-rotary (Barber Rig), and fluid/mud rotary with core barrel or roller bit. Direct-push techniques (e.g., Geoprobe or cone penetrometer) and driven well points may also be used in some cases within the overburden. Monitoring wells within consolidated materials such as bedrock are commonly drilled using water-rotary (coring or tri-cone roller bit), air rotary or Rotasonic methods. The drilling method to be used at a given site will be selected based on site-specific consideration of anticipated drilling/well depths, site or regional geologic knowledge, type of monitoring to be conducted using the installed well, and cost.

No oils or grease will be used on equipment introduced into the boring (e.g., drill rod, casing, or sampling tools). No polyvinyl chloride (PVC) glue/cement will be used in constructing or retrofitting monitoring wells that will be used for water-quality monitoring. No coated bentonite pellets will be used in the well drilling or construction process. Specifications of materials to be installed in the well will be obtained prior to mobilizing onsite, including:

- well casing;
- bentonite;
- sand; and
- grout.

Well materials will be inspected and, if needed, cleaned prior to installation.

II. Personnel Qualifications

Monitoring well installation activities will be performed by persons who have been trained in proper well installation procedures under the guidance of an experienced field geologist, engineer, or technician. Where field sampling is performed for soil or

bedrock characterization, field personnel will have undergone in-field training in soil or bedrock description methods, as described in the appropriate SOP(s) for those activities.

III. Equipment List

The following materials will be available during soil boring and monitoring well installation activities, as required:

- Site Plan with proposed soil boring/well locations;
- Work Plan or Field Sampling Plan (FSP), and site Health and Safety Plan (HASP);
- personal protective equipment (PPE), as required by the HASP;
- traffic cones, delineators, caution tape, and/or fencing as appropriate for securing the work area, if such are not provided by drillers;
- appropriate soil sampling equipment (e.g., stainless steel spatulas, knife);
- soil and/or bedrock logging equipment as specified in the appropriate SOPs;
- appropriate sample containers and labels;
- drum labels as required for investigation derived waste handling;
- chain-of-custody forms;
- insulated coolers with ice, when collecting samples requiring preservation by chilling;
- photoionization detector (PID) or flame ionization detector (FID);
- ziplock style bags;
- water level or oil/water interface meter;
- locks and keys for securing the well after installation;
- decontamination equipment (bucket, distilled or deionized water, cleansers appropriate for removing expected chemicals of concern, paper towels);

- field notebook.

Prior to mobilizing to the site, ARCADIS personnel will contact the drilling subcontractor or in-house driller (as appropriate) to confirm that appropriate sampling and well installation equipment will be provided. Specifications of the sampling and well installation equipment are expected to vary by project, and so communication with the driller will be necessary to ensure that the materials provided will meet the project objectives. Equipment typically provided by the driller could include:

- drilling equipment required by the American Society of Testing and Materials (ASTM) D 1586, when performing split-spoon sampling;
- disposable plastic liners, when drilling with direct-push equipment;
- drums for investigation derived waste;
- drilling and sampling equipment decontamination materials;
- decontamination pad materials, if required; and
- well construction materials.

IV. Cautions

Prior to beginning field work, underground utilities in the vicinity of the drilling areas will be delineated by the drilling contractor or an independent underground utility locator service. See separate SOP for utility clearance.

Some regulatory agencies require a minimum annular space between the well or permanent casing and the borehole wall. When specified, the minimum clearance is typically 2 inches on all sides (e.g., a 2-inch diameter well requires a 6-inch diameter borehole). In addition, some regulatory agencies have specific requirements regarding grout mixtures. Determine whether the oversight agency has any such requirements prior to finalizing the drilling and well installation plan.

If dense non-aqueous phase liquids (DNAPL) are known or expected to exist at the site, refer to the DNAPL Contingency Plan SOP for additional details regarding drilling and well installation to reduce the potential for inadvertent DNAPL remobilization.

Similarly, if light non-aqueous phase liquids (LNAPLs) are known or expected to be present as “perched” layers above the water table, refer to the DNAPL Contingency

Plan. Follow the general provisions and concepts in the DNAPL contingency plan during drilling above the water table at known or expected LNAPL sites.

Avoid using drilling fluids or materials that could impact groundwater or soil quality, or could be incompatible with the subsurface conditions.

Similarly, consider the material compatibility between the well materials and the surrounding environment. For example, PVC well materials are not preferred when DNAPL is present. In addition, some groundwater conditions leach metals from stainless steel.

Water used for drilling and sampling of soil or bedrock, decontamination of drilling/sampling equipment, or grouting boreholes upon completion will be of a quality acceptable for project objectives. Testing of water supply should be considered.

Specifications of materials used for backfilling bore hole will be obtained, reviewed and approved to meet project quality objectives. Bentonite is not recommended where DNAPLs are likely to be present. In these situations, neat cement grout is preferred.

No coated bentonite pellets will be used in monitoring well construction, as the coating could impact the water quality in the completed well.

Monitoring wells may be installed with Schedule 40 polyvinyl chloride (PVC) to a maximum depth of 200 feet below ground surface (bgs). PVC monitoring wells between 200 and 400 feet total depth will be constructed using Schedule 80 PVC. Monitoring wells deeper than 400 feet will be constructed using steel.

V. Health and Safety Considerations

Field activities associated with monitoring well installation will be performed in accordance with a site-specific HASP, a copy of which will be present on site during such activities.

VI. Procedures

The procedures for installing groundwater monitoring wells are presented below:

Hollow-Stem Auger, Drive-and-Wash, Spun Casing, Fluid/Mud Rotary, Rotasonic, and Dual-Rotary Drilling Methods

1. Locate boring/well location, establish work zone, and set up sampling equipment decontamination area.

2. Advance boring to desired depth. Collect soil and/or bedrock samples at appropriate interval as specified in the Work Plan and/or FSP. Collect, document, and store samples for laboratory analysis as specified in the Work Plan and/or FSP. Decontaminate equipment between samples in accordance with the Work Plan and/or FSP. A common sampling method that produces high-quality soil samples with relatively little soil disturbance is the ASTM D 1586 - Standard Test Method for Penetration Test and Split-Barrel Sampling of Soils. Split-spoon samples are obtained during drilling using hollow-stem auger, drive-and-wash, spun casing, and fluid/mud rotary. Rotasonic drilling produces large-diameter soil cores that tend to be more disturbed than split-spoon samples due to the vibratory action of the drill casing. Dual-rotary removes cuttings by compressed air and allows only a general assessment of geology. High-quality bedrock samples can be obtained by coring.
3. Describe each soil or bedrock sample as outlined in the appropriate SOP. Record descriptions in the field notebook and/or personal digital assistant (PDA). It should be noted that PDA logs must be electronically backed up and transferred to a location accessible to other project team members as soon as feasible to retain and protect the field data. During soil boring advancement, document all drilling events in field notebook, including blow counts (number of blows required to advance split-spoon sampler in 6-inch increments) and work stoppages. Blow counts will not be available if Rotasonic, dual-rotary, or direct-push methods are used. When drilling in bedrock, the rate of penetration (minutes per foot) is recorded.
4. If it is necessary to install a monitor well into a permeable zone below a confining layer, particularly if the deeper zone is believed to have water quality that differs significantly from the zone above the confining layer, then a telescopic well construction should be considered. In this case, the borehole is advanced approximately 3 to 5 feet into the top of the confining layer, and a permanent casing (typically PVC, black steel or stainless steel) is installed into the socket drilled into the top of the confining layer. The casing is then grouted in place. The preferred methods of grouting telescoping casings include: pressure-injection grouting using an inflatable packer installed temporarily into the base of the casing, such that grout is injected out the bottom of the casing until it is observed at ground surface outside the casing; displacement-method grouting (also known as the Halliburton method), which entails filling the casing with grout and displacing the grout out the bottom of the casing by pushing a drillable plug, typically made of wood to the bottom of the casing, following by tremie grouting the remainder of the annulus outside the casing; or tremie grouting the annulus surrounding the casing using a tremie pipe installed to the base of the borehole. In all three cases, the casing is grouted to the ground

surface, and the grout is allowed to set prior to drilling deeper through the casing. Site-specific criteria and work plans should be created for the completion of non-standard monitoring wells, including telescopic wells.

5. In consolidated formations such as competent bedrock, a monitoring well may be completed with an open borehole interval without a screen and sandpack. In these cases, the borehole is advanced to the targeted depth of the top of the open interval. A permanent casing is then grouted in place following the procedures described in Step 4 above. After the grout sets, the borehole is advanced by drilling through the permanent casing to the targeted bottom depth of the open interval, which then serves as the monitoring interval for the well. If open-borehole interval stability is found to be questionable or if a specific depth interval is later selected for monitoring, a screened monitoring well may later be installed within the open-borehole interval, depending on the annular space and well diameter requirements.
6. Before installing a screened well – or after drilling an open-bedrock well –, it is important to confirm that the borehole has been advanced into the saturated zone. This is particularly important for wells installed to monitor the water table and/or the shallow saturated zone, as the capillary fringe may cause soils above the water table to appear saturated. If one or more previously installed monitoring wells exist nearby, use the depth to water at such well(s) to estimate the water-table depth at the new borehole location.

To verify that the borehole has been advanced into the saturated zone, it is necessary to measure the water level in the borehole. For boreholes drilled without using water (e.g., hollow-stem auger, cable-tool, air rotary, air hammer), verify the presence of groundwater (and /or LNAPL, if applicable) in the borehole using an electronic water level probe, oil-water interface probe, or a new or decontaminated bailer. For boreholes drilled using water (e.g., drive and wash, spun-casing with roller-bit wash, rotasonic, or water rotary with core or roller bit), monitor the water level in the borehole as it re-equilibrates to the static level. In low-permeability units like clay, fine-grained glacial tills, shale and other bedrock formations, it may be necessary to wait overnight to allow the water level to equilibrate. To the extent practicable, ensure that the depth of the well below the apparent water table is deep enough so that the installed well can monitor groundwater year-round, accounting for seasonal water-table fluctuations. In most cases, the well should be installed at least five feet below the water-table depth, determined as described above. When in doubt, err on the side of slightly deeper well installation.

If necessary, the borehole should be drilled deeper to ensure that the well may intersect the water table or a permeable water-bearing zone.

7. Upon completing the borehole to the desired depth, if a screened well construction is desired, install the monitoring well by lowering the screen and casing assembly with sump through the augers or casing. Monitoring wells typically will be constructed of 2-inch-diameter, flush-threaded PVC or stainless steel slotted well screen and blank riser casing. Smaller diameters may be used if wells are installed using direct-push methodology or if multiple wells are to be installed in a single borehole. The screen length will be specified in the Work Plan or FSP based on regulatory requirements and specific monitoring objectives. Monitoring well screens are usually 5 to 10 feet long, but may be up to 25 feet long in very low permeability, thick geologic formations. The screen length will depend on the purpose for the well and the objectives of the groundwater investigation. Typically, the slot size will be 0.010 inch and the sand pack will be 20-40, Morie No. 0, or equivalent. In very fine-grained formations where sample turbidity needs to be minimized, it may be preferred to use a 0.006-inch slot size and 30-65, Morie No. 00, or equivalent sand pack. Alternatively, where monitoring wells are installed in coarse-grained deposits and higher well yield is required, a 0.020-inch slot size and 10-20, Morie No. 1, or equivalent sand pack may be preferred. To the extent practicable, the slot size and sand pack gradation may be predetermined in the Work Plan or FSP based on site-specific grain-size analysis or other geologic considerations or monitoring objectives. A blank sump may be attached below the well screen if the well is being installed for DNAPL recovery/monitoring purposes. If so, the annular space around the sump will be backfilled with neat cement grout to the bottom of the well screen prior to placing the sand pack around the screen. A blank riser will extend from the top of the screen to approximately 2.5 feet above grade or, if necessary, just below grade where conditions warrant a flush-mounted monitoring well. For wells greater than 50 feet deep, centralizers may be desired to assist in centralizing the monitoring well in the borehole during construction.
8. When the monitoring well assembly has been set in place and the grout has been placed around the sump (if any), place a washed silica sand pack in the annular space from the bottom of the boring to a height of 1 to 2 feet above the top of the well screen. The sand pack is placed and drilling equipment extracted in increments until the top of the sand pack is at the appropriate depth. The sand pack will be consistent with the screen slot size and the soil particle size in the screened interval, as specified in the Work Plan or FSP. A hydrated bentonite seal (a minimum of 2 feet thick) will then be placed in the annular space above the sand pack. If non-hydrated bentonite is used, the bentonite

should be permitted to hydrate in place for a minimum of 30 minutes before proceeding. No coated bentonite pellets will be used in monitoring well drilling or construction. Potable water may be added to hydrate the bentonite if the seal is above the water table. Monitor the placement of the sand pack and bentonite with a weighted tape measure. During the extraction of the augers or casing, a cement/bentonite or neat cement grout will be placed in the annular space from the bentonite seal to a depth approximately 2 feet bgs.

9. Place a locking, steel protective casing (extended at least 1.5 feet below grade and 2 feet above grade) over the riser casing and secure with a neat cement seal. Alternatively, for flush-mount completions, place a steel curb box with a bolt-down lid over the riser casing and secure with a neat cement seal. In either case, the cement seal will extend approximately 1.5 to 2.0 feet below grade and laterally at least 1 foot in all directions from the protective casing, and should slope gently away to promote drainage away from the well. Monitoring wells will be labeled with the appropriate designation on both the inner and outer well casings or inside of the curb box lid.

When an above-grade completion is used, the PVC riser will be sealed using an expandable locking plug and the top of the well will be vented by drilling a small-diameter (1/8 inch) hole near the top of the well casing or through the locking plug, or by cutting a vertical slot in the top of the well casing. When a flush-mount installation is used, the PVC riser will be sealed using an unvented, expandable locking plug.

10. During well installation, record construction details and actual measurements relayed by the drilling contractor and tabulate materials used (e.g., screen and riser footages; bags of bentonite, cement, and sand) in the field notebook.
11. After completing the well installation, lock the well, clean the area, and dispose of materials in accordance with the procedures outlined in Section VII below.

Direct-Push Method

The direct-push drilling method may also be used to complete soil borings and install monitoring wells. Examples of this technique include the Diedrich ESP vibratory probe system, GeoProbe®, or AMS Power Probe® dual-tube system. Environmental probe systems typically use a hydraulically operated percussion hammer. Depending on the equipment used, the hammer delivers 140- to 350-foot pounds of energy with each blow. The hammer provides the force needed to penetrate very stiff/medium dense soil formations. The hammer simultaneously advances an outer steel casing that contains a dual-tube liner for sampling soil. The outside diameter (OD) of the outer

casing ranges from 1.75 to 2.4 inches and the OD of the inner sampling tube ranges from 1.1 to 1.8 inches. The outer casing isolates shallow layers and permits the unit to continue to probe at depth. The double-rod system provides a borehole that may be tremie-grouted from the bottom up. Alternatively, the inside diameter (ID) of the steel casing provides clearance for the installation of small-diameter (e.g., 0.75- to 1-inch ID) micro-wells. The procedures for installing monitoring wells in soil using the direct-push method are described below.

1. Locate boring/well location, establish work zone, and set up sample equipment decontamination area.
2. Advance soil boring to designated depth, collecting samples at intervals specified in the Work Plan. Samples will be collected using dedicated, disposable, plastic liners. Describe samples in accordance with the procedures outlined in Step 3 above. Collect samples for laboratory analysis as specified in the Work Plan and/or FSP.
3. Upon advancing the borehole to the desired depth, install the micro-well through the inner drill casing. The micro-well will consist of approximately 1-inch ID PVC or stainless steel slotted screen and blank riser. The sand pack, bentonite seal, and cement/bentonite grout will be installed as described, where applicable, in Step 7 and 8 above.
4. Install protective steel casing or flush-mount, as appropriate, as described in Step 9 above. During well installation, record construction details and tabulate materials used.
5. After completing the well installation, lock the well, clean the area, and dispose of materials in accordance with the procedures outlined in Section VII below.

Driven Well Point Installation

Well points will be installed by pushing or driving using a drilling rig or direct-push rig, or hand-driven where possible. The well point construction materials will consist of a 1- to 2-inch-diameter threaded steel casing with either 0.010- or 0.020-inch slotted stainless steel screen. The screen length will vary depending on the hydrogeologic conditions of the site. The casings will be joined together with threaded couplings and the terminal end will consist of a steel well point. Because they are driven or pushed to the desired depth, well points do not have annular backfill materials such as sand pack or grout.

VII. Waste Management

Investigation-derived wastes (IDW), including soil cuttings and excess drilling fluids (if used), decontamination liquids, and disposable materials (well material packages, PPE, etc.), will be placed in clearly labeled, appropriate containers, or managed as otherwise specified in the Work Plan, FSP, and/or IDW management SOP.

VIII. Data Recording and Management

Drilling activities will be documented in a field notebook. Pertinent information will include personnel present on site, times of arrival and departure, significant weather conditions, timing of well installation activities, soil descriptions, well construction specifications (screen and riser material and diameter, sump length, screen length and slot size, riser length, sand pack type), and quantities of materials used. In addition, the locations of newly-installed wells will be documented photographically or in a site sketch. If appropriate, a measuring wheel or engineer's tape will be used to determine approximate distances between important site features.

The well or piezometer location, ground surface elevation, and inner and outer casing elevations will be surveyed using the method specified in the site Work Plan. Generally, a local baseline control will be set up. This local baseline control can then be tied into the appropriate vertical and horizontal datum, such as the National Geodetic Vertical Datum of 1929 or 1988 and the State Plane Coordinate System. At a minimum, the elevation of the top of the inner casing used for water-level measurements should be measured to the nearest 0.01 foot. Elevations will be established in relation to the National Geodetic Vertical Datum of 1929. A permanent mark will be placed on top of the inner casing to mark the point for water-level measurements.

IX. Quality Assurance

All drilling equipment and associated tools (including augers, drill rods, sampling equipment, wrenches, and any other equipment or tools) that may have come in contact with soil will be cleaned in accordance with the procedures outlined in the appropriate SOP. Well materials will also be cleaned prior to well installation.

X. References

American Society of Testing and Materials (ASTM) D 1586 - *Standard Test Method for Penetration Test and Split-Barrel Sampling of Soils.*

Monitoring Well Development

Rev. #: 2.2

Rev. Date: March 22, 2010

Approval Signatures

Prepared by:  Date: 03/22/2010

Reviewed by:  Date: 03/22/2010
(Technical Expert)

I. Scope and Application

Monitoring wells (or piezometers, well points, or micro-wells) will be developed to clear them of fine-grained sediment to enhance the hydraulic connection between the well and the surrounding geologic formation. Development will be accomplished by evacuating well water by either pumping or bailing. Prior to pumping or bailing, the screened interval will be gently surged using a surge block, bailer, or inertia pump with optional surgeblock fitting as appropriate. Accumulated sediment in the bottom of the well (if present) will be removed by bailing with a bottom-loading bailer or via pumping using a submersible or inertia pump with optional surge-block fitting. Wells will also be gently brushed with a weighted brush to assist in removing loose debris, silt or flock attached to the inside of the well riser and/or screen prior to development. Pumping methods will be selected based on site-specific geologic conditions, anticipated well yield, water table depth, and groundwater monitoring objectives, and may include one or more of the following:

- submersible pump
- inertial pump (Waterra™ pump or equivalent)
- bladder pump
- peristaltic pump
- centrifugal pump

When developing a well using the pumping method, the pump (or, with inertial pumps, the tubing) is lowered to the screened portion of the well. During purging, the pump or tubing is moved up and down the screened interval until the well yields relatively clear water.

Submersible pumps have a motor-driven impeller that pushes the groundwater through discharge tubing to the ground surface. Inertial pumps have a check valve at the bottom of stiff tubing which, when operated up and down, lifts water to the ground surface. Bladder pumps have a bottom check valve and a flexible internal bladder that fills from below and is then compressed using pressurized air to force water out the top of the bladder through the discharge tubing to the ground surface. These three types of pumps have a wide range of applicability in terms of well depth and water depth.

Centrifugal and peristaltic pumps use atmospheric pressure to lift water from the well, and therefore can only be practically used where the depth to water is less than 25 feet.

II. Personnel Qualifications

Monitoring well development activities will be performed by persons who have been trained in proper well development procedures under the guidance of an experienced field geologist, engineer, or technician.

III. Equipment List

Materials for monitoring well development using a pump include the following:

- health and safety equipment, as required by the site Health and Safety Plan (HASP):
- cleaning equipment
- photoionization detector (PID) to measure headspace vapors
- pump
- polyethylene pump discharge tubing
- plastic sheeting
- power source (generator or battery)
- field notebook and/or personal digital assistant (PDA)
- graduated pails
- appropriate containers

- monitoring well keys
- water level indicator

Materials for monitoring well development using a bailer include the following:

- personal protective equipment (PPE) as required by the HASP
- cleaning equipment
- PID to measure headspace vapors
- bottom-loading bailer, sand bailer
- polypropylene or nylon rope
- plastic sheeting
- graduated pails
- appropriate containers
- keys to wells
- field notebook and/or PDA
- water level indicator
- weighted brush for well brushing

IV. Cautions

Where surging is performed to assist in removing fine-grained material from the sand pack, surging must be performed in a gentle manner. Excessive suction could promote fine-grained sediment entry into the outside of the sand pack from the formation.

Avoid using development fluids or materials that could impact groundwater or soil quality, or could be incompatible with the subsurface conditions.

In some cases it may be necessary to add potable water to a well to allow surging and development, especially for new monitoring wells installed in low permeability formations. Before adding potable water to a well, the Project Manager (PM) must be notified and the PM shall make the decision regarding the appropriateness and applicability of adding potable water to a well during well development procedures. If potable water is to be added to a well as part of development, the potable water source should be sampled and analyzed for constituents of concern, and the results evaluated by the PM prior to adding the potable water to the well. If potable water is added to a well for development purposes, at the end of development the well will be purged dry to remove the potable water, or if the well no longer goes dry then the well will be purged to remove at least three times the volume of potable water that was added.

V. Health and Safety Considerations

Field activities associated with monitoring well development will be performed in accordance with a site-specific HASP, a copy of which will be present on site during such activities.

VI. Procedure

The procedures for monitoring well development are described below. (Note: Steps 7, 8, and 10 can be performed at the same time using an inertial pump with a surge-block fitting.)

1. Don appropriate PPE (as required by the HASP).
2. Place plastic sheeting around the well.
3. Clean all equipment entering each monitoring well, except for new, disposable materials that have not been previously used.

4. Open the well cover while standing upwind of the well, remove well cap. Insert PID probe approximately 4 to 6 inches into the casing or the well headspace and cover with gloved hand. Record the PID reading in the field notebook. If the well headspace reading is less than 5 PID units, proceed; if the headspace reading is greater than 5 PID units, screen the air within the breathing zone. If the PID reading in the breathing zone is below 5 PID units, proceed. If the PID reading is above 5 PID units, move upwind from well for 5 minutes to allow the volatiles to dissipate. Repeat the breathing zone test. If the reading is still above 5 PID units, don the appropriate respiratory protection in accordance with the requirements of the HASP. Record all PID readings.
5. Obtain an initial measurement of the depth to water and the total well depth from the reference point at the top of the well casing. Record these measurements in the field log book.
6. Prior to redeveloping older wells that may contain solid particulate debris along the inside of the well casing and screen, gently lower and raise a weighted brush along the entire length of the well screen and riser to free and assist in removing loose debris, silt or flock. Perform a minimum of 4 "passes" along the screened and cased intervals of the well below the static water level in the well. Allow the resulting suspended material to settle for a minimum of one day prior to continuing with redevelopment activities.
7. Lower a surge block or bailer into the screened portion of the well. Gently raise and lower the surge block or bailer within the screened interval of the well to force water in and out of the screen slots and sand pack. Continue surging for 15 to 30 minutes.
8. Lower a bottom-loading bailer, submersible pump, or inertia pump tubing with check valve to the bottom of the well and gently bounce the bailer, pump, pump tubing on the bottom of the well to collect/remove accumulated sediment, if any. Remove and empty the bailer, if used. Repeat until the bailed/pumped water is free of excessive sediment and the bottom of the well feels solid. Alternatively, measurement of the well depth with a water level indicator can be used to verify that sediment and/or silt has been removed to the extent practicable, based on a comparison with the well installation log or previous measurement of total well depth.
9. After surging the well and removing excess accumulated sediment from the bottom of the well, re-measure the depth-to-water and the total well depth from the reference point at the top of the well casing. Record these measurements in the field log book.
10. Remove formation water by pumping or bailing. Where pumping is used, measure and record the pre-pumping water level. Operate the pump at a relatively constant rate. Measure the pumping rate using a calibrated container and stop watch, and record the pumping rate in the field log book. Measure and record the water level in the well at least

once every 5 minutes during pumping. Note any relevant observations in terms of water color, visual level of turbidity, sheen, odors, etc. Pump or bail until termination criteria specified in the Field Sampling Plan (FSP) are reached. Record the total volume of water purged from the well.

11. If the well goes dry, stop pumping or bailing. Note the time that the well went dry. After allowing the well to recover, note the time and depth to water. Resume pumping or bailing when sufficient water has recharged the well.
12. Contain all water in appropriate containers.
13. When complete, secure the lid back on the well.
14. Place disposable materials in plastic bags for appropriate disposal and decontaminate reusable, downhole pump components and/or bailer.

VII. Waste Management

Materials generated during monitoring well installation and development will be placed in appropriate labeled containers and disposed of as described in the Work Plan or Field Sampling Plan.

VIII. Data Recording and Management

Well development activities will be documented in a proper field notebook and/or PDA. Pertinent information will include personnel present on site; times of arrival and departure; significant weather conditions; timing of well development activities; development method(s); observations of purge water color, turbidity, odor, sheen, etc.; purge rate; and water levels before and during pumping.

IX. Quality Assurance

All reused, non-disposable, downhole well development equipment will be cleaned in accordance with the procedures outlined in the Field Equipment Cleaning-Decontamination SOP.

X. References

Not applicable.

Soil Drilling and Sample Collection

Rev. #: 3

Rev Date: September 26, 2014

Approval Signatures

Prepared by: Caron Koff Date: 03/08/2011

Reviewed by: Michael J. Seftell Date: 03/08/2011
(Technical Expert)

Reviewed by: Eric Killenbeck Date: 09/26/2014
(Eric Killenbeck)

I. Scope and Application

Overburden drilling is commonly performed using the hollow-stem auger drilling method. Other drilling methods suitable for overburden drilling, which are sometimes necessary due to site-specific geologic conditions, include: drive-and-wash, spun casing, Rotasonic, dual-rotary (Barber Rig), and fluid/mud rotary. Direct-push techniques (e.g., Geoprobe or cone penetrometer) may also be used. The drilling method to be used at a given site will be selected based on site-specific consideration of anticipated drilling depths, site or regional geologic knowledge, types of sampling to be conducted, required sample quality and volume, and cost.

No oils or grease will be used on equipment introduced into the boring (e.g., drill rod, casing, or sampling tools).

II. Personnel Qualifications

The Project Manager (a qualified geologist, environmental scientist, or engineer) will identify the appropriate soil boring locations, depth and soil sample intervals in a written plan.

Personnel responsible for overseeing drilling operations must have at least 16 hours of prior training overseeing drilling activities with an experienced geologist, environmental scientist, or engineer with at least 2 years of prior experience.

III. Equipment List

The following materials will be available during soil boring and sampling activities, as required:

- Site Plan with proposed soil boring/well locations;
- Work Plan or Field Sampling Plan (FSP), and site Health and Safety Plan (HASP);
- personal protective equipment (PPE), as required by the HASP;
- drilling equipment required by the American Society for Testing and Materials (ASTM) D 1586, when performing split-spoon sampling;
- disposable plastic liners, when drilling with direct-push equipment;
- appropriate soil sampling equipment (e.g., stainless steel spatulas, knife);

- equipment cleaning materials;
- appropriate sample containers and labels;
- chain-of-custody forms;
- insulated coolers with ice, when collecting samples requiring preservation by chilling;
- photoionization detector (PID) or flame ionization detector (FID); and
- field notebook and/or personal digital assistant (PDA).

IV. Cautions

Prior to beginning field work, the ARCADIS utility policy must be review and implemented. The ARCADIS utility location policy is outlined on the Health and Safety Team Site (<http://apex/HS/Pages/default.aspx>).

Avoid using drilling fluids or materials that could impact groundwater or soil quality, or could be incompatible with the subsurface conditions or a remediation design. The quality of water used for drilling should also be taken into consideration.

Water used for drilling and sampling of soil or bedrock, decontamination of drilling/sampling equipment, or grouting boreholes upon completion will be of a quality acceptable for project objectives. Testing of water supply should be considered.

Specifications of materials used for backfilling of a bore hole will be obtained, reviewed and approved to meet state and/or federal requirements, as well as project quality objectives.

V. Health and Safety Considerations

Field activities associated with drilling will be performed in accordance with a site-specific Health and Safety Plan (HASP), a copy of which will be present on site during such activities.

VI. Procedure

Drilling Procedures

The drilling contractor will be responsible for obtaining accurate and representative samples; informing the supervising geologist of changes in drilling pressure; and keeping a separate general log of soils encountered, including blow counts (i.e., the number of blows from a soil sampling drive weight [140 pounds] required to drive the split-barrel sampler in 6-inch increments). The term "samples" means soil materials from particular depth intervals, whether or not portions of these materials are submitted for laboratory analysis. Records will also be kept of occurrences of premature refusal due to boulders or construction materials that may have been used as fill. Where a boring cannot be advanced to the desired depth, the boring will be abandoned and an additional boring will be advanced at an adjacent location to obtain the required sample. Where it is desirable to avoid leaving vertical connections between depth intervals, the borehole will be sealed using cement and/or bentonite. Multiple refusals may lead to a decision by the supervising geologist to abandon that sampling location.

Soil Characterization Procedures

Soils encountered while drilling soil borings will be collected using one of the following methods:

- 2-inch split-barrel (split-spoon) sampler, if using the ASTM D 1586 - Standard Test Method for Penetration Test and Split-Barrel Sampling of Soils
- Plastic internal soil sample sleeves if using direct-push drilling.

Soils are typically field screened with an FID or PID at sites where volatile organic compounds are present in the subsurface. Field screening is performed using one of the following methods:

- Upon opening the sampler, the soil is split open and the PID or FID probe is placed in the opening and covered with a gloved hand. Such readings should be obtained at several locations along the length of the sample
- A portion of the collected soil is placed in a jar, which is covered with aluminum foil, sealed, and allowed to warm to room temperature. After warming, the cover is removed, the foil is pieced with the FID or PID probe, and a reading is obtained.

Samples selected for laboratory analysis will be handled, packed, and shipped in accordance with the procedures outlined in the Work Plan, FSP, or Chain-of-Custody, Handling, Packing, and Shipping SOP.

A geologist will be onsite during drilling and sampling operations to describe each soil interval on the soil boring log, including:

- percent recovery;
- structure and degree of sample disturbance;
- soil type;
- color;
- moisture condition;
- density;
- grain-size;
- consistency; and
- other observations, particularly relating to the presence of waste materials

Further details regarding geologic description of soils are presented in the Soil Description SOP.

Particular care will be taken to fully describe any sheens observed, oil saturation, staining, discoloration, evidence of chemical impacts, or unnatural materials.

VII. Waste Management

Water generated during cleaning procedures will be collected and contained onsite in appropriate containers for future analysis and appropriate disposal.

PPE (such as gloves, disposable clothing, and other disposable equipment) resulting from personnel cleaning procedures and soil sampling/handling activities will be placed in plastic bags. These bags will be transferred into appropriately labeled 55-gallon drums or a covered roll-off box for appropriate disposal.

Soil materials will be placed in sealed 55-gallon steel drums or covered roll-off boxes and stored in a secured area. Once full, the material will be analyzed to determine the appropriate disposal method.

VIII. Data Recording and Management

The supervising geologist or scientist will be responsible for documenting drilling events using a bound field notebook and/or PDA to record all relevant information in a clear and concise format. The record of drilling events will include:

- start and finish dates of drilling;
- name and location of project;
- project number, client, and site location;
- sample number and depths;
- blow counts and recovery;
- depth to water;
- type of drilling method;
- drilling equipment specifications, including the diameter of drilling tools;
- documentation of any elevated organic vapor readings;
- names of drillers, inspectors, or other people onsite; and
- weather conditions.

IX. Quality Assurance

Equipment will be cleaned prior to use onsite, between each drilling location, and prior to leaving the site. Drilling equipment and associated tools, including augers, drill rods, sampling equipment, wrenches, and other equipment or tools that may have come in contact with soils and/or waste materials will be cleaned with high-pressure steam-cleaning equipment using a potable water source. The drilling equipment will be cleaned in an area designated by the supervising engineer or geologist that is located outside of the work zone. More elaborate cleaning procedures may be required for reusable soil samplers (split-spoons) when soil samples are obtained for laboratory analysis of chemical constituents.

X. References

American Society of Testing and Materials (ASTM) D 1586 - *Standard Test Method for Penetration Test and Split-Barrel Sampling of Soils.*



Appendix G

Air Sparge System Design
Calculations

Appendix G - Air Sparge System Design Calculations

Estimated Formation Fracture Pressure										
Equations										
$P_F = P_{soil} + P_{water} = (d_s)(SG_s)(1-\theta)(\delta_w) + (d_s-d_{wt})(SG_w)(\theta)(\delta_w)$										
where: P_{soil} = pressure component due to soil column P_{water} = pressure component due to water column d_s = depth from ground surface to top of well screen SG_s = specific gravity of soil = 1.73 (assumed for sand and gravel mixture) θ = soil porosity = 0.25 (assumed for medium to fine grained Sand Mixture) δ_w = specific weight of water = 62.5 lb/ft ³ d_{wt} = maximum depth to static water table SG_w = specific gravity of water = 1 (assumed)										
Reference										
USACE 2008. Engineering Design, In-Situ Air Sparging, EM 1110-1-4005, January 31, 2008.										
Calculations										
Air Sparge Well	Screen Int (ft bgs)	d_s (ft)	d_{wt} (ft)	SG_s	SG_w	θ	δ_w (lb/ft ³)	P_{soil} (psi)	P_{water} (psi)	P_F (psi)
AS-1	13-15	13	5.00	1.73	1	0.25	62.5	7.3	0.9	8.2

Formation Break out Pressure Calculation

Equations

$$P_h = (D_w) * g * (ds - dwt)$$

where: P_h = hydrostatic pressure

d_s = depth from ground surface to top of well screen

D_w = Density of water = 1.94 slugs/ft³

dwt = depth of static water table

g = gravity = 32.2 ft/s²

Reference

USACE 2008. Engineering Design, In-Situ Air Sparging, EM 1110-1-4005, January 31, 2008.

Calculations

Air Sparge Well	Screen Int (ft bgs)	Dw (slugs/ft ³)	g (ft/s ²)	ds (ft)	dwt (ft)	P _h (psi)	Increases due to minor components ⁽¹⁾ (psi)	P _h Final (psi)
AS-1	13-15	1.94	32.2	13	5.00	3.5	0.5	4.0

Notes

(1) Minor components of breakout pressure include: piping friction losses, filterpack entry pressure, formation entry pressure.



Appendix H

SEPA Environmental Checklist

WAC 197-11-970 Determination of nonsignificance (DNS).

DETERMINATION OF NONSIGNIFICANCE

Description of proposal: Cleanup actions will be conducted at the Unocal Edmonds Bulk Fuel Terminal Site. This Site is being cleaned up under the authority of the Model Toxics Control Act, Ch 70.105D RCW, and the Model Toxics Control Action Cleanup Regulation, Chapter 173-340 WAC. The proposed cleanup action will excavate petroleum-contaminated soil from one area of the Site and will use Dual-Phase Extraction technology to clean up petroleum in another area adjacent to a storm drain.

Proponent: Chevron Environmental Management Company for Union Oil Company of California (Unocal)

Location of proposal, including street address, if any: 11720 Unoco Road, Edmonds, Washington 98020

Lead agency: Washington State Department of Ecology

The lead agency for this proposal has determined that it does not have a probable significant adverse impact on the environment. An environmental impact statement (EIS) is not required under RCW 43.21C.030 (2)(c). This decision was made after review of a completed environmental checklist and other information on file with the lead agency. This information is available to the public on request.

- There is no comment period for this DNS.
- This DNS is issued after using the optional DNS process in WAC 197-11-355. There is no further comment period on the DNS.
- This DNS is issued under WAC 197-11-340(2); the lead agency will not act on this proposal for 54 days from the date below. Comments must be submitted by August 31, 2015.

Responsible official: Robert W. Warren

Position/title: Section Manager, Toxics Cleanup Program, Northwest Regional Office Phone: 425-649-7054

Address: Washington State Dept. of Ecology, 3190 160th Avenue SE, Bellevue, Washington 98008

Date: 7/6/15 Signature Louise Bandy for Robert W. Warren

(OPTIONAL)

- You may appeal this determination to (name) _____
at (location) _____
no later than (date) _____
by (method)

You should be prepared to make specific factual objections.
Contact _____ to read or ask about the procedures for SEPA appeals.

- There is no agency appeal.

UPDATED 2014

Purpose of checklist:

Governmental agencies use this checklist to help determine whether the environmental impacts of your proposal are significant. This information is also helpful to determine if available avoidance, minimization or compensatory mitigation measures will address the probable significant impacts or if an environmental impact statement will be prepared to further analyze the proposal.

Instructions for applicants:

This environmental checklist asks you to describe some basic information about your proposal. Please answer each question accurately and carefully, to the best of your knowledge. You may need to consult with an agency specialist or private consultant for some questions. You may use "not applicable" or "does not apply" only when you can explain why it does not apply and not when the answer is unknown. You may also attach or incorporate by reference additional studies reports. Complete and accurate answers to these questions often avoid delays with the SEPA process as well as later in the decision-making process.

The checklist questions apply to all parts of your proposal, even if you plan to do them over a period of time or on different parcels of land. Attach any additional information that will help describe your proposal or its environmental effects. The agency to which you submit this checklist may ask you to explain your answers or provide additional information reasonably related to determining if there may be significant adverse impact.

Instructions for Lead Agencies:

Please adjust the format of this template as needed. Additional information may be necessary to evaluate the existing environment, all interrelated aspects of the proposal and an analysis of adverse impacts. The checklist is considered the first but not necessarily the only source of information needed to make an adequate threshold determination. Once a threshold determination is made, the lead agency is responsible for the completeness and accuracy of the checklist and other supporting documents.

Use of checklist for non-project proposals:

For non-project proposals (such as ordinances, regulations, plans and programs), complete the applicable parts of sections A and B plus the [SUPPLEMENTAL SHEET FOR NON-PROJECT ACTIONS \(part D\)](#). Please completely answer all questions that apply and note that the words "project," "applicant," and "property or site" should be read as "proposal," "proponent," and "affected geographic area," respectively. The lead agency may exclude (for non-projects) questions in Part B - Environmental Elements –that do not contribute meaningfully to the analysis of the proposal.

A. Background

1. Name of proposed project, if applicable:

Interim Action at the Lower Yard of Unocal Edmonds Bulk Fuel Terminal

2. Name of applicant:

Chevron Environmental Management Company (Chevron) for Union Oil Company of California (Unocal)

3. Address and phone number of applicant and contact person:

Ms. Kim Jolitz
Chevron Environmental Management Company
6101 Bollinger Canyon Road San Ramon, CA 94583
Tel (925) 790-3946
E-mail: kjolitz@chevron.com

4. Date checklist prepared:

May 29, 2015

5. Agency requesting checklist:

Washington State Department of Ecology (Ecology)

6. Proposed timing or schedule (including phasing, if applicable):

The interim action in the Lower Yard of the former bulk fuel terminal will consist of soil excavation, removal of contaminated media (light non-aqueous phase liquid (LNAPL), soil and groundwater) from open excavations, and the installation of a dual phase extraction (DPE) system in the vicinity of a Washington State Department of Transportation storm drain. The remedial implementation is scheduled to begin in Summer 2015.

7. Do you have any plans for future additions, expansion, or further activity related to or connected with this proposal? If yes, explain.

No. The property is in escrow for sale to the Washington State Department of Transportation (WSDOT).

The DPE system is to be transferred to WSDOT once the requirements of the purchase and sale agreement (PSA) are met.

Future property uses are expected to be consistent with those allowed by the current zoning code of MP2, which allows for commercial, multifamily residential (above the ground floor) and multimodal transportation center uses. Washington State Ferries considers this location as a potential site for relocation of the Edmonds Ferry Terminal as

part of the Edmonds Crossing Project. The Federal Transit Administration, the Federal Highways Administration, and the Washington State Department of Transportation completed a National Environmental Policy Act (NEPA) Environmental Impact Statement and a Record of Decision (ROD) for the Edmonds Crossing Project in 2004 to relocate the Edmonds Ferry Terminal to the Unocal Edmonds Lower Yard.

8. List any environmental information you know about that has been prepared, or will be prepared, directly related to this proposal.

The following list are the most applicable environmental reports that have been prepared regarding this proposal. These reports are available at Ecology's Northwest Regional Office Central Records unless otherwise noted. Reports marked with † are available online at Ecology's Unocal Edmonds web site:

<https://fortress.wa.gov/ecy/gsp/Sitepage.aspx?csid=5180>, click on View Electronic Documents in the sidebar.

- †Ecology, 2014. Review of Proposed Addendum to the Draft Feasibility Study Report, Former Unocal Edmonds Bulk Fuel Terminal, dated August 11, 2014.
- †ARCADIS U.S. Inc., 2014. Draft FS Addendum, Former Unocal Edmonds Bulk Fuel Terminal, 11720 Unoco Road, Edmonds, Washington. August 11, 2014.
- †ARCADIS U.S. Inc., 2014. Draft Feasibility Study Report, Former Unocal Edmonds Bulk Fuel Terminal, 11720 Unoco Road, Edmonds, Washington. January 30, 2014.
- †ARCADIS U.S. Inc., 2013. Cleanup Levels and Remediation Levels Report. Former Unocal Edmonds Bulk Fuel Terminal, 11720 Unoco Road, Edmonds, Washington. September 17, 2013. Available online at Ecology's Unocal Edmonds web site.
- †ARCADIS U.S. Inc., 2013. Final Conceptual Site Model. Former Unocal Edmonds Bulk Fuel Terminal, 11720 Unoco Road, Edmonds, Washington. May 15, 2013.
- ARCADIS U.S. Inc., 2011. Final 2011 Site Investigation Completion Report. Former Unocal Edmonds Bulk Fuel Terminal, 11720 Unoco Road, Edmonds, Washington. May 11, 2011.
- ARCADIS U.S. Inc., 2010. Final Phase II Remedial Implementation As-Built Report. Former Unocal Edmonds Bulk Fuel Terminal, 11720 Unoco Road, Edmonds, Washington. January 18, 2010.
- ARCADIS U.S. Inc., 2009. Final Phase I Remedial Implementation As-Built Report. Former Unocal Edmonds Bulk Fuel Terminal, 11720 Unoco Road, Edmonds, Washington. July 31, 2009.
- CH2MHill, 2004. Final Environmental Impact Statement and Final Section 4(f) Evaluation. November 2004. Table of Contents available online at:

- Maul Foster & Alongi, 2003. Supplemental Remedial Investigation Report, Unocal Edmonds Terminal, Edmonds. Washington. April 8, 2003.
- Maul Foster & Alongi, 2001. Remedial Investigation Report, Unocal Edmonds Bulk Fuel Terminal, Edmonds, Washington. June 2001.

9. Do you know whether applications are pending for governmental approvals of other proposals directly affecting the property covered by your proposal? If yes, explain.

None known.

10. List any government approvals or permits that will be needed for your proposal, if known.

Federal:

- Joint Aquatic Resource Permit Application (JARPA)

State:

- Hydraulic Project Approval (HPA)
- National Pollution Discharge Elimination System (NPDES) Permit

Local:

- Puget Sound Clean Air Agency (PSCAA)

11. Give brief, complete description of your proposal, including the proposed uses and the size of the project and site. There are several questions later in this checklist that ask you to describe certain aspects of your proposal. You do not need to repeat those answers on this page. (Lead agencies may modify this form to include additional specific information on project description.)

The project Site includes the Upper Yard, the Lower Yard, and the Fish Hatchery. The Lower Yard is where the proposed project will be located and hence is the focus of this SEPA checklist. The Lower Yard includes a total area of 22 acres. The specific objective of this Interim Action is to remediate soil and groundwater in the Lower Yard in two discrete areas with remaining impacts: Detention Basin 2 (DB-2) and the WSDOT stormwater line. This will be achieved by excavation in the area of DB-2 and installation of a DPE system near a portion of the WSDOT stormwater line.

1. Excavation in areas of DB-2 will:

- Remove recoverable LNAPL, and
- Remove soil and groundwater with petroleum hydrocarbon impacts above remediation levels (RELS) and clean up levels (CULs).

Prior to the excavation, the stormwater collection system will be rerouted from the nearest catch basin around the proposed excavation area and connected directly into Detention Basin 1 (DB-1). Water will be pumped from the catch basin through above ground hoses/ pipes under a new NPDES permit. Existing piping will be initially capped and then removed during excavation activities. After completion of DB-2 excavation, above grade piping will be installed in DB-1 for discharge through outfall #002, and stormwater catch basins will be permanently routed to discharge to DB-1. This work is anticipated to take one construction season.

2. Installation and operation of a DPE system:

A soil and groundwater treatment system using DPE will be installed to address petroleum hydrocarbon impacts remaining near a portion of the WSDOT SR 104 stormwater line area. DPE is a remedial technology that extracts water and vapor using pumping wells. DPE relies on mass transfer and subsequent extraction to reduce the mass of residual LNAPL in vadose and smear zone soils in the subsurface. The DPE system will remediate petroleum hydrocarbon soil impacts surrounding a portion of the WSDOT stormwater line and act as a groundwater extraction system. DPE system installation will occur in one construction season. The system is anticipated to operate for several years to achieve cleanup.

12. Location of the proposal. Give sufficient information for a person to understand the precise location of your proposed project, including a street address, if any, and section, township, and range, if known. If a proposal would occur over a range of area, provide the range or boundaries of the site(s). Provide a legal description, site plan, vicinity map, and topographic map, if reasonably available. While you should submit any plans required by the agency, you are not required to duplicate maps or detailed plans submitted with any permit applications related to this checklist.

The Unocal Edmonds Bulk Fuel Terminal is located at 11720 Unocol Road in Edmonds, Washington (Snohomish County). The Terminal is in Section 23 and the northwest quarter of the northeast quarter of Section 26 in Township 27 North, Range 3 East, Willamette Meridian. The Lower Yard of the Terminal is approximately 22 acres in area. A Site vicinity map and Lower Yard Site map can be found as figures Figures 1-1 and 2-1 of the Interim Action Work Plan (IAWP).

B. Environmental Elements

1. Earth

a. General description of the site (BOLD):

Flat, rolling, hilly, steep slopes, mountainous, other _____

b. What is the steepest slope on the site (approximate percent slope)?

The Lower Yard is essentially flat. There are sloped banks along east, northeast, north, and northwest boundaries of the Lower Yard that run down to Willow Creek (up to approximately 35% slope).

c. What general types of soils are found on the site (for example, clay, sand, gravel, peat, muck)? If you know the classification of agricultural soils, specify them and note any agricultural land of long-term commercial significance and whether the proposal results in removing any of these soils.

The Lower Yard is underlain by fill and alluvium:

Fill. The uppermost unit consists of fill material (Placed in 1929 during Lower Yard Facility development and in 2007/2008 excavations) that occurs throughout the entire Lower Yard, and generally varies in thickness from approximately 1 to 15 feet. The 1929 Backfill consists of silty sands with gravel and sandy silts with gravel. The 2007-2008 interim action excavations were backfilled to 6 to 12 inches above the observed groundwater table in the open excavations with poorly graded coarse gravels ($\frac{3}{8}$ to 1 inch) and little to no fines. Backfill material above the coarse gravel to ground surface was a mixture of very fine to medium sand, trace silt, and fine to medium gravel materials.

Alluvium. Native soil underlies the fill throughout the Lower Yard. The native soil is present from the base of the fill to the maximum explored depth of 41.8 feet bgs. Native soil consists of Marsh Deposits, Beach Deposits, and Whidbey formation. *Marsh Deposits* are found in many areas of the Lower Yard, beneath the 1929 fill unit. This layer is interpreted to be representative of the former marsh horizon beneath the Lower Yard. *Beach Deposits* are found below the 1929 fill unit and marsh deposits, a poorly graded sand formation of very fine to medium sand with fine gravel containing organic material such as driftwood and seashells. *Whidbey Formation* is a poorly graded sand layer consisting of very fine to medium sand with fine gravel and is distinct from the overlying materials in the Lower Yard. It is present to the maximum depth explored by Unocal (41.8 feet bgs).

d. Are there surface indications or history of unstable soils in the immediate vicinity? If so, describe.

There are no unstable soils in the vicinity of planned excavation and DPE system.

e. Describe the purpose, type, total area, and approximate quantities and total affected area of any filling, excavation, and grading proposed. Indicate source of fill.

Excavation to remove petroleum hydrocarbon-impacted soil will typically extend to a depth of approximately 10-12 feet bgs. The excavation area was delineated in the 2011 soil assessment (ARCADIS U.S. Inc., 2011) and includes impacted soil in the vicinity of DB-2 and an adjacent monitoring well MW-510. The excavation boundary is limited to the following areas with a total area estimated as 0.696 acres.

- To the northwest by the berm separating DB-2 from Willow Creek and extending approximately 200 feet to the southeast to the point where clean soil was observed during the 2011 soil assessment.
- To the northeast by the berm separating DB-1 and DB-2 and extending approximately 100 feet to the southwest to the edge of previous excavation work.

To safely remove petroleum hydrocarbon impacted soil in vicinity of DB-2 and to allow adequate room to maintain excavation sidewall stability, a temporary earthen berm will be offset from the existing DB-1/DB-2 berm as shown on Figure 8-1 in the IAWP. Water will be removed from the northeast portion of DB-1 and the proposed area of excavation.

The total estimated amount of excavated contaminated soil is expected to be approximately 6,900 cubic yards. These areas will be backfilled to match the original grade. Excavated soil that contains Total Petroleum Hydrocarbon (TPH) concentrations greater than the MTCA Method A cleanup level will be hauled off-Site for treatment and/or disposal. Future imported fill is anticipated to be obtained from an Ecology approved supplier, and will be certified as clean. The planned areas of soil excavation are shown on the Figure 8-1 in the IWAP.

f. Could erosion occur as a result of clearing, construction, or use? If so, generally describe.

Potential erosion could occur during excavation if the work is conducted during rainy periods. Erosion will be controlled per an erosion control and sedimentation control plan.

g. About what percent of the site will be covered with impervious surfaces after project construction (for example, asphalt or buildings)?

No impervious surface will be added as part of the interim action.

h. Proposed measures to reduce or control erosion, or other impacts to the earth, if any:

Prepare and implement an erosion control and sedimentation plan. Measures will include use of filter fabric fences, straw bales barriers, and storm drain inlet protection.

2. Air

- a. **What types of emissions to the air would result from the proposal during construction, operation, and maintenance when the project is completed? If any, generally describe and give approximate quantities if known.**

During the excavation activities, dust, truck emissions, and petroleum hydrocarbon odors could be emitted to the air. There would be no anticipated emissions after excavation activities are completed. A PSCAA permit would be obtained prior to discharging any air emissions from the DPE system.

- b. **Are there any off-site sources of emissions or odor that may affect your proposal? If so, generally describe.**

No.

- c. **Proposed measures to reduce or control emissions or other impacts to air, if any:**

Dust will be controlled by water spray. No visible dust will be allowed.

The proposed DPE system will be equipped with a catalytic oxidizer (CATOX) for vapor treatment and to reduce air emissions prior to discharge to atmosphere. Sampling will be done as specified in a Puget Sound Clean Air Agency permit to document compliance with permit requirements.

3. Water

- a. **Surface Water:**

- 1) **Is there any surface water body on or in the immediate vicinity of the site (including year-round and seasonal streams, saltwater, lakes, ponds, wetlands)? If yes, describe type and provide names. If appropriate, state what stream or river it flows into.**

Willow Creek runs along the east, northeast, north, and northwest boundaries of the Lower Yard, and discharges into the Puget Sound. Edmonds Marsh is located to the northeast of the Lower Yard, and is connected to Willow Creek. Willow Creek runs in a man-made drainage ditch and an underground piped culvert between Edmonds Marsh and Puget Sound.

- 2) **Will the project require any work over, in, or adjacent to (within 200 feet) the described waters? If yes, please describe and attach available plans.**

The berm separating DB-2 from Willow Creek will be excavated. To protect Willow Creek, two coffer dams will be placed in Willow Creek approximately 200 feet apart along the northwest excavation boundary. Water from Willow Creek will be diverted

around the coffer dams using pumps. Following excavation, the coffer dams will be removed and Willow Creek will be restored to its original stream bed.

Impacted soil in the area of DB-2 will be excavated and recoverable LNAPL will be removed using vacuum dewatering trucks. Waste material will be direct loaded into truck and trailers for off-Site disposal, or stockpiled in a central location for loading into truck and trailers for transportation to an appropriate waste disposal facility. Following completion of the DB-2 excavation, the temporary berm will be removed and DB-1 will be returned to its original boundary. As part of Site restoration, DB-2 will be removed from the Site. The proposed excavation boundaries, including the temporary berm location, are shown on Figure 8-1 of the IAWP.

Excavation to remove petroleum hydrocarbon-impacted soil will be conducted within 200 feet of Willow Creek. The planned excavation area is shown on Figure 8-1 of the IAWP. The extracted groundwater from the excavation in DB-2 will be pumped into an on-Site groundwater treatment system prior to discharge to Willow Creek for subsequent discharge pursuant to the conditions of an NPDES Individual Stormwater Permit.

After petroleum product and groundwater removal, the excavations will be backfilled with clean imported material and the excavated soil that contains petroleum hydrocarbon concentrations below the remediation levels for TPH and benzene and the CUL for total carcinogenic polyaromatic hydrocarbons (cPAHs). The excavated soil will only be used as backfill material at depths above the high seasonal groundwater table.

3) Estimate the amount of fill and dredge material that would be placed in or removed from surface water or wetlands and indicate the area of the site that would be affected. Indicate the source of fill material.

Certified clean fill material (source to be determined) will be placed along both (northeast and northwest) ends of the excavation border within Willow Creek to install two temporary coffer dams. Each coffer dam will be composed of 188 cubic yards (CY) of fill material (376 CY total) and will be removed after excavation. Clean fill will also be placed in a temporary berm separating the northern portion of DB-1 to allow for dewatering and excavation of DB-2. The berm will be approximately 450 cubic yards and will be removed following excavation.

4) Will the proposal require surface water withdrawals or diversions? Give general description, purpose, and approximate quantities if known.

To minimize the volume of water to be diverted around the remediation area, DB-2 Excavation work will be conducted during a dry period of the year (Summer), when less stormwater is expected. Furthermore, coffer dams will be installed at low tide. Prior to conducting the work, coffer dams will be installed at the southwest (downstream) and northeast (upstream) ends of the excavation area. The area of the Willow Creek between the coffer dams will be dewatered by pumping the water into an on-Site treatment system prior to discharge to the Willow Creek at a location a location

downstream of the remediation area. The water treatment and subsequent discharge will be pursuant to the conditions of a NPDES Individual Stormwater Permit. The dewatering will be conducted throughout the excavation/backfilling, as necessary. During dewatering, a qualified wildlife biologist will remove any fish and marine organisms from the dammed area. The water in the Willow Creek that collects along the outside of each dam (depending upon the flow direction in the Willow Creek) will be pumped around the remediation area.

5) Does the proposal lie within a 100-year floodplain? If so, note location on the site plan.

A small portion of the Site on the eastern boundary (immediate southeast of DB-1 along Willow Creek boundary) lies within 100-year floodplain. See Figure H-1 attached.

6) Does the proposal involve any discharges of waste materials to surface waters? If so, describe the type of waste and anticipated volume of discharge.

No waste materials will be discharged to surface waters. The groundwater that is extracted from the excavations and the water generated from the DPE system operation will be treated and discharged via DB-1 in accordance with NPDES stormwater permit. The system will be operated and the effluent sampled in accordance with an NPDES permit.

The estimated flow for dewatering the proposed excavation is 15 gallons per minute (gpm) and is based on the volume of water pumped and discharged during the 2007/2008 interim action. The estimated flow for the water generated from the DPE system is based on the long-term, average groundwater extraction rate required to lower the water table within the target treatment zone, is estimated at 21 gpm using the MODFLOW model for the Site. The overall system effluent discharge may be higher based on DPE system pilot test results. The system will be designed to treat a maximum discharge rate of 80 gpm.

b. Ground Water:

1) Will groundwater be withdrawn from a well for drinking water or other purposes? If so, give a general description of the well, proposed uses and approximate quantities withdrawn from the well. Will water be discharged to groundwater? Give general description, purpose, and approximate quantities if known.

No.

2) Describe waste material that will be discharged into the ground from septic tanks or other sources, if any (for example: Domestic sewage; industrial, containing the following chemicals. . . ; agricultural; etc.). Describe the general size of the system, the number of such systems, the number of houses to be served (if applicable), or the number of animals or humans the system(s) are expected to serve.

None.

c. Water runoff (including stormwater):

- 1) Describe the source of runoff (including storm water) and method of collection and disposal, if any (include quantities, if known). Where will this water flow? Will this water flow into other waters? If so, describe.**

Storm water will be collected within the stormwater collection system that consists of two legs of piping. During excavation, a portion of the existing northwestern stormwater collection line will be removed. A sump pump with float will be installed in the collection drain nearest the excavation boundary on the northwestern line. The pump will connect to above ground hose and discharge through above grade hose to DB-1. Following excavation new piping will connect both storm water lines and extend the outfall of each line to DB-1. The final storm water collection system will consist of 12 catch basins. DB-1 serves as a stormwater collection area from which Lower Yard stormwater is discharged into Willow Creek via Outfall #002 under Industrial Stormwater General Permit No. SO3-002953C. DB-1 forms a depression approximately 6 feet deep and is an unlined pond. Water from DB-1 will be pumped via two submerged pumps and a piping system connecting to outfall #002. Outfall #002 discharges to Willow Creek. After excavation is complete DB-2 will be filled and the stormwater system will drain directly to DB-1.

Willow Creek runs along the east, northeast, north, and northwest boundaries of the Lower Yard. Willow Creek is approximately 10 feet wide and is underlain by silt and sand material. The creek banks on the property boundary are sloped (up to approximately 35%) and vegetated with native and non-native vegetation. Water depths in Willow Creek vary from 0 to 4 feet deep, depending on season and tidal cycles. Willow Creek flows into a tidal basin. The flow is conveyed from the tidal basin to Puget Sound in an underground pipe.

A WSDOT stormwater line runs across the southern portion of the Lower Yard, along lower Unoco Road, and out to Puget Sound (Figure 2-1 of the IAWP).

- 2) Could waste materials enter ground or surface waters? If so, generally describe.**

No. The water generated from construction and from the groundwater treatment system will be treated and sampled in accordance with the NPDES permit requirements to confirm that the ground and surface water will not be adversely impacted.

- 3) Does the proposal alter or otherwise affect drainage patterns in the vicinity of the site? If so, describe.**

Willow Creek will be diverted during excavation of DB-2. Cofferdams will be placed blocking the creek flow at the northern and southern intersections of DB-2 excavation boundary and willow creek. Pumps will divert flow around the cofferdams to maintain the natural flow rates and drainage patterns in the vicinity of the Site. The cofferdams will be removed and the creek restored when the project is completed.

4) Proposed measures to reduce or control surface, ground, and runoff water, and drainage pattern impacts, if any:

The existing stormwater system collects surface-water runoff and conveys collected stormwater directly into DB-2 via gravity flow. DB-2 serves as a stormwater collection area from which Lower Yard stormwater is discharged into Willow Creek via Outfall #002 under Industrial Stormwater General Permit No. SO3-002953C. DB-1 acts as a retention pond for overflow from DB-2 during storm events.

Existing piping used to collect on-Site stormwater intersects the excavation area and discharges into DB-2. Prior to excavation, the stormwater collection system will be rerouted around the proposed excavation area and discharged directly into DB-1 through above ground hoses under the new NPDES permit. Existing piping will be initially capped and then removed during excavation activities. After completion of DB-2 excavation, above grade piping will be installed in DB-1 for discharge through outfall #002. Stormwater catch basins will be permanently routed to DB-1 upon excavation completion.

The proposed excavation will intersect a section of Willow Creek. In order to maintain the natural flow and drainage pattern, above grade piping and pumps will divert water around the coffer dams.

4. Plants

a. Check the types of vegetation found on the site:

- deciduous tree: alder, maple, aspen, other
- evergreen tree: fir, cedar, pine, other
- shrubs
- grass
- pasture
- crop or grain
- orchards, vineyards or other permanent crops.
- wet soil plants: cattail, buttercup, bulrush, skunk cabbage, other
- water plants: water lily, eelgrass, milfoil, other
- other types of vegetation

b. What kind and amount of vegetation will be removed or altered?

Nothing other than routine weed abatement work.

c. List threatened and endangered species known to be on or near the site.

None known.

d. Proposed landscaping, use of native plants, or other measures to preserve or enhance vegetation on the site, if any:

Native species will be planted along the banks of Willow Creek to re-establish a riparian wetland community to restore conditions and increase ecosystem function in Willow Creek.

e. List all noxious weeds and invasive species known to be on or near the site.

None. Occasionally, gorse (*Ulex Europeus*) growth encountered in the Lower Yard. Gorse is a weed that displaces native plants. Gorse removal activities are conducted at the Site on an as needed basis. The recent most gorse removal activities were conducted in the Lower Yard in December 2014.

5. Animals

a. List any birds and other animals which have been observed on or near the site or are known to be on or near the site. Examples include:

Birds: Historically heron and bald eagles have been observed near the Site.
Mammals: Historically Coyote have been seen at the Site occasionally.
Fish: Pacific salmon, and groundfish have been observed in Willow Creek.

b. List any threatened and endangered species known to be on or near the site.

None.

c. Is the site part of a migration route? If so, explain.

No.

d. Proposed measures to preserve or enhance wildlife, if any:

None.

e. List any invasive animal species known to be on or near the site.

None.

6. Energy and natural resources

a. What kinds of energy (electric, natural gas, oil, wood stove, solar) will be used to meet the completed project's energy needs? Describe whether it will be used for heating, manufacturing, etc.

Electricity will be used to run the DPE system.

- b. Would your project affect the potential use of solar energy by adjacent properties? If so, generally describe.**

No.

- c. What kinds of energy conservation features are included in the plans of this proposal? List other proposed measures to reduce or control energy impacts, if any:**

None.

7. Environmental health

- a. Are there any environmental health hazards, including exposure to toxic chemicals, risk of fire and explosion, spill, or hazardous waste that could occur as a result of this proposal? If so, describe.**

Risk of exposure to construction workers (dermal contact, ingestion, inhalation) by dust, petroleum hydrocarbon vapors, petroleum product, or petroleum hydrocarbon-contaminated soil/groundwater. Risks to be controlled by Site specific health and safety plan, including dust control, air monitoring, and protective clothing.

- b. Describe any known or possible contamination at the site from present or past uses.**

From 1954 to 1990, several documented spills occurred at the terminal, totaling approximately 155,000 gallons. Spilled quantities ranged from a few gallons to 80,000 gallons and involved fuel oils, heavy oils, gasoline, off-specification asphalt, and diesel products. Periodic product releases (approximately 0.2 gallon to 2 gallons) reportedly occurred from valves, flanges, and pumps in the Upper and Lower Yards throughout the terminal history. Records and documentation of these smaller releases are not available. The Site has been the focus of several significant phases of remedial activity and as a result, much of the impacts from historical use no longer remain.

- c. Describe existing hazardous chemicals/conditions that might affect project development and design. This includes underground hazardous liquid and gas transmission pipelines located within the project area and in the vicinity.**

The chemicals expected to be present in the water generated from the excavation and DPE treatment system include TPH, cPAHs, and benzene. These chemicals are the focus of the project development and design.

- d. Describe any toxic or hazardous chemicals that might be stored, used, or produced during the project's development or construction, or at any time during the operating life of the project.**

No significant quantities of toxic or hazardous chemicals are planned for use, storage or production.

e. Describe special emergency services that might be required.

Routine medical facility services as necessary in case of worker exposures noted above.

f. Proposed measures to reduce or control environmental health hazards, if any:

Workers will have received Hazardous Waste Operations and Emergency Response training. Workers will follow a Site-specific health and safety plan, including use of protective clothing as required. Air monitoring with field instruments and visual monitoring of fugitive dust will be performed during the interim action.

8. Noise

a. What types of noise exist in the area which may affect your project (for example: traffic, equipment, operation, other)?

There is little noise in the area. The most significant noise in the area is occasional blasts from the horn of ferries leaving the Edmonds ferry terminal and from passing trains. Noise will not affect the project.

b. What types and levels of noise would be created by or associated with the project on a short-term or a long-term basis (for example: traffic, construction, operation, other)? Indicate what hours noise would come from the site.

There will be short-term noise associated with heavy equipment operation, disposal truck traffic, and construction activities for the two weeks of active construction duration as well as noise from the DPE system. The construction activities will be limited to business hours of operation. The most significant short-term noise is likely to be backup horns on heavy equipment and trucks.

The DPE system will operate 24 hours a day, but the noise produced will be abated using noise attenuation devices and will not exceed the city of Edmonds noise ordinance.

c. Proposed measures to reduce or control noise impacts, if any:

Excavation and construction activities will be limited to during daytime/business hours. Noise from backup horns cannot be abated.

The DPE system will be equipped with sound attenuating insulation and engineered acoustic dampening devices to reduce noise levels originating from the system.

9. Land and shoreline use

a. What is the current use of the site and adjacent properties? Will the proposal affect current land uses on nearby or adjacent properties? If so, describe.

The Site is a former bulk fuel storage/distribution terminal. The terminal has been removed and the Lower yard is currently vacant with the exception of a temporary storage shed. The properties to the north/northeast is open space (Edmonds Marsh); to the southeast is Deer Creek Salmon Hatchery; to the south is a condominium development built after 2003; and to the west/northwest are the Burlington Northern and Santa Fe (BNSF) railroad tracks and the Port of Edmonds marina. The project is not anticipated to significantly affect nearby land uses.

- b. Has the project site been used as working farmlands or working forest lands? If so, describe. How much agricultural or forest land of long-term commercial significance will be converted to other uses as a result of the proposal, if any? If resource lands have not been designated, how many acres in farmland or forest land tax status will be converted to nonfarm or nonforest use?**

No.

- c. Will the proposal affect or be affected by surrounding working farm or forest land normal business operations, such as oversized equipment access, the application of pesticides, tilling, and harvesting? If so, how:**

No.

- d. Describe any structures on the site.**

A temporary storage shed exists on-Site.

- e. Will any structures be demolished? If so, what?**

None. Upon project completion the temporary storage shed will be removed.

- f. What is the current zoning classification of the site?**

The Lower Yard is zoned MP2 (Master Plan Hillside Mixed Use). MP2 allowed uses include multi-family residential, office, hotels/motels, restaurants, excluding drive-in business, local public facilities, retail uses excluding activity that relies on outdoor display of merchandise, conference/performance arts center, day care, parks and open spaces, and multimodal transportation center. Residential use is prohibited on the ground floor of any building.

- g. What is the current comprehensive plan designation of the site?**

The Draft 2015 City of Edmonds Comprehensive Plan, dated July, 2015, designates the Site as Master Plan Development.

- h. If applicable, what is the current shoreline master program designation of the site?**

No designation.

- i. Has any part of the site been classified as a critical area by the city or county? If so, specify.**

DB-1 was characterized in a 1995 study as a disturbed, emergent wetland. The eastern edge of the Lower Yard (along Willow Creek and part of the Edmonds Marsh) was characterized as a wetland. Portions of the Upper Yard were characterized as steep slope.

- j. Approximately how many people would reside or work in the completed project?**

None.

- k. Approximately how many people would the completed project displace?**

None.

- l. Proposed measures to avoid or reduce displacement impacts, if any:**

Does not apply.

- m. Proposed measures to ensure the proposal is compatible with existing and projected land uses and plans, if any:**

After excavation of contaminated soil and installation of the DPE system, the only apparent above-ground new structure will be the addition of the DPE treatment system building (See 11a). There will be little change from current Site conditions. Underground and above-ground systems will be laid out to be compatible with reasonably anticipated future land use. Their location can be adjusted if necessary.

- n. Proposed measures to ensure the proposal is compatible with nearby agricultural and forest lands of long-term commercial significance, if any:**

Does not apply.

10. Housing

- a. Approximately how many units would be provided, if any? Indicate whether high, middle, or low-income housing.**

None.

- b. Approximately how many units, if any, would be eliminated? Indicate whether high, middle, or low-income housing.**

Does not apply.

c. Proposed measures to reduce or control housing impacts, if any:

Does not apply.

11. Aesthetics

a. What is the tallest height of any proposed structure(s), not including antennas; what is the principal exterior building material(s) proposed?

A structure will house the components of the DPE remediation system. The maximum height of the structure will be approximately 15 feet constructed of metal and wood. The building exterior will be constructed to meet local building code and will be completed with painted metal siding. The system will discharge treated vapor through a metal effluent stack at a height of 20 feet above ground surface.

b. What views in the immediate vicinity would be altered or obstructed?

None.

c. Proposed measures to reduce or control aesthetic impacts, if any:

Does not apply.

12. Light and glare

a. What type of light or glare will the proposal produce? What time of day would it mainly occur?

None.

b. Could light or glare from the finished project be a safety hazard or interfere with views?

Does not apply.

c. What existing off-site sources of light or glare may affect your proposal?

None.

d. Proposed measures to reduce or control light and glare impacts, if any:

Does not apply.

13. Recreation

a. What designated and informal recreational opportunities are in the immediate vicinity?

None.

- b. Would the proposed project displace any existing recreational uses? If so, describe.**

No.

- c. Proposed measures to reduce or control impacts on recreation, including recreation opportunities to be provided by the project or applicant, if any:**

Does not apply.

14. Historic and cultural preservation

- a. Are there any buildings, structures, or sites, located on or near the site that are over 45 years old listed in or eligible for listing in national, state, or local preservation registers located on or near the site? If so, specifically describe.**

None known.

- b. Are there any landmarks, features, or other evidence of Indian or historic use or occupation? This may include human burials or old cemeteries. Are there any material evidence, artifacts, or areas of cultural importance on or near the site? Please list any professional studies conducted at the site to identify such resources.**

None known.

- c. Describe the methods used to assess the potential impacts to cultural and historic resources on or near the project site. Examples include consultation with tribes and the department of archeology and historic preservation, archaeological surveys, historic maps, GIS data, etc.**

An archeological monitoring was conducted by Northwest Archeological Associates, Inc. during 2008 excavation activities at the Site. Archeological Associates, Inc stated that no significant cultural resources were observed during the monitoring. (ARCADIS, 2010).

- d. Proposed measures to avoid, minimize, or compensate for loss, changes to, and disturbance to resources. Please include plans for the above and any permits that may be required.**

There are no cultural or historic resources present in the Lower Yard.

15. Transportation

- a. Identify public streets and highways serving the site or affected geographic area and describe proposed access to the existing street system. Show on site plans, if any.**

Site is served by State Route 104 and Pine Street.

- b. Is the site or affected geographic area currently served by public transit? If so, generally describe. If not, what is the approximate distance to the nearest transit stop?**

Community Transit Routes 130 and 416, Stops C1168 (SB) and C683 (NB) at 5th Avenue South and Pine, approximately 0.4 miles east.

Edmonds Station, 211 Railroad Avenue, Edmonds, WA. Amtrak and Sounder trains. Located approximately 0.4 miles northeast of the Site.

Edmonds-Kingston Ferry Terminal is located approximately 0.5 miles northeast of the Site.

- c. How many additional parking spaces would the completed project or non-project proposal have? How many would the project or proposal eliminate?**

Does not apply.

- d. Will the proposal require any new or improvements to existing roads, streets, pedestrian, bicycle or state transportation facilities, not including driveways? If so, generally describe (indicate whether public or private).**

No.

- e. Will the project or proposal use (or occur in the immediate vicinity of) water, rail, or air transportation? If so, generally describe.**

BNSF Railway tracks are located adjacent to the northwest of the Site. The Port of Edmonds Marina is located to the northwest of the Site, beyond the BNSF property. Edmonds Station, with Amtrak and Sounder train service, is located approximately 0.4 miles northeast of the Site. Edmonds-Kingston Ferry Terminal is located approximately 0.5 miles northeast of the Site.

- f. How many vehicular trips per day would be generated by the completed project or proposal? If known, indicate when peak volumes would occur and what percentage of the volume would be trucks (such as commercial and nonpassenger vehicles). What data or transportation models were used to make these estimates?**

None.

- g. Will the proposal interfere with, affect or be affected by the movement of agricultural and forest products on roads or streets in the area? If so, generally describe.**

No.

- h. Proposed measures to reduce or control transportation impacts, if any:**

Does not apply.

16. Public services

- a. **Would the project result in an increased need for public services (for example: fire protection, police protection, public transit, health care, schools, other)? If so, generally describe.**

No.

- b. **Proposed measures to reduce or control direct impacts on public services, if any.**

Does not apply.

17. Utilities

- a. **Circle utilities currently available at the site:**

Electricity, natural gas, water, refuse service, telephone, sanitary sewer, septic system, other _____

Stormwater conveyance system

- b. **Describe the utilities that are proposed for the project, the utility providing the service, and the general construction activities on the site or in the immediate vicinity which might be needed.**

Existing power from Public Utility District of Snohomish County will be upgraded to sustain DPE system operation. This will be achieved by trenching electrical conduit from the existing power drop.

C. Signature

The above answers are true and complete to the best of my knowledge. I understand that the lead agency is relying on them to make its decision.

Signature:  _____

Name of signee: Scott Zorn _____

Position and Agency/Organization: Principal Geologist/ARCADIS _____

Date Submitted: May 29, 2015 _____



Appendix H Figure

CITY: ENV, CA DIV/GROUP: ENVCAD DB: ASR PM: TME TR: LVR: ON=OFF=REF- (FRZ)
 I:\arcad\proj\B0045382\PRESENTATION\FIGURES\B0045382_B02-18A.dwg LAYOUT: H-1 SAVED: 6/23/2015 8:11 AM ACADVER: 18.1 S (LMS TECH) PAGES: 18 PLOTSTYLETABLE: PLTHALF.CTB PLOTTED: 6/23/2015 8:15 AM BY: HUTCHINS-WASS, TABITHA
 XREFS: IMAGES: PROJECTNAME: 45382X02 45382X03

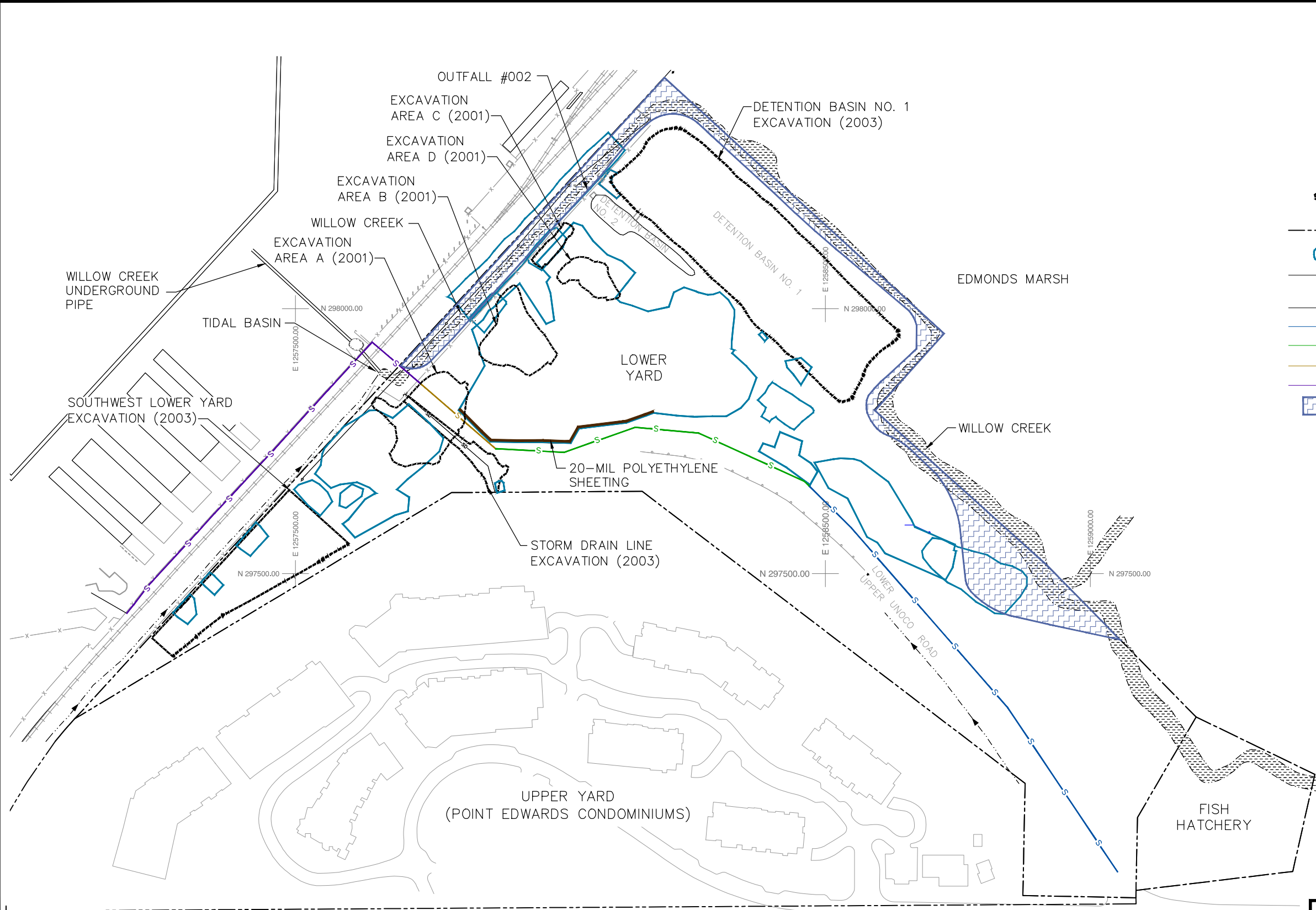

- LEGEND:**
- 2001 AND 2003 SOIL EXCAVATIONS BELOW GROUNDWATER TABLE
 - PROPERTY BOUNDARY
 - 2007/2008 EXCAVATION BOUNDARIES
 - WSDOT STORMWATER LINE (DIAMETER OF STORMWATER LINE INDICATED BY COLOR)
 - POINT EDWARDS STORM DRAIN LINE
 - 48" DIAMETER STORMWATER LINE
 - 54" DIAMETER STORMWATER LINE
 - 60" DIAMETER STORMWATER LINE
 - 72" DIAMETER STORMWATER LINE
 - 100-YEAR FLOODPLAIN APPROXIMATE AREA

- NOTES:**
1. 20-MIL POLYETHYLENE SHEETING INSTALLED UPON COMPLETION OF PHASE I OF THE 2007/2008 EXCAVATION. SHEETING REACHES TO APPROXIMATELY 7.5 FEET ABOVE MEAN SEA LEVEL.
 2. HORIZONTAL DATUM: WASHINGTON STATE COORDINATE SYSTEM NORTH ZONE (NAD 83/98). VERTICAL DATUM: N.A.V.D. 88 UNITS: U.S. SURVEY FEET HORIZONTAL AND VERTICAL CONTROL ESTABLISHED BY GPS VIA VERTICAL REFERENCE STATION NETWORK (VRSN).
 3. SOUTHEAST PORTION OF WSDOT STORMWATER LINE HAS NOT BEEN SURVEYED.
 4. THE LOCATION OF THE CHANGES IN DIAMETER OF THE WSDOT STORMWATER LINE ARE APPROXIMATE.
 5. SOURCE OF 100-YEAR FLOODPLAIN: FEMA (FEDERAL EMERGENCY MANAGEMENT AGENCY) FLOOD MAP SERVICE CENTER 2015.
 6. WILLOW CREEK UNDERGROUND PIPE HAS NOT BEEN SURVEYED.

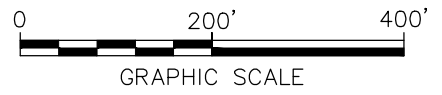

CHEVRON ENVIRONMENTAL MANAGEMENT COMPANY
 FORMER UNOCO BULK FUEL TERMINAL
 EDMONDS, WASHINGTON
SEPA CHECKLIST

SITE LAYOUT

FIGURE
H-1