

**STATE OF WASHINGTON
DEPARTMENT OF ECOLOGY**

In the Matter of Remedial Action by:

USG Interiors, LLC
(Highway 99 Site)

FIRST AMENDMENT TO AGREED ORDER

No. DE 11099

TO: Mr. Preston Wilson, Environmental Manager
USG Interiors, LLC
USG Corporation
550 West Adams St
Chicago, IL 60661

I. BACKGROUND

Agreed Order No. DE 11099 (Order) was entered into by the State of Washington, Department of Ecology (Ecology) and USG Interiors, LLC, on June 24, 2016. The site that is the subject of the Order is USG Interiors (Highway 99), generally located at 7110 Pacific Highway East, Milton, Washington (Facility/Site ID 84531356). USG Interiors, LLC is referred to as “the PLP” in this Order amendment. This amendment to the original Order changes the cleanup action plan (CAP), and modifies the schedule for implementing the CAP. Ecology believes the actions required by this Amendment are in the public interest.

Those provisions of Agreed Order No. DE 11099 that are not specifically changed by this Amendment remain in full force and effect.

II. JURISDICTION

This Amendment to Agreed Order No. DE 11099 is issued pursuant to the authority of the Model Toxics Control Act (MTCA), RCW 70.105D.

II. AMENDMENT

Section VIII, Work to be Performed of the Order is Amended:

The Order, Section VII. (Work to be Performed), is hereby amended with the following requirements:

The CAP is modified to include conducting In-Situ Solidification and Stabilization (ISS) to a greater depth in the Core Remediation Area, targeting all soils in the unsaturated and saturated zone exceeding 250 mg/kg arsenic based on modeling of arsenic concentrations in soils. The planned area of ISS will also capture nearly 85% of soils exceeding 90 mg/kg arsenic, and 35% of soils exceeding 20 mg/kg arsenic. Implementing ISS not only in the vadose soils, but also in the high concentration saturated soils should greatly improve groundwater quality. In addition, all of the soils that exceed 20 mg/kg arsenic on Parcel P429 and the adjacent right-of-way (Parcel P429 Plus) will be excavated and hauled off site to an appropriate disposal facility.

Groundwater monitoring will be used to evaluate the effectiveness of the ISS and excavation on the groundwater contaminant plume. The need for further groundwater treatment methods will be evaluated following 5 years of quarterly groundwater data is obtained to determine the effectiveness of the ISS and excavation. If it is determined that contaminants in the groundwater will not achieve cleanup levels within a reasonable restoration timeframe (20 years), then groundwater treatments will be required. Groundwater treatment will be required until it is demonstrated that contaminant concentrations will achieve cleanup levels within a reasonable restoration timeframe (20 Years).

With this amendment, the operable CAP is the Revised Cleanup Action Plan. Exhibit A is the Revised Cleanup Action Plan and is incorporated as part of this amendment. Exhibit B, Scope of Work and Schedule were revised and are incorporated as part of this amendment.

The undersigned representative of each Party hereby certifies that he or she is fully authorized to enter into this First Amendment of Agreed Order No. DE 11099 and to execute and legally bind such Party to this Amendment.

This First Amendment shall be effective on the date it is signed by the authorized representative of the Department of Ecology.

Effective date of this Order: 7/31/2023

USG INTERIORS, LLC



Ann Franzen
Vice President Manufacturing
Ceilings
USG Corporation
550 West Adams St
Chicago, IL 60661-3676
312-436-4000

STATE OF WASHINGTON
DEPARTMENT OF ECOLOGY



Rebecca S. Lawson, P.E., LHG
Section Manager
Toxics Cleanup Program
Southwest Region Office
360-407-6241

EXHIBIT A

Revised Cleanup Action Plan



Revised Cleanup Action Plan
USG Interiors Highway 99 Site
Milton, Washington

Issued by:
Washington State Department of Ecology
Toxics Cleanup Program
Southwest Regional Office
Olympia, Washington

July 31, 2023

Issued By:

Washington State Department of Ecology
Toxics Cleanup Program
Southwest Regional Office
Olympia, Washington

REVISED CLEANUP ACTION PLAN
USG INTERIORS HIGHWAY 99 SITE
MILTON, WASHINGTON

July 31, 2023

Table of Contents

Executive Summary	ES-1
Background.....	ES-1
Initial Selected Remedial Alternative and Proposed Revised Remedial Alternative of Core Remediation Area	ES-2
Assessment of ISS.....	ES-3
Recommended Revised Remedial Alternative	ES-3
Section 1 Introduction	1-1
1.1 Purpose	1-1
1.2 Regulatory Framework and Background.....	1-1
1.3 Report Organization	1-3
Section 2 Site Description and Remedial Investigation Summary	2-1
2.1 Location and Description	2-1
2.2 Site History.....	2-1
2.3 Physical Setting.....	2-3
2.3.1 Geology.....	2-3
2.3.2 Hydrogeology.....	2-5
2.3.3 Groundwater/Surface Water Interaction.....	2-6
2.4 Nature and Extent of Contamination.....	2-6
2.4.1 Distribution of Arsenic in Soil.....	2-6
2.4.2 Distribution of Arsenic in Groundwater.....	2-7
2.4.3 Distribution of Arsenic in Sediment.....	2-8
2.5 Conceptual Site Model.....	2-8
Section 3 Human Health and Environmental Concerns	3-1
3.1 Media and Contaminant of Concern	3-1
3.2 Cleanup Standards Established for the Site.....	3-1
3.2.1 Cleanup Levels.....	3-1
3.2.2 Remediation Levels.....	3-1
3.2.3 Points of Compliance.....	3-2
3.3 Terrestrial Ecological Evaluation.....	3-3
Section 4 Initial Proposed Cleanup Alternative and Subsequent Pilot Study.....	4-1
4.1 Remedial Goals and Objectives.....	4-1
4.2 Initial Proposed Cleanup Alternative.....	4-2
4.3 Groundwater Pilot Study	4-3
Section 5 Remedial Action Modifications and Justification	5-1
5.1 Summary of Remedial Action Modifications.....	5-1
5.1.1 Core Remediation Area.....	5-1
5.1.2 WSDOT P429 Plus Property.....	5-1
5.2 Geotechnical Field Investigation and Bench Scale Treatability Study Results.....	5-2
5.3 Pilot Study Results.....	5-3
Section 6 Disproportionate Cost Analysis	6-1

6.1 Disproportionate Cost Analysis Methodology	6-1
6.1.1 Protectiveness	6-2
6.1.2 Permanence	6-2
6.1.3 Long-Term Effectiveness	6-2
6.1.4 Management of Short-Term Risks	6-3
6.1.5 Implementability	6-3
6.1.6 Consideration of Public Concerns	6-3
6.1.7 Cost.....	6-4
6.1.8 Criteria Priorities and Score Calculations.....	6-4
6.2 MTCA Disproportionate Cost Analysis.....	6-5
6.2.1 Overall Protectiveness	6-5
6.2.2 Permanence	6-6
6.2.3 Long-Term Effectiveness	6-6
6.2.4 Management of Short-Term Risks	6-6
6.2.5 Technical and Administrative Implementability.....	6-7
6.2.6 Consideration of Public Concerns	6-7
6.2.7 Costs.....	6-7
6.2.8 Results of the DCA.....	6-10
Section 7 Recommended Remedial Alternative	7-1
7.1 ISS Conceptual Design.....	7-1
7.2 P429 Plus Property Conceptual Design.....	7-2
7.3 Applicable Laws and Regulations	7-2
7.3.1 Federal ARARs.....	7-2
7.3.2 Washington State ARARs	7-3
7.4 Remnant Contamination Left Onsite	7-3
7.5 Schedule for Implementation	7-4
7.6 Restoration Time Frame	7-4
7.7 Engineering Design/Plans and Specifications	7-5
7.7.1 Engineering Design Report.....	7-6
7.7.2 Construction Plans and Specifications	7-6
7.8 Compliance Monitoring.....	7-6
7.8.1 Protection Monitoring.....	7-7
7.8.2 Performance Monitoring.....	7-7
7.8.3 Confirmational Monitoring	7-7
7.9 Engineering/Institutional Controls.....	7-8
7.9.1 Engineering Controls	7-8
7.9.2 Institutional Controls.....	7-9
7.10 Operation and Maintenance Expectations.....	7-9
7.11 Public Participation	7-9
Section 8 References	8-1

List of Tables

Table 3-1 Arsenic Cleanup Levels.....	3-1
Table 6-1 Comparison of Soil Volumes and Arsenic Mass Treated for Each Remedial Treatment Alternative.....	6-1
Table 6-2 Implementability Factors to be Considered during Alternative Evaluation.....	6-3
Table 6-3 Summary of Remedial Cost Estimates by Alternative.....	6-9
Table 6-4 Disproportionate Cost Analysis	6-11
Table 7-1 Summary of Proposed ISS Treatment Areas and Volumes ^a	7-1
Table 7-2 Summary of Arsenic Concentrations Treated Using a Cleanup Criteria that Targets >250 mg/kg in the Core Remediation Area.....	7-2

List of Figures

(Figures located at the end of this report)

Figure 1	Vicinity Map
Figure 2	Site Plan and Remedial Investigation Groundwater Sample Location Map
Figure 3	Core Remediation Area and Boring/Monitoring Well Locations
Figure 4	Geologic Cross Section A-A'
Figure 5	Geologic Cross Section B-B'
Figure 6	Groundwater Elevation Contour Map on July 15, 2010
Figure 7	Leapfrog Model Extents of Arsenic in Soil – Plan View
Figure 8	Leapfrog Model Cross Section C-C'
Figure 9	Leapfrog Model Cross Section D-D'
Figure 10	Dissolved Total Arsenic in Groundwater (2010-2012)
Figure 11	Conceptual Site Model
Figure 12	Planned Remedial Excavation WSDOT P429 Plus Property and Creek Bed – Plan View
Figure 13	Planned Remedial Excavation WSDOT P429 Plus Property and Creek Bed – Cross Section Views
Figure 14	Alternative 1: Proposed Treatment Area of Arsenic >20 ppm in Soil - Plan View
Figure 15	Alternative 1: Proposed Treatment Area of Arsenic > 20 ppm in Soil - Cross Section View
Figure 16	Alternative 1: Proposed Treatment Area of Arsenic >20 ppm in Soil – Isometric View
Figure 17	Alternative 2: Proposed Treatment Area of Arsenic >90 ppm in Soil - Plan View
Figure 18	Alternative 2: Proposed Treatment Area of Arsenic > 90 ppm in Soil - Cross Section View
Figure 19	Alternative 2: Proposed Treatment Area of Arsenic > 90 ppm in Soil – Isometric View
Figure 20	Alternative 3: Proposed Treatment Area of Arsenic >250 ppm in Soil - Plan View
Figure 21	Alternative 3: Proposed Treatment Area of Arsenic > 250 ppm in Soil - Cross Section View
Figure 22	Alternative 3: Proposed Treatment Area of Arsenic > 250 ppm in Soil – Isometric View
Figure 23	Alternative 4: Proposed Treatment Area of Arsenic >500 ppm in Soil - Plan View
Figure 24	Alternative 4: Proposed Treatment Area of Arsenic > 500 ppm in Soil - Cross Section View
Figure 25	Alternative 4: Proposed Treatment Area of Arsenic > 500 ppm in Soil – Isometric View

Appendices

- Appendix A Interim Action Work Plan, USG Highway 99 Site Contaminated Creek Sediment Removal and Parcel P429 Plus Soil Excavation
- Appendix B Remedial Alternative Cost Estimates

Acronyms

µg/L	micrograms per liter
ARARs	applicable or relevant and appropriate requirements
bgs	below ground surface
CDM Smith	CDM Smith Inc.
CDR	Conceptual Design Report
CMP	Compliance Monitoring Plan
CSM	Conceptual Site Model
cy	cubic yards
DCA	Disproportionate Cost Analysis
CAP	Cleanup Action Plan
Ecology	Washington State Department of Ecology
EDR	Engineering Design Report
EL	Elevation
EP	Extraction Procedure
EPA	Environmental Protection Agency
FS	Feasibility Study
FSH	ferrous sulfate heptahydrate
ft	Feet
I-5	Interstate 5
IAWP	Interim Action Work Plan
ISCO	In situ chemical oxidation
ISS	In situ solidification and stabilization
Leapfrog	Leapfrog Works®
mg/kg	milligrams per kilogram
mg/L	milligrams per liter

Acronyms

MNA	monitored natural attenuation
MSL	mean sea level
MTCA	Model Toxics Control Act
MW	monitoring well
RAO	Remedial Action Objectives
RCAP	Revised Cleanup Action Plan
RCW	Revised Code of Washington
RI	Remedial Investigation
ROI	Radius of Influence
SAP	Sampling and Analysis Plan
SDL	semi-dynamic leach
S/S	solidification/stabilization
TEE	Terrestrial Ecological Evaluation
UCS	unconfined compression strength
USG	USG Corporation
USGI	USG Interiors LLC
WAC	Washington Administrative Code
WSDOT	Washington State Department of Transportation
XRF	X-ray fluorescence device

Executive Summary

This document presents a Revised Cleanup Action Plan (RCAP) for USG Corporation's (USG) USG Interiors LLC (USGI) Highway 99 site (Cleanup Site ID 3618) generally located at 7110 Pacific Highway East (aka Highway 99), Milton, Washington (site or Highway 99 site). This RCAP revises the Cleanup Action Plan (CAP) for the Highway 99 site dated June 23, 2016. The purposes of this RCAP are to identify revisions to the CAP since it was issued and to provide an explanatory document for public review.

Background

The stretch of Interstate 5 next to the site was constructed in 1961. Hylebos Creek was re-routed to its current location as part of this construction. The freeway construction and re-routing of Hylebos Creek cut the site off from the adjoining agricultural land to the east. Thereafter, fill was imported to bring the site up to grade with Highway 99. This fill included industrial waste from USGI's Tacoma, Washington plant. From 1959 through 1973, the USGI Tacoma plant used ASARCO slag as a raw material for mineral fiber production. ASARCO was a copper smelter that operated at nearby Ruston from 1890 to 1986. ASARCO's copper smelting process concentrated arsenic in the slag. Baghouse dust, "shot" (small, rounded, glassy particles broken off from the ends of the mineral fibers during extrusion process), and off-specification product from the Tacoma plant were reportedly used as fill at the Highway 99 site from 1971 through 1973. USGI did not own the property during the period when this fill was used.

In the early 1980s, USGI became aware of the association between ASARCO slag and arsenic contamination. Subsequently, on August 18, 1982, USGI purchased the property where fill had been placed. That same year USGI voluntarily approached the Washington State Department of Ecology (Ecology) to negotiate an administrative process to govern the removal of industrial fill from the property. Soil and groundwater cleanup standards had not been established in Washington State at this time. Accordingly, Agreed Order No. DE 84-506 established project-specific arsenic cleanup standards for soil at 0.5 milligrams per liter (mg/L) by the Extraction Procedure (EP) Toxicity (leaching) method and for groundwater at 0.5 mg/L. The 1984 Agreed Order also required USGI to conduct post-cleanup groundwater monitoring.

Initial cleanup actions at the Highway 99 site occurred between October 12, 1984 and January 25, 1985 with excavation and off-site disposal of an estimated 20,000 to 30,000 cubic yards of material. Ecology stated that soil cleanup standards established at the time for the project were met. The site subsequently underwent commercial development and by 1989 had been developed to its current configuration. USGI maintained responsibility for groundwater verification monitoring, as specified in Agreed Order No. DE 87-506 issued in 1987. The 1987 Agreed Order retained the 0.5 mg/L groundwater cleanup level for the site. Post-source removal action verification groundwater sampling was performed by USGI from June 1985 to April 2006.

The Model Toxics Control Act (MTCA) was enacted and went into effect in March 1989. In 1991, Ecology established MTCA "Method A" arsenic cleanup levels of 20 milligrams per kilogram (mg/kg) for soil and 5 micrograms per liter ($\mu\text{g/L}$) for groundwater. The groundwater cleanup

level has subsequently been revised to 8 µg/L in consideration of new data regarding naturally-occurring background concentrations.

In 2006, Ecology required that USGI conduct a soil and groundwater assessment for arsenic in the vicinity of well 99-1 – generally referred to as the groundwater hot spot area. This assessment showed that arsenic in soil and groundwater exceeded MTCA Method A cleanup standards. On March 30, 2007, Ecology issued a letter naming USGI as a potentially liable party for the release of arsenic at the Highway 99 site, which led to Agreed Order DE 6333, issued in 2009. The Agreed Order required completing a Remedial Investigation (RI), Feasibility Study (FS), and CAP.

The RI, FS, and CAP focused primarily on an area referred to as the “Core Remediation Area” in which well 99-1 is located. This area consists of two presently vacant parcels (previously occupied by Discount RV), located between Kanopy Kingdom (addressed as 7110 Pacific Highway E.) on the north, and a property previously occupied by Freeway Trailer (addressed as 7100 Pacific Highway E) on the south. Freeway Trailer has since been purchased by Washington State Department of Transportation (WSDOT) in support of planned freeway improvements. WSDOT plans to conduct remedial actions on its property, which is referred to now as the P429 parcel, along with a section of existing WSDOT-owned right-of-way adjacent to the P429 parcel. The P429 parcel and right-of-way together are referred to as P429 Plus property.

Initial Selected Remedial Alternative and Proposed Revised Remedial Alternative of Core Remediation Area

The CAP included implementation of Remedial Alternative 2 of the alternatives evaluated in the Feasibility Study. Key elements of Remedial Alternative 2 included the following:

1. Soil Solidification – Implement in situ solidification (ISS) of hot spot vadose soils in the Core Remediation Area – generally defined as the area where soils exceed 500 mg/kg arsenic - by mass stabilization using a cement-bentonite-iron solidification reagent blend.
2. Remediate Arsenic in the Groundwater – Treat site groundwater using in-situ application of ferrous iron and an oxidant (in-situ chemical oxidation or ISCO) via temporary injection wells in the groundwater hot spot area and introduction trenches upgradient of the Core Remediation Area.
3. Remediate Sediment in Hylebos Creek – Remediate sediment by excavation and offsite disposal.
4. Long-Term Groundwater Monitoring – Confirm long-term performance by monitoring groundwater quality in accordance with the requirements of Washington Administrative Code 173-340-410.

Prior to implementation of the Remedial Alternative 2, an ISCO pilot study for treatment of groundwater was conducted. Implementing the ISCO pilot study at the Highway 99 site was highly complicated and did not reduce arsenic concentrations in groundwater to the levels desired. Based on these findings, an alternative approach to the remedial action was developed. Proposed modifications to the remedial action were initially presented in a Conceptual Design

Report (CDR), which included increasing the area and depth of ISS. Implementing ISS not only in the vadose soils, but also in the high concentration saturated soils, should greatly improve groundwater quality, potentially eliminating the need for additional groundwater remedial actions.

Additional treatment of arsenic in groundwater by in situ methods is also proposed, should follow-up groundwater monitoring indicate arsenic groundwater cleanup levels will not be met in a reasonable timeframe. Zero valent iron (ZVI) is proposed as a more suitable alternative for in situ groundwater treatment than ISCO, as it is considered less challenging to implement and will have much greater level of permanence.

Sediment remediation in Hylebos Creek, long-term groundwater monitoring, and institutional controls as outlined in the CAP remain unchanged.

Assessment of ISS

The work completed to further assess the viability of ISS included conducting a geotechnical field investigation and bench scale treatability study for the Highway 99 site, as well as USGI's nearby Puyallup site. Remediation of USGI's Puyallup site is on a similar path as the Highway 99 site and the two sites are very similar in the contaminant type and source, transport mechanisms, and hydrogeologic conditions. These studies provided physical and analytical data that were used to design and implement an ISS pilot study. Based on the results of these studies, it was determined appropriate to conduct one ISS pilot study at the Puyallup site. The pilot study was conducted in the Fall of 2021 and deemed successful, based on arsenic leachability testing and assessment of the physical properties of the stabilized soil. As a result, it was recommended to proceed with the full-scale design for ISS at the Highway 99 site.

ISS treatment will occur within the Core Remediation Area. Evaluation of the extent to which ISS should be implemented in this area was conducted by updating the computer modelling of arsenic concentrations in soil and completing a disproportionate cost analysis (DCA), the methods and results of which are detailed in this RCAP. The DCA considered four different soil remediation/cleanup levels: 500, 250, 90, and 20 mg/kg. 500 mg/kg is the remediation level used in the initial Cleanup Action Plan. 20 mg/kg is the most conservative, Method A cleanup level. 90 mg/kg is approximately the same as the MTCA Method B cleanup level, which is 88 mg/kg. 250 mg/kg was considered as a reasonably conservative remediation level between the 500 mg/kg remediation level and the Method B cleanup level.

Recommended Revised Remedial Alternative

Soil

Based on the results of the DCA, the ISS will be expanded to target all vadose and saturated soils exceeding 250 mg/kg arsenic. Modelling indicates that targeting soils that exceed 250 mg/kg arsenic will also capture the majority of soil that exceeds 90 mg/kg and a large percentage of soil that exceeds the Method A cleanup level of 20 mg/kg. WSDOT plans to conduct remedial actions involving excavation of all soil on the P429 Plus property that contains arsenic concentrations greater than 20 mg/kg. This work will be conducted in conjunction with the freeway improvements. WSDOT's planned scope of work is detailed in an interim action work plan included in this RCAP as **Appendix A**.

Groundwater

Groundwater will no longer exist within the soil treated by ISS. Groundwater upgradient of the ISS treated area will flow around, rather than through the stabilized soil containing arsenic. Implementing ISS in high arsenic concentration saturated soils will immediately show significant improvement in groundwater quality. Residual arsenic concentrations in groundwater downgradient of the ISS treated area will decline through natural attenuation mechanisms.

The rate and success of natural attenuation following implementation of the ISS will be evaluated to determine the need for additional groundwater treatment. ISS is targeted to be implemented during the spring of 2023. Immediately following the ISS, groundwater will be monitored downgradient of the ISS treatment area on a quarterly basis. It is anticipated that the WSDOT P429 Plus property will be remediated in the year 2024. Once remediation of the WSDOT P429 Plus property has been completed and new monitoring wells installed, quarterly groundwater monitoring will also include that property and continue for two more years. At the end of the two years of groundwater monitoring following soil excavation on the WSDOT property, the groundwater data will be evaluated with regard to the progress in achieving groundwater cleanup levels. If this assessment determines that groundwater cleanup levels will likely not be achieved throughout the site within a 20-year timeframe, then a program of in situ treatment will be initiated. This RCAP includes in situ treatment (ZVI injection) within the Core Remediation Area. Since WSDOT will be removing all soil greater than 20 mg/kg from its property, the need for future groundwater treatment on that property is not planned.

Section 1

Introduction

1.1 Purpose

This document presents the Revised Cleanup Action Plan (RCAP) for USG Corporation's (USG) USG Interiors LLC (USGI) Highway 99 site (Cleanup Site ID 3618) generally located at 7110 Pacific Highway East in Milton, Washington (site or Highway 99 site). The site location is shown on **Figure 1**. This RCAP revises the Cleanup Action Plan (CAP) dated June 23, 2016 (Ecology 2016). The purposes of this RCAP are to identify revisions to the CAP since it was issued and to provide an explanatory document for public review. More specifically, this plan:

- Describes the site;
- Summarizes current site conditions;
- Describes the cleanup action alternative originally selected for the site;
- Describes studies completed subsequent to the issuance of the CAP and the results of those studies;
- Describes the revised cleanup actions considered and which one was selected as a result of those subsequent studies and the rationale for its selection based on a disproportionate cost analysis (DCA);
- Identifies site-specific cleanup levels and points of compliance for the contaminant of concern (arsenic) and each medium of concern for the proposed cleanup action;
- Identifies applicable state and federal laws for the proposed cleanup action;
- Identifies residual contamination remaining on the site after cleanup and restrictions on future uses and activities at the site to ensure continued protection of human health and the environment;
- Discusses compliance monitoring requirements; and
- Presents the schedule for implementing the RCAP.

1.2 Regulatory Framework and Background

Washington State Department of Ecology (Ecology) published the June 23, 2016 CAP for the Highway 99 site under Agreed Order DE 6333 with USGI in accordance with the Model Toxics Control Act (MTCA), Chapter 70.105D of the Revised Code of Washington (RCW) (now Chapter 70A.305). The CAP for the site presented the preferred remedial alternative as developed during the Feasibility Study (FS), based on information available at the time it was completed. Remedial Action Alternative 2 was selected and included the following components:

- A supplemental subsurface investigation to further delineate the “hot spot” area (soils containing greater than 500 milligrams per kilogram [mg/kg] arsenic), as generally situated within the Discount RV parcel shown in **Figure 2**.
- In situ solidification/stabilization (ISS) of arsenic in soil in the hot spot area (vadose soils). Bench-scale treatability testing would be conducted to determine the appropriate ISS mix.
- Treatment of arsenic-contaminated groundwater located within what is termed the groundwater hot spot, which is in the vicinity of groundwater monitoring well 99-1, by in-situ chemical oxidation (ISCO) using an array of vertical injection wells. A groundwater remediation level of 500 micrograms per liter (µg/L) was assumed. Bench-scale and pilot testing would be conducted prior to conducting this element of the cleanup action.
- Treatment of the remainder of the groundwater arsenic plume in the Core Remediation Area, generally defined as the Discount RV parcel and extending north partially into the adjacent Kanopy Kingdom parcel (**Figure 2**), with ISCO using injection trenches.
- Installation of permeable pavement to allow precipitation to infiltrate, which in turn would promote oxidizing groundwater conditions and minimize arsenic mobility.
- Use long-term groundwater monitoring to ensure that monitored natural attenuation (MNA) is sufficient to effect the decline of arsenic concentrations over time as geochemical conditions promote the stability of the iron-arsenic oxyhydroxide co-precipitates formed during ISCO treatment.
- Excavation of contaminated sediment from Hylebos Creek.

On June 24 2016, Ecology issued Agreed Order DE 11099, which required implementation of the remedial action as outlined above. In December 2016 the hot spot delineation was conducted; ISS and ISCO bench scale studies were conducted in 2017 (CDM Smith 2018). In November 2018 through March 2019 an ISCO pilot study was performed at the site (CDM Smith 2020b). Implementing the ISCO pilot study was found to be highly complicated and did not reduce arsenic concentrations in groundwater to the levels desired. Based on the findings of this pilot study, an alternative approach to the remedial action was developed. Proposed modifications to the remedial action were presented in a Conceptual Design Report (CDR) (CDM Smith 2020a). The primary modification included increasing the volume of soils to be treated by conducting ISS on all soils greater than 500 mg/kg in the vadose zone and saturated zone based on computer modeling of arsenic concentrations in soils.

Groundwater will no longer exist within soil treated by ISS. Groundwater upgradient of the ISS treated area will flow around, rather than through the stabilized soil containing arsenic. Implementing ISS in high arsenic concentration saturated soils will immediately show significant improvement in groundwater quality. Residual arsenic concentrations in groundwater downgradient of the ISS treated area will decline by the natural attenuation mechanisms. Reliance on ISS as a methodology to remediate soil and, ultimately groundwater, is further evaluated in this RCAP. Based on this evaluation, the volume of soil treated by ISS was further increased, as discussed in later sections of this document. After a reasonable period of time has

elapsed to appropriately evaluate the effects of the ISS on groundwater, the need for additional groundwater treatment by in situ methods will be evaluated, and implemented, if it is determined that source control by ISS will not reduce arsenic concentrations to meet groundwater standards within a reasonable time period.

In addition to the revisions to the CAP as summarized above, the Washington State Department of Transportation (WSDOT) purchased property to the south for planned freeway improvements. WSDOT refers to the parcel as P429. (Figure 2). A section of existing WSDOT-owned right-of-way adjacent to parcel P429 is also included in this remediation. The P429 parcel and right-of-way together are referred to as the P429 Plus property. This property is outside the planned area of ISS (hot spot/core remediation area) but is a part of the site (see Section 2.1). WSDOT plans to conduct remedial actions in conjunction with the freeway improvements. The WSDOT project includes rerouting Hylebos Creek by moving the present undercrossing about 300 feet south where it will enter into WSDOT's P429 parcel. In accordance with an agreement between WSDOT and USGI, WSDOT will also be conducting excavation of the arsenic-contaminated sediment in Hylebos Creek. Since WSDOT's work already impacts Hylebos Creek excavation of the creek bed sediment it will be more expedient and cost effective for WSDOT to conduct the sediment cleanup in conjunction with their planned freeway improvements. The other major modification to the remedial action is that soil excavation will occur on the adjacent WSDOT P429 Plus property. WSDOT plans to conduct excavation of all soils exceeding 20 mg/kg on the P429 Plus property in conjunction with construction during the SR 167/I-5 to SR 509 – New Expressway Stage 1b project.

1.3 Report Organization

This RCAP has been organized into the following sections:

- **Section 1 – Introduction:** This section provides the purpose and scope of the RCAP and the regulatory framework which cleanup actions for the site are currently being undertaken.
- **Section 2 – Site Description and Remedial Investigation Summary:** This section describes the Highway 99 site, its history, interim actions completed, physical setting, nature and extent of contamination, and describes the conceptual site model (CSM).
- **Section 3 – Human Health and Environmental Concerns:** This section provides the exposure pathway assessment, contaminants of concern, cleanup levels, and remediation levels.
- **Section 4 – Initial Proposed Cleanup Alternative and Subsequent Pilot Study:** This section describes the cleanup alternative selected in the CAP and the results of the groundwater pilot study that led to this RCAP.
- **Section 5 – Remedial Action Modifications and Justification:** This section describes the revised cleanup action alternatives considered, their conceptual design, and summarizes results of the geotechnical, bench scale, and pilot studies completed.

- **Section 6 – Disproportionate Cost Analysis:** This section provides a description of the methodology to complete the disproportionate cost analysis (DCA), develops the DCA, and results of the DCA.
- **Section 7 – Recommended Remedial Alternative:** This section presents the recommended remedial alternative, and describes, relevant and appropriate requirements, remnant contamination, the schedule for implementation, restoration timeline, engineering design requirements, compliance monitoring, institutional controls, and public participation.
- **Section 8 – References:** This section lists the documents cited in this RCAP.
- **Appendix A – Interim Action Work Plan, USG Highway 99 Site Contaminated Creek Sediment Removal and Parcel P429 Plus Soil Excavation.**
- **Appendix B – Alternatives 1 through 4 Remediation Cost Estimates**

Section 2

Site Description and Remedial Investigation Summary

2.1 Location and Description

USGI's Highway 99 site is located in a commercial area situated between Pacific Highway East (aka Highway 99) and Interstate 5 (I-5) in Milton, Washington as shown on **Figure 1**. The western edge of the site is Pacific Highway East. I-5 marks the eastern boundary of the site. Hylebos Creek and 70th Avenue East mark the southern boundary of the site.

The site encompasses 8 parcels. The northernmost parcel is a 0.58-acre property previously occupied by Linwood Custom Homes and has an address of 7220 Pacific Highway East. To the south of this is a 1.16-acre parcel owned by East Fork Corp. and is occupied by General Trailer Co. (7200 Pacific Highway East). South of General Trailer are four parcels that total 1.24 acres and are owned by Freeway Sales (7110 Pacific Highway East). The northern two of these four parcels are occupied by Kanopy Kingdom and the southern two parcels were, until recently, occupied by Discount RV (the property is now vacant, but for simplicity and consistency, will continue to be referred to as Discount RV). To the south of Discount RV are two parcels that total 2.66 acres, which are presently vacant (7100 Pacific Highway East). The parcels were previously occupied by Freeway Trailer, but were recently purchased by WSDOT for planned freeway improvements. The WSDOT-owned parcels are referred to as the P429 and P428 parcels. The WSDOT-owned right-of-way is situated on the west side of the WSDOT P429 and P428 parcels, as well as a portion of the Discount RV parcel. **Figure 2** shows the parcel lines and areas occupied by these entities.

The western portion of the site is relatively flat, but the site drops off sharply on the east where the surface slopes down either to Hylebos Creek or a roadside ditch. The central portion of the site (i.e., Kanopy Kingdom/Discount RV) is located at an elevation of approximately 20 feet above Mean Sea Level (MSL).

2.2 Site History

The historical summary of the site that follows is based on an interpretation of historical aerial photographs, documents at Ecology, and a title search.

An aerial photograph from 1949 shows the site being used for residential and agricultural purposes. 12th Street East, an east-west road that connected the City of Milton proper with Pacific Highway East, is present (**Figure 2**). The right-of-way of this road was the northern portion of the current WSDOT P429 parcel, on the south side of Discount RV.

I-5 was constructed in this area in 1961. Hylebos Creek was re-routed to its current location as part of this construction. The freeway construction and re-routing of Hylebos Creek cut the site

off from the adjoining agricultural land to the east. Freeway construction also did not make a provision for continued use of 12th Street East, so it was abandoned at that time.

Fill was imported to bring the site up to grade with Pacific Highway East. This fill included industrial waste from USGI's Tacoma, Washington plant. From 1959 through 1973, the USGI Tacoma plant used ASARCO slag as a raw material for mineral fiber production. The ASARCO copper smelter operated at nearby Ruston from 1890 to 1986. ASARCO's copper smelting process concentrated arsenic in the slag. Baghouse dust, "shot" (small, rounded, glassy particles broken off from the ends of the mineral fibers during extrusion process), and off-specification product from the Tacoma plant were reportedly used as fill at the Highway 99 site from 1971 through 1973 (Ecology 1986). USGI did not own the property during the period when this fill was used.

In the early 1980s, USGI became aware of the association between ASARCO slag and arsenic contamination. Subsequently, USGI purchased what is now the property owned by Freeway Sales from Partner's Financial Incorporated on August 18, 1982. That same year USGI voluntarily approached Ecology to negotiate an administrative process to govern the removal of industrial fill from the property. Soil and groundwater cleanup standards had not been established in Washington State at this time. Accordingly, Agreed Order No. DE 84-506 established project-specific arsenic cleanup standards for soil at 0.5 milligrams per liter [mg/L] by the Extraction Procedure (EP) Toxicity (leaching) method, and groundwater at 0.5 mg/L. The 1984 Agreed Order also required USGI to conduct post-cleanup groundwater monitoring.

The initial cleanup action for the Highway 99 site occurred between October 12, 1984 and January 25, 1985 (Ecology 1986). Detailed records of the cleanup, termed the source removal action, have not been located. Ecology estimated that 20,000 to 30,000 cubic yards of material were excavated and disposed of off-site (Ecology 1986). The material excavated from the Freeway Sales property is inferred to include soil fill mixed with waste insulation, shot, baghouse dust, and native soil exceeding the cleanup standard in effect at the time. Native soil exceeding the project-specific cleanup standard was reportedly excavated in the vicinity of monitoring well 99-1 (see **Figure 2** and **Figure 3** for the well location). This is referred to as the contaminant source area. Ecology (1986) stated that soil cleanup standards for the project were met.

Historical aerial photographs show that the property was cleared and re-graded in June 1985 (approximately 5 months after completion of the source removal action). The site subsequently underwent commercial development and by 1989 had been developed to its current configuration. USGI maintained responsibility for groundwater verification monitoring, as specified in Agreed Order No. DE 87-506 issued in 1987. The 1987 Agreed Order retained the 0.5 mg/L groundwater cleanup level for the site. Post-source removal action verification groundwater sampling was performed by USGI from June 1985 to April 2006.

MTCA was enacted and went into effect in March 1989. MTCA governs state-led environmental cleanups in Washington State. In 1991, Ecology established MTCA "Method A" arsenic cleanup levels of 20 mg/kg for soil and 5 micrograms per liter ($\mu\text{g/L}$) for groundwater. Both of these cleanup levels account for concentrations that were considered to be natural background at the time. Recently, Ecology revised the background concentration for arsenic in groundwater to 8 $\mu\text{g/L}$, which is the current Method A cleanup level.

In 2006, Ecology required that USGI conduct a soil and groundwater assessment for arsenic in the vicinity of well 99-1. This assessment showed that arsenic in soil and groundwater exceeded MTCA Method A cleanup standards. On March 30, 2007, Ecology issued a letter naming USGI as a potentially liable party for the release of arsenic at the Highway 99 site, which led to Agreed Order DE 6333, issued in 2009, which required completing a Remedial Investigation (RI), FS, and CAP.

2.3 Physical Setting

2.3.1 Geology

The site is situated in a north-trending valley that is the floodplain of Hylebos Creek and its tributaries. The valley is located just north of the lower Puyallup River valley. Alluvium associated with Hylebos Creek and the lower Puyallup River forms the uppermost native soil at the property. The alluvium consists predominantly of overbank flood, slack water, and bar accretion deposits. Glacially consolidated glacial drift and interglacial deposits hundreds to thousands of feet thick underlie the alluvial deposits. Fife Heights, the upland region northwest of the property, is largely comprised of glacial drift.

The specific site geology is summarized in geologic cross-sections A - A' and B - B' (**Figure 4** and **Figure 5**, respectively). The cross-section locations are shown on **Figure 3**. Generalized stratigraphy consists of fill overlying alluvium over glacial drift. Each of these units is described in more detail below.

Fill

The site area was originally low-lying farmland and fill was brought in during the 1960s and 1970s to bring the site up to grade with Highway 99 for development purposes. Fill at the site is differentiated into three units, described from youngest to oldest:

- Fill-3: Fill used as backfill for the 1984/1985 source removal action
- Fill-2: Fill containing industrial waste from USGI's Tacoma plant
- Fill-1: Undifferentiated fill

Fill-3 was placed during remedial excavation backfilling in 1985. The soil consists of fine- to coarse-grained silty sand with gravel and silty sand (SM). The Fill-3 unit soil extends from the ground surface to maximum depths ranging from 4.5 to 14 feet below ground surface (bgs).

Fill-2 includes soil mixed with manmade materials. Fill-2 is likely residual fill representative of material not captured during USGI's 1984/1985 soil removal action. These materials include what appears to be ASARCO slag, black and green glassy needle-like grains, glass-like gravel-sized particles, and insulation debris. The ASARCO slag is distinguishable in that it does not appear to be processed like the other manmade materials, such as those generated by USGI. The material is associated with soil types that include poorly graded sand (SP) and sandy silt (ML). The Fill-2 material was encountered in borings A6, B6, B7, and C7 (Boring locations are shown on **Figure 3**) at depths ranging between 4.5 and 12.5 feet bgs.

Fill-1 includes soil that was placed during initial development of the site and consists of silt (ML), sandy silt (ML), organic silt (OH), and silty sand (SM) with traces of debris, including wood chips and gravel. The Fill-1 soil extends to a maximum depth of 9 feet bgs.

Alluvium

Alluvium underlies fill at the site and pinches out to the west. The alluvium can be subdivided into two units based on soil type and hydraulic properties, including:

- Upper Silt Unit
- Alluvial Aquifer

The Upper Silt Unit is the uppermost alluvial unit. Soil in this unit is comprised of dark brown to gray-brown silt and sandy silt (ML), often with bedding laminations. Minor amounts of wood fragments and rootlets are typically present. The Upper Silt Unit ranges in thickness from 1 to 6 feet. The presence of silt and organic matter indicates deposition in a lower energy depositional environment, such as wetlands.

The Alluvial Aquifer extends from the bottom of the Upper Silt Unit to the top of the Lower Silt Aquitard. Soil in the Alluvial Aquifer consists of fine-grained silty sand (SM), fine- to medium-grained sand (SP), and well-graded sand (SW). The soil includes minor silt (ML) interbeds, which are typically less than 0.25 inch thick. The thickness of the Alluvial Aquifer is approximately 30 feet in the area of the groundwater hot spot.

Glacial Units

Glacial sediments underlie the alluvium east of Pacific Highway East. At monitoring well 12 (MW-12), situated on the west side of Pacific Highway East, west of the site, glacial sediments occurred directly beneath fill.

The glacial sediments are subdivided into the following units based on hydraulic properties:

- Lower Silt Aquitard
- Glacial Aquifer

Lower Silt Aquitard

The Lower Silt Aquitard underlies the Alluvial Aquifer. Soil in this unit consists of greenish-gray silt (MH or ML). The fine-grained nature of the soil indicates a low energy lacustrine (or possibly glacio-marine) depositional environment.

The total thickness of the Lower Silt Aquitard ranges from approximately 5 to 15 feet. The Alluvial Aquifer/Lower Silt Aquitard contact dips sharply to the east as shown on **Figure 5**.

Glacial Aquifer

Water-bearing sand (SP), silty gravel (GM), and silty sand with gravel (SM) underlie the Lower Silt Aquitard. This soil is classified as glacial drift based on texture and low organic content. The upper 10 feet of this soil is not consolidated and may have been deposited in a glaciofluvial depositional environment (recessional outwash). Below 52.5 feet bgs at MW-9, the soil changes to

very dense silty sand (SM) and silty gravel that has a till-like texture. This consolidated soil is interpreted as glacial till.

2.3.2 Hydrogeology

Alluvial Aquifer

Groundwater occurs under unconfined conditions within sand and silty sand of the Alluvial Aquifer. The low permeability soil of the Lower Silt Aquitard acts as a lower confining layer to the Alluvial Aquifer, restricting vertical flow. During the RI, groundwater was encountered at depths ranging from 4 to 14 feet bgs.

A groundwater elevation contour map for the Alluvial Aquifer, based on the July 15, 2010 depth to groundwater measurements, is shown on **Figure 6**. The contours indicate that groundwater flows east toward Hylebos Creek and south parallel to the creek. The horizontal hydraulic gradient ranges from 0.003 foot/foot in the central area of the site, steepening to 0.03 foot/foot at the west bank of Hylebos Creek.

The vertical hydraulic gradient within the Alluvial Aquifer was calculated at the MW-5/MW-8 and well 99-1/MW-7 well pairs. Wells in these pairs are completed within the shallow and deeper portions of the Alluvial Aquifer, respectively. The results of the vertical hydraulic gradient calculations indicate upward vertical hydraulic gradients ranging from 0.022 to 0.035 foot/foot, based on the July 15, 2010 groundwater elevation measurements. The upward gradient indicates significant potential for groundwater flow from the deeper to shallower reaches of the aquifer.

The predominant soil types in the Alluvial Aquifer are fine-grained silty sand (SM) and sand (SP). The hydraulic conductivity of these soils ranges from 0.3 to 30 feet/day, based on literature-derived hydraulic conductivity values for silty sand and fine sand (Anderson and Woessner 1992).

Layers of coarser-grained sands (SP and SW) are also present within the Alluvial Aquifer. These sands have hydraulic conductivities ranging from 130 to 200 feet/day, based on an estimate using the Hazen (1911) method and the grain size distribution results for representative soil samples.

The average linear velocity (seepage velocity) of groundwater flow in the Alluvial Aquifer is estimated to be about 2 feet/day in the central area of the site. This is considered to be a maximum seepage velocity estimate and is based on a hydraulic conductivity of 200 feet/day, which is the maximum hydraulic conductivity estimated for the layers of coarser-grained sand present within the deeper Alluvial Aquifer. The seepage velocity for the fine-grained silty sand (SM) and sand (SP), typical of the shallow Alluvial Aquifer, is expected to be much lower.

Glacial Aquifer

The head differential between well pairs screened within the Alluvial Aquifer and the Glacial Aquifer (well 99-1 and MW-9, respectively) was 6.58 feet based on the July 15, 2010 measurements. This large head differential indicates that the Glacial Aquifer is confined and exerting considerable hydraulic pressure on the overlying Lower Silt Aquitard. The different hydraulic and geochemical characteristics of the Glacial Aquifer and the Alluvial Aquifer indicate that the two aquifers are not in hydraulic communication.

The Glacial Aquifer is comprised of soil types ranging from silty sand (SM) to silty gravel (GM). Based on these soil types, the seepage velocity in the Glacial Aquifer is estimated to range from as low as 20 feet/day to as high as 70,000 feet/day. Typical hydraulic conductivity values for glacial aquifers in the site vicinity are at the lower end of this range.

2.3.3 Groundwater/Surface Water Interaction

The nature of interaction between the Alluvial Aquifer and Hylebos Creek is difficult to characterize because of the 1961 diversion of Hylebos Creek during construction of I-5 into its current channelized section. The base of the channelized section adjacent to the contaminant source area intersects the Alluvial Aquifer. Alluvial Aquifer groundwater contours bend sharply adjacent to Hylebos Creek, indicating the Alluvial Aquifer does flow into Hylebos Creek (**Figure 6**). However, the very steep Alluvial Aquifer gradient of 0.03 foot/foot at the west bank of Hylebos Creek indicates there is a weak hydraulic connection between the Alluvial Aquifer and Hylebos Creek adjacent to the contaminant source area. This channelized section of Hylebos Creek does not appear to function as a true groundwater discharge area that would be found in an unconfined aquifer and an unmodified stream.

2.4 Nature and Extent of Contamination

Previous work conducted at the site to meet the requirements of Agreed Order No. DE 6333 includes an RI, the results of which are presented in a RI Report (CDM Smith 2016a). A soil hot spot characterization was conducted in 2016 to comply with Agreed Order DE 11099 (CDM Smith 2018). Additional soil data were obtained during a geotechnical field investigation and bench scale treatability study in 2021 (CDM Smith 2021). **Figure 2** shows the locations where groundwater samples were collected as a part of the RI. **Figure 3** shows the locations of boring, monitoring wells, and other subsurface explorations in the area referred to as the hot spot/core remediation area.

2.4.1 Distribution of Arsenic in Soil

A three-dimensional model of arsenic in soil throughout the site using all data collected to date was created using Leapfrog Works® (Leapfrog) software version 3.0.1. The Leapfrog model incorporated the following datasets: environmental borings, arsenic analytical results of soil samples, topographic data, an aerial photo, and a plan view figure.

The arsenic soil analytical data was interpolated using Leapfrog's radial basis function (mathematically equivalent to kriging) to create iso-value surfaces of the arsenic-impacted soils. These interpolated volumes from the iso-value surfaces were used to develop the ISS conceptual design that is further discussed in later sections of this RCAP, as well as the soil removal action that is planned by WSDOT on its parcel. Plan and cross section views of the interpolated plume are presented on **Figures 7** through **9**. Please note that the Leapfrog software is limited in presenting three-dimensional plume data for two-dimensional visualization. Colors associated with the plume concentrations in **Figure 7** may not directly reflect those identified in the legend due to overlying data. For the most accurate correlation between the plume colors and the legend colors, please refer to the cross-sections in **Figure 8** and **Figure 9**.

Core Remediation Area

In general, arsenic concentrations are relatively low at ground surface to about 5 feet bgs, reflecting the 1984/1985 remedial action performed by USG that removed waste fill and some native soil on the Discount RV parcels. These materials were replaced with imported fill as part of the site restoration.

In general, the highest arsenic concentrations in soil occur in an oval-shaped area along the west side of the Discount RV property (**Figure 7**); this area has been identified as the soil hot spot. Soil with high arsenic concentrations also extend into the saturated zone and so is in direct contact with groundwater. Arsenic concentrations over 1,000 mg/kg occur in some soil samples. For example, the 15.5-foot sample collected from boring AA63 contained arsenic at a concentration of 10,770 mg/kg. The 12-foot soil sample from B6 (Fill-2 material) contained arsenic at a concentration of 13,086 mg/kg. A 14-foot sample collected from boring B5 contained 7,430 mg/kg arsenic. A 10.5-foot sample collected from AA60 contained 5,501 mg/kg arsenic. An 11.5-foot sample collected from B63 contained 4,502 mg/kg arsenic and a 7.5-foot sample collected from BB40 contained 2,622 mg/kg arsenic.¹ With the exception of BB40, these borings are all located west of well 99-1. The depth to groundwater is about 8 to 8.5 feet bgs. Arsenic concentrations in soil attenuate at depths below 16 feet bgs.

WSDOT P429 Plus Property

Figures 7 through **9** also show the modeled distribution of arsenic across WSDOT's P429 Plus property. While arsenic concentrations are generally lower than on the Discount RV property, two lobes with elevated arsenic concentrations appear to extend southward into the WSDOT Plus property. With the exception of a sample collected from boring C8 at a depth of 5 feet bgs, which contained 10,450 mg/kg arsenic, arsenic concentrations in samples collected from the WSDOT property were less than 500 mg/kg.

2.4.2 Distribution of Arsenic in Groundwater

The distribution of dissolved total arsenic in groundwater at the site based on samples collected during the 2010-2012 time period is shown in **Figure 10**. The highest arsenic concentrations were detected in the area bound by wells MW-4, MW-5, 99-1, MW-1, and MW-3. The dissolved arsenic concentrations in these wells ranged from 630 to 2,490 µg/L, with the greatest arsenic concentration in monitoring well 99-1 (the original contaminant source area). Arsenic concentrations in groundwater prior to the ISCO pilot test (December 2018) were similar; however, post air sparging, the arsenic concentration in well M1, located in the soil hot spot area (**Figure 3**), increased from 1,600 µg/L to 2,900 µg/L. From monitoring well 99-1 arsenic migrates in the direction of groundwater flow to the east and south.

Arsenic concentrations in the Alluvial Aquifer attenuate with distance from monitoring well 99-1. However, arsenic concentrations in all Alluvial Aquifer monitoring wells exceed the MTCA Method A cleanup level of 8 µg/L, including the MW-13 (south end of WSDOT P429 property) and MW-16 (Linwood Custom Homes) locations. Elevated arsenic concentrations extend east of

¹ Some samples analyzed using an XRF and results corrected using an equation determined during the RI. All samples reported in units of mg/kg, although the XRF reports in units of parts per million, which is essentially these same.

Hylebos Creek. MW-10, located east of Hylebos Creek, had a dissolved arsenic concentration of 366 µg/L.

Arsenic concentrations in groundwater in the deeper Alluvial Aquifer (MW-7 and MW-8) are two orders of magnitude lower than arsenic concentrations in groundwater from the shallow Alluvial Aquifer and just slightly above the MTCA Method A cleanup level, indicating that arsenic attenuates rapidly with depth within this aquifer. Dissolved arsenic was detected at a concentration of 44 µg/L in the Glacial Aquifer (MW-9).

2.4.3 Distribution of Arsenic in Sediment

Six of the 14 sediment samples collected from the Hylebos Creek and analyzed for arsenic exceeded the sediment cleanup level (see Section 3.2.1). Arsenic concentrations in these samples ranged from 14.6 mg/kg to 295 mg/kg. Arsenic cleanup level exceedances occurred in one or both of the B (west bank) and C (bottom) samples collected at locations SED-3, SED-4, SED-5 and SED-6. These data indicate that dissolved arsenic in shallow groundwater at the site is discharging to Hylebos Creek and adsorbing onto sediment or co-precipitating with iron onto sediment at the groundwater/surface water interface. The northern limit of the sediment contamination is bound by samples collected at SED-1 and SED-2, and the southern limit by samples collected at SED-7.

2.5 Conceptual Site Model

A CSM is a representation of an environmental system and the physical and chemical processes that control the transport and fate of contaminants through environmental media to environmental receptors and their most likely exposure modes. The CSM for the Highway 99 site is described below.

Soil boring data indicate that arsenic concentrations within the Core Remediation Area are generally low (i.e., less than 20 mg/kg) within the first 5 feet; arsenic concentrations then increase in depth, with the highest arsenic concentrations generally occurring within the 10 to 16 foot interval. This distribution reflects the 1984/1985 contaminant source removal action as the shallower industrial waste fill was removed and replaced with clean soil fill. Arsenic concentrations in the residual Fill-2 are highly variable. However, elevated arsenic concentrations at depth are most typically encountered in Fill-1 or alluvium underlying the base of the 1984/1985 contaminant source removal action. The deeper arsenic contamination in the alluvial unit is interpreted to have leached downward out of the Fill-2 unit and adsorbed onto the underlying soil.

Arsenic fate and transport at the site were evaluated in the RI report (CDM Smith 2016a). The fate and transport findings are summarized below:

- Arsenic in groundwater exists predominantly in the reduced arsenite (As III) form at the site, although over time the arsenic is predicted to oxidize to the less mobile arsenate (As V) form.
- Iron and arsenic concentrations in groundwater at the site are likely controlled by ferric oxyhydroxides based on site-specific geochemical modeling performed for the RI.

- Redox conditions at the site are not in equilibrium with arsenic, dissolved oxygen, or total organic carbon due to the presence of a redox gradient.
- Arsenic transport in the Alluvial Aquifer is at least 34 times slower than the groundwater velocity, resulting in long travel times for arsenic to migrate downgradient from the contaminant source area. This is a result of adsorption of arsenic to the surfaces of iron-bearing minerals and co-precipitation with iron hydroxides, which retards the transport of arsenic relative to groundwater. Using the minimum partitioning coefficient (Kd) of 4 liters per kilogram (L/kg), it would take approximately 17 years for arsenic to travel 50 feet from well 99-1 to the groundwater beneath Hylebos Creek, and using the median Kd of 44 L/kg, it would take approximately 25 years for arsenic to travel this distance.
- Shallow groundwater from the site appears to discharge into Hylebos Creek. Sediment data collected from the bank and center of Hylebos Creek show elevated arsenic concentrations downgradient of where the highest concentrations of arsenic were detected in groundwater at the site. This suggests that dissolved arsenic in groundwater is either adsorbing onto sediment or co-precipitating with iron onto sediment at the groundwater/surface water interface.

Figure 11 shows the conceptual site model for the site. The principal threat to receptors is posed by residual arsenic in soil leaching to groundwater and dissolved arsenic in groundwater. Dissolved arsenic is then transported via the groundwater pathway to Hylebos Creek surface water and sediment.

Impacted groundwater in the Alluvial Aquifer does not pose an imminent threat to human health via the drinking water pathway. Water supply for the site and surrounding area is supplied by deep groundwater supply wells hydraulically separated from the Alluvial Aquifer.

Section 3

Human Health and Environmental Concerns

3.1 Media and Contaminant of Concern

Soil, groundwater, and sediment are the media of concern for the cleanup action. The contaminant of concern at the site is arsenic.

3.2 Cleanup Standards Established for the Site

As defined in Washington Administrative Code (WAC) 173-340-700, cleanup standards for the site include establishing cleanup levels and the points of compliance at which those cleanup levels will be attained. The cleanup standards for the site have been established in accordance with WAC 173-340-700 through 173-340-760, and are protective of human health and the environment and comply with the applicable or relevant and appropriate requirements (ARARs) defined for the site.

3.2.1 Cleanup Levels

Cleanup levels are the concentrations of the contaminants of concern that will be met for the media of concern at the points of compliance defined for the site to meet MTCA requirements. The soil, groundwater, and sediment cleanup levels for arsenic are summarized in **Table 3-1**:

Table 3-1 Arsenic Cleanup Levels

Media	Basis	Cleanup Level
Soil	MTCA Method A (Background)	20 mg/kg
Groundwater	MTCA Method A (Background)	8 µg/L
Sediment	WAC 173-204	14 mg/kg ^(a)

Note:

^(a) Freshwater sediment cleanup screening levels and sediment cleanup objectives for protection of the benthic community are established in the Sediment Management Standards (WAC 173-204). The freshwater sediment cleanup screening level for arsenic is 120 mg/kg, which is the concentration that minor adverse effects are expected to the benthic community. The freshwater sediment cleanup objective is 14 mg/kg, which is the concentration that no adverse effects are expected to the benthic community.

The MTCA Method A cleanup level is proposed for the WSDOT P429 Plus property soils and the freshwater sediment cleanup objective for sediment in Hylebos Creek. Remediation levels are proposed for soils in the core remediation area and groundwater as described in the following section.

3.2.2 Remediation Levels

The Feasibility Study used remediation levels of 500 mg/kg for soil and 500 µg/L for groundwater to develop the areas requiring focused treatment. This was based on a cost-benefit analysis of the various treatment options evaluated. However, final remediation levels were to be based on the results of bench-scale treatability studies and pilot testing to be conducted as part of the cleanup action. When the ISCO pilot study for groundwater indicated that the treatment

technology was temporary and challenging to implement, especially for groundwater with high arsenic concentrations (see Section 4.3), modifications to the remedial action evaluated expanding the ISS to include saturated soils (Section 5). Treatment of saturated soils then also becomes a groundwater treatment methodology. In addition, because ISS mixes the entire soil column, large quantities of soils with lesser arsenic concentrations are concurrently treated (see Section 6). A cost-benefit analysis was conducted for treatment of soils at varying arsenic concentrations (Section 6). Four different remediation/cleanup levels were considered: 500, 250, 90, and 20 mg/kg. 500 mg/kg is the remediation level used in the initial Cleanup Action Plan. 20 mg/kg is the most conservative, Method A cleanup level. 90 mg/kg is approximately the same as the MTCA Method B cleanup level, which is 88 mg/kg. 250 mg/kg was considered as a reasonably conservative remediation level between the 500 mg/kg remediation level and the Method B cleanup level. This evaluation has resulted in the recommendation to treat all saturated and unsaturated soils exceeding 250 mg/kg arsenic, both in the saturated and unsaturated zones (Section 7).

3.2.3 Points of Compliance

WAC 173-340-200 defines the points of compliance as the locations where cleanup levels (established in accordance with WAC 173-340-720 through 173-340-760) will be attained to meet MTCA requirements. The points of compliance for the cleanup action for soil, groundwater, and sediment are provided in the following subsections.

Soil

The standard point of compliance for soil is the point or points where the soil cleanup level is established. For soil, cleanup levels based on protection of groundwater, the point of compliance is throughout the site (WAC 173 340-740(6)(a)(b)).

In instances where cleanup actions involve containment, as the cleanup action in the Core Remediation Area does, soil cleanup levels will typically not be met at the standard points of compliance. In these instances, compliance is determined if: (1) the selected remedy is permanent to the extent practicable; (2) the remedy is protective of human health; (3) the remedy is protective of ecological receptors; (4) institutional controls are implemented; and (5) compliance monitoring and 5-year periodic reviews are implemented to ensure the long-term integrity of the containment system (WAC 173-340-740(6)(f)).

Groundwater

The standard point of compliance for groundwater is the attainment of groundwater cleanup levels throughout the site to the outer boundary of the hazardous substance plume from the uppermost level of the saturated zone, extending vertically to the lowest depth which could be affected (WAC 173-340-720(8)(a)(b)). However, if the cleanup levels for groundwater cannot be met within a reasonable restoration time frame, conditional points of compliance can be defined in accordance with WAC 173-340-720(8)(c) and an institutional control that precludes the use of groundwater in the shallow water-bearing zone as a potable water source would be implemented at the site.

Between treatment by ISS and, if applicable, in situ treatment of groundwater, it is expected that groundwater cleanup level will be achieved throughout the aquifer within a reasonable timeframe.

Sediment

The point of compliance for sediment in Hylebos Creek is within the biologically active zone in the upper 10 centimeters (approximately upper 4 inches) of sediment.

3.3 Terrestrial Ecological Evaluation

MTCA requires that soil contamination be evaluated for both human health and ecological threats, and that those remedies selected are evaluated for both human health and ecological receptors. The Terrestrial Ecological Evaluations (TEE) is a process that evaluates threats posed by contaminants to ecological receptors. Following characterization of the site, the TEE process requires a determination as to whether the site qualifies for a TEE exclusion. If no exclusion applies, then determination as whether the site qualifies for a simplified TEE or if a site-specific TEE is required.

The site remediation proposed in this RCAP is now divided into two parts: 1) WSDOT's work, which includes excavation of all soils on its property and the creek bed sediments within the biologically active zone which exceed 20 mg/kg arsenic and installation of low permeability barriers at the excavation limits, and 2) ISS of all soils exceeding 250 mg/kg arsenic in the hot spot/core remediation area of the Highway 99 site, along with placement of an asphalt cover across the entire area (see section 7). Based on the planned remedial actions the TEE can be ended because:

1. WSDOT's planned cleanup using the Method A soil cleanup level for arsenic qualifies for Exclusion 4 – Concentrations of hazardous substances in soil are less than or equal to the natural background concentrations of those substances at the point of compliance.
2. For the remainder of the Highway 99 site, Exclusion 2 applies, which is that all soil contamination will be covered by pavement or other physical barriers that will prevent plants or wildlife from being exposed. This exclusion requires institutional controls.

Section 4

Initial Proposed Cleanup Alternative and Subsequent Pilot Study

4.1 Remedial Goals and Objectives

Remedial goals and objectives of the remedial action were established in the 2016 CAP as follows:

- Protect human health and the environment.
- Comply with applicable regulations.
- Satisfy all provisions of the current Agreed Order and receive written notification from Ecology that USGI has completed the remedial activity required by the Agreed Order.

The following remedial action objectives (RAOs) were developed to meet these overall goals:

- **Remedial Action Objective #1 – Remediate Soil Exceeding Cleanup Levels.** Arsenic exceeds MTCA cleanup levels in the core remediation area. An objective of the remedial action is to prevent exposure with engineering and institutional controls or remediate soil to be protective of human health and environmental receptors.
- **Remedial Action Objective #2 – Remediate Arsenic-Impacted Fill Material and Soil.** The contaminant source removal action performed in 1984/1985 was unable to remediate arsenic- impacted fill encountered in boring B6. This area requiring remediation had not been fully delineated. An objective of the remedial action is to delineate and remediate residual fill and soil that is an ongoing source of groundwater contamination.
- **Remedial Action Objective #3 – Remediate Groundwater in the Contaminant Source Area.** Arsenic in groundwater in the former contaminant source (near monitoring well 99-1) is at a relatively high concentration relative to the rest of the plume. An objective of the remedial action is to remediate groundwater in the contaminant source area, identified as the groundwater hot spot, to a concentration that allows use of a cost-effective remedy to achieve RAO 4 or 5.
- **Remedial Action Objective #4 – Achieve MTCA Method A Cleanup Standards for Arsenic in Groundwater at the Standard Point of Compliance.** Remediate groundwater to achieve MTCA Method A cleanup standards for arsenic in groundwater across the entire site. This RAO will be used in conjunction with RAO 3.
- **Remedial Action Objective #5 – Mitigate Arsenic in Groundwater to be Protective of Surface Water or Sediment at a Conditional Point of Compliance.** Set a conditional point of compliance for groundwater at monitoring wells closest to Hylebos Creek. This point of compliance would be protective of Hylebos Creek surface water and sediment. A conditional point of compliance would be established if achieving RAO 4 is technically

impracticable or disproportionately costly. This RAO will be evaluated in conjunction with RAO 3.

- **Remedial Action Objective #6 – Remediate Sediment Exceeding Cleanup Levels.** Sediment in Hylebos Creek exceeds cleanup levels for arsenic. An objective of this remedial action is to remove impacted sediment to protect ecological receptors.

4.2 Initial Proposed Cleanup Alternative

The CAP issued in 2016 for the Highway 99 site included implementation of Remedial Alternative 2 of the alternatives evaluated in the Feasibility Study (CDM Smith 2016b). Key elements of Remedial Alternative 2 included the following:

1. Conduct a subsurface investigation to further delineate the fill/soil hot spot.
2. Conduct a bench-scale study to select the optimal solidification/stabilization (S/S) mix design to treat the fill/soil hot spot.
3. Conduct a bench-scale study to assess soil oxidant demand, select the most effective oxidant, and determine whether metered or batch delivery of the oxidant will work best to treat dissolved arsenic in groundwater.
4. Solidify the fill/soil hot spot by addition of a cement-based reagent and auger mixing.
5. Conduct a pilot test of the ISCO treatment of groundwater, including verification monitoring.
6. Treat the groundwater arsenic hot spot by ISCO. Chemical oxidant would be injected into several injection wells installed at the site around well 99-1.
7. Treat the remainder of the arsenic groundwater plume in the core remediation area also by ISCO. Chemical oxidant would be injected into the subsurface using injection trenches situated at the hydraulically upgradient sides of the site using either batch or metering methods as determined by the bench-scale test.
8. Replace a portion of pavement in the core remediation area with permeable pavement to allow precipitation to infiltrate, promoting oxidizing groundwater conditions and minimizing arsenic mobility.
9. Monitor natural attenuation by collecting groundwater samples to ensure that arsenic concentrations decline over time and geochemical conditions promote the stability of the iron-arsenic oxyhydroxide co-precipitates throughout the arsenic plume.
10. Implement institutional controls such as land use controls and groundwater use restrictions.
11. Construct coffer dams at both ends of the planned sediment cleanup area in Hylebos Creek and then excavate impacted sediment for off-site disposal. Restore the creek channel using clean sand and removing the coffer dams.

Elements 1 through 3 were completed in 2018, which included satisfying RAO #2, the results of which are documented in a report entitled “Hot-Spot Characterization and Bench-Scale Testing, USG Interiors Highway 99 Site” (CDM Smith 2018). Element 5, the ISCO pilot study, was also completed. The following section summarizes the results of that pilot study and the reason the changes to the remedial actions were recommended as a result of the pilot study.

4.3 Groundwater Pilot Study

Between November 2018 and March 2019, a field pilot study was conducted at the site to evaluate the effectiveness of air sparging with an iron amendment in reducing dissolved arsenic concentrations in groundwater at the site (CDM Smith 2020b). Supplemental monitoring wells, two air sparging wells, and two injection wells were installed within the core of the arsenic plume to allow for implementation of the pilot study. Subsequent to the well installations, an air sparging radius of influence (ROI) test was conducted to determine the appropriate injection pressure and flow rate. Following this, in the first week of February 2019, approximately 7,000 gallons of amendment solution consisting of iron as ferrous sulfate heptahydrate and potable water was prepared and injected into the subsurface through the new injection wells. The air sparging pilot test occurred a week later, on February 14 and 15, 2019.

Process monitoring tools were used during the ROI and air sparging tests to facilitate evaluation of injection pressures, flow rates, injection ROI, distribution of amendment, and short- and long-term effectiveness of treatment. Performance monitoring consisting of groundwater sampling was performed at existing and new monitoring wells before, during, and after pilot testing to evaluate remedial progress. The remedial performance of air sparging was evaluated by assessing indicators of dissolved oxygen distribution and longevity in the subsurface, redox parameters including oxidation-reduction potential and ferrous iron, general water quality parameters, and dissolved arsenic removal.

During the ROI test, it was observed that connection between wells was highly variable and treatment was following preferential pathways due to the semi-confined field conditions. Injection of the ferrous iron following the ROI was problematic and the desired concentrations were not achieved due to the iron coming out of the solution as it was being injected. Based on the pilot study results, the following conclusions were made:

- Sufficient ROI for full-scale implementation of pilot tested technology was not achieved.
- Where amendment was delivered, a reasonable reduction in groundwater arsenic concentration was, at least temporarily, achieved.
- Geochemical conditions conducive to oxidative treatment of arsenic were not maintained, likely due to the presence of high organic content in soil at the site, including wood fragments observed in soil borings.
- Overall, lithologic, hydrogeological, and geochemical conditions at the site did not appear to be amenable to the air sparging treatment technology that was pilot tested.

Based on these findings, it was not recommended to further pursue ISCO as a primary means of groundwater treatment for the Highway 99 site.

Section 5

Remedial Action Modifications and Justification

5.1 Summary of Remedial Action Modifications

5.1.1 Core Remediation Area

Based on the unfavorable results from the ISCO pilot study, the remedial approach needed to be modified to better ensure the achievement of the RAOs. The modifications include conducting ISS to a greater extent, most importantly, to include soils within the saturated zone. Implementing ISS in high arsenic concentrations in soils within the saturated zone will effectively create a large “monolith” where groundwater will flow around, rather than through contaminated soil. Furthermore, as was shown in the pilot study, the reagent blend chemically binds the arsenic such that the stabilized soils do not leach arsenic at concentrations greater than the cleanup level.

After removing high arsenic concentration soils from further exposure and release to groundwater, attenuation of arsenic in groundwater will be more effective. The need for implementing groundwater treatment will be evaluated following a period of groundwater monitoring post soil remediation. Currently, ISS is planned to occur during the spring of 2023. Immediately following the ISS, groundwater monitoring will be conducted quarterly on the Highway 99 site. Remediation of the WSDOT P429 Plus property may be implemented in the year 2024. Once remediation of the WSDOT P429 Plus property has been completed and new monitoring wells installed, quarterly monitoring will also include that property and will continue for two more years. At the end of this (up to 5 years) the groundwater data will be evaluated with regard to the progress in achieving groundwater cleanup levels. If this assessment determines that groundwater cleanup levels will likely not be achieved throughout the site, a program of in situ treatment will be initiated. Based on the results of the ISCO pilot study, ISCO is not likely to be the favored in situ groundwater treatment. This RCAP proposes in situ treatment by zero-valent iron (ZVI) injection. Since WSDOT will be removing all soil greater than 20 mg/kg from its property and will conduct dewatering during the excavation, the need for future groundwater treatment is not planned on the P429 Plus property.

The design mix and effectiveness of the ISS was evaluated through completing a geotechnical field investigation, bench scale study, and field pilot study as described in the following sections. The remediation level for treatment of arsenic concentrations in soil (20, 90, 250, and 500 mg/kg), was then determined through development of the DCA as outlined in MTCA. The DCA also considered varying degrees of possible groundwater treatment based on the level of ISS. Groundwater treatment for the 20 mg/kg scenario would not be necessary as ISS would occur essentially throughout the entire parcel. The DCA evaluates which of the alternatives that meet the threshold requirements are permanent to the maximum extent practicable. The DCA for the increased ISS is presented in Section 6.

5.1.2 WSDOT P429 Plus Property

The other major modification to the remedial action is that soil excavation will occur on the adjacent WSDOT P429 Plus property. WSDOT plans to conduct excavation of all soils exceeding

20 mg/kg on the P429 Plus property in conjunction with construction during the SR 167/I-5 to SR 509 – New Expressway Stage 1b project. The WSDOT project includes rerouting Hylebos Creek by moving the present undercrossing about 300 feet south where it will enter into WSDOT's P429 parcel (**Figure 7**). In accordance with an agreement between WSDOT and USGI, WSDOT will also be conducting excavation of the arsenic-contaminated sediment in Hylebos Creek. Since WSDOT's work already impacts Hylebos Creek and the affected sediment, it will be more expedient and cost effective for WSDOT to conduct the sediment cleanup in conjunction with their planned freeway improvements. WSDOT's planned scope of the remediation activities are detailed in the Interim Action Work Plan (IAWP) included as **Appendix A** in this RCAP and summarized as follows:

- Remove contaminated sediment and a limited amount of streambank soil in the existing Hylebos Creek channel (i.e., the scope of work covered in the original CAP).
- Conduct dewatering as necessary to allow for the soil excavation.
- Excavate and dispose of soils containing greater than 20 mg/kg arsenic within the new relocated Hylebos Creek channel, as well as throughout the P429 Plus property.
- Install low permeability soil barriers in the sediment removal and soil excavation areas to prevent recontamination by infiltration of arsenic contaminated groundwater.
- Backfill the remedial excavation, construct the new creek bed, install monitoring wells, and restore the remainder of the property as a riparian buffer.

Figures 12 and 13 show the plan view and cross section views of the anticipated remedial excavations.

5.2 Geotechnical Field Investigation and Bench Scale Treatability Study Results

In 2020-2021, geotechnical field investigation and bench scale treatability studies were conducted at both USGI's Highway 99 (CDM Smith 2021) and Puyallup sites. Remediation of USGI's Puyallup site is on a similar path as the Highway 99 site and the two sites are very similar in the contaminant type and source, transport mechanisms, and hydrogeologic conditions. The purposes of these studies were to provide sufficient physical and analytical data to design and implement an ISS pilot study with the intent of proceeding to full scale implementation onsite. The tasks completed and objectives of each task included:

Geotechnical Investigation - The objective of the geotechnical investigation was to further refine our understanding of subsurface soil conditions and characterize the engineering properties of soils. These data were used to finalize design of the bench scale ISS treatability study, to conduct a constructability evaluation for implementation of the ISS at the site and plan for a pilot study. The feasibility of conducting a single pilot study that would evaluate ISS for both of USG's Highway 99 and Puyallup sites was assessed and determined to be appropriate.

Bench Scale Treatability Study - The objective of this task was to evaluate the physical and analytical properties of various S/S mix designs in an effort to identify an S/S mix design that meets the project performance criteria, which are, as follows:

1. Unconfined Compression Strength (UCS) – The UCS performance criteria greater than or equal to 50 pounds per square inch after a curing period of 28 days.
2. Hydraulic Conductivity – The hydraulic conductivity performance criteria of the bench scale treatability study is less than or equal to 1E-06 centimeters per second Environmental Protection Agency (EPA) (EPA 2009).
3. Leaching and Extraction Tests – The samples were subjected to leaching and extraction tests to assist in determining the amount of arsenic that can leach from S/S treated soils. The S/S test sample that best met UCS and hydraulic conductivity standards was subjected to the synthetic precipitation leaching procedure (SPLP) and semi-dynamic leach (SDL) testing.

The SDL test was run for a 42 day period, at the end of which the arsenic concentration in the test water was 8.7 µg/L. The SDL test data collected over the 42 day test period were used to predict dissolved arsenic concentration at future time periods between one and ten years at the interface between the treated soil and the aqueous phase (surface water). The concentrations for Year 1 through Year 10 were calculated to be less than the practical quantitation limit of (2 to 3.0 µg/L).

Based on the results of these studies, the recommended ISS mix for the Highway 99 site consists of Portland Cement at a dosage rate of 13 percent by weight, bentonite at a dosage of 1 percent by weight, and ferrous sulfate heptahydrate at a mass ratio of about 20:1 to the arsenic concentration, equivalent to a mass ratio of 4:1 iron to arsenic.

Based on the results of the bench scale studies for both the Highway 99 and Puyallup sites, it was deemed appropriate and recommended that only one pilot study be performed to evaluate both sites and that the pilot study would be conducted on the Puyallup site due to the slightly more complex conditions at that site. The field portion of the pilot study was completed on the Puyallup site in the Fall of 2021, the results of which are described in Section 5.3.

5.3 Pilot Study Results

The methods, findings and conclusions of the ISS pilot study completed at the Puyallup site are presented in a report dated February 25, 2022 and summarized in this section (CDM Smith, 2022).

The Puyallup site ISS pilot study consisted of installing five ISS columns using a 3-foot diameter auger to mix soil and reagents throughout the column length. The target depth for each column was 35 ft bgs; however, two of the columns encountered refusal at depths of 31.9 and 32.8 ft bgs. The five columns were installed in two groupings. The first grouping contained three overlapping columns with an admixture dosed to treat soil containing 550 ppm arsenic. The second grouping contained two overlapping columns with an admixture that assumed treatment of soil containing 850 ppm arsenic. This was accomplished by adjusting the amount of ferrous sulfate heptahydrate (FSH) in the admixture. The weights of all other components remained the same.

A premix of sand (10 percent by weight), cement (10 percent by weight), and water was delivered directly to the site in a cement truck from a local ready-mix plant. Once on site, bentonite slurry (2 percent by weight), which was premixed in the on-site batch plant, was

pumped into the cement truck. Lastly, granular FSH was mixed into the cement truck. The final mixture was allowed to fully mix in the cement truck and then pumped to the auger drill rig.

The treatment zone was mixed by advancing the auger at a controlled rate to ensure relatively complete mixing throughout the vertical column. The ISS reagents were added through an injection port located on the auger flights. As the augers advanced, the ISS reagent addition created treated “columns,” each of which overlapped by approximately 10 percent of the column area to create a homogenous treated zone.

ISS quality control sampling was conducted by collecting wet grab samples of the treated material at specified depths, preparing the collected material into cylinders, allowing them to cure and then sending them to a laboratory for geotechnical and analytical testing. The cured samples were tested for the same performance criteria as was done for the bench scale test. The following summarizes the results of this testing:

- UCS was variable; however, the results were considered acceptable because: a) the post-ISS treated soils improved the existing soil strengths at the site, and b) future use of the sites do not require redevelopment.
- Hydraulic conductivity performance criteria were met with the exception of one sample, and in most cases hydraulic conductivities were lower than the target maximum value of 1.0E-06 centimeters per second. This indicates that movement of groundwater through the ISS-mixed soil mass will be greatly reduced post solidification.
- The SDL test met the MTCA Method A cleanup level performance goal of 5 µg/L or less. This was observed for both treatments using both dosing rates of FSH.
- Arsenic concentrations were non-detect in all leachates analyzed by the SPLP method.

Based on the results of this study, the pilot study was deemed successful and the recommended mix design for the Highway 99 site remains unchanged from that of the bench scale study.

Section 6

Disproportionate Cost Analysis

This section presents the results of the DCA. The DCA is used to further evaluate which of the alternatives that meet the threshold requirements are permanent to the maximum extent practicable. During the conceptual design, remediation of soil in the Core Remediation Area containing arsenic concentrations greater than 20, 90, 250, and 500 mg/kg by ISS were calculated using the Leapfrog model described in Section 2.4. These are the remedial alternatives that were subjected to the DCA. The extents of the ISS treatment areas for each of these alternatives are depicted in **Figures 14** through **25**. Note that the ISS treatment area for all remediation scenarios was extended to the P429-Plus property. This was done intentionally to provide an impermeable barrier adjacent to that parcel. This DCA does not include the P429 Plus property as soil containing greater than 20 mg/kg arsenic is being completely removed by excavation and offsite disposal. The option of complete soil removal is allowed without completion of a DCA under MTCA.

Table 6-1 presents a comparison of the treatment soil volumes and mass arsenic treated for each of the potential remedial treatment concentrations. As is seen in **Table 6-1**, over three quarters of the mass of arsenic is treated just by targeting soils that exceed 500 mg/kg arsenic.

Table 6-1 Comparison of Soil Volumes and Arsenic Mass Treated for Each Remedial Treatment Alternative

Alternative	Treatment Concentration	Soil Volume	Mass Arsenic Treated	Percent Arsenic Mass Treated	Incremental Volume Increase (compared to 500 µg/kg)
	(mg/kg)	(cy)	(Pounds)		
1	>20	23,486	1,910	100%	437%
2	>90	7,437	1,792	94%	70%
3	>250	5,083	1,600	84%	16%
4	>500	4,369	1,488	78%	

6.1 Disproportionate Cost Analysis Methodology

The DCA involves comparing the costs and benefits of alternatives and selecting the alternative whose incremental costs are not disproportionate to the incremental benefits. As presented in WAC 173-340-360(3)(f), the evaluation criteria are as follows:

- Protectiveness
- Permanence
- Long-term effectiveness
- Management of short-term risks

- Technical and administrative implementability
- Consideration of public concerns
- Cost

6.1.1 Protectiveness

Each alternative is assessed to determine whether it can provide appropriate protection of human health and the environment from unacceptable risks posed by hazardous substances, pollutants, or contaminants present at the Highway 99 site. Evaluation of this criterion focuses on how site risks are eliminated, reduced, or controlled through containment, removal/disposal, treatment, and/or institutional controls and whether an alternative poses any unacceptable cross-media impacts.

6.1.2 Permanence

MTCA specifies that when selecting a cleanup action alternative, preference shall be given to actions that are "permanent solutions to the maximum extent practicable." Evaluation criteria include the degree to which the alternative permanently reduces the toxicity, mobility or volume of hazardous substances. Factors to be considered, as appropriate, include the following:

- The treatment processes the alternatives use and materials they will treat.
- The amount of hazardous substances, pollutants, or contaminants that will be destroyed or treated, including how the principal threat(s) will be addressed.
- The degree of expected reduction in toxicity, mobility, or volume of the waste due to treatment.
- The degree to which the treatment is irreversible.
- The type and quantity of residuals that will remain following treatment, considering the persistence, toxicity, mobility, and propensity to bioaccumulate such hazardous substances and their constituents.
- Whether the alternative would satisfy the statutory preference for treatment as a principal element of the remedial action.

6.1.3 Long-Term Effectiveness

Long-term effectiveness is a parameter that expresses the degree of certainty that the alternative will be successful in maintaining compliance with cleanup standards over the long-term performance of the cleanup action. MTCA contains a specific preference ranking for different types of technologies that is to be considered as part of the comparative analysis. The ranking places the highest preference on technologies such as reuse/recycling, treatment, immobilization/solidification, and disposal in an engineered, lined, and monitored facility. Lower preference rankings are applied for technologies such as on-site isolation/containment with attendant engineered controls, and institutional controls and monitoring.

6.1.4 Management of Short-Term Risks

This criterion reviews the effects of each alternative during the construction and implementation phase of the remedial action until remedial response objectives are met. The short-term impacts of each alternative are assessed, considering the following factors, as appropriate:

- Short-term risks that might be posed to the community during implementation of an alternative.
- Potential impacts on workers during the remedial action and the effectiveness and reliability of protective measures.
- Potential adverse environmental impacts resulting from construction and implementation of an alternative and the reliability of the available mitigation measures during implementation in preventing or reducing the potential impacts.
- Time until protection is achieved.

6.1.5 Implementability

The technical and administrative feasibility of implementing an alternative and the availability of various services and materials required during its implementation is evaluated under this criterion. The ease or difficulty of implementing each alternative will be assessed by considering the following factors detailed in Exhibit 5-1.

Table 6-2 Implementability Factors to be Considered during Alternative Evaluation

Criterion	Factors to be Considered
Technical feasibility	<ul style="list-style-type: none"> ▪ Technical difficulties and unknowns associated with the construction and operation of a technology ▪ Reliability of the technology, focusing on technical problems that will lead to schedule delays ▪ Ease of undertaking additional remedial actions, including what, if any, future remedial actions would be needed and the difficulty to implement additional remedial actions ▪ Ability to monitor the effectiveness of the remedy, including an evaluation of risks of exposure should monitoring be insufficient to detect a system failure
Administrative feasibility	<ul style="list-style-type: none"> ▪ Activities needed to coordinate with other offices and agencies and the ability and time required to obtain any necessary approvals and permits from other agencies (for offsite actions)
Availability of services and materials	<ul style="list-style-type: none"> ▪ Availability of adequate offsite treatment, storage capacity, and disposal capacity and services ▪ Availability of necessary equipment and specialists and provisions to ensure any necessary additional resources ▪ Availability of services and materials, plus the potential for obtaining competitive bids, which is particularly important for innovative technologies ▪ Availability of prospective technologies

6.1.6 Consideration of Public Concerns

The public involvement process under MTCA is used to identify potential public concerns regarding remedial alternatives. The extent to which an alternative address those concerns is

considered as part of the evaluation process. This includes concerns raised by individuals, community groups, local governments, tribes, federal and state agencies, and other organizations that may have an interest in or knowledge of the site.

6.1.7 Cost

The analysis of remedial action alternative costs under MTCA includes the costs associated with implementing an alternative, such as the pre-design work, design, construction, long-term monitoring and institutional controls. Costs are intended to be comparable among different alternatives to assist in the overall analysis of relative costs and benefits of the alternatives. The costs to implement an alternative include the cost of construction, and the net present value of any long-term costs. Long-term costs include operation and maintenance costs, monitoring costs, equipment replacement costs and the cost of maintaining institutional controls. For the cost estimates for the Highway 99 Site, there are no operation and maintenance or equipment replacement costs because there are no operating systems (such as a pump-and-treat system).

6.1.8 Criteria Priorities and Score Calculations

In the DCA process, each alternative was assigned a rank (score) for each criterion using a scale of 1 to 6 (6 being the best) that represent a judgement of how well an alternative satisfies a criterion. Since each criterion is not considered equal by the Ecology, each rank is multiplied by a weighting factor or percentage representative of the criterion before the ranks are added up to produce a total that is referred to as a “total weighted benefit” and then divided by the relative cost to come up with a relative benefit score to cost ratio (see equation below). These ratios are compared and the higher the ratio the more beneficial the alternative is.

The weighting percentages for the Highway 99 Site, as accepted by Ecology, are summarized below:

- Protectiveness - 30%
- Permanence - 20%
- Long-term effectiveness - 20%
- Management of short-term risks - 10%
- Technical and administrative implementability - 10%
- Consideration of public concerns - 10%

After each criterion is assigned a value between 1 and 6 and appropriately weighted using the factors above the overall relative benefit score ratio is calculated as follows:

$$\text{RBSR} = 1000 * ((\text{Prot} * 0.3) + (\text{Perm} * 0.2) + (\text{LTE} * 0.2) + (\text{STR} * 0.1) + (\text{Imp} * 0.1) + (\text{PC} * 0.1)) / C$$

Where,

RBSR = Relative benefit score ratio

Prot = Protectiveness score (1 through 6)

Perm	=	Permanence score (1 through 6)
LTE	=	Long-term effectiveness score (1 through 6)
STR	=	Management of short-term risks score (1 through 6)
Imp	=	Technical and administrative implementability score (1 through 6)
PC	=	Consideration of public concerns score (1 through 6)
C	=	Cost in millions

A remedy cost in the millions generally results in an RBSR on the order of hundreds, allowing differences between alternatives to be easily discerned.

6.2 MTCA Disproportionate Cost Analysis

The following sections provide a discussion regarding differences between the alternatives for each of the evaluation criteria in the DCA. The scoring for each alternative is then presented, based on this evaluation. The scoring of the benefit of each metric for each remedial alternative is somewhat subjective and based on professional judgement.

Note that the evaluation does not include discussion of the arsenic soil removal on the WSDOT property or the contaminated sediment in Hylebos Creek because those actions are the same for each of the alternatives evaluated and include a full removal action.

6.2.1 Overall Protectiveness

Soil: All of the alternatives will require institutional controls and maintenance of the asphalt/soil cover because contaminated soil is stabilized, not removed. Given the commercial nature of the site, whereby the existing asphalt cover is maintained to allow for the day-to-day business activities, there is virtually no risk of exposure to site soils on a day-to-day basis. Actions that would breach the existing cover, such as to repair underground utilities or redevelopment would be rare. The alternatives obviously differ in how much soil is stabilized; however, arsenic concentrations exceeding 20 mg/kg within the first five feet occurs infrequently, further lessening the potential for exposure even for activities such as underground repair work. A restrictive covenant and contaminated materials management plan implemented as part of the institutional controls (see Section 7.9.2) will provide further protections from exposure to arsenic in soil. Therefore, none of the alternatives have a strongly greater or lesser overall protection for human health and the environment with regard to soil exposure.

Groundwater: If it is determined that no further active groundwater treatment is needed then groundwater cleanup levels would be realized sooner for Alternative 1 than for Alternatives 2 through 4; Alternative 2 than for Alternatives 3 and 4, and so forth. If further groundwater treatment is needed, then groundwater cleanup levels may be achieved in a similar timeframe for alternatives 2 through 4.

Based on these considerations in total, Alternatives 1, 2, 3, and 4 were scored respectively, as follows: 5.5, 5, 4.5, 4.

6.2.2 Permanence

ISS is considered a permanent technology. As greater quantities of affected soil are stabilized and solidified, there is less arsenic that might leach into groundwater. The alternatives with larger amount of treated soil (with Alternative 1 treating the largest amount) provide more permanence. Natural attenuation of arsenic in groundwater in areas not treated by ISS occurs at the site mainly via precipitation reactions which can occur indefinitely compared to adsorption processes, which are limited by the available adsorption sites within the aquifer. The majority of arsenic will be tied up via ISS for all of the technologies, so theoretically all of the technologies should be suitable in achieving a permanent cleanup. Regardless, due to the greater amount of arsenic that would be treated by ISS and considering the percentages of arsenic treated, MNA would occur faster sequentially in the order of Alternatives 1, 2, 3, 4. As is indicated previously, in situ treatment of groundwater using ZVI will be initiated should the initial groundwater data indicate that additional treatment beyond ISS is needed to achieve the cleanup level. While the chemistry of treatment of arsenic by ZVI is not well understood, adsorption followed by co-precipitation is considered an important pathway to removing arsenic by ZVI. With sufficient treatment throughout the residual arsenic plume, this should be considered a permanent technology.

Based on these considerations, Alternatives 1, 2, 3, and 4 were scored respectively, as follows: 6, 5.5, 5, 3.5.

6.2.3 Long-Term Effectiveness

Again, ISS is considered a permanent technology and the degree of treatment necessary to immobilize the arsenic in soil via ISS to achieve the groundwater cleanup level for arsenic in a reasonable time frame cannot be fully predicted. For this reason, in situ groundwater treatment using ZVI was added as a secondary treatment method. The extent of groundwater treatment would vary, based on the volume of soil treated by ISS.

Based on these considerations, Alternatives 1, 2, 3, and 4 were scored respectively, as follows: 6, 5.5, 5, 3.5.

6.2.4 Management of Short-Term Risks

Alternatives 1 through 4 all have risks associated with work around heavy equipment. Alternatives 2 through 4 require excavation and temporary stockpiling of soil, then replacement in the excavation. Alternatives 1 and 2 will require offsite soil disposal of excess soil, while Alternatives 3 and 4 may not. Site work will require work under a health and safety plan, which will address appropriate personal protective equipment, best management practices, training, cordoning off construction areas, and other appropriate protective measures to manage risks.

Based on these considerations in total, Alternatives 1, 2, 3, and 4 were scored respectively, as follows: 3, 3.5, 4, 4.

6.2.5 Technical and Administrative Implementability

Technical Implementability

All of the alternatives are technically implementable. However, as the area of ISS is increased, so will the difficulty in implementing the alternative. Alternatively, the greater the area for treatment by ZVI, if implemented, so would be the difficulty of implementability.

Administrative and regulatory requirements

Substantive requirements for a grading permit would need to be met for each of the alternatives. Each of the alternatives would likely require an Underground Injection Control (UIC) permit.

Site access for construction and monitoring

It is presently expected that WSDOT would allow access onto its parcel for staging. If this were to turn out to not be the case, then the logistics of staging onsite would be increasingly difficult and time consuming as the area of ISS is increased.

Integration with existing site operations or other potential future remedial action

There are presently no operations onsite or on the adjacent WSDOT parcel. As long as the remedial action occurs before WSDOT begins its remedial action, none of the alternatives require integration with site operations and future remedial actions; therefore, there would be no substantive difference between the different alternatives.

Based on these considerations in total, Alternatives 1, 2, 3, and 4 were scored, respectively, as follows: 4, 4, 4.5, 5.

6.2.6 Consideration of Public Concerns

The RI/FS and CAP went out to public comment in July-August 2015. Ecology addressed these comments without further challenge. Additional public concerns will be considered and addressed following the comment period for the RCAP when the public's specific concerns become known. However, it is expected that the public will not have concerns that are any more challenging to address than previously. Furthermore, based on the prior comments received, it is anticipated that the public's comments will be more general in nature, rather than specific to the alternatives.

Based on the anticipated expectations of the public, Alternatives 1, 2, 3, and 4 were scored equally.

6.2.7 Costs

Cost estimates were developed for each Alternative in accordance with "A Guide to Developing and Documenting Cost Estimates during the Feasibility Study" (EPA 2000). For this site, cost estimates were available based on the accompanying Puyallup Pilot Study conducted in 2021 and were supported by estimates from the ISS contractor. Other unit costs were developed based on local experience with excavation, transport/disposal, and paving.

Types of costs that were assessed for each alternative include: capital costs, annual O&M costs, periodic costs, and present value of capital and annual O&M costs. Each of these cost types are described further below.

- Capital costs are expenditures that are required to construct a remedial action. They are exclusive of costs required to operate or maintain the action throughout its lifetime. Capital costs consist primarily of expenditures initially incurred to build or install the remedial action. Capital costs include all labor, equipment, and material costs (including contractor markups, such as overhead and profit) associated with activities, such as mobilization/demobilization, site work, excavation and disposal of contaminated soil, and groundwater remediation. Capital costs also include expenditures for professional/technical services that are necessary to support construction of the remedial action.
- For the USGI Highway 99 site cost estimate, the capital costs include the professional services and plans to develop the Engineering Design Report and other plans and to manage the remediation project; the site preparation, remediation, and restoration services; costs to remove and replace groundwater monitoring wells; and the indirect costs such as permits, insurance, bonding, and taxes.
- Annual O&M costs are post-construction costs necessary to ensure or verify the continued effectiveness of a remedial action. These costs are estimated mostly on an annual basis. Annual O&M costs include all labor, equipment, and material costs (including contractor markups, such as overhead and profit) associated with activities, such as monitoring. Annual O&M costs also include expenditures for professional/technical services necessary to support O&M activities.
- Annual O&M costs for this project are modest, consisting largely of the expectation for quarterly groundwater monitoring for the first 5 years after remediation. If it is determined the trends of arsenic concentrations in the groundwater are reducing at a sufficient rate to achieve cleanup levels within a reasonable restoration timeframe, then monitoring intervals may be reduced to every 18 months with Ecology approval to capture the groundwater highs and lows. There are no active remediation systems (such as a groundwater pump and treat system) that require ongoing operation and maintenance.
- Periodic costs are costs that occur only once every few years (e.g., 5-year reviews). These costs may be either capital or O&M costs, but because of their periodic nature, it is more practical to consider them separately from other capital or O&M costs in the estimating process.
- Preparation, review, and filing of an Environmental Covenant was one periodic cost that was identified as occurring in the first year following remediation. Support of 5-year reviews will be addressed by supplying annual groundwater monitoring reports.
- The present value of each alternative provides the basis for the cost comparison. The present value cost represents the amount of money that, if invested in the initial year of the remedial action at a given rate, would provide the funds required to make future payments to cover all costs associated with the remedial action over its planned life. Future O&M and periodic costs are included. Future costs are presented as present values by applying an appropriate discount rate (7 percent) as outlined in A Guide to Developing and Documenting Cost Estimates during the Feasibility Study (EPA 2000).

- Per the guidance, the present value analysis was performed on remedial alternatives using a 7 percent discount (interest) rate over the period of evaluation for each alternative. Inflation and depreciation were not considered in preparing the present value costs.

The cost development for each alternative is provided in **Appendix B**. The cost estimate includes a sheet that lists the estimated remediation volumes (such as cubic yards treated) used in developing the cost estimates for each alternative. Each alternative includes an individual sheet with a breakdown of the estimate for studies (engineering, reports, project management etc.) and construction during the ISS. Another sheet provides an estimate of costs for long-term monitoring following implementation ISS, to include quarterly monitoring for the first five years and annually thereafter. The final sheet provides a rollup estimate of long-term monitoring under each alternative with the estimated timelines of long-term monitoring for Alternatives 1 through 4 at 10, 15, 20, and 30 years respectively. This last sheet also provides the Net Present Value analysis. The levels of detail employed in making these estimates are conceptual but are considered appropriate for making choices between alternatives.

The information provided in the cost estimate is based on the best available information regarding the anticipated scope of the remedial alternatives. Unit costs were derived using construction cost estimates solicited from applicable vendors and contractors; review of actual costs incurred during similar applicable projects, such as the Puyallup Pilot Study; and professional judgment. The duration of the long-term monitoring was adjusted based on the level of treatment in Alternatives 1 through 4. For Alternative 1, in which the most soil is stabilized/solidified, the estimated duration of groundwater monitoring is 10 years; for Alternative 2, 15 years; for Alternative 3, 20 years; and for Alternative 4, 30 years.

Table 6-3 provides a summary of the cost estimates developed for Alternatives 1 through 4. A percentage contingency was applied to each of the activities. Contingencies were based on the perceived uncertainties of the activities. For example, higher contingency was applied to remediation activities such as stabilization/solidification due to its development as a relatively new technology, whereas less contingency is applied to better understood costs such as asphalt paving. The percentages used for contingency and professional/technical services costs are based on guidance from Section 5.0 of "A Guide to Developing and Documenting Cost Estimates During the Feasibility Study," (EPA 2000). The contingency percentages for each activity ranged from 10 to 25 percent with an overall project contingency of 16 percent.

Table 6-3 Summary of Remedial Cost Estimates by Alternative

Alternative	Capital Cost	Present Value of ZVI Treatment	Present Value of Long-Term Monitoring	Total Net Present Value
1 - 20 ppm	\$6,670,000	\$0	\$96,400	\$6,766,000
2 - 90 ppm	\$3,720,000	\$307,000	\$142,000	\$4,169,000
3 - 250 ppm	\$3,000,000	\$397,000	\$158,000	\$3,555,000
4 - 500 ppm	\$2,590,000	\$487,000	\$177,000	\$3,254,000

6.2.8 Results of the DCA

Based on the rankings for each alternative discussed in Sections 6.2.1 through 6.2.6, the total weighted benefit scores for Alternatives 1 through 4 were 5.3, 5.0, 4.7, and 4.0, respectively as shown on **Table 6-4**. Calculating in the cost for each alternative, the RBSR for each alternative is shown on **Table 6-4** and summarized as follows:

Alternative 1 - 776

Alternative 2 - 1187

Alternative 3 - 1322

Alternative 4 - 1229

The RBSR for Alternatives 2 through 4 are significantly greater than Alternative 1 (about 52% to 70%). The RBSR for Alternative 3 is about 7% greater than Alternative 4 and about 11% greater than for Alternative 2. All in all, the RBSR for Alternative 3 is significantly greater than for Alternative 1 and slightly greater than for Alternatives 2 and 4.

Table 6-4 Disproportionate Cost Analysis

Alternative	Description ¹	Disproportionate Cost Analysis Criteria ²									
		Protectiveness	Permanence	Long-Term Effectiveness	Management of Short-Term Risks	Technical and Administrative Implementability	Consideration of Public Concerns	Total Weighed Benefit	Cost (millions)	Relative Benefit Score Ratio (RBSR)	Overall Recommendation
	Weighting Criteria	30%	20%	20%	10%	10%	10%				
1	ISS all soil greater than 20 mg/kg	5.5	6	6	3	4	5	5.3	6.8	776	No
2	ISS all soil greater than 90 mg/kg	5	5.5	5.5	3.5	4	5	5.0	4.2	1187	No
3	ISS all soil greater than 250 mg/kg	4.5	5	5	4	4.5	5	4.7	3.6	1322	Yes
4	ISS all soil greater than 500 mg/kg	4	3.5	3.5	4	5	5	4.0	3.3	1229	No

Notes:

1) All of the alternatives will include the following: Removal of arsenic contaminated sediment in Hylebos Creek, excavation and offsite disposal of arsenic contaminated soil on the adjacent WSDOT P429 Plus property, Institutional Controls, O&M, and Monitoring.

2) Disproportionate Cost Analysis Criteria Scoring:

- 6 Ideal/Excellent Favorability
- 5 High Benefit/Very Favorable
- 4 Reasonable Benefit/Favorable
- 3 Some Benefit/Moderate Favorability
- 2 Slight Benefit/Low Favorability
- 1 Virtually No Benefit/Not Favorable

Section 7

Recommended Remedial Alternative

7.1 ISS Conceptual Design

Based on the results of the DCA, Alternative 3 is the recommended alternative. The conceptual design for Alternative 3, treatment of all soils that exceed 250 mg/kg, is shown on **Figures 20** through **22**. At a minimum, the treatment area will be split up into four sub-areas to optimize the depths of treatment. **Table 7-1** presents the physical data for each of these treatment sub-areas including volume, top and bottom of treatment zone, and treatment zone thickness as proposed during the conceptual design. As is shown on **Figure 21** and indicated in **Table 7-1**, the top five feet of soils will be excavated and temporarily stockpiled onsite. These are the clean soils that were used as backfill during the initial remedial action. Once these soils have been excavated, mass stabilization by ISS treatment will commence using an excavator to place and mix in the admixture. The treatment area will be divided into multiple “cells” and the excavator will complete work in one cell before moving to another. After completing the ISS, the temporarily stockpiled soil will be used to backfill the remainder of the excavation. Excess soil is anticipated some of which will be used to nominally increase the site grade slightly; the remainder will be disposed of offsite.

Table 7-1 Summary of Proposed ISS Treatment Areas and Volumes^a

Area ID	Average Ground Surface	Pre-Excavation Depth	Bottom of Treatment Zone		Treated Area Thickness	Approximate Volume
	(EL) ^b	(ft bgs)	(EL) ^b	(ft bgs)	(ft)	(cy)
250-1	22	5	5	17	12	2,800
250-2	23	5	7	16	11	2,300
250-3	23	--	3	20	4	10
250-4	23	5	8	15	10	25
Total	--	--	--	--	--	5,135

Notes:

cy – cubic yards

ft – feet

EL – elevation.

ft bgs – feet below ground surface

(a) Volume of impacted soils are interpreted based on available analytical data and 3D interpolated volumes.

(b) Elevations referenced are based on the North American Vertical Datum of 1988 (NAVD 88).

A summary of the total percentages of soil treated by ISS that exceeds concentrations of 20, 90, 250, and 500 mg/kg arsenic under remedial Alternative 3 is summarize in **Table 7-2**. Based on this scenario, approximately 100 percent of site soils exceeding 250 mg/kg, about 85% of soils exceeding 90 mg/kg, and 35% of soils exceeding 20 mg/kg will be treated within the core remediation area.

Table 7-2 Summary of Arsenic Concentrations Treated Using a Cleanup Criteria that Targets >250 mg/kg in the Core Remediation Area

Arsenic Exceedance Criteria	Impacted Soil Volume ^a	Proposed Treated Soil Volume	
		Volume	Percent Treated
(mg/kg)	(cy)	(cy)	
>20	8,105	2,836	35.0%
>90	1,397	1,190	85.1%
>250	470	470	100%
>500	242	242	100%

Notes:

(a) Volume of impacted soils are interpreted based on available analytical data and 3D interpolated volumes. Note that impacted soil volumes are different than the treatment volumes in Table 6-1. This is because the impacted soil volumes are based upon the model. The modeled areas cannot be precisely excised out for treatment using heavy equipment and is therefore larger. Also, the remediation area was extended to the Southern property boundary.

7.2 P429 Plus Property Conceptual Design

Due to the planned highway improvements, WSDOT will excavate all soil exceeding the MTCA Method A cleanup level of 20 mg/kg arsenic on the P429 Plus property. In September 2021, an IAWP was completed, which details the scope of the Hylebos Creek contaminated sediment removal and soil excavation on the P429 Plus property. A copy of this IAWP is attached as **Appendix A**. The approximate remedial excavation areas are shown on **Figures 12** and **13**. The IAWP describes the proposed remedial methodology and includes figures that outline the anticipated areas of excavation.

7.3 Applicable Laws and Regulations

Applicable laws and regulations provide the framework for the cleanup action. WAC 173-340-360(2) and 173-340-710(1)(a) require that cleanup actions conducted under MTCA comply with applicable federal and state laws. Applicable laws are defined as those requirements that are legally applicable, as well as those that Ecology determines to be both relevant and appropriate.

Remedial actions conducted under a consent decree or agreed order with Ecology and the Attorney General's office must comply with the ARARs, but are exempt from their procedural requirements, such as permitting and approval requirements (WAC 173-340-710(9)). The exemption is not applicable if Ecology determines that the exemption would result in the loss of approval from a federal agency that may be necessary for the state to administer any federal law.

The applicable laws and regulations for the cleanup action will likely include the following:

7.3.1 Federal ARARs

- The Clean Water Act (33 USC 1251 et seq.)
- National Toxics Rule (40 CFR 131.36 et seq.)

- Comprehensive Environmental Response, Compensation, and Liability Act of 1980 (42 USC 9601 et seq. and 40 CFR 300)
- Resources Conservation and Recovery Act (40 CFR Part 261 through 265, 268, 270, and 271)
- Endangered Species Act (16 USC § 1531 et seq.)
- Native American Graves Protection and Repatriation Act (25 USC 3001 through 3113; 43 CFR Part 10)
- Archaeological Resources Protection Act (16 USC 470aa et seq.; 43 CFR Part 7)
- National Historic Preservation Act (16 USC 470 et seq.; 36 CFR Parts 60, 63, and 800)

7.3.2 Washington State ARARs

- MTCA (Revised Code of Washington [RCW] 70.A.305)
- MTCA Cleanup Regulations (WAC 173-340)
- Sediment Management Standards (WAC 173-204)
- Washington State Environmental Policy Act (RCW 43.21)
- Water Quality Standards for Washington Surface Waters (Chapter 173 201A WAC)
- Washington State Shoreline Management Act (RCW 90.58, Chapter 173 18 WAC, Chapter 173-22 WAC, and Chapter 173-27 WAC)
- Washington Underground Injection Control Program (Chapter 173-218 WAC)
- Washington State Hydraulics Projects Approval (RCW 77.55; Chapter 220-110 WAC)
- Washington Dangerous Waste Regulations (Chapter 173-303 WAC)
- Washington's Indian Graves and Records Law (RCW 27.44); Archaeological Site Assessment Requirements (RCW 27.44 and 27.53)
- State of Washington Worker Safety Regulations

7.4 Remnant Contamination Left Onsite

The remedy for the site contains, rather than removes, arsenic. MTCA (WAC 173-340-380(1)(a)(ix)) requires that “the type, level, and amount of hazardous substances remaining on site and the measures that will be taken to prevent the migration of those substances” be specified.

Information about the concentration and volume of contaminants at the site are summarized in the Remedial Investigation (RI) Report (CDM Smith 2016a) and CDR (CDM Smith 2020a). The current version of the Leapfrog model contains all soil data collected to date, including that which

was collected during the more recent geotechnical study, which occurred after the CDR (CDM Smith 2021). Based on modelling, approximately 10,214 cy of soil are impacted by arsenic at concentrations greater than 20 mg/kg throughout the core remediation area on the Highway 99 site. This leaves approximately 5,477 cy of soil that exceed 20 mg/kg that would not be included within the ISS treatment area. WSDOT proposes to remove all soils greater than 20 mg/kg on its P429 Plus property.

With the exception of the soil removed from the WSDOT Plus property, the overall mass of arsenic in site soil will not to be significantly reduced by the cleanup action. However, the ISS will bind up high concentrations of arsenic in what were once saturated soils, thus having an immediate impact on groundwater. Over time, the ISS will serve to reduce arsenic concentrations in groundwater outside the area of ISS with the intent of meeting, at a minimum, the MTCA Method A cleanup level of 8 µg/L for arsenic at the conditional point of compliance.

ISS is a containment remedy and therefore includes institutional controls. Institutional controls that would be applied at the site include land use controls to protect the integrity of the remedy (e.g., not being excavated into) and groundwater use restrictions. An environmental covenant would be instituted on the affected properties. The environmental covenant would be filed with Pierce County.

7.5 Schedule for Implementation

Implementation of the RCAP will be initiated after it is finalized. There are several steps that need to be completed prior to initiation of the full-scale site work. These include completion of an engineering design report (EDR) (Section 7.7.1) and Compliance Monitoring Plan (CMP, Section 7.8); and final approval by Ecology. The projected schedule is therefore dependent upon the time required to finalize the RCAP, complete the public review and comment period, review and approve the EDR, and coordinate the work.

Cleanup actions will be implemented in two phases as follows:

- **Phase 1 – ISS Implementation:** Implementation of the full scale ISS.
- **Phase 2 – WSDOT Remedial Action:** Implementation of the soil excavation on the P429 Plus property, plus the sediment excavation.

The ISS is anticipated to commence in the spring or summer of 2023, but could be implemented at any time of the year. The WSDOT remedial action will occur in conjunction with WSDOT's construction project, likely in 2024. In water work in Hylebos Creek will occur between July 15 and August 31, in the year which this work is conducted, consistent with the Endangered Species Act. Regardless, the ISS and WSDOT's work will need to be coordinated such that there is no interference between the two.

7.6 Restoration Time Frame

Restoration time frame is defined in MTCA as “the period of time needed to achieve the required cleanup levels at the point of compliance established at the site.”

The ISS will provide an immediate benefit by:

1. reducing the potential for direct exposure to arsenic-impacted soil;
2. binding up high arsenic concentrations in vadose soils, which in turn reduces the potential for continued leaching to groundwater; and
3. binding up arsenic in what were once saturated soils, thus having an immediate impact on the reduction of arsenic concentrations in groundwater and continued leaching to groundwater.

Soil excavation on the P429 Plus property will have an immediate benefit as all arsenic-impacted soil above the cleanup level of 20 mg/kg will be removed.

Regardless of the remedial actions taken, residual arsenic will remain in groundwater at concentrations exceeding the 8 µg/L cleanup level following the completion of ISS and soil excavation for some period of time; complete remediation of groundwater will rely on the process of natural attenuation; groundwater treatment will be implemented if it is determined through the initial groundwater monitoring that arsenic concentrations will not meet the cleanup level within 20 years. This is considered compliant with WAC 173-340-360(4) for the following reasons:

- a. Potential risk to human health and the environment is minimal as any residual soil contamination will be capped and groundwater is not withdrawn for any use (e.g., potable or agricultural).
- b. Other than WSDOT's changes, site use will remain the same.
- c. In this instance, a longer restoration time-frame is considered acceptable to achieve the groundwater cleanup level because the selected cleanup action will have a greater degree of long-term effectiveness than ISCO would have.
- d. Natural attenuation processes for arsenic in groundwater following soil removal has been successfully demonstrated at the former USG plant site where the arsenic-impacted fill was derived.
- e. A compliance monitoring program will be implemented. Should at any time during long-term monitoring a determination is made that arsenic concentrations are not attenuating as expected, the need for additional remedial actions will be evaluated and implemented, if necessary.

7.7 Engineering Design/Plans and Specifications

The data from the Puyallup pilot study will be used to develop the full scale design for the Highway 99 site ISS. USGI will prepare engineering design/plans and specifications as described in the following sections. WSDOT's Design-Builder will prepare the plans and specifications for work on the P429 Plus property as described in the IAWP.

7.7.1 Engineering Design Report

An EDR will include sufficient information to develop and review construction plans and specifications and document engineering concepts and criteria used to design the cleanup action. The information required under WAC 173-340-400(4)(a)(i) through 173-340-400(4)(a)(xx) will be included in the EDR.

7.7.2 Construction Plans and Specifications

The Construction Plans and Specifications will detail the cleanup action to be performed. As required by WAC 173-340-400(4)(b), the documents will include the following information, as applicable:

- A description of the work to be performed and a summary of the engineering design criteria from the EDR.
- A site location map and a map of existing conditions.
- A copy of applicable permit applications and approvals.
- Detailed plans, procedures, and specifications necessary for the cleanup action.
- Specific quality control tests to be performed to document the construction, including specifications for testing or reference to specific testing methods, frequency of testing, acceptable results, and other documentation methods.
- Provisions to ensure that the health and safety requirements of WAC 173-340-810 are met.

All aspects of construction will be performed and documented in accordance with WAC 173-340-400(6). These aspects include approval of all of the plans listed above prior to commencement of work, oversight of construction by a Professional Engineer licensed in the State of Washington, and submittal of a Construction Completion Report that documents all aspects of the cleanup and includes an opinion of the engineer as to whether the cleanup was conducted in substantial compliance with the CAP, the EDR, and the construction plans and specifications.

7.8 Compliance Monitoring

The CMP, prepared in accordance with WAC 173-340-410, will describe monitoring to be performed during the cleanup action and includes protection, performance, and confirmational monitoring as described in the following sections. It will also include a Sampling and Analysis Plan (SAP) prepared in accordance with WAC 173-340-820 that will specify the procedures to be followed to ensure that sample collection, handling, and analysis will result in data of sufficient quality to plan and evaluate the cleanup action at the site. The SAP will include the purpose and objective of data collection, rationale for the sampling approach, and responsibilities for sampling and analysis activities. The SAP will describe specifications for sample identifiers; type, number, and location of the samples to be collected; analyses to be performed; documentation of samples; sample containers, collection, and handling; and sampling schedule.

WSDOT's Design-Builder will prepare CMPs for work on the P429 Plus property as described in the IAWP and USGI will prepare CMPs for the ISS work in the core remediation area.

7.8.1 Protection Monitoring

Protection monitoring of soil, sediment, groundwater, and surface water quality will be conducted during the cleanup action to confirm that human health and the environment are protected. The frequency, scope, and duration of monitoring and sampling will be detailed in the CMP. Monitoring will be conducted to ensure workers are protected during the cleanup action.

Examples of protection monitoring include, but are not limited to:

- Dust and erosion controls during implementation of the ISS and soil excavation.
- Equipment decontamination.
- Field screening of arsenic and lead concentrations in soil during soil/sediment excavation.

7.8.2 Performance Monitoring

Performance monitoring is conducted to confirm that the remedial action has attained cleanup standards and remediation levels. Arsenic concentrations in soil (P429 Plus property) and creek bed sediment will be field screened using an X-ray fluorescence device (XRF) device as excavation proceeds. Sediment and soil samples will be collected at the final excavation limits and submitted for laboratory analysis to confirm that the target cleanup levels have been met. A SAP will be developed and submitted to Ecology with the CMP (WAC 173-340-410(2)) for review and approval during the implementation of the remedial action. The plan will specify the soil/sediment samples to be collected, the handling of the samples, and the analysis procedures to be performed per WAC 173-340-820. The CMP will also include requirements for sediment data analysis and evaluation procedures to demonstrate and confirm compliance.

Performance monitoring also includes construction quality control measurements that will be specified in the remedial design for the ISS. Quality control testing will be conducted to assure that the objectives of the S/S are being met. Examples include UCS and permeability testing to confirm that the performance standards are being met.

7.8.3 Confirmational Monitoring

Confirmational monitoring is conducted to confirm the long-term effectiveness of the remedial action and integrity of the engineering controls (Section 7.9.1). Confirmational monitoring requirements will be defined in the CMP, but at a minimum will include requirements, methods, and schedules for the following:

- Inspection of the integrity of the cap over the surface of the site.
- Inspection of the low permeability soil barrier in the Hylebos Creek bed.
- Long-term groundwater monitoring.

Groundwater Monitoring

The purpose of a groundwater quality monitoring program is to verify that arsenic concentrations in groundwater are declining. Groundwater quality monitoring will be conducted as part of the confirmation monitoring per WAC 173-340-410(1)(c) to ensure the remedy is performing as intended, as well as the long-term effectiveness of the remedy. A groundwater quality SAP will be developed and submitted to Ecology (WAC 173-340-410(2)) for review and approval. The plan will specify the groundwater samples to be collected, the handling of the samples, and the analysis procedures to be performed per WAC 173-340-820. The SAP will also include requirements for groundwater data analysis and evaluation procedures to demonstrate and confirm compliance.

Adaptive Management and Contingency Measures

The CMP will include contingency measures, typically implemented in an adaptive management approach, should groundwater monitoring indicate that the cleanup levels are not being met. Groundwater data at the end of the initial 5-year period of quarterly groundwater monitoring will be evaluated and a recommendation will be made as to whether further groundwater treatment should be implemented. Further evaluations will be conducted at the end of each subsequent 5-year review period and contingency measures, such as additional groundwater treatment or soil stabilization would be implemented, if necessary.

7.9 Engineering/Institutional Controls

7.9.1 Engineering Controls

During implementation of the cleanup actions, interim engineering controls will be required. At a minimum, these will include:

- Construction fencing to keep unauthorized personnel out of the work area thereby minimizing exposure to contaminated soil and away from heavy equipment.
- Siltation fencing and/or straw wattles for erosion control.
- Creek diversion during the sediment removal.
- Dust control

Following implementation of the ISS, engineering controls will include replacement of the asphalt pavement over the site and ongoing monitoring and maintenance of the surface cap. The primary purpose of the cap at the site is to mitigate risk of direct human contact with affected soils that exceed MTCA Method A unconditional land use soil cleanup levels that may remain onsite. The cap will not be designed to minimize infiltration; it is not considered necessary.

Following implementation of the sediment cleanup, a low permeability soil barrier will be installed over the excavation area to prevent recontamination of these areas by infiltration of residual arsenic contaminated groundwater during the period of monitored natural attenuation.

7.9.2 Institutional Controls

The cleanup action will incorporate institutional controls. Institutional controls, in this case a restrictive environmental covenant, are measures undertaken to limit or prohibit activities that interfere with the integrity of a remedy or that might result in exposure to hazardous substances at a site. A restrictive environmental covenant will be recorded for the site, that will, at a minimum:

- Restrict activities that may impact or interfere with the remedial action(s) and any monitoring wells.
- Restrict any activities that may threaten continued protection of human health and environment.
- Restrict land use.
- Prohibit groundwater extraction for any water supply purpose.
- Require adherence to a contaminated materials management plan for future activities that would result in soil disturbance.

Where institutional controls are required, Ecology will conduct five-year reviews to evaluate whether human health and environment are being protected, including review of groundwater use and groundwater and cap monitoring results.

7.10 Operation and Maintenance Expectations

Operation and maintenance of the selected remedial alternative will be low. There will be no active systems, so there will be no operations to oversee. The area impacted by ISS will be repaved for future continued commercial use. The area impacted by the soil excavation of the P429 Plus property will be converted to the relocated Hylebos creek channel and the remainder will have vegetation established for use as a riparian corridor. The area impacted by sediment removal will be stabilized and revegetated for continued use as a seasonal creek for any water that may discharge from the upstream wetland.

7.11 Public Participation

Members of the public will be invited to review and comment of the draft RCAP prior to finalization during a formal public comment period. Comments received by Ecology during this period will be entered into the site's record, considered by Ecology, and responded to in a responsiveness summary before the RCAP has been finalized.

Notice for this comment period will include mailings to nearby businesses and residents, email notification distributed to an email listserv, posting in Ecology's Site Register, website updates, and a newspaper legal ad. Contingent on public interest, Ecology will hold a public meeting where detailed information about the site and the draft RCAP will be available.

Section 8

References

Anderson, M.P., and Woessner, W.W. 1992. *Applied Groundwater Modeling – Simulation of Flow and Advective Transport*. San Diego: Academic Press, Inc.

CDM Smith Inc. 2016a. *Remedial Investigation Report, USG Interiors Highway 99 Site, Milton, Washington*. June 23, 2016.

CDM Smith Inc. 2016b. *Feasibility Study, USG Interiors Highway 99 Site, Milton, Washington*. June 23, 2016.

CDM Smith Inc. 2018. *Hot-Spot Characterization and Bench-Scale Testing, USG Interiors Highway 99 Site, 7110 Pacific Highway East, Milton, WA 98354*. March 23, 2018.

CDM Smith. 2020a. *Conceptual Design Report, USG Interiors Highway 99 Site, Milton, Washington*. April 16, 2020.

CDM Smith. 2020b. *Field Pilot Study Evaluation Report, USG Interiors Highway 99 Site, 7110 Pacific Highway East, Milton Washington 983354*. June 12, 2020.

CDM Smith. 2021. *Geotechnical Field Investigation and Bench Scale Treatability Study, USG Interiors Highway 99 Site, Milton, Washington*. August 11, 2021.

CDM Smith. 2022. *Data Summary Report, In Situ Solidification and Stabilization Pilot Study. USG Interiors Puyallup Site, Puyallup, Washington*. February 25, 2022.

Ecology. 1986. *Memorandum to the Project File*. By Dominick Reale, Washington State Department of Ecology. June 30, 1986.

Environmental Protection Agency (EPA). 2000. *A Guide to Developing and Documenting Cost Estimates During the Feasibility Study*. EPA 540-R-00-002. OSWER 9355.0-75. July.

Hazen. 1911. *Discussion—Dams on sand foundations*. Transactions, American Society of Civil Engineers, v. 73, p. 199.

Ecology. 2016. *Cleanup Action Plan (CAP), USG Interiors Highway 99 Site, Milton, Washington*. Issued by Washington State Department of Ecology. June 23, 2016.

Environmental Protection Agency (EPA), Office of Research and Development, et al. 2009. *Technology Performance Review: Selecting and Using Solidification/Stabilization Treatment for Site Remediation*. Publication No. EPA/600/R-09/148.

Figures

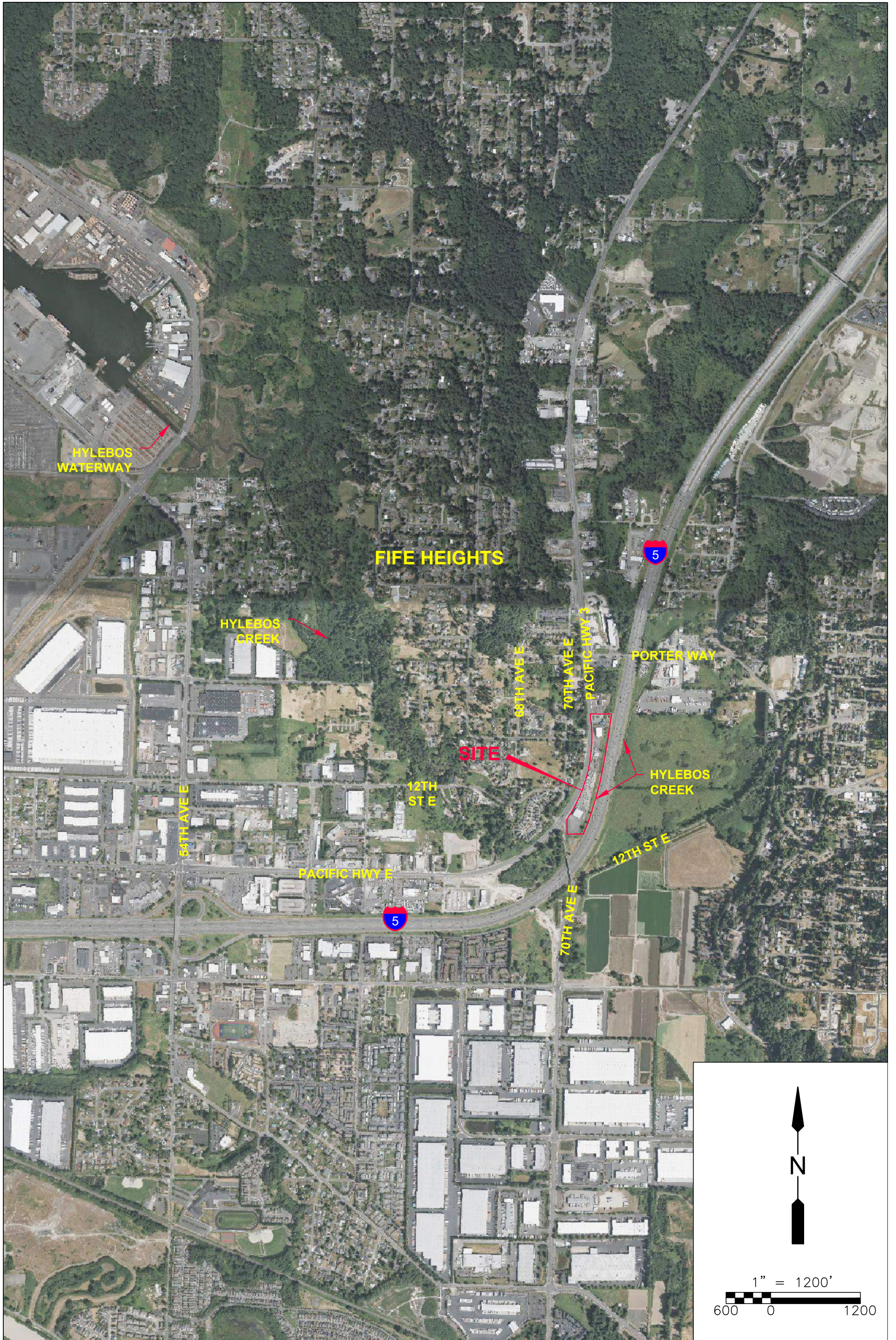

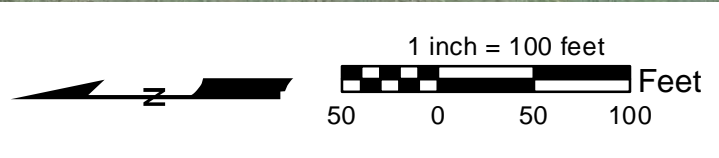
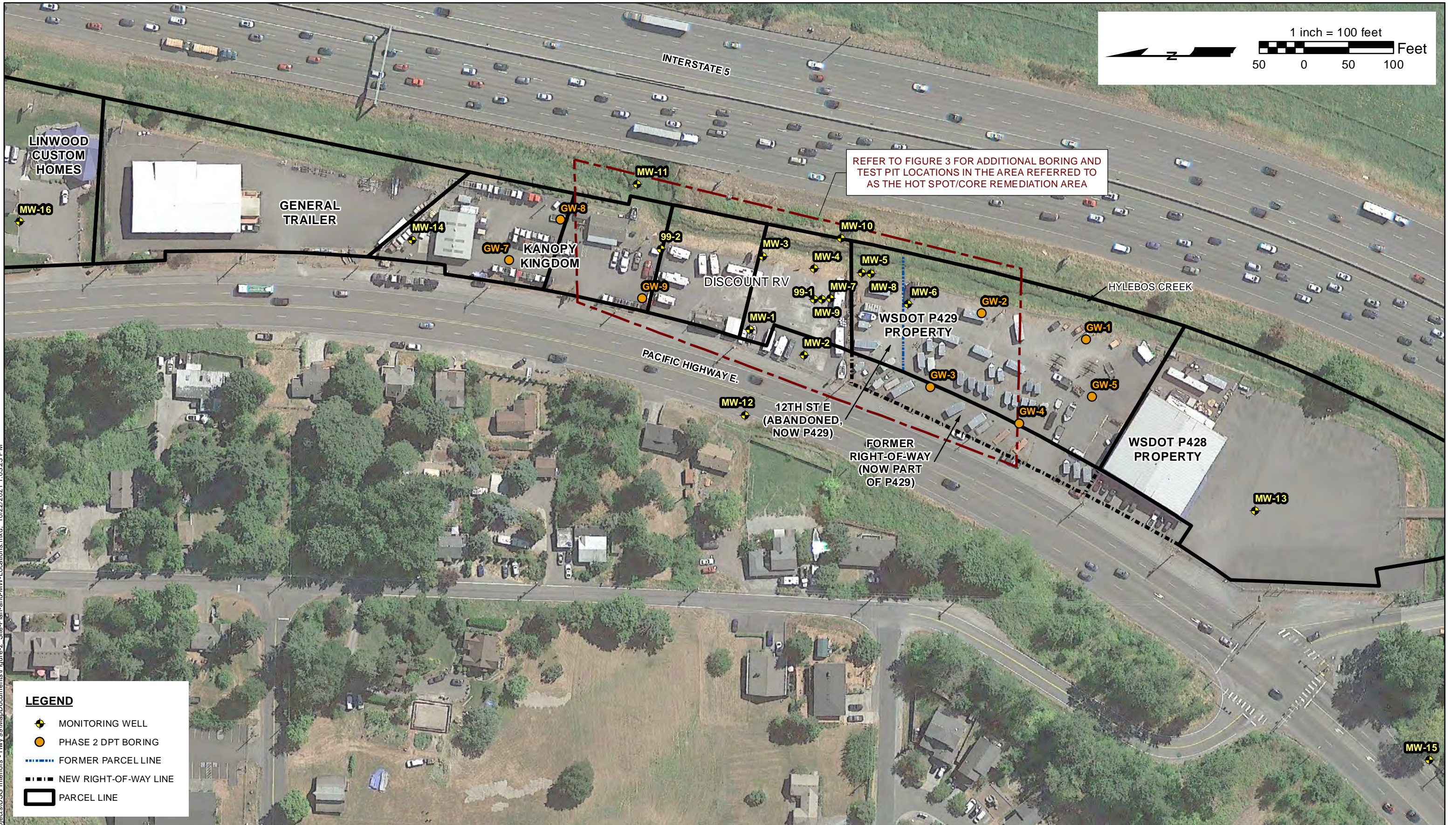

REFER TO FIGURE 3 FOR ADDITIONAL BORING AND TEST PIT LOCATIONS IN THE AREA REFERRED TO AS THE HOT SPOT/CORE REMEDIATION AREA

LEGEND

- MONITORING WELL
- PHASE 2 DPT BORING
- FORMER PARCEL LINE
- NEW RIGHT-OF-WAY LINE
- PARCEL LINE

SOURCE: GOOGLE EARTH PRO, 2021, IMAGE DATE AUGUST 20, 2020



**USG INTERIORS/HIGHWAY 99 SITE
MILTON, WASHINGTON**

**FIGURE NO. 2
SITE PLAN AND REMEDIAL INVESTIGATION
GROUNDWATER SAMPLE LOCATION MAP**

DOCUMENT PATH: E:\Projects\USG Interiors - Hwy 99\MapDocuments\Figure-2_Site-Plan-and-MW-Locations.mxd, 10/22/2021 1:03:23 PM

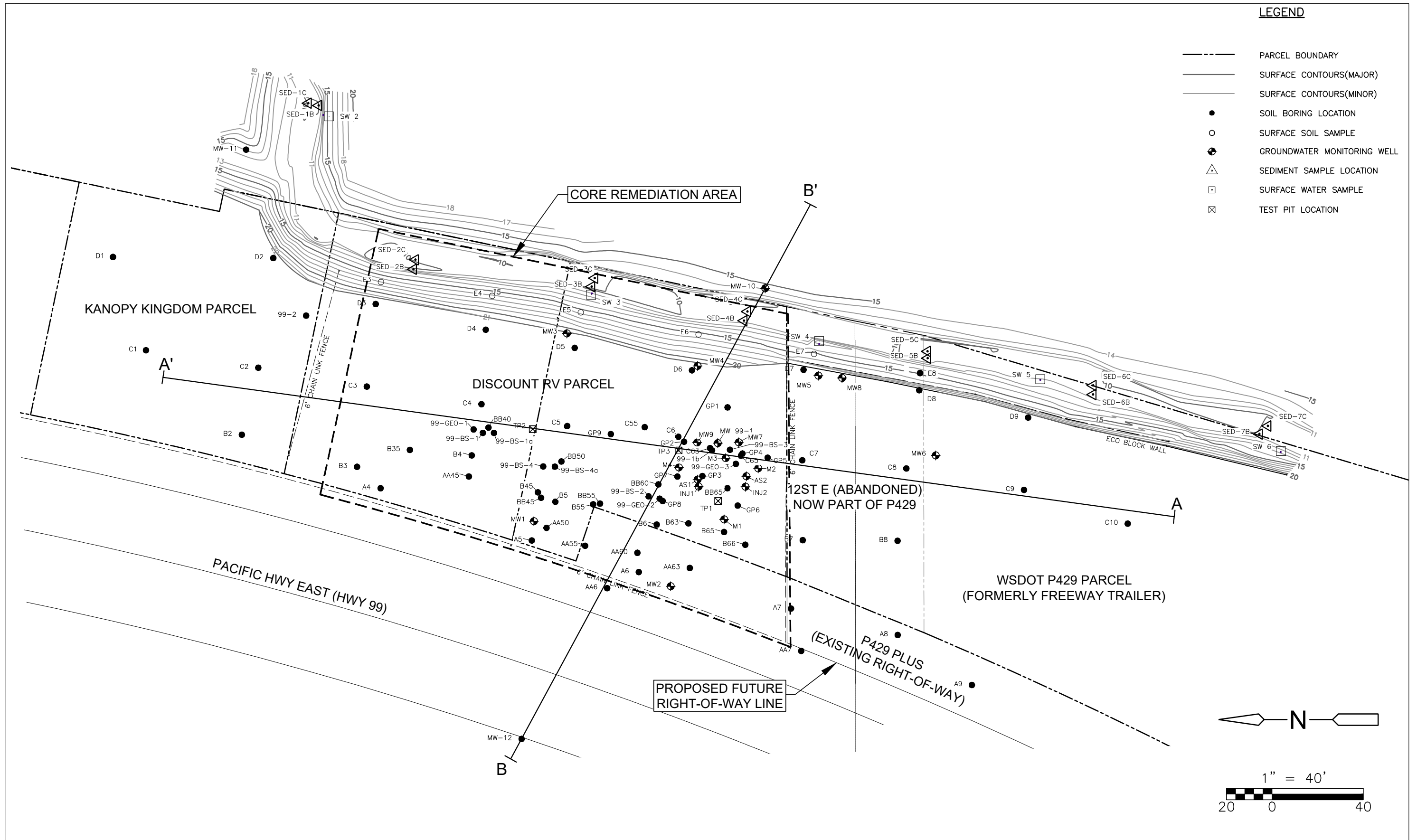

C:\pw_pi1\thomastj\d2608406\Figure 4.dwg SAVED:10/1/21 PRINTED:10/1/21 BY:THOMASTJ

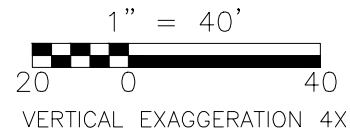
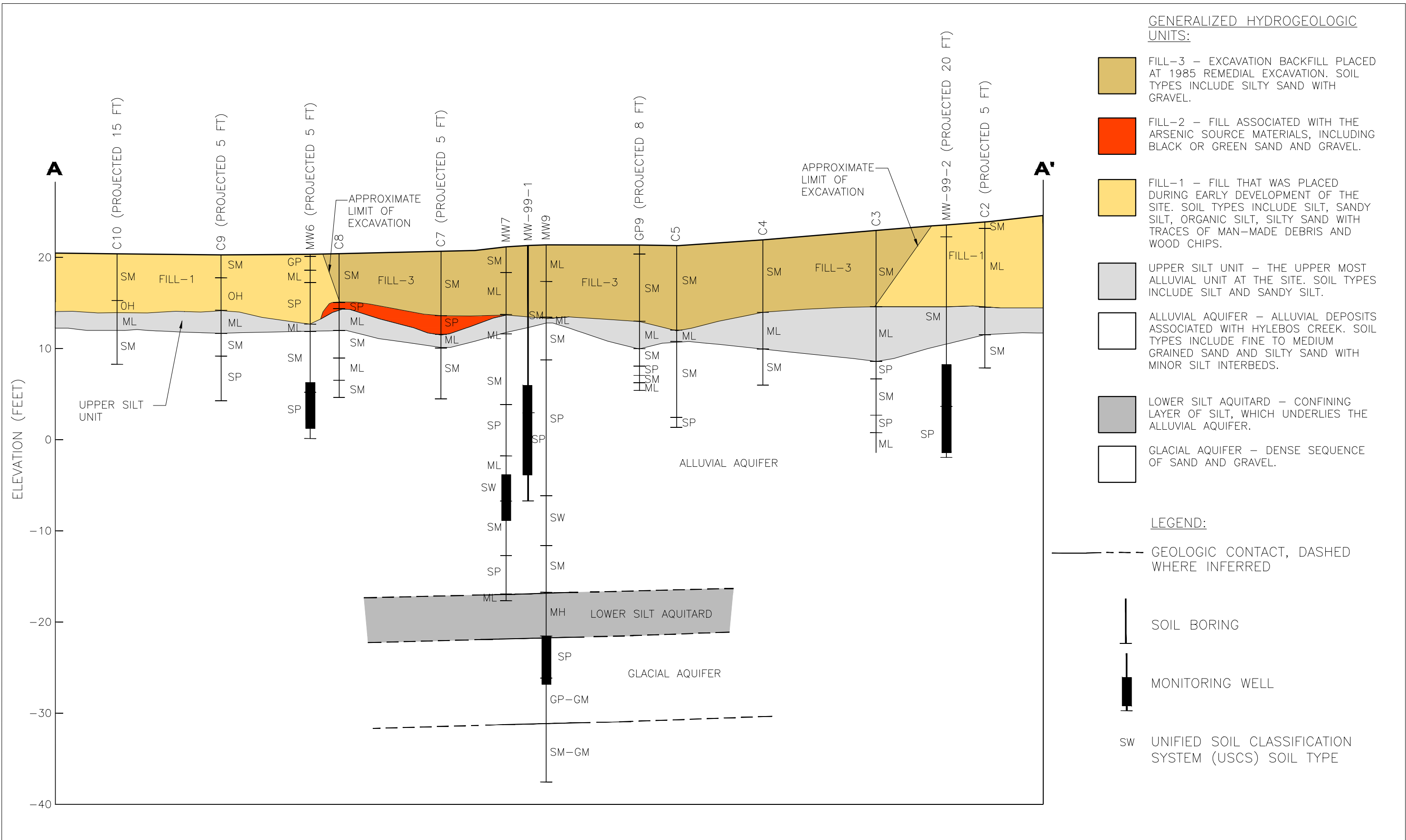

USG INTERIORS/HIGHWAY 99 SITE
 MILTON, WASHINGTON

FIGURE NO. 4
 GEOLOGIC CROSS SECTION A-A'

C:\pw_p11\thomastj\d2608406\Figure 5.dwg SAVED: 10/1/21 PRINTED: 10/1/21 BY: THOMASTJ

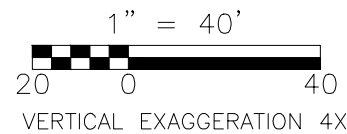
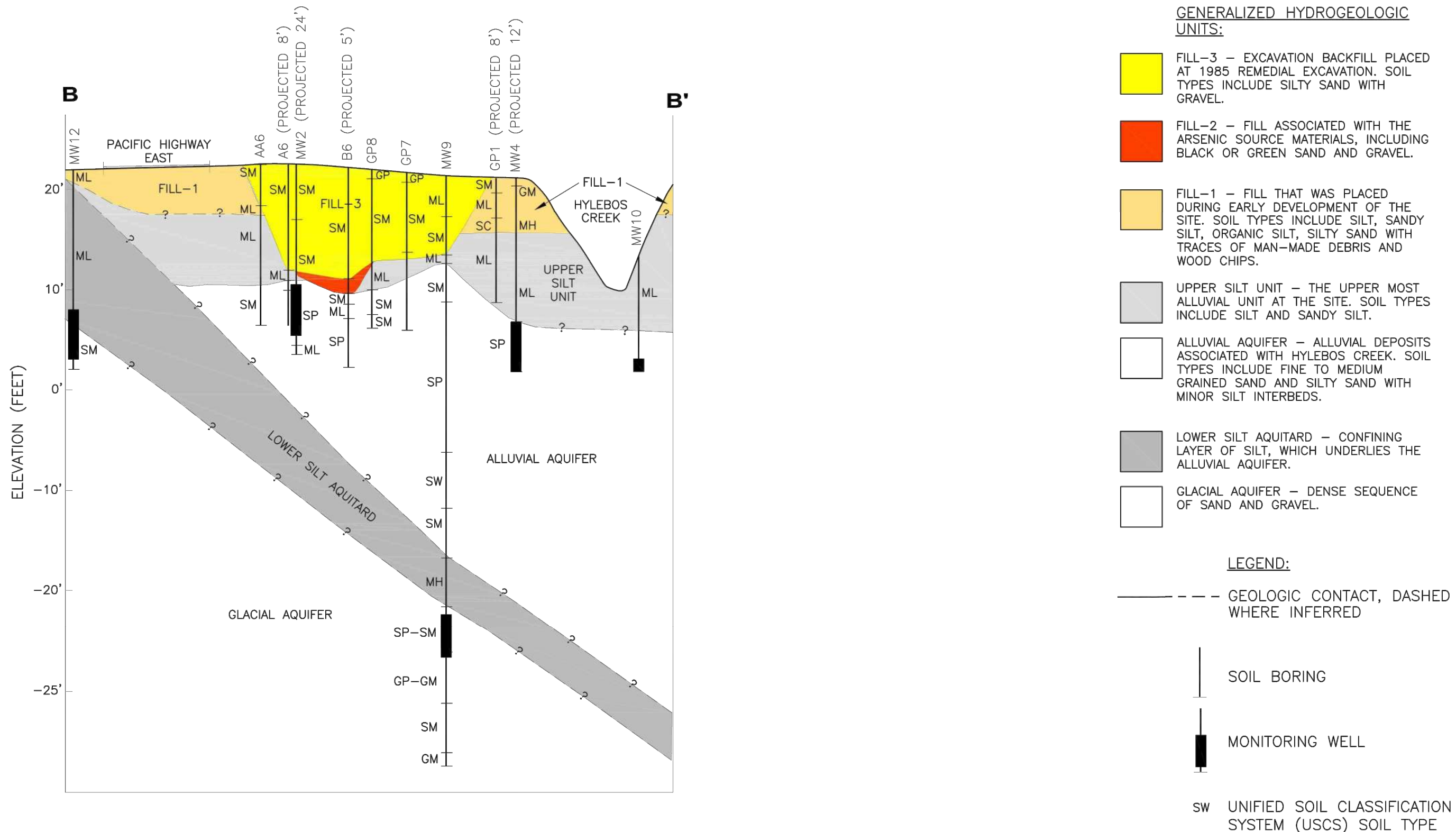

USG INTERIORS/HIGHWAY 99 SITE
MILTON, WASHINGTON

FIGURE NO. 5
GEOLOGIC CROSS SECTION B-B'

C:\pw_p11\thomastj\d2608406\Figure 6.dwg SAVED: 10/12/21 PRINTED: 10/13/21 BY: THOMASTU

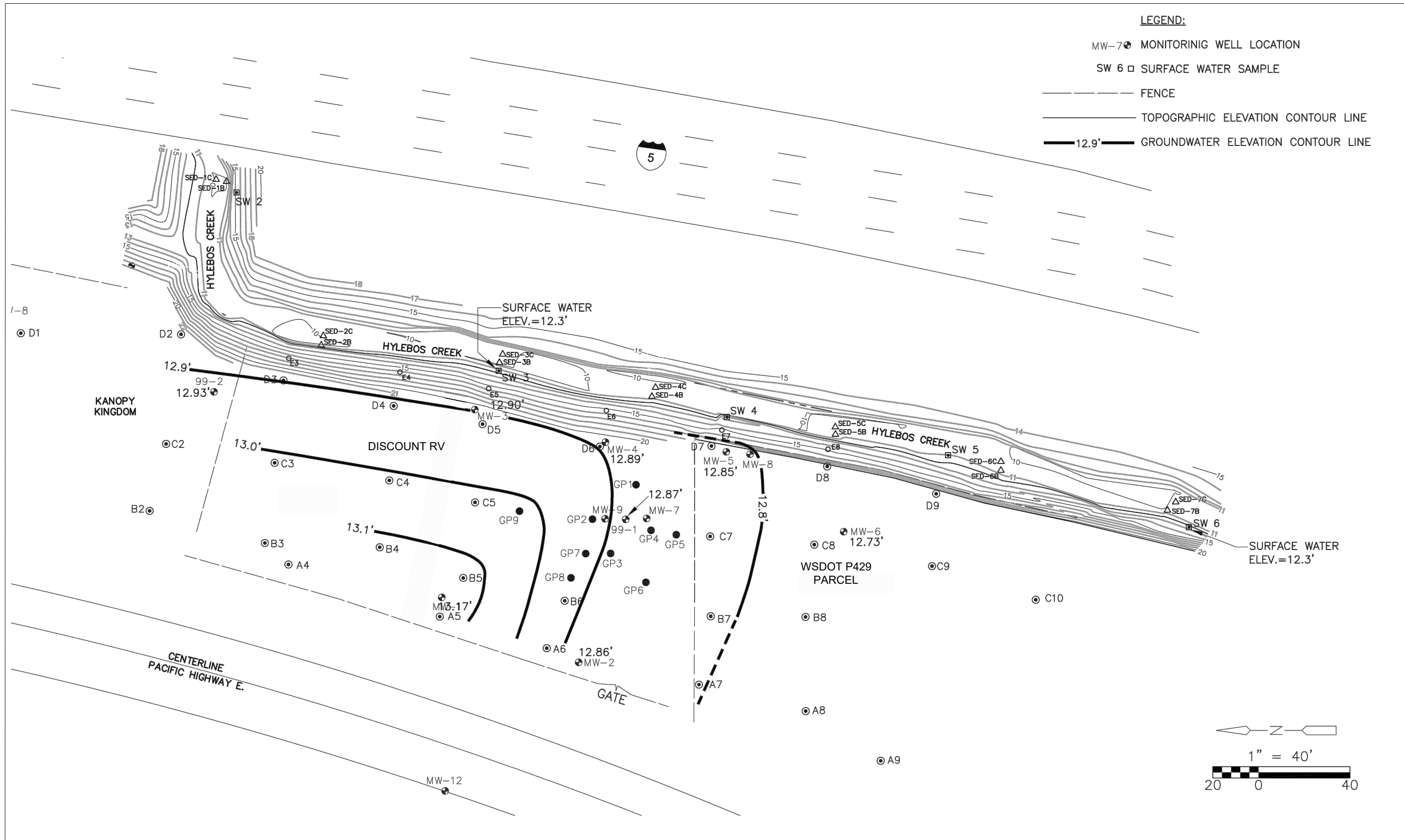

USG INTERIORS/HIGHWAY 99 SITE
MILTON, WASHINGTON

FIGURE NO. 6
GROUNDWATER ELEVATION CONTOUR MAP
ON JULY 15, 2010



C:\pw_p11\casean\d3124383\Figure 7.dwg SAVED:6/28/22 PRINTED:6/28/22 BY:CASEAN

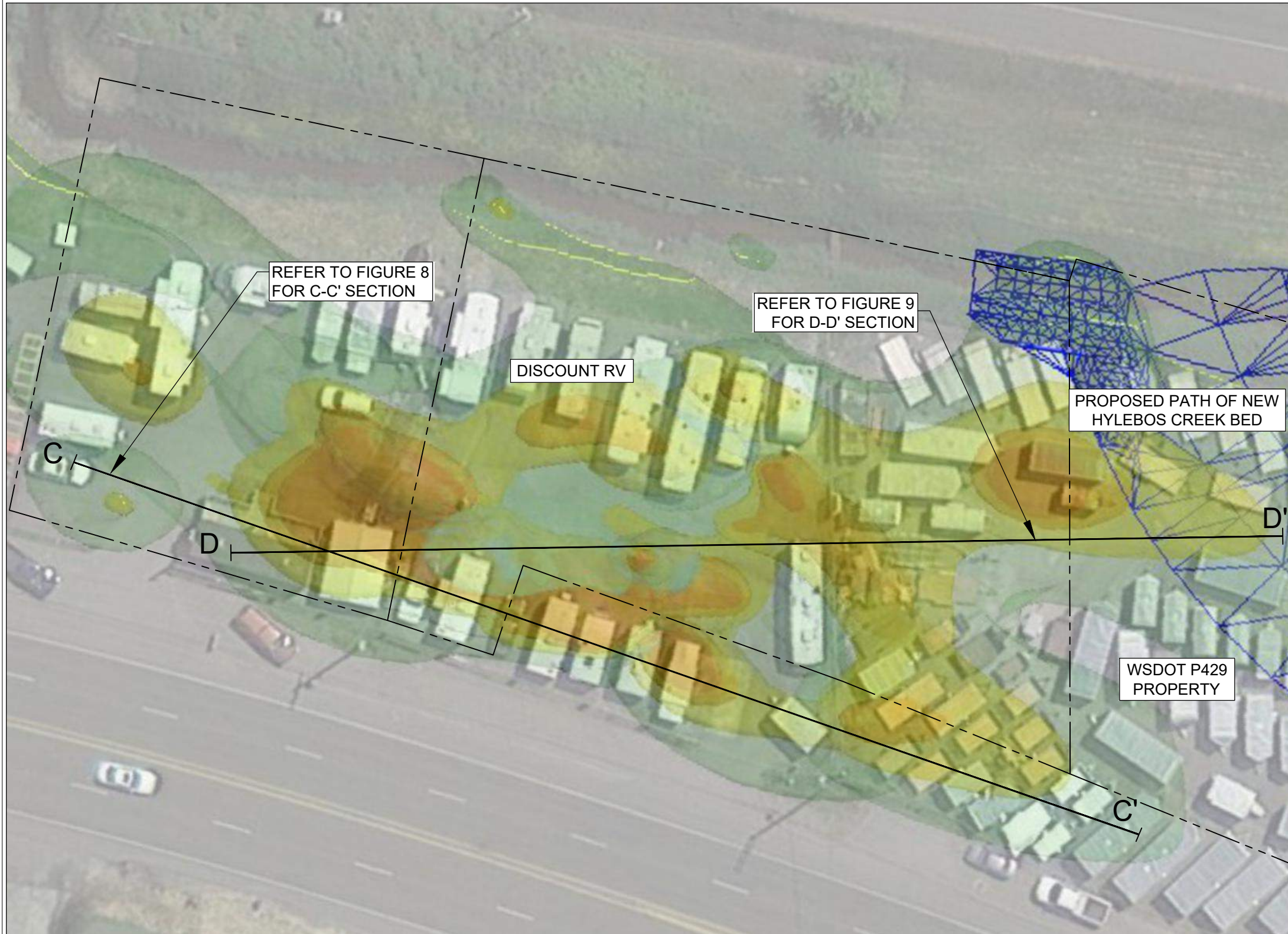

LEGEND:

- ARSENIC CONCENTRATION > 500 PPM
- ARSENIC CONCENTRATION > 250 PPM
- ARSENIC CONCENTRATION > 90 PPM
- ARSENIC CONCENTRATION > 20 PPM
- PARCEL BOUNDARY

NOTE:

PLEASE NOTE THAT THE LEAPFROG SOFTWARE IS LIMITED IN PRESENTING THREE-DIMENSIONAL DATA FOR TWO-DIMENSIONAL VISUALIZATION. COLORS ASSOCIATED WITH THE PLUME CONCENTRATIONS MAY NOT DIRECTLY REFLECT THOSE IDENTIFIED IN THE LEGEND. FOR THE MOST ACCURATE DEPICTION OF THE PLUME COLORATION ASSOCIATED WITH THE PLUME CONCENTRATIONS, PLEASE REFER TO THE CROSS-SECTIONS ON FIGURE 8 AND FIGURE 9.

ACRONYMS:

PPM PARTS PER MILLION

DATA REFERENCES:

SURVEY, ANALYTICAL DATA COLLECTED, AND LEAPFROG MODEL BY CDM SMITH.

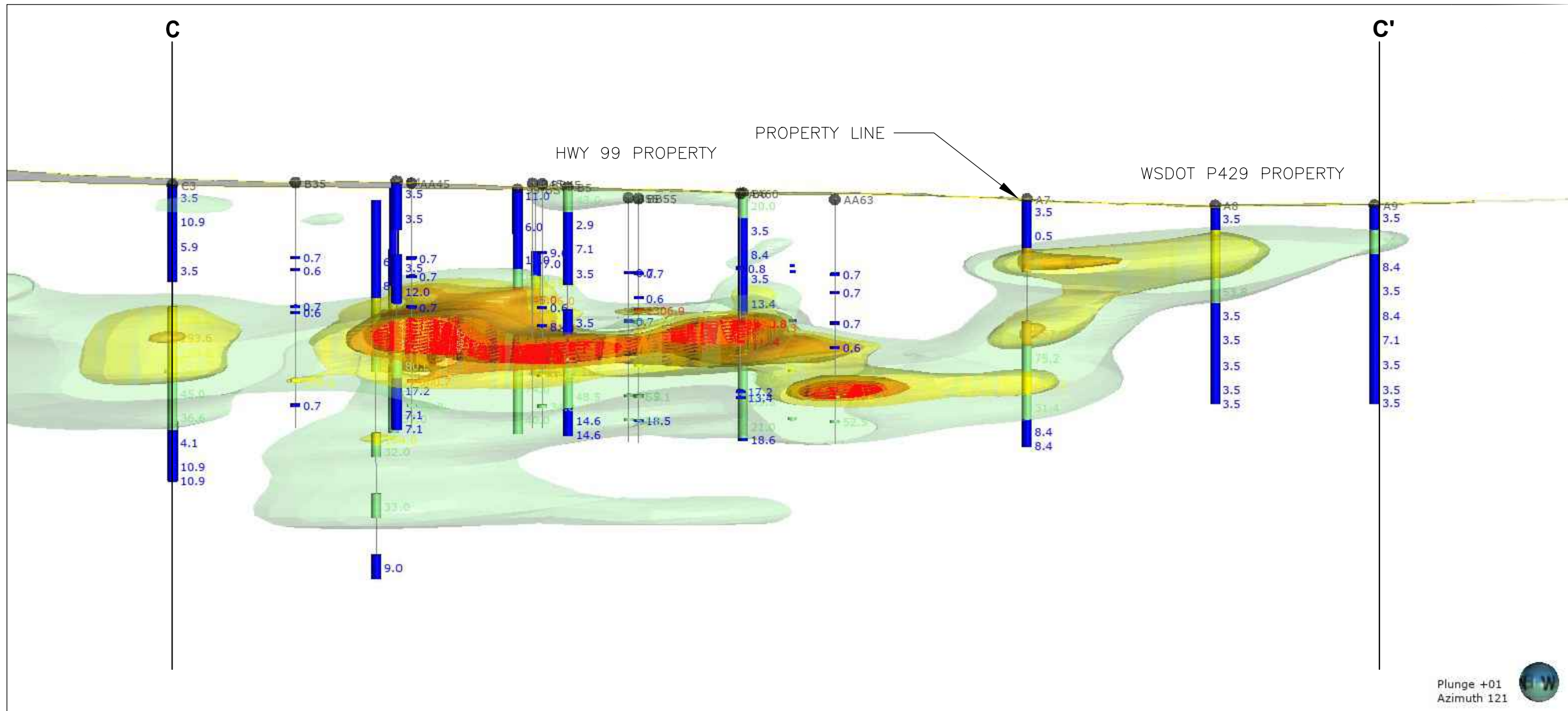

LEGEND:

	ARSENIC CONCENTRATION > 500 PPM
	ARSENIC CONCENTRATION > 250 PPM
	ARSENIC CONCENTRATION > 90 PPM
	ARSENIC CONCENTRATION > 20 PPM
	ARSENIC CONCENTRATION < 20 PPM

ACRONYMS:
PPM PARTS PER MILLION

DATA REFERENCES:
SURVEY, SUBSURFACE, AND ANALYTICAL DATA COLLECTED AS PART OF THE REMEDIAL INVESTIGATION AND LATER INVESTIGATIONS PERFORMED BY CDM SMITH.



USG INTERIORS/HIGHWAY 99 SITE
MILTON, WASHINGTON

FIGURE NO. 8
LEAPFROG MODEL CROSS SECTION C-C'

C:\pw_p11\casean\d3124383\Figure 9.dwg SAVEd:6/28/22 PRINTED:6/28/22 BY:CASEAN

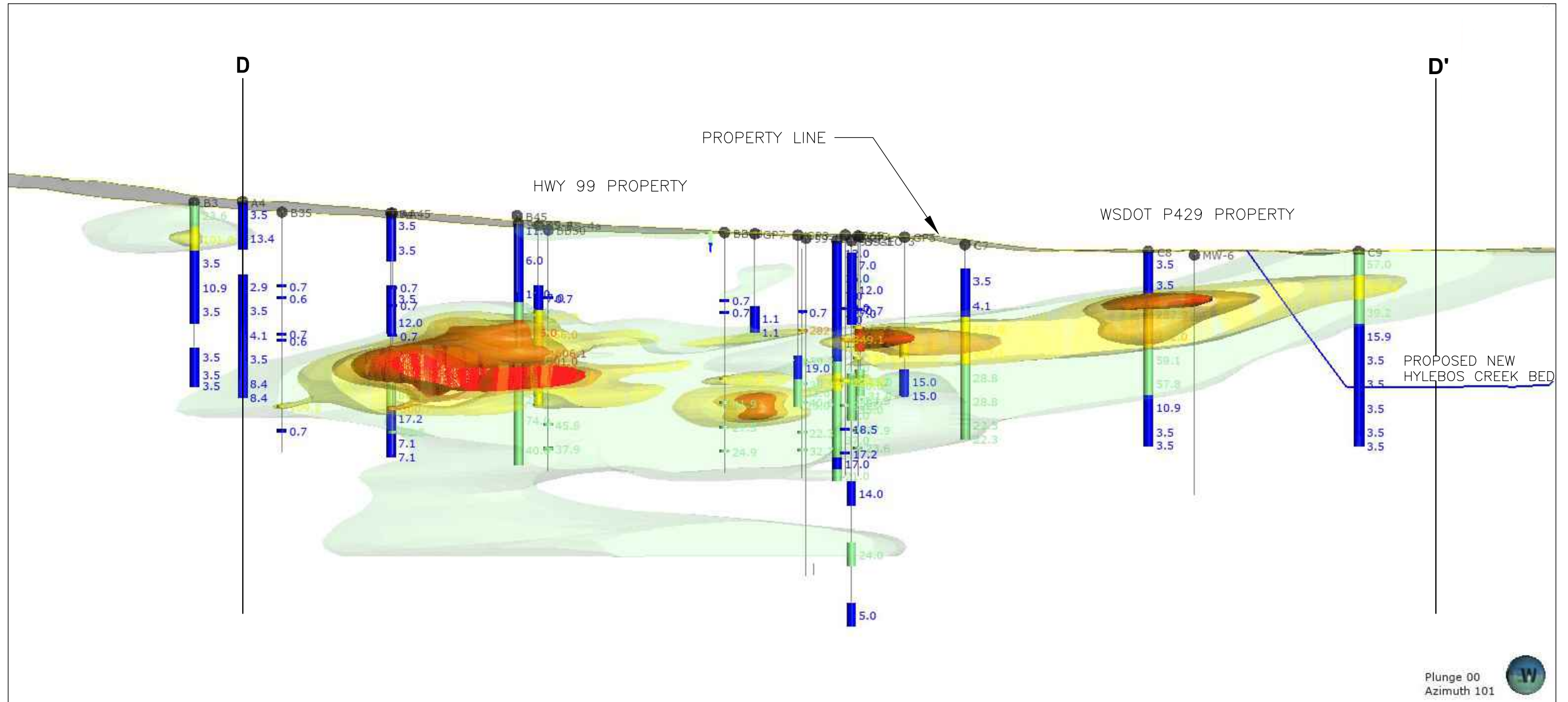

Plunge 00
Azimuth 101

LEGEND:

	ARSENIC CONCENTRATION > 500 PPM
	ARSENIC CONCENTRATION > 250 PPM
	ARSENIC CONCENTRATION > 90 PPM
	ARSENIC CONCENTRATION > 20 PPM
	ARSENIC CONCENTRATION < 20 PPM

ACRONYMS:
PPM PARTS PER MILLION

DATA REFERENCES:
SURVEY, SUBSURFACE, AND ANALYTICAL DATA COLLECTED AS PART OF THE REMEDIAL INVESTIGATION AND LATER INVESTIGATIONS PERFORMED BY CDM SMITH.



USG INTERIORS/HIGHWAY 99 SITE
MILTON, WASHINGTON

FIGURE NO. 9
LEAPFROG MODEL CROSS SECTION D-D'

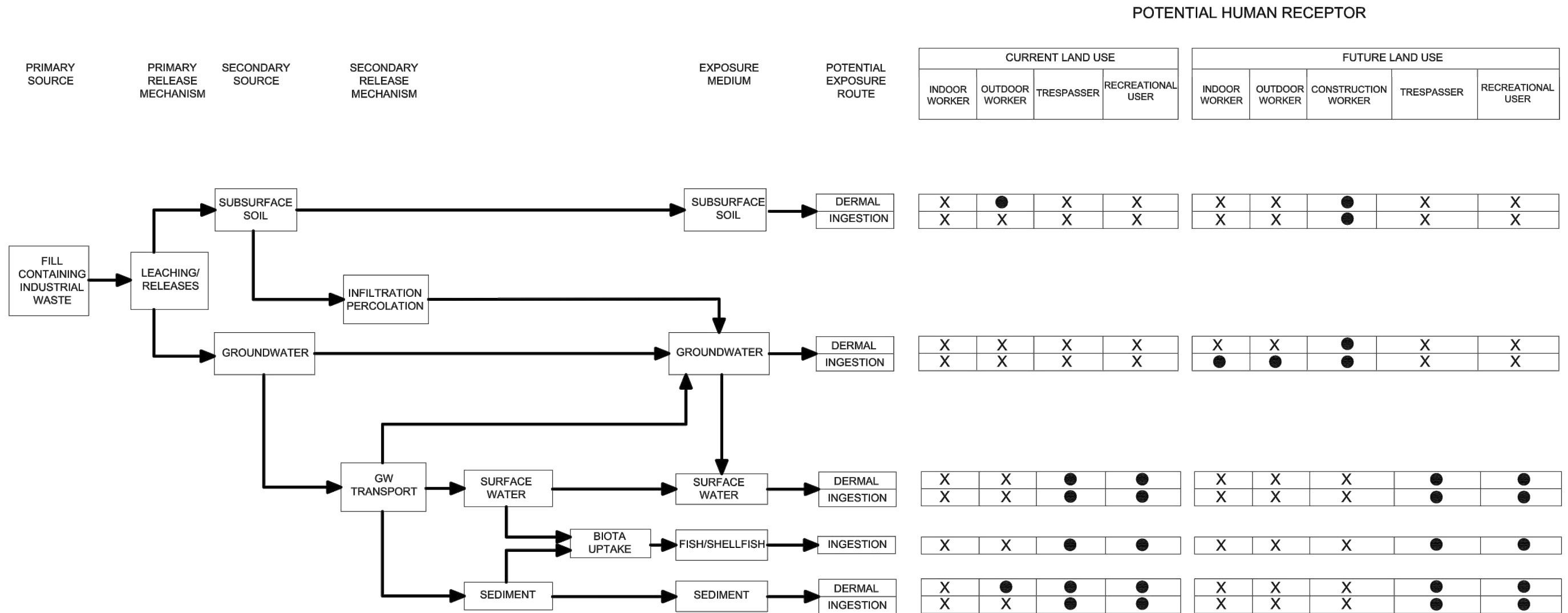

LEGEND:

- COMPLETE EXPOSURE PATHWAY
- X INCOMPLETE EXPOSURE PATHWAY

C:\pw_p11\casean\d3124383\Figure 12.dwg SAVED: 6/27/22 PRINTED: 6/28/22 BY: CASEAN

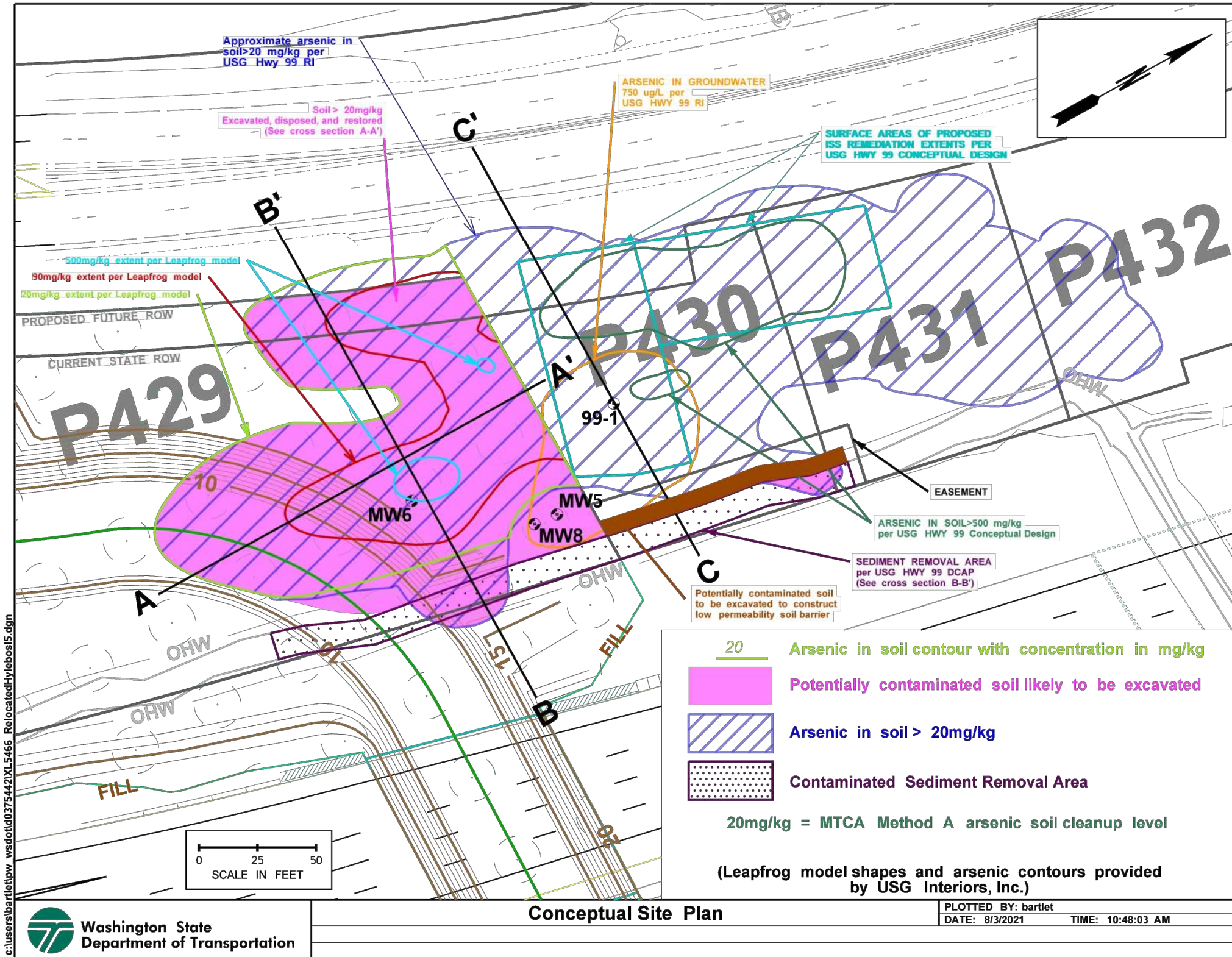

REFERENCE: INNOVEX ENVIRONMENTAL MANAGEMENT, INC. 2021. SR 167/I-5 TO SR 509 - NEW EXPRESSWAY, USG HIGHWAY 99 SITE, HYLEBOS CREEK CONTAMINATED SEDIMENT REMOVAL AND PARCEL P 429 PLUS SOIL EXCAVATION, INTERIM ACTION WORK PLAN, PREPARED FOR WASHINGTON STATE DEPARTMENT OF TRANSPORTATION. SEPTEMBER 15.

C:\pw_p11\casean\d3124383\Figure 1.3.dwg SAVED: 6/27/22 PRINTED: 6/28/22 BY: CASEAN

c:\users\bartlet\pwworking\dot0375442\XL5466_RelocatedHylebos15.dgn

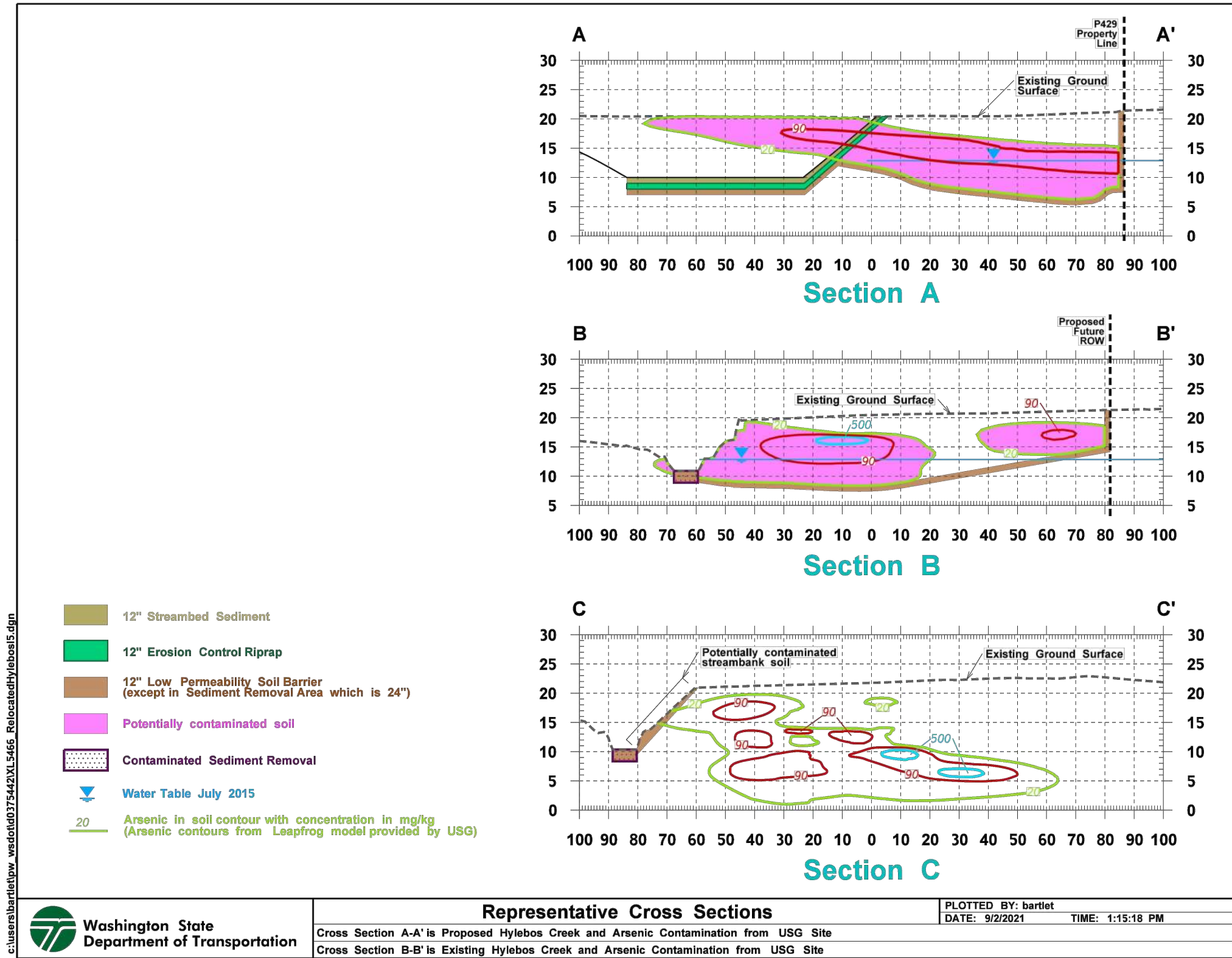

REFERENCE: INNOVEX ENVIRONMENTAL MANAGEMENT, INC. 2021. SR 167/I-5 TO SR 509 - NEW EXPRESSWAY, USG HIGHWAY 99 SITE, HYLEBOS CREEK CONTAMINATED SEDIMENT REMOVAL AND PARCEL P 429 PLUS SOIL EXCAVATION, INTERIM ACTION WORK PLAN, PREPARED FOR WASHINGTON STATE DEPARTMENT OF TRANSPORTATION. SEPTEMBER 15.



USG INTERIORS/HIGHWAY 99 SITE
 MILTON, WASHINGTON

FIGURE NO. 13
 PLANNED REMEDIAL EXCAVATION WSDOT P429 PLUS
 PROPERTY AND CREEK BED - CROSS SECTION VIEWS

XREFs: [36146-SURV-TP01, S_1117_1, SHEETBORDER Figure] Images: []
Last saved by: CASEAN Time: 6/28/2022 8:51:07 AM
C:\pw_pl1\casean\3124417\HW99.dwg

C:\pw_pl1\casean\d3124417\HW99.dwg SAVED: 6/28/22 PRINTED: 6/28/22 BY: CASEAN



PLAN

1" = 30'

1" = 30'

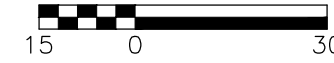

LEGEND:

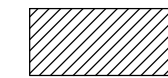

MODELED IMPACTED SOILS EXCEEDING 20 PPM TOTAL ARSENIC.



TREATMENT AREAS.

NOTES:

1. BASEMAP PROVIDED FROM DRAWING ENTITLED "USG HWY 99 REMEDIAL INVESTIGATION SURVEY" PREPARED BY WH PACIFIC INC. ON JUNE 10, 2020.
2. ELEVATIONS NOTED ARE IN FEET AND BASED ON HORIZONTAL DATUM NAD 83 WASHINGTON STATE PLANE, SOUTH ZONE AND VERTICAL DATUM NGVD-88
3. ARSENIC CONCENTRATIONS >20PPM EXTEND OUTSIDE HIGHWAY 99 PROPERTY BOUNDARY. REMEDIATION OF SEDIMENT IN HYLEBOS CREEK TO BE CONDUCTED BY WSDOT AS PART OF ITS INDEPENDENT CLEANUP ACTION.

C:\pw_p11\casean\d3124417\CP001_1.dwg
SAVED: 6/28/22
PRINTED: 6/28/22
BY: CASEAN

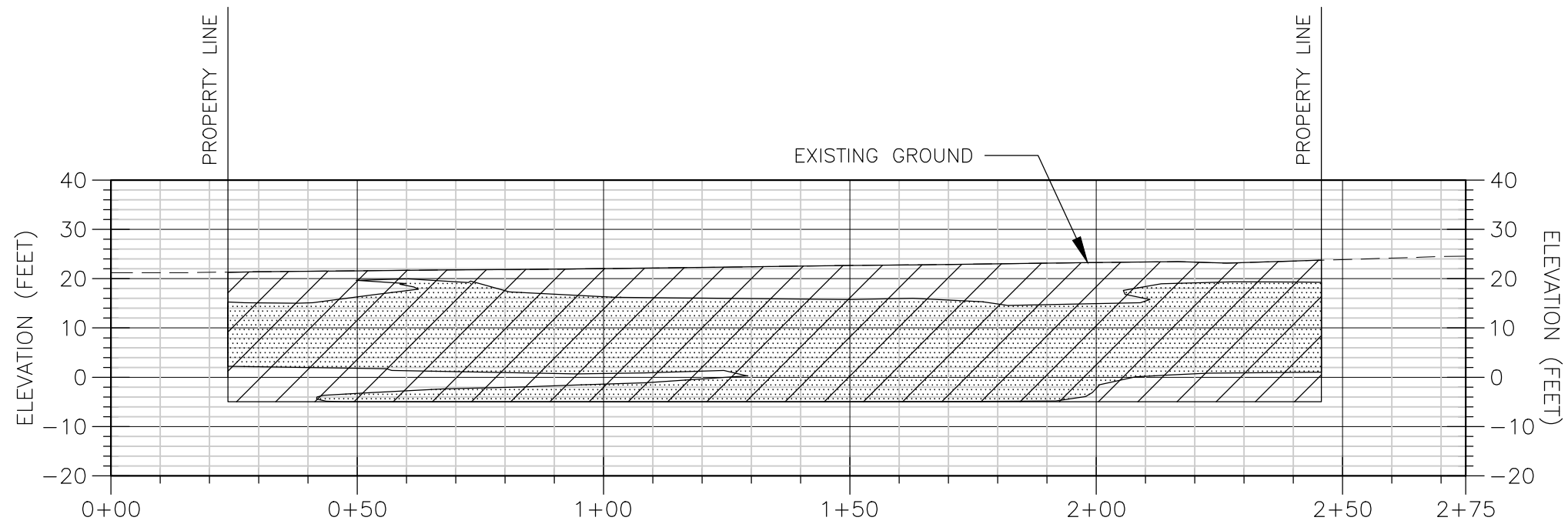

20 PPM PROFILE

LEGEND:

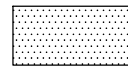

CONTAMINATED SOIL

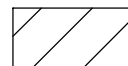

TREATMENT AREA



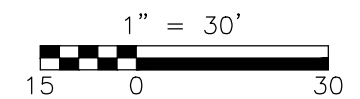

NOTES:

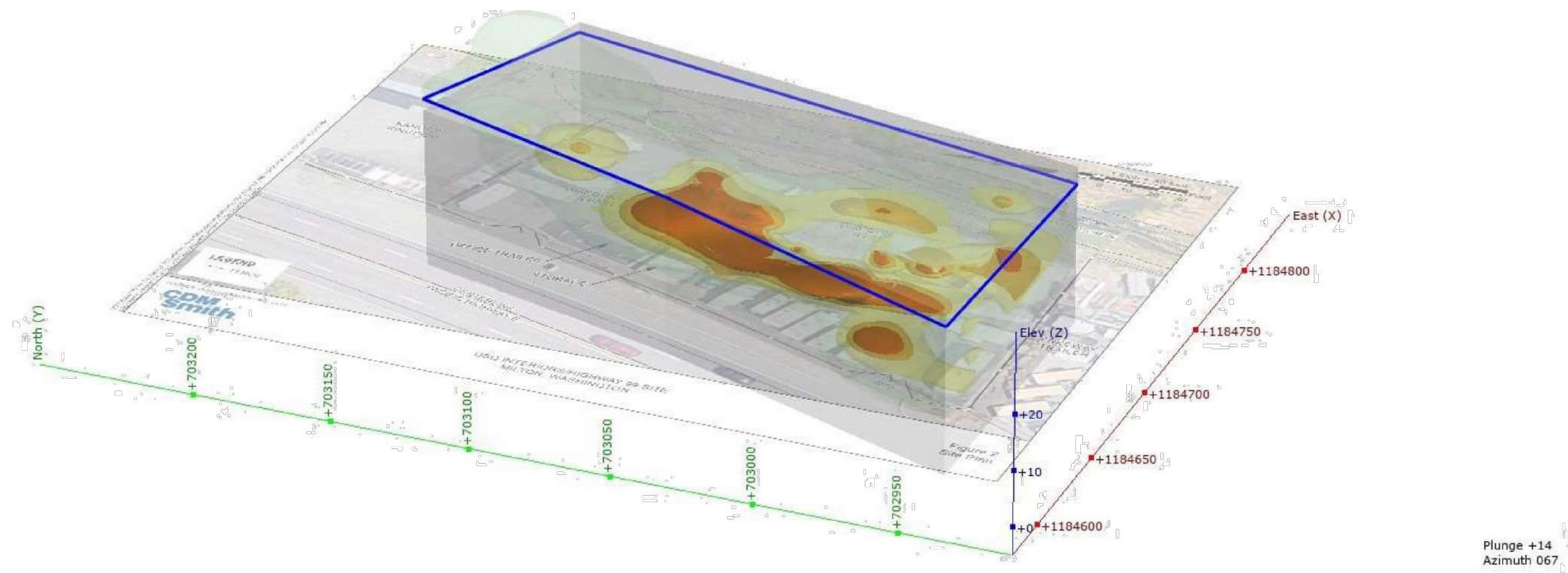
1. ARSENIC CONCENTRATIONS EXTEND OUTSIDE HIGHWAY 99 PROPERTY BOUNDARY.
2. ELEVATIONS NOTED ARE IN FEET AND BASED ON HORIZONTAL DATUM NAD 83 WASHINGTON STATE PLANE, SOUTH ZONE AND VERTICAL DATUM NGVD-88.





LEGEND:

-  ARSENIC CONCENTRATION > 500 PPM
-  ARSENIC CONCENTRATION > 250 PPM
-  ARSENIC CONCENTRATION > 90 PPM
-  ARSENIC CONCENTRATION > 20 PPM
-  SURFACE AREAS OF PROPOSED ISS EXTENTS

ACRONYMS:

PPM PARTS PER MILLION

DATA REFERENCES:

SURVEY, SUBSURFACE, AND ANALYTICAL DATA COLLECTED AS PART OF THE REMEDIAL INVESTIGATION PERFORMED BY CDM SMITH, JUNE 23, 2016.

XREFs: [36146-SURV-TP01_S_1117_1_SHEETBORDER Figure] Images: []
 Last saved by: CASEAN Time: 6/28/2022 8:51:07 AM
 C:\pw_pl1\casean\3124417\HW99.dwg

C:\pw_pl1\casean\d3124417\HW99.dwg SAVED: 6/28/22 PRINTED: 6/28/22 BY: CASEAN



PLAN

1" = 30'

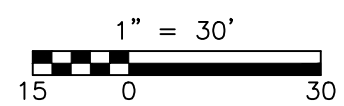

LEGEND:

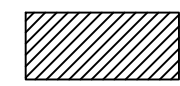

MODELED IMPACTED SOILS EXCEEDING 20 PPM TOTAL ARSENIC.

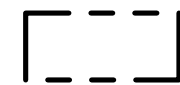

TREATMENT AREAS.

NOTES:

1. BASEMAP PROVIDED FROM DRAWING ENTITLED "USG HWY 99 REMEDIAL INVESTIGATION SURVEY" PREPARED BY WH PACIFIC INC. ON JUNE 10, 2020.
2. ELEVATIONS NOTED ARE IN FEET AND BASED ON HORIZONTAL DATUM NAD 83 WASHINGTON STATE PLANE, SOUTH ZONE AND VERTICAL DATUM NGVD-88



**USG INTERIORS/HIGHWAY 99 SITE
 MILTON, WASHINGTON**

**FIGURE NO. 17
 ALTERNATIVE 2: PROPOSED TREATMENT AREA
 OF ARSENIC > 90 PPM IN SOIL - PLAN VIEW**

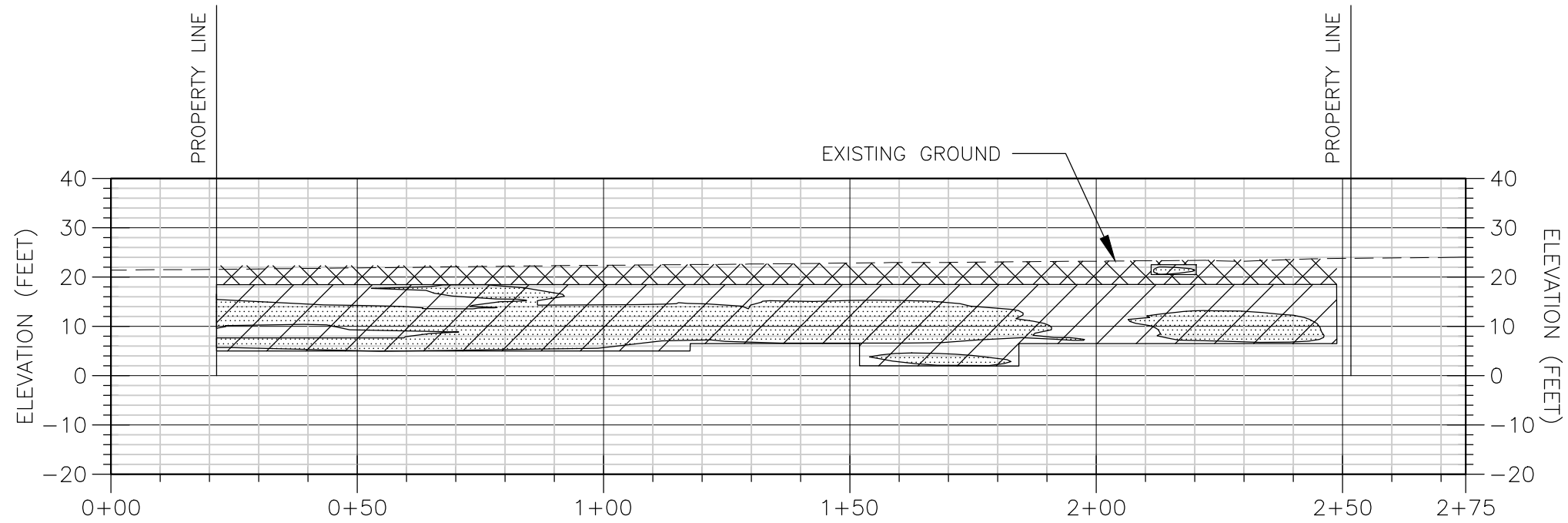

90 PPM PROFILE

LEGEND:

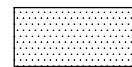

CONTAMINATED SOIL



TREATMENT AREA



PRE-EXCAVATION OF CLEAN SOILS



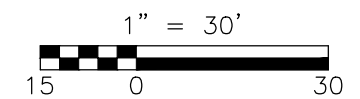

NOTES:

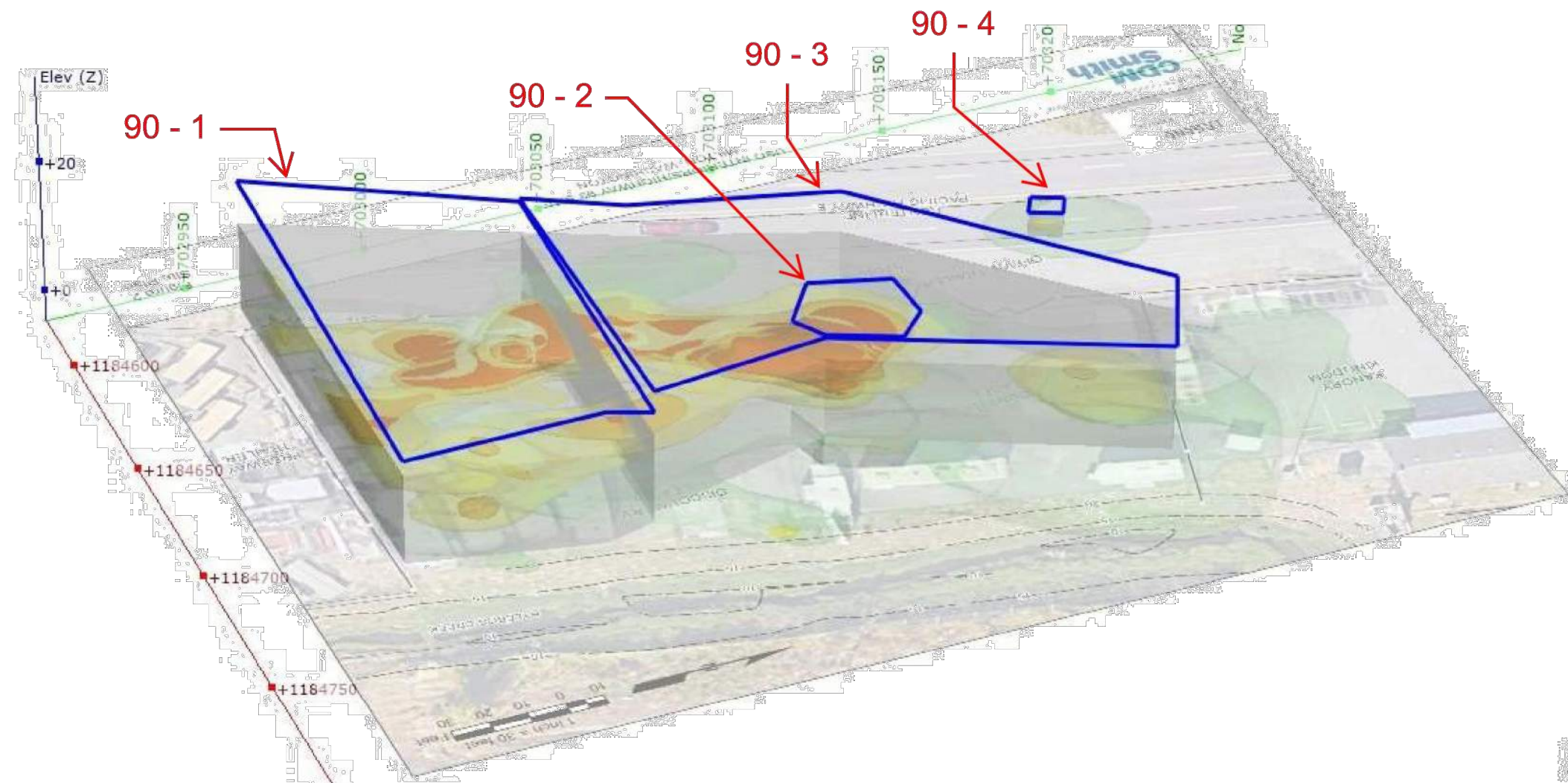
1. ARSENIC CONCENTRATIONS EXTEND OUTSIDE HIGHWAY 99 PROPERTY BOUNDARY.
2. ELEVATIONS NOTED ARE IN FEET AND BASED ON HORIZONTAL DATUM NAD 83 WASHINGTON STATE PLANE, SOUTH ZONE AND VERTICAL DATUM NGVD-88.





LEGEND:

-  ARSENIC CONCENTRATION > 500 PPM
-  ARSENIC CONCENTRATION > 250 PPM
-  ARSENIC CONCENTRATION > 90 PPM
-  ARSENIC CONCENTRATION > 20 PPM
-  SURFACE AREAS OF PROPOSED ISS EXTENTS

NOTE:

BOUNDARIES OF PROPOSED EXTENTS OF ISS TREATMENT AREAS ARE IDENTIFIED BY AREA 90-1, 90-2, 90-3 AND AREA 90-4.

ACRONYMS:

PPM PARTS PER MILLION

DATA REFERENCES:

SURVEY, SUBSURFACE, AND ANALYTICAL DATA COLLECTED AS PART OF THE REMEDIAL INVESTIGATION PERFORMED BY CDM SMITH, JUNE 23, 2016.

XREFs: [36146-SURV-TP01_S_1117_1_SHEETBORDER Figure] Images: []
Last saved by: CASEAN Time: 6/28/2022 8:51:07 AM
C:\pw_pl1\caseand3124417\HW99.dwg

C:\pw_pl1\casean\d3124417\HW99.dwg SAVED: 6/28/22 PRINTED: 6/28/22 BY: CASEAN



PLAN

1" = 30'

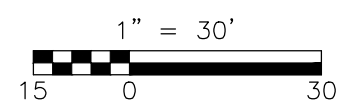

LEGEND:

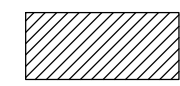

MODELED IMPACTED SOILS EXCEEDING 250 PPM TOTAL ARSENIC.

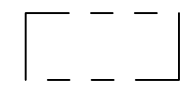

TREATMENT AREAS.

NOTES:

1. BASEMAP PROVIDED FROM DRAWING ENTITLED "USG HWY 99 REMEDIAL INVESTIGATION SURVEY" PREPARED BY WH PACIFIC INC. ON JUNE 10, 2020.
2. ELEVATIONS NOTED ARE IN FEET AND BASED ON HORIZONTAL DATUM NAD 83 WASHINGTON STATE PLANE, SOUTH ZONE AND VERTICAL DATUM NGVD-88



USG INTERIORS/HIGHWAY 99 SITE
MILTON, WASHINGTON

FIGURE NO. 20
ALTERNATIVE 3: PROPOSED TREATMENT AREA
OF ARSENIC > 250 PPM IN SOIL - PLAN VIEW

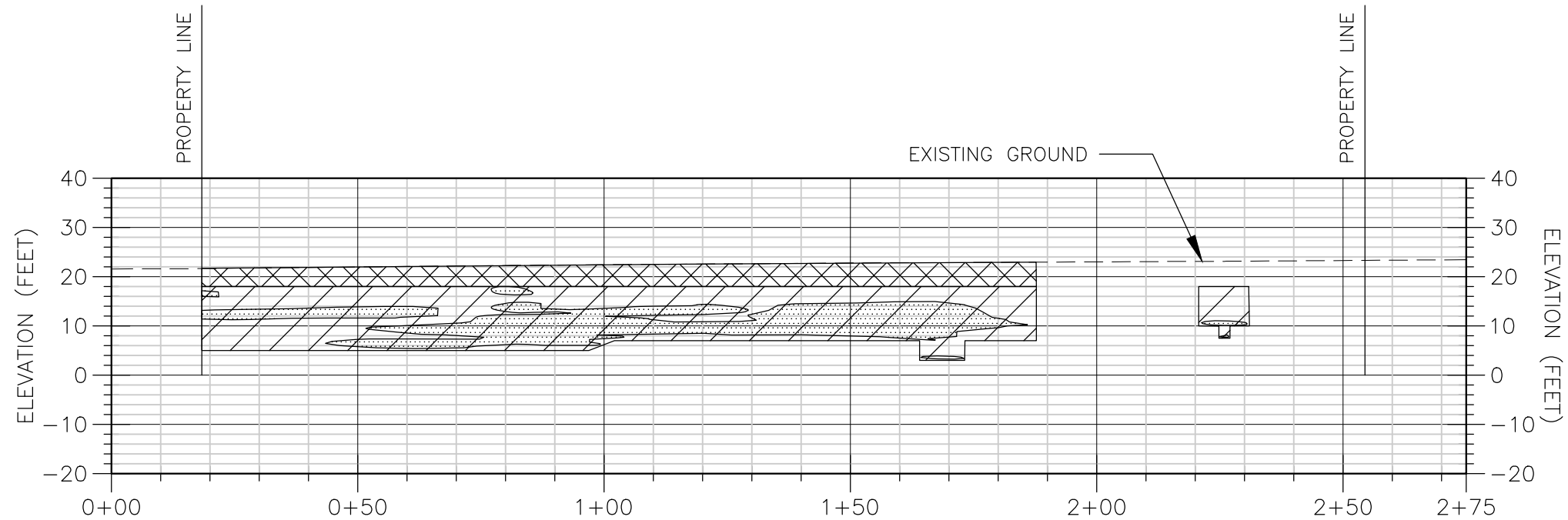

250 PPM PROFILE

LEGEND:

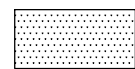

CONTAMINATED SOIL



TREATMENT AREA



PRE-EXCAVATION OF CLEAN SOILS

NOTES:

1. ARSENIC CONCENTRATIONS EXTEND OUTSIDE HIGHWAY 99 PROPERTY BOUNDARY.
2. ELEVATIONS NOTED ARE IN FEET AND BASED ON HORIZONTAL DATUM NAD 83 WASHINGTON STATE PLANE, SOUTH ZONE AND VERTICAL DATUM NGVD-88.

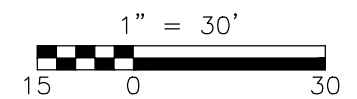

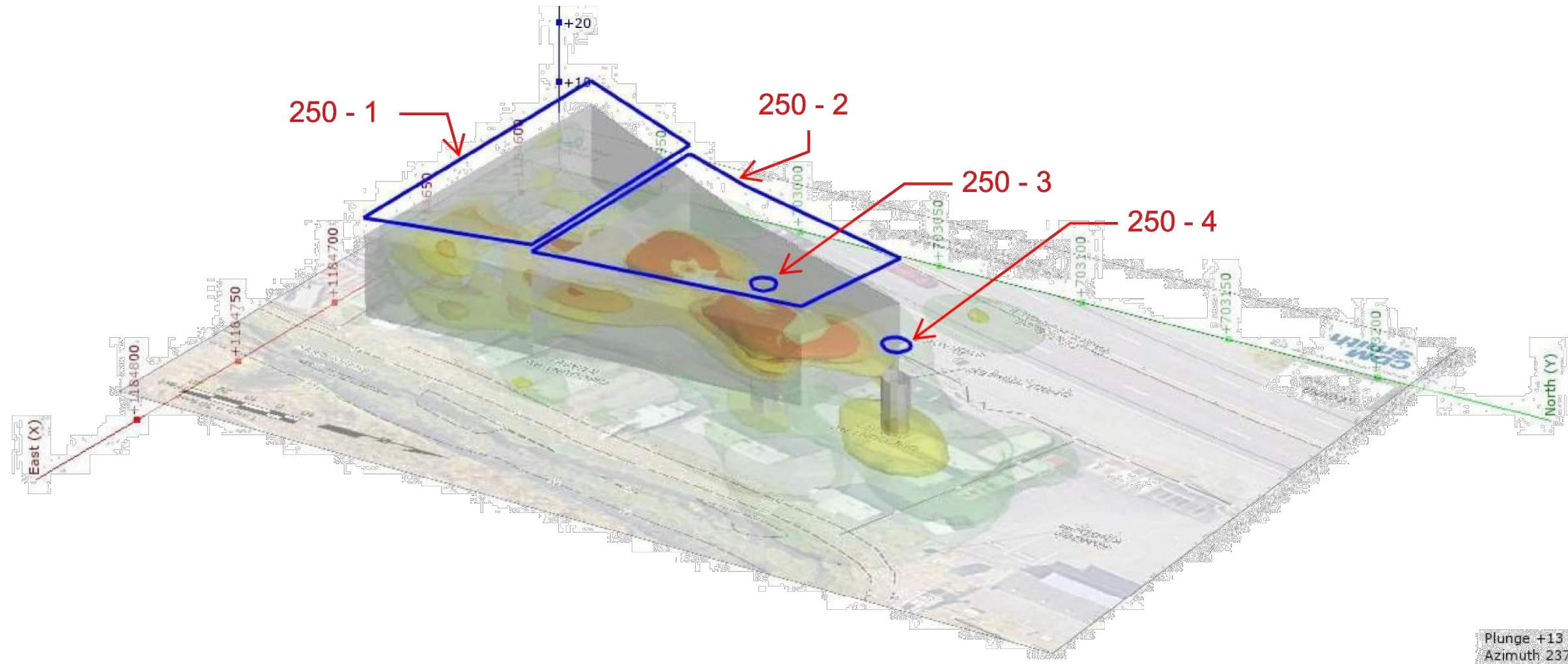

LEGEND:

- ARSENIC CONCENTRATION > 500 PPM
- ARSENIC CONCENTRATION > 250 PPM
- ARSENIC CONCENTRATION > 90 PPM
- ARSENIC CONCENTRATION > 20 PPM
- SURFACE AREAS OF PROPOSED ISS EXTENTS

NOTE:

BOUNDARIES OF PROPOSED EXTENTS OF ISS TREATMENT AREAS ARE IDENTIFIED BY AREA 250-1, 250-2, 250-3 AND AREA 250-4.

ACRONYMS:

PPM PARTS PER MILLION

DATA REFERENCES:

SURVEY, SUBSURFACE, AND ANALYTICAL DATA COLLECTED AS PART OF THE REMEDIAL INVESTIGATION PERFORMED BY CDM SMITH, JUNE 23, 2016.

XREFs: [36146-SURV-TP01_S_1117_1_SHEETBORDER Figure] Images: []
Last saved by: CASEAN Time: 6/28/2022 8:51:07 AM
C:\pw_pl1\casean\3124417\HW99.dwg

C:\pw_pl1\casean\d3124417\HW99.dwg SAVED: 6/28/22 PRINTED: 6/28/22 BY: CASEAN



PLAN

1" = 30'

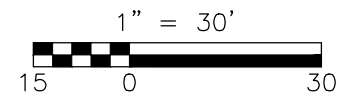

LEGEND:

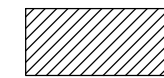

MODELED IMPACTED SOILS EXCEEDING 500 PPM TOTAL ARSENIC.



TREATMENT AREAS.

NOTES:

1. BASEMAP PROVIDED FROM DRAWING ENTITLED "USG HWY 99 REMEDIAL INVESTIGATION SURVEY" PREPARED BY WH PACIFIC INC. ON JUNE 10, 2020.
2. ELEVATIONS NOTED ARE IN FEET AND BASED ON HORIZONTAL DATUM NAD 83 WASHINGTON STATE PLANE, SOUTH ZONE AND VERTICAL DATUM NGVD-88

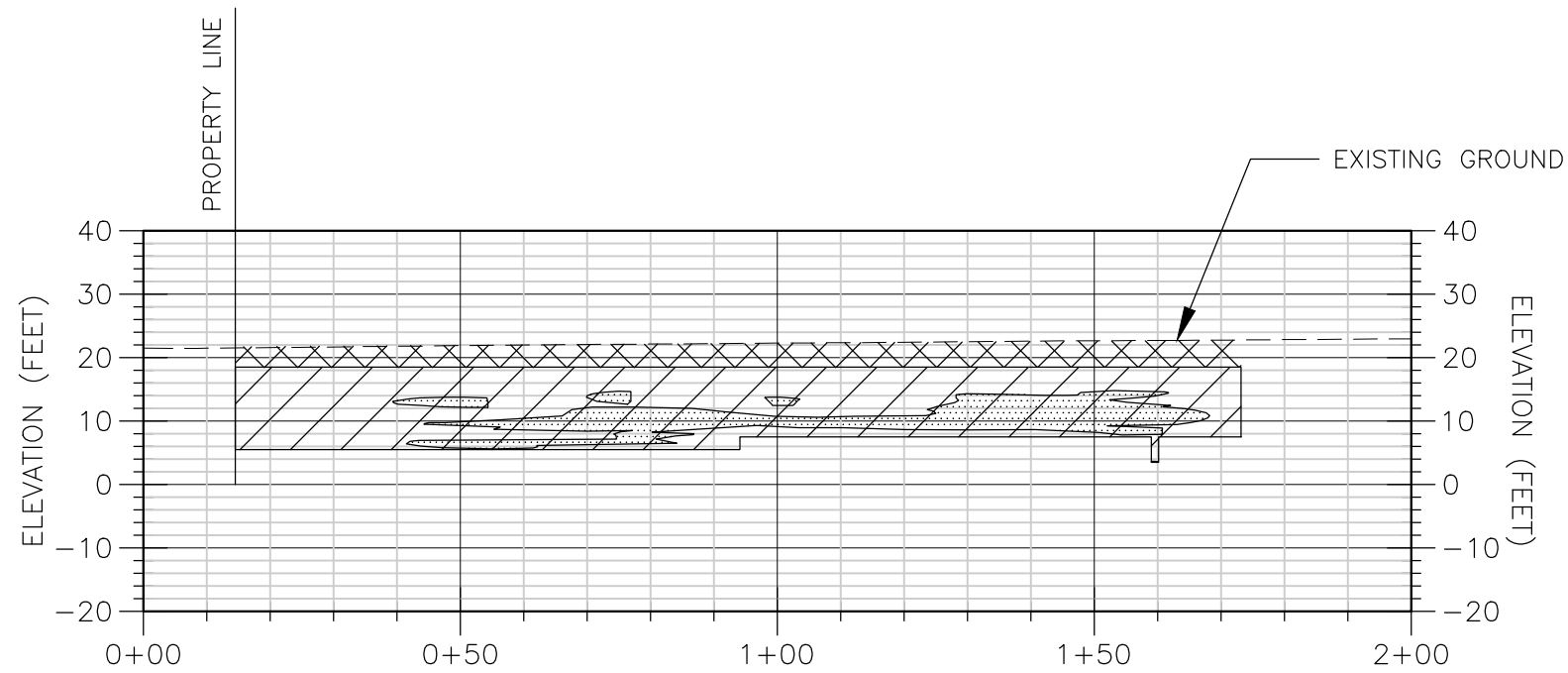

500 PPM PROFILE

LEGEND:

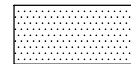

CONTAMINATED SOIL

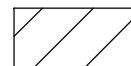

TREATMENT AREA



PRE-EXCAVATION OF CLEAN SOILS

NOTES:



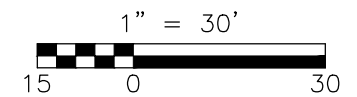

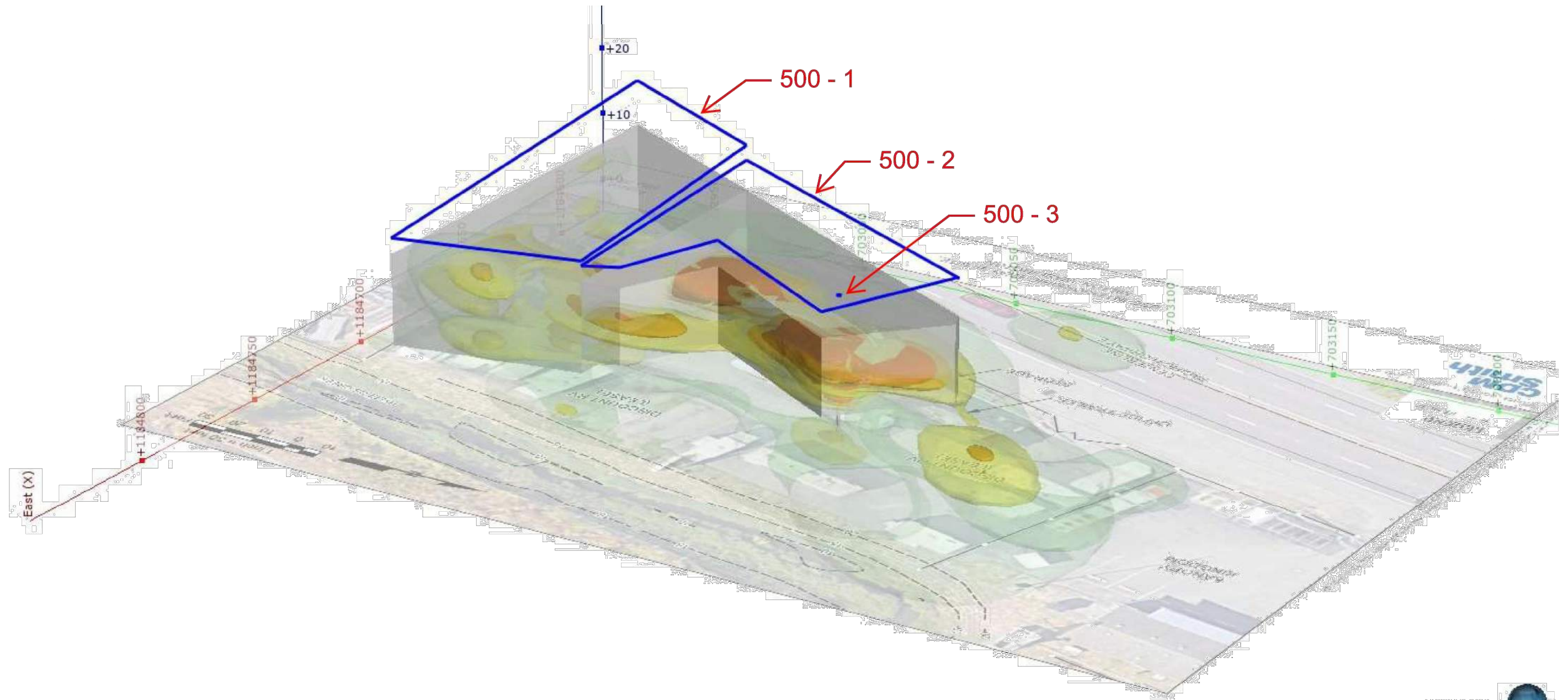
1. ARSENIC CONCENTRATIONS EXTEND OUTSIDE HIGHWAY 99 PROPERTY BOUNDARY.
2. ELEVATIONS NOTED ARE IN FEET AND BASED ON HORIZONTAL DATUM NAD 83 WASHINGTON STATE PLANE, SOUTH ZONE AND VERTICAL DATUM NGVD-88.





Plunge +11
Azimuth 238

LEGEND:

-  ARSENIC CONCENTRATION > 500 PPM
-  ARSENIC CONCENTRATION > 250 PPM
-  ARSENIC CONCENTRATION > 90 PPM
-  ARSENIC CONCENTRATION > 20 PPM
-  SURFACE AREAS OF PROPOSED ISS EXTENTS

NOTE:

BOUNDARIES OF PROPOSED EXTENTS OF ISS TREATMENT AREAS ARE IDENTIFIED BY AREA 500-1, 500-2, AND AREA 500-3.

ACRONYMS:

PPM PARTS PER MILLION

DATA REFERENCES:

SURVEY, SUBSURFACE, AND ANALYTICAL DATA COLLECTED AS PART OF THE REMEDIAL INVESTIGATION PERFORMED BY CDM SMITH, JUNE 23, 2016.

Appendix A

Interim Action Work Plan, USG Highway 99 Site
Contaminated Creek Sediment Removal and Parcel
P429 Plus Soil Excavation

Puget Sound GATEWAY Program

509



167

SR 167/I-5 to SR 509 – New Expressway

USG Highway 99 Site, Hylebos Creek Contaminated Sediment Removal and Parcel P429 Plus Soil Excavation

Interim Action Work Plan

September 15, 2021

Prepared for:
Washington State Department of Transportation
Megaprograms
Puget Sound Gateway Program | SR 167 Completion Project

Through:
WSP USA
1001 Fourth Avenue, Suite 3100 | Seattle, WA

Prepared by:
Innovex Environmental Management, Inc.
Redmond, Washington



Revision History

Date	Revision
9/4/2020	Revision 0 – Draft for Internal Review
10/15/2020	Revision 1 – Draft for WSDOT Review
02/10/2021	Revision 2 – Draft updated to include soil removal
03/19/2021	Revision 3 – Draft updated to address review comments
3/30/2021	Revision 4 – Draft updated to address technical edit and additional review comments
4/15/2021	Revision 5 – Draft updated to address technical edit and additional review comments
7/9/2021	Revision 6 – Document retitled Interim Action Work Plan
8/4/2021	Revision 7 - Address Ecology & USG/CDM comments, expand soil excavation area
9/8/2021	Revision 8 – Incorporate additional comments from Ecology and USG
9/14/2021	Revision 9 - Final



Certification

The technical material and data contained in this document were prepared under the supervision and direction of the undersigned.

Anna J Jordan

Prepared by Anna Jordan, LG

Glenn A. Hayman

Approved by Glenn A. Hayman, LHg

Table of Contents

1.0	Executive Summary	1
2.0	Introduction	2
2.1	Authorization	3
2.2	Purpose.....	3
2.3	Previous Studies	3
2.4	Regulatory Framework.....	4
2.4.1	Applicable Laws and Regulations.....	4
2.4.2	Applicable, Relevant, and Appropriate Requirements.....	5
3.0	Site Description	6
3.1	Site History.....	6
3.2	Site Geology and Hydrogeology	7
3.2.1	Site Geologic Conditions	8
3.2.2	Site Hydrogeologic Conditions	8
3.2.3	Groundwater/Surface Water Interaction.....	9
3.3	Nature and Extent of Contamination	9
3.3.1	Distribution of Arsenic in Soil.....	9
3.3.2	Distribution of Arsenic in Groundwater	9
3.3.3	Distribution of Arsenic in Sediment	10
3.4	Human Health and Environmental Concerns.....	10
3.4.1	Soil.....	10
3.4.2	Groundwater.....	10
3.4.3	Sediment	10
3.4.4	Summary	11
3.5	Cleanup Standards	11
3.5.1	Contaminants of Concern.....	11
3.5.2	Remedial Goals and Objectives	11
3.5.3	Cleanup Levels.....	12
4.0	Description of the Selected Remedy	12
4.1	Sediment Removal.....	12
4.2	P429 Plus Soil Excavation	13
4.3	Plans	14
4.3.1	Compliance Monitoring Plans.....	14
4.3.2	Disposal and/or Treatment Plan.....	15
4.4	Implementation and Documentation	16

4.5	Schedule for Implementation	17
4.6	Institutional/Engineering Controls	17
4.7	Public Participation.....	18
5.0	Limitations.....	18
6.0	References	18

Appendices

Appendix A – Abbreviations

Appendix B – Site Location Map

Appendix C – Site Features Map

Appendix D – Groundwater Elevation Contour Map

Appendix E – Map of Arsenic Contamination in Soil

Appendix F – Map of Arsenic Contamination in Groundwater

Appendix G – Conceptual Site Plan

Appendix H – Representative Cross Sections

Appendix I – Wells to be Decommissioned

1.0 Executive Summary

This document presents the Interim Action Work Plan (IAWP) for a portion of the USG Interiors Inc. (USG) Highway 99 site (Site) located at approximately 7110 Highway 99, Milton, Washington, where contamination will be encountered during the construction of the SR 167/I-5 to SR 509 – New Expressway Stage 1b project (Project). The IAWP presented in this document is limited to:

- The focused removal of the contaminated sediment and a limited amount of streambank soil in the existing Hylebos Creek channel.
- The excavation and disposal of contaminated soil to create a new, relocated Hylebos Creek channel.
- The excavation and disposal of contaminated soil on parcel P429 and the adjacent proposed future right-of-way (ROW) between P429 and Highway 99. Parcel P429 and the adjacent proposed future ROW between P429 and Highway 99 is referred to as P429 Plus throughout this document.
- Installation of a low permeability soil barrier (LPSB) in the sediment removal and soil excavation areas to prevent recontamination of these areas by the infiltration of arsenic contaminated groundwater.

The Interim Actions (IAs) described in Section 4.0 of this IAWP will remove and contain arsenic contaminated sediment, soil, and groundwater. The actions are consistent with the Model Toxics Control Act (MTCA), Washington Administrative Code (WAC) Chapter 173-340. The IAWP will be implemented by Washington Department of Transportation's (WSDOT's) Design-Builder as part of the construction of the Project.

Historical records show that fill was imported to bring the Site up to grade with Highway 99. This fill included industrial waste from USG's Tacoma, Washington plant. From 1959 through 1973, the USG Tacoma plant used ASARCO slag as a raw material for mineral fiber production. The ASARCO copper smelter operated at nearby Ruston, Washington, from 1890 to 1986. ASARCO's copper smelting process concentrated arsenic in the slag. Baghouse dust and off-specification product from USG's Tacoma plant were reportedly used as fill at the Site from 1971 through 1973 (Ecology, 1986). In 1985 a partial cleanup was completed by USG. An estimated 20,000 to 30,000 cubic yards of material was excavated and disposed of offsite (Ecology, 1986). These activities have led to present day sediment, soil, and shallow groundwater arsenic contamination on Site.

Construction of the new Hylebos Creek channel will result in the excavation of arsenic-contaminated sediment and soil. The new stream channel will include a LPSB to prevent the flow of contaminated groundwater into Hylebos Creek as shown in Appendix H.

Additionally, soil on property P429 Plus with an arsenic concentration greater than the MTCA Method A Soil cleanup level (CUL) of 20 mg/kg will be excavated and disposed of off-site.

WSDOT will implement this IAWP to protect human health and the environment. Following completion of the sediment removal, soil excavation, and site restoration, Ecology may apply a parcel restriction document (PRD) to the excavation area.

2.0 Introduction

This IAWP has been prepared by INNOVEX on behalf of WSDOT for a portion of the USG Highway 99 site (Site) located at approximately 7110 Highway 99, Milton, Washington where contamination will be encountered during the construction of the Project. The IAWP presented in this document is limited to:

- The removal of the contaminated sediment and limited streambank soil in the existing Hylebos Creek channel;
- The excavation and disposal of contaminated soil to create a new, relocated Hylebos Creek channel;
- Excavation and disposal of arsenic contaminated soil on WSDOT property P429 Plus; and
- Construction of a LPSB to prevent recontamination of these areas by the infiltration of arsenic contaminated groundwater.

WSDOT's Project requires relocation of Hylebos Creek into a new stream channel. It is this work that in part results in the need to perform excavation in the existing contaminated stream channel. In addition, construction of the new Hylebos channel will require excavation of contaminated soil. WSDOT has coordinated with USG and Ecology on this work element. WSDOT is undertaking IAs to protect human health and the environment, and to minimize the risks to the Project associated with the contamination originating from the Site.

The Site location is shown in Appendix B. The Site features map is shown in Appendix C. This IAWP has been prepared to meet the requirements of MTCA as administered by Ecology.

This IAWP describes the Site, the nature and extent of contamination, and the proposed IAs for the removal of sediment in the existing Hylebos Creek channel, the soil to be excavated for the new Hylebos Creek channel and on P429 Plus with arsenic concentrations above the applicable MTCA CULs. The IAWP shall be implemented by the Design-Builder as part of the construction of the Project.

This IAWP is based on the work conducted by USG for the Site under Ecology supervision. Reports documenting much of the work are available on Ecology's website (<https://apps.ecology.wa.gov/gsp/CleanupSiteDocuments.aspx?csid=3618>). This IAWP is part of the work that will be conducted for the USG Site under Ecology supervision.

2.1 Authorization

Preparation of this document was conducted under Master Subconsultant Agreement Y-11918, Task Order BO.

2.2 Purpose

This document is an IAWP for a portion of the Site and outlines:

- The removal of contaminated sediment in and adjacent to Hylebos Creek;
- The excavation of contaminated soil to create a new channel for Hylebos Creek; and
- The excavation of soils from WSDOT property referred to as P429 Plus within the Site with an arsenic concentration greater than the MTCA Method A Soil CUL for unrestricted land use of 20 mg/kg.

An interim action is allowed as part of the cleanup process under Chapter 173-340 WAC. The primary purpose of this IAWP is to identify the proposed IAs for the contaminated sediment and the soil on the Site identified above. This IAWP is subject to public review. More specifically, this plan:

- Describes the portion of the Site as it pertains to this work;
- Summarizes current Site conditions for the portion of the site associated with this work;
- Describes the selected IAs for the removal of contaminated sediment and excavation of contaminated soil from a portion of the Site and the rationale for selecting this alternative;
- Identifies the monitoring requirements;
- Identifies applicable state and federal laws for the proposed IA;
- Discusses compliance monitoring requirements; and
- Presents the schedule for implementing the IAWP.

2.3 Previous Studies

Previous work conducted by USG at the Site to meet the requirements of several agreed orders with Ecology include a remedial investigation (RI) and feasibility study (FS), the results of which are presented in the RI Report dated June 23, 2016 (CDM Smith Inc., 2016); the FS Report dated June 23, 2016 (CDM Smith Inc., 2016a), a field pilot study (CDM Smith Inc., 2020) and a conceptual design (CDM Smith Inc., 2020a). Currently, Agreed Order No. DE-11099 is in effect.

The FS Report contains a detailed screening and evaluation of technologies to address arsenic contamination at the Site. Ecology determined that the screening of technologies was adequate to develop specific cleanup alternatives for the Site. The alternatives evaluated for the Site included the following:

- Alternative 1 – Chemical Stabilization of Hot Spot Soil, In-Situ Chemical Oxidation (ISCO) of Groundwater, permeable pavement, Monitored Natural Attenuation (MNA), Institutional Controls, Sediment Excavation
- Alternative 2 – In-situ soil solidification (ISS) of Hot Spot Soil, ISCO of Groundwater, permeable pavement, MNA, Institutional Controls, Sediment Excavation
- Alternative 3 – ISS of Hot Spot Soil, Extraction and Treatment of Hot Spot Groundwater, ISCO of Groundwater, Permeable Reactive Barrier and Slurry/Sheet Pile Wall, permeable pavement, MNA, Institutional Controls, Sediment Excavation
- Alternative 4 – Soil Excavation and Off-site Disposal, Groundwater Extraction and Treatment, permeable pavement, MNA, Institutional Controls, Sediment Excavation

The cleanup action alternatives were screened against the MTCA threshold criteria for selection of cleanup actions (WAC 173-340-360) that include protection of human health and the environment, compliance with cleanup standards, compliance with applicable state and federal laws, and provisions for compliance monitoring. The evaluation of cleanup action alternatives also considered future development plans for the Site and the potential adverse impacts on Hylebos Creek.

Alternative 2 was the selected alternative. Subsequently, an ISCO pilot study was conducted and yielded unfavorable results (CDM Smith Inc., 2020). Modelling was then completed to refine USG's understanding of the conceptual site model, and to evaluate implementing ISS over a larger area and in the saturated zone (CDM Smith Inc., 2020a).

2.4 Regulatory Framework

This section describes the applicable laws and regulations for the IA.

2.4.1 Applicable Laws and Regulations

Applicable laws and regulations provide the framework for this interim remedial action. WAC 173-340-430 provides for interim remedial actions. WAC 173-340-360(2) and 173-340-710(1)(a) require that interim actions conducted under MTCA comply with applicable federal and state laws. Applicable laws are defined as those requirements that are legally applicable, as well as those that Ecology determines to be both relevant and appropriate.

2.4.2 Applicable, Relevant, and Appropriate Requirements

The applicable laws and regulations for the IAs include, but are not limited to, the following:

Federal Applicable, Relevant, and Appropriate Requirements (ARARs)

- The Clean Water Act (33 U.S. Code [USC] 1251 et seq.)
- National Toxics Rule (40 Code of Federal Regulations [CFR] 131.36 et seq.)
- Comprehensive Environmental Response, Compensation, and Liability Act of 1980 (42 USC 9601 et seq. and 40 CFR 300)
- Resources Conservation and Recovery Act (40 CFR Parts 261, 265, 268, 270, and 271)
- Endangered Species Act (16 USC § 1531 et seq.)
- Native American Graves Protection and Repatriation Act (25 USC 3001 through 3113; 43 CFR Part 10)
- Archaeological Resources Protection Act (16 USC 470aa et seq.; 43 CFR Part 7)
- National Historic Preservation Act (16 USC 470 et seq.; 36 CFR Parts 60, 63, and 800)

State ARARs

- MTCA (Revised Code of Washington [RCW] 70A.305)
- MTCA Cleanup Regulations (Chapter 173-340 WAC)
- Sediment Management Standards (WAC 173-204)
- Washington State Environmental Policy Act (RCW 43.21)
- Water Quality Standards for Washington Surface Waters (Chapter 173-201A WAC)
- Washington State Shoreline Management Act (RCW 90.58, Chapter 173-18 WAC, Chapter 173-22 WAC, and Chapter 173-27 WAC)
- Washington Underground Injection Control Program (Chapter 173-218 WAC)
- Washington State Hydraulics Projects Approval (RCW 77.55; Chapter 220-110 WAC)
- Washington State Solid Waste Handling Standards, (Chapter 173-350 WAC)
- Washington Dangerous Waste Regulations (Chapter 173-303 WAC)

- Washington’s Indian Graves and Records Law (RCW 27.44); Archaeological Site Assessment Requirements (RCW 27.44 and 27.53)
- State of Washington Worker Safety Regulations

3.0 Site Description

This section provides a description of the Site to provide the Design-Builder an inclusive understanding of Site conditions. The Site is located between Highway 99 and I-5 in Milton, Washington, within a commercial area situated on the east side of Highway 99 (Appendix B and C). The areas of the Site of interest for this IAWP are:

- the contaminated sediment in the existing Hylebos Creek, and
- the contaminated soil on P429 Plus as shown in Appendix G.

Four principal businesses operate on the Site: Freeway Trailer, Kanopy Kingdom, General Trailer, and Linwood Custom Homes (Appendix C). The northern property boundary of Linwood Custom Homes marks the northern end of the Site. The western edge of the Site is the boundary between these businesses and Highway 99. I-5 marks the eastern boundary of the Site. Hylebos Creek and 70th Avenue East mark the southern boundary of the Site. The western portion of the Site is paved and relatively flat, but drops off sharply east of the paved area where the surface slopes down either to Hylebos Creek or Stream 4. The central portion of the Site is located at an elevation of approximately 20 feet above mean sea level.

3.1 Site History

The historical description that follows is based on an interpretation of historical aerial photographs, documents from Ecology, and a title search (Ecology, 2014).

Fill was imported to bring the Site up to grade with Highway 99. This fill included industrial waste from USG’s Tacoma, Washington plant. From 1959 through 1973, the USG Tacoma plant used ASARCO slag as a raw material for mineral fiber production. The ASARCO copper smelter operated at nearby Ruston, Washington, from 1890 to 1986. ASARCO’s copper smelting process concentrated arsenic in the slag. Baghouse dust and off-specification product from the USG Tacoma plant were reportedly used as fill at the Site from 1971 through 1973 (Ecology, 1986). USG did not own the property during the period when this fill was placed.

In the early 1980s, USG became aware of the association between ASARCO slag and arsenic contamination. Subsequently, USG purchased what is now the Kanopy Kingdom property from Partner’s Financial Incorporated on August 18, 1982. That same year, USG voluntarily approached Ecology to negotiate an administrative process to govern the removal of industrial waste fill from the property. Soil and groundwater cleanup standards had not been established in the State of Washington at this time. Accordingly, Agreed Order No. DE 84-506 established project-specific arsenic cleanup standards for soil (0.5

milligrams per liter [mg/l]) by the Extraction Procedure Toxicity (leaching) method and for groundwater (0.5 mg/l). The 1984 Order also required USG to conduct post-cleanup groundwater monitoring.

Partial cleanup of the Highway 99 Site occurred between October 12, 1984 and January 25, 1985 (Ecology, 1986). Detailed records of the cleanup, referred to as the *source removal action*, have not been located. Ecology estimated that 20,000 to 30,000 cubic yards of material was excavated and disposed of off-site (Ecology, 1986). Native soil exceeding the Project-specific cleanup standard was reportedly excavated in the southern portion of the property in the vicinity of monitoring well 99-1 (Appendix E). Ecology (1986) stated that the Agreed Order soil cleanup standard of 0.5 mg/l for the project was met.

According to Ecology, approximately 10 percent of the total waste that was excavated and disposed off-site was baghouse dust. It is inferred that the 20,000 to 30,000 cubic yards of waste included soil fill mixed with waste insulation, baghouse dust, and native soil exceeding the cleanup standard was excavated from the Kanopy Kingdom property.

A review of historical aerial photographs shows that the property was cleared and regraded in June 1985 (approximately five months after completion of the source removal action). The Site subsequently underwent commercial development and by 1989 had been developed to its current configuration. USG maintained responsibility for verification monitoring, as specified in Agreed Order No. DE 87-506 issued in 1987. The 1987 Order retained the 0.5 mg/l groundwater CUL for the Site. Post-source removal action verification groundwater sampling was performed by USG from June 1985 to April 2006.

MTCA was enacted and went into effect in March 1989. MTCA governs state-led environmental cleanups in Washington State. In 1991, Ecology established MTCA Method A arsenic CULs of 20 milligrams per kilogram (mg/kg) for soil for unrestricted land use and 5 micrograms per liter ($\mu\text{g/l}$) for groundwater.

In 2006, Ecology required that USG conduct a soil and groundwater assessment for arsenic in the vicinity of well 99-1. This assessment showed that arsenic in soil and groundwater exceeded MTCA Method A CULs. On March 30, 2007, Ecology sent USG a letter naming USG as a potentially liable party for the release of arsenic at the Highway 99 Site. This led to issuance of the current Agreed Order number DE 11099 in 2016.

As described in Section 2.3, USG is planning to implement an ISS in the arsenic source area on parcels P430 and P431 that will mitigate the leaching of arsenic into groundwater (CDM Smith Inc., 2020). This USG action is planned to be completed by September 2022. It is anticipated that a finite quantity of contaminated groundwater will remain.

3.2 Site Geology and Hydrogeology

The Site geology and hydrogeology described below is summarized from the RI Report (CDM Smith Inc., 2016).

3.2.1 Site Geologic Conditions

The Site is situated in a north-trending valley that is in the floodplain of Hylebos Creek and its tributaries. The valley is located just north of the lower Puyallup River valley. Alluvium associated with Hylebos Creek and the lower Puyallup River forms the uppermost native soil at the Site. The alluvium consists predominantly of overbank flood, slack water, and bar accretion deposits. Consolidated glacial drift and interglacial deposits hundreds to thousands of feet thick underlie the alluvial deposits. Fife Heights, the upland region northwest of the property, is largely comprised of glacial drift.

Generalized stratigraphy consists of fill overlying alluvium over glacial drift. Each of these units is described in more detail in the RI (CDM Smith, Inc, 2016).

3.2.2 Site Hydrogeologic Conditions

3.2.2.1 Alluvial Aquifer

Groundwater occurs under unconfined conditions within sand and silty sand of the Alluvial Aquifer. The low permeability soil of the Lower Silt Aquitard acts as a lower confining layer to the Alluvial Aquifer, restricting vertical flow. During the RI, groundwater was encountered at depths ranging from 4 to 14 feet bgs.

A groundwater elevation contour map for the Alluvial Aquifer, based on the July 15, 2010, depth-to-groundwater measurements, and monitoring well locations are shown in Appendix D. The contours indicate that groundwater flows east toward Hylebos Creek and south parallel to the creek. The horizontal hydraulic gradient ranges from 0.003 foot/foot in the central area of the Site, steepening to 0.03 foot/foot at the west bank of Hylebos Creek (CDM Smith, Inc., 2016).

The vertical hydraulic gradient within the Alluvial Aquifer was calculated at the MW-5/MW-8 and well 99-1/MW-7 well pairs. Wells in these pairs are completed within the shallow and deeper portions of the Alluvial Aquifer. The results of the vertical hydraulic gradient calculations indicate upward vertical hydraulic gradients ranging from 0.022 to 0.035 foot/foot, based on the July 15, 2010, groundwater elevation measurements. The upward gradient indicates potential for upward groundwater flow (CDM Smith, Inc., 2016).

The RI (CDM Smith, Inc., 2016) identified the predominant soil types in the Alluvial Aquifer are fine-grained silty sand (SM) and sand (SP). The hydraulic conductivity of these soils ranges from 0.3 to 30 feet/day, based on literature-derived hydraulic conductivity values for silty sand and fine sand. Layers of coarser-grained sands (SP and SW) are also present within the Alluvial Aquifer. These sands have hydraulic conductivities ranging from 130 to 200 feet/day.

3.2.2.2 Glacial Aquifer

The head differential between well pairs screened within the Alluvial Aquifer and the Glacial Aquifer (well 99-1 and MW-9, respectively) was 6.58 feet based on the July 15,

2010 measurements. This large head differential indicates that the Glacial Aquifer is confined and exerting considerable hydraulic pressure on the overlying Lower Silt Aquitard. The different hydraulic and geochemical characteristics of the Glacial Aquifer and the Alluvial Aquifer indicate that the two aquifers are not in hydraulic communication.

The Glacial Aquifer is comprised of soil types ranging from silty sand (SM) to silty gravel (GM). Based on these soil types, the seepage velocity in the Glacial Aquifer is estimated to range from as low as 20 feet/day to as high as 70,000 feet/day. Typical hydraulic conductivity values for glacial aquifers in the Site vicinity are at the lower end of this range.

3.2.3 Groundwater/Surface Water Interaction

The nature of interaction between the Alluvial Aquifer and Hylebos Creek is difficult to characterize because of the 1961 relocation of Hylebos Creek during construction of I-5 into its current channelized section. The base of the channelized section adjacent to the contaminant source area intersects the Alluvial Aquifer. Alluvial Aquifer groundwater table contours bend sharply adjacent to Hylebos Creek, indicating the Alluvial Aquifer does flow into Hylebos Creek (Appendix D). However, the very steep Alluvial Aquifer gradient of 0.03 foot/foot at the west bank of Hylebos Creek indicates there is a weak hydraulic connection between the Alluvial Aquifer and Hylebos Creek adjacent to the contaminant source area. This channelized section of Hylebos Creek does not appear to function as a true groundwater discharge area that would be found in an unconfined aquifer and an unmodified stream.

3.3 Nature and Extent of Contamination

The nature and extent of contamination described below is summarized from the RI Report (CDM Smith Inc., 2016).

3.3.1 Distribution of Arsenic in Soil

Soil with arsenic concentrations above the MTCA Method A CUL are shown in Appendices E, G, and H. These appendices were created using the Leapfrog model developed by CDM and provided by USG. Based on the model output, contaminated soil to be removed is at depths of less than 20 feet below ground surface (bgs). On P429 Plus there are two small areas of soil with arsenic concentrations greater than 500 mg/kg that are 12 feet or less bgs.

3.3.2 Distribution of Arsenic in Groundwater

The distribution of dissolved arsenic in groundwater at the Site is shown in Appendix F. The RI documented the highest concentrations of arsenic in groundwater are on property P430. Arsenic concentrations in all Site Alluvial Aquifer monitoring wells exceed the MTCA Method A CUL of 5 µg/l, including the MW-13 (south of the soil excavation area). Elevated arsenic concentrations extend east of Hylebos Creek. MW-10, located east of Hylebos Creek, had a dissolved arsenic concentration of 366 µg/l.

Monitoring wells MW-5, MW-6, and MW-8 are located on property P429 Plus. Dissolved arsenic concentrations in samples collected from these wells in May 2010 were 1,090 ug/L, 310, ug/L, and 13 ug/L respectively. These are the most recent groundwater samples collected and analyzed from these wells.

3.3.3 Distribution of Arsenic in Sediment

As part of the RI, CDM Smith collected and analyzed 14 Hylebos Creek sediment samples from the center and south bank of Hylebos Creek. The depth of the samples is identified as surface. The samples were analyzed for total arsenic. Six of these samples had arsenic concentrations greater than the sediment CUL of 14 mg/kg. These sample locations are downgradient of where the highest concentrations of arsenic were detected in groundwater, indicating that the elevated arsenic in sediment is the result of arsenic-impacted groundwater discharging into to Hylebos Creek (CDM Smith, Inc., 2016). The area defined by these samples is shown in Appendix G. This is the area where the IAs described in this IAWP shall be completed for the contaminated sediment and limited streambank soil in the existing creek channel associated with the Site.

3.4 Human Health and Environmental Concerns

3.4.1 Soil

Soil sample analytical data indicate that the soil with arsenic concentrations greater than 20 mg/kg and soil hot spots with greater than 500 mg/kg remain on P429 Plus. These areas are largely capped with pavement limiting exposure. Construction of the Project will result in the removal of the pavement, increasing the potential exposure. Excavation and disposal of the contaminated soil will minimize the risk.

3.4.2 Groundwater

In the area of the IAs, groundwater is nine to ten feet bgs (see Appendix H) and is contaminated with arsenic. The source of the contamination is located up gradient of the IAs on properties P430 and P431. Installation of a LPSB is intended to contain contaminated groundwater outside the IAs area. USG's planned ISS cleanup action on these two properties is intended to contain the contaminant source.

Contaminated groundwater in the Alluvial Aquifer does not pose an imminent threat to human health via the drinking water pathway. Water supply for the Site and surrounding area is supplied by deep groundwater supply wells hydraulically separated from the Alluvial Aquifer.

3.4.3 Sediment

Shallow groundwater at the Site discharges into Hylebos Creek adjacent to the Site. Sediment samples collected from the bank and center of Hylebos Creek show elevated arsenic concentrations downgradient of where the highest concentrations of arsenic were detected in groundwater on P430 and P431. This indicates that dissolved arsenic in

groundwater is either adsorbing onto sediment or coprecipitating with iron onto sediment at the groundwater/surface water interface (CDM Smith, Inc., 2016). The approximate area of contaminated sediment is shown in Appendix G (CDM Smith, Inc., 2016a).

3.4.4 Summary

The principal threat to receptors is posed by residual arsenic in soil leaching to groundwater and dissolved arsenic in groundwater. Dissolved arsenic is then transported via the groundwater pathway to Hylebos Creek surface water and sediment.

3.5 Cleanup Standards

3.5.1 Contaminants of Concern

Arsenic contaminated sediment in the existing creek channel associated with the Site, and arsenic contaminated soil on property P429 Plus are the media of concern for this IA.

The results of the RI (CDM Smith, Inc., 2016) indicate that dissolved arsenic in shallow groundwater at the Site is discharging to Hylebos Creek and adsorbing onto sediment or coprecipitating with iron onto sediment at the groundwater/surface water interface resulting in the contaminated sediment and creek bank soils.

The RI also documents arsenic contaminated soil on P429 Plus.

Contaminated soil west of the proposed future ROW, and on properties P430 and P431 are beyond the scope of this IAWP and will be left in place.

3.5.2 Remedial Goals and Objectives

The overall goals for the proposed IAs at this site are to:

- Protect human health and the environment;
- Comply with applicable regulations;
- Remove or contain impacted sediment to protect ecological receptors;
- Profile and dispose of contaminated sediment;
- Excavate soil from P429 Plus with arsenic concentrations greater than 20 mg/kg;
- Profile and dispose of contaminated soil at a Title C or Title D landfill; and
- Recover, treat, and discharge or dispose of contaminated groundwater as necessary to complete the IAs.

3.5.3 Cleanup Levels

CULs are the concentrations of the contaminants of concern that will be met for the media of concern at the points of compliance defined for the Site to meet the requirements of MTCA. The contaminant of concern at the Site is arsenic. The arsenic CULs for the Site as established in the Draft Cleanup Action Plan (Ecology, 2014) are indicated in the table below.

Media	Basis	Cleanup Level
Soil	MTCA Method A	20 mg/kg ¹
Groundwater	MTCA Method A	5 µg/l
Sediment	WAC 173-204 ²	14 mg/kg

¹ MTCA CUL for Unrestricted Land Use

² The freshwater sediment CUL is the concentration that no adverse effects are expected to the benthic community.

4.0 Description of the Selected Remedy

USG and WSDOT are negotiating an agreement to provide USG and their representative(s) with access to the IAs area to observe field activities, conduct field screening, and collect samples for analysis. The Design-Builder shall provide access to the Project area for Ecology, USG and their representatives as directed by the WSDOT Engineer. As the agency with regulatory authority for the IAs, Ecology will have access to the Site to conduct necessary activities. USG and Ecology will be required to comply with Project training requirements and safety protocols.

4.1 Sediment Removal

The arsenic-contaminated sediment within the existing Hylebos Creek shall be cleaned up by excavation, off-site disposal, and capping with a LPSB. This excavation and disposal remedy was evaluated in the Site FS (CDM Smith Inc., 2016a). It is the selected remedy in the Draft Cleanup Action Plan (Ecology, 2014). Addition of the LPSB to the remedy provides long term containment and protection from recontamination. See Appendix G for the Conceptual Site Plan for the sediment and streambank removal in the existing Hylebos Creek and the new stream channel being created by the Project. Excavation and disposal of contaminated soil on P429 Plus further protects the environment from Site contaminants.

The sediment removal in the existing Hylebos Creek channel remedial approach includes the following: constructing coffer dams at both ends of the impacted section of Hylebos Creek; pumping or gravity flow the stream water around the coffer dams; excavating from the bottom of the stream up to two-feet of soil and sediment with arsenic above CULs; disposing of it off-site; and installing a two-foot thick LPSB in the bottom of the stream channel. In addition, on the western stream bank to an elevation of 15 feet above mean sea level, excavate one-foot of soil and replace it with a LPSB. The LPSBs are to minimize

subsequent recontamination of the stream channel by groundwater seepage. See Appendices G and H for the conceptual design. The LPSB shall consist of compacted earthen material with permeability $<1 \times 10^{-7}$ centimeters/second (cm/sec). It can be locally available clay or created by mixing bentonite with soil. Excavated sediment will be stockpiled in the containment bays assembled by the Design-Builder and described in Section 4.3.2 below.

From a MTCA interim action perspective, no contingencies for sediment remediation are considered necessary at this time. Any additional sediment remediation, characterization, and monitoring is beyond the scope of this IAWP.

Allowance for differences in quantities encountered during construction are addressed in the Design-Builders contract with WSDOT.

4.2 P429 Plus Soil Excavation

Construction of the new Hylebos Creek channel will result in the excavation of arsenic-contaminated soil on property P429 Plus. All the soil within the new creek channel with an arsenic concentration greater than the MTCA Method A CUL for unrestricted land use, 20 mg/kg, shall be excavated stockpiled in containment bays (see Section 4.3.2), and disposed by the Design-Builder. The bottom, north sidewall and west sidewall of the excavation will be lined with a LPSB as shown in Appendix H. The LPSB will minimize the unimpeded flow of contaminated groundwater onto P429 Plus and into Hylebos Creek. Due to the potential for higher flow rates in the new Hylebos Creek, the finished channel will also include erosion control riprap, and streambed sediment. See Cross Section A in Appendix H.

In addition to excavation of the new Hylebos Creek channel on P429 Plus, soil with an arsenic concentration in excess of the MTCA Method A soil CUL for unrestricted land use of 20 mg/kg shall be excavated, stockpiled, and disposed. Overburden soil with an arsenic concentration less than 20 mg/kg will be stockpiled and used to backfill the excavation above the water table where it is the greatest distance from the new and existing Hylebos Creek channel. Excavation backfill will be compacted per Project specifications.

The volume of arsenic contaminated soil on P429 Plus has been estimated with a computer model (Leapfrog) prepared by CDM Smith for USG. These volumes are approximate, are subject to the inaccuracies inherent in computer model estimates, and the heterogeneous distribution of contaminants in soil. These volumes have already been increased by 25% above the computer model to account for the inaccuracies due to spacing of the soil tests and the reality that the sidewalls of the excavation are not likely to be vertical. Actual excavated soil volumes will likely vary from these estimates and will be determined during implementation of this IAWP. The estimated P429 Plus contaminated soil volumes are:

- Arsenic >500 mg/kg - 18 cubic yards (CY);
- Arsenic <500 mg/kg and > 90 mg/kg - 820 CY; and

- Arsenic <90 mg/kg and >20 mg/kg – 4,500 CY.

The less than 20 mg/kg arsenic overburden soil volume is estimate to be 1,370 CY.

There are three groundwater monitoring wells on P429 Plus, MW-5, MW-6, and MW-8. Well logs and construction details are provided in Appendix I. These wells shall be decommissioned by the Design-Builder.

4.3 Plans

The Design-Builder shall prepare a detailed plan to implement this IAWP. Throughout the implementation of this IAWP, water quality must meet the criteria of the NPDES Construction Stormwater General Permit, and/or Section 401 Water Quality Certification, or other regulatory requirement(s) as applicable.

The Design-Builder shall prepare the construction plans and specifications that will detail the IAs to be performed in accordance with WAC 173-340-400. These documents will be subject to review and approval by Ecology and WSDOT. The Design-Builder is to assume a review period of 30 calendar days for Ecology on both draft and final versions of the documents. As required by WAC 173-340-400(4)(b), the plans shall include the following information, as applicable:

- A description of the work to be performed;
- A Site location map and a map of existing conditions;
- A copy of applicable permit applications and approvals;
- Detailed plans, procedures, and specifications necessary for the IA; and
- Specific quality control tests to be performed to document the construction, including specifications for the testing or reference to specific testing methods, frequency of testing.

All IAWP related cleanup activities shall be conducted consistent with the Section 401 Water Quality Certification, and Section 402 NPDES Construction Stormwater General Permit and consistent with Water Quality Standard thresholds of WAC 173-201A for the Project.

4.3.1 Compliance Monitoring Plans

Compliance Monitoring Plans shall be prepared and implemented by the Design-Builder. Monitoring of the IAs shall be performed in accordance with the requirements of WAC 173-340-410. The compliance monitoring plan shall describe monitoring to be performed during construction, and a sampling and analysis plan meeting the requirements of WAC 173-340-820.

4.3.1.1 Performance Monitoring

Performance monitoring samples for sediment removal in the existing Hylebos Creek channel shall be collected and analyzed by the Design-Builder when field screening indicates that no more contamination is present. Based on the Leapfrog model, this is a maximum of approximately two feet below the current bottom of the channel. Laboratory reports shall be sent to WSDOT who will forward them to Ecology for review. Ecology will review the reports and provide timely acceptance or denial of the termination of sediment removal based on sample analytical results.

Performance monitoring samples for the P429 Plus contaminated soil excavation shall be collected from the bottom and sidewalls of the excavation. The Design-Builder shall document that the arsenic soil concentrations on P429 Plus are in compliance with the MTCA Method A Soil CUL of 20 mg/kg. The north and west sidewalls of the excavation will be at the property lines and are considered to be outside the IA. Samples from these sidewalls do not need to comply with the 20 mg/kg CUL.

4.3.1.2 Protection Monitoring

Protection monitoring shall be conducted by the Design-Builder during the IA construction to confirm that human health and the environment are protected consistent with the health and safety requirements of WAC 173-340-810. The frequency, scope, and duration of monitoring and sampling shall be detailed in the Design-Builder's Protection Monitoring Plan. Monitoring shall be conducted to ensure workers are protected during the IA.

4.3.2 Disposal and/or Treatment Plan

The Design-Builder shall prepare a detailed plan identifying how contaminated water, soil, and sediment shall be stored, treated, and disposed. The plan shall include copies of the permits for all proposed disposal or treatment facilities.

Dewatering is anticipated to be required to implement this IAWP. The Design-Builder shall be responsible for permitting, treatment and discharge or disposal of this water. Water may be treated and discharged to surface water. Note that there are a several surface water criteria listed in Ecology's CLARC table

https://www.ezview.wa.gov/Portals/1987/Documents/Documents/CLARC_Master.xlsx

that could apply to this discharge including;

- 0.018 µg/l protective of human health;
- 190 µg/l chronic exposure protective of fresh water aquatic life; and
- 340 µg/l acute exposure protective of fresh water aquatic life.

Treatment and discharge to the sanitary sewer is another potential option. The current arsenic discharge criteria for the sanitary sewer serving the area is 230 µg/l.

Prior to initiating the sediment removal and contaminated soil excavation activities described in this IAWP, the Design-Builder shall assemble lined containment bays on P429 Plus or other appropriate WSDOT properties within the Project area. The bays shall have sufficient capacity to contain the removed sediment and excavated soil generated by the IAs and will be used to stockpile these materials prior to disposal. The Design-Builder shall be responsible for subsequent testing and disposal of the stockpiled material. Operation of the containment bays shall be conducted in compliance with applicable permits and best management practices. Water quality consistent with NPDES Construction Stormwater General Permit and/or Section 401 Water Quality Certification, as applicable, shall be maintained throughout the operation of the containment bays and implementation the IAs.

The majority of the excavated soil and sediment is anticipated to be compatible with disposal at a subtitle D landfill, such as LRI in Puyallup, Washington. A limited volume of soil is anticipated to require disposal at the subtitle C landfill, such as Chemical Waste Management's landfill in Arlington, Oregon.

4.4 Implementation and Documentation

During the soil and sediment excavation activities, the Design-Builder's qualified environmental consultant shall field screen in-place and excavated soil and sediment with an x-ray fluorescence device to segregate soil based on arsenic concentration. From the completed excavations, the Design-Builder shall collect final grade samples as required by Ecology to document that the arsenic contaminated sediment and soil have been removed. The field screening and final grade samples analytical results shall be compiled and submitted to WSDOT. The Design-Builder shall provide WSDOT with real-time daily reports and up-to-date analytical reports. These reports will be forwarded to Ecology and USG. A WSDOT representative will be onsite conducting verification sampling. Representatives of Ecology and USG may be onsite as observers conducting field screening and collecting samples.

To support the anticipated long term groundwater monitoring and avoid disturbance of the riparian restoration planned for P429 Plus, the Design-Builder's qualified environmental consultant shall install and develop up to four 2-inch groundwater monitoring wells on P429 Plus at locations identified by USG and approved by Ecology. Because arsenic is the primary contaminant of concern for the USG Site, wells shall be sufficiently developed by the Design-Builder's qualified environmental consultant to produce groundwater samples with turbidity below 20 nephelometric turbidity units.

All aspects of construction shall be performed and documented in accordance with the Project Contract and WAC 173-340-400(6). These aspects include approval by Ecology of all of the plans listed above prior to commencement of work and oversight of construction by a Professional Engineer licensed in the State of Washington.

Following completion of construction, the Design-Builder shall provide WSDOT with a submittal that documents the IAs and includes the following:

- inspector daily reports, and
- the results of all:
 - field screening,
 - soil and water sampling,
 - X-ray florescence (XRF) and laboratory analysis, and
 - disposal documentation.

USG shall provide WSDOT with the following:

- inspector daily reports,
- the results of all field screening,
- soil and water sampling, and
- XRF and laboratory analysis.

WSDOT will prepare a Construction Completion Report that includes the above documents provided by the Design-Builder and USG. It will document the implementation of the IAWP and include an opinion of the WSDOT Engineer as to whether the cleanup was conducted in substantial compliance with this IAWP, and the construction plans and specifications. Draft and final copies of this report will be provided to Ecology and USG for review and comment.

4.5 Schedule for Implementation

The Design-Builder shall anticipate that up to one year may be needed for planning, design, review, and approval. The construction work shall be completed in one season. Regardless of the exact schedule, the IAs shall be completed consistent with the Project Endangered Species Act (ESA) requirements from the Federal Services that limits in water work in Hylebos Creek to occur between July 15 and August 31.

4.6 Institutional/Engineering Controls

Based on the existing characterization of the nature and extent of the Site contamination, the WSDOT IAs described in this work plan will remove contaminated sediment and cap the stream bottom and west bank to contain the migration of arsenic contamination. Additionally, implementation of this IAWP will excavate and remove arsenic contaminated soil from property P429 Plus, and line the excavation with a LPSB to protect the property from recontamination.

P429 Plus is within the I-5 ROW and as such has no tax parcel identification number. Ecology does not apply restrictive covenants to ROW properties; however, they may apply a parcel restriction document (PRD) on WSDOT ROW to achieve a similar result. The PRD may include requirements to restrict groundwater usage, to implement appropriate property management practices to control any risk of exposure to potentially contaminated groundwater, notice and access limitations, such as signage and fencing, and annotations on the property title identifying the potential for arsenic contaminated groundwater.

After excavating contaminated soil to create a new Hylebos Creek stream channel and the P429 Plus soil excavation, contaminated soil will remain outside the excavated areas. Institutional and engineering controls for these areas should be included in the revised CAP being prepared by USG.

4.7 Public Participation

This IAWP will be included as an attachment, such as an appendix, to a revised CAP being prepared by USG. The revised CAP will be subject to public review and comment.

In addition, WSDOT has a well-established and robust public participation program for the Project. The IAWP will be added to WSDOT's program.

5.0 Limitations

This IAWP is based on the Site conditions, data, and other information available as of the date of the plan, and the information herein are applicable only to the time frame in which the plan was prepared. Background information used to prepare this document including, but not limited to, Site plans and other data, is available on Ecology's website or has been furnished to INNOVEX by WSDOT. INNOVEX has relied on this information as furnished and is neither responsible for nor has confirmed the accuracy of this information.

6.0 References

CDM Smith Inc. 2016. Remedial Investigation Report, USG Interiors Highway 99 Site, Milton, Washington. June 23, 2016.

CDM Smith Inc. 2016a. Feasibility Study, USG Interiors Highway 99 Site, Milton, Washington. June 23, 2016.

CDM Smith Inc. 2020. Conceptual Design Report USG Interiors Highway 99 Site, Milton, Washington. April 16, 2020.

CDM Smith Inc. 2020. Field Pilot Study Evaluation Report USG Interiors Highway 99 Site, 7110 Pacific Highway East, Milton, Washington 98354, May 29, 2020

Washington State Department of Ecology (Ecology). 1986. Memorandum to the Project File. By Dominick Reale, Washington State Department of Ecology. June 30, 1986.



Washington State Department of Ecology (Ecology). 2014. Draft Cleanup Action Plan, USG Interiors Highway 99 Site, Milton, Washington. April 24, 2014.

APPENDIX A

ABBREVIATIONS

µg/l – micrograms per liter
ARAR – applicable, relevant, and appropriate requirements
ASARCO – American Smelting and Refining Company
bgs – below ground surface
CFR – Code of Federal Regulations
cm/sec – centimeter per second
CSID – cleanup site ID
CUL – cleanup level
cy – cubic yards
Design-Builder – WSDOT’s Contractor for the Project
Ecology – Washington State Department of Ecology
ESA – Endangered Species Act
FS – feasibility study
IAs – Interim Actions
IAWP – Interim Action Work Plan
INNOVEX – INNOVEX Environmental Management
Interstate 5 – I-5
ISCO – in-situ chemical oxidation
ISS – in-situ soil solidification
Kd – partitioning coefficient
l/kg – liters per kilogram
LG – Licensed Geologist
LHg – Licensed Hydrogeologist
LPSB – low permeability soil barrier
mg/kg – milligrams per kilogram
mg/l – milligrams per liter
MNA – monitored natural attenuation
MTCA – Model Toxics Control Act
MW – monitoring well
NPDES – National Pollutant Discharge Elimination System
P429 Plus – P429 and the adjacent proposed future right-of-way (ROW) between P429 and Highway 99
Project – SR 167/I-5 to SR 509 – New Expressway Stage 1b project
PLP – potentially liable person



PRD – parcel restriction documents

RCW – Revised Code of Washington

RFP – request for proposal

RI – remedial investigation

ROW – Right of Way

Site – USG Highway 99 site

SM – silty sand

SR – State Route

USC – U.S. Code

USG – USG Interiors Inc.

WAC – Washington Administrative Code

WSDOT – Washington State Department of Transportation

XRF – Xray Fluorescence



APPENDIX B
SITE LOCATION MAP

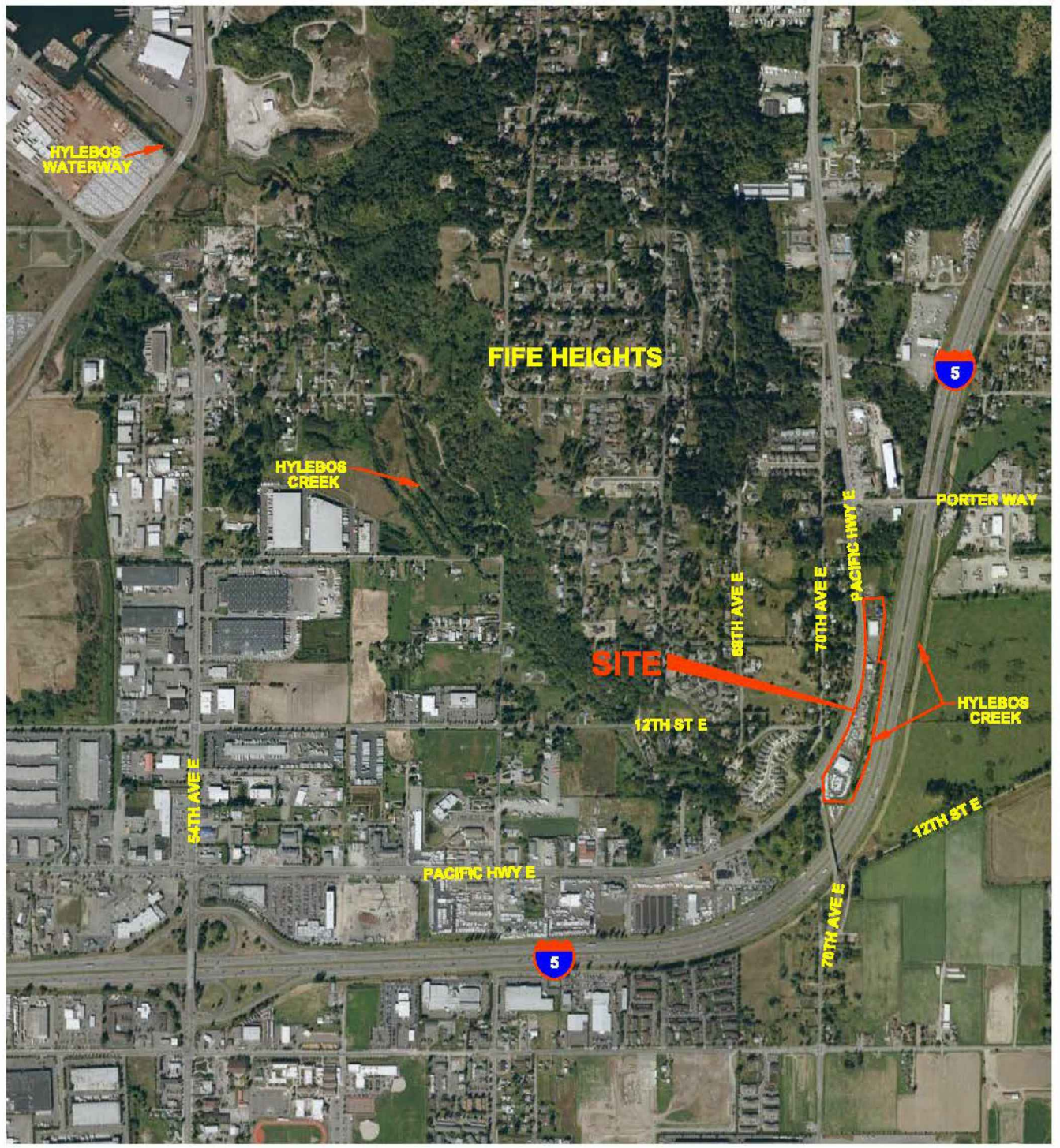

Source: Remedial Investigation Report, USG Interiors Highway 99 Site, Milton, Washington, dated June 23, 2016.

DESIGNED BY Innovex Environmental Anna Jordan	 16310 NE 80th St., Suite 300 Redmond, WA 98052 (800) 988-7880	APPENDIX B Site Location Map 167/I-5 to SR 509 – New Expressway USG Highway 99 Site, Hylebos Creek Contaminated Sediment Removal Interim Action Work Plan
DRAWN BY ICD June 17, 2021		
 SCALE IN FEET		LATITUDE 47D 14M 35S NORTH LONGITUDE 122D 22M 4S WEST REFERENCE: GOOGLE EARTH PRO, 2009



APPENDIX C
SITE FEATURES MAP

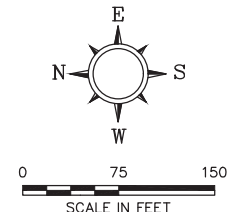
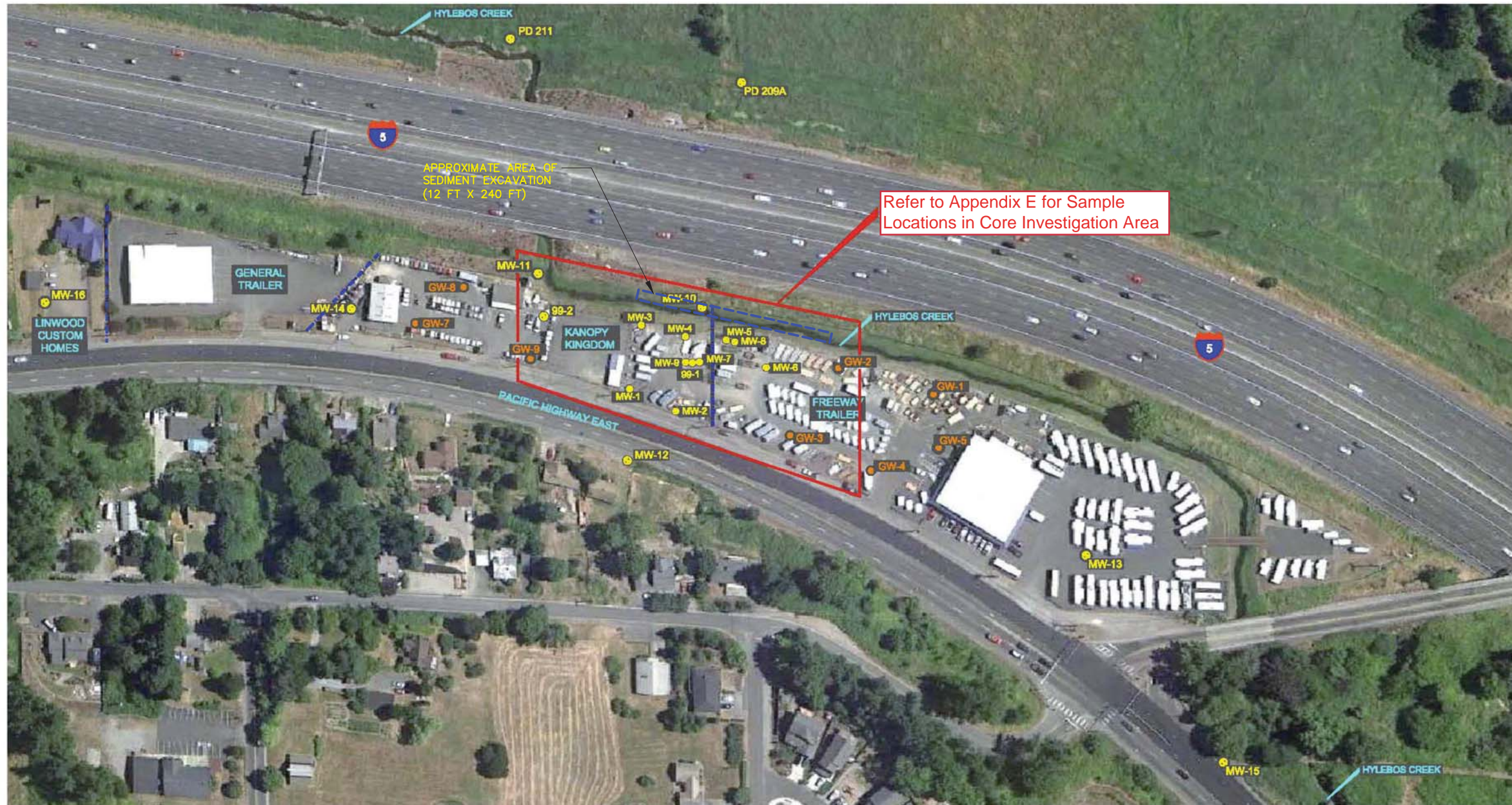

LEGEND

- MW-12 MONITORING WELL
- GW-3 PHASE 2 DPT BORING
- PROPERTY LINE

NOTE:
 MONITORING WELL MW-14 WAS
 DRILLED AT THE LOCATION OF GW-6

DESIGNED BY

Innovex Environmental
 Anna Jordan

DRAWN BY

ICD
 June 17, 2021

**APPENDIX C
 Site Features Map**

**167/I-5 to SR 509 – New
 Expressway | USG Highway 99
 Site, Hylebos Creek
 Contaminated Sediment
 Removal | Interim Action Work
 Plan**



16310 NE 80th St., Suite 300
 Redmond, WA 98052
 (800) 988-7880

Source: Remedial Investigation Report, USG Interiors Highway 99 Site, Milton, Washington, dated June 23, 2016.

REFERENCE: GOOGLE EARTH PRO, 2012, IMAGE DATE AUGUST, 20, 2011



APPENDIX D

GROUNDWATER ELEVATION CONTOUR MAP

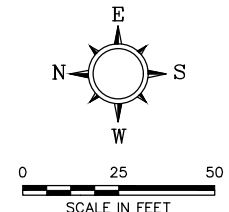

LEGEND

- MW-7 MONITORING WELL
- SW 6 SURFACE WATER SAMPLE
- FENCE
- TOPOGRAPHIC ELEVATION CONTOUR LINE
- GROUNDWATER ELEVATION CONTOUR LINE

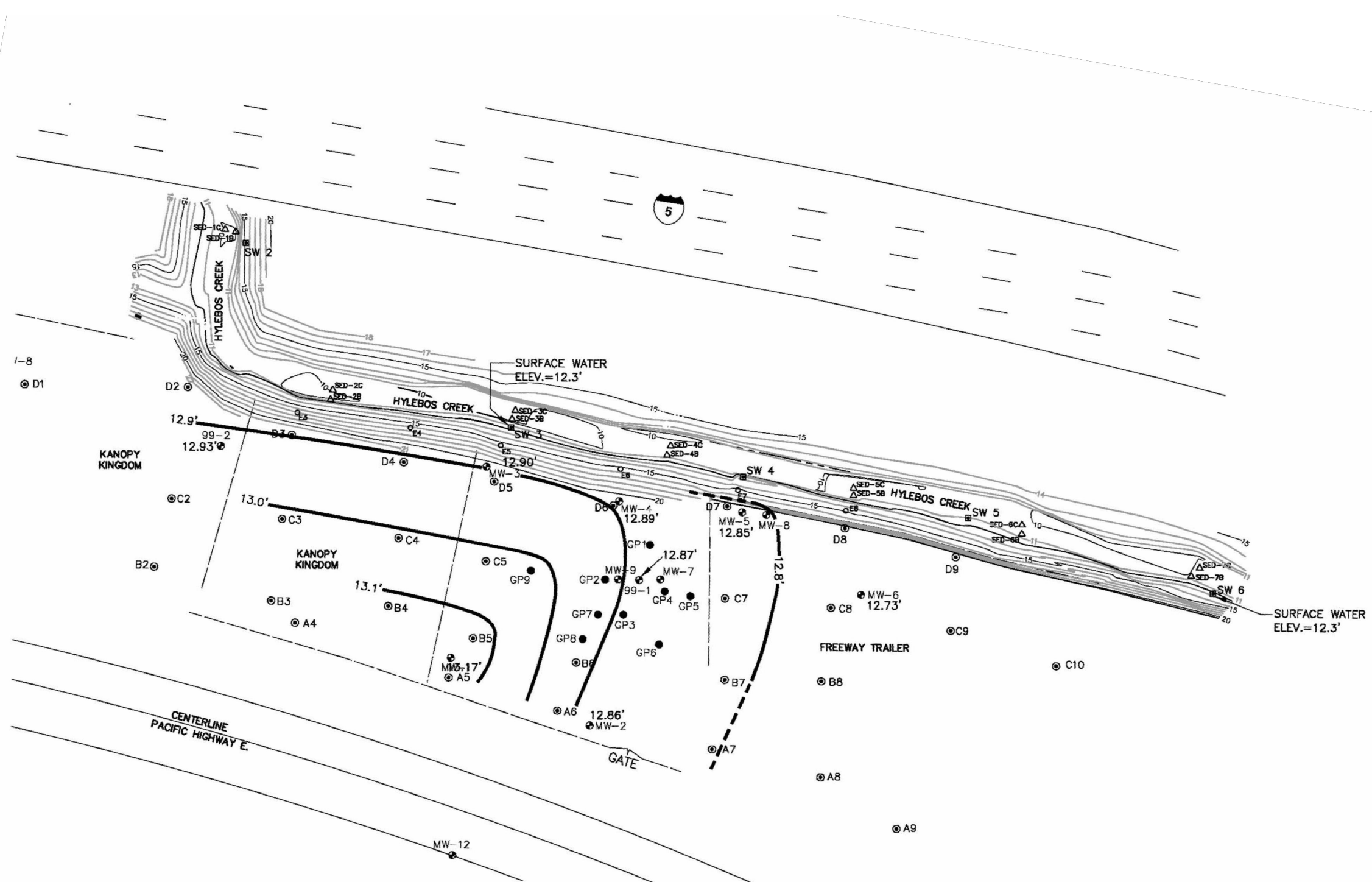

DESIGNED BY

Innovex Environmental
Anna Jordan

DRAWN BY

ICD
June 17, 2021

APPENDIX D
Groundwater Elevation Contour Map
167/I-5 to SR 509 – New Expressway | USG Highway 99 Site, Hylebos Creek Contaminated Sediment Removal | Interim Action Work Plan



16310 NE 80th St., Suite 300
Redmond, WA 98052
(800) 988-7880

Source: Remedial Investigation Report, USG Interiors Highway 99 Site, Milton, Washington, dated June 23, 2016.



APPENDIX E

MAP OF ARSENIC CONTAMINATION IN SOIL

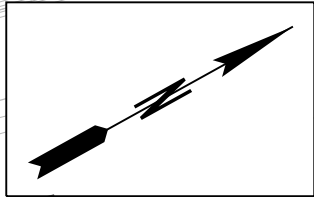

-  >20mg/kg Arsenic in soil
-  >90mg/kg Arsenic in soil
-  >500mg/kg Arsenic in soil
-  Riparian Restoration Plan Area

(Leapfrog model shapes provided by USG Interiors, Inc.)

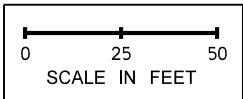

USG Site Arsenic Concentration in Soil

PLOTTED BY: bartlet
DATE: 9/2/2021 TIME: 1:22:12 PM

c:\users\bartlet\pw_wsdot\40375442\XL5466 Relocated\Hy\labos15.dgn



APPENDIX F

MAP OF ARSENIC CONTAMINATION IN GROUNDWATER

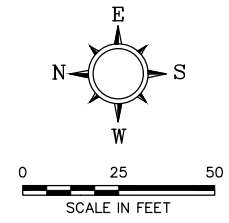
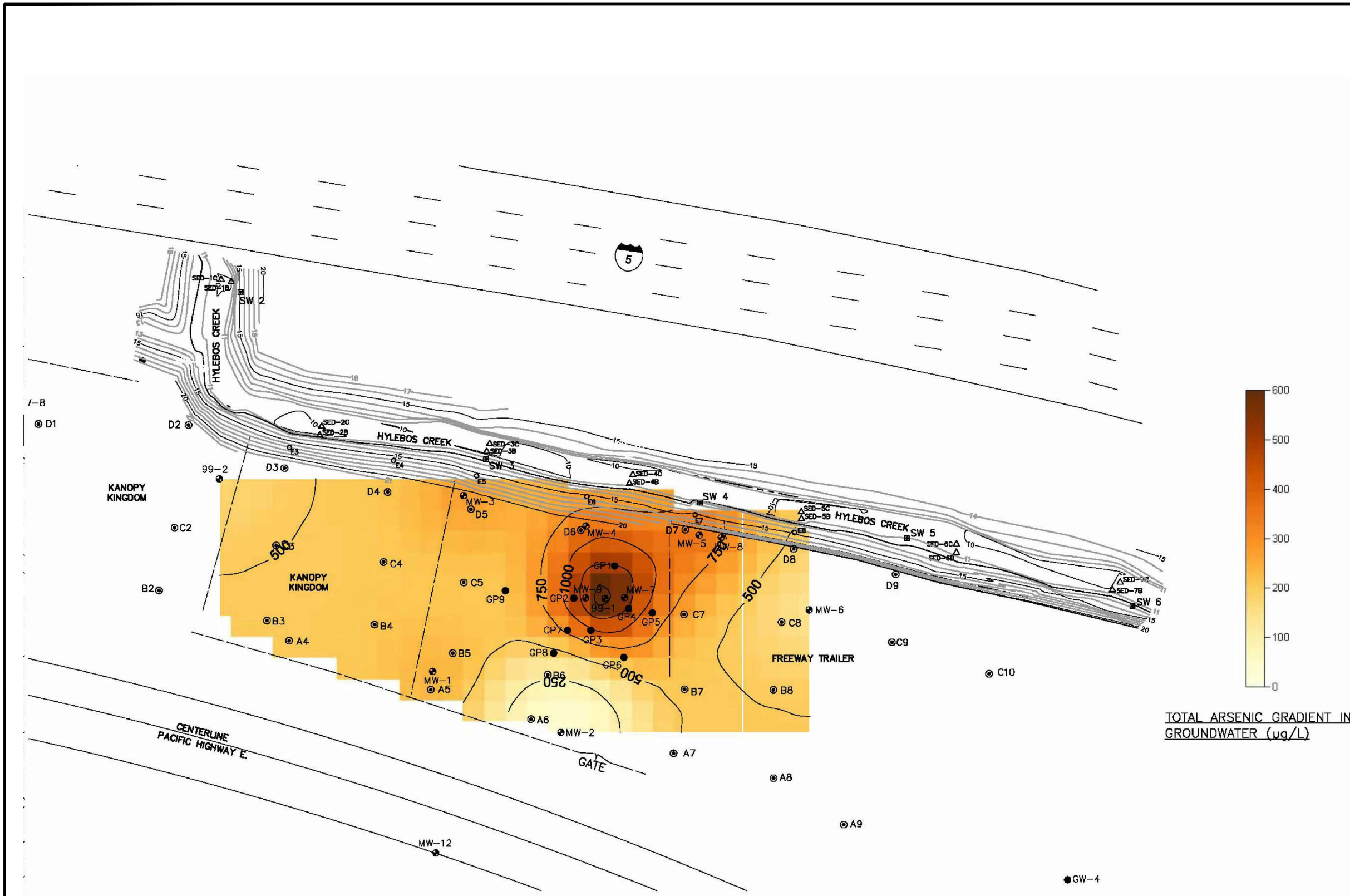

LEGEND

- MW-7 ● MONITORING WELL LOCATION
- A9 ● SOIL BORING LOCATION
- GP6 ● PHASE 1 DPT BORING JUNE 2006
- SED-6C ▲ SEDIMENT SAMPLE LOCATION
- SW 6 □ SURFACE WATER SAMPLE
- ○ SURFACE SOIL SAMPLE LOCATION PHASE 2 DPT BORING APRIL 2011
- FENCE
- TOPOGRAPHIC ELEVATION CONTOUR LINE

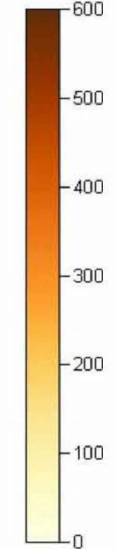

TOTAL ARSENIC GRADIENT IN GROUNDWATER (µg/L)

DESIGNED BY
Innovex Environmental Anna Jordan
DRAWN BY
ICD June 17, 2021
APPENDIX F
Map of Arsenic Contamination in Groundwater
167/I-5 to SR 509 – New Expressway USG Highway 99 Site, Hylebos Creek Contaminated Sediment Removal Interim Action Work Plan



16310 NE 80th St., Suite 300
Redmond, WA 98052
(800) 988-7880

Source: Remedial Investigation Report Addendum USG Interiors Highway 99 Site, Milton, Washington, dated June 23, 2016.



APPENDIX G

CONCEPTUAL SITE PLAN OF INTERIM ACTION

Approximate arsenic in soil > 20 mg/kg per USG Hwy 99 RI

Soil > 20mg/kg Excavated, dlsposed, and restored (See cross section A-A')

ARSENIC IN GROUNDWATER 750 ug/L per USG HWY 99 RI

SURFACE AREAS OF PROPOSED ISS REMEDIATION EXTENTS PER USG HWY 99 CONCEPTUAL DESIGN

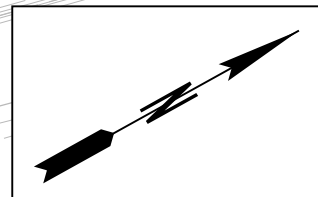

500mg/kg extent per Leapfrog model
90mg/kg extent per Leapfrog model
20mg/kg extent per Leapfrog model

PROPOSED FUTURE ROW

CURRENT STATE ROW

P429

P430

P431

P432

99-1

MW6

MW5

MW8

EASEMENT

ARSENIC IN SOIL > 500 mg/kg per USG HWY 99 Conceptual Design

SEDIMENT REMOVAL AREA per USG HWY 99 DCAP (See cross section B-B')

Potentially contaminated soil to be excavated to construct low permeability soil barrier

c:\users\bartlet\pwws\dot\0375442\XL5466 Relocated\Hy\labos15.dgn

A

B'

C'

C

B

OHW

OHW

OHW

FILL

FILL

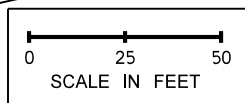

20 Arsenic in soil contour with concentration in mg/kg

Potentially contaminated soil likely to be excavated

Arsenic in soil > 20mg/kg

Contaminated Sediment Removal Area

20mg/kg = MTCA Method A arsenic soil cleanup level

(Leapfrog model shapes and arsenic contours provided by USG Interiors, Inc.)



APPENDIX H

REPRESENTATIVE CROSS SECTIONS

c:\users\bartlet\p_wsd\dot\0375442\XL5466_Relocated\Hylebos15.dgn

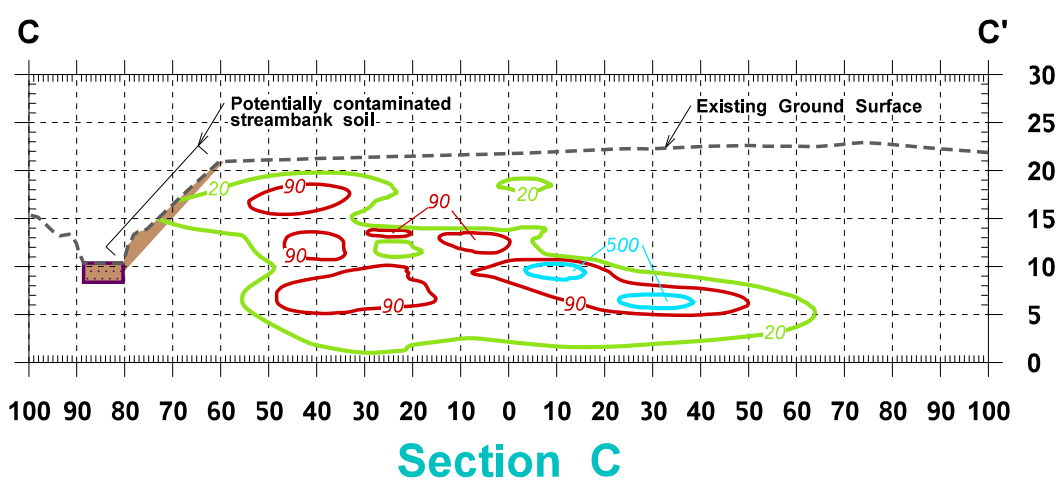
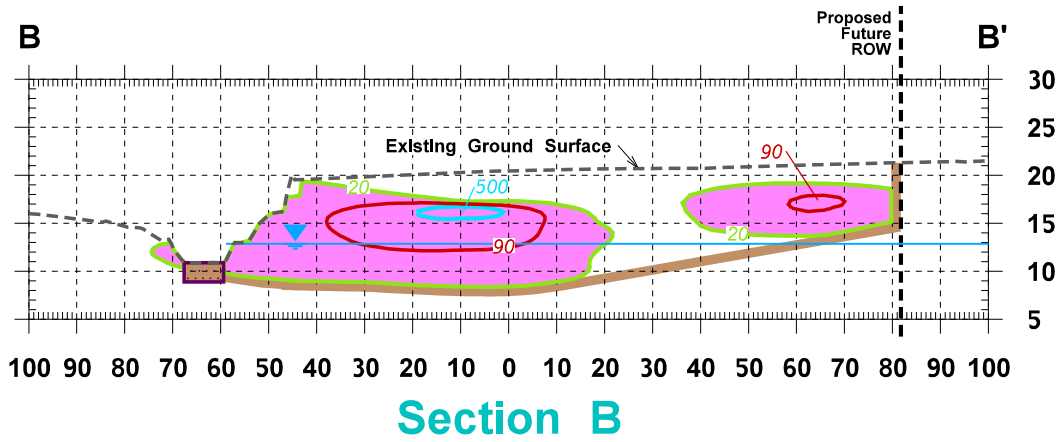
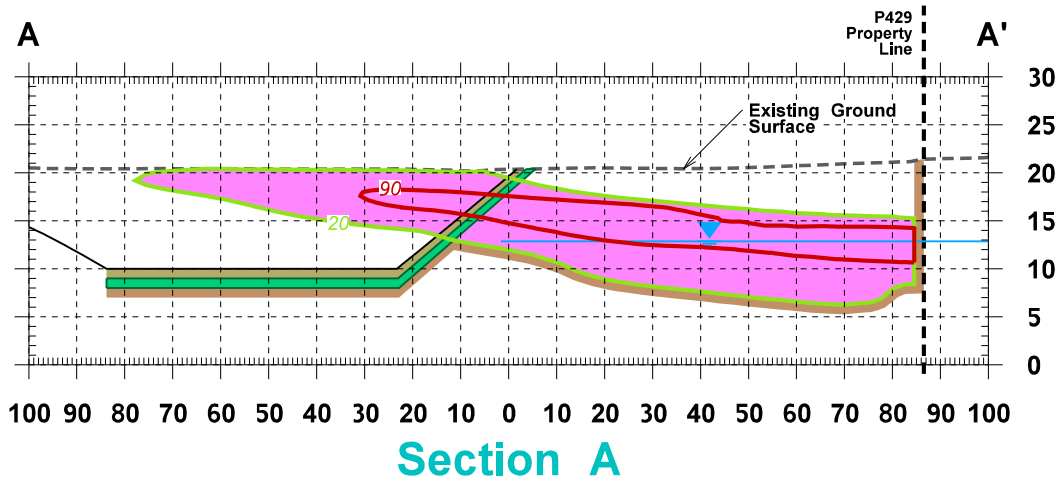

-  12" Streambed Sediment
-  12" Erosion Control Riprap
-  12" Low Permeability Soil Barrier (except in Sediment Removal Area which is 24")
-  Potentially contaminated soil
-  Contaminated Sediment Removal
-  Water Table July 2015
-  20 Arsenic in soil contour with concentration in mg/kg (Arsenic contours from Leapfrog model provided by USG)

Representative Cross Sections

Cross Section A-A' is Proposed Hylebos Creek and Arsenic Contamination from USG Site
 Cross Section B-B' is Existing Hylebos Creek and Arsenic Contamination from USG Site

PLOTTED BY: bartlet
 DATE: 9/2/2021 TIME: 1:15:18 PM



APPENDIX I
WELLS TO BE DECOMMISSIONED

Table 1
Well Construction Details
Highway 99 Site
 USG Interiors
 Milton, Washington

Well I.D.	Northing ^a	Easting ^a	TOC Elevation (ft AMSL) ^b	Boring Total Depth (ft)	Screen Depth Interval (ft)	Casing Diameter (in)	Slot Size (in)	Screen Type	Drilled Date
MW-1	703059.65	1184681.28	23.02	19.0	13-18	2	0.01	PVC	05/05/10
MW-2	702999.60	1184652.77	22.37	19.0	12-19	2	0.01	PVC	05/04/10
MW-3	703045.13	1184763.71	20.22	21.0	14.7-19.7	2	0.01	PVC	05/07/10
MW-4	702987.85	1184749.40	20.40	20.0	14-19	2	0.01	PVC	05/05/10
MW-5	702934.84	1184745.18	19.07	20.0	14.5-19.5	2	0.01	PVC	05/06/10
MW-6	702883.36	1184710.13	19.89	20.0	14.1-19.1	2	0.01	PVC	05/06/10
MW-7	702969.79	1184715.93	21.06	39.0	25-30	2	0.01	PVC	05/05/10
MW-8	702924.45	1184744.14	19.12	40.0	34.9-40.1	2	0.01	PVC	05/06/10
MW-9	702988.01	1184715.80	20.87	59.0	43-48	2	0.01	PVC	05/04/10
MW-10	702958.17	1184783.51	14.15	12.6	10.4-11.5	3/4	0.01	Stainless Steel	10/14/11
MW-11	703185.90	1184844.31	15.41	10.5	9.3-10.5	3/4	0.01	Stainless Steel	10/14/11
MW-12	703065.01	1184585.80	21.54	20.0	14-19	1	0.01	Pre-pack PVC	05/11/12
MW-13	702495.10	1184478.55	22.16	16.0	10-15	1	0.01	Pre-pack PVC	05/11/12
MW-14	703437.40	1184781.81	30.30	20.0	13-18	1	0.01	Pre-pack PVC	05/11/12
99-1	702978.95	1184715.54	21.34	28.0	15-25	4	0.01	PVC	05/1985
99-2	703159.55	1184771.51	22.64	25.5	15-25	4	0.01	PVC	05/1985

Notes:

- a) Washington State Plane North American Datum of 1983 (NAD 83), Zone 12, feet.
 - b) ft AMSL - feet above mean sea level. Elevations based on North American Vertical Datum of 1988 (NAVD 88).
- TOC - top of casing.
 PVC - Polyvinylchloride



LOG OF BORING WITH WELL 19921-65021-APR 26-28 2010.GPJ CDM_BLLV.GDT 5/24/10 REV.

Recovery/ Sample Length (in)	Sample No.	Moisture Content (%)	Dry Density (pcf)	OVA (ppm)	Penetration Resistance (blows / 6 in.)	Depth (feet)	Sample	USCS	Symbol	DESCRIPTION	Elev. (feet)	Well or Piezometer Completion
12"/18"					3 5 7			GP		GRAVEL (GP), light gray, coarse, angular, loose, dry (Fill).		
								SM		Silty SAND (SM), gray-brown, fine to medium sand, subangular, trace gravel, loose, wet (Fill).		
18"/18"					2 2 5			ML		SILT (ML), brown, firm, moist, low plasticity, some orange-brown oxidation, trace concrete fragments.		
								ML		SILT (ML), gray-brown, trace sand, soft, moist, low plasticity, trace organics, some subhorizontal laminations (Alluvium).		
14"/14"					1 1 2			ML				
								SP		SAND (SP), dark gray, poorly graded, fine to medium grained, mostly fine, subrounded grains, red, black and white colored grains, loose, wet, trace wood fragments.		
16"/18"					3 3 5			SP				
										Boring terminated at 20 ft bgs. Monitoring well installed in borehole.		
						25						

Location: _____ Drill Rig: Hollow Stem Auber (Mobile B61)
 Surface Elevation: _____ Equipment/Hammer: SPT - Autohammer/
 Logged By: HY Date Completed: 5-6-10

	USG Corporation Hwy 99 Tacoma, Washington
	<div> <p>Boring Log MW5 Project No: 19921.65021</p> </div> <div> <p>Figure: 38 1 of 1</p> </div>

LOG OF BORING WITH WELL - 19921-65021-APR 26-28 2010.GPJ CDM_BLLV.GDT 5/24/10 REV.

Recovery/ Sample Length (in)	Sample No.	Moisture Content (%)	Dry Density (pcf)	OVA (ppm)	Penetration Resistance (blows / 6 in.)	Depth (feet)	Sample	USCS	Symbol	DESCRIPTION	Elev. (feet)	Well or Piezometer Completion
12"/18"					4			GP		GRAVELLY (GP), light gray, coarse grained, angular, loose, dry (Fill).		
					3			ML		Sandy SILT (ML), dark brown, trace gravel, medium stiff, moist, low plasticity.		
2"/18"					3			SP		SAND (SP), gray, poorly graded, medium grained sand, subangular to subrounded, trace fine gravel, loose, dry, trace wood debris (Fill).		
					8			ML		Sandy SILT (ML), dark brown, trace gravel, very stiff, moist, low plasticity (Fill).		
18"/18"					8			ML				
					9			SM		Silty SAND (SM), gray-brown, fine grained sand, some gray silt interbeds, medium dense, wet (Alluvium).		
0"/18"					10			SM				
					10			SP		SAND (SP), dark gray, poorly graded, fine to medium subrounded grains, medium dense, wet, heaving at 20 ft bgs (description based on auger cuttings).		
					7			SP				
					10			SP				
					12			SP				
						20				Boring terminated at 20 ft bgs. Monitoring well installed in borehole.		
						25						

Location: _____ Drill Rig: Hollow Stem Auber (Mobile B61)
 Surface Elevation: _____ Equipment/Hammer: SPT - Autohammer/
 Logged By: HY Date Completed: 5-6-10

	USG Corporation Hwy 99 Tacoma, Washington
	Boring Log MW6 Project No: 19921.65021

Figure: 39
1 of 1

LOG OF BORING WITH WELL 19921-65021-APR 26-28 2010.GPJ CDM_BLLV.GDT 5/24/10 REV.

Recovery/ Sample Length (in)	Sample No.	Moisture Content (%)	Dry Density (pcf)	OVA (ppm)	Penetration Resistance (blows / 6 in.)	Depth (feet)	Sample	USCS	Symbol	DESCRIPTION	Elev. (feet)	Well or Piezometer Completion
12"/18"					1 1 1	1		GP		GRAVEL (GP), light gray, coarse, angular, loose, dry, some concrete debris.		
								SM		Silty SAND (SM), fine to medium sand, some fine gravel, very loose, moist.		
18"/18"					2 2 1	5		ML		Sandy SILT (ML), brown, fine to medium sand, soft, moist, low plasticity (Fill).		
								ML		SILT (ML), light gray-brown, interlayered with gray, fine silty sand at 7.5 to 8.5 ft bgs, soft, moist, low plasticity, subhorizontal laminations.		
14"/18"					3 3 4	15		SP		SAND (SP), dark gray, poorly graded, fine to medium grained sand, subrounded grains, trace brown organics, red, black, and white grains, loose, wet.		
								ML		SILT (ML), light gray-brown, very stiff, moist, low plasticity, subhorizontal laminations of gray fine sand.		
18"/18"					2 10 12	20		SP		SAND (SP), dark gray, poorly graded, fine to medium sand, subrounded grains, loose, wet, trace wood fragments.		
								ML		SILT (ML), gray, medium stiff, moist, low plasticity, some subhorizontal laminations and interbeds of fine SAND (SP).		

Location: _____ Drill Rig: Hollow Stem Auber (Mobile B61)
 Surface Elevation: _____ Equipment/Hammer: SPT - Autohammer/
 Logged By: HY Date Completed: 5-6-10

	USG Corporation Hwy 99 Tacoma, Washington
	Boring Log MW8 Project No: 19921.65021

Figure: 41
1 of 2

LOG OF BORING WITH WELL 19921-65021-APR 26-28 2010.GPJ CDM_BLLV.GDT 5/24/10 REV.

Recovery/ Sample Length (in)	Sample No.	Moisture Content (%)	Dry Density (pcf)	OVA (ppm)	Penetration Resistance (blows / 6 in.)	Depth (feet)	Sample	USCS	Symbol	DESCRIPTION	Elev. (feet)	Well or Piezometer Completion
18"/18"					5 7 7	27-30	ML SP	ML SP		SAND (SP), dark gray, poorly graded, fine grained, subrounded grains, red, black and white grains, medium dense, wet, some silt.		
18"/18"					2 3 7	30-37	SP-SM	SP-SM		SAND with SILT (SP-SM), dark gray, fine grained, subrounded grains, black, white and red grains, some silt, medium dense, wet.		
12"/18"					2 9 11	37-40	SP	SP		SAND (SP), dark gray, poorly graded, fine to medium grained, subrounded grains, trace silt, red, black and whit grains, medium dense, wet. At 39 ft bgs, some fine GRAVEL (GP), subrounded grains. At 40 ft bgs, the sand is heaving. Boring terminated at 40 ft bgs. Monitoring well installed in borehole.		

Location: _____	Drill Rig: Hollow Stem Auber (Mobile B61)
Surface Elevation: _____	Equipment/Hammer: SPT - Autohammer/
Logged By: HY	Date Completed: 5-6-10

	USG Corporation Hwy 99 Tacoma, Washington
	<div> Boring Log MW8 Project No: 19921.65021 </div> <div style="text-align: right;"> Figure: 41 2 of 2 </div>

Appendix B

Remedial Alternative Cost Estimates

USG ISS Cost Estimates

USG Hwy 99

Quantities and Cost Basis:

Pre-site activities

Finish CAP
Design and Planning
Bid Solicitation, Review, and award
Agency meetings/approval
Contractor Work Plans

Site Activities

Mobilization/staging
Permit equivalents
ISS Subcontractor move/setup/demobe
ISS Subcontractor stabilization
Asphalt demolition/disposal
Clean Soil excavation and on-site stockpile
Grading for work platforms
Erosion control (TESC)
Temporary fencing
Structural road fill and asphalt paving
Post-remediation grading
Site Restoration

Site data

Total assessed area, parcel 0420057007	0.29 acres
Total assessed area, parcel 0420057008	0.28 acres
Estimated site perimeter	720 linear feet
Estimated paved area, 90/210/120/240 ft	23600 sf
Estimated pavement thickness	4 in
Estimated pavement volume	7867 cf
	291 cy
Estimated pavement mass at 2 tons/cy	583 tons
Estimated volume of soil above 500 ppm As	4369 cy
Estimated volume of soil above 250 ppm As	5083 cy
Estimated volume of soil above 88 ppm As	7437 cy
Estimated volume of soil above 20 ppm As	23486 cy

USG ISS Cost Estimates

USG Hwy 99

Quantities and Cost Basis:

Estimated area of soil requiring treatment

500 ppm	10672 sf
250 ppm	13010 sf
88/90 ppm	17420 sf
20 ppm	23429 sf

Estimated volume of clean overburden

500 ppm	1976 cy
250 ppm	2409 cy
88/90 ppm	3226 cy
20 ppm	0 cy

excess soil due to volume expansion

500 ppm	874 cy
250 ppm	1017 cy
88/90 ppm	1487 cy
20 ppm	4697 cy

depth of excess soil if spread out over 0.5 acres

500 ppm	1.1 ft
250 ppm	1.3 ft
88/90 ppm	1.8 ft
20 ppm	5.8 ft

Amount of soil that can be spread over 0.5 acres to 1 ft	807 cy
--	--------

excess volume above 1 ft

500 ppm	67 cy
250 ppm	210 cy
88/90 ppm	681 cy
20 ppm	3891 cy

USG ISS Cost Estimates

USG Hwy 99

COST ESTIMATE**20 ppm Arsenic Scenario**

Estimated duration = 22 weeks

Description	Cost budget	
<u>Studies</u>		
Discussions/Engineering Design Report with Ecology and USG	\$	50,000
Internal plans, meetings, contractor procurement	\$	30,000
Final reports	\$	35,000
Project management	\$	40,000
Permitting	\$	6,000
<u>Studies Subtotal</u>	\$	161,000
<u>Construction</u>		
Engineering Support during construction	\$	22,000
Field support (field tech or engineer)	\$	151,250
Superintendent	\$	145,200
Travel/living	\$	50,600
Travel, for field tech	\$	4,840
Lab Services during construction	\$	25,300
Monitoring well abandonment	\$	9,488
ISS Subcontractor mobe/setup/demobe	\$	215,625
ISS Subcontractor stabilization	\$	4,528,125
Asphalt demolition/disposal	\$	51,600
Clean Soil excavation and on-site stockpile	\$	-
Regrading and compaction after stabilization	\$	-
Transport/Disposal of excess soil	\$	419,448
Erosion control (TESC)	\$	18,975
Structural road fill and asphalt paving	\$	150,778
Monitoring well installation	\$	25,300
Site Restoration	\$	21,563
	\$	-
Portable Restroom	\$	3,795
Survey	\$	5,500
Small Tools	\$	3,795
Safety equipment	\$	3,795
Contingency	\$	973,639
Bond & Insurance	\$	59,155
Construction Subtotal, excluding tax	\$	5,915,507
Construction Subtotal, with tax	\$	6,507,058
Studies Subtotal	\$	161,000
Grand Total	\$	<u>6,668,058</u>

USG ISS Cost Estimates**USG Hwy 99****COST ESTIMATE****90 ppm Arsenic Scenario**

Estimated duration = 12 weeks

Description	Cost budget
<u>Studies</u>	
Discussions/Engineering Design Report with Ecology and USG	\$ 50,000
Internal plans, meetings, contractor procurement	\$ 30,000
Final reports	\$ 35,000
Project management	\$ 40,000
Permitting	\$ 6,000
<u>Studies Subtotal</u>	\$ 161,000
<u>Construction</u>	
Engineering Support during construction	\$ 19,800
Field support (field tech or engineer)	\$ 82,500
Superintendent	\$ 85,800
Travel/living	\$ 28,600
Travel, for field tech	\$ 2,640
Lab Services during construction	\$ 21,505
Monitoring well abandonment	\$ 9,488
ISS Subcontractor mobe/setup/demobe	\$ 215,625
ISS Subcontractor stabilization	\$ 2,156,250
Asphalt demolition/disposal	\$ 51,600
Clean Soil excavation and on-site stockpile	\$ 115,932
Regrading and compaction after stabilization	\$ 115,932
Transport/Disposal of excess soil	\$ 73,392
Erosion control (TESC)	\$ 18,975
Structural road fill and asphalt paving	\$ 150,778
Monitoring well installation	\$ 25,300
Site Restoration	\$ 21,563
	\$ -
Portable Restroom	\$ 1,898
Survey	\$ 5,500
Small Tools	\$ 2,530
Safety equipment	\$ 2,530
Contingency	\$ 526,579
Bond & Insurance	\$ 32,402
Construction Subtotal, excluding tax	\$ 3,240,191
Construction Subtotal, with tax	\$ 3,564,210
Studies Subtotal	\$ 161,000
Grand Total	\$ <u>3,725,210</u>

USG ISS Cost Estimates**USG Hwy 99****COST ESTIMATE****250 ppm Arsenic Scenario**

Estimated duration = 10 weeks

Description	Cost budget	
Studies		
Discussions/Engineering Design Report with Ecology and USG	\$	50,000
Internal plans, meetings, contractor procurement	\$	30,000
Final reports	\$	35,000
Project management	\$	40,000
Permitting	\$	6,000
Studies Subtotal	\$	161,000
Construction		
Engineering Support during construction	\$	17,600
Field support (field tech or engineer)	\$	68,750
Superintendent	\$	72,600
Travel/living	\$	24,200
Travel, for field tech	\$	2,200
Lab Services during construction	\$	18,975
Monitoring well abandonment	\$	9,488
ISS Subcontractor mobe/setup/demobe	\$	215,625
ISS Subcontractor stabilization	\$	1,653,125
Asphalt demolition/disposal	\$	51,600
Clean Soil excavation and on-site stockpile	\$	86,583
Regrading and compaction after stabilization	\$	86,583
Transport/Disposal of excess soil	\$	22,633
Erosion control (TESC)	\$	18,975
Structural road fill and asphalt paving	\$	150,778
Monitoring well installation	\$	25,300
Site Restoration	\$	21,563
	\$	-
Portable Restroom	\$	1,898
Survey	\$	5,500
Small Tools	\$	2,530
Safety equipment	\$	2,530
Contingency	\$	416,753
Bond & Insurance	\$	25,846
Construction Subtotal, excluding tax	\$	2,584,599
Construction Subtotal, with tax	\$	2,843,059
Studies Subtotal	\$	161,000
Grand Total	\$	<u>3,004,059</u>

USG ISS Cost Estimates**USG Hwy 99****COST ESTIMATE****500 ppm Arsenic Scenario**

Estimated duration = 8 weeks

Description	Cost budget	
Studies		
Discussions/Engineering Design Report with Ecology and USG	\$	50,000
Internal plans, meetings, contractor procurement	\$	30,000
Final reports	\$	35,000
Project management	\$	40,000
Permitting	\$	6,000
Studies Subtotal	\$	161,000
Construction		
Engineering Support during construction	\$	13,200
Field support (field tech or engineer)	\$	55,000
Superintendent	\$	59,400
Travel/living	\$	19,800
Travel, for field tech	\$	1,760
Lab Services during construction	\$	15,180
Monitoring well abandonment	\$	9,488
ISS Subcontractor mobe/setup/demobe	\$	215,625
ISS Subcontractor stabilization	\$	1,365,625
Asphalt demolition/disposal	\$	51,600
Clean Soil excavation and on-site stockpile	\$	71,023
Regrading and compaction after stabilization	\$	71,023
Transport/Disposal of excess soil	\$	7,238
Erosion control (TESC)	\$	18,975
Structural road fill and asphalt paving	\$	150,778
Monitoring well installation	\$	25,300
Site Restoration	\$	21,563
	\$	-
Portable Restroom	\$	1,265
Survey	\$	5,500
Small Tools	\$	2,530
Safety equipment	\$	2,530
Contingency	\$	355,024
Bond & Insurance	\$	22,062
Construction Subtotal, excluding tax	\$	2,206,220
Construction Subtotal, with tax	\$	2,426,842
Studies Subtotal	\$	161,000
Grand Total	\$	<u>2,587,842</u>

USG Cost Estimates
 USG Hwy 99
 Long Term Monitoring

Quarterly groundwater monitoring for the first **five** years; every **18 months** thereafter

Description	Cost budget	
Year 1		
Sampling labor, 4x per year	\$	7,200
Lab services, Arsenic	\$	440
Reports	\$	4,000
Project management	\$	4,000
Travel, supplies, safety, small tools	\$	2,200
Environmental Covenant	\$	10,000
<u>Monitoring, Year 1, Total</u>	\$	27,840

Description	Cost budget	
Year 2		
Sampling labor, 4x per year	\$	7,200
Lab services, Arsenic	\$	440
Reports	\$	4,000
Project management	\$	4,000
Travel, supplies, safety, small tools	\$	2,200
<u>Monitoring, Year 2, Total</u>	\$	17,840

Description	Cost budget	
Year 3		
Sampling labor, 4x per year	\$	7,200
Lab services, Arsenic	\$	440
Reports	\$	4,000
Project management	\$	4,000
Travel, supplies, safety, small tools	\$	2,200
<u>Monitoring, Year 3, Total</u>	\$	17,840

Description	Cost budget	
Year 4		
Sampling labor, 4x per year	\$	7,200
Lab services, Arsenic	\$	440
Reports	\$	4,000
Project management	\$	4,000
Travel, supplies, safety, small tools	\$	2,200
<u>Monitoring, Year 4, Total</u>	\$	17,840

Long Term Monitoring

Description	Cost budget	
Year 5		
Sampling labor, 4x per year	\$	7,200
Lab services, Arsenic	\$	440
Reports	\$	4,000
Project management	\$	4,000
Travel, supplies, safety, small tools	\$	2,200
Monitoring, Year 5, Total	\$	17,840

Description	Cost budget	
Year 6 - data evaluation		
Mann-Kendall evaluation and review	\$	15,000
Project management	\$	4,000
Year 6 data evaluation, Total	\$	19,000

Description	Cost budget	
Post remediation monitoring every 18 months		
Sampling labor, 1x per 18 months	\$	1,818
Lab services, Arsenic	\$	110
Reports	\$	4,000
Project management	\$	4,000
Travel, supplies, safety, small tools	\$	550
once per 18-month Monitoring, Total	\$	10,478

Description	Cost budget	
Post ZVI Treatment Quarterly Monitoring, Year 8		
Sampling labor, 4x per year	\$	7,200
Lab services, Arsenic	\$	440
Reports	\$	4,000
Project management	\$	4,000
Travel, supplies, safety, small tools	\$	2,200
Groundwater Monitoring post ZVI , Year 8, Total	\$	17,840

Description	Cost budget	
Post ZVI Treatment Quarterly Monitoring, Year 9		
Sampling labor, 4x per year	\$	7,200
Lab services, Arsenic	\$	440
Reports	\$	4,000
Project management	\$	4,000
Travel, supplies, safety, small tools	\$	2,200
Groundwater Monitoring post ZVI , Year 9, Total	\$	17,840

USG Cost Estimates
USG Hwy 99
ZVI Treatment Cost Estimates

ZVI Treatment - 90 ppm scenario

occurs at year 7
2 weeks in field

Estimated duration

Description	Cost budget	
<u>Studies</u>		
Discussions/Engineering Design Report with Ecology and USG	\$	15,000
Internal plans, meetings, contractor procurement	\$	10,000
Final reports	\$	10,000
Project management	\$	10,000
Permitting	\$	6,000
<u>Studies Subtotal</u>	\$	51,000
<u>Construction - ZVI</u>		
Field support (field tech or engineer)	\$	16,500
Travel, for field tech	\$	440
ZVI injection contractor - injection by push point	\$	379,500
	\$	-
Portable Restroom	\$	633
Small Tools	\$	633
Safety equipment	\$	633
Contingency	\$	31,690
Bond & Insurance	\$	4,023
Construction Subtotal, excluding tax	\$	402,315
Construction Subtotal, with tax	\$	442,546
Studies Subtotal	\$	51,000
Grand Total	\$	<u>493,546</u>

USG Cost Estimates
 USG Hwy 99
 ZVI Treatment Cost Estimates

ZVI Treatment - 250 ppm scenario occurs at year 7
 Estimated duration 12 days in field

Description	Cost budget
<u>Studies</u>	
Discussions/Engineering Design Report with Ecology and USG	\$ 15,000
Internal plans, meetings, contractor procurement	\$ 10,000
Final reports	\$ 10,000
Project management	\$ 10,000
Permitting	\$ 6,000
<u>Studies Subtotal</u>	\$ 51,000
<u>Construction - ZVI</u>	
Field support (field tech or engineer)	\$ 19,800
Travel, for field tech	\$ 528
ZVI injection contractor - injection by push point	\$ 400,000
	\$ -
Portable Restroom	\$ 633
Small Tools	\$ 633
Safety equipment	\$ 633
Contingency	\$ 41,998
Bond & Insurance	\$ 5,335
Construction Subtotal, excluding tax	\$ 533,501
Construction Subtotal, with tax	\$ 586,852
Studies Subtotal	\$ 51,000
Grand Total	<u>\$ 637,852</u>

USG Cost Estimates
 USG Hwy 99
 ZVI Treatment Cost Estimates

ZVI Treatment - 500 ppm scenario occurs at year 7
 Estimated duration 14 days in field

Description	Cost budget
<u>Studies</u>	
Discussions/Engineering Design Report with Ecology and USG	\$ 15,000
Internal plans, meetings, contractor procurement	\$ 10,000
Final reports	\$ 10,000
Project management	\$ 10,000
Permitting	\$ 6,000
<u>Studies Subtotal</u>	\$ 51,000
<u>Construction - ZVI</u>	
Field support (field tech or engineer)	\$ 23,100
Travel, for field tech	\$ 616
ZVI injection contractor - injection by push point	\$ 632,500
	\$ -
Portable Restroom	\$ 633
Small Tools	\$ 633
Safety equipment	\$ 633
Contingency	\$ 52,306
Bond & Insurance	\$ 6,647
Construction Subtotal, excluding tax	\$ 664,688
Construction Subtotal, with tax	\$ 731,157
Studies Subtotal	\$ 51,000
Grand Total	\$ <u>782,157</u>

USG Cost Estimates
 USG Hwy 99
 Net Present Value Calculations for 5 yr + LTM and ZVI

Time value of money 0.07

Long Term Monitoring

	Cost	# of Periods	Costs only in 2023	Present Value in 2022 dollars	Costs in 2023 and 2024	Present Value of quarterly monitoring (2 years) in 2022 dollars	Present values in 2022 dollars ^a
Year 1 (2023)	\$27,912		\$10,000	\$9,346	\$7,434	\$13,441	\$26,085.98
Year 2 (2024)	\$17,840				\$7,434		\$15,582.15
Year 3 (2025)	\$17,840						\$14,562.75
Year 4 (2026)	\$17,840						\$13,610.05
Year 5 (2027)	\$17,840						\$12,719.67
Year 6 evaluation (2028)	\$19,000						\$12,660.50
Year 7 - ZVI injection 500 ppm (2029)	\$782,157						\$487,088.16
Year 7 - ZVI injection 250 ppm (2029)	\$637,852						\$397,221.90
Year 7 - ZVI injection 90 ppm (2029)	\$493,546						\$307,355.65
Year 8 (2030) post ZVI monitoring	\$17,840						\$10,383.04
Year 9 (2031) post ZVI monitoring	\$17,840						\$9,703.78
	Annual Cost						
Years 10 and onward (2025 +)	\$10,478						
Years 1 -10 (20 ppm)	\$10,478	10				\$73,593	
Years 10 -15 (90 ppm)		15				\$27,166	
Year 10	\$10,478						\$5,326.48
Year 11	\$10,478						\$4,978.02
Year 12	\$10,478						\$4,652.36
Year 13	\$10,478						\$4,348.00
Year 14	\$10,478						\$4,063.55
Year 15	\$10,478						\$3,797.71
Years 10 -20 (250 ppm)		20				\$42,737	
Year 16	\$10,478						\$3,549.26
Year 17	\$10,478						\$3,317.07
Year 18	\$10,478						\$3,100.06
Year 19	\$10,478						\$2,897.25
Year 20	\$10,478						\$2,707.71
Years 10 -30 (500 ppm)		30				\$61,755	
Year 21	\$10,478						\$2,530.57
Year 22	\$10,478						\$2,365.02
Year 23	\$10,478						\$2,210.30
Year 24	\$10,478						\$2,065.70
Year 25	\$10,478						\$1,930.56
Year 26	\$10,478						\$1,804.26
Year 27	\$10,478						\$1,686.23
Year 28	\$10,478						\$1,575.91
Year 29	\$10,478						\$1,472.82
Year 30	\$10,478						\$1,376.46

a) PV formula: $PV = FV / (1+r)^t$ where r is the time value of money and t (years later) when payment is received

USG Cost Estimates

USG Hwy 99

Net Present Value Calculations for 5 yr + LTM and ZVI

Alternative	Capital Cost	Present Value of ZVI Treatment	Present Value of LTM	Total Net Present Value
500 ppm	\$ 2,587,842	\$487,088	\$177,063	\$ 3,251,994
250 ppm	\$ 3,004,059	\$397,222	\$158,045	\$ 3,559,326
90 ppm	\$ 3,725,210	\$307,356	\$142,474	\$ 4,175,040
20 ppm	\$ 6,668,058	\$0	\$96,380	\$ 6,764,438

EXHIBIT B

Revised Scope of Work and Schedule

Revised Exhibit B
Scope of Work and Schedule

- A. All work described below is ultimately the responsibility of USG. The Scope of Work is revised as follows:

Phase 1, Core Remediation Area (ISS Treatment)

1. Prepare Engineering Design Report (EDR) for ISS treatment in the Core Remediation Area consistent with the requirements in MTCA WAC 173-340-400 (4)(a)(i) through 173-340-400 (4)(a)(xx).
2. Prepare construction plans and specifications consistent with the approved EDR and consistent with the applicable requirements in MTCA WAC 173-340-400 (b).
3. Implement Phase 1, ISS treatment in the Core Remediation Area.
4. Prepare Construction Completion Report for Phase 1 Core Remediation Area.
5. Prepare an operation maintenance and monitoring plan (OMMP) to monitor groundwater in the ISS treatment of the Core Remediation Area portion of the site consistent with the requirements in WAC 173-340-410.

Phase 2, Excavation of Hylebos Creek Sediment and P429 Plus Property

1. WSDOT's Design Builder to prepare Construction Plans and Specifications for excavation of Hylebos Creek sediments and P429 Plus property consistent with the requirements in MTCA WAC 173-340-400 (4)(a)(i) through 173-340-400 (4)(a)(xx).
2. WSDOT's Design Builder to prepare Compliance Monitoring Plans to monitor the excavation of Hylebos Creek sediments and P429 Plus property consistent with the requirements in WAC 173-340-410.
3. WSDOT's Design Builder to prepare a Disposal and/or Treatment Plan for contaminated dewatering water, soil and sediment.

4. WSDOT to prepare Construction Completion Report for Phase 2 Excavation of Hylebos Creek Sediment and P429 Plus Property.
5. USG to combine Phase 1 and Phase 2 into one Construction Completion Report for site.
6. USG to modify the OMMP to incorporate groundwater monitoring within the P429 Plus Property.

Groundwater Trend Analysis

1. USG to evaluate the effectiveness of the ISS treatment in the Core Remediation Area and excavation of Hylebos Creek Sediment and P429 Plus property after five years of quarterly groundwater monitoring in the Core Remediation Area. Determine if there is a declining trend of contaminant concentrations in groundwater. If there is no declining trend in groundwater concentrations on site, design and implement treatment of the contaminated groundwater in accordance with the Ecology schedule as detailed in the OMMP.

B. Table A: Schedule for Performance and/or deliverables is revised as follows:

Tasks For Phase 1	Schedule to Submit to Ecology
Submit a Draft EDR for the Core Remediation Area.	120 days after agreed order amendment effective date
Submit the final EDR for the Core Remediation Area	30 days after receipt and incorporation of Ecology comments on the draft EDR.
Submit Draft construction plans and specifications for the Core Remediation Area	120 days after submittal of the final EDR for the Core Remediation Area
Submit Final construction plans and specifications for the Core Remediation Area	30 days after receipt and incorporation of Ecology comments on the draft construction plans and specifications
Begin Contractor Procurement for ISS treatment in the Core Remediation Area	45 days after receiving Ecology approval of final construction plans and specifications for the Core Remediation Area
Begin cleanup action in the Core Remediation Area	90 days after procuring contractor
Complete cleanup action in the Core Remediation Area	120 days after starting cleanup action
Submit Construction Completion Report and OMMP for Core Remediation Area	90 days after completion of cleanup action

Tasks Phase 2	
Submit Draft construction plans and specifications for the P429 Plus Area and Hylebos Sediment Excavation Area	270 days after agreed order amendment effective date
Submit Final construction plans and specifications for the P429 Plus Area and Hylebos Sediment Excavation Area	60 days after receipt and incorporation of Ecology comments on the draft construction plans and specifications
Submit Draft Compliance Monitoring Plan	330 days after agreed order amendment effective date
Submit Final Compliance Monitoring Plan	60 days after receipt and incorporation of Ecology comments on the draft Compliance Monitoring Plan
Submit Draft Disposal and/or Treatment Plan	330 days after agreed order amendment effective date
Submit Final Disposal and/or Treatment Plan	60 days after receipt and incorporation of Ecology comments on the draft Disposal and/or Treatment Plan
Begin Cleanup Action for the P429 Plus Area and Hylebos Sediment Excavation Area	Summer 2024 or Summer 2025.
Submit Construction Completion Report for the P429 Plus Area and Hylebos Sediment Excavation Area	120 days following completion of cleanup action
Submit recorded environmental restrictive covenants.	1 year after completion of cleanup actions for Phase 1 and 2
Submit Combined Construction Completion Report for Phase 1 and 2 and revised OMMP	90 days following submittal of Phase 2 Construction Completion Report
Groundwater Trend Analysis Report	5 years after completion of cleanup action for Phase 1