

*2011 Interim Action Work Plan
NuStar Vancouver Facility
Vancouver, Washington*

Prepared for:
NuStar Terminals Services, Inc

March 25, 2011
1126-09



Ash Creek Associates, Inc.
Environmental and Geotechnical Consultants

2011 Interim Action Work Plan NuStar Vancouver Facility Vancouver, Washington

**Prepared for:
NuStar Terminals Services, Inc**

**March 25, 2011
1126-09**

*Michael W. Stevens, P.E.
Associate Engineer, Ash Creek Associates*

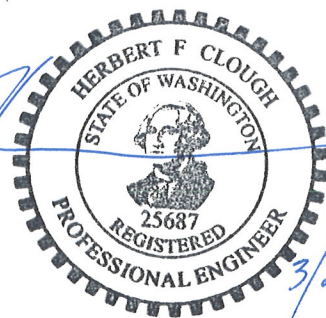

*Herbert F. Clough, P.E.
Principal Engineer, Ash Creek Associates*

Table of Contents

1.0 INTRODUCTION	1
1.1 Definition of Property	1
1.2 Purpose	2
1.3 Work Plan Organization.....	2
2.0 BACKGROUND	2
2.1 Property Location, Description, and History	2
2.2 Property Operations	3
2.3 Geology and Hydrogeology	3
2.4 Remedial Investigation	6
2.5 Risk Assessment	7
2.6 Feasibility Study	8
2.7 Interim Actions.....	9
3.0 EXTENT OF INTERIM ACTION.....	11
3.1 Soil.....	11
3.2 Groundwater.....	11
4.0 DESIGN ANALYSIS – SOIL VAPOR EXTRACTION	12
5.0 DESIGN ANALYSIS – ENHANCED BIOREMEDIATION.....	14
6.0 SCHEDULE	17
7.0 REFERENCES	19

Figures

1	Property and Site Location Map
2	Property Plan
3	Geologic Cross-Section A-A'
4	Extent of Total Molar Chloroethenes in Soil – Vadose Zone
5	Extent of COPCs in Shallow Zone Groundwater
6	Existing Interim Action
7	Soil Interim Action Area
8	Groundwater Interim Action Area
9	Proposed Layout of SVE System
10	Proposed Bioremediation Layout

Appendices

A	Interim Action Performance Evaluation Report
B	Soil Vapor Extraction Design
C	Design Support
D	Bioremediation Design



1.0 Introduction

This work plan presents the design for additional interim action at the NuStar Terminals Services, Inc. (NuStar) bulk storage terminal at the Port of Vancouver Terminal No. 2, located at 2565 NW Harborside Drive in Vancouver, Washington (the Property). A Property location map is provided as Figure 1. The Property is defined as the area within the 2006 NuStar leasehold boundary. Work was performed pursuant to Agreed Order (AO) No. 07-TC-S DE3938 between the Washington State Department of Ecology (Ecology) and NuStar.

A Remedial Investigation (RI) and Feasibility Study (FS) were conducted to collect, develop, and evaluate information sufficient for selecting a cleanup action. The RI report was submitted to Ecology in September 2008. Based on comments received from Ecology in July 2009, a revised RI report was submitted in October 2009 (Ash Creek, 2009a). A Baseline Risk Assessment (RiA) is documented in the *Baseline Risk Assessment Report* submitted to Ecology in September 2008 that provides quantitative potential risk to human health and the environment (Ash Creek, 2008). A draft FS was submitted to Ecology in January 2010 and is currently under review. Ecology has requested additional work prior to approval of the RI/FS.

In 2008, NuStar initiated interim action activities in the primary release area at the Property. The interim action activities included enhanced bioremediation injections and installation and operation of a soil vapor extraction (SVE) system. These activities have successfully reduced the concentrations of chemicals of concern (COC) in the release area and treatment is continuing.

Given that RI/FS work is continuing, the draft FS identified area beyond the current interim action to target for remediation, and interim actions have been successful in the release area, NuStar has elected to complete additional interim action at the Property. The proposed additional interim action includes expansion of the existing SVE system, additional bioremediation injections in the current interim action area, and bioremediation injections in an expanded interim action area.

1.1 Definition of Property

As discussed in the section above, the "Property" refers to the NuStar 2006 leasehold area. Features in this report may be referred to as "off-Property" or "on-Property" when describing physical location relative to the 2006 leasehold boundary. The 2006 leasehold boundary is shown on Figure 2. In 2009, NuStar leased additional property to the north, outside of the 2006 leasehold boundary. The additional property is not located in the area of historical activities relevant to the RI/FS (i.e., solvent handling, etc.), thus is not included in the Property.



1.2 Purpose

The purpose of this interim action work plan is to define the scope and schedule for implementation of interim actions in the target remediation area defined in the draft FS.

1.3 Work Plan Organization

Background information, the RI, RiA, and FS are summarized in Section 2. The locations of the proposed interim actions are discussed in Section 3. The basis for the design of the interim actions is presented in Sections 4 and 5. A project schedule is presented in Section 6. Supporting information, including detailed design drawings for the interim actions, are included in Appendices.

2.0 Background

2.1 Property Location, Description, and History

Location. The Property is located at the Port of Vancouver Terminal No. 2 in Vancouver, Washington (as shown on Figure 1). The Property address is 2565 NW Harborside Drive, Port of Vancouver, Vancouver, Washington 98660 (Latitude: N45° 38.26', Longitude: W122° 42.20'). The Property is owned by the Port of Vancouver (Port) and leased by NuStar.

Physical Features. Figure 2 is a Property Plan. The Property is roughly rectangular with nominal dimensions of 600 by 1,300 feet and a total area of approximately 17 acres. The Property is on the north shore of the Columbia River. Land on the other sides is industrial land also owned by the Port. The Property is located on Clark County Tax Lot (TL) Nos. 151979-000, 502010-002, 502010-000, and a portion of 502020-000, as well as a portion of the Washington Department of Natural Resources tideland area managed by the Port.

The Property includes five buildings (Warehouses 9, 13, 14, 15, and 17), a loading dock, three aboveground storage tank (AST) farms, two tank truck loading/unloading racks, a rail tank car loading/unloading area, marine vessel dock and piping, and an office. The ground surface is nearly flat at an elevation typically between 32 and 34 feet above mean sea level (MSL). The majority of product piping is aboveground.

The Property includes extensive underground utilities. Utilities are within about 10 feet of the ground surface, above the groundwater table.

The Property ground surface coverage consists of the following (with approximate aerial extent):

- Buildings (35 percent);
- Paved areas (45 percent);



-
- Tanks (5 percent); and
 - Gravel/bare ground (15 percent).

Property History. Historical aerial photographs were reviewed to identify the developmental history of the Property and were presented in the RI report (Ash Creek, 2009a). In summary, the Property was undeveloped into the 1940s. Filling occurred throughout the 1940s and 1950s, and development began about 1960 with Warehouse 9 and several ASTs. Expansion of facilities on the Property occurred periodically between the 1960s and 2000.

2.2 Property Operations

In general, the Property was developed to receive, store, and handle bulk fuel and chemicals. Typically, these chemicals were not owned by the terminal operator. Rather, the terminal operator entered into agreements as a wholesale distributor to handle chemicals for owners. The terminal was owned/operated by GATX from the early 1960s through 1998 (GATX has since been acquired by Kinder Morgan). The terminal was acquired in 1998 by ST Services, a subsidiary of Kaneb Pipeline Partners L.P. (Kaneb). Kaneb was acquired in 2005 by Valero L.P. Valero L.P. changed its name to NuStar Energy L.P. in 2007.

Although a variety of products have been handled at the Property over the years, the historical sampling has identified chlorinated solvents as the chemicals of interest. Historical company records suggest that handling of chlorinated solvents may have ended as early as 1990, but the end date is uncertain. Currently, products such as fertilizer, jet fuel, biodiesel, methanol, and wood preservative are received and transported via ship, pipeline, railcar, and trucks at the Property. Products are also blended, packaged, and stored on the Property.

2.3 Geology and Hydrogeology

This section presents the understanding of the geology and hydrogeology as discussed in the RI (Ash Creek, 2009a).

2.3.1 Geology

The vicinity of the Property is dominated by two primary units: unconsolidated alluvial and catastrophic flood deposits and the Troutdale Formation. Information on the regional geology is summarized below based on SECOR (2001) and AMEC (2005). Information on the Property's geology and hydrogeology was obtained during the remedial investigations (Ash Creek, 2009).

The alluvial and flood deposits are the upper unit and comprise the USA hydrogeologic unit. For consistency with previous reports, this unit is referred to as the USA herein. The thickness of the USA varies, observed to range from 125 to 200 feet thick within the areas investigated at and near the Port. The



unit consists of alluvial deposits of the Columbia River and the catastrophic Missoula Floods. The upper portion contains unconsolidated silt and sand. The lower portion generally consists of sand or sand and gravel.

The Troutdale Formation underlies the USA and can be in excess of 1,000 feet thick. The base of the USA is typically identified by the transition to an underlying conglomerate or consolidated/unconsolidated silty, sandy gravel of the Pleistocene Troutdale Formation.

Figure 3 presents a geologic cross-section through the Property. The upper part of the USA that underlies the Property consists of fine to coarse sand with variable layers of silt or silty sand. The upper sandy zone extends from the ground surface to a depth of up to 50 feet beneath the western and central portions of the Property and extending south to the Columbia River. Within the upper USA, a silt layer is present on the north and east parts of the Property. At the northern Property boundary, the silt is encountered at depths as shallow as 9 to 10 feet below the ground surface (bgs) and extends to depths of approximately 40 feet bgs. This layer is continuous along the north and east of the Property, forming a low-permeability ridge at the Property boundary. The upper contact of the silt appears to coincide with the historical riverbank. The sand lying above the silt corresponds to the fill observed being placed in aerial photographs from 1948 through 1961.

A silty gravel layer underlies the sandy/silty layers of the upper USA beneath the Property. The silty gravel grades into the coarse sand and/or gravel of the lower portion of the USA. The depth to the top of the silty gravel varies from 39 (north) to 50 (south) feet bgs beneath the Property. North of the northern Property boundary (i.e., north of the silt ridge), the shallow geology is predominantly silt. The silty gravel is not observed and a sand layer is found between the silt and underlying sand and gravel. The Troutdale Formation underlies the sand and gravel unit; however, borings installed to depths of up to 140 feet bgs at the Property have not encountered the Troutdale Formation.

2.3.2 Hydrogeology

The regional aquifers follow the regional geology discussed above. The alluvial and catastrophic flood deposits comprise the USA. The USA is unconfined and receives recharge directly from the land surface and/or surface water features. Based on numerous studies conducted in the Port area, the following aquifer terminology has been adopted:

- Shallow Zone – The Shallow Zone corresponds to first encountered groundwater, generally the upper 20 to 30 feet of the saturated zone. At the Facility, depth to first encountered groundwater is generally 21 to 33 feet below grade (elevation of 5 to 12 feet). The bottom of the Shallow Zone is about elevation -10 to -20 feet, or a depth of about 40 to 50 feet.
- Intermediate Zone – The Intermediate Zone generally corresponds to the middle of the USA. This zone is most directly influenced by pumping wells in the USA. The Intermediate Zone lies between



approximate elevations -15 and -100 feet. At the Facility, the Intermediate Zone is between the depths of about 55 and 130 feet.

- Deep USA Zone – The Deep Zone includes the lower part of the USA and in some areas, the reworked gravel at the top of the Troutdale Formation.
- TGA – The TGA corresponds to the Troutdale Formation and underlies the USA in the project area. Flow in the TGA is less influenced by regional groundwater pumping and more by regional recharge and discharge influences.

Figure 3 shows an interpretation of the hydrogeologic units at the Property. Beneath most of the Property, the Shallow Zone lies within the sand layer overlying the silty gravel. Along the northern Property boundary and continuing to the north, the Shallow Zone lies entirely within the silt layer. As a result, the silt layer forms a low-permeability zone that greatly impedes hydrogeologic communication between the Shallow and Intermediate Zones on the Property, and effectively isolates the Shallow Zone on-Property from the Shallow Zone off-Property. Off-Property to the north, the sand layer beneath the silt layer is hydrogeologically connected to the underlying sand and gravel, so is therefore effectively part of the Intermediate Zone.

A groundwater divide, approximately parallel to the river bank is present in the central portion of the Property within the Shallow Zone, generally corresponding to the southern edge of the “silt ridge” at the Property. Groundwater south of the groundwater divide is more sensitive to tidal variations. Shallow groundwater to the north of the divide appears to be less tidally influenced and generally flows away from the river. The presence of the silt ridge, coupled with the groundwater divide, effectively isolates the most impacted Shallow Zone groundwater at the Property from the influences of pumping from the Shallow or Intermediate Zones north and east of the Property. Furthermore, given that the geologic source of the silt ridge is the former natural river bank, this feature is believed to be continuous well beyond the Property boundaries to the east and west.

Intermediate Zone groundwater flow is currently being evaluated. Transducers were installed in five site Intermediate Zone wells in December 2010. Water elevation data collected from these transducers will be combined with transducer data from other regional wells screened in the Intermediate Zone to prepare regional groundwater flow maps.

The lower reaches of the Columbia River – where the Property is located – are subject to tidal variations as well as seasonal and stage variations due to precipitation and regulation of river flow by dams.

In 1999, an aquifer test was conducted to evaluate hydraulic properties of the Shallow Zone on the Property (SECOR, 1999a). The analysis of data collected during aquifer pumping in the central area of the Property resulted in an estimated Shallow Zone aquifer transmissivity of 0.82 square feet per minute (ft²/min) to 6.4 ft²/min and an aquifer storativity of 0.002 to 0.005. The transmissivity of the Intermediate Zone has been estimated by others to range from 200 to 1,250 ft²/min (Parametrix, 2008).



Deep groundwater is found in the Troutdale Formation which underlies the catastrophic flood deposits and alluvial deposits that make up the USA in the project area. The depth to the top of the Troutdale Formation varies significantly in the project area, and has been encountered at a depth of 98 feet directly north of the Property but is below a depth of 140 feet beneath the Property. The Troutdale Formation contains more fines than the USA and ranges from consolidated to semi-consolidated due to cementation. The differing lithology of the Troutdale Formation results in a transmissivity of the TGA at least an order of magnitude lower than the USA (Parametrix, 2008).

2.3.3 Surface Water and Surface Water Drainage

The Columbia River bounds the Property to the southwest. The Property is situated on the Columbia River flood plain. As described in Section 2.1, the majority of the Property is covered with an impermeable surface (i.e., buildings, asphalt, concrete). Surface water in the terminal area is directed to a permitted stormwater system that is maintained by the Port.

2.3.4 Aquatic and Terrestrial Habitat

The Columbia River is located along the southwest boundary of the Property. Aquatic organisms including anadromous and resident fish species, some of which are threatened or endangered, use parts of the river during various stages in their life cycles. As discussed in Section 2.1, the Property and surrounding area are covered with impermeable surfaces and provide no terrestrial habitat.

2.4 Remedial Investigation

Since 1980, numerous investigations have been conducted by various parties. These investigations identified the presence of chlorinated solvents and associated breakdown products, primarily tetrachloroethene (PCE), trichloroethene (TCE), and cis-1,2-dichloroethene (DCE) in soil, groundwater, and soil vapor. Most of the planned investigation activities were completed between 1980 and 2009. Together, these activities comprise the RI (Ash Creek, 2009a) findings to date summarized in this section.

Land Use. The RI report presents supporting documentation indicating the site is an industrial property as defined by WAC 173-340-200.

Groundwater Use. Groundwater at the Property is not currently used for any purpose. As discussed in Section 2.3.2, a groundwater divide is present in the Shallow Zone groundwater. Groundwater south of the divide has a southerly gradient on much of the Property, is tidally influenced, and discharges to the Columbia River. Groundwater north of the ridge is less tidally influenced and generally flows away from the river. The Intermediate Zone beneath the Property is a productive aquifer that is used regionally for municipal and industrial water supply.



Surface Water. There are no surface waters on the Property. The Columbia River is located adjacent to the Property, to the south. The Columbia River has a variety of uses including serving as an active channel for large commercial ships. The river is not currently used for drinking water in Vancouver or within several miles of the Property and is not likely to be used for drinking water within the foreseeable future. Anadromous and resident fish species use parts of the river during various stages in their life cycles. A number of local American Indian tribes have fishing rights on the Columbia River. The Columbia River is also used for fishing for sport and consumption and for recreational boating.

Chemicals of Potential Concern. A screening of chemical data identified the chemicals of potential concern (COPCs) in soil and groundwater to be chlorinated solvents and associated degradation products. Three COPCs (PCE, TCE, and vinyl chloride [VC]) account for greater than 99.9 percent of potential human health risk based on comparison to screening levels (Ash Creek, 2008). Cis-1,2-DCE is a breakdown product of PCE and TCE and will break down into VC. These four compounds represent the primary human health COPCs. In addition, PCE, TCE, cis-1,2-DCE, 1,1-dichloroethene, 1,1,1-trichloroethane, and 1,1-dichloroethane were identified as COPCs based on screening levels for aquatic organisms.

Extent of COPCs in Soil. A review of soil analytical data indicate that the relatively highest molar concentrations of COPCs in vadose zone soil (<25 feet bgs) are present near location AGP-22 and locations AGP-28/AGP-29. The COPCs in vadose zone soil are predominantly PCE, with lesser concentrations of TCE and cis-1,2-DCE. The extent of total molar chloroethenes in soil is shown on Figure 4.

Extent of COPCs in Shallow Zone Groundwater. Figure 5 shows the extent of COPCs in Shallow Zone groundwater. Shallow-zone COPCs emanating from source areas within the NuStar facility property are limited to within about 100 feet of the Property boundary to the north and up to 300 feet of the Property to the west and east in the Shallow Zone. The river defines the extent of halogenated volatile organic compounds (HVOCs) to the south. It is anticipated that there will be net discharge from the Shallow Zone groundwater to the river.

2.5 Risk Assessment

A baseline RiA was completed in accordance with the requirements for determining cleanup standards under MTCA (Ash Creek, 2008).

Human Health. The baseline human health risk assessment indicated that the potential hazards associated with non-carcinogens or the estimated excess lifetime cancer risks associated with carcinogens were acceptable with the exception of the vapor intrusion pathway and a hypothetical (future) drinking water pathway.

Ecological. The Property is within an industrial area, is generally covered with buildings and pavement, and has little or no habitat, so terrestrial ecological risk is acceptable. Several COPCs are estimated to potentially exceed conservative effects-based concentrations in surface water or sediment at the groundwater/surface water interface.

2.6 Feasibility Study

Based on the results of the RI and risk assessment, an FS was completed in accordance with MTCA. The draft FS report was submitted to Ecology in January 2010 (Ash Creek, 2010b).

Cleanup standards were developed for soil and groundwater as follows.

- Soil – Cleanup levels for soil were developed in accordance with MTCA Method C. Each applicable pathway was considered and cleanup levels protective of groundwater (as a drinking water source) were the controlling cleanup levels. The standard point of compliance for soil cleanup levels to protect groundwater is throughout the site.
- Groundwater – Cleanup levels for groundwater were developed in accordance with MTCA Method B. Groundwater cleanup levels were established to be protective of groundwater as a drinking water source. Cleanup levels protective of air, sediment, and surface water were also evaluated in the development of the groundwater cleanup standard. Groundwater cleanup levels protective of drinking water are presumed to be adequate to protect the air pathway. Two cleanup levels were developed for each COC based on the point of compliance. The first is a cleanup level protective of the drinking water pathway. The second represents the pathway protective of surface water/sediment for each COC (whichever is the lower value). The standard groundwater point of compliance is the saturated zone throughout the site and corresponds to the drinking water pathway cleanup level. For the surface water/sediment protective groundwater cleanup level, the point of compliance is the point where groundwater enters the surface water.

Cleanup alternatives were developed and evaluated in accordance with MTCA requirements. To select a cleanup action that uses permanent solutions to the maximum extent practicable, the groundwater cleanup action alternatives were subjected to a disproportionate cost analysis. Based on a comparative analysis, the groundwater cleanup action alternatives were ranked from most to least permanent, as follows: enhanced bioremediation, reactive treatment wall/enhanced bioremediation, and groundwater extraction/treatment.

Based on the results of the FS, the recommended cleanup action alternative for the site is SVE combined with enhanced bioremediation and monitored natural attenuation (MNA). The current interim action SVE system would be expanded to address the soil above cleanup levels. Enhanced bioremediation would be used to treat groundwater and saturated soil corresponding to the majority of site risk. MNA would be used to address residual concentrations of COC in peripheral areas of soil and groundwater. Groundwater use



restrictions, as part of a restrictive covenant or equivalent, would be implemented. Monitoring would be used to evaluate the concentrations of COC in soil, groundwater, and/or vapor to evaluate the effectiveness of the cleanup action.

2.7 Interim Actions

The results of the RI indicate that the primary release area is located between Warehouses 13 and 15, beneath the rail siding north of these warehouses, and extending south toward the sea wall. Rail car off-loading historically occurred at the north end of this area. Soil vapor, vadose zone soil, saturated zone soil, and groundwater data support that releases occurred in this area. Two interim actions have been conducted at this release area. A summary of each is provided below.

2.7.1 Interim Action – 2000 through 2005

Pursuant to a 1998 AO between Ecology and Support Terminals Services, Inc. (a.k.a. ST Services), an interim remedial action system was installed at the Property in 2000. Detailed work scopes, procedures, and methods for these activities were presented in the *Final Interim Action Pilot Study Work Plan*, (SECOR, 1999b), *Response to Ecology's Comments Letter* (SECOR, 1999c), and the *Final Interim Action Work Plan* (SECOR, 2000a). The primary objective of the interim action was to reduce chlorinated volatile organic compound (VOC) concentrations within the areas of greatest impact and to complete cleanup of hazardous substances in these areas. The interim action consisted of two components: (1) a re-circulating system to treat groundwater; and (2) vapor extraction to treat soil. The system was designed to treat shallow groundwater (less than 45 feet deep) with PCE concentrations in excess of 1 milligram per liter (mg/L). The interim action system pumped groundwater from extraction wells installed near the river (EX-3 through EX-5), treated the pumped water with potassium permanganate, and then filtered and pumped the water into a series of injection wells along the railroad tracks (IN-1 through IN-9). For soil, an SVE system withdrew soil vapors from wells IW-1, IN-2, IN-3, IN-4, EX-1, EX-3, EX-4, and EX-5. A detailed description of the installation of the interim action system is provided in the *Final Remedial Investigation Report* (SECOR, 2001). Interim remedial action continued through 2005. The interim action successfully removed HVOC mass at the Property (based on the drop in concentration of HVOCs in some wells), but overall the system was not efficient at addressing the release area.

2.7.2 Interim Action – 2008 through Present: Combined Enhanced Bioremediation and Soil Vapor Extraction

An interim action analysis (Ash Creek, 2006) was completed in accordance with WAC 173-340-430 and WAC 173-340-360 that evaluated a range of potential alternatives for additional interim remedial action. The implemented interim action selected for the release area consisted of SVE in the vadose zone and enhanced anaerobic bioremediation of the saturated zone. The interim action was initiated in April 2008. The interim action activities were conducted in general accordance with the *Release Area Interim Action*



Design (Ash Creek, 2007). The general scope of the interim action consisted of injection of a bioremediation substrate into temporary injection points and installation/operation of an SVE system. The layout of the interim action system is shown on Figure 6, and installation is documented in the *Interim Action Installation Report* (Ash Creek, 2009b). Operation and monitoring of the interim actions is ongoing.

2.7.3 Interim Action Performance Monitoring

Performance monitoring including soil and groundwater sampling was conducted in September and October 2010. These data are reported and evaluated in the *Interim Action Performance Evaluation* report (Ash Creek, 2010c). A copy of the report is included in Appendix A. Based on the performance evaluation, the following conclusions and recommendations have been made regarding the current interim action and anticipated expanded interim action at the Property:

- ***Vadose Zone Soil***
 - The interim action SVE system is effectively removing VOC mass from the vadose zone soils. SVE should be effective within the expanded interim action area.
 - NAPL was not observed during the performance evaluation site assessment or during historical site assessment activities. However, elevated VOC concentrations are present in isolated areas of silty vadose zone soil within the existing interim action area. Elevated PCE concentrations exceed the soil saturation limit in some silty soil, indicating that it may be possible that residual NAPL is present in localized areas within the silty soil at the site. The continued operation of the SVE system will address areas of elevated VOC concentrations; however, this will involve operating the SVE system in the 2008 Interim Action area for longer than anticipated at design.
 - The expanded interim action area is not within the former product handling area, so NAPL (or isolated areas of relatively higher VOC concentrations associated with silt layers) is not anticipated to be present in vadose zone soils in the expanded area. Therefore, it is expected that SVE operations in the expanded area will exhibit classic behavior with concentrations that steadily decline to an asymptotically low value within a few years of operation. The duration of required SVE in the expanded area should be less than the current interim action.
- ***Groundwater***
 - The 2008 bioremediation injections have effectively decreased VOC concentrations in groundwater. The presence of VOCs in saturated soil within the current interim action area may continue to contribute VOCs to groundwater in the absence of further interim action. Therefore, as part of the expanded interim action, additional treatment should be completed in the source area treated in 2008.



-
- Nitrates in the interim action area are interfering with the reductive dechlorination of chlorinated solvents and have likely accelerated the use of the bioinjection substrate. Design of the oil injection volumes should account for the higher nitrate levels.
 - As discussed in the vadose zone section above, elevated concentrations of VOCs still remain in the subsurface, particularly in silty soils. However, unlike vadose zone soil being treated by SVE, the presence of relatively elevated VOC concentrations in silty soil within the saturated zone is not anticipated to slow the remediation process via enhanced bioremediation, because injected oil creates an anaerobic environment throughout the saturated zone inducing degradation in both finer and coarser grained soils. This is evidenced by the decreasing groundwater concentration trends for PCE in almost every site well.

3.0 Extent of Interim Action

This section discusses the extent of COC in soil and groundwater at the Property warranting further interim action.

3.1 Soil

The discussion of extent presented in this section focuses on vadose zone soil (generally corresponding to a depth of 25 to 30 feet). Although the standard point of compliance for soil (for protection of groundwater) is throughout the soil column, the concentrations of COC present in groundwater make differentiating between COC in saturated soil and groundwater difficult. Furthermore, actions to clean up groundwater will address saturated soil as well, so saturated soil will be addressed together with groundwater. Finally, for other potential soil cleanup levels (i.e., Method C or vapor intrusion), the point of compliance is entirely within the vadose zone.

In the FS, vadose zone soil data from the RI were compared to the cleanup levels developed in the FS. Only PCE and TCE were detected in vadose zone soil above cleanup levels. The extent of vadose zone soil with concentrations of PCE and TCE detected above cleanup levels is shown on Figure 7. The figure shows that the primary area of impact to soil is around Warehouse 13 and extending in a corridor toward the seawall. Figure 7 also shows the area of current interim action in the vadose zone soil. That portion of the vadose zone above cleanup levels that is not currently within the active or historical interim action areas will be targeted for expanded interim action.

3.2 Groundwater

The FS (Ash Creek, 2010b) presented a detailed evaluation of the extent of groundwater warranting active remedial action. A disproportionate cost analysis was used to evaluate the practicability of active groundwater cleanup. Figure 8 shows the extent of practicable active groundwater cleanup at the site as



determined in the FS. Also shown on the figure is the extent of the current interim action in groundwater. The area of practicable active groundwater cleanup is targeted for treatment in the expanded interim action. The interim action performance evaluation (see Section 2.7.3) indicates that further treatment in the source area would be beneficial. The expanded interim action will include additional injection within the source interim action area.

4.0 Design Analysis – Soil Vapor Extraction

The *Interim Action Analysis* (Ash Creek, 2006) and FS (Ash Creek, 2010b) identified SVE as the technology to address VOCs in the vadose soil at the Property. The layout and size of the SVE components is dependent on the surface cover, soil type, depth to groundwater (the thickness of the vadose zone), and horizontal and vertical extent of the target VOCs. The Interim Action Analysis (Ash Creek, 2006) provided detailed evaluation of the design components of the SVE system. In addition, the source area interim action has been operating since September 2008. As discussed in Section 2.7.3, based on the performance of the current interim action SVE system, SVE should be effective in the expanded interim action area.

Based on the prior design analysis and performance of the existing interim action system, a similar design will be used for the interim action expansion. In summary, the well design parameters are:

- Air flow rate of 25 cubic feet per minute (cfm) per extraction well;
- Well spacing of 30 feet;
- Well screen extending from 5 to 25 feet bgs (two wells each with 10-foot screens at each location to better assure uniform flow over full well depth); and
- Ground surface covered with pavement.

A total of 17 vapor extraction locations are required to cover the expanded treatment area, as shown on Figure 9. The wells will be configured into five groupings with three to four well locations per group. Each group will be connected to a single branch connecting to a header pipe through a valve. Between the existing and new wells, there will be a total of 10 branches (each with three to four well locations) for a total of 34 well locations.

Blower. In general, the existing blower is suitable for operating both the existing and expanded SVE system, although operation would be conducted on a rotating basis with only a portion of the branches operating at any one time. However, the under-rail crossing for the piping is at capacity, so two blowers will be used, one on each side of the railroad. Because eight of the 10 branches are on the south side of the tracks, the existing blower will be relocated to the south side of the tracks and connected to those eight branches. A new, lower-capacity blower will be installed in the existing treatment area.



Piping Selection. Piping has been sized for ease of installation and so that the pressure drop (friction losses) through the pipe is less than one inch of water per 100 feet of pipe. Friction losses were estimated from the friction loss equation for turbulent air flow in a pipe ($\Delta P = 0.109136Q^{1.9} / d^{5.02}$, where ΔP is the pressure drop over 100 feet of pipe, Q is the flow rate in cubic feet per minute, and d is the pipe diameter in inches). Well diameters were set at not more than 2 inches to allow installation using direct-push techniques. Pipe diameters are maintained over the length of each branch to simplify installation and reduce the potential for vacuum leaks at pipe junctions.

The selected piping diameters are:

Location	Diameter (inches)
At each vapor extraction well	2
Each manifold zone (3 or 4 wells)	4
Main header	8

The piping will consist of Schedule 80 PVC to resist damage from heavy traffic and during installation. The concentrations of vapors in the operating airflow are not expected to adversely affect the PVC material during the operating life of the system.

Vapor Treatment. Activated carbon will be used to remove VOCs from the air stream prior to discharge into the atmosphere (other removal technologies, such as catalytic or thermal oxidation, are complicated by the concentrations of chlorinated solvent hydrocarbons, which would produce hydrochloric acid as a byproduct of the oxidation). The existing carbon vessels (two 1,500-pound vapor carbon vessels) will be relocated to the south side of the railroad with the existing blower. These vessels are sized to accommodate the required air flow and to reasonably limit the frequency of carbon replacement. Two vapor carbon vessels are present in series to allow full saturation of the lead carbon prior to replacement. Vapor monitoring will continue to be conducted before, between, and after the carbon vessels to verify efficient use of the carbon but also compliance with discharge limitations. The existing carbon vessels accommodate the design flow rate of up to 450 cfm with a head loss of less than 5 inches of water each.

Carbon treatment will not be installed on the new, lower-capacity blower to be installed at the existing treatment system. Based on recent monitoring, concentrations of emissions at potential exposure points are estimated to be at or below acceptable risk-based concentrations for industrial receptors.

Based on the performance of the existing interim action system, the initial carbon usage rate is expected to be not greater than 3,000 pounds of carbon in 60 days (50 pounds per day). This rate is expected to drop to 15 pounds per day (3,000 pounds in six months) within three months of startup, and will likely remain at similar levels until the higher concentrations in the silt lenses are depleted. Usage for vapors extracted from the expanded interim action area is expected to continue to decrease with time.

Expected Operation Period. In general, soil conditions in the vadose zone of the expanded interim action area are similar to the current interim action area and concentrations of VOCs are lower. The soils consist primarily of sand with occasional silt layers. However, the soils in the expanded interim action area also include some gravel and concrete debris, and there appears to be fewer silt layers relative to the existing interim action area. Therefore, the operation period for the SVE system in the expanded interim action area is expected to be shorter than for the existing interim action area. To date, the SVE system in the existing interim action area has operated for approximately 2.5 years, and except for the a few silt layers, cleanup of the vadose zone is essentially complete. It is expected that cleanup of the expanded interim action area should require on the order of 2 years of operational time. Accounting for on/off cycling of various branches, the total operation time in the expanded area is expected to be approximately 3 years.

System Design. The design for the SVE system is included in Appendix B.

5.0 Design Analysis – Enhanced Bioremediation

The *Interim Action Analysis* (Ash Creek, 2006) and FS (Ash Creek, 2010b) identified *in situ* enhanced bioremediation (anaerobic reductive dechlorination) as the technology to address volatile organics in the groundwater and saturated soil of the Shallow Zone treatment area (from the top of the groundwater table to a nominal depth of 45 to 50 feet). The *Interim Action Analysis* (Ash Creek, 2006) provided detailed evaluation of the design components of the enhanced bioremediation system. In addition, the source area interim action has been operating since May 2008. As discussed in Section 2.7.3, based on the performance of the current interim action system, enhanced bioremediation should be effective in the expanded interim action area, though the presence of nitrate across the treatment area does increase the mass of bioremediation substrate needed to reach the intended effectiveness.

Based on the prior design analysis and performance of the existing interim action system, the same process will be used for the interim action expansion. The following discusses the conditions within the expanded interim action area (see Figure 8) to support the injection strategy.

Soil Profile. The saturated zone soil in the expanded interim action area is generally characterized by a medium sand (with occasional lenses of silty sand or silt) that extends from the top of the water table (a nominal depth of 25 feet) to the bottom of the shallow aquifer. At 40 to 50 feet bgs, a layer of silt and silty gravel separate the overlying medium sand (Shallow Zone) from an underlying gravel unit (Intermediate Zone). Figure 3 shows a cross section through the vicinity of the treatment area. Aquifer testing completed during previous work at the Facility indicates a hydraulic conductivity on the order of 0.01 cm/sec for the shallow aquifer.

Chemical Profile. Within the expanded interim action area, PCE concentrations ranged from non-detect to 4 milligrams per kilogram (mg/kg) in the soil, and 0.01 to 9.8 mg/L in groundwater. TCE concentrations



ranged from non-detect to 0.57 mg/kg in soil, and non-detect to 4.1 mg/L in groundwater. The relatively highest concentrations of PCE and TCE in the saturated zone were found at depths of between 35 and 45 feet bgs.

Selected Injection Substrate and Quantity. The selected injection substrate for the interim action expansion is an emulsified oil substrate manufactured by EOS Remediation, Inc., of Raleigh, North Carolina. The EOS® electron donor consists of a blend of fast- and slow-release electron donors in a micro-emulsion form with uniform droplets significantly smaller than soil pore spaces. EOS® is an emulsified oil product that includes easily biodegradable substrate (e.g., sodium lactate) and slowly degradable substrates (e.g., edible oil). The sodium lactate in the solution stimulates microbial growth and rapidly produces anaerobic conditions in the subsurface. After the lactate has been consumed, the less-soluble vegetable oil portion of the product is retained on the soil surfaces and pore spaces. The vegetable oil slowly ferments to release volatile fatty acids and molecular hydrogen, which support the anaerobic microbial community. The EOS vendor estimates a default lifetime of 5 years for their product. This default value is used to estimate the quantity of product needed, so assuming a longer lifetime is conservative (i.e., results in a greater estimate of product needed). Actual product lifetime is typically less than five years. Based on data collected to evaluate the performance of the injections in the source area interim action (see Appendix A), those initial injections may be nearing completion after approximately 2.5 years, but this may be partially the result of higher than expected nitrate levels. Accounting for these higher nitrate levels, the expected lifetime of the EOS substrate is on the order of 3 years.

This product was selected over the previously used whole-oil substrate based on recent groundwater monitoring that has demonstrated nitrate concentrations higher than levels detected prior to the previous interim action. Nitrate concentrations were detected in October 2010 up to 990 mg/L in monitoring well MP-1 with an average of 320 mg/L, compared to an average of 140 mg/L from 2007 data. Based on an evaluation using vendor application models, the EOS product provides overall better results under these changed conditions.

The total volume of substrate to be injected was estimated using the vendor-supplied calculation tool that accounts for both the stoichiometric hydrogen demand of the chemicals (from both the targeted contaminants such as PCE and interfering compounds such as nitrates and sulfates) and the physical limitations of the soil matrix. Appendix C includes the calculation of the amount of substrate to be injected. A total of 92,000 pounds (210 drums) of EOS substrate will be injected for the expanded interim action.

Injection Strategy. To distribute the EOS substrate evenly throughout the proposed treatment area, the injections are generally spaced equidistantly with alternate rows offset by half of the spacing. Outside the source area, the spacing was set at 25 feet (based on an estimated 50-foot zone of potential impact and a factor of safety of two, as described in the Department of Defense ESTCP *Protocol for Enhanced In Situ Bioremediation Using Emulsified Edible Oil*; DOD, 2006). To provide more continuous coverage in the



source area (the area of the current interim action), the spacing between points is reduced by half (to a distance of 12.5 feet). To prevent the substrate injection from potentially impacting the adjacent surface water, injections will not be done within 100 feet of the riverbank (based on the above estimated 50-foot zone of potential impact and a factor of safety of two). The corresponding layout, accommodating obstructions and the overlap between the standard injection spacing and the source area injections, results in a total of 155 injection points. Specifically, there are 46 injection points in the source area and 109 injection points outside of the source area. The layout of the proposed injections is shown on Figure 10 and is presented in the design drawings in Appendix D.

In general, substrate will be injected in the saturated zone over the depth range corresponding to the Shallow Zone. Actual injection depths will be determined at the time of injection. The upper limit will correspond to the top of the water table as determined by the depth to groundwater in monitoring wells within the injection area (generally expected to be on the order of 30 feet). The lower limit is determined by the depth to the silty gravel layer separating the Shallow and Intermediate Zones on the property. Based on prior probe work, the lower limit depth will vary from 42 to 55 feet with most injections being in the 45- to 50-foot depth range. For planning purposes, the injection depths have been assumed to be between 30 to 50 feet, except that injections nearest the river have been assumed to be between 30 to 55 feet.

Delivery Method. The injection points will be completed using direct-push technology. An injection probe tip will be advanced to the pre-designated depth at each injection location, withdrawn in 5-foot intervals, and emulsified oil will be injected through the drill stem via an air diaphragm pump. This process is repeated until the full depth of the injection boring is complete.

Solution Preparation/Injection Volume. The EOS[®] emulsified oil concentrate will be diluted with water obtained from the municipal water supply and dechlorinated using a purpose-specific commercial additive (such as sodium thiosulfate). Injections outside the source area will be diluted at a ratio of approximately 10 to 1, and injections within the source area will be diluted at a ratio of 20 to 1 (such that at the spacing discussed above, the same mass of substrate will be delivered per unit treated volume). The total solution volume will be approximately 147,000 gallons. Two 1,000-gallon polyethylene tanks will be used to allow mixing and injection to be performed simultaneously. Mixing of the solution will be accomplished by combining the EOS[®] concentrate with water and stirring with a recirculation pump.

Injection Rate. For the typical injection point outside the source area, approximately 240 gallons of prepared emulsified solution will be injected per 5-foot vertical zone, for a total of approximately 960 gallons of solution injected per location. The source-area injections will receive approximately 230 gallons of solution per 5-foot zone (but at a higher dilution of water to substrate of 20:1), increasing the potential for the solution to directly contact soil with higher relative source area concentrations. For the injection locations nearest the river, the injection thickness is slightly larger (up to about 25 feet) but the lower concentrations of VOCs and nitrates in this area require less substrate mass. Each of these points will receive the same

total volume per injection of 960 gallons (though at 190 gallons per 5-foot zone). In the event that the target depth cannot be achieved because of equipment refusal, the solution will be evenly distributed over the depth range of 25 feet to the actual depth achieved. The initial targeted injection rate is 10 to 20 gallons per minute. The required net injection pressure depends on several factors such as losses in the piping, hydraulic conductivity of the soil, and static water pressure at the injection depth. At the injection depths, the soils consist predominantly of sand so short circuiting along the drill string is anticipated to be minimal.

Abandonment. The injection borings will be abandoned in accordance with OWRD regulations and procedures. The abandonment procedure will consist of pressure-grouting the injection from the bottom up with a high-solids bentonite slurry pumped through a tremie pipe/probe rod set at the bottom of the hole.

Expected Performance Results. The enhanced bioremediation technology is capable of complete destruction of the target compounds (chlorinated VOCs). This has been demonstrated in both laboratory and field applications. The ability to achieve complete destruction depends on a number of factors such as presence of appropriate bacteria, presence of nutrients, ability to achieve and maintain anaerobic conditions, and presence of competing electron acceptors. Usually, the primary factor affecting the ability to achieve complete destruction is the ability to effectively mix the aqueous phase dissolved target compounds with the biosubstrate. Higher concentrations of VOCs in silt layers may not have sufficient contact with the substrate within the effective lifetime of the substrate for complete destruction. These pockets of remaining VOCs can then act as a source for some level of rebound of dissolved phase concentrations of VOCs. For the existing interim action injections in the source area, the average total molar concentration of chlorinated VOCs within the injection area has been reduced by approximately 80 percent (see Appendix A). Complete destruction was not achieved (although further reduction is still possible) likely because of the higher than expected nitrates and because of relatively higher concentrations of VOCs remaining in silt layers within the treatment zone. The presence of higher concentrations in silt zones was anticipated and additional injection within the source area was expected to be required. The proposed injection strategy should be effective in establishing an anaerobic environment in the targeted saturated zone that will be suitable for bioremediating the VOCs present within *both* the finer and courser grained soils in the saturated zone. Given the performance to date, consideration of the higher nitrate levels, and distribution of VOCs, it is expected that average reductions in chlorinated VOCs within the treatment area should be on the order of 90 percent, with nearly complete destruction possible outside of the source area.

6.0 Schedule

To minimize the interference of the two operations intended for the treatment area (installation of the SVE wells and piping in the vadose zone and the bioremediation injection in the saturated zone), the bioremediation injection effort would be completed first – an effort that is expected to have a duration of 16 to 32 days, depending on the achievable injection rate. These injections could begin within 3 weeks of a notice to proceed (based on the vendor's estimate of needed lead-time to deliver the product). The injection



schedule would need to be coordinated with Facility personnel as the work will be completed within areas of terminal operations and in the vicinity of area roadways and rail spurs.

The installation of the SVE system components would generally follow the bioremediation injections, though the work can overlap with the SVE drilling and pipe installations being done in areas where the bioremediation injections are complete. The SVE system expansion is expected to take two to four weeks to install.



7.0 References

- Ash Creek Associates, 2006. *Interim Action Analysis Report, ST Services, Vancouver, Washington*. November 28, 2006.
- Ash Creek Associates, 2007. *Release Area Interim Action Design, ST Services, Vancouver, Washington*. May 28, 2007.
- Ash Creek Associates, 2008. *Baseline Risk Assessment Report, NuStar Vancouver Main Terminal, Vancouver, Washington*. September 4, 2008.
- Ash Creek Associates, 2009a. *Revised Remedial Investigation Report, NuStar Terminals Services, Inc., Vancouver Main Terminal, Vancouver, Washington*. October 1, 2009.
- Ash Creek Associates, 2009b. *Interim Action Installation Report, NuStar Terminals Services, Inc. Vancouver, Washington*. May 5, 2009.
- Ash Creek, 2010a. *Transducer Installation Work Plan. NuStar Vancouver Facility, Vancouver, Washington*. September 11, 2010.
- Ash Creek, 2010b. *Feasibility Study, NuStar Terminals Services, Inc., Vancouver Main Terminal, Vancouver, Washington (DRAFT)*. January 14, 2010.
- Ash Creek, 2010c. *Interim Action Performance Evaluation Report*. November 30, 2010. (Appendix A of this Work Plan).
- DOD, 2006. *Protocol for Enhanced In Situ Bioremediation Using Emulsified Edible Oil*, Department of Defense ESTCP – Solutions IES, March 2006.
- Parametrix, 2008. *Vancouver Lake Lowlands Groundwater Model Summary Report*. February 15, 2008.
- SECOR International, Inc., 1999a. Report unable to be located.
- SECOR International, Inc., 1999b. *Final Interim Action Pilot Study Work Plan*. January 20, 1999.
- SECOR International, Inc., 1999c. *Response to Ecology's Comments Letter*. June 24, 1999.
- SECOR International, Inc., 2000a. *Final Interim Action Work Plan*. April 7, 2000.
- SECOR International, Inc., 2001. *Final Remedial Investigation Report, Vancouver Terminal, Port of Vancouver Terminal No. 2, Vancouver, Washington*. October 19, 2001.



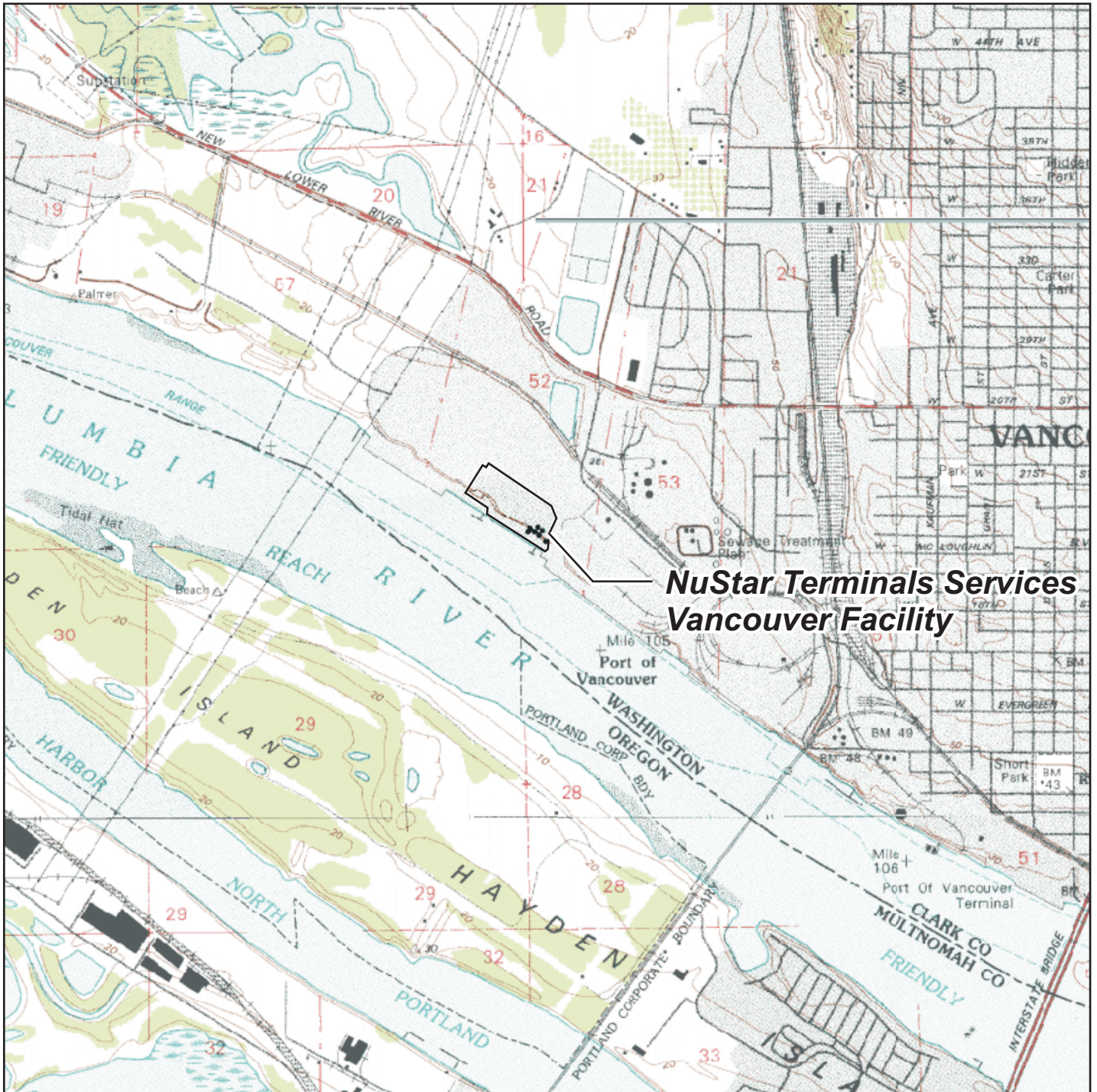

NOTES: 1) Base map prepared from USGS 7.5-minute quadrangles as provided by Topozone.
 2) Property defined based on 2006 leasehold boundary.



Property Location Map

2010 Interim Action Work Plan
 NuStar Terminals Services, Inc. Vancouver Facility
 Vancouver, Washington

 Ash Creek Associates, Inc.
 Environmental and Geotechnical Consultants

Project Number	1126-09
March 2011	

Figure	1
--------	---

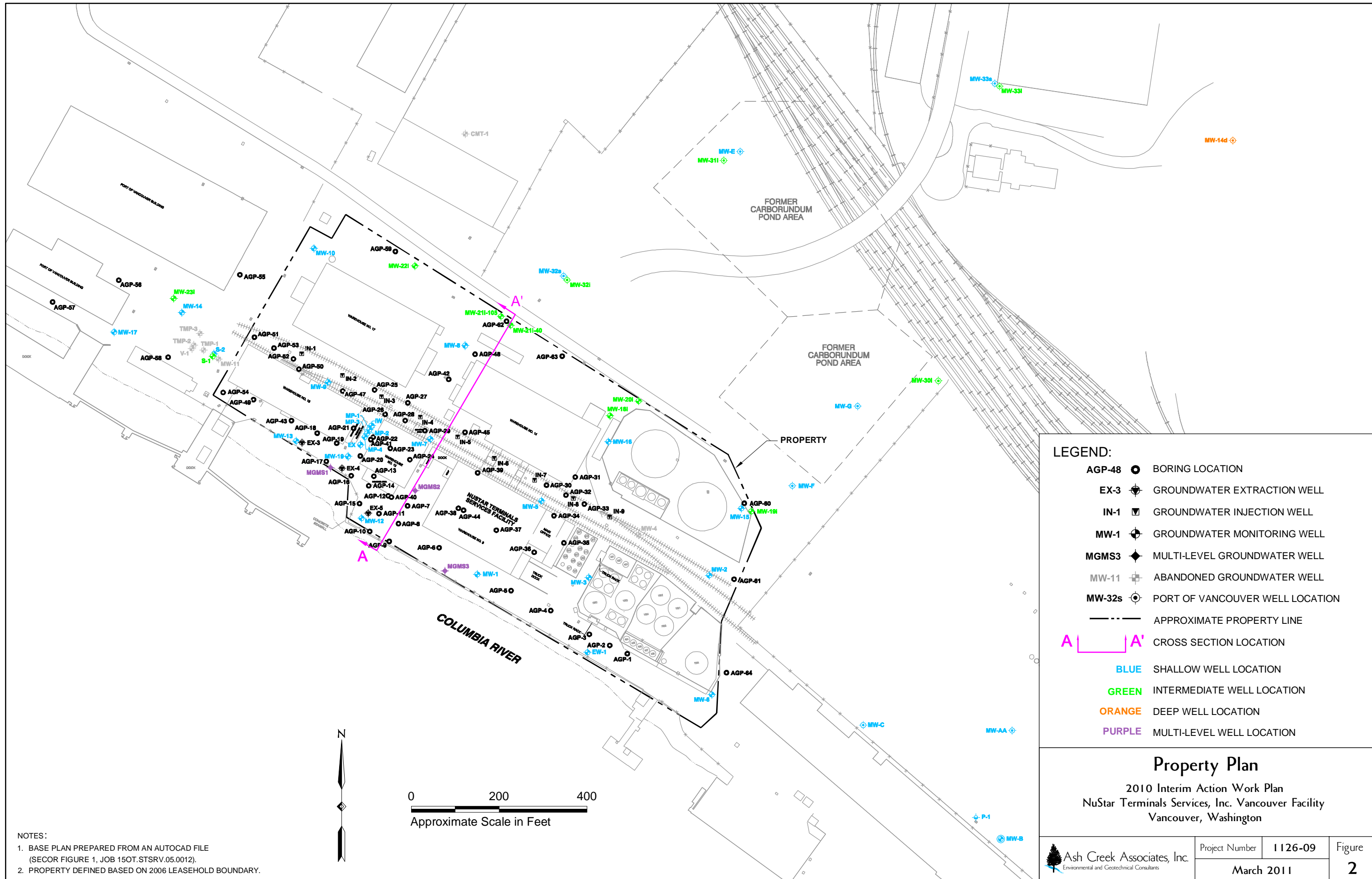

LEGEND:

- AGP-48 ● BORING LOCATION
- EX-3 ⚡ GROUNDWATER EXTRACTION WELL
- IN-1 ▣ GROUNDWATER INJECTION WELL
- MW-1 ⚡ GROUNDWATER MONITORING WELL
- MGMS3 ⚡ MULTI-LEVEL GROUNDWATER WELL
- MW-11 ⚡ ABANDONED GROUNDWATER WELL
- MW-32s ⚡ PORT OF VANCOUVER WELL LOCATION
- APPROXIMATE PROPERTY LINE
- A A' CROSS SECTION LOCATION
- BLUE SHALLOW WELL LOCATION
- GREEN INTERMEDIATE WELL LOCATION
- ORANGE DEEP WELL LOCATION
- PURPLE MULTI-LEVEL WELL LOCATION

Property Plan
 2010 Interim Action Work Plan
 NuStar Terminals Services, Inc. Vancouver Facility
 Vancouver, Washington

NOTES:
 1. BASE PLAN PREPARED FROM AN AUTOCAD FILE (SECOR FIGURE 1, JOB 15OT.STSRV.05.0012).
 2. PROPERTY DEFINED BASED ON 2006 LEASEHOLD BOUNDARY.

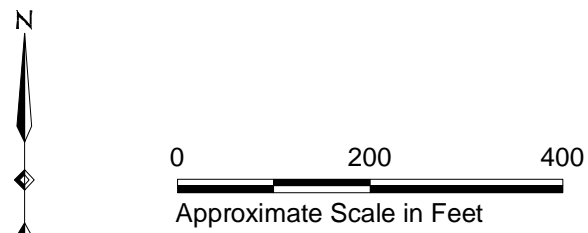

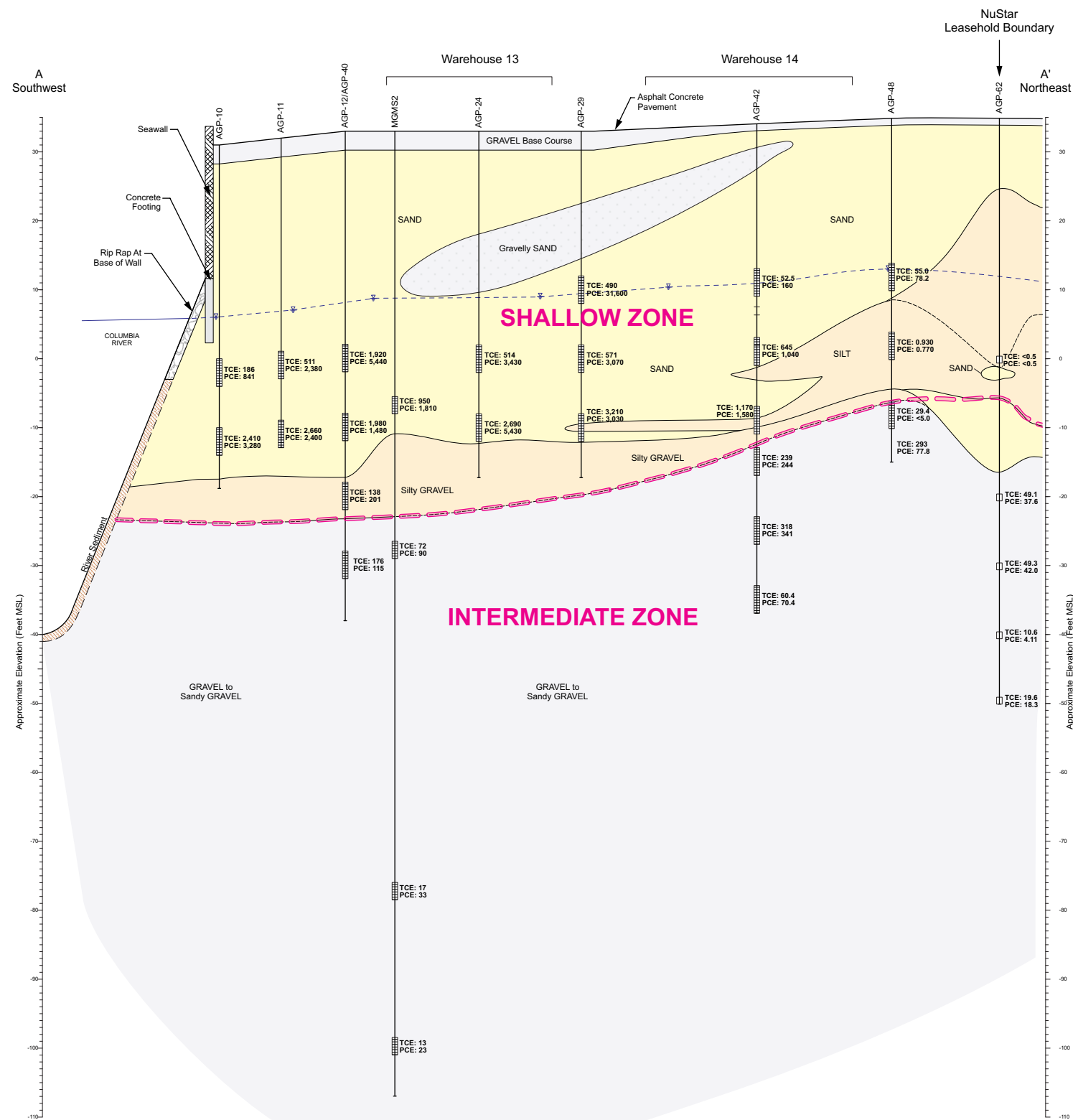

Legend:

- Borehole
 - Water Level (At Time of Drilling)
 - Trichloroethene (TCE) Concentration in µg/L
Tetrachloroethene (PCE) Concentration in µg/L
 - Screened Interval
 - Depth Discrete Sample Location
 - Approximate Boundary Between Shallow and Intermediate Zone
- NOTE: Mean Sea Level (MSL) referenced to NGVD29/47 Datum.

GEOLOGIC DESCRIPTIONS:

- SAND:** Sands, ranging in color from reddish brown to dark brown to gray. Fine to very coarse grained. Poorly graded to well graded and poorly sorted to well sorted. Primarily basaltic and micaceous. Found with trace clays and gravels, and/or thin silt layers.
- SILT:** Silts, silts with sands, sandy silts, gravelly sandy silts and clayey silts. Color ranging from reds and tans, to grays, browns and black, frequently mottled. Soft to medium stiff, clayey silts ranging from soft to moderate plasticity. fine to coarse sands.
- Gravelly SANDS:** Gravelly sand to sand with gravel. Color ranging from reds to brown or black. Fine to coarse sands that are poorly graded to well graded. Clasts are well rounded to angular, up to six inches in diameter. Basaltic and micaceous with trace silts.
- GRAVEL:** Gravels with sand to sandy gravels. Color ranging from gray to black. Silty sandy matrix with trace clays. Fine to coarse grained, loose to partial cementation. Poorly graded to well graded. Clasts range from well rounded to angular. Basaltic with trace quartzite gravels.
- River Sediment**

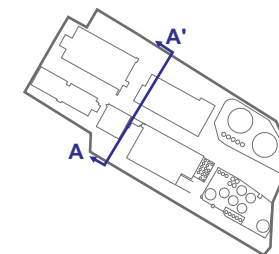

Cross Section Location

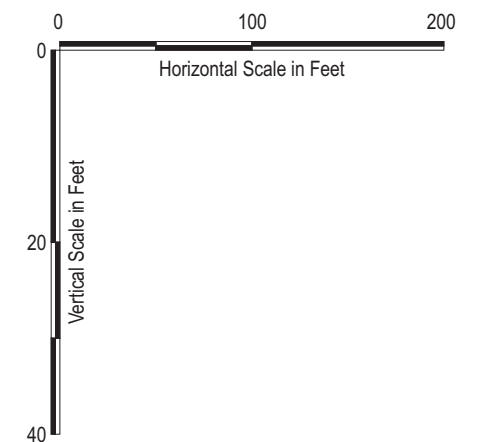

Geologic Cross-Section A-A'

2010 Interim Action Work Plan
NuStar Terminals Services, Inc. Vancouver Facility
Vancouver, Washington

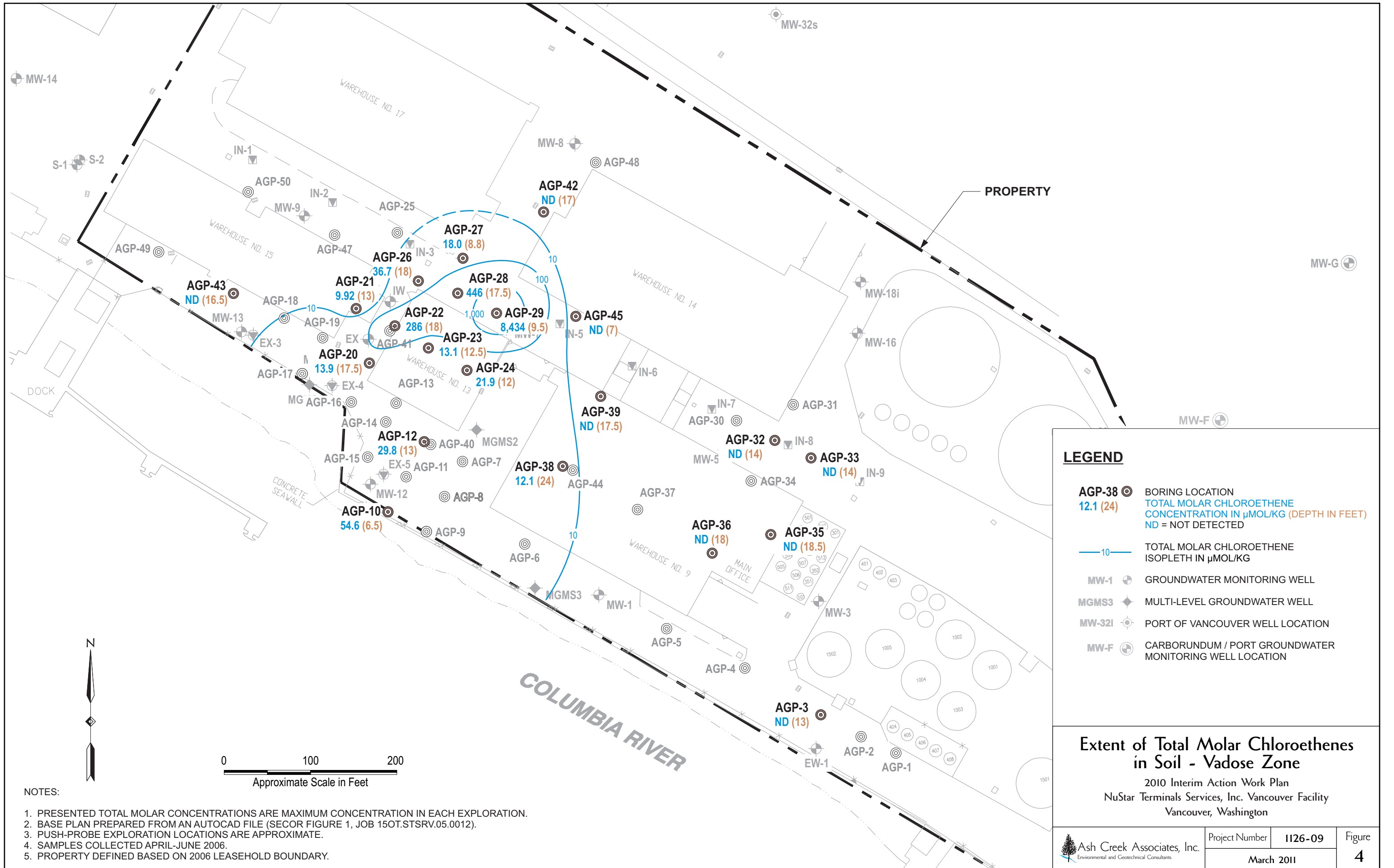

LEGEND

- AGP-38** ● BORING LOCATION
- 12.1 (24) TOTAL MOLAR CHLOROETHENE CONCENTRATION IN µMOL/KG (DEPTH IN FEET)
- ND = NOT DETECTED
- 10— TOTAL MOLAR CHLOROETHENE ISOPLETH IN µMOL/KG
- MW-1 ● GROUNDWATER MONITORING WELL
- MGMS3 ◆ MULTI-LEVEL GROUNDWATER WELL
- MW-32i ● PORT OF VANCOUVER WELL LOCATION
- MW-F ● CARBORUNDUM / PORT GROUNDWATER MONITORING WELL LOCATION

Extent of Total Molar Chloroethenes in Soil - Vadose Zone
 2010 Interim Action Work Plan
 NuStar Terminals Services, Inc. Vancouver Facility
 Vancouver, Washington

- NOTES:
1. PRESENTED TOTAL MOLAR CONCENTRATIONS ARE MAXIMUM CONCENTRATION IN EACH EXPLORATION.
 2. BASE PLAN PREPARED FROM AN AUTOCAD FILE (SECOR FIGURE 1, JOB 15OT.STSRV.05.0012).
 3. PUSH-PROBE EXPLORATION LOCATIONS ARE APPROXIMATE.
 4. SAMPLES COLLECTED APRIL-JUNE 2006.
 5. PROPERTY DEFINED BASED ON 2006 LEASEHOLD BOUNDARY.

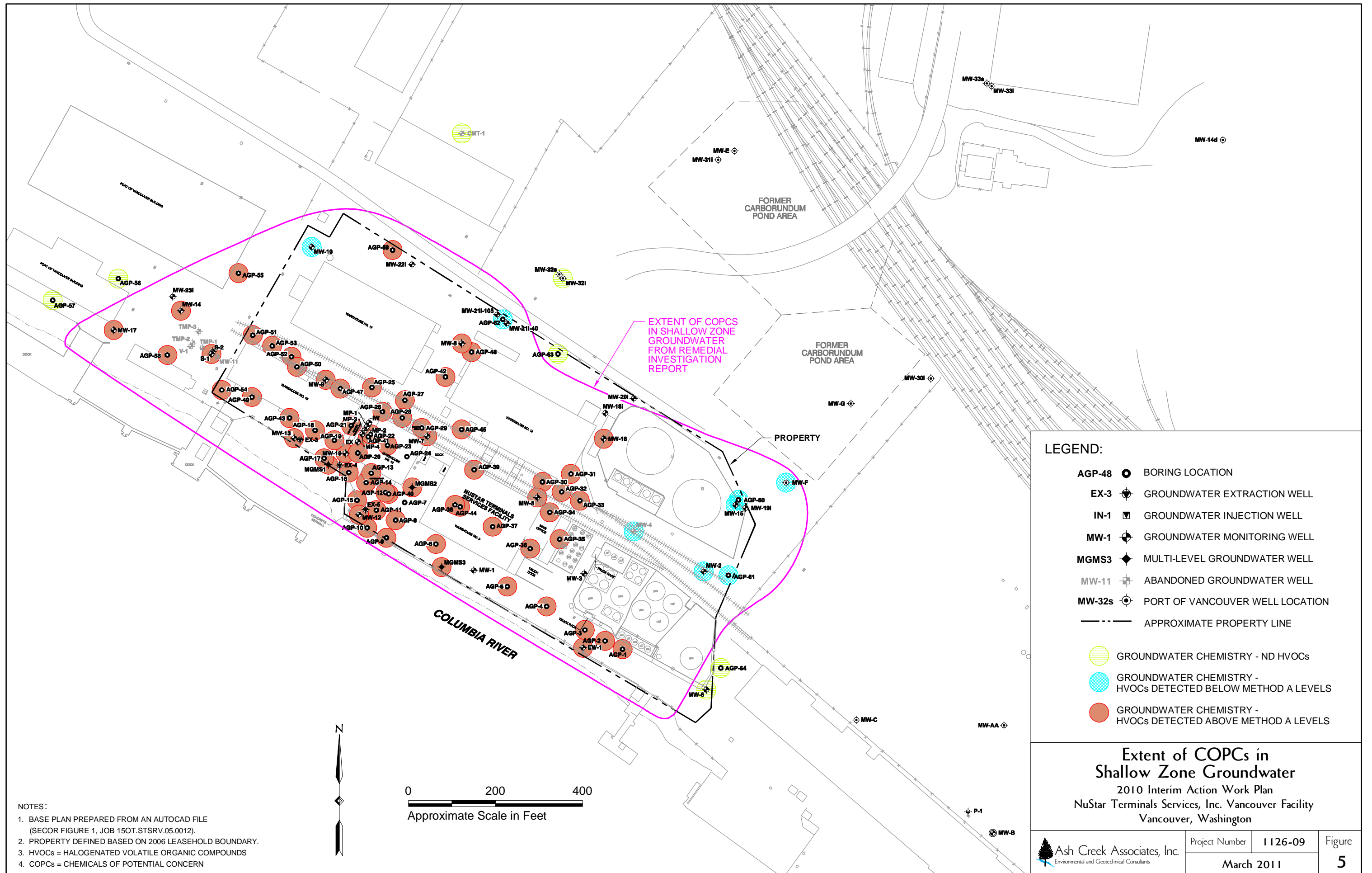

EXTENT OF COPCS
IN SHALLOW ZONE
GROUNDWATER
FROM REMEDIAL
INVESTIGATION
REPORT

LEGEND:

- AGP-48 ● BORING LOCATION
- EX-3 ⚡ GROUNDWATER EXTRACTION WELL
- IN-1 ▣ GROUNDWATER INJECTION WELL
- MW-1 ⚡ GROUNDWATER MONITORING WELL
- MGMS3 ⚡ MULTI-LEVEL GROUNDWATER WELL
- MW-11 ⚡ ABANDONED GROUNDWATER WELL
- MW-32s ⚡ PORT OF VANCOUVER WELL LOCATION
- APPROXIMATE PROPERTY LINE
- GROUNDWATER CHEMISTRY - ND HVOCs
- GROUNDWATER CHEMISTRY - HVOCs DETECTED BELOW METHOD A LEVELS
- GROUNDWATER CHEMISTRY - HVOCs DETECTED ABOVE METHOD A LEVELS

**Extent of COPCs in
Shallow Zone Groundwater**
2010 Interim Action Work Plan
NuStar Terminals Services, Inc. Vancouver Facility
Vancouver, Washington

- NOTES:**
1. BASE PLAN PREPARED FROM AN AUTOCAD FILE (SECOR FIGURE 1, JOB 150T.STSRV.05.0012).
 2. PROPERTY DEFINED BASED ON 2006 LEASEHOLD BOUNDARY.
 3. HVOCs = HALOGENATED VOLATILE ORGANIC COMPOUNDS
 4. COPCS = CHEMICALS OF POTENTIAL CONCERN

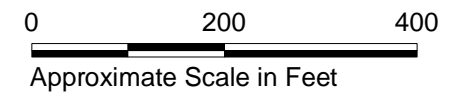

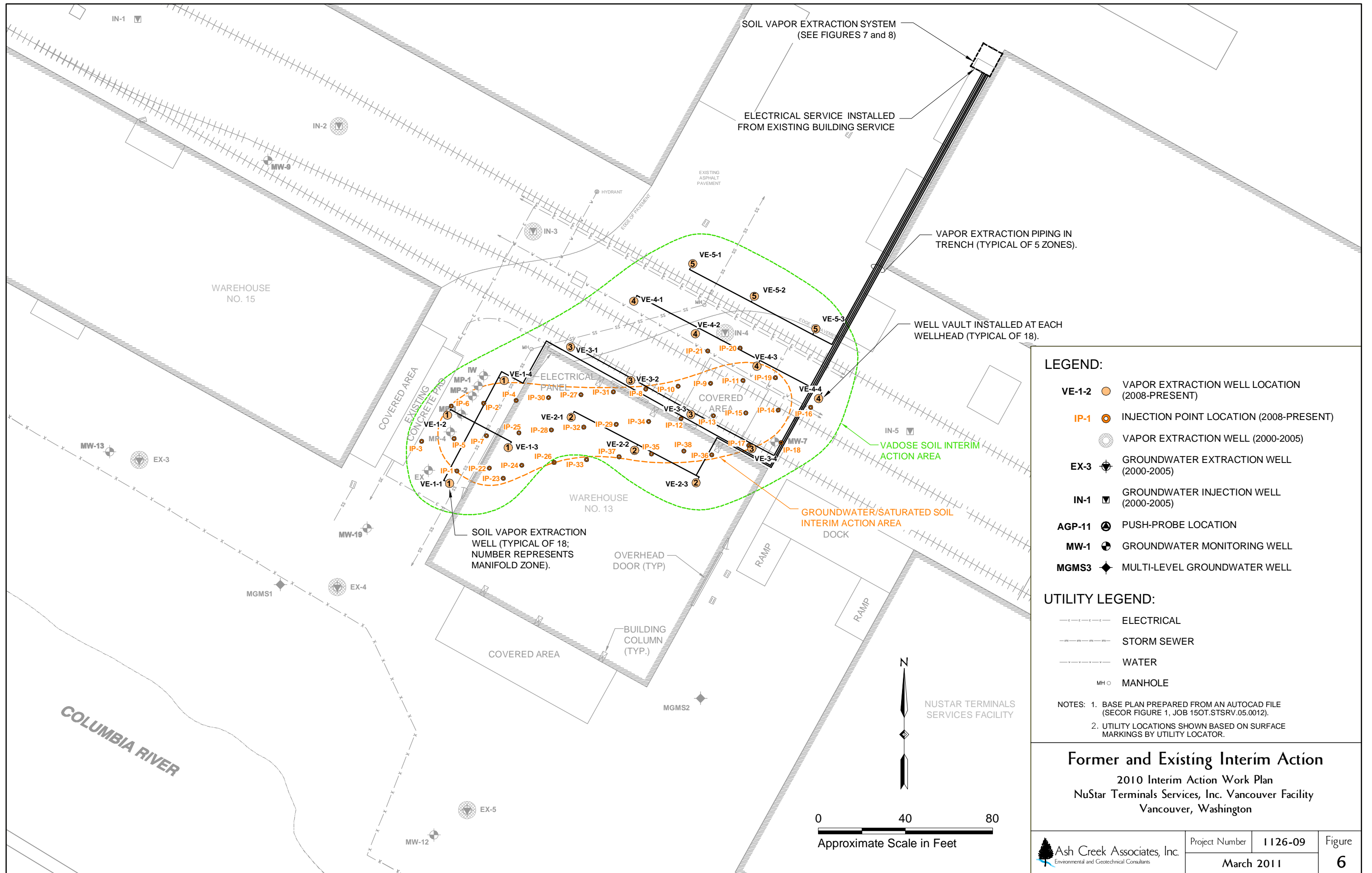

- LEGEND:**
- VE-1-2 ○ VAPOR EXTRACTION WELL LOCATION (2008-PRESENT)
 - IP-1 ○ INJECTION POINT LOCATION (2008-PRESENT)
 - VAPOR EXTRACTION WELL (2000-2005)
 - EX-3 ⊕ GROUNDWATER EXTRACTION WELL (2000-2005)
 - IN-1 ▽ GROUNDWATER INJECTION WELL (2000-2005)
 - AGP-11 ⊙ PUSH-PROBE LOCATION
 - MW-1 ⊕ GROUNDWATER MONITORING WELL
 - MGMS3 ⊕ MULTI-LEVEL GROUNDWATER WELL

- UTILITY LEGEND:**
- ELECTRICAL
 - STORM SEWER
 - WATER
 - MH ○ MANHOLE
- NOTES: 1. BASE PLAN PREPARED FROM AN AUTOCAD FILE (SECOR FIGURE 1, JOB 150T.STSRV.05.0012).
 2. UTILITY LOCATIONS SHOWN BASED ON SURFACE MARKINGS BY UTILITY LOCATOR.

Former and Existing Interim Action
 2010 Interim Action Work Plan
 NuStar Terminals Services, Inc. Vancouver Facility
 Vancouver, Washington

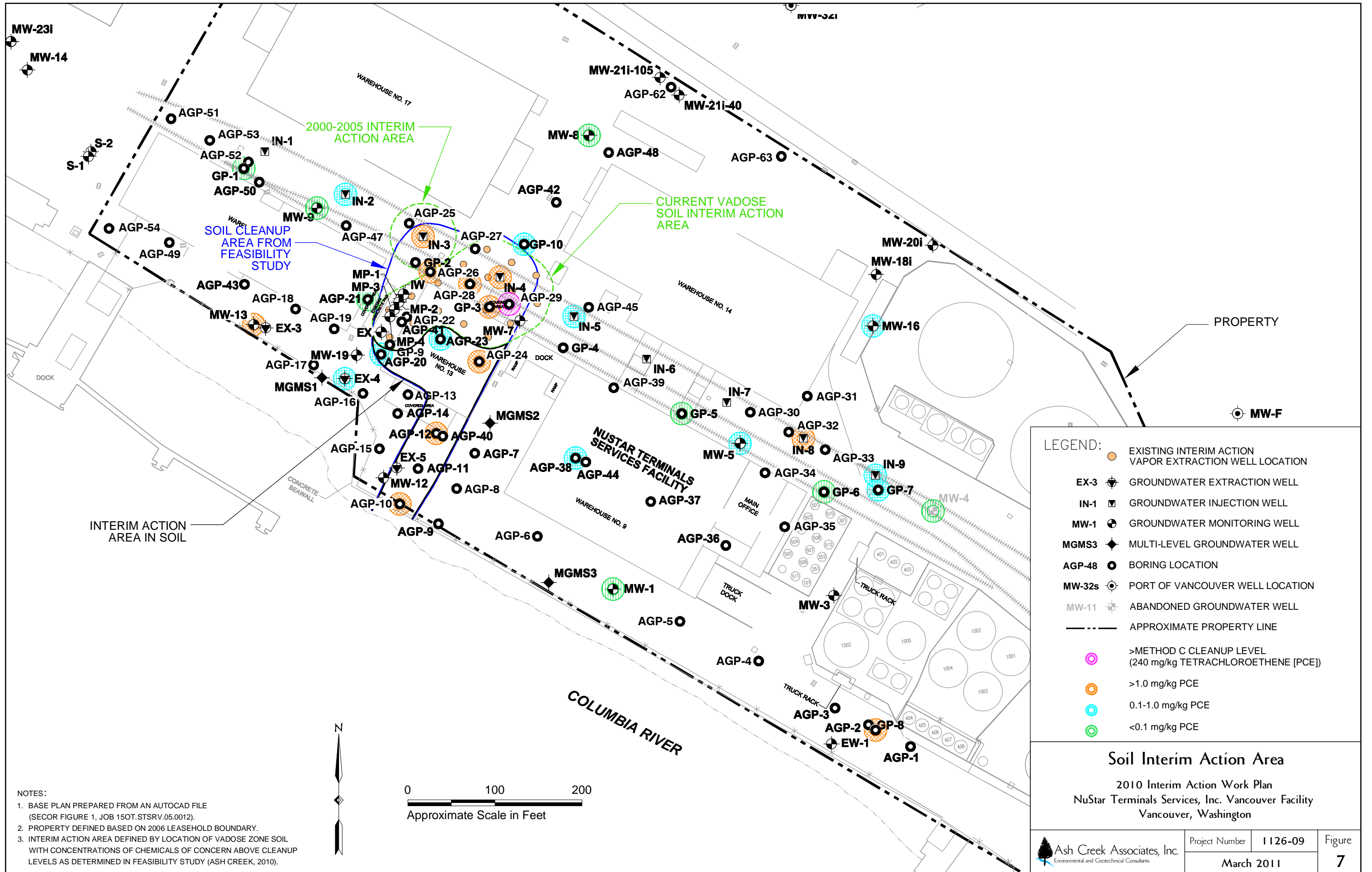

NOTES:

1. BASE PLAN PREPARED FROM AN AUTOCAD FILE (SECOR FIGURE 1, JOB 150T.STSRV.05.0012).
2. PROPERTY DEFINED BASED ON 2006 LEASEHOLD BOUNDARY.
3. INTERIM ACTION AREA DEFINED BY LOCATION OF VADOSE ZONE SOIL WITH CONCENTRATIONS OF CHEMICALS OF CONCERN ABOVE CLEANUP LEVELS AS DETERMINED IN FEASIBILITY STUDY (ASH CREEK, 2010).

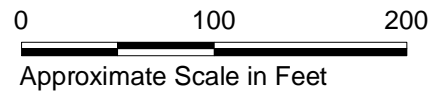

LEGEND:

- EXISTING INTERIM ACTION VAPOR EXTRACTION WELL LOCATION
- EX-3 GROUNDWATER EXTRACTION WELL
- IN-1 GROUNDWATER INJECTION WELL
- MW-1 GROUNDWATER MONITORING WELL
- MGMS3 MULTI-LEVEL GROUNDWATER WELL
- AGP-48 BORING LOCATION
- MW-32s PORT OF VANCOUVER WELL LOCATION
- MW-11 ABANDONED GROUNDWATER WELL
- APPROXIMATE PROPERTY LINE
- >METHOD C CLEANUP LEVEL (240 mg/kg TETRACHLOROETHENE [PCE])
- >1.0 mg/kg PCE
- 0.1-1.0 mg/kg PCE
- <0.1 mg/kg PCE

Soil Interim Action Area

2010 Interim Action Work Plan
 NuStar Terminals Services, Inc. Vancouver Facility
 Vancouver, Washington

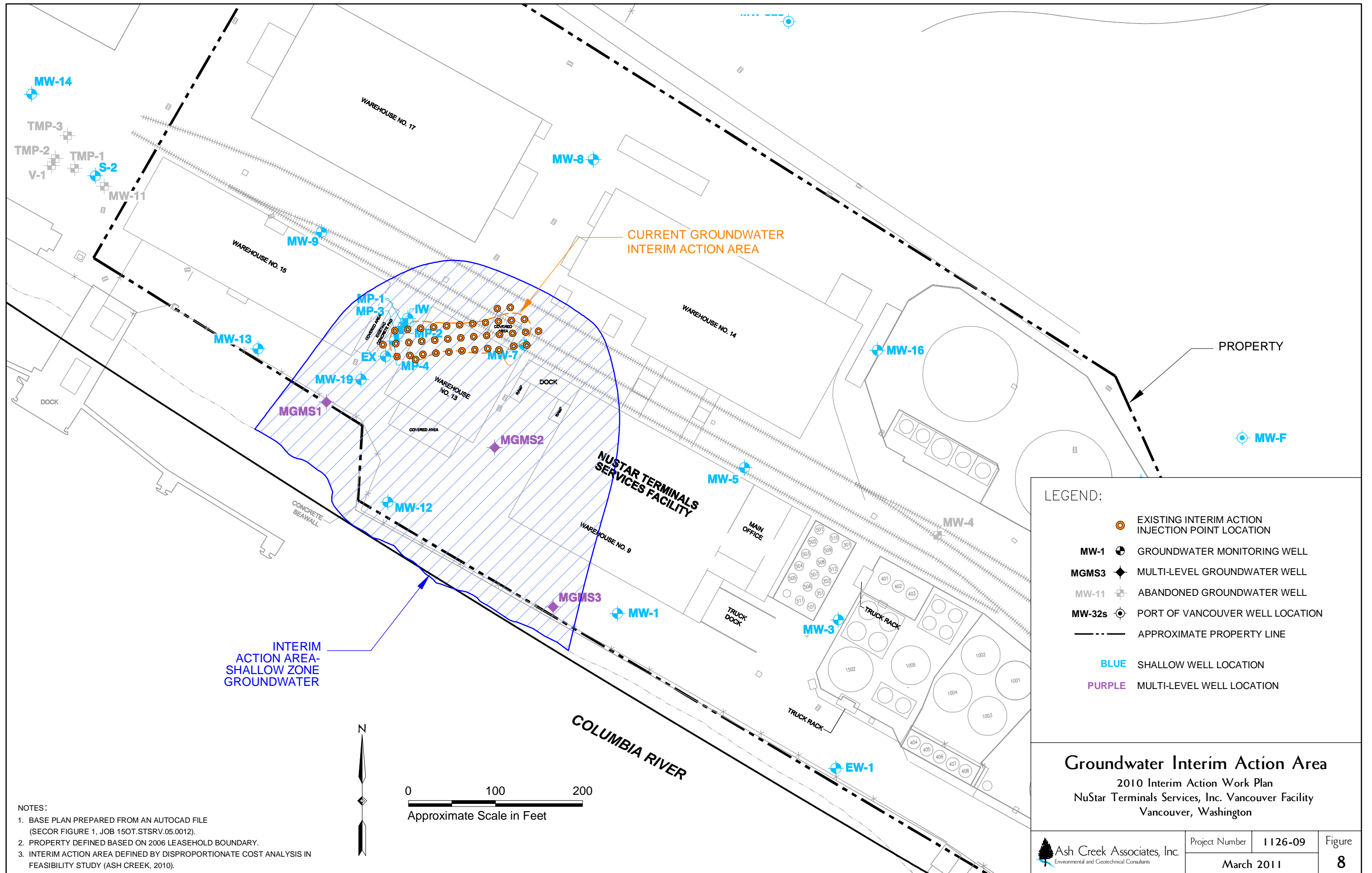

LEGEND:

- EXISTING INTERIM ACTION INJECTION POINT LOCATION
- MW-1** GROUNDWATER MONITORING WELL
- MGMS3** MULTI-LEVEL GROUNDWATER WELL
- MW-11** ABANDONED GROUNDWATER WELL
- MW-32s** PORT OF VANCOUVER WELL LOCATION
- APPROXIMATE PROPERTY LINE
- BLUE** SHALLOW WELL LOCATION
- PURPLE** MULTI-LEVEL WELL LOCATION

Groundwater Interim Action Area
 2010 Interim Action Work Plan
 NuStar Terminals Services, Inc. Vancouver Facility
 Vancouver, Washington

NOTES:

1. BASE PLAN PREPARED FROM AN AUTOCAD FILE (SECOR FIGURE 1, JOB 150T.STSRV.05.0012).
2. PROPERTY DEFINED BASED ON 2006 LEASEHOLD BOUNDARY.
3. INTERIM ACTION AREA DEFINED BY DISPROPORTIONATE COST ANALYSIS IN FEASIBILITY STUDY (ASH CREEK, 2010).

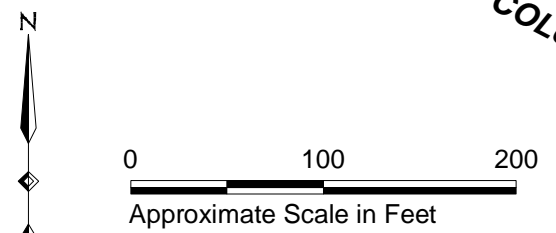



LEGEND:

- VE-1-2 ● 2008 INTERIM ACTION VAPOR EXTRACTION WELL LOCATION
- ⊗ VAPOR EXTRACTION WELL (2000-2005)
- EX-3 ⊕ EARLY 2000s INTERIM ACTION GROUNDWATER EXTRACTION WELL
- IN-1 ▽ EARLY 2000s INTERIM ACTION GROUNDWATER INJECTION WELL AND VAPOR EXTRACTION WELL
- MW-1 ⊕ GROUNDWATER MONITORING WELL
- MGMS3 ◆ MULTI-LEVEL GROUNDWATER WELL
- ☐ CATCH BASIN
- ▭ BUILDING
- x-x- FENCE
- e-e- ELECTRICAL
- se-se- SYSTEM ELECTRICAL
- ss-ss- STORM SEWER
- v-v- WATER
- MHO ○ MANHOLE
- ||||| RAILROAD TRACKS
- - - - - EXISTING UNDERGROUND SOIL VAPOR EXTRACTION (SVE) PIPING AND DIAMETER
- VE-1-2 ⊕ PROPOSED 2010 EXPANDED INTERIM ACTION WELL LOCATION AND VAULT
- - - - - NEW UNDERGROUND SVE PIPING AND DIAMETER
- NEW ABOVE-GROUND SVE PIPING AND DIAMETER

SVE System Layout

2010 Interim Action Work Plan Implementation
NuStar Terminals Services, Inc. Vancouver Facility
Vancouver, Washington

Project Number	1126-09	Figure	9
March 2011			

NOTES:

1. BASE PLAN PREPARED FROM AN AUTOCAD FILE (SECOR FIGURE 1, JOB 150T.STSRV.05.0012).
2. UTILITY LOCATIONS SHOWN BASED ON SURFACE MARKINGS BY UTILITY LOCATOR.

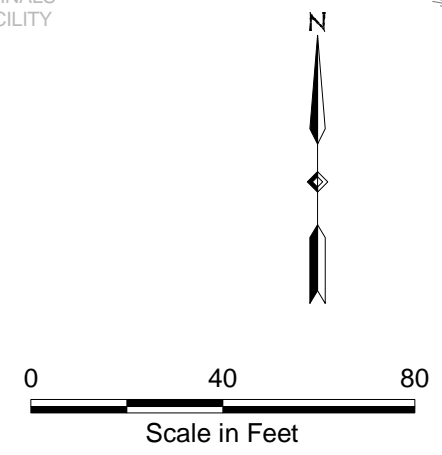

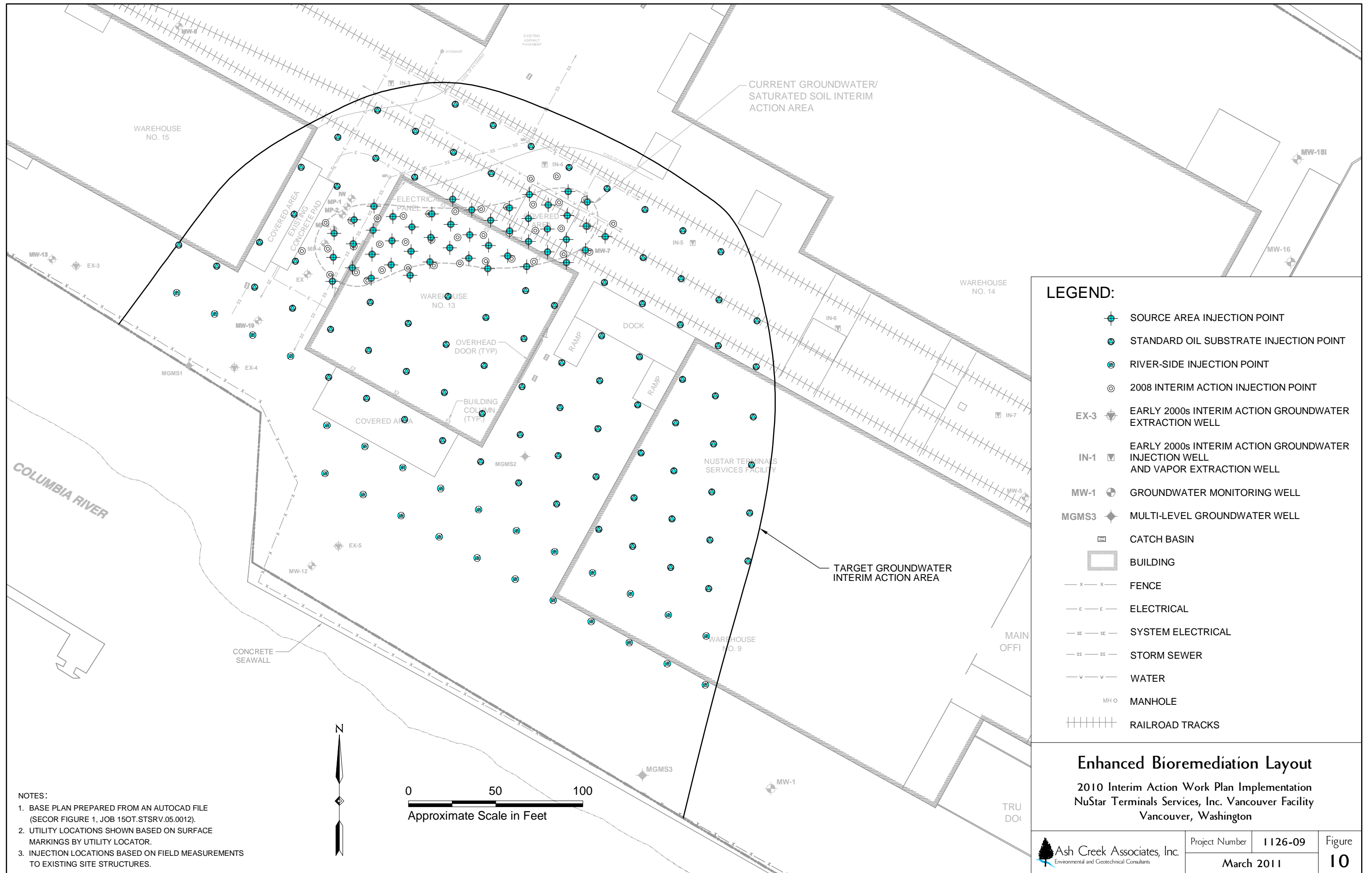

NOTES:
 1. BASE PLAN PREPARED FROM AN AUTOCAD FILE (SECOR FIGURE 1, JOB 150T.STSRV.05.0012).
 2. UTILITY LOCATIONS SHOWN BASED ON SURFACE MARKINGS BY UTILITY LOCATOR.
 3. INJECTION LOCATIONS BASED ON FIELD MEASUREMENTS TO EXISTING SITE STRUCTURES.

LEGEND:

- SOURCE AREA INJECTION POINT
- STANDARD OIL SUBSTRATE INJECTION POINT
- RIVER-SIDE INJECTION POINT
- 2008 INTERIM ACTION INJECTION POINT
- EX-3 EARLY 2000s INTERIM ACTION GROUNDWATER EXTRACTION WELL
- IN-1 EARLY 2000s INTERIM ACTION GROUNDWATER INJECTION WELL AND VAPOR EXTRACTION WELL
- MW-1 GROUNDWATER MONITORING WELL
- MGMS3 MULTI-LEVEL GROUNDWATER WELL
- CATCH BASIN
- BUILDING
- FENCE
- ELECTRICAL
- SYSTEM ELECTRICAL
- STORM SEWER
- WATER
- MANHOLE
- RAILROAD TRACKS

Enhanced Bioremediation Layout

2010 Interim Action Work Plan Implementation
 NuStar Terminals Services, Inc. Vancouver Facility
 Vancouver, Washington

Appendix A

Interim Action Performance Evaluation Report

Table of Contents

1.0 INTRODUCTION	1
1.1 Purpose	1
1.2 Report Organization	1
2.0 BACKGROUND	2
2.1 Site Description	2
2.2 Source Area Evaluation.....	2
2.3 Description of Current Interim Action.....	3
3.0 INTERIM ACTION PERFORMANCE MONITORING.....	3
3.1 SVE Evaluation.....	3
3.2 Confirmation Sampling	4
4.0 PERFORMANCE MONITORING RESULTS	6
4.1 SVE Evaluation Results.....	6
4.2 Soil Confirmation Sampling Results	7
4.3 Groundwater Results.....	7
5.0 INTERIM ACTION PERFORMANCE EVALUATION	7
5.1 Vadose Zone Soil	7
5.2 Groundwater and Saturated Soil	10
5.3 Conclusions and Recommendations	12
6.0 REFERENCES	13

Tables

1	SVE Monitoring Results
2	SVE Analytical Results
3	Soil Comparison Table - 2006 and 2010 Investigations
4	Groundwater Comparison Table - 2006 and 2010 Investigations
5	VOC Mass Removal Table
6	Summary of PID Measurements
7	Groundwater Analytical Results: Bioremediation Parameters



Figures

- 1 Property Location Map
- 2 Property Plan
- 3 Interim Action Area
- 4 SVE System Site Plan
- 5 SVE System Diagram
- 6 SVE Interim Action VOC Mass Removal
- 7 PID Comparison

Appendices

- A Field Methods and Sampling Procedures
- B Boring Logs
- C Current and Historical Analytical Data
- D Laboratory Data Quality Assurance Review and Laboratory Analytical Reports

1.0 Introduction

An Interim Action (IA) was implemented at the NuStar Terminal Services, Inc. (NuStar) bulk storage terminal at the Port of Vancouver Terminal No. 2, located at 2565 NW Harborside Drive in Vancouver, Washington (Property) in April 2008. The IA included soil vapor extraction (SVE) to address the vadose zone, and bioremediation injections to address saturated soil and groundwater. Ash Creek Associates Inc. (Ash Creek) conducted soil and groundwater sampling in the IA area in October 2010, to assess the progress of the actions. This Interim Action Performance Evaluation report presents the results of the recent sampling and an evaluation of IA monitoring data at the Property. A Property location map is provided as Figure 1. Work was performed pursuant to Agreed Order (AO) No. 07-TC-S DE3938 between Washington State Department of Ecology (Ecology) and NuStar.

Consistent with previous project reports, the term "Property" as used herein refers to the NuStar leasehold area as of 2006. The term "Site" is defined to include the area where a hazardous substance from a release at the Property has "come to be located."

1.1 Purpose

The work was completed to assess current soil and groundwater conditions in the primary source area (as defined in the Revised Remedial Investigation [RI]; Ash Creek, 2009) in order to evaluate the progress of the current IA. The data from this investigation are also intended to provide information to support design of an expanded IA at the Property.

1.2 Report Organization

This Interim Action Performance Evaluation Report includes the following main topics:

- Section 2 summarizes the background of the Property, including a site description, a summary of the previous source area investigation and a description of the current IA at the Site.
- Section 3 summarizes the scope of work of the IA performance evaluation.
- Section 4 summarizes the results.
- Section 5 presents an interpretation of the results and provides a summary of conclusions and associated recommendations.

Detailed field methods and sampling procedures are presented in Appendix A. Appendix B includes the boring logs for each of the direct-push explorations completed during the recent investigation. Summaries of current and historical analytical data are provided in Appendix C. The laboratory data quality assurance review and laboratory analytical reports are included in Appendix D.

2.0 Background

This section briefly discusses the site setting, previous source area investigations, and the current IA at the Property. Additional detail is provided in the *Revised Remedial Investigation* (Ash Creek, 2009) and the *Expanded Interim Action Work Plan* (Ash Creek, 2011).

2.1 Site Description

The Property is located at the Port of Vancouver Terminal No. 2 in Vancouver, Washington (as shown on Figure 1). The Property address is 2565 NW Harborside Drive, Port of Vancouver, Vancouver, Washington 98660 (Latitude: N45° 38.26', Longitude: W122° 42.20'). The Property is owned by the Port of Vancouver (Port) and leased by NuStar. Figure 2 is a Property Plan. The Property is roughly rectangular with nominal dimensions of 600 by 1,300 feet and a total area of approximately 17 acres. The Property is on the north shore of the Columbia River, located between river mile 104 and 105. Land to the north, east, and west is industrial land also owned by the Port. The Property is located on Clark County Tax Lot (TL) Nos. 151979-000, 502010-002, 502010-000, and a portion of 502020-000, as well as a portion of the Washington Department of Natural Resources tideland area managed by the Port.

The Property includes five buildings (Warehouses 9, 13, 14, 15, and 17), a loading dock, three aboveground storage tank (AST) farms, two tank truck loading/unloading racks, a rail tank car loading/unloading area, marine vessel dock and piping, and an office.

Although a variety of products have been handled at the Property over the years, the historical sampling and the RI identified chlorinated solvents as the chemicals of interest. Tetrachloroethene (PCE), trichloroethene (TCE), methylene chloride (MC), and 1,1,1-trichloroethane (TCA) were handled by several companies prior to 1976, but the start date is uncertain. The records suggest that handling of chlorinated solvents may have ended as early as 1990, but the end date is uncertain. Currently, products such as jet fuel, methanol, sodium hydroxide, and calcium chloride are received and transported via ship, pipeline, railcar, and trucks at the Property. Products are also blended, packaged, and stored on the Property.

2.2 Source Area Evaluation

The RI included a comprehensive site investigation on the Property to: (1) assess the results of previous interim cleanup actions at the Site; (2) collect sufficient data to determine whether further IA was needed, and if so, evaluate and select the appropriate action(s); and (3) provide additional data for a Feasibility Study (FS) for the final action for the Site. The investigation activities included the completion of 49 push-probe explorations across the Property. Soil and/or grab-groundwater samples were collected from these explorations for laboratory analysis. A total of 71 soil samples and 126 groundwater samples were submitted to the laboratory to analyze for the presence of halogenated volatile organic compounds

(HVOCs). Results of these investigations are provided in detail in the Site Investigation Data Summary Report (Ash Creek, 2006a) that was incorporated into the RI (Ash Creek, 2009a).

2.3 Description of Current Interim Action

An IA was implemented to address the release area at the Property while the RI and FS were being completed. The objective of the IA is to reduce threats to human health and the environment from chemicals within the source area. An analysis of IA alternatives was completed to select the appropriate action (Ash Creek, 2006b). Based on the results of the IA analysis, enhanced anaerobic bioremediation and SVE were selected for IA and described in detail in a design report (Ash Creek, 2007). Ecology approved the design report in a letter dated January 10, 2008. Ash Creek submitted a comment response letter to Ecology on May 7, 2008 (Ash Creek, 2008c) addressing comments and questions that Ecology had provided in the approval letter.

The IA was initiated in April 2008. The IA was focused in the area with relatively higher concentrations of volatile organic compounds (VOCs) that may be acting as an ongoing source to vapor and groundwater. The general scope of the IA consisted of installation of temporary injection points, injection of a bioremediation substrate, installation of SVE wells and associated trenching/pipe installation, and installation and startup of the SVE system. The enhanced bioremediation locations are shown on Figure 3 and the SVE system layout is shown on Figure 4. Pursuant to the AO, Ash Creek submitted the *Interim Action Installation Report* to Ecology on May 5, 2009 (Ash Creek, 2009). The extent of the vadose zone and groundwater IA cleanup areas are shown on Figure 5.

3.0 Interim Action Performance Monitoring

The following sections summarize the IA evaluation activities, including SVE monitoring and soil and groundwater confirmation sampling.

3.1 SVE Evaluation

The SVE system was started on September 17, 2008. Startup monitoring of the system was conducted on September 18, 2008. Routine monitoring of the SVE system has been conducted on a monthly basis since startup.

3.1.1 SVE Monitoring

The monthly monitoring consists of effluent vapor sampling before and after carbon treatment, and photoionization detector (PID) monitoring at each of the influent branches. The PID measurements collected each month are listed in Table 1. Vapor measurements made with the PID are used to assess the

relative distribution of VOCs present in the five influent branches and the system effluent (pre-, mid-, and post-carbon treatment; Figure 6).

3.1.2 Analytical Results

During the monthly SVE monitoring events, vapor samples are collected into Summa™ canisters, both pre-carbon (influent) and post-carbon (effluent), and are submitted to TestAmerica Laboratories in Los Angeles, California, for analysis of VOCs by method TO-15. Table 2 presents the analytical results of the system effluent sampling. Effluent sampling laboratory analytical reports were previously provided in the *Interim Action Installation Report* (Ash Creek, 2009) and in subsequent semi-annual groundwater monitoring reports. The laboratory analytical reports that were received after the last reporting period (first semi-annual period 2010) are provided in Appendix D.

3.2 Confirmation Sampling

Soil and groundwater sampling were conducted in the primary source area to evaluate the progress of the IA. The soil and groundwater sampling results are also being used to design an expanded IA at the Property.

3.2.1 Sample Locations

Sampling was focused within the IA zone of influence, particularly in those areas where soil and groundwater concentrations were the most elevated during the pre-IA (2006) site investigation. Borings CB-1, CB-2 and CB-4 were located within close proximity to historical borings AGP-28, AGP-29 and AGP-22, respectively, as shown on Figure 3. Soil and groundwater samples were collected from these borings at similar depths to soil and groundwater samples collected during the 2006 site investigation. The location of CB-3 was selected to evaluate the “center” of the soil and groundwater IA areas and was not located in a previously investigated area. In addition to the confirmation sampling, soil samples were collected at additional depths where elevated PID readings were identified during field screening. The depths of the 2006 and 2010 soil and groundwater samples are summarized in Tables 3 and 4, respectively.

3.2.2 Drilling, Sampling, and Field Screening

The field methods and sampling procedures for the completed field work are presented in Appendix A and summarized herein. On September 20 and 21, 2010, four borings (CB-1 through CB-4) were completed using a direct-push rig to a depth of 50 feet below ground surface (bgs). Continuous soil cores were extracted and soil conditions were logged in general accordance with ASTM 2487/2488. The continuous cores were retrieved using a 5-foot soil sampler. Each soil core was field screened for VOCs using a PID at nominal 2.5-foot intervals (half of each soil core). Boring logs are presented in Appendix B, and include a

description of the encountered lithology, field screening results for each sample interval, and sample information. Soil samples were collected in accordance with EPA Method 5035.

3.2.3 Selection of Samples for Chemical Analysis

The following sections summarize the selection of samples for chemical analysis and a summary of analytical parameters by media.

3.2.3.1 Soil

Soil samples were selected for chemical analyses in accordance with the following criteria:

- Soil samples that were collected at the approximate location and depth of samples from the 2006 event were submitted for laboratory analysis.
- Samples with elevated PID readings during field screening that were not assessed according to the bullet above, were also submitted for laboratory analysis.

The selected soil samples were submitted to the analytical laboratory for analysis of VOCs by EPA Method 8260.

3.2.3.2 Groundwater

During the 2006 groundwater investigation event, groundwater samples were collected from borings AGP-22, AGP-28 and AGP-29 at depths of 25, 35 and 45 feet bgs. Samples were collected in temporary wells with 4-foot screened intervals, with the bottom of the screen being set at the referenced well depth (25 feet, 35 feet, etc.). As discussed in Section 3.2.1, groundwater samples were collected at the same locations and depths during the 2010 groundwater investigation. During the 2010 site investigation, the depth to groundwater was approximately 30 feet bgs, so it was not possible to collect groundwater samples at 25 feet bgs. Groundwater samples were collected in borings CB-1 through CB-4 at 35 feet bgs and 45 feet bgs. The well screens in these boreholes were consistent with the 2006 event.

A total of eight groundwater samples collected from four soil borings were submitted to the analytical laboratory for VOC analysis by EPA Method 8260B.

Additionally, groundwater samples were collected from monitoring wells MW-9, MGMS2-40, and soil boring CB-3 (at 45 feet bgs) to evaluate conditions for bioremediation. Monitoring wells MW-9 and MGMS2-40 were selected to evaluate groundwater conditions both upgradient and downgradient from the source area, respectively, and outside of the (understood) area of influence of the current groundwater IA (see Figure 3). Boring CB-3 was selected to evaluate indicators of bioremediation within the IA area. Groundwater samples collected from MW-9, MGMS2-40, and CB-3 were submitted to the laboratory for the following analyses:

Analysis	Analytical Method
Total Organic Carbon	415.2/5310C
Potassium, Iron and Manganese	EPA 6010B
Ammonia	EPA 350.1
Chloride, Nitrate, Nitrite, Sulfate	EPA 300.0
Methane, Ethane, Ethene	RSK 175
Orthophosphate	SM 4500P
HVOCs	8260

Additionally, groundwater samples were collected in monitoring wells MW-12, MW-19 and MGMS1-40 for analysis of Nitrates by EPA Method 300.0. Groundwater samples from boring CB-3, located within the IA cleanup area, were also analyzed for the following bioremediation parameters:

Analysis	Analytical Method
Metabolic Acids	WCAS SOP 4130
Carbon Dioxide	SM 4500-CO2 D

As part of the third quarter 2010 groundwater monitoring event conducted concurrently with the 2010 site investigation, monitoring wells MW-7, EX, and MP-1 were sampled for parameters used to evaluate the anaerobic degradation of chlorinated solvents. The groundwater samples were analyzed for the following analyses:

Analysis	Analytical Method
HVOCs	8260
Total Organic Carbon	415.2/5310C
Methane, Ethane, Ethene	RSK 175

4.0 Performance Monitoring Results

A summary of SVE monitoring and confirmation soil and groundwater monitoring results are provided in the sections below.

4.1 SVE Evaluation Results

The system has removed approximately 1,860 pounds of VOCs since startup in September 2008, as shown on Figure 5 and in Table 5. Based on the pre-carbon effluent sampling results (Table 2), over 99 percent of VOCs removed by the system were chlorinated ethene compounds. The mass removal rate at startup was 59 pounds per day (lbs/day), and within three months the mass removal rate had fallen to 2.4 lbs/day.

Since then, the mass removal rate has been relatively steady with most values between 0.8 and 2.1 lbs/day and the average at 1.8 lbs/day. In the most recent sample (August 2010), the mass removal rate was 1.8 lbs/day.

4.2 Soil Confirmation Sampling Results

The following sections summarize the field screening and laboratory analytical results associated with the soil sampling event.

4.2.1 PID Results

PID measurements for each exploration are presented on boring logs in Appendix B and in Table 6. PID measurements greater than 5.0 parts per million (ppm) were observed in each of the explorations and typically correlated with the reported concentrations in the associated soil and groundwater samples, as shown in Tables 3 and 4.

4.2.2 Laboratory Analytical Results

Using the criteria listed in Section 3.2.3.1, 14 soil samples were submitted to the analytical laboratory for analysis. Eleven of these samples were collected from the vadose zone (depths of less than 30 feet bgs) and three samples were collected from the saturated soil (depths between 30 and 45 feet bgs). Soil analytical results are summarized in Appendix C and in Table 3. The laboratory analytical reports and a data quality assurance review are included in Appendix D.

4.3 Groundwater Results

A total of eight groundwater samples were collected and submitted to the analytical laboratory for analysis. Groundwater analytical data tables are included in Appendix C and in Tables 4 and 7. Detected VOCs included chloroethenes (PCE, TCE, 1,1-DCE, cis-1,2-DCE, trans-1,2-DCE, and vinyl chloride [VC]) and chloroethanes (1,1,1-TCA, 1,1-DCA and 1,2-dichloroethane [1,2-DCA]). The laboratory analytical reports and a data quality assurance review are included in Appendix D.

5.0 Interim Action Performance Evaluation

5.1 Vadose Zone Soil

Vadose zone soil is being treated with SVE. The overall performance of the SVE system was evaluated using multiple lines of evidence as follows:

- PID monitoring of vadose zone soil samples;



-
- Concentration changes in vadose zone soil samples; and
 - Mass removal by the SVE system.

PID Monitoring of Vadose Zone Soil Samples. PID measurements from before and after the IA provide a qualitative evaluation of the performance of the SVE system in removing VOCs from the vadose zone soil. Table 6 lists the PID measurements for the pre- and post-IA soil samples. In the pre-IA borings, 26 of 35 samples (74 percent) had measureable PID readings. In the post-IA borings, 11 of 44 samples (25 percent) had measureable PID readings. A comparison of boring log pairs from before and after implementation of the IA is provided on Figure 7. The logs include soil type information and PID measurements, and indicate that the majority of the 2010 VOC detections occur only in silty soils or soils with a silty component. These data semi-quantitatively indicate a substantial reduction in VOCs in soil within the vadose zone.

VOC Concentrations in Vadose Zone Soil Samples. Evaluation of VOC concentration reductions is difficult because there is extreme variability in soil concentrations over very short distances. This can be further complicated if non-aqueous phase liquid (NAPL) is present. To assess the potential presence of NAPL, the saturation limit was estimated from the three-phase partitioning equation (Model Toxics Control Act Equation 747-1). Concentrations above the saturation limit are suggestive of the presence of NAPL. The saturation limit concentration of PCE is approximately 200,000 micrograms per kilogram ($\mu\text{g}/\text{kg}$), so concentrations above that are indicative of potential NAPL. The results suggest that NAPL may be present in soil within the source area, especially within silt layers or silty zones.

Whether or not NAPL is present, pockets of relatively elevated VOC concentrations were identified in silts or silty zones within the vadose zone in the source area. Soil samples collected from the same soil core will have greatly different concentrations if one sample has a NAPL drop and the other does not, or if one sample has elevated concentrations of VOCs trapped in silt and the other does not. The presence of NAPL, or areas of higher concentrations of VOCs, presents a further complication when evaluating the progress of SVE. As the SVE system removes vapors surrounding areas of higher concentrations of VOCs (or NAPL), the mass of VOCs remaining decreases, but the concentration in soil will remain relatively high. This can even result in an apparent increase in concentration after treatment if the after-treatment sample has a NAPL droplet but the before-treatment sample does not. Therefore, to assess the general performance of the SVE system using soil concentrations, only soil data from the vadose zone that is not indicative of NAPL were evaluated

Excluding sample pairs where at least one sample was indicative of NAPL, the following lists the before and after concentration data from vadose zone soil (from Table 3) together with an evaluation of concentration reduction.

Sample Pair	Date	PCE in µg/kg	TCE in µg/kg
AGP-22-18/ CB-4 (18)	2006	41,700	2,180
	2010	2,000	<5
AGP-28-17.5/CB-1(17.5)	2006	65,200	1,870
	2010	10,000	93
AGP-29-18/CB-2 (18)	2006	14,900	<93
	2010	19	<5
AGP-29-28/CB-2 (28)	2006	821	<102
	2010	15	<5
2006 Average		30,600	2,020
2010 Average		3,010	48
Percent Reduction		90 percent	98 percent

PCE and TCE are summarized here as they represent over 99 percent of the VOC mass at the Site. These results suggest that, except for areas of higher concentrations of VOCs associated with silt layers, the SVE system has reduced soil VOC concentrations 90 percent or more during the two years of operation.

SVE System Mass Removal. As discussed in Section 4.1, approximately 1,900 pounds of VOCs have been removed by the SVE system. Initially, the system exhibited behavior consistent with most SVE systems where high mass removal rates at startup rapidly decrease. However, unlike most systems where the mass removal rate continues to decline toward an asymptotically low value, the mass removal rate since shortly after startup has been essentially constant. This result is consistent with the prior results for PID monitoring and soil concentrations. The PID monitoring indicates that remaining VOCs in the treatment area are associated with silt layers. A review of the 2010 performance evaluation boring logs provided on Figure 7 indicates that approximately 78 percent of the vadose zone in the source area consists of sands and approximately 22 percent consists of silts. With an approximate 90-percent reduction in PCE and 98-percent reduction in TCE observed in sandy soils between the 2006 and 2010 site assessments, this would suggest that at least 70 percent of the PCE mass and 74 percent of the TCE mass has been removed from the vadose zone to date. Mass removal is also occurring in silts, yet at a lower rate than in sands, so it is anticipated that the percent VOC mass removed from the Site is even higher than 70 to 74 percent.

Because of the higher concentrations in silt zones, the rate of volatilization from areas of elevated concentrations, and the rate of diffusion into larger soil voids, will move towards an equilibrium state with the mass removal by the SVE system. Until the higher concentrations in the silt are exhausted, they will continue to contribute mass at a roughly constant rate. As discussed in the paragraph above, there is a limited amount of silty soil present in the vadose zone in which VOCs are concentrated. The SVE system has removed mass from the coarser-grained soils in the vadose zone and continues to remove mass from

the fine-grained soils. An observed continuing decrease in the mass removal rate will be the indicator that these sources are exhausted and the source area vadose zone soils are approaching cleanup.

Summary of SVE System Performance. Based on the above discussion, the SVE system is effectively removing VOCs from the vadose zone soil, summarized as follows:

- Except for higher concentrations of VOCs located within silt layers, the SVE system has removed at least 90 percent of the VOCs present in the vadose zone.
- The system is removing VOCs from remaining higher concentration pockets at an approximately constant rate of 2 lbs/day (equivalent of over 50 gallons per year).

5.2 Groundwater and Saturated Soil

5.2.1 VOCs in Groundwater

The average concentrations of VOCs in the groundwater IA area were compared between the 2006 and 2010 groundwater sampling events (Table 4). The average mass-based concentration ($\mu\text{g/L}$) of PCE decreased by 85 percent between the 2006 and 2010 groundwater investigations. The concentrations of successive degradation products of PCE (sequentially TCE, cis-1,2-dichloroethene [cDCE], and VC) also decreased, but to a lesser extent than PCE (79 percent, 45 percent, and 48 percent, respectively). Concentrations of degradation products of PCE measured during individual monitoring events can vary as these concentrations reflect the net conditions of generation of these products from breakdown of the parent compound less the destruction of the compounds into subsequent products. It is also not unusual to observe temporary increases in the concentrations of degradation products. Overall, the best indicator of effective reduction of chlorinated ethenes is a decrease in the total molar concentration of PCE, TCE, total DCE (cis-1,2 DCE, trans-1,2 DCE and 1,1-DCE) and VC combined. The average total molar ethenes in the IA area decreased by 77 percent between the 2006 and 2010 groundwater investigations.

The reduction in total VOCs was relatively steady for the two-year period from May 2008 through April 2010. Monitoring well MW-7, located on the eastern edge of the groundwater IA area, has averaged approximately 35 percent reduction per quarter in molar ethenes during that period. Only one quarter during that period exhibited an increase in total concentration (September 2009). A similar increase was observed in September 2010. The data suggest that the oil is reaching the end of its effective life.

5.2.2 VOCs in Saturated Soils

Three of the 2006/2010 soil sample pairs were collected in saturated soils or in seasonally saturated soils. In each of these samples pairs, VOC concentrations in saturated soil either stayed the same or increased between 2006 and 2010. As discussed in Section 5.1, elevated concentrations of VOCs still remain in the

subsurface, particularly in silty soils. If material is adsorbed to silts located in saturated soils, then this could potentially contribute ongoing VOC concentrations to groundwater, so further IA is warranted.

5.2.3 Bioremediation Parameters

Groundwater samples from five monitoring wells and one boring (MP-1, MW-7, MW-9, MGMS2-40, EX, and CB-3) were collected for analysis of bioremediation parameters. The samples were analyzed for iron, manganese, potassium, nitrogen compounds (nitrate, nitrite, and ammonia), sulfate, total organic carbon, orthophosphate, chloride, dissolved gases (methane, ethane, ethene, and carbon dioxide), and volatile fatty acids (acetic, butyric, lactic, and propionic acids). These analytes, in conjunction with the VOC analysis and field measurements of dissolved oxygen and oxidation-reduction potential, were used to evaluate the condition of the groundwater environment with regards to sustaining the intended bioremediation process.

There is evidence from this sampling that the reductive dechlorination of chlorinated VOCs is continuing. This evidence includes the following:

- Observed decreases in chloroethene concentrations;
- Elevated concentrations of chloride in and down-gradient of the treatment area (chloride is a by-product of the dechlorination); and
- Elevated concentrations of methane and carbon dioxide within the treatment area.

However, the low concentrations of total organic carbon and volatile fatty acids (which were all non-detect) suggest that the initial bioremediation substrate injection (completed in May 2008) has nearly been fully utilized. The lack of these markers of substrate concentration is consistent with the concentrations of nitrate found in groundwater. The original injections were designed based on nitrate sample results from prior to May 2007, with concentrations ranging from 60 milligrams per liter (mg/L) to 240 mg/L (an average of 140 mg/L in the sampled wells). Since then, concentrations of nitrate within the area of interest have ranged from 43 mg/L to 990 mg/L (an average of 320 mg/L in the most recent sampling of vicinity wells). Although nitrogen compounds are necessary for cellular growth, excessive concentrations can interfere with the degradation of the target compounds and result in faster breakdown of the bioremediation substrate.

Based on these observations, a higher concentration of substrate material may be required for subsequent injections. The specific product used and the volume needed for such a subsequent injection will need to account for the high nitrate concentrations.

Summary of Bioremediation Performance. Based on the above discussion, the bioremediation substrate injections are effectively removing VOCs from the groundwater, summarized as follows:

- The bioremediation injections have resulted in a 77 percent decrease in total molar ethene concentrations within the treatment area since prior to the interim action.

-
- The bioremediation parameter data suggest that the current bioremediation substrate may be reaching the end of its effective life.
 - The effectiveness of the bioremediation was reduced by the presence of nitrate in the groundwater.

5.3 Conclusions and Recommendations

Based on this performance evaluation, the following conclusions and recommendations have been made regarding the current IA and anticipated expanded IA at the Site.

5.3.1 Soil

- The SVE system is effectively removing VOC mass from the vadose zone soils. SVE should be effective within the expanded IA area.
- Elevated concentrations of VOCs are present in isolated areas in silty soil. While the total mass remaining in the silty soil is not known, it is estimated that at least 70 to 74 percent of VOC mass—primarily comprised of chlorinated ethenes--has been removed from the vadose zone to date. The continued operation of the SVE system will help to reduce areas of elevated VOC concentrations; however, this will involve operating the SVE system for longer than anticipated at design.
- The expanded SVE area (i.e., the 2011 IA) is not within the former product handling area, so NAPL is not anticipated to be present in vadose zone soils in the expanded IA area. Therefore, it is expected that SVE operations in this area will exhibit classic behavior with concentrations that steadily decline to an asymptotically low value within a few years of operation. The duration of required SVE in this area should be less than the current IA.

5.3.2 Groundwater

- The 2008 bioremediation injections have effectively decreased VOC concentrations in groundwater. The presence of VOCs in saturated soil may continue to contribute VOCs to groundwater in the absence of further IA. Therefore, as part of the 2011 Interim Action, additional enhanced bioremediation should be conducted in the source area where treatment was initiated in 2008.
- Elevated nitrates in the IA area are interfering with the reductive dechlorination of chlorinated solvents and have likely accelerated the consumption of the bioinjection substrate. Design calculations of oil injection volumes accounted for the higher nitrate levels.



6.0 References

- Ash Creek Associates, 2006a. *Site Investigation Data Summary Report*, ST Services, Vancouver, Washington. October 18, 2006.
- Ash Creek Associates, 2006b. *Interim Action Analysis Report*, ST Services, Vancouver, Washington. November 28, 2006.
- Ash Creek Associates, 2007. *Release Area Interim Action Design*, ST Services, Vancouver, Washington. May 28, 2007.
- Ash Creek Associates, 2008. *Response to Comments on Release Area Interim Action Design*, NuStar Terminals Services, Inc. (NuStar) Vancouver Facility, Vancouver, Washington. May 7, 2008.
- Ash Creek Associates, 2009a. *Revised Remedial Investigation Report, NuStar Terminals Services, Inc., Vancouver Main Terminal, Vancouver, Washington*. October 1, 2009.
- Ash Creek Associates, 2009b. *Interim Action Installation Report, NuStar Terminals Services, Inc. Vancouver, Washington*. May 5, 2009.
- Ash Creek, 2010a. *Feasibility Study, NuStar Terminals Services, Inc., Vancouver Main Terminal, Vancouver, Washington (DRAFT)*. January 14, 2010.
- Ash Creek, 2011. *Expanded Interim Action Work Plan, NuStar Terminals Services, Inc., Vancouver Main Terminal, Vancouver, Washington*. March 3, 2011.



Table 1
SVE Monitoring Results
NuStar Vancouver Facility
Vancouver, Washington

Date	Branch 1		Branch 2		Branch 3		Branch 4		Branch 5		Pre Carbon		Post Carbon 1		Post Carbon 2	
	PID	Pressure	PID	Pressure	PID	Pressure	PID	Pressure	PID	Pressure	PID	Pressure	PID	Pressure	PID	Pressure
9/18/2008	339	-14.0	932	-13.0	801	-13.0	432	-14.0	445	-15.0	623	NM	0.0	NM	0.0	NM
10/15/2008	81	-19.0	445	-14.0	383	-14.0	103	-18.0	112	-19.0	184.8	-33.0	186.9	NM	81.7	NM
10/24/2008	--	--	--	--	--	--	--	--	--	--	--	--	--	--	--	--
11/5/2008	4.1	-15.0	13.7	-14.0	33.1	-14.0	9.7	-16.0	19.7	-16.0	49.1	-27.0	0.3	17.0	0.0	6.0
11/20/2008	NA	-17.0	NA	-17.0	NA	-17.0	NA	-17.0	NA	-18.0	38.8	-30.0	1.5	16.0	2.2	NM
12/18/2008	1.4	-17.0	1.7	-17.0	1.8	-17.0	0.9	-18.0	3.2	-19.0	32.8	-27.0	6.0	16.0	0.0	6.0
1/2/2009	--	--	--	--	--	--	--	--	--	--	--	--	--	--	--	--
1/23/2009	12.8	-11.0	24.2	-11.0	28.7	-11.0	10.9	-11.0	9.0	-11.0	22.6	-20	29.4	19.0	0.0	7.0
1/27/2009	NM	-16.0	NM	-16.0	NM	-16.0	--	--	--	--	NM	-26	NM	NM	NM	NM
2/5/2009	NM	-17.0	NM	-17.0	NM	-17.0	--	--	--	--	NM	-25	33.2	NM	0.0	NM
2/20/2009	11.9	-16.0	15.2	-16.0	19.1	-16.0	--	--	--	--	17.5	-26	34.6	17.0	0.0	7.5
3/27/2009	3.5	-18.0	8.3	-18.0	4.9	-18.0	--	--	--	--	18.9	-28	22.6	18.5	6.2	7.2
4/3/2009	--	--	--	--	--	--	--	--	--	--	--	--	--	--	--	--
4/27/2009	9.0	-18.0	16.8	-18.0	15.9	-18.0	16.9	-19.0	15.4	-20.0	25.4	-24	0.2	16	0.2	7.0
4/27/2009	--	--	--	--	--	--	--	--	--	--	--	--	--	--	--	--
5/27/2009	--	--	5.7	-18.5	5.0	-18.0	5.0	-18.0	--	--	16.3	-29.5	0.4	26	0.2	7.0
6/26/2009	--	--	6.6	-18.5	9.2	-18.0	1.0	-18.5	--	--	22.3	-30	10.8	15.5	0.0	6.5
7/31/2009	--	--	32.2	-17.0	27.8	-17.0	27.3	-18.0	--	--	20.5	-29	16.4	16.5	0.0	7.0
8/28/2009	--	--	35.6	-16.0	35.2	-16.0	32.0	-16.0	--	--	19.1	-28	13.8	16.0	1.1	7.1
9/3/2009	--	--	--	--	--	--	--	--	--	--	--	--	--	--	--	--
09/09/09	--	--	--	--	--	--	--	--	--	--	--	--	--	--	--	--
9/29/2009	25.5	-13.5	51.6	-12.5	61.3	-12.0	--	--	--	--	148.0	-24.5	12.5	18.0	0.0	7.0
10/27/2009	16.6	-14.0	39.9	-14.0	30.3	-13.5	--	--	--	--	17.7	-25	9.1	18.0	0.0	7.8
10/27/09	--	--	--	--	--	--	--	--	--	--	--	--	--	--	--	--
11/30/2009	--	--	95.4	-21.0	85.7	-22.0	59.6	-21.0	--	--	66.1	-33	5.6	17.0	0.0	6.0
12/30/2009	--	--	88.5	-17.0	91.7	-18.0	86.5	-18.0	--	--	50.8	-28.5	4.3	17.0	0.2	7.4
1/12/2010	--	--	--	--	--	--	--	--	--	--	--	--	--	--	--	--
1/22/2010	--	--	--	--	--	--	--	--	--	--	--	--	--	--	--	--
1/27/2010	--	--	45.6	-22.0	49.2	-22.0	39.9	-23.0	--	--	29.0	-31.0	0.0	16.5	0.0	6.9
2/12/2010	--	--	--	--	--	--	--	--	--	--	--	--	--	--	--	--
2/25/2010	--	--	0.0	-21.0	0.1	-22.0	0.8	-22.0	--	--	37.8	-30.0	0.5	16.0	0.0	10
3/25/2010	--	--	21.0	-22.0	24.9	-21.0	24.2	-20.0	--	--	16.9	-32.0	0.0	14.0	0.0	6.4
4/29/2010	--	--	23.0	-22.0	19.1	-22.0	20.3	-22.5	--	--	15.2	-32.0	4.5	14.5	0.0	6.7
5/25/2010	--	--	11.8	-22.0	27.8	-22.0	23.6	-23.0	--	--	28.9	-32.0	19.3	15.0	0.0	6.5
6/29/2010	--	--	22.0	-21.0	22.3	-22.0	20.6	-22.0	--	--	15.0	-32.0	29.3	15.0	0.2	7.0
7/29/2010	--	--	26.6	-21.0	24.6	-21.0	14.9	-22.0	--	--	16.0	-33.0	13.2	15.0	1.0	6.4
8/25/2010	--	--	20.6	-18.0	23.6	-18.0	19.4	-19.0	--	--	15.8	-29.0	0.0	16.0	0.0	16.0

Notes:

1. PID readings in parts per million (ppm), calibrated to 100 ppm isobutylene.
2. Pressure readings in inches of water, measured with magnahelic gauge.
3. NM = Not measured.
4. -- = Not available; branch not in use or no measurement collected during the site visit.
5. NA = Not available; photoionization detector (PID) malfunction.

Table 2
Soil Vapor System Analytical Results
NuStar Terminals Services, Inc.
Vancouver, Washington

Sampling Location	Sample ID	Date	Chloroform	1,3-Dichlorobenzene	1,1-Dichloroethane	1,1-Dichloroethene	cis-1,2-Dichloroethene	trans-1,2-Dichloroethene	Methanol	Methylene Chloride	Tetrachloroethene	Toluene	1,1,1-Trichloroethane	Trichloroethene	1,1,2-Trichloro-1,2,2-trifluoroethane	Total Xylenes
			Concentrations in µg/m ³													
Effluent - pre-Carbon	SVE_091808	9/18/2008	<5,400	<2,600	<4,500	<4,400	<4,400	<4,400	--	<3,800	1,700,000	<4,100	14,000	55,000	<8,400	<4,800
Effluent - pre-Carbon	System_In_101508 Canister 9301B	10/15/2008	<1,600	<3,800	<1,300	<1,300	<1,300	<1,300	--	<1,100	150,000	<1,200	<1,700	7,700	<2,500	<1,400
Effluent - post-Carbon	System_Out_101508 Canister 12204	10/15/2008	<410	<1,000	<340	<340	<340	<340	--	<290	60,000	<320	<460	3,200	<650	<370
Carbon change-out 10/24/08																
Effluent - pre-Carbon	063299 - Pre Carbon 112008	11/20/2008	<810	<2,000	<670	<660	<660	<660	--	<570	85,000	<620	<900	4,100	<1,300	<720
Effluent - post-Carbon	12541 - Post Carbon 112008	11/20/2008	<9.8	<24	<8.1	<7.9	<7.9	<7.9	--	17	23	<7.5	<11	<11	<15	<8.7
Effluent - pre-Carbon	Pre Carbon 121808	12/18/2008	<360	<900	<300	<300	<300	<300	--	<260	69,000	<280	<530	3,400	<570	<320
Effluent - post-Carbon	Post Carbon 121808	12/18/2008	<9.8	<24	<8.1	<7.9	<7.9	<7.9	--	12	<14	<7.5	<16	<11	<15	<8.7
Effluent - pre-Carbon	SVE Effluent Pre-Carbon	1/23/2009	<400	<980	<330	<320	<320	<320	--	<280	68,000	<310	<450	1,800	<630	<350
Effluent - post-Carbon	SVE Effluent Post-Carbon	1/23/2009	<9.8	<24	<8.1	<7.9	<7.9	<7.9	--	12	<14	<7.5	<11	<11	<15	<8.7
Effluent - pre-Carbon	Pre Carbon 022009	2/20/2009	<270	<680	<230	<220	<220	<220	--	<200	53,000	<210	<310	2,100	<430	<240
Effluent - post-Carbon	Post Carbon 022009	2/20/2009	<9.8	<24	<8.1	<7.9	<7.9	<7.9	--	15	<14	<7.5	<11	<11	<15	<8.7
Effluent - pre-Carbon	Pre Carbon 032709	3/27/2009	<9.8	<24	<8.1	16	190	<7.9	--	8.7	67,000	<7.5	490	2,500	<15	<8.7
Effluent - post-Carbon	Post Carbon 032709	3/27/2009	12	<24	38	44	1,100	28	--	8.9	54	<7.5	7,200	19,000	34	<8.7
System shutdown on 3/27/09 in anticipation of carbon change-out on 4/3/09																
Effluent - pre-Carbon	Pre Carbon 042709	4/27/2009	<390	<950	<320	<310	<310	<310	--	<280	79,000	<300	<430	1,900	<610	<340
Effluent - post-Carbon	Post Carbon 042709	4/27/2009	<9.8	<24	<8.1	<7.9	<7.9	<7.9	--	<7.0	<14	<7.5	<11	<11	<15	<8.7
Effluent - pre-Carbon	PSE0888-01 - Pre Carbon 052709	5/27/2009	<280	<690	<230	<230	<230	<230	--	<200	49,000	<220	380	1,700	<440	<250
Effluent - post-Carbon	PSE0888-02 - Post Carbon 052709	5/27/2009	<9.8	<24	<8.1	<7.9	<7.9	<7.9	--	9.7	<14	<7.5	<11	<11	<15	<8.7
Effluent - pre-Carbon	PRE Carbon 062609	6/26/2009	<240	<600	<200	<200	<200	<200	--	<170	55,000	<190	390	2,000	<380	<220
Effluent - post-Carbon	POST Carbon 062609	6/26/2009	<9.8	<24	<8.1	<7.9	<7.9	<7.9	--	8.2	<14	<7.5	<11	<11	<15	<8.7
Effluent - pre-Carbon	PRECARBON 073109	7/31/2009	<46	<110	<38	<37	280	<37	--	38	47,000	<36	540	2,800	<72	<41
Effluent - post-Carbon	POSTCARBON 073109	7/31/2009	<9.8	<23	<8.1	20	<7.9	<7.9	--	12	<14	<7.5	<11	<11	<15	<8.7
Effluent - pre-Carbon	Precarbon 082809	8/28/2009	<98	<240	<81	<79	<79	<79	--	<69	33,000	<75	300	2,100	<150	<87
Effluent - post-Carbon	Post Carbon 082809	8/28/2009	<26	<65	33	38	1,100	<21	--	<19	<36	28	1,500	260	<41	55
Effluent - pre-Carbon	PRECARBON 090209	9/2/2009	<240	<600	<200	<200	250	<200	<330	<170	37,000	<190	320	2,000	<380	<260
Lead carbon change-out September 8, 2009. Order of lead and lag carbon switched.																
Effluent - pre-Carbon	Precarbon 092909	9/29/2009	<220	<530	<180	<180	400	<180	<730	<150	49,000	<170	250	2,300	<340	<190
Effluent - post-Carbon	Post Carbon 092909	9/29/2009	<9.8	<24	<8.1	<7.9	<7.9	<7.9	40	81	<14	8.4	<11	<11	<15	<8.7
Effluent - pre-Carbon	PRECARBON 102709	10/27/2009	<98	<240	<81	<79	240	<79	<13	<69	48,000	<75	280	1,900	<150	<87
Effluent - post-Carbon	POSTCARBON 102709	10/27/2009	<9.8	<24	<8.1	<7.9	14	<7.9	<1.3	8.8	<14	<7.5	<11	<11	<15	<8.7
Effluent - pre-Carbon	Precarbon 113009	11/30/2009	<1,300	<3,200	<1,100	<1,100	<1,100	<1,100	<170	<920	170,000	4,100	<1,400	4,000	<2,000	<1,200
Effluent - post-Carbon	Postcarbon 113009	11/30/2009	<9.8	<24	<8.1	17	110	<7.9	<1.3	7.9	<14	<7.5	<11	<11	<15	<8.7
Effluent - pre-Carbon	Precarbon-123009	12/30/2009	<1,600	<4,000	<1,300	<1,300	<1,300	<1,300	<220	<1,100	130,000	1,900	<1,800	3,800	<2,500	<1,400
Effluent - post-Carbon	Postcarbon-123009	12/30/2009	<9.8	<24	<8.1	22	190	<7.9	<1.3	16 B	51	<7.5	16	13	<15	<8.7
Carbon change-out January 22, 2010.																
Effluent - pre-Carbon	Pre Carbon-012710	1/27/2010	<980	<2,400	<810	<790	<790	<790	<130	<690	60,000	1,200	<1,100	1,800	<1,500	<870
Effluent - post-Carbon	Post Carbon-012710	1/27/2010	<9.8	<24	<8.1	<7.9	<7.9	<7.9	<1.3	<7.0	<14	<7.5	<11	<11	<15	<8.7
Effluent - pre-Carbon	Pre Carbon 022510	2/25/2010	<460	<1,100	<380	<370	<370	<370	<1,000	<330	62,000	<350	<510	1,800	<720	<480
Effluent - post-Carbon	Post Carbon 022510	2/25/2010	<9.8	<24	<8.1	<7.9	<7.9	<7.9	<33	<6.9	<14	<7.5	<11	22	<15	<8.7
Effluent - pre-Carbon	Pre Carbon 032510	3/25/2010	<290	<700	<240	<230	<230	<230	<38	<200	49,000	<220	<320	1,700	<450	<250
Effluent - post-Carbon	Post Carbon 032510	3/25/2010	<9.8	<24	<8.1	<7.9	<7.9	<7.9	<1.3	17	<14	<7.5	<11	<11	<15	<8.7
Effluent - pre-Carbon	Pre Carbon 042910	4/29/2010	<410	<1,000	<340	<340	<340	<340	--	<290	49,000	<320	<460	1,900	<650	<370
Effluent - post-Carbon	Post Carbon 042910	4/29/2010	<9.8	240	<8.1	<7.9	<7.9	<7.9	--	8.4	<14	13	<11	<11	<15	<8.7
Effluent - pre-Carbon	PRECARBON_052510	5/25/2010	<400	<990	<330	<330	<330	<330	--	<290	66,000	<310	<450	1,800	<630	<360
Effluent - post-Carbon	POSTCARBON_052510	5/25/2010	<9.8	56	<8.1	<7.9	<7.9	<7.9	--	8.0	<14	<7.5	<11	<11	<15	<8.7
Effluent - pre-Carbon	PreCarbon_062910	6/29/2010	<350	<850	<290	<280	<280	<280	--	<250	58,000	<270	<390	1,400	<540	<310
Effluent - post-Carbon	PostCarbon_062910	6/29/2010	<9.8	<24	<8.1	<7.9	<7.9	<7.9	--	8.3	<14	<7.5	<11	<11	<15	<8.7
Effluent - pre-Carbon	Pre Carbon-072910	7/29/2010	<560	<1,400	<460	<450	<450	<450	--	<400	62,000	<430	<620	1,900	<880	<500
Effluent - post-Carbon	Post Carbon-072910	7/29/2010	<20	<50	40	42	1700	<16	--	<14	140	<16	1,500	1,500	<32	<18
Effluent - pre-Carbon	Pre Carbon 082510	8/25/2010	<500	<1200	<410	<400	200 J	<400	--	<350	55,000	<380	<550	1,800	<780	<440
Effluent - post-Carbon	Post Carbon 082510	8/25/2010	<9.8	<24	<8.1	<7.9	<7.9	<7.9	--	<6.9	<14	<7.5	<11	<11	<15	<8.7
Carbon change-out August 19, 2010.																

Notes:

1. µg/m³ = Micrograms per cubic meter.
2. Samples analyzed by Modified EPA Method TO-15.
3. Only analytes detected in at least one sample are presented in this table.
4. -- = not analyzed
5. J = Estimated value. Analyte detected at a level less than the Reporting Limit (RL) and greater than or equal to the Method Detection Limit (MDL).

Table 3
Soil Comparison Table - 2006 and 2010 Investigations
NuStar Vancouver Facility

Sample I.D.	Collect Date	Sample Depth (feet)	PID Reading ppm	Soil Type	Tetrachloroethene (µg/kg)	Trichloroethene (µg/kg)	cis-1,2 Dichloroethene (µg/kg)
Sample Pairs for Comparison							
AGP-22-18	5/2/2006	18	8	silt	41,700	2,180	<184
CB-4 (18)	9/21/2010	18	<5	sand	2,000	<5	<5
AGP-22-38.5	5/2/2006	38.5	23	silt	26,400	4,090	261
CB-4 (38.5)	9/21/2010	38.5	17.8	silty sand	26,000	2,000	1,300
AGP-28-9	5/3/2006	9	853	silt	59,300	536	<218
CB-1(9)	9/20/2010	9	756	silt/fine sand	6,700,000	<4,000	<40
AGP-28-17.5	5/3/2006	17.5	68	silty sand	65,200	1,870	<403
CB-1(17.5)	9/20/2010	17.5	11.9	silty sand	10,000	93	<30
AGP-28-37.5	5/3/2006	37.5	<5	sand	262	<96.4	<96.4
CB-1(37.5)	9/20/2010	37.5	5.4	sand	200	69	34
AGP-29-9.5	5/4/2006	9.5	384	silt	1,320,000	<4,780	<4,780
CB-2 (9.5)	9/20/2010	9	1613	silt	130,000	<40	<40
AGP-29-18	5/4/2006	18	12	silt	14,900	<93	<93
CB-2 (18)	9/20/2010	18	<5	sand/silt lenses	19	<5	<5
AGP-29-28	5/4/2006	28	24	gravelly silt	821	<102	<102
CB-2 (28)	9/20/2010	28	<5	sand	15	<5	<5
AGP-29-42	5/4/2006	42	12	sandy silt/silt	4,140	1,330	198
CB-2 (42)	9/20/2010	42	11.4	sandy silt	42,000	4,700	1,900
Samples in New Locations							
CB-3 (9)	9/21/2010	9	1,101	silt	1,800	6.9	<5
CB-3(18)	9/21/2010	18	21.3	sand	24,000	180	<40
CB-3 (29)	9/21/2010	29	48	silt lense at 29 feet	34,000	720	230
CB-4 (28)	9/21/2010	28	7.4	sand	80	<5	<5
CB-1(29.5)	9/20/2010	29.5	286	silty sand	160,000	<40	<40

Notes:

Shaded indicates soil samples collected in saturated soils.

1. µg/kg = micrograms per kilogram
2. ppm = parts per million

Table 4
Groundwater Comparison Table - 2006 and 2010 Investigations
NuStar Vancouver Facility

Sample I.D.	Collect Date	Screened Interval (feet bgs)	Tetrachloroethene (µg/L)	Trichloroethene (µg/L)	cis-1,2 Dichloroethene (µg/L)	trans-1,2 Dichloroethene (µg/L)	1,1-Dichloroethene (µg/L)	Total DCE (µg/L)	Vinyl Chloride (µg/L)	Total Molar Ethenes (µmol/L)
Sample Pairs for Comparison										
AGP-22-35	5/2/2006	31-35	2,050	328	102	<10	<10	102	<10	15.9
CB-4 (35)	9/21/2010	31-35	680	170	110	6.4	<4.0	116.4	<4.0	6.60
AGP-22-45	5/2/2006	41-45	31,200	11,500	1,360	<250	<250	1,360	<250	289.7
CB-4(45)	9/21/2010	41-45	3,300	820	1,200	22	<15	1,222	100	40.4
AGP-28-35	5/3/2006	31-35	1,590	288	26.1	<5.0	<5.0	26.1	<5.0	12.1
CB-1 (35)	9/20/2010	31-35	650	170	46	<2.5	<2.5	46	<2.5	5.7
AGP-28-45	5/3/2006	41-45	4,360	2,710	2,570	34.0	75.5	2,679.5	88.0	76.0
CB-1 (45)	9/20/2010	41-45	1,400	1,700	1,400	20	53	1,473	40	37.2
AGP-29-35	5/4/2006	31-35	3,070	571	93.6	<10	<10	93.6	<10	23.8
CB-2 (35)	9/20/2010	31-35	62	16	35	<0.50	<0.5	35	0.66	0.87
AGP-29-45	5/4/2006	41-45	3,030	3,210	1,640	19.0	96.6	1,756	<10	60.8
CB-2 (45)	9/21/2010	41-45	500	1,000	770	8.2	23	801.2	39	19.52
CB-2 (45) Dup	9/21/2010	41-45	1,400	1,800	950	11	36	997	61	33.41
Groundwater Samples in New Location										
CB-3 (35)	9/21/2010	31-35	940	240	220	<4.0	<4.0	220	<4.0	9.77
CB-3 (45)	9/21/2010	41-45	690	270	280	5.8	4.5	290.3	26	9.63
2006 Average			7,550	3,101	965	27	86	1,003	88	80
2010 Average			1,140	648	530	13	31	550	46	18
Percent Decrease			85%	79%	45%	51%	64%	45%	48%	77%

Notes:

µmol/L= micromole per liter
µg/L = microgram per liter
bgs= below ground surface

Table 5
VOC Mass Removal
NuStar Terminals Services, Inc.
Vancouver, Washington

Sample Date	Post-Blower Pressure (in H ₂ O)	Air Flow Rate ⁽¹⁾ (cfm)	Total VOCs (mg/m ³)	VOC Removal (lb/day)
9/18/2008	28.0	370	1,769	58.8
10/15/2008	33.0	370	158	5.2
11/20/2008	27.0	370	89	3.0
12/18/2008	27.0	370	73	2.4
1/23/2009	30.0	235	70	1.5
2/20/2009	29.0	180	55	0.9
3/27/2009	29.0	240	70	1.5
4/27/2009	29.0	270	81	2.0
5/27/2009	29.0	270	51	1.2
6/26/2009	25.5	285	57	1.5
7/31/2009	25.5	306	51	1.4
8/28/2009	27.0	253	35	0.8
9/29/2009	27.0	260	52	1.2
10/27/2009	29.0	252	50	1.1
11/30/2009	27.0	300	178	4.8
12/30/2009	28.0	270	136	3.3
1/27/2010	26.0	290	63	1.6
2/25/2010	26.0	300	64	1.7
3/25/2010	24.0	325	51	1.5
4/29/2010	24.0	330	51	1.5
5/25/2010	24.0	342	68	2.1
6/29/2010	24.0	350	59	1.9
7/29/2010	25.0	360	64	2.1
8/25/2010	24.0	360	57	1.8

Date	Activity	VOC Removal Rate (lb/day)	Days of Operation	Approximate VOCs Removed (lbs)	Approximate Cumulative VOCs Removed (lbs)
9/17/2008	Startup				
9/18/2008	Sample	58.8	1	59	59
10/15/2008	Sample	20.0	27	540	600
11/20/2008	Sample	4.10	36	150	750
12/18/2008	Sample	2.69	28	75	830
1/23/2009	Sample	1.95	36	70	900
2/20/2009	Sample	1.18	27	32	930
3/27/2009	Sample	1.20	35	42	970
4/27/2009	Sample	1.74	31	54	1020
5/27/2009	Sample	1.60	30	48	1070
6/26/2009	Sample	1.36	30	41	1110
7/31/2009	Sample	1.43	35	50	1160
8/28/2009	Sample	0.8	35	28	1190
9/29/2009	Sample	1.2	32	39	1230
10/27/2009	Sample	1.1	32	37	1270
11/30/2009	Sample	4.8	28	134	1400
12/30/2009*	Sample	3.3	14	46	1450
1/27/2010	Sample	1.6	31	50	1500
2/25/2010	Sample	1.7	29	49	1550
3/25/2010	Sample	1.5	28	42	1590
4/29/2010	Sample	1.5	35	53	1640
5/25/2010	Sample	2.1	26	54.6	1690
6/29/2010	Sample	1.9	33	62.7	1750
7/29/2010	Sample	2.1	30	63	1810
8/25/2010	Sample	1.8	27	48.6	1860

Notes:

1. Air flow rate read from system gauge.
2. cfm = Cubic feet per minute
3. mg/m³ = Milligrams per cubic meter
4. lb/day = Pounds per day
5. lbs = Pounds
6. The system shut down twice during this monitoring period due to high water levels in the knockout drum. The days of operation reflects the number of days the system was understood to be out of operation.

Table 6
 Summary of PID Measurements
 NuStar Terminals Services, Inc.
 Vancouver, Washington

Sample ID	Depth (feet bgs)	PID Measurement (ppm)	Sample ID	Depth (feet bgs)	PID Measurement (ppm)
Pre-Interim Action Borings (2006)			Post Interim Action Borings (2010)		
AGP-22	2	<5	CB-4	5	<5
	4	<5		7.5	<5
	9	<5		10	<5
	10.5	<5		12.5	<5
	13	9		15	<5
	14	7		17.5	<5
	16.5	12		20	<5
	18	8		22.5	<5
	19.5	34		25	<5
	20.5	17		27.5	7.4
	22.5	<5			
24	12				
AGP-28	3.5	9	CB-1	5.5	<5
	7	152		7.5	<5
	8.5	295		8.5	<5
	9.5	853		9.5	756
	13	150		12.5	<5
	14.5	95		15	<5
	18	68		17.5	12
	19.5	84		19.5	<5
	22	84		22.5	<5
		25	<5		
		27.5	<5		
		29.5	286		
AGP-29	3	<5	CB-2	5	<5
	4.5	<5		7.5	9
	7	<5		10	1,613
	8	<5		12.5	220
	9	63		15	<5
	9.5	384		20	<5
	11.5	16		22.5	<5
	13	113		25	<5
	14.5	33		27	<5
	16	123		30	<5
	17.5	12			
	19.5	9			
	20.5	13			
22	8				
		CB-3	5.5	<5	
			7.5	<5	
			10	1,101	
			12.5	<5	
			15	<5	
			17.5	21	
			20	7	
			22.5	<5	
			25	<5	
			27.5	<5	
			28.5	48	
		30	<5		

Notes:

1. For comparison, adjacent boring pairs were completed at the same approximate location.
2. bgs= below ground surface.
3. ppm = parts per million; calibrated to 100 ppm isobutylene.

Table 7
Groundwater Analytical Results: Bioremediation Parameters
NuStar Vancouver Facility
Vancouver, Washington

Analyte	Analytical Method	MW-7				EX			MP-1			MW-9	MGMS2-40	CB-3 (35)	MW-12	M-19	MGMS1-40
		3/23/2009	3/16/2010	9/23/2010	9/23/2010 (DUP)	3/23/2009	3/16/2010	9/23/2010	3/23/2009	3/16/2010	9/23/2010	9/21/2010	9/21/2010	9/21/2010	10/19/2010	10/19/2010	10/19/2010
Total Metals (mg/L)																	
Iron	EPA 6010 B	<0.10	0.16	-	-	1.5	1.2	-	<0.10	<0.10	-	<0.10	1.3	320	-	-	-
Manganese	EPA 6010 B	2.5	0.63	-	-	5.7	1.4	-	3.2	0.99	-	3.6	1.6	5.8	-	-	-
Potassium	EPA 6010 B	-	-	-	-	-	-	-	-	-	-	9.9	20	61	-	-	-
Attenuation Chemistry (mg/L)																	
Alkalinity (total, as CaCO3)	SM 2320 B	130	26	-	-	38.0	<1	-	96.0	134	-	-	-	-	-	-	-
Ammonia (as N)	SM 4500-NH3 B/C	11	2.4	-	-	14	3.4	-	35	37	-	1.4	130	89	-	-	-
Nitrate-Nitrogen	EPA 300.0	56	99	-	-	43	89	-	210	990	-	89	560	580	59	19	390
Nitrite-Nitrogen	EPA 300.0	<0.10	<0.50	-	-	0.54	0.71	-	1.2	0.76	-	<0.10	<0.10	2	-	-	-
Sulfate	EPA 300.0	59	19	-	-	24	11	-	91	87	-	49	110	80	-	-	-
Total Organic Carbon	SM 5310 D	6.7	2.6	8.2	-	3.0	2.4	3.6	2.0	2.4	2	2.1	3.7	4.8	-	-	-
Total Phosphate	EPA 365.1	0.10	<0.10	-	-	0.36	0.36	-	<0.050	<0.10	-	-	-	-	-	-	-
Orthophosphate (as P)	SM 4500 P B/E	-	-	-	-	-	-	-	-	-	-	<0.10	<0.10	<0.10	-	-	-
Chloride	EPA 300.0	5.9	3.1	-	-	4.6	1.8	-	6.7	14	-	5.9	20	8.6	-	-	-
Sulfide	SM 4500 S2-D	-	<0.050	-	-	-	<0.050	-	-	<0.050	-	-	-	-	-	-	-
Methane	RSK-175M	0.312	0.149	0.28	0.303	0.346	0.0868	0.0913	0.0111	0.412	0.825	-	-	2.1	-	-	-
Ethane	RSK-175M	-	-	<0.001	<0.001	-	-	<0.001	-	-	<0.001	-	-	<0.001	-	-	-
Ethene	RSK-175M	-	<0.001	0.003	0.003	-	<0.001	<0.001	-	0.00247	<0.001	-	-	<0.001	-	-	-
CO2	SM 4500 C	-	-	-	-	-	-	-	-	-	-	-	-	38	-	-	-
Organic Acids (mg/L)																	
Acetic Acid	WCAS SOP 4130	-	-	-	-	-	-	-	-	-	-	-	-	<0.5	-	-	-
Butyric Acid	WCAS SOP 4130	-	-	-	-	-	-	-	-	-	-	-	-	<1	-	-	-
Lactic Acid	WCAS SOP 4130	-	-	-	-	-	-	-	-	-	-	-	-	<0.5	-	-	-
Propionic Acid	WCAS SOP 4130	-	-	-	-	-	-	-	-	-	-	-	-	<0.4	-	-	-
Field Parameters																	
Dissolved Oxygen (ppm)	-	0.69	1.37	0.64	0.64	0.47	0.88	0.93	1.05	0.89	0.53	0.51	2.05	-	-	-	-
ORP (mV)	-	-614.5	147.7	-483.4	-483.4	68.8	102.6	-521.6	127.3	83.2	-464	115.1	80.1	-	-	-	-
Chlorinated Ethenes (µg/L)																	
Tetrachloroethene	EPA 8260	3,300	550	750	740	1,400	150	2,400	1,200	1,500	730	140	3,500	940	-	-	-
Trichloroethene	EPA 8260	270	56	110	100	420	33	220	180	400	120	50	1,500	240	-	-	-
cis-1,2 dichloroethene	EPA 8260	420	180	690	700	50	20	90	89	410	41	2	480	220	-	-	-
Vinyl Chloride	EPA 8260	<15	<2.0	4.8	4.1	<5.0	<0.50	1.8	<4	10	<3	<0.50	5.4	<4.0	-	-	-

Notes:
mg/L = milligrams per Liter
µg/L = micrograms per Liter
ORP = Oxidation-Reduction Potential
mV = millivolts
ppm = parts per million
BOLD = Analyte detected above method reporting limit.
DUP = Duplicate sample

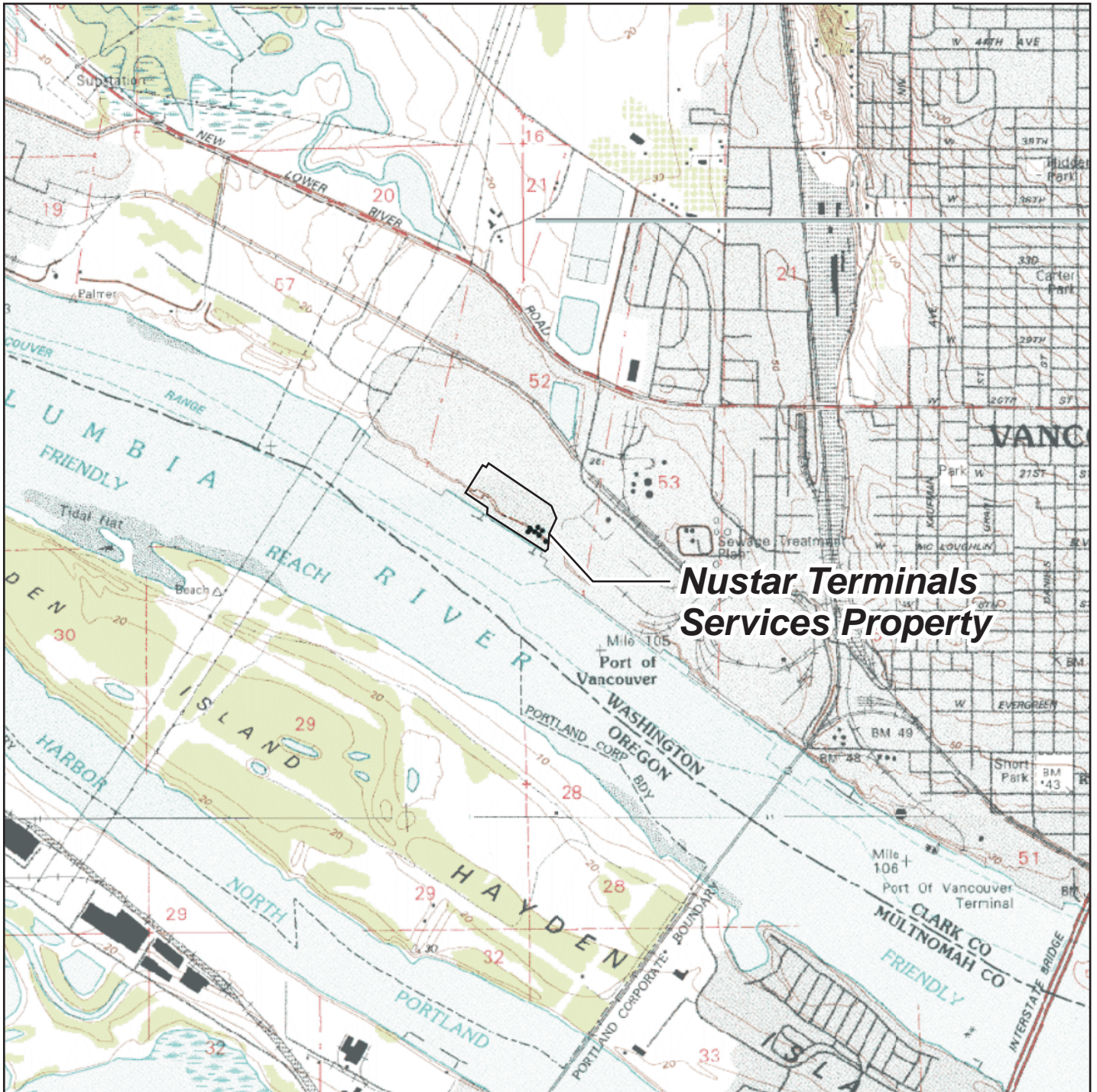

**Nustar Terminals
Services Property**

NOTES: 1) Base map prepared from USGS 7.5-minute quadrangles as provided by Topozone.
2) Property defined based on 2006 leasehold boundary.

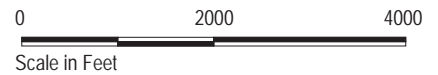

Vancouver



Property and Site Location Map

Interim Action Performance Evaluation
NuStar Terminals Services, Inc. Vancouver Facility
Vancouver, Washington

 Ash Creek Associates, Inc.
Environmental and Geotechnical Consultants

Project Number **1126-09**
November 2010

Figure
1

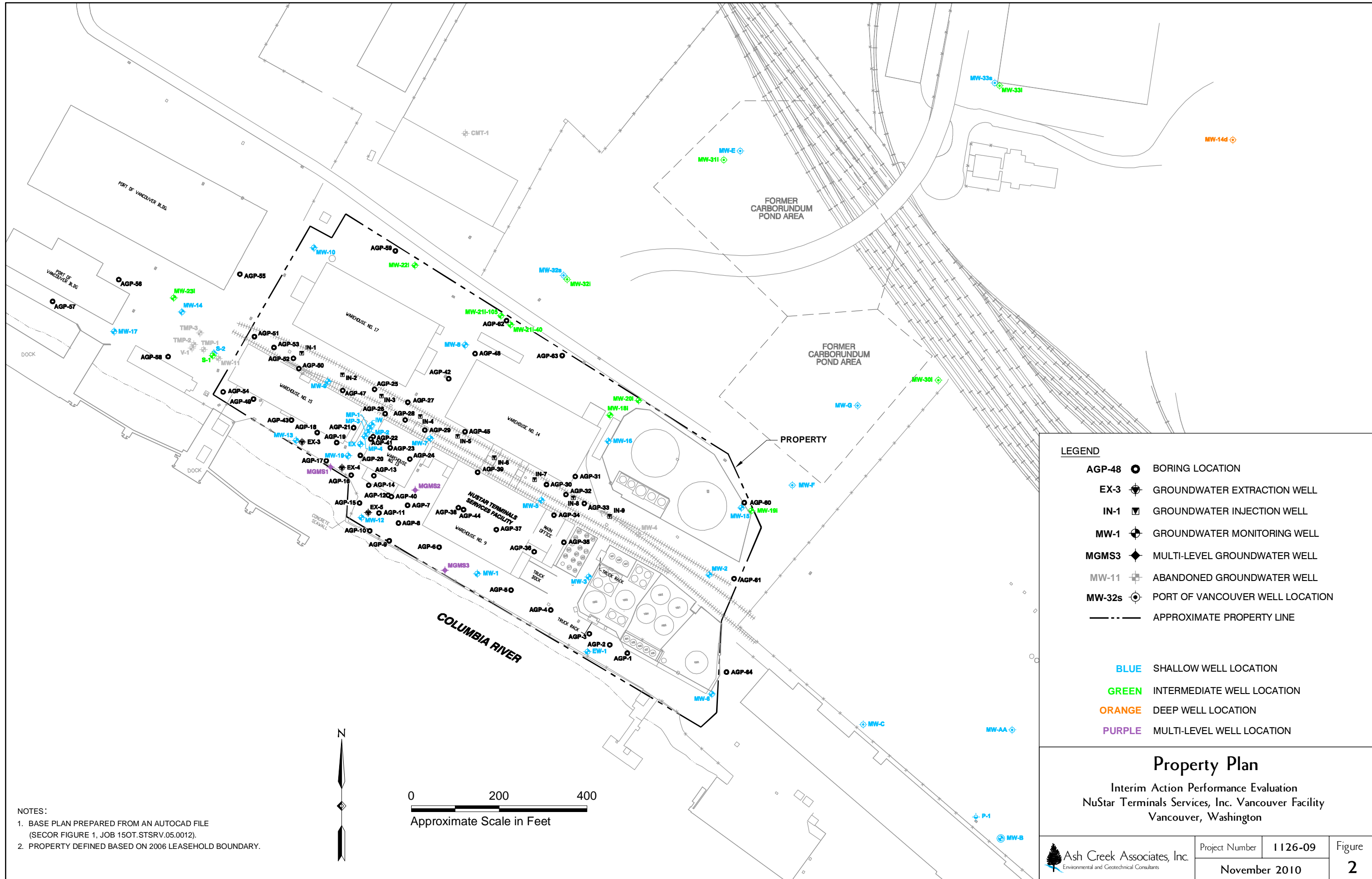

NOTES:
 1. BASE PLAN PREPARED FROM AN AUTOCAD FILE (SECOR FIGURE 1, JOB 150T.STSRV.05.0012).
 2. PROPERTY DEFINED BASED ON 2006 LEASEHOLD BOUNDARY.

LEGEND

- AGP-48 ● BORING LOCATION
- EX-3 ⚙️ GROUNDWATER EXTRACTION WELL
- IN-1 ▤ GROUNDWATER INJECTION WELL
- MW-1 ⚙️ GROUNDWATER MONITORING WELL
- MGMS3 ◆ MULTI-LEVEL GROUNDWATER WELL
- MW-11 ⚙️ ABANDONED GROUNDWATER WELL
- MW-32s ⚙️ PORT OF VANCOUVER WELL LOCATION
- APPROXIMATE PROPERTY LINE

- BLUE SHALLOW WELL LOCATION
- GREEN INTERMEDIATE WELL LOCATION
- ORANGE DEEP WELL LOCATION
- PURPLE MULTI-LEVEL WELL LOCATION

Property Plan
 Interim Action Performance Evaluation
 NuStar Terminals Services, Inc. Vancouver Facility
 Vancouver, Washington

Ash Creek Associates, Inc. <small>Environmental and Geotechnical Consultants</small>	Project Number 1126-09 November 2010	Figure 2
---	--	--------------------

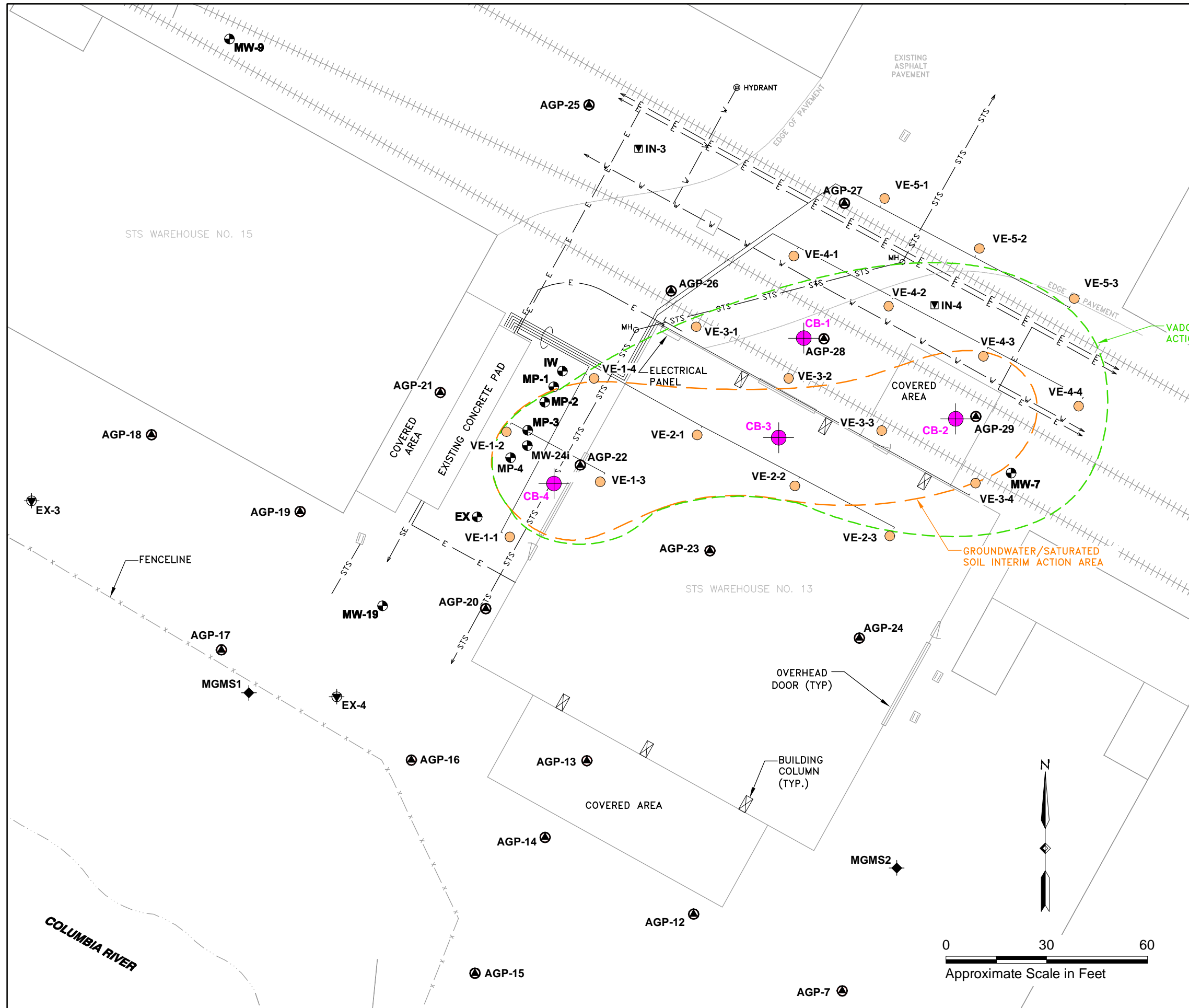

- LEGEND:**
- CB-1 BORING LOCATIONS
 - VE-1-2 VAPOR EXTRACTION WELL LOCATION
 - ⊙ AGP-11 PUSH-PROBE LOCATION
 - ⊖ EX-3 GROUNDWATER EXTRACTION WELL
 - ⊕ IN-1 GROUNDWATER INJECTION WELL
 - ⊗ MW-1 GROUNDWATER MONITORING WELL
 - ◆ MGMS3 MULTI-LEVEL GROUNDWATER WELL

- UTILITY LEGEND:**
- E — ELECTRICAL
 - STS — STORM SEWER
 - W — WATER
 - MHO MANHOLE

NOTES: 1. BASE PLAN PREPARED FROM AN AUTOCAD FILE (SECOR FIGURE 1, JOB 150T.STSRV.05.0012).
 2. UTILITY LOCATIONS SHOWN BASED ON SURFACE MARKINGS BY UTILITY LOCATOR.

Interim Action Area
 Interim Action Performance Evaluation
 NuStar Terminals Services, Inc. Vancouver Facility
 Vancouver, Washington

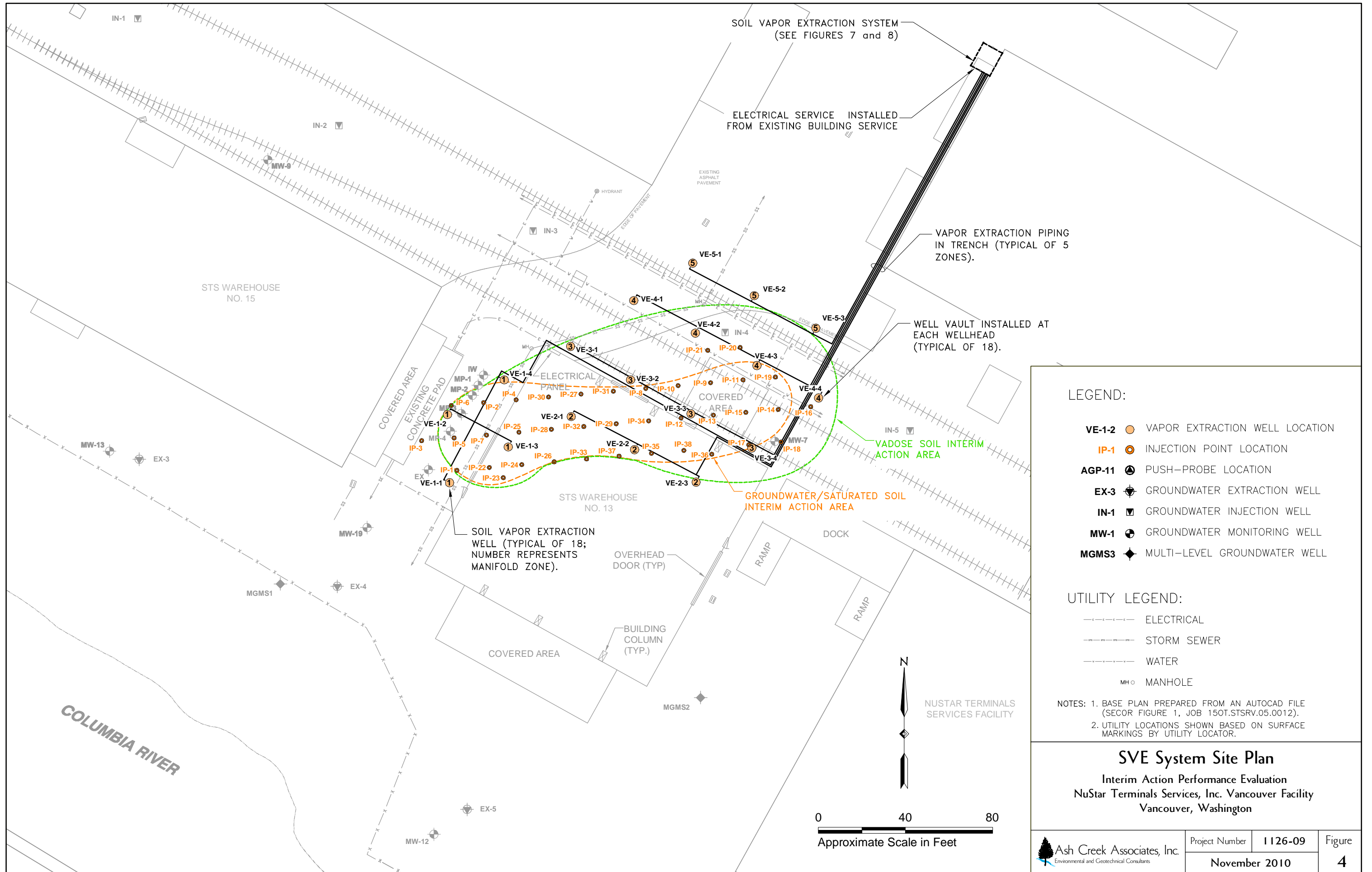

LEGEND:

- VE-1-2** ○ VAPOR EXTRACTION WELL LOCATION
- IP-1** ○ INJECTION POINT LOCATION
- AGP-11** ⊕ PUSH-PROBE LOCATION
- EX-3** ⊕ GROUNDWATER EXTRACTION WELL
- IN-1** ▽ GROUNDWATER INJECTION WELL
- MW-1** ⊕ GROUNDWATER MONITORING WELL
- MGMS3** ⊕ MULTI-LEVEL GROUNDWATER WELL

UTILITY LEGEND:

- ELECTRICAL
- STORM SEWER
- WATER
- MH ○ MANHOLE

NOTES: 1. BASE PLAN PREPARED FROM AN AUTOCAD FILE (SECOR FIGURE 1, JOB 150T.STSRV.05.0012).
 2. UTILITY LOCATIONS SHOWN BASED ON SURFACE MARKINGS BY UTILITY LOCATOR.

SVE System Site Plan
 Interim Action Performance Evaluation
 NuStar Terminals Services, Inc. Vancouver Facility
 Vancouver, Washington

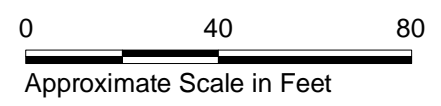

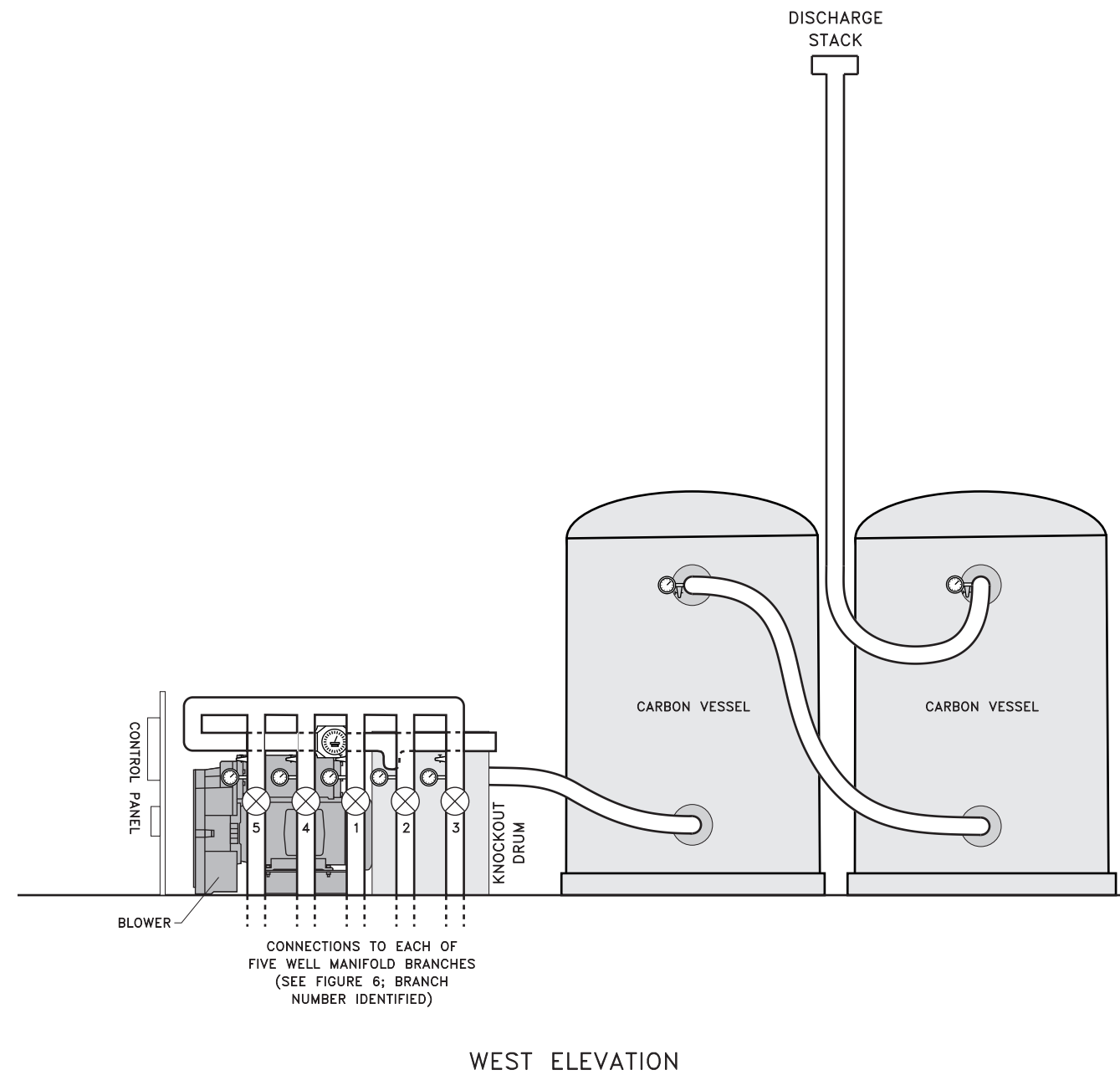
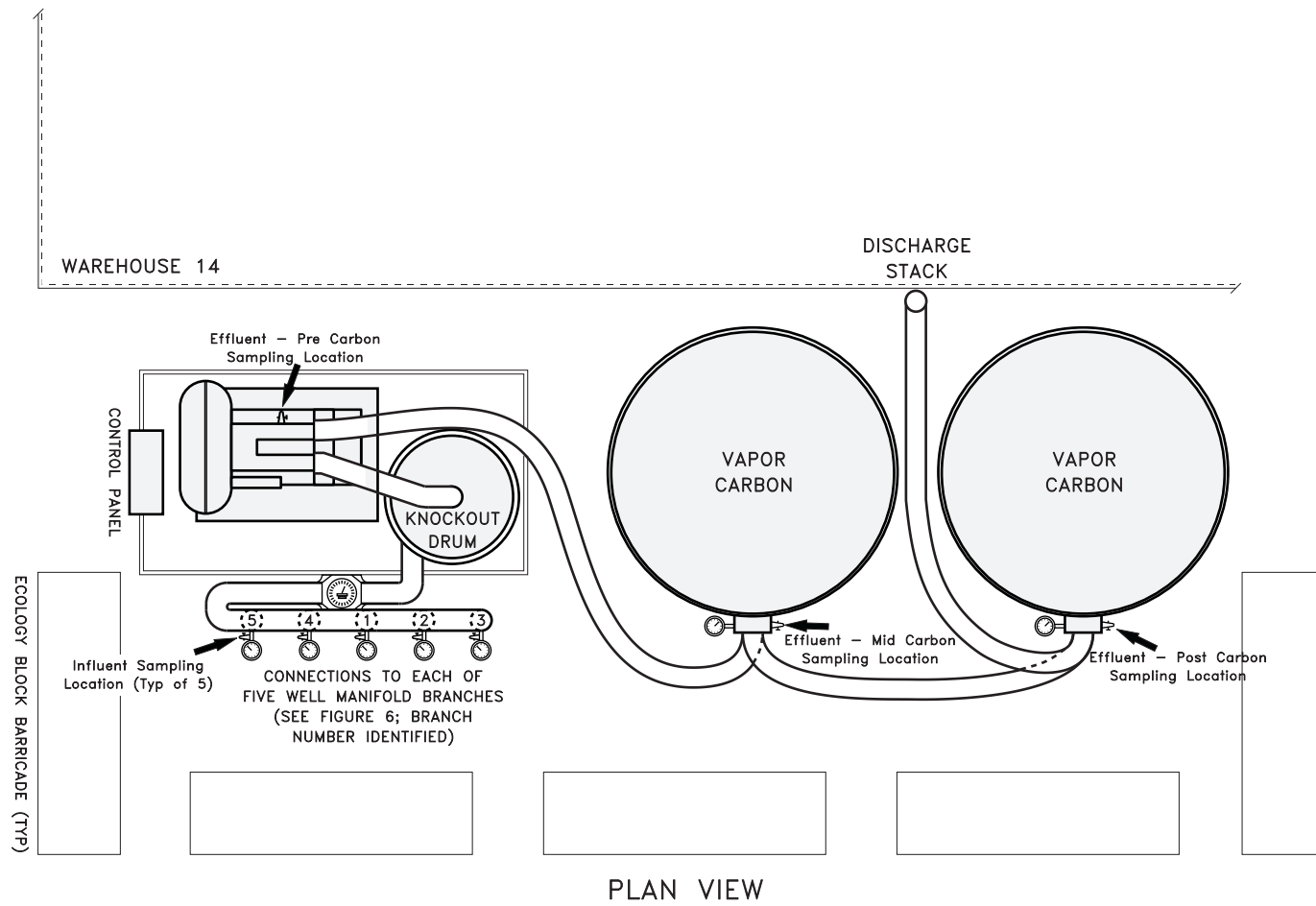

INSTALLATION PHOTOGRAPHS

Legend:

- ⊕ Sample Port (Sample/PID)
- ⊙ Pressure Gauge
- ⊗ Gate Valve
- ⊕ Flow Meter

SVE System Diagram

Interim Action Performance Evaluation
 NuStar Terminals Services, Inc. Vancouver Facility
 Vancouver, Washington

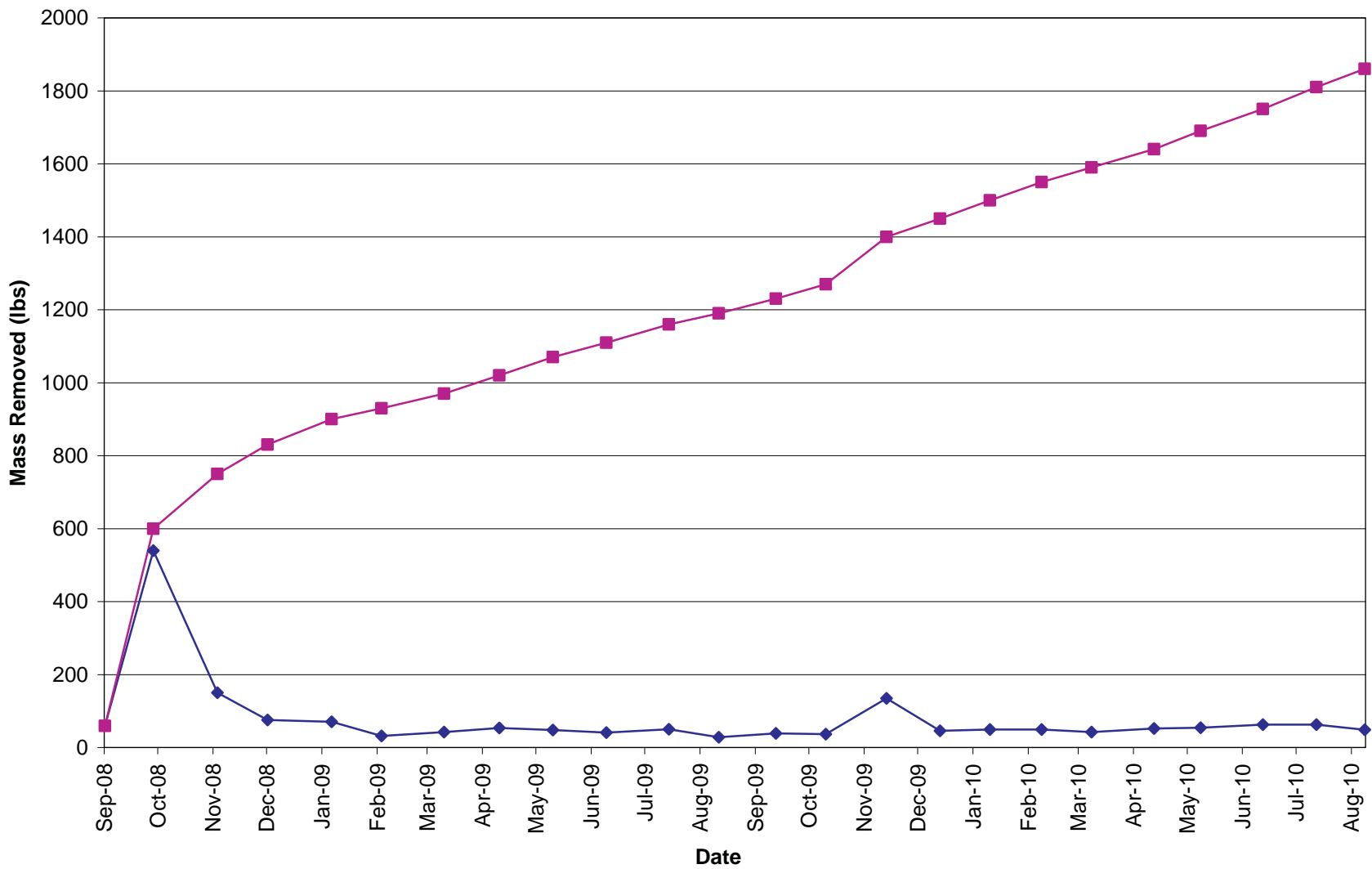

Legend:

- ◆— Approximate Volatile Organic Compounds (VOCs) Removed in Pounds
- Cumulative VOCs Removed in Pounds

SVE Interim Action VOC Mass Removal

Interim Action Performance Evaluation
 NuStar Terminals Services, Inc. Vancouver Facility
 Vancouver, Washington



Project Number	1126-09
November 2010	

Figure
6

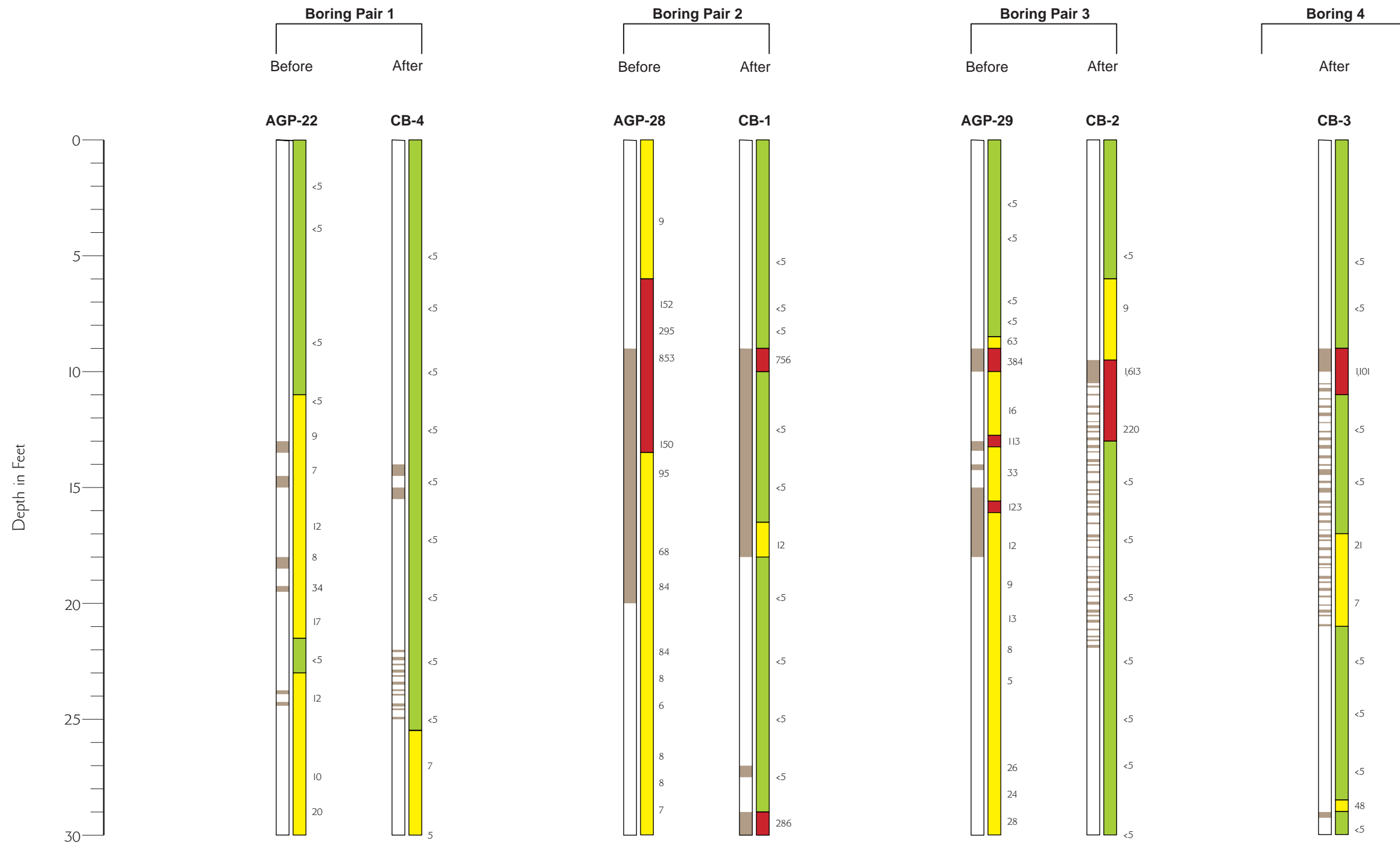

Legend:

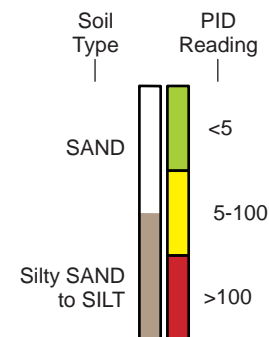

Before = May 2006, Prior to SVE

After = September 2010, After 2 Years of SVE

<h3>PID Comparison</h3> <p>Interim Action Performance Evaluation NuStar Terminals Services, Inc. Vancouver Facility Vancouver, Washington</p>		
 <p>Ash Creek Associates, Inc. Environmental and Geotechnical Consultants</p>	Project Number	1126-09
	November 2010	
		Figure 7

Appendix A

Field Methods and Sampling Procedures

1. PURPOSE AND SCOPE

This Standard Operating Procedure (SOP) provides instructions for standard field screening. Field screening results are used to aid in the selection of soil samples for chemical analysis. This procedure is applicable during all Ash Creek Associates (ACA) soil sampling operations.

Standard field screening techniques include the use of a photoionization detector (PID) to assess for volatile organic compounds (VOCs), for the presence of separate-phase petroleum hydrocarbons using a sheen test. These methods will not detect all potential contaminants, so selection of screening techniques shall be based on an understanding of the site history. The PID is not compound or concentration-specific, but it can provide a qualitative indication of the presence of VOCs. PID measurements are affected by other field parameters such as temperature and soil moisture. Other field screening methods, such as screening for dense non-aqueous phase liquid (DNAPL) using dye or UV light, are not considered "standard" and will be detailed in the site-specific sampling and analysis plan (SAP).

2. EQUIPMENT AND MATERIALS

The following materials are necessary for this procedure:

- PID with calibration gas (record daily calibration/calibration check in field notes);
- Plastic resealable bags (for PID measurement); and
- Glass jars or stainless steel bowls (for sheen testing).

3. METHODOLOGY

Each soil sample will be field screened for VOCs using a PID and for the presence of separate-phase petroleum hydrocarbons using a sheen test. If the presence of DNAPL is suspected, then screening using dye and UV light may also be completed. For information regarding screening using dye or UV light, refer to the site specific sampling and analysis plan.

PID lamps come in multiple sizes, typically 9.8, 10.6, and 11.7 electron volts (eV). The eV rating for the lamp must be greater than the ionization potential (in eV) of a compound in order for the PID to detect the compound. For petroleum hydrocarbons, a lamp of at least 9.8 eV should be used. For typical chlorinated alkenes (dichloroethene, trichloroethene, tetrachloroethene, or vinyl chloride.), a lamp of at least 10.6 eV should be used. The compatibility of the lamp size with the site constituents should be verified prior to the field event and will be detailed in the site-specific SAP.

PID Calibration Procedure: The PID used on-site should be calibrated daily or more frequently if needed. Calibration of the PID should be documented in field notes. Calibrations procedures should be conducted according to the manufacturer's instructions.

PID Screening Procedure:

- Place a representative portion (approximately one ounce) of freshly exposed, uncompacted soil into a clean resealable plastic bag.
- Seal the bag and break up the soil to expose vapors from the soil matrix.
- Allow the bag to sit to reach ambient temperature. Note: Ambient temperature and weather conditions/humidity should be recorded in field notes. Changes in ambient temperature and weather during the field work should also be recorded, as temperature and humidity can affect PID readings.
- Carefully insert the intake port of the PID into the plastic bag.
- Record the PID measurement in the field notes or boring logs.

Sheen Test Procedure:

- Following the PID screen, place approximately one ounce of freshly exposed, uncompacted soil into a clean glass jar or stainless steel bowl.

- Add enough water to cover the sample.
- Observe the water surface for signs of discoloration/sheen and characterize

No Sheen (NS)	No visible sheen on the water surface
Biogenic Film (BF)	Dull, platy/blocky or foamy film.
Slight Sheen (SS)	Light sheen with irregular spread, not rapid. May have small spots of color/iridescence. Majority of water surface not covered by sheen.
Moderate Sheen (MS)	Medium to heavy coverage, some color/iridescence, spread is irregular to flowing. Sheen covering a large portion of water surface.
Heavy Sheen (HS)	Heavy sheen coverage with color/iridescence, spread is rapid, entire water surface covered with sheen. Separate-phase hydrocarbons may be evident during sheen test.

1. PURPOSE AND SCOPE

This Standard Operating Procedure (SOP) describes the methods for collection of groundwater samples from monitoring wells applying low flow protocols. Low flow sampling is a method of collecting samples that does not require the removal of large volumes of water and therefore does not overly agitate the water, suspend particles, or potentially aspirate VOCs. Typical flow rates for low flow sampling range from 0.1 L/min to 0.5 L/min depending on site characteristics. The groundwater monitoring activities will consist of measuring water levels, purging and sampling groundwater, and measuring groundwater field parameters. This procedure is applicable during all Ash Creek Associates (ACA) low flow groundwater sampling activities.

2. EQUIPMENT AND MATERIALS

The following materials are necessary for this procedure:

- Traffic cones, tools, keys, and buckets/drums
- Water quality meter with calibration solutions (record daily calibration/calibration check in field notes)
- Sampling equipment (water level probe, pumps, tubing) and laboratory-supplied sample containers
- Field documentation materials
- Decontamination materials
- Personal protective equipment (as required by project Health and Safety Plan)

3. METHODOLOGY

Water Levels:

Water levels in the wells will be measured and recorded for the purpose of determining groundwater elevations and gradient. The wells will be opened and the water level allowed to equilibrate before the measurements are taken. Measurements of the depth to water will be made to the nearest 0.01 foot using an electronic probe.

Purging:

Purge using low-flow sampling equipment (e.g., bladder pump) at a rate no greater than the recharge rate of the groundwater to prevent water table drawdown. Unless specified otherwise in the project-specific sampling and analysis plan (SAP) the sample tubing/pump will be lowered to the middle of the screened interval. To assess the effectiveness of purging, groundwater field parameters (pH, electrical conductivity, and temperature) will be measured using a flow cell connected to the discharge tubing of the sample pump. Purging will be considered complete when the water quality parameters (i.e., pH, temperature, and specific conductance) stabilize within 10 percent for three consecutive 3-minute intervals. Consult the project-specific SAP for additional parameters and stabilization criteria. Purge water will be placed in Department of Transportation (DOT) approved drums.

Sample Collection:

After the purging of each well is complete, collect groundwater samples for chemical analyses using the same pump used for the well purging.

Low Yield Sampling Procedure:

If a well pumps dry during purging discontinue measurement of water quality parameters. Collect groundwater samples once the water level recovers to 90 percent of the pre-purge water column. Contact project manager in the event of slow recharge conditions. Always collect samples for VOC analysis as soon after recharge as possible.

1. PURPOSE AND SCOPE

This Standard Operating Procedure (SOP) describes the methods used for obtaining soil samples for chemical analysis for volatile organic compounds (VOCs) by EPA Method 5035A. Samples collected using the 5035A protocols are not exposed to the atmosphere after sampling thereby reducing the potential for loss of VOCs during sample transport, handling, and analysis. This procedure assumes the use of the PowerStop Handle sampler with disposable EasyDraw Syringes or Terra Core Samplers. This procedure is applicable during all Ash Creek Associates (ACA) soil sampling activities where the 5035A protocols are employed.

2. EQUIPMENT AND MATERIALS

The following materials are necessary for this procedure:

- Sampling equipment (PowerStop Handle, disposable EasyDraw Syringes, Terra Core Samplers)
- Laboratory-supplied sample containers (pre-weighed 40ml VOA vials including labels, preservative, stir bars, etc. [number and type as specified by the lab], two ounce jars)
 - Vials used from ACA stock must be weighed to confirm loss of reagents is less than 0.02 grams. Record vial tare weight in field notes. Discard vials with dates over 6 months old.
- Field documentation materials
- Decontamination materials
- Personal protective equipment (as required by Health and Safety Plan)

3. METHODOLOGY

The project-specific sampling and analysis plan (SAP) will define the specific requirements for 5035A methodology required for a particular site or by a regulatory agency.

Analytical Requirements

- VOCs must be analyzed within 14 days of collection.
- Field preserved samples (e.g., sodium bisulfate or methanol) must be maintained at 4° C.
- Sample collected without preservative (e.g., reagent water) must frozen or analyzed within 48 hours.

Collection of Samples

- When using the PowerStop Handle, clip the syringe into the handle in one of the three 5 gram positions. Use the heavy position for dense clay, the light position for dry sandy soil, and the medium position for all others.
- Using the handle, push the sampler into the soil to collect the sample. Continue pushing until the soil column has forced the plunger in the syringe to the stopping point or filled the sampler.
- Wipe all debris from the outside of the sampler. The soil plug should be flush with the mouth of the sampler. Remove any excess soil that extends beyond the mouth of the sampler.
- Extrude the 5 gram sample into vial and cap vial immediately. Hold vial at an angle when extruding to minimize splashing. Gently swirl vial for 10 seconds to break up soil particles (do not shake).
- When capping the vial, be sure to remove any soil or debris from the threads of the vial.
- Repeat process for each additional vial.
- Fill a two ounce container (to capacity) for percent total solids determination.

Additional Considerations

- Methanol contamination can occur from adjacent activities (e.g., exhaust from running equipment or vehicles, hot tar roofing, facility operations, etc). Collection and analysis of methanol field blank (e.g., additional methanol vial left open during period of sampling) is recommended.
- Acidification of carbonaceous soils with sodium bisulfate can cause effervescence and loss of VOCs.
- Certain volatile compounds such as 2-chloroethylvinyl ether may be lost by acidification.
- Acidification of certain soils with sodium bisulfate may cause the formation of acetone through oxidation of soil waxes and humic material (e.g., organic materials such as roots).

1. PURPOSE AND SCOPE

This Standard Operating Procedure (SOP) describes the methods for oversight of boring installation and soil and grab groundwater sampling using sonic drilling techniques. Subsurface soil cores may be obtained using this system for purposes of determining subsurface soil conditions and for obtaining soil samples for physical and/or chemical evaluation. Grab groundwater samples may be collected using temporary well screens. Groundwater monitoring wells may also be installed using sonic drilling methods to advance the wellbore. This procedure is applicable during Ash Creek Associates (Ash Creek) drilling activities using sonic drilling methods. In addition to the procedures described herein, state and/or local regulations for boring advancement and/or abandonment should be researched to identify requirements specific to the location of the field work for work being conducted outside of the state of Oregon.

2. EQUIPMENT AND MATERIALS

The following materials are necessary for this procedure:

- Traffic cones, measuring tape, spatula, and buckets/drums
- Sampling equipment (water level probe, pumps, tubing) and laboratory-supplied sample containers (if sample collection for laboratory analysis is desired)
- Field documentation materials
- Decontamination materials
- Personal protective equipment (as required by project Health and Safety Plan)

3. METHODOLOGY

Coring Procedure (Conducted by Drilling Subcontractor):

Sonic drilling advances a temporary casing while drilling, thereby minimizing communication between strata of different elevations during the drilling process. The sonic drilling technology combines harmonics (vibration) and rotation as the basis for tool advancement, and reduces the volume of IDW created during the completion of the boring. Advancement of the boring is conducted using an inner casing (a 6-inch-diameter core barrel) followed by an outer casing that sleeves over the inner casing. The core barrel advances 5-10 feet into the subsurface, followed by the outer casing. The core barrel is then removed from the borehole and the soil is bagged for preservation (and sampling) or for disposal. The core barrel is put back into the borehole and pushed another 5 to 10 feet. An additional 5- to 10-foot length of outer casing is added to the outer casing that is in the ground and it is advanced to meet the bottom of the core barrel. This process continues until total depth is reached. Soil cores are collected continuously to the full depth of the exploration unless otherwise specified in a project-specific sampling and analysis plan (SAP). Verify that the subcontractor decontaminates the sampling device prior to its initial use and following collection of each soil sample.

Logging and Soil Sample Collection:

The driller will remove the soil core from the sampler into a plastic tube bag by vibrating and moving the sampler so that the full soil core is laid flat within the bag. Inspect the soil core and expose for field screening, description, and placement into sample jars as needed by breaching the side of the sample bag. Soil samples will generally be collected for field screening and possible chemical analysis on two to five foot intervals unless otherwise specified in a project-specific SAP. The sampling interval will be determined in the field based on recovery, soil variability, and evidence of contamination. Complete field screening as

specified in SOP 2.1. Soil samples should be collected using different procedures for volatile or non-volatile analyses, as follows.

- **Volatile Analyses.** Sampling for volatile organics analysis (VOA) is different than other routine physical or chemical testing because of the potential loss of volatiles during sampling. To limit volatile loss, the soil sample must be obtained as quickly and as directly as possible. If a VOA sample is to be collected as part of a multiple analyte sample, the VOA sample portion will be obtained first. The VOA sample should be obtained from a discrete portion of the entire collected sample and should not be composited or homogenized. Sample bottles should be filled to capacity, with no headspace. Specific procedures for collecting VOA samples using the EPA Method 5035 are discussed in SOP 2.7.
- **Other Analyses.** Soil samples for non-volatile analyses will be thoroughly homogenized in a stainless steel bowl prior to bottling. Sample homogenizing is accomplished by identifying the selected sample depth interval based on discussions with the Project manager and/or project specific investigation work plan and manually mixing the soil sample from the specified depth interval in the stainless steel bowl with a clean sampling tool until a uniform mixture is achieved. The sample jar should be filled completely.

Any extra soil generated during probing activities will be placed in Department of Transportation (DOT)-approved drums or other project specific storage vessels, based on discussion with the Project Manager.

Grab Groundwater Sample Collection:

Collect grab groundwater samples by installing a temporary well casing in the boring (i.e., 1- to 2-inch PVC well casing with a 4- to 5-foot-long temporary screen). Design of the temporary well casing (including need for filter pack) should be developed based on discussions with the Project Manager and/or project specific investigation work plan. Obtain samples using the methods described in SOP 2.5. Record field parameters (e.g., temperature, conductivity, and pH) prior to sampling. Temporary well well casing should be removed from boring and any other materials added to the boring to support the grab groundwater sampling, such as filter pack or grout drilled out of hole prior to abandonment.

Backfilling the Excavation (Conducted by Drilling Subcontractor):

After sampling activities are completed, abandon each exploration in accordance with regulations and procedures specified for the state in which the work is being conducted. The abandonment procedure typically consists of filling the exploration with granular bentonite and hydrating the bentonite with water. Match the surface completion to the surrounding materials.

Appendix B

Boring Logs

Sample Descriptions

Classification of soils in this report is based on visual field and laboratory observations which include density/consistency, moisture condition, and grain size, and should not be construed to imply field nor laboratory testing unless presented herein. Visual-manual classification methods of ASTM D 2488 were used as an identification guide.

Soil descriptions consist of the following:

MAJOR CONSTITUENT with additional remarks; color, moisture, minor constituents, density/consistency.

Density/Consistency

Soil density/consistency in borings is related primarily to the Standard Penetration Resistance. Soil density/consistency in test pits and push probe explorations is estimated based on visual observation and is presented parenthetically on test pit and push probe exploration logs.

SAND and GRAVEL	Standard Penetration Resistance in Blows/Foot	SILT or CLAY	Standard Penetration Resistance in Blows/Foot	Approximate Shear Strength in TSF
<u>Density</u>		<u>Density</u>		
Very loose	0 - 4	Very soft	0 - 2	<0.125
Loose	4 - 10	Soft	2 - 4	0.125 - 0.25
Medium dense	10 - 30	Medium stiff	4 - 8	0.25 - 0.5
Dense	30 - 50	Stiff	8 - 15	0.5 - 1.0
Very dense	>50	Very Stiff	15 - 30	1.0 - 2.0
		Hard	>30	>2.0

Moisture

Dry	Little perceptible moisture.
Sl. Moist	Some perceptible moisture, probably below optimum.
Moist	Probably near optimum moisture content.
Wet	Much perceptible moisture, probably above optimum.

Minor Constituents

Minor Constituents	Estimated Percentage
Not identified in description	0 - 5
Slightly (clayey, silty, etc.)	5 - 12
Clayey, silty, sandy, gravelly	12 - 30
Very (clayey, silty, etc.)	30 - 50

Sampling Symbols

BORING AND PUSH-PROBE SYMBOLS

	Recovery
	No Recovery
	Temporarily Screened Interval
PID	Photoionization Detector Reading
W	Water Sample
	Sample Submitted for Chemical Analysis
NS	No Sheen
SS	Slight Sheen
MS	Moderate Sheen
HS	Heavy Sheen
BF	Biogenic Film

TEST PIT SOIL SAMPLES

	Grab (Jar)
	Bag
	Shelby Tube

Groundwater Observations and Monitoring Well Construction

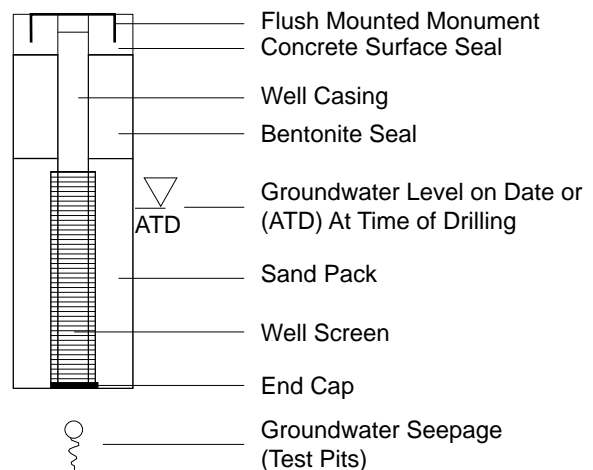

Key to Exploration Logs

Interim Action Performance Evaluation
NuStar Terminals Services, Inc. Vancouver Facility
Vancouver, Washington



Project Number 1126-09

October 2010

Figure
Key



Depth, feet	Core Interval/Recovery	Laboratory Sample ID	PID	Sheen	Lithologic Description	
0					Asphalt surface (4") over angular base rock (8").	
0-5					SAND; brown (10YR 4/3); dry, medium grained, loose.	
8-9			NS		Interbedded lenses of SAND/silty SAND from 8-9'.	
9-10			NS		SILT and fine SAND; pale brown (10YR 6/3), dry to slightly moist, medium stiff.	
10-15					Clayey SILT; brown (10YR 4/3), moist, soft.	
15-17.5					Interbedded sandy SILT lenses.	
17.5-19					Silty SAND, pale brown (10YR 6/3), slightly moist, medium dense.	
19-20					SAND with trace silt; yellowish brown (10YR 5/6), dry to slightly moist, medium dense.	
25-27					Clean, medium SAND; light yellowish brown (10YR 6/4), slightly moist, medium stiff.	
27-28					6-Inch silty SAND lens; brown (10YR 4/3).	
28-30					Fine to medium SAND; brown (10YR 4/3), slightly moist, slightly silty.	
30-31					Silty SAND; brown (10YR 4/3), moist, medium stiff.	
31-35					SAND; gray (10YR 5/1), wet, medium to coarse grained, medium dense.	
35					Wood debris.	
						 CB-1-35 (Water Sample)



Ash Creek Associates, Inc.
Environmental and Geotechnical Consultants

Interim Action Performance Evaluation
NuStar Terminals Services, Inc. Vancouver Facility
Vancouver, Washington

Boring Number: **CB-1**

Project Number: **1126-09**

Logged By: **A. Reese**

Date: **September 20, 2010**

Site Conditions: **Overcast, 60°**

Drilling Contractor: **Major Drilling**

Drilling Equipment: **Geoprobe 7720DT**

Sampler Type: **Macro Core**

Depth to Water (ATD): **30.5'**

Surface Elevation: **--**

Boring Details and Notes:

Depth, feet
Core Interval/Recovery
Laboratory Sample ID
PID
Sheen

Lithologic Description

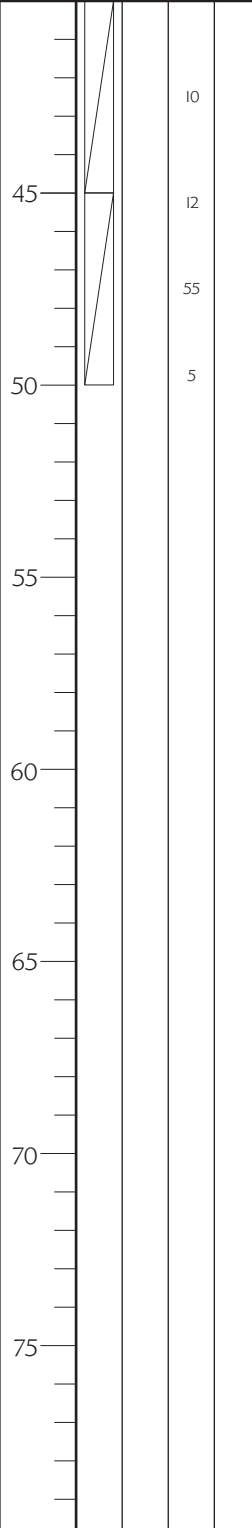

Fine SAND; grayish brown (10YR 4/2), wet, slightly silty, medium dense.

Sandy SILT; grayish brown (10YR 4/2), wet, stiff.

Fine, rounded GRAVEL in a sandy silt matrix; orange brown (10YR 6/6), wet, medium dense.

Bottom of Boring at 50.0' BGS.

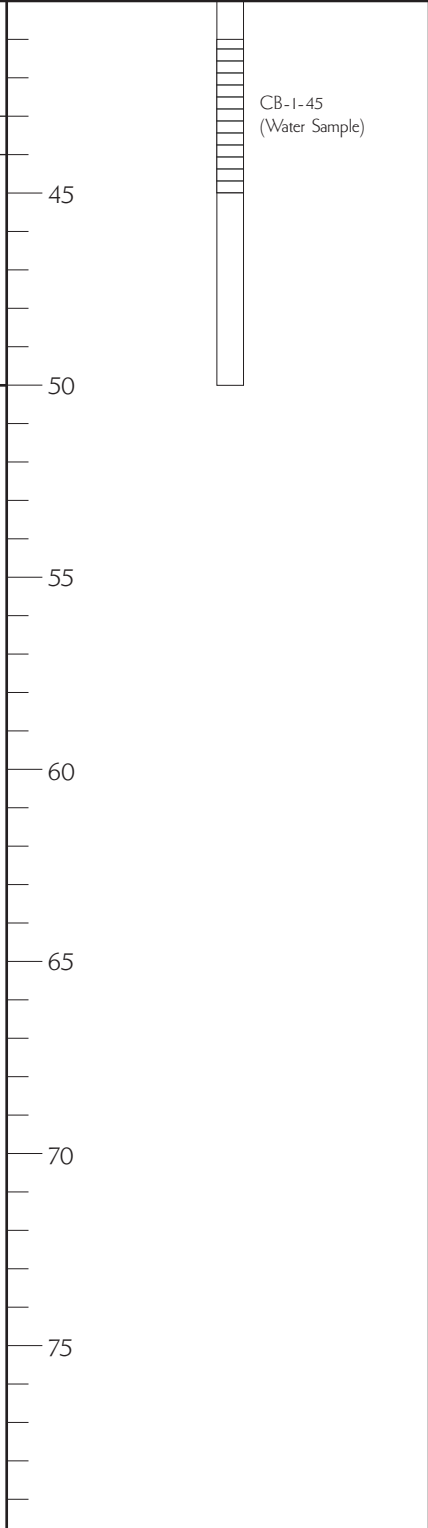

CB-1-45
(Water Sample)



Boring Details and Notes:

Depth, feet
Core Interval/Recovery
Laboratory Sample ID
PID
Sheen

Lithologic Description

5	<5		Asphalt surface (4") over angular base rock (8").	5	
9	9	CB-2-95	SAND; brown (10YR 4/3); dry to slightly moist, medium grained, loose.	9	
10	1613	CB-2-18	SILT; brown (10YR 4/3), slightly moist, slightly sandy, medium stiff.	10	
15	220		Interbedded SAND/SILT lenses, some oxidized, dry to moist, brown (silt), yellowish brown (sand), and reddish brown (sandy silt).	15	
20	<5		SAND; dark yellowish brown (10YR 3/4), dry, loose to medium dense.	20	
25	<5			25	
30	<5		SILT; brown (10YR 4/3), wet, medium stiff.	30	
35	23		SAND; brownish gray (10YR 5/2), wet, medium dense.	35	CB-2-35 (Water Sample)
<5	<5			<5	
<5	<5			<5	



Ash Creek Associates, Inc.
Environmental and Geotechnical Consultants

Interim Action Performance Evaluation
NuStar Terminals Services, Inc. Vancouver Facility
Vancouver, Washington

Boring Number: **CB-2**

Project Number: **1126-09**

Logged By: **A. Reese**

Date: **September 20, 2010**

Site Conditions: **Overcast, 60°**

Drilling Contractor: **Major Drilling**

Drilling Equipment: **Geoprobe 7720DT**

Sampler Type: **Macro Core**

Depth to Water (ATD): **30.6'**

Surface Elevation: **--**

Boring Details and Notes:

Depth, feet
Core Interval/Recovery
Laboratory Sample ID
PID
Sheen

Lithologic Description

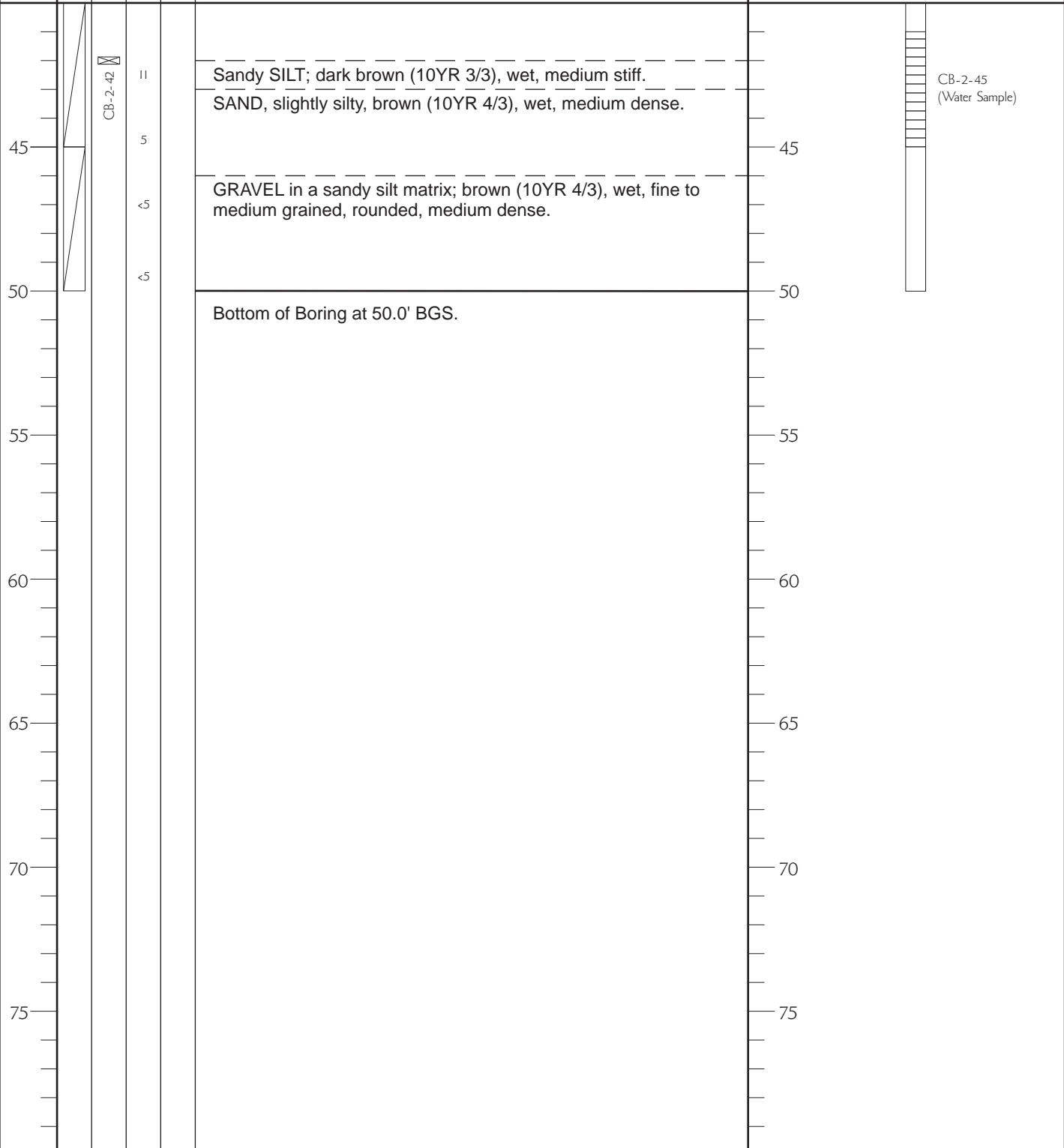



Depth, feet	Core Interval/Recovery	Laboratory Sample ID	PID	Sheen	Lithologic Description	
0					Asphalt surface (4") over angular base rock (8").	
0 - 10		CB-3-9			SAND; dark yellowish brown, dry, loose.	
10 - 12					SILT; brown (10YR 4/2), slightly moist, medium stiff.	
12 - 20		CB-3-18			SAND with interbedded lenses of clean, silty sand; brown to yellowish brown, slightly moist, loose.	
20 - 25					Becomes clean SAND with trace silt.	
25 - 30		CB-3-29			Silt lens. Becomes wet.	
30 - 35					SAND (SP); dark brown (10YR 3/3), wet, medium to coarse grained, trace fines, trace fine gravel.	
35 - 36						CB-3-35 (Water Sample)



Boring Details and Notes:

Depth, feet
Core Interval/Recovery
Laboratory Sample ID
PID
Sheen

Lithologic Description

45		22	NS	<p>Becomes fine grained.</p> <p>3-Inch SILT lens (ML); brown (10YR 4/3), moist to wet, medium stiff, few plastic fines, few very fine sand.</p> <p>3-Inch SILT lens (as above).</p> <p>Becomes coarse grained SAND.</p>	45	
50		<5	NS	<p>Sandy GRAVEL (GW); medium gray (10YR 5/1), wet, medium dense.</p>	50	
				<p>Bottom of Boring at 50.0' BGS.</p>	55	
60					60	
65					65	
70					70	
75					75	



Boring Details and Notes:

Depth, feet	Core Interval/Recovery	Laboratory Sample ID	PID	Sheen	Lithologic Description	
					Asphalt surface (6") over angular base rock (6") over sandy GRAVEL (FILL). Cleared with air knife.	
	Air Knife				SAND; yellowish brown (10YR 5/6), dry, fine to medium grained, some gravel, loose.	
5			<5			
			<5		2-Inch GRAVEL lens.	
10			<5			
			<5		4-Inch GRAVEL lens.	
15			<5			
			<5		6-Inch SILT lens; brown (10YR 4/3), slightly moist, stiff.	
			<5		6-Inch SILT lens; brown (10YR 4/3), slightly moist, stiff.	
20		CB-4-18	<5			
			<5		Fine horizontal laminates of silty SAND within a sand matrix from 22-25'.	
25			<5			
			<5		SAND; reddish brown (5YR 5/6), slightly moist, fine to medium grained, medium dense.	
30		CB-4-28	7			
			5		Becomes wet.	
			<5		Some wood debris.	
			<5		Grades to silty SAND.	
35			<5			
			<5		Becomes grayish brown.	
		CB-4-385	18			
			<5			
						CB-4-35 (Water Sample)

Appendix C

Current and Historical Analytical Data

Table C-1
 2010 Groundwater Analytical Summary Tables - VOCs
 NuStar Terminals Services, Inc. Vancouver Facility

Sample ID	Collection Date	Parameter in µg/L (ppb)																						
		1,1,1,2-Tetrachloroethane	1,1,1-Trichloroethane	1,1,2,2-Tetrachloroethane	1,1,2-Trichloroethane	1,1-Dichloroethane	1,1-Dichloroethene	1,1-Dichloropropene	1,2,3-Trichlorobenzene	1,2,3-Trichloropropane	1,2,4-Trichlorobenzene	1,2,4-Trimethylbenzene	1,2-Dibromo-3-chloropropane	1,2-Dibromoethane	1,2-Dichlorobenzene	1,2-Dichloroethane	1,2-Dichloropropane	1,3,5-Trimethylbenzene	1,3-Dichlorobenzene	1,3-Dichloropropane	1,4-Dichlorobenzene	2,2-Dichloropropane	2,4-Chlorotoluene	
CB-1 (35)	9/20/2010	< 2.5	6	< 2.5	< 2.5	3.2	< 2.5	< 2.5	< 2.5	< 2.5	< 2.5	< 2.5	< 2.5	< 2.5	< 2.5	< 2.5	< 2.5	< 2.5	< 2.5	< 2.5	< 2.5	< 2.5	< 2.5	< 2.5
CB-1 (45)	9/20/2010	< 5.0	130	< 5.0	< 5.0	260	53	< 5.0	< 5.0	< 5.0	< 5.0	< 5.0	< 5.0	< 5.0	< 5.0	< 5.0	< 5.0	< 5.0	< 5.0	< 5.0	< 5.0	< 5.0	< 5.0	< 5.0
CB-2 (35)	9/20/2010	< 0.50	< 0.50	< 0.50	< 0.50	< 0.50	< 0.50	< 0.50	< 0.50	< 0.50	< 0.50	< 0.50	< 0.50	< 0.50	< 0.50	< 0.50	< 0.50	< 0.50	< 0.50	< 0.50	< 0.50	< 0.50	< 0.50	< 1.0
CB-2 (45)	9/21/2010 9/21/10 DUP	< 5.0 < 7.0	72 M 110 M	< 5.0 < 7.0	< 5.0 < 7.0	100 130	23 M 36 M	< 5.0 < 7.0	< 5.0 < 7.0	< 5.0 < 7.0	< 5.0 < 7.0	< 5.0 < 7.0	< 5.0 < 7.0	< 5.0 < 7.0	< 5.0 < 7.0	< 5.0 < 7.0	< 5.0 < 7.0	< 5.0 < 7.0	< 5.0 < 7.0	< 5.0 < 7.0	< 5.0 < 7.0	< 5.0 < 7.0	< 5.0 < 7.0	< 10 < 15
CB-3 (35)	9/21/2010	< 4.0	8.8	< 4.0	< 4.0	9	< 4.0	< 4.0	< 4.0	< 4.0	< 4.0	< 4.0	< 4.0	< 4.0	< 4.0	< 4.0	< 4.0	< 4.0	< 4.0	< 4.0	< 4.0	< 4.0	< 4.0	< 7.0
CB-3(45)	9/21/2010	--	11	< 3.0	< 3.0	28	4.5	--	--	--	--	--	< 3.0	< 3.0	< 3.0	< 3.0	--	< 3.0	--	< 3.0	--	< 3.0	--	--
CB-4 (35)	9/21/2010	< 4.0	4.4	< 4.0	< 4.0	6.6	< 4.0	< 4.0	< 4.0	< 4.0	< 4.0	< 4.0	< 4.0	< 4.0	< 4.0	< 4.0	< 4.0	< 4.0	< 4.0	< 4.0	< 4.0	< 4.0	< 4.0	< 7.0
CB-4 (45)	9/21/2010	< 15	62	< 15	< 15	41	< 15	< 15	< 15	< 15	< 15	< 15	< 15	< 15	< 15	< 15	< 15	< 15	< 15	< 15	< 15	< 15	< 15	< 25

Please refer to notes at end of table.

Table C-1
 2010 Groundwater Analytical Summary Tables - VOCs
 NuStar Terminals Services, Inc. Vancouver Facility

Sample ID	Collection Date	Parameter in µg/L (ppb)																					
		Benzene	Bromobenzene	Bromochloromethane	Bromodichloromethane	Bromoform	Bromomethane	Carbon Tetrachloride	Chlorobenzene	Chloroethane	Chloroform	Chloromethane	cis-1,2-Dichloroethene	cis-1,3-Dichloropropene	Dibromochloromethane	Dibromomethane	Dichlorodifluoromethane	Ethylbenzene	Hexachlorobutadiene	Isopropyl benzene	Methylene Chloride	Naphthalene	n-Butylbenzene
CB-1 (35)	9/20/2010	< 2.5	< 2.5	< 2.5	< 2.5	< 2.5	< 50	< 2.5	< 2.5	< 2.5	< 2.5	< 2.5	46	< 2.5	< 2.5	< 2.5	< 2.5	< 2.5	< 2.5	< 2.5	< 5.0	< 2.5	< 2.5
CB-1 (45)	9/20/2010	< 5.0	< 5.0	< 5.0	< 5.0	< 5.0	< 100	< 5.0	< 5.0	< 5.0	< 5.0	< 5.0	1400	< 5.0	< 5.0	< 5.0	< 5.0	< 5.0	< 5.0	< 5.0	< 5.0	< 5.0	< 5.0
CB-2 (35)	9/20/2010	< 0.50	< 0.50	< 0.50	< 0.50	< 0.50	< 20	< 0.50	< 0.50	< 0.50	< 0.50	< 0.50	35	< 0.50	< 0.50	< 0.50	< 0.50	< 0.50	< 0.50	< 0.50	< 0.50	< 0.50	< 0.50
CB-2 (45)	9/21/2010	< 5.0	< 5.0	< 5.0	< 5.0	< 5.0	< 100	< 5.0	< 5.0	< 5.0	< 5.0	< 5.0	770	< 5.0	< 5.0	< 5.0	< 5.0	< 5.0	< 5.0	< 5.0	< 5.0	< 5.0	< 5.0
	9/21/10 DUP	< 7.0	< 7.0	< 7.0	< 7.0	< 7.0	< 150	< 7.0	< 7.0	< 7.0	< 7.0	< 7.0	950	< 7.0	< 7.0	< 7.0	< 7.0	< 7.0	< 7.0	< 7.0	< 7.0	< 7.0	< 7.0
CB-3 (35)	9/21/2010	< 4.0	< 4.0	< 4.0	< 4.0	< 4.0	< 70	< 4.0	< 4.0	< 4.0	< 4.0	< 4.0	220	< 4.0	< 4.0	< 4.0	< 4.0	< 4.0	< 4.0	< 4.0	< 5.0	< 4.0	< 4.0
CB-3(45)	9/21/2010	--	--	--	< 3.0	< 3.0	< 60	< 3.0	< 3.0	< 3.0	< 3.0	< 3.0	280	< 3.0	< 3.0	--	--	--	--	--	< 5.0	--	--
CB-4 (35)	9/21/2010	< 4.0	< 4.0	< 4.0	< 4.0	< 4.0	< 70	< 4.0	< 4.0	< 4.0	< 4.0	< 4.0	110	< 4.0	< 4.0	< 4.0	< 4.0	< 4.0	< 4.0	< 4.0	< 5.0	< 4.0	< 4.0
CB-4 (45)	9/21/2010	< 15	< 15	< 15	< 15	< 15	< 250	< 15	< 15	< 15	< 15	< 15	1200	< 15	< 15	< 15	< 15	< 15	< 15	< 15	< 15	< 15	< 15

Please refer to notes at end of table.

Table C-1
 2010 Groundwater Analytical Summary Tables - VOCs
 NuStar Terminals Services, Inc. Vancouver Facility

Sample ID	Collection Date	Parameter in µg/L (ppb)													
		n-Propylbenzene	O-Xylene	P,M-Xylene	p-Isopropyltoluene	sec-Butylbenzene	Styrene	tert-Butylbenzene	Tetrachloroethene	Toluene	trans-1,2-Dichloroethene	trans-1,3-Dichloropropene	Trichloroethene	Trichlorofluoromethane	Vinyl Chloride
CB-1 (35)	9/20/2010	< 2.5	< 2.5	< 2.5	< 2.5	< 2.5	< 2.5	< 2.5	650	< 2.5	< 2.5	< 2.5	170	< 2.5	< 2.5
CB-1 (45)	9/20/2010	< 5.0	< 5.0	< 5.0	< 5.0	< 5.0	< 5.0	< 5.0	1400	< 5.0	20	< 5.0	1700	< 5.0	40
CB-2 (35)	9/20/2010	< 0.50	< 0.50	< 1.0	< 0.50	< 0.50	< 0.50	< 0.50	62	< 0.50	< 0.50	< 0.50	16	< 0.50	0.66
CB-2 (45)	9/21/2010	< 5.0	< 5.0	< 5.0	< 5.0	< 5.0	< 5.0	< 5.0	500 M	< 5.0	8.2	< 5.0	1000 M	< 5.0	39 M
	9/21/10 DUP	< 7.0	< 7.0	< 7.0	< 7.0	< 7.0	< 7.0	< 7.0	1400 M	< 7.0	11	< 7.0	1800 M	< 7.0	61 M
CB-3 (35)	9/21/2010	< 4.0	< 4.0	< 4.0	< 4.0	< 4.0	< 4.0	< 4.0	940	< 4.0	< 4.0	< 4.0	240	< 4.0	< 4.0
CB-3(45)	9/21/2010	--	--	--	--	--	--	--	690	--	5.8	< 3.0	270	< 3.0	26
CB-4 (35)	9/21/2010	< 4.0	< 4.0	< 4.0	< 4.0	< 4.0	< 4.0	< 4.0	680	< 4.0	6.4	< 4.0	170	< 4.0	< 4.0
CB-4 (45)	9/21/2010	< 15	< 15	< 15	< 15	< 15	< 15	< 15	3300	< 15	22	< 15	820	< 15	100

Notes:

1. Concentrations in micrograms per kilogram (µg/Kg) parts per billion (ppb).
2. < = Not detected at corresponding numerical limit.
3. **Bolded** values indicate analyte detected above laboratory method detection limits (MDLs).
4. M = The relative percent difference (RPD) values between the sample and the duplicate were outside of acceptable control limits.
5. -- = Compound not reported or sample not analyzed.

Table C-2
 2010 Soil Analytical Summary Tables - VOCs
 NuStar Terminals Services, Inc. Vancouver Facility

Sample ID	Collection Date	Sample Depth (feet)	Parameter in mg/Kg (ppm)													
			Dichlorodifluoromethane	Chloromethane	Vinyl Chloride	Bromomethane	Chloroethane	Trichlorofluoromethane	1,1-Dichloroethene	Methylene Chloride	trans-1,2-Dichloroethene	1,1-Dichloroethane	2,2-Dichloropropane	cis-1,2-Dichloroethene	Chloroform	Bromochloromethane
CB-1 (9)	9/20/2010	9	<0.040	<0.040	<0.040	<5.0 RL1	<0.040	<0.040	<0.040	<0.040	<0.040	<0.040	<0.040	<0.040	<0.040	<0.040
CB-1 (29.5)	9/20/2010	29.5	<0.040	<0.040	<0.040	<2.0 RL1	<0.040	<0.040	<0.040	<0.040	<0.040	<0.040	<0.040	<0.040	<0.040	<0.040
CB-1 (17.5)	9/20/2010	17.5	<0.030	<0.030	<0.030	<0.600	<0.030	<0.030	<0.030	<0.030	<0.030	<0.030	<0.030	<0.030	<0.030	<0.030
CB-1 (37.5)	9/20/2010	37.5	<0.005	<0.005	<0.005	<0.020	<0.005	<0.005	<0.005	0.0057	<0.005	<0.005	<0.005	0.034	<0.005	<0.005
CB-2 (9.5)	9/20/2010	9.5	<0.040	<0.040	<0.040	<0.800 RL1	<0.040	<0.040	<0.040	<0.040	<0.040	<0.040	<0.040	<0.040	<0.040	<0.040
CB-2 (18)	9/20/2010	18	<0.005	<0.005	<0.005	<0.020	<0.005	<0.005	<0.005	0.0056	<0.005	<0.005	<0.005	<0.005	<0.005	<0.005
CB-2 (28)	9/20/2010	28	<0.005	<0.005	<0.005	<0.020	<0.005	<0.005	<0.005	<0.005	<0.005	<0.005	<0.005	<0.005	<0.005	<0.005
CB-2 (42)	9/20/2010	42	<0.040	<0.040	<0.040	<0.800 RL1	<0.040	<0.040	0.062	<0.040	0.049	0.270	<0.040	1.90	<0.040	<0.040
CB-3 (9)	9/21/2010	9	<0.005	<0.005	<0.005	<0.020	<0.005	<0.005	<0.005	<0.005	<0.005	<0.005	<0.005	<0.005	<0.005	<0.005
CB-3 (18)	9/21/2010	18	<0.040	<0.040	<0.040	<1.0 RL1	<0.040	<0.040	<0.040	<0.040	<0.040	<0.040	<0.040	<0.040	<0.040	<0.040
CB-3 (29)	9/21/2010	29	<0.040	<0.040	<0.040	<0.800 RL1	<0.040	<0.040	<0.040	<0.040	<0.040	<0.040	<0.040	0.230	<0.040	<0.040
CB-4 (18)	9/21/2010	18	<0.005	<0.005	<0.005	<0.020	<0.005	<0.005	<0.005	<0.005	<0.005	<0.005	<0.005	<0.005	<0.005	<0.005
CB-4 (28)	9/21/2010	28	<0.005	<0.005	<0.005	<0.020	<0.005	<0.005	<0.005	<0.005	<0.005	<0.005	<0.005	<0.005	<0.005	<0.005
CB-4 (38.5)	9/21/2010	38.5	<0.040	<0.040	<0.040	<0.800	<0.040	<0.040	<0.040	<0.040	<0.040	<0.040	<0.040	1.30	<0.040	<0.040

Please refer to notes at end of table

Table C-2
 2010 Soil Analytical Summary Tables - VOCs
 NuStar Terminals Services, Inc. Vancouver Facility

Sample ID	Collection Date	Parameter in mg/Kg (ppm)										
		1,1,1-Trichloroethane	1,1-Dichloropropene	1,2-Dichloroethane	Carbon Tetrachloride	Benzene	Trichloroethene	1,2-Dichloropropane	Bromodichloromethane	Dibromomethane	cis-1,3-Dichloropropene	Toluene
CB-1 (9)	9/20/2010	<0.004	<0.040	<0.040	<0.040	<0.040	<4.0	<0.040	<0.040	<0.040	<0.040	<0.040
CB-1 (29.5)	9/20/2010	<0.040	<0.040	<0.040	<0.040	<0.040	<0.040	<0.040	<0.040	<0.040	<0.040	<0.040
CB-1 (17.5)	9/20/2010	<0.030	<0.030	<0.030	<0.030	<0.030	0.093	<0.030	<0.030	<0.030	<0.030	<0.030
CB-1 (37.5)	9/20/2010	<0.005	<0.005	<0.005	<0.005	<0.005	0.069	<0.005	<0.005	<0.005	<0.005	<0.005
CB-2 (9.5)	9/20/2010	<0.040	<0.040	<0.040	<0.040	<0.040	<0.040	<0.040	<0.040	<0.040	<0.040	<0.040
CB-2 (18)	9/20/2010	<0.005	<0.005	<0.005	<0.005	<0.005	<0.005	<0.005	<0.005	<0.005	<0.005	<0.005
CB-2 (28)	9/20/2010	<0.005	<0.005	<0.005	<0.005	<0.005	<0.005	<0.005	<0.005	<0.005	<0.005	<0.005
CB-2 (42)	9/20/2010	0.300	<0.040	<0.040	<0.040	<0.040	4.7	<0.040	<0.040	<0.040	<0.040	<0.040
CB-3 (9)	9/21/2010	<0.005	<0.005	<0.005	<0.005	<0.005	0.0069	<0.005	<0.005	<0.005	<0.005	<0.005
CB-3 (18)	9/21/2010	<0.040	<0.040	<0.040	<0.040	<0.040	0.180	<0.040	<0.040	<0.040	<0.040	<0.040
CB-3 (29)	9/21/2010	<0.040	<0.040	<0.040	<0.040	<0.040	0.720	<0.040	<0.040	<0.040	<0.040	<0.040
CB-4 (18)	9/21/2010	<0.005	<0.005	<0.005	<0.005	<0.005	<0.005	<0.005	<0.005	<0.005	<0.005	<0.005
CB-4 (28)	9/21/2010	<0.005	<0.005	<0.005	<0.005	<0.005	<0.005	<0.005	<0.005	<0.005	<0.005	<0.005
CB-4 (38.5)	9/21/2010	0.120	<0.040	<0.040	<0.040	<0.040	2.0	<0.040	<0.040	<0.040	<0.040	<0.040

Please refer to notes at end of table

Table C-2
 2010 Soil Analytical Summary Tables - VOCs
 NuStar Terminals Services, Inc. Vancouver Facility

Sample ID	Collection Date	Parameter in mg/Kg (ppm)										
		trans-1,3-Dichloropropene	1,1,2-Trichloroethane	1,3-Dichloropropane	Tetrachloroethene	Dibromochloromethane	1,2-Dibromoethane	Chlorobenzene	1,1,1,2-Tetrachloroethane	Ethylbenzene	P,M-Xylene	O-Xylene
CB-1 (9)	9/20/2010	<0.040	<0.040	<0.040	6,700	<0.040	<0.040	<0.040	<0.004	<0.004	<0.040	<0.004
CB-1 (29.5)	9/20/2010	<0.040	<0.040	<0.040	160	<0.040	<0.040	<0.040	<0.040	<0.040	<0.040	<0.040
CB-1 (17.5)	9/20/2010	<0.030	<0.030	<0.030	10	<0.030	<0.030	<0.030	<0.030	<0.030	<0.030	<0.030
CB-1 (37.5)	9/20/2010	<0.005	<0.005	<0.005	0.2	<0.005	<0.005	<0.005	<0.005	<0.005	<0.005	<0.005
CB-2 (9.5)	9/20/2010	<0.040	<0.040	<0.040	130	<0.040	<0.040	<0.040	<0.040	<0.040	<0.040	<0.040
CB-2 (18)	9/20/2010	<0.005	<0.005	<0.005	0.019	<0.005	<0.005	<0.005	<0.005	<0.005	<0.005	<0.005
CB-2 (28)	9/20/2010	<0.005	<0.005	<0.005	0.015	<0.005	<0.005	<0.005	<0.005	<0.005	<0.005	<0.005
CB-2 (42)	9/20/2010	<0.040	<0.040	<0.040	42	<0.040	<0.040	<0.040	<0.040	<0.040	<0.040	<0.040
CB-3 (9)	9/21/2010	<0.005	<0.005	<0.005	1.8	<0.005	<0.005	<0.005	<0.005	<0.005	<0.005	<0.005
CB-3 (18)	9/21/2010	<0.040	<0.040	<0.040	24	<0.040	<0.040	<0.040	<0.040	<0.040	<0.040	<0.040
CB-3 (29)	9/21/2010	<0.040	<0.040	<0.040	34	<0.040	<0.040	<0.040	<0.040	<0.040	<0.040	<0.040
CB-4 (18)	9/21/2010	<0.005	<0.005	<0.005	2.0	<0.005	<0.005	<0.005	<0.005	<0.005	<0.005	<0.005
CB-4 (28)	9/21/2010	<0.005	<0.005	<0.005	0.08	<0.005	<0.005	<0.005	<0.005	<0.005	<0.005	<0.005
CB-4 (38.5)	9/21/2010	<0.040	<0.040	<0.040	26	<0.040	<0.040	<0.040	<0.040	<0.040	<0.040	<0.040

Please refer to notes at end of table

Table C-2
 2010 Soil Analytical Summary Tables - VOCs
 NuStar Terminals Services, Inc. Vancouver Facility

Sample ID	Collection Date	Parameter in mg/Kg (ppm)										
		Styrene	Isopropyl benzene	Bromoform	1,1,2,2-Tetrachloroethane	1,2,3-Trichloropropane	n-Propylbenzene	Bromobenzene	1,3,5-Trimethylbenzene	2+4-Chlorotoluene	tert-Butylbenzene	1,2,4-Trimethylbenzene
CB-1 (9)	9/20/2010	<0.040	<0.040	<0.040	<0.050	<0.040	<0.040	<0.040	<0.040	<0.070	<0.040	<0.040
CB-1 (29.5)	9/20/2010	<0.040	<0.040	<0.040	<0.040	<0.040	<0.040	<0.040	<0.040	<0.070	<0.040	<0.040
CB-1 (17.5)	9/20/2010	<0.030	<0.030	<0.030	<0.030	<0.030	<0.030	<0.030	<0.030	<0.060	<0.030	<0.030
CB-1 (37.5)	9/20/2010	<0.005	<0.005	<0.005	<0.005	<0.005	<0.005	<0.005	<0.005	<0.005	<0.005	<0.005
CB-2 (9.5)	9/20/2010	<0.040	<0.040	<0.040	<0.040	<0.040	<0.040	<0.040	<0.040	<0.070	<0.040	<0.040
CB-2 (18)	9/20/2010	<0.005	<0.005	<0.005	<0.005	<0.005	<0.005	<0.005	<0.005	<0.005	<0.005	<0.005
CB-2 (28)	9/20/2010	<0.005	<0.005	<0.005	<0.005	<0.005	<0.005	<0.005	<0.005	<0.005	<0.005	<0.005
CB-2 (42)	9/20/2010	<0.040	<0.040	<0.040	<0.040	<0.040	<0.040	<0.040	<0.040	<0.070	<0.040	<0.040
CB-3 (9)	9/21/2010	<0.005	<0.005	<0.005	<0.005	<0.005	<0.005	<0.005	<0.005	<0.005	<0.005	<0.005
CB-3 (18)	9/21/2010	<0.040	<0.040	<0.040	<0.040	<0.040	<0.040	<0.040	<0.040	<0.080	<0.040	<0.040
CB-3 (29)	9/21/2010	<0.040	<0.040	<0.040	<0.040	<0.040	<0.040	<0.040	<0.040	<0.070	<0.040	<0.040
CB-4 (18)	9/21/2010	<0.005	<0.005	<0.005	<0.005	<0.005	<0.005	<0.005	<0.005	<0.005	<0.005	<0.005
CB-4 (28)	9/21/2010	<0.005	<0.005	<0.005	<0.005	<0.005	<0.005	<0.005	<0.005	<0.005	<0.005	<0.005
CB-4 (38.5)	9/21/2010	<0.040	<0.040	<0.040	<0.040	<0.040	<0.040	<0.040	<0.040	<0.080	<0.040	<0.040

Please refer to notes at end of table

Table C-2
 2010 Soil Analytical Summary Tables - VOCs
 NuStar Terminals Services, Inc. Vancouver Facility

Sample ID	Collection Date	Parameter in mg/Kg (ppm)										
		sec-Butylbenzene	p-Isopropyltoluene	1,3-Dichlorobenzene	1,4-Dichlorobenzene	n-Butylbenzene	1,2-Dichlorobenzene	1,2-Dibromo-3-chloropropane	1,2,4-Trichlorobenzene	Hexachlorobutadiene	Naphthalene	1,2,3-Trichlorobenzene
CB-1 (9)	9/20/2010	<0.040	<0.004	<0.040	<0.040	<0.040	<0.040	<0.040	<0.040	<0.040	<0.040	<0.040
CB-1 (29.5)	9/20/2010	<0.040	<0.040	<0.040	<0.040	<0.040	<0.040	<0.040	<0.040	<0.040	<0.040	<0.040
CB-1 (17.5)	9/20/2010	<0.030	<0.030	<0.030	<0.030	<0.030	<0.030	<0.030	<0.030	<0.030	<0.030	<0.030
CB-1 (37.5)	9/20/2010	<0.005	<0.005	<0.005	<0.005	<0.005	<0.005	<0.005	<0.005	<0.005	<0.005	<0.005
CB-2 (9.5)	9/20/2010	<0.040	<0.040	<0.040	<0.040	<0.040	<0.040	<0.040	<0.040	<0.040	<0.040	<0.040
CB-2 (18)	9/20/2010	<0.005	<0.005	<0.005	<0.005	<0.005	<0.005	<0.005	<0.005	<0.005	<0.005	<0.005
CB-2 (28)	9/20/2010	<0.005	<0.005	<0.005	<0.005	<0.005	<0.005	<0.005	<0.005	<0.005	<0.005	<0.005
CB-2 (42)	9/20/2010	<0.040	<0.040	<0.040	<0.040	<0.040	<0.040	<0.040	<0.040	<0.040	<0.040	<0.040
CB-3 (9)	9/21/2010	<0.005	<0.005	<0.005	<0.005	<0.005	<0.005	<0.005	<0.005	<0.005	<0.005	<0.005
CB-3 (18)	9/21/2010	<0.040	<0.040	<0.040	<0.040	<0.040	<0.040	<0.040	<0.040	<0.040	<0.040	<0.040
CB-3 (29)	9/21/2010	<0.040	<0.040	<0.040	<0.040	<0.040	<0.040	<0.040	<0.040	<0.040	<0.040	<0.040
CB-4 (18)	9/21/2010	<0.005	<0.005	<0.005	<0.005	<0.005	<0.005	<0.005	<0.005	<0.005	<0.005	<0.005
CB-4 (28)	9/21/2010	<0.005	<0.005	<0.005	<0.005	<0.005	<0.005	<0.005	<0.005	<0.005	<0.005	<0.005
CB-4 (38.5)	9/21/2010	<0.040	<0.040	<0.040	<0.040	<0.040	<0.040	<0.040	<0.040	<0.040	<0.040	<0.040

- Notes:**
1. Concentrations in milligrams per kilogram (mg/Kg) parts per million (ppm).
 2. < = Not detected at corresponding numerical limit.
 3. **Bolded** values indicate analyte detected above laboratory method detection limits (MDLs).
 4. RL1 = The bromomethane reporting limit was raised due to a matrix effect.
 5. -- = Compound not reported or sample not analyzed.

Table C-3
Historical Soil Analytical Tables - VOCs
NuStar Terminals Services, Inc. Vancouver Facility

Sample ID	Collection Date	Sample Depth (feet)	Method	Parameter in mg/Kg (ppm)																
				Acetone	Acrylonitrile	Benzene	Bromobenzene	Bromodichloro-methane	Bromoform	Bromomethane	n-Butylbenzene	sec-Butylbenzene	tert-Butylbenzene	Carbon tetrachloride	Chlorobenzene	Chlorodibromo-methane	Chloroethane	2-Chloroethyl vinyl ether	Chloroform	Chloromethane
AGP-03-13	5/10/2006	13	8260B	--	--	--	--	--	--	--	--	--	--	--	--	--	--	--	--	
AGP-10-6.5	4/25/2006	6.5	8260B	--	--	--	<0.359	<0.359	<0.718	<3.59	--	--	--	<1.4	<0.359	--	<1.79	--	<0.359	<3.59
AGP-12-13	4/25/2006	13	8260B	--	--	--	--	--	--	--	--	--	--	--	--	--	--	--	--	--
AGP-07-46.5	4/25/2006	46.5	8260B	--	--	--	<0.0967	<0.0967	<0.193	<0.967	--	--	--	<0.387	<0.0967	--	<0.484	--	<0.0967	<0.967
AGP-08-37.5	4/24/2006	37.5	8260B	--	--	--	<0.0918	<0.0918	<0.184	<0.918	--	--	--	<0.367	<0.0918	--	<0.459	--	<0.0918	<0.918
AGP-09-48.5	4/25/2006	48.5	8260B	--	--	--	<0.091	<0.091	<0.184	<0.91	--	--	--	<0.364	<0.0910	--	<0.455	--	<0.0910	<0.910
AGP-10-49.5	4/26/2006	49.5	8260B	--	--	--	<0.0903	<0.0903	<0.181	<0.903	--	--	--	<0.361	<0.0903	--	<0.452	--	<0.0903	<0.903
AGP-11-33	4/26/2006	33	8260B	--	--	--	<0.0904	<0.0904	<0.181	<0.904	--	--	--	<0.361	<0.904	--	<0.452	--	<0.0904	<0.904
AGP-12-34.5	4/25/2006	34.5	8260B	--	--	--	--	--	--	--	--	--	--	--	--	--	--	--	--	--
AGP-12-37.5	4/25/2006	37.5	8260B	--	--	--	<0.657	<0.657	<0.001	<0.006	--	--	--	<0.002	<0.657	--	<0.003	--	<0.657	<6.570
AGP-12-48	4/25/2006	48	8260B	--	--	--	--	--	--	--	--	--	--	--	--	--	--	--	--	--
AGP-20-17.5	4/28/2005	17.5	8260B	--	--	--	--	--	--	--	--	--	--	--	--	--	--	--	--	--
AGP-21-13	5/1/2006	13	8260B	--	--	--	--	--	--	--	--	--	--	--	--	--	--	--	--	--
AGP-22-18	5/2/2006	18	8260B	--	--	--	--	--	--	--	--	--	--	--	--	--	--	--	--	--
AGP-23-12.5	5/8/2006	12.5	8260B	--	--	--	--	--	--	--	--	--	--	--	--	--	--	--	--	--
AGP-24-12	5/8/2006	12	8260B	--	--	--	--	--	--	--	--	--	--	--	--	--	--	--	--	--
AGP-26-18	5/3/2006	18	8260B	--	--	--	--	--	--	--	--	--	--	--	--	--	--	--	--	--
AGP-27-8.75	5/2/2006	8.75	8260B	--	--	--	--	--	--	--	--	--	--	--	--	--	--	--	--	--
AGP-28-9	5/3/2006	9	8260B	--	--	--	--	--	--	--	--	--	--	--	--	--	--	--	--	--
AGP-28-17.5	5/3/2006	17.5	8260B	--	--	--	--	--	--	--	--	--	--	--	--	--	--	--	--	--
AGP-29-9.5	5/4/2006	9.5	8260B	--	--	--	--	--	--	--	--	--	--	--	--	--	--	--	--	--
AGP-29-18	5/4/2006	18	8260B	--	--	--	--	--	--	--	--	--	--	--	--	--	--	--	--	--
AGP-32-14	5/9/2006	14	8260B	--	--	--	--	--	--	--	--	--	--	--	--	--	--	--	--	--
AGP-33-14	5/12/2006	14	8260B	--	--	--	--	--	--	--	--	--	--	--	--	--	--	--	--	--
AGP-35-18.5	5/15/2006	18.5	8260B	--	--	--	--	--	--	--	--	--	--	--	--	--	--	--	--	--
AGP-36-18	5/16/2006	18	8260B	--	--	--	--	--	--	--	--	--	--	--	--	--	--	--	--	--
AGP-38-24	5/11/2006	24	8260B	--	--	--	--	--	--	--	--	--	--	--	--	--	--	--	--	--
AGP-39-17.5	5/16/2006	17.5	8260B	--	--	--	--	--	--	--	--	--	--	--	--	--	--	--	--	--
AGP-42-17	6/19/2006	17	8260B	--	--	--	--	--	--	--	--	--	--	--	--	--	--	--	--	--
AGP-43-16.5	6/15/2006	16.5	8260B	--	--	--	--	--	--	--	--	--	--	--	--	--	--	--	--	--
AGP-45-7	6/23/2006	7	8260B	--	--	--	--	--	--	--	--	--	--	--	--	--	--	--	--	--
AGP-01-47.5	5/10/2006	47.5	8260B	--	--	--	--	--	--	--	--	--	--	--	--	--	--	--	--	--
AGP-02-43	5/11/2006	43	8260B	--	--	--	--	--	--	--	--	--	--	--	--	--	--	--	--	--
AGP-03-41.5	5/10/2006	41.5	8260B	--	--	--	--	--	--	--	--	--	--	--	--	--	--	--	--	--
AGP-04-38	5/5/2006	38	8260B	--	--	--	--	--	--	--	--	--	--	--	--	--	--	--	--	--
AGP-05-34	5/5/2006	34	8260B	--	--	--	--	--	--	--	--	--	--	--	--	--	--	--	--	--
AGP-06-48	5/2/2006	48	8260B	--	--	--	--	--	--	--	--	--	--	--	--	--	--	--	--	--
AGP-13-37.5	5/1/2006	37.5	8260B	--	--	--	--	--	--	--	--	--	--	--	--	--	--	--	--	--
AGP-14-49	4/27/2006	49	8260B	--	--	--	--	--	--	--	--	--	--	--	--	--	--	--	--	--
AGP-15-42.5	4/26/2006	42.5	8260B	--	--	--	--	--	--	--	--	--	--	--	--	--	--	--	--	--
AGP-16-37	4/27/2006	37	8260B	--	--	--	--	--	--	--	--	--	--	--	--	--	--	--	--	--
AGP-17-39	4/28/2006	39	8260B	--	--	--	--	--	--	--	--	--	--	--	--	--	--	--	--	--
AGP-18-37.5	4/28/2006	37.5	8260B	--	--	--	--	--	--	--	--	--	--	--	--	--	--	--	--	--
AGP-19-42.5	4/28/2006	42.5	8260B	--	--	--	--	--	--	--	--	--	--	--	--	--	--	--	--	--
AGP-20-43	5/1/2006	43	8260B	--	--	--	--	--	--	--	--	--	--	--	--	--	--	--	--	--
AGP-21-32.5	5/1/2006	32.5	8260B	--	--	--	--	--	--	--	--	--	--	--	--	--	--	--	--	--

Please refer to notes at end of table.

Table C-3
Historical Soil Analytical Tables - VOCs
NuStar Terminals Services, Inc. Vancouver Facility

Sample ID	Collection Date	Sample Depth (feet)	Method	Parameter in mg/Kg (ppm)																
				2-Chlorotoluene	4-Chlorotoluene	1,2-Dibromo-3-Chloropropane	1,2-Dibromoethane	Dibromomethane	1,2-Dichlorobenzene	1,3-Dichlorobenzene	1,4-Dichlorobenzene	Dichlorodifluoro-methane	1,1-Dichloroethane	1,2-Dichloroethane	1,1-Dichloroethene	cis-1,2-Dichloroethene	trans-1,2-Dichloroethene	1,2-Dichloropropane	1,1-Dichloropropene	1,3-Dichloropropane
AGP-03-13	5/10/2006	13	8260B	--	--	--	--	--	--	--	--	--	--	--	--	--	--	--	--	--
AGP-10-6.5	4/25/2006	6.5	8260B	--	--	--	<0.359	<0.359	<0.359	<0.359	<0.359	<3.59	<0.359	<0.359	<0.359	<0.359	<0.359	<0.359	<0.359	<0.359
AGP-12-13	4/25/2006	13	8260B	--	--	--	--	--	--	--	--	--	<0.0783	--	<0.0783	<0.0783	<0.0783	--	--	--
AGP-07-46.5	4/25/2006	46.5	8260B	--	--	--	<0.0967	<0.0967	<0.0967	<0.0967	<0.0967	<0.967	<0.0967	--	<0.0967	0.348	<0.0967	<0.0967	--	--
AGP-08-37.5	4/24/2006	37.5	8260B	--	--	--	<0.0918	<0.0918	<0.0918	<0.0918	<0.0918	<0.918	0.367	<0.0918	0.349	22.6	<0.206	<0.0918	--	--
AGP-09-48.5	4/25/2006	48.5	8260B	--	--	--	<0.0910	<0.0910	<0.0910	<0.0910	<0.0910	<0.910	<0.091	<0.0910	<0.091	0.599	<0.091	<0.0910	--	--
AGP-10-49.5	4/26/2006	49.5	8260B	--	--	--	<0.0903	<0.0903	<0.0903	<0.0903	<0.0903	<0.903	<0.0903	<0.0903	<0.0903	0.753	<0.0903	<0.0903	--	--
AGP-11-33	4/26/2006	33	8260B	--	--	--	<0.0904	<0.0904	<0.0904	<0.0904	<0.0904	<0.904	<0.0904	<0.0904	<0.0904	<0.0904	<0.0904	<0.0904	--	--
AGP-12-34.5	4/25/2006	34.5	8260B	--	--	--	--	--	--	--	--	--	<0.148	--	<0.148	0.618 J	<0.148	--	--	--
AGP-12-37.5	4/25/2006	37.5	8260B	--	--	--	<0.657	<0.657	<0.657	<0.657	<0.657	<6.570	8.47	<0.657	5.06	169	<3.52	<0.657	--	--
AGP-12-48	4/25/2006	48	8260B	--	--	--	--	--	--	--	--	--	<0.0927	--	<0.0814	2.11	<0.0814	--	--	--
AGP-20-17.5	4/28/2005	17.5	8260B	--	--	--	--	--	--	--	--	--	<0.107	--	<0.107	<0.107	<0.107	--	--	--
AGP-21-13	5/1/2006	13	8260B	--	--	--	--	--	--	--	--	--	<0.0939	--	<0.0939	<0.0939	<0.0939	--	--	--
AGP-22-18	5/2/2006	18	8260B	--	--	--	--	--	--	--	--	--	<0.184	--	<0.184	<0.184	<0.184	--	--	--
AGP-23-12.5	5/8/2006	12.5	8260B	--	--	--	--	--	--	--	--	--	<0.103	--	<0.103	<0.103	<0.103	--	--	--
AGP-24-12	5/8/2006	12	8260B	--	--	--	--	--	--	--	--	--	<0.0961	--	<0.0961	<0.0961	<0.0961	--	--	--
AGP-26-18	5/3/2006	18	8260B	--	--	--	--	--	--	--	--	--	<0.115	--	<0.115	<0.115	<0.115	--	--	--
AGP-27-8.75	5/2/2006	8.75	8260B	--	--	--	--	--	--	--	--	--	<0.0896	--	<0.0896	<0.0896	<0.0896	--	--	--
AGP-28-9	5/3/2006	9	8260B	--	--	--	--	--	--	--	--	--	<0.218	--	<0.218	<0.218	<0.218	--	--	--
AGP-28-17.5	5/3/2006	17.5	8260B	--	--	--	--	--	--	--	--	--	<0.403	--	<0.403	<0.403	<0.403	--	--	--
AGP-29-9.5	5/4/2006	9.5	8260B	--	--	--	--	--	--	--	--	--	<4.78	--	<4.78	<4.78	<4.78	--	--	--
AGP-29-18	5/4/2006	18	8260B	--	--	--	--	--	--	--	--	--	<0.093	--	<0.093	<0.093	<0.093	--	--	--
AGP-32-14	5/9/2006	14	8260B	--	--	--	--	--	--	--	--	--	<0.0984	--	<0.0984	<0.0984	<0.0984	--	--	--
AGP-33-14	5/12/2006	14	8260B	--	--	--	--	--	--	--	--	--	<0.0952	--	<0.0952	<0.0952	<0.0952	--	--	--
AGP-35-18.5	5/15/2006	18.5	8260B	--	--	--	--	--	--	--	--	--	<0.0953	--	<0.0953	<0.0953	<0.0953	--	--	--
AGP-36-18	5/16/2006	18	8260B	--	--	--	--	--	--	--	--	--	<0.0933	--	<0.0933	<0.0933	<0.0933	--	--	--
AGP-38-24	5/11/2006	24	8260B	--	--	--	--	--	--	--	--	--	<0.109	--	<0.109	<0.109	<0.109	--	--	--
AGP-39-17.5	5/16/2006	17.5	8260B	--	--	--	--	--	--	--	--	--	<0.0964	--	<0.0964	<0.0964	<0.0964	--	--	--
AGP-42-17	6/19/2006	17	8260B	--	--	--	--	--	--	--	--	--	<0.0988	--	<0.0988	<0.0988	<0.0988	--	--	--
AGP-43-16.5	6/15/2006	16.5	8260B	--	--	--	--	--	--	--	--	--	<0.106	--	<0.106	<0.106	<0.106	--	--	--
AGP-45-7	6/23/2006	7	8260B	--	--	--	--	--	--	--	--	--	<0.0994	--	<0.0994	<0.0994	<0.0994	--	--	--
AGP-01-47.5	5/10/2006	47.5	8260B	--	--	--	--	--	--	--	--	--	<0.0906	--	<0.0906	<0.0906	<0.0906	--	--	--
AGP-02-43	5/11/2006	43	8260B	--	--	--	--	--	--	--	--	--	<0.116	--	<0.116	<0.116	<0.116	--	--	--
AGP-03-41.5	5/10/2006	41.5	8260B	--	--	--	--	--	--	--	--	--	<0.135	--	<0.135	<0.135	<0.135	--	--	--
AGP-04-38	5/5/2006	38	8260B	--	--	--	--	--	--	--	--	--	<0.109	--	<0.109	0.135	<0.109	--	--	--
AGP-05-34	5/5/2006	34	8260B	--	--	--	--	--	--	--	--	--	<0.094	--	<0.094	0.496	<0.094	--	--	--
AGP-06-48	5/2/2006	48	8260B	--	--	--	--	--	--	--	--	--	<0.108	--	<0.108	0.23	<0.108	--	--	--
AGP-13-37.5	5/1/2006	37.5	8260B	--	--	--	--	--	--	--	--	--	0.602	--	0.347	22.4	<0.142	--	--	--
AGP-14-49	4/27/2006	49	8260B	--	--	--	--	--	--	--	--	--	<0.0846	--	<0.0846	1.99	<0.0846	--	--	--
AGP-15-42.5	4/26/2006	42.5	8260B	--	--	--	--	--	--	--	--	--	<0.186	--	0.0972	7.4	<0.178	--	--	--
AGP-16-37	4/27/2006	37	8260B	--	--	--	--	--	--	--	--	--	<0.1	--	<0.1	0.294	<0.1	--	--	--
AGP-17-39	4/28/2006	39	8260B	--	--	--	--	--	--	--	--	--	0.732	--	1.25	46	<0.728	--	--	--
AGP-18-37.5	4/28/2006	37.5	8260B	--	--	--	--	--	--	--	--	--	0.276	--	0.106	8.85	<0.183	--	--	--
AGP-19-42.5	4/28/2006	42.5	8260B	--	--	--	--	--	--	--	--	--	<0.184	--	<0.184	5.36	1.84	--	--	--
AGP-20-43	5/1/2006	43	8260B	--	--	--	--	--	--	--	--	--	<0.108	--	<0.108	3.03	<0.108	--	--	--
AGP-21-32.5	5/1/2006	32.5	8260B	--	--	--	--	--	--	--	--	--	<0.093	--	<0.093	<0.093	<0.093	--	--	--

Please refer to notes at end of table.

Table C-3
Historical Soil Analytical Tables - VOCs
NuStar Terminals Services, Inc. Vancouver Facility

Sample ID	Collection Date	Sample Depth (feet)	Method	Parameter in mg/Kg (ppm)																
				cis-1,3-Dichloropropene	trans-1,3-Dichloropropene	2,2-Dichloropropane	Di-Isopropyl ether	Ethylbenzene	Hexachloro-butadiene	Isopropylbenzene	p-Isopropyltoluene	2-Butanone (MEK)	Methylene Chloride	4-Methyl-2-pentanone (MIBK)	Methyl tert-butyl ether	Naphthalene	n-Propylbenzene	Styrene	1,1,1,2-Tetrachloroethane	1,1,2,2-Tetrachloroethane
AGP-03-13	5/10/2006	13	8260B	--	--	--	--	--	--	--	--	--	--	--	--	--	--	--	--	
AGP-10-6.5	4/25/2006	6.5	8260B	<0.359	<0.359	--	--	--	--	--	--	--	<3.590	--	--	--	--	--	<0.359	<0.359
AGP-12-13	4/25/2006	13	8260B	--	--	--	--	--	--	--	--	--	--	--	--	--	--	--	--	--
AGP-07-46.5	4/25/2006	46.5	8260B	<0.0967	<0.0967	--	--	--	--	--	--	--	<0.967	--	--	--	--	--	<0.0967	<0.0967
AGP-08-37.5	4/24/2006	37.5	8260B	<0.0918	<0.0918	--	--	--	--	--	--	--	<0.918	--	--	--	--	--	<0.0918	<0.0918
AGP-09-48.5	4/25/2006	48.5	8260B	<0.0910	<0.0910	--	--	--	--	--	--	--	<0.910	--	--	--	--	--	<0.0910	<0.0910
AGP-10-49.5	4/26/2006	49.5	8260B	<0.0903	<0.0903	--	--	--	--	--	--	--	<0.903	--	--	--	--	--	<0.0903	<0.0903
AGP-11-33	4/26/2006	33	8260B	<0.0904	<0.0904	--	--	--	--	--	--	--	<0.904	--	--	--	--	--	--	--
AGP-12-34.5	4/25/2006	34.5	8260B	--	--	--	--	--	--	--	--	--	--	--	--	--	--	--	--	--
AGP-12-37.5	4/25/2006	37.5	8260B	<0.657	<0.657	--	--	--	--	--	--	--	<6.570	--	--	--	--	--	<0.657	<0.657
AGP-12-48	4/25/2006	48	8260B	--	--	--	--	--	--	--	--	--	--	--	--	--	--	--	--	--
AGP-20-17.5	4/28/2005	17.5	8260B	--	--	--	--	--	--	--	--	--	--	--	--	--	--	--	--	--
AGP-21-13	5/1/2006	13	8260B	--	--	--	--	--	--	--	--	--	--	--	--	--	--	--	--	--
AGP-22-18	5/2/2006	18	8260B	--	--	--	--	--	--	--	--	--	--	--	--	--	--	--	--	--
AGP-23-12.5	5/8/2006	12.5	8260B	--	--	--	--	--	--	--	--	--	--	--	--	--	--	--	--	--
AGP-24-12	5/8/2006	12	8260B	--	--	--	--	--	--	--	--	--	--	--	--	--	--	--	--	--
AGP-26-18	5/3/2006	18	8260B	--	--	--	--	--	--	--	--	--	--	--	--	--	--	--	--	--
AGP-27-8.75	5/2/2006	8.75	8260B	--	--	--	--	--	--	--	--	--	--	--	--	--	--	--	--	--
AGP-28-9	5/3/2006	9	8260B	--	--	--	--	--	--	--	--	--	--	--	--	--	--	--	--	--
AGP-28-17.5	5/3/2006	17.5	8260B	--	--	--	--	--	--	--	--	--	--	--	--	--	--	--	--	--
AGP-29-9.5	5/4/2006	9.5	8260B	--	--	--	--	--	--	--	--	--	--	--	--	--	--	--	--	--
AGP-29-18	5/4/2006	18	8260B	--	--	--	--	--	--	--	--	--	--	--	--	--	--	--	--	--
AGP-32-14	5/9/2006	14	8260B	--	--	--	--	--	--	--	--	--	--	--	--	--	--	--	--	--
AGP-33-14	5/12/2006	14	8260B	--	--	--	--	--	--	--	--	--	--	--	--	--	--	--	--	--
AGP-35-18.5	5/15/2006	18.5	8260B	--	--	--	--	--	--	--	--	--	--	--	--	--	--	--	--	--
AGP-36-18	5/16/2006	18	8260B	--	--	--	--	--	--	--	--	--	--	--	--	--	--	--	--	--
AGP-38-24	5/11/2006	24	8260B	--	--	--	--	--	--	--	--	--	--	--	--	--	--	--	--	--
AGP-39-17.5	5/16/2006	17.5	8260B	--	--	--	--	--	--	--	--	--	--	--	--	--	--	--	--	--
AGP-42-17	6/19/2006	17	8260B	--	--	--	--	--	--	--	--	--	--	--	--	--	--	--	--	--
AGP-43-16.5	6/15/2006	16.5	8260B	--	--	--	--	--	--	--	--	--	--	--	--	--	--	--	--	--
AGP-45-7	6/23/2006	7	8260B	--	--	--	--	--	--	--	--	--	--	--	--	--	--	--	--	--
AGP-01-47.5	5/10/2006	47.5	8260B	--	--	--	--	--	--	--	--	--	--	--	--	--	--	--	--	--
AGP-02-43	5/11/2006	43	8260B	--	--	--	--	--	--	--	--	--	--	--	--	--	--	--	--	--
AGP-03-41.5	5/10/2006	41.5	8260B	--	--	--	--	--	--	--	--	--	--	--	--	--	--	--	--	--
AGP-04-38	5/5/2006	38	8260B	--	--	--	--	--	--	--	--	--	--	--	--	--	--	--	--	--
AGP-05-34	5/5/2006	34	8260B	--	--	--	--	--	--	--	--	--	--	--	--	--	--	--	--	--
AGP-06-48	5/2/2006	48	8260B	--	--	--	--	--	--	--	--	--	--	--	--	--	--	--	--	--
AGP-13-37.5	5/1/2006	37.5	8260B	--	--	--	--	--	--	--	--	--	--	--	--	--	--	--	--	--
AGP-14-49	4/27/2006	49	8260B	--	--	--	--	--	--	--	--	--	--	--	--	--	--	--	--	--
AGP-15-42.5	4/26/2006	42.5	8260B	--	--	--	--	--	--	--	--	--	--	--	--	--	--	--	--	--
AGP-16-37	4/27/2006	37	8260B	--	--	--	--	--	--	--	--	--	--	--	--	--	--	--	--	--
AGP-17-39	4/28/2006	39	8260B	--	--	--	--	--	--	--	--	--	--	--	--	--	--	--	--	--
AGP-18-37.5	4/28/2006	37.5	8260B	--	--	--	--	--	--	--	--	--	--	--	--	--	--	--	--	--
AGP-19-42.5	4/28/2006	42.5	8260B	--	--	--	--	--	--	--	--	--	--	--	--	--	--	--	--	--
AGP-20-43	5/1/2006	43	8260B	--	--	--	--	--	--	--	--	--	--	--	--	--	--	--	--	--
AGP-21-32.5	5/1/2006	32.5	8260B	--	--	--	--	--	--	--	--	--	--	--	--	--	--	--	--	--

Please refer to notes at end of table.

Table C-3
Historical Soil Analytical Tables - VOCs
NuStar Terminals Services, Inc. Vancouver Facility

Sample ID	Collection Date	Sample Depth (feet)	Method	Parameter in mg/Kg (ppm)														Vinyl chloride	Xylenes, Total
				1,1,2-Trichloro-1,2,2-trifluoroethane	Tetrachloro-ethene	Toluene	1,2,3-Trichlorobenzene	1,2,4-Trichlorobenzene	1,1,1-Trichloroethane	1,1,2-Trichloroethane	Trichloroethene	Trichlorofluoro-methane	1,2,3-Trichloropropane	1,2,4-Trimethylbenzene	1,2,3-Trimethylbenzene	1,3,5-Trimethylbenzene			
AGP-03-13	5/10/2006	13	8260B	--	<0.0956	--	--	--	<0.0956	--	<0.0956	--	<0.0956	--	--	--	--	<0.956	--
AGP-10-6.5	4/25/2006	6.5	8260B	--	3.14	--	--	--	<0.359	--	<0.359	<0.718	--	--	--	--	--	<3.59	--
AGP-12-13	4/25/2006	13	8260B	--	2.99	--	--	--	<0.0783	--	0.568	--	--	--	--	--	--	<0.783	--
AGP-07-46.5	4/25/2006	46.5	8260B	--	11.9	--	--	--	<0.0967	--	2.06	<0.193	--	--	--	--	--	<0.967	--
AGP-08-37.5	4/24/2006	37.5	8260B	--	0.18	--	--	--	<0.0918	--	0.937	<0.184	--	--	--	--	--	<0.918	--
AGP-09-48.5	4/25/2006	48.5	8260B	--	12.4	--	--	--	<0.091	--	2.35	<0.182	--	--	--	--	--	<0.91	--
AGP-10-49.5	4/26/2006	49.5	8260B	--	6.41	--	--	--	<0.0903	--	1.62	<0.181	--	--	--	--	--	<0.903	--
AGP-11-33	4/26/2006	33	8260B	--	0.958	--	--	--	<0.0904	--	0.219	<0.181	--	--	--	--	--	<0.904	--
AGP-12-34.5	4/25/2006	34.5	8260B	--	4.170 J	--	--	--	<0.148	--	1.310J	--	--	--	--	--	--	<1.48	--
AGP-12-37.5	4/25/2006	37.5	8260B	--	<0.657	--	--	--	<0.657	--	7.82	<0.001	--	--	--	--	--	25.1	--
AGP-12-48	4/25/2006	48	8260B	--	0.508	--	--	--	<0.0814	--	0.875	--	--	--	--	--	--	<0.814	--
AGP-20-17.5	4/28/2005	17.5	8260B	--	0.544	--	--	--	<0.107	--	<0.107	--	--	--	--	--	--	<1.07	--
AGP-21-13	5/1/2006	13	8260B	--	0.0995	--	--	--	<0.0939	--	<0.0939	--	--	--	--	--	--	<0.939	--
AGP-22-18	5/2/2006	18	8260B	--	41.7	--	--	--	<0.184	--	2.18	--	--	--	--	--	--	<1.84	--
AGP-23-12.5	5/8/2006	12.5	8260B	--	0.483	--	--	--	<0.103	--	<0.103	--	--	--	--	--	--	<1.03	--
AGP-24-12	5/8/2006	12	8260B	--	1.93	--	--	--	<0.0961	--	0.144	--	--	--	--	--	--	<0.961	--
AGP-26-18	5/3/2006	18	8260B	--	4.03	--	--	--	<0.115	--	0.182	--	--	--	--	--	--	<1.15	--
AGP-27-8.75	5/2/2006	8.75	8260B	--	1.51	--	--	--	<0.0896	--	<0.0896	--	--	--	--	--	--	<0.896	--
AGP-28-9	5/3/2006	9	8260B	--	59.3	--	--	--	<0.218	--	0.536	--	--	--	--	--	--	<2.18	--
AGP-28-17.5	5/3/2006	17.5	8260B	--	65.2	--	--	--	<0.403	--	1.87	--	--	--	--	--	--	<4.03	--
AGP-29-9.5	5/4/2006	9.5	8260B	--	1.320	--	--	--	<4.78	--	<4.78	--	--	--	--	--	--	<47.8	--
AGP-29-18	5/4/2006	18	8260B	--	14.9	--	--	--	<0.093	--	<0.093	--	--	--	--	--	--	<0.93	--
AGP-32-14	5/9/2006	14	8260B	--	<0.0984	--	--	--	<0.0984	--	<0.0984	--	--	--	--	--	--	<0.984	--
AGP-33-14	5/12/2006	14	8260B	--	<0.0952	--	--	--	<0.0952	--	<0.0952	--	--	--	--	--	--	<0.952	--
AGP-35-18.5	5/15/2006	18.5	8260B	--	<0.0953	--	--	--	<0.0953	--	<0.0953	--	--	--	--	--	--	<0.953	--
AGP-36-18	5/16/2006	18	8260B	--	<0.0933	--	--	--	<0.0933	--	<0.0933	--	--	--	--	--	--	<0.933	--
AGP-38-24	5/11/2006	24	8260B	--	0.204	--	--	--	<0.109	--	<0.109	--	--	--	--	--	--	<1.09	--
AGP-39-17.5	5/16/2006	17.5	8260B	--	<0.0964	--	--	--	<0.0964	--	<0.0964	--	--	--	--	--	--	<0.964	--
AGP-42-17	6/19/2006	17	8260B	--	<0.0988	--	--	--	<0.0988	--	<0.0988	--	--	--	--	--	--	<0.988	--
AGP-43-16.5	6/15/2006	16.5	8260B	--	<0.106	--	--	--	<0.106	--	<0.106	--	--	--	--	--	--	<1.06	--
AGP-45-7	6/23/2006	7	8260B	--	<0.0994	--	--	--	<0.0994	--	<0.0994	--	--	--	--	--	--	<0.994	--
AGP-01-47.5	5/10/2006	47.5	8260B	--	<0.0906	--	--	--	<0.0906	--	<0.0906	--	--	--	--	--	--	<0.906	--
AGP-02-43	5/11/2006	43	8260B	--	<0.116	--	--	--	<0.116	--	<0.116	--	--	--	--	--	--	<1.16	--
AGP-03-41.5	5/10/2006	41.5	8260B	--	<0.135	--	--	--	<0.135	--	<0.135	--	--	--	--	--	--	<1.35	--
AGP-04-38	5/5/2006	38	8260B	--	<0.109	--	--	--	<0.109	--	<0.109	--	--	--	--	--	--	<1.09	--
AGP-05-34	5/5/2006	34	8260B	--	0.141	--	--	--	<0.094	--	0.103	--	--	--	--	--	--	<0.94	--
AGP-06-48	5/2/2006	48	8260B	--	6.05	--	--	--	<0.108	--	0.821	--	--	--	--	--	--	<1.08	--
AGP-13-37.5	5/1/2006	37.5	8260B	--	0.158	--	--	--	<0.0987	--	1.38	--	--	--	--	--	--	<0.987	--
AGP-14-49	4/27/2006	49	8260B	--	<0.0846	--	--	--	<0.0846	--	<0.0846	--	--	--	--	--	--	<0.846	--
AGP-15-42.5	4/26/2006	42.5	8260B	--	5.77	--	--	--	<0.0631	--	2.22	--	--	--	--	--	--	<0.631	--
AGP-16-37	4/27/2006	37	8260B	--	16.2	--	--	--	<0.1	--	4.15	--	--	--	--	--	--	<1	--
AGP-17-39	4/28/2006	39	8260B	--	68	--	--	--	<0.201	--	61.2	--	--	--	--	--	--	<2.01	--
AGP-18-37.5	4/28/2006	37.5	8260B	--	22.8	--	--	--	<0.104	--	11.1	--	--	--	--	--	--	<1.04	--
AGP-19-42.5	4/28/2006	42.5	8260B	--	61.3	--	--	--	<0.184	--	27.3	--	--	--	--	--	--	<1.84	--
AGP-20-43	5/1/2006	43	8260B	--	3.52	--	--	--	<0.108	--	2.69	--	--	--	--	--	--	<1.08	--
AGP-21-32.5	5/1/2006	32.5	8260B	--	0.837	--	--	--	<0.093	--	0.113	--	--	--	--	--	--	<0.93	--

Please refer to notes at end of table.

Table C-3
 Historical Soil Analytical Tables - VOCs
 NuStar Terminals Services, Inc. Vancouver Facility

Sample ID	Collection Date	Sample Depth (feet)	Method	Parameter in mg/Kg (ppm)															
				Acetone	Acrylonitrile	Benzene	Bromobenzene	Bromodichloro-methane	Bromoform	Bromomethane	n-Butylbenzene	sec-Butylbenzene	tert-Butylbenzene	Carbon tetrachloride	Chlorobenzene	Chlorodibromo-methane	Chloroethane	2-Chloroethyl vinyl ether	Chloroform
AGP-21-39	5/1/2006	39	8260B	--	--	--	--	--	--	--	--	--	--	--	--	--	--	--	--
AGP-21-48	5/1/2006	48	8260B	--	--	--	--	--	--	--	--	--	--	--	--	--	--	--	--
AGP-22-38.5	5/2/2006	38.5	8260B	--	--	--	--	--	--	--	--	--	--	--	--	--	--	--	--
AGP-23-47.5	5/9/2006	47.5	8260B	--	--	--	--	--	--	--	--	--	--	--	--	--	--	--	--
AGP-24-37.5	5/8/2006	37.5	8260B	--	--	--	--	--	--	--	--	--	--	--	--	--	--	--	--
AGP-25-42	5/4/2006	42	8260B	--	--	--	--	--	--	--	--	--	--	--	--	--	--	--	--
AGP-26-32.5	5/3/2006	32.5	8260B	--	--	--	--	--	--	--	--	--	--	--	--	--	--	--	--
AGP-27-28	5/2/2006	28	8260B	--	--	--	--	--	--	--	--	--	--	--	--	--	--	--	--
AGP-28-37.5	5/3/2006	37.5	8260B	--	--	--	--	--	--	--	--	--	--	--	--	--	--	--	--
AGP-29-28	5/4/2006	28	8260B	--	--	--	--	--	--	--	--	--	--	--	--	--	--	--	--
AGP-29-42	5/4/2006	42	8260B	--	--	--	--	--	--	--	--	--	--	--	--	--	--	--	--
AGP-30-29	5/9/2006	29	8260B	--	--	--	--	--	--	--	--	--	--	--	--	--	--	--	--
AGP-31-27.5	5/8/2006	27.5	8260B	--	--	--	--	--	--	--	--	--	--	--	--	--	--	--	--
AGP-31-42.5	5/8/2006	42.5	8260B	--	--	--	--	--	--	--	--	--	--	--	--	--	--	--	--
AGP-32-31.5	5/9/2006	31.5	8260B	--	--	--	--	--	--	--	--	--	--	--	--	--	--	--	--
AGP-33-49	5/12/2006	49	8260B	--	--	--	--	--	--	--	--	--	--	--	--	--	--	--	--
AGP-34-27	5/15/2006	27	8260B	--	--	--	--	--	--	--	--	--	--	--	--	--	--	--	--
AGP-34-42.5	5/15/2006	42.5	8260B	--	--	--	--	--	--	--	--	--	--	--	--	--	--	--	--
AGP-35-37.5	5/15/2006	37.5	8260B	--	--	--	--	--	--	--	--	--	--	--	--	--	--	--	--
AGP-37-28	5/11/2006	28	8260B	--	--	--	--	--	--	--	--	--	--	--	--	--	--	--	--
AGP-37-38	5/12/2006	38	8260B	--	--	--	--	--	--	--	--	--	--	--	--	--	--	--	--
AGP-38-46	5/11/2006	46	8260B	--	--	--	--	--	--	--	--	--	--	--	--	--	--	--	--
AGP-39-47.5	5/16/2006	47.5	8260B	--	--	--	--	--	--	--	--	--	--	--	--	--	--	--	--
AGP-44-45.5	6/23/2006	45.5	8260B	--	--	--	--	--	--	--	--	--	--	--	--	--	--	--	--
AGP-44-51.5	6/23/2006	51.5	8260B	--	--	--	--	--	--	--	--	--	--	--	--	--	--	--	--
AGP-52-4	6/13/2007	15.5-16	8260B	--	--	<0.0456	--	--	--	--	--	--	--	--	--	<0.228	--	<0.228	--
AGP-54-5	6/15/2007	20.5-21	8260B	--	--	<0.0457	--	--	--	--	--	--	--	--	--	<0.228	--	<0.228	--
AGP-55-6	6/19/2007	20.5-21	8260B	--	--	<0.0445	--	--	--	--	--	--	--	--	--	<0.223	--	<0.223	--
AGP-56-6	6/19/2007	17.5-18	8260B	--	--	<0.0418	--	--	--	--	--	--	--	--	--	<0.209	--	<0.209	--
AGP-57-4	6/19/2007	16-16.5	8260B	--	--	<0.0432	--	--	--	--	--	--	--	--	--	<0.216	--	<0.216	--
AGP-57-4 DUP	6/19/2007	16-16.5	8260B	--	--	<0.0433	--	--	--	--	--	--	--	--	--	<0.217	--	<0.217	--

Please refer to notes at end of table.

Table C-3
Historical Soil Analytical Tables - VOCs
NuStar Terminals Services, Inc. Vancouver Facility

Sample ID	Collection Date	Sample Depth (feet)	Method	Parameter in mg/Kg (ppm)																	
				2-Chlorotoluene	4-Chlorotoluene	1,2-Dibromo-3-Chloropropane	1,2-Dibromoethane	Dibromomethane	1,2-Dichlorobenzene	1,3-Dichlorobenzene	1,4-Dichlorobenzene	Dichlorodifluoro-methane	1,1-Dichloroethane	1,2-Dichloroethane	1,1-Dichloroethene	cis-1,2-Dichloroethene	trans-1,2-Dichloroethene	1,2-Dichloropropane	1,1-Dichloropropene	1,3-Dichloropropane	
AGP-21-39	5/1/2006	39	8260B	--	--	--	--	--	--	--	--	--	--	<0.419	--	<0.419	<0.419	<0.419	--	--	--
AGP-21-48	5/1/2006	48	8260B	--	--	--	--	--	--	--	--	--	--	<0.0884	--	<0.0884	0.76	<0.0884	--	--	--
AGP-22-38.5	5/2/2006	38.5	8260B	--	--	--	--	--	--	--	--	--	--	<0.109	--	<0.109	0.261	<0.109	--	--	--
AGP-23-47.5	5/9/2006	47.5	8260B	--	--	--	--	--	--	--	--	--	--	0.19	--	0.0977	3.71	<0.0939	--	--	--
AGP-24-37.5	5/8/2006	37.5	8260B	--	--	--	--	--	--	--	--	--	--	<0.0905	--	<0.0905	0.431	<0.0905	--	--	--
AGP-25-42	5/4/2006	42	8260B	--	--	--	--	--	--	--	--	--	--	<0.0858	--	<0.0858	0.721	<0.0858	--	--	--
AGP-26-32.5	5/3/2006	32.5	8260B	--	--	--	--	--	--	--	--	--	--	<0.128	--	<0.128	<0.128	<0.128	--	--	--
AGP-27-28	5/2/2006	28	8260B	--	--	--	--	--	--	--	--	--	--	<0.124	--	<0.124	<0.124	<0.124	--	--	--
AGP-28-37.5	5/3/2006	37.5	8260B	--	--	--	--	--	--	--	--	--	--	<0.0964	--	<0.0964	<0.0964	<0.0964	--	--	--
AGP-29-28	5/4/2006	28	8260B	--	--	--	--	--	--	--	--	--	--	<0.102	--	<0.102	<0.102	<0.102	--	--	--
AGP-29-42	5/4/2006	42	8260B	--	--	--	--	--	--	--	--	--	--	<0.0951	--	<0.0951	0.198	<0.0951	--	--	--
AGP-30-29	5/9/2006	29	8260B	--	--	--	--	--	--	--	--	--	--	<0.0925	--	<0.0925	0.242	<0.0925	--	--	--
AGP-31-27.5	5/8/2006	27.5	8260B	--	--	--	--	--	--	--	--	--	--	<0.0923	--	<0.0923	0.233	<0.0923	--	--	--
AGP-31-42.5	5/8/2006	42.5	8260B	--	--	--	--	--	--	--	--	--	--	<0.0801	--	<0.0801	<0.0801	<0.0801	--	--	--
AGP-32-31.5	5/9/2006	31.5	8260B	--	--	--	--	--	--	--	--	--	--	<0.0969	--	<0.0969	1.66	<0.0969	--	--	--
AGP-33-49	5/12/2006	49	8260B	--	--	--	--	--	--	--	--	--	--	<0.0875	--	<0.0875	<0.0875	<0.0875	--	--	--
AGP-34-27	5/15/2006	27	8260B	--	--	--	--	--	--	--	--	--	--	<0.0958	--	<0.0958	<0.0958	<0.0958	--	--	--
AGP-34-42.5	5/15/2006	42.5	8260B	--	--	--	--	--	--	--	--	--	--	<0.0972	--	<0.0972	0.334	<0.0972	--	--	--
AGP-35-37.5	5/15/2006	37.5	8260B	--	--	--	--	--	--	--	--	--	--	<0.0923	--	<0.0923	<0.0923	<0.0923	--	--	--
AGP-37-28	5/11/2006	28	8260B	--	--	--	--	--	--	--	--	--	--	<0.132	--	<0.132	1.42	<0.132	--	--	--
AGP-37-38	5/12/2006	38	8260B	--	--	--	--	--	--	--	--	--	--	<0.105	--	<0.105	2.81	<0.105	--	--	--
AGP-38-46	5/11/2006	46	8260B	--	--	--	--	--	--	--	--	--	--	<0.474	--	<0.474	2.38	<0.474	--	--	--
AGP-39-47.5	5/16/2006	47.5	8260B	--	--	--	--	--	--	--	--	--	--	<0.0736	--	<0.0736	0.713	<0.0736	--	--	--
AGP-44-45.5	6/23/2006	45.5	8260B	--	--	--	--	--	--	--	--	--	--	<0.0913	--	<0.0913	0.46	<0.0913	--	--	--
AGP-44-51.5	6/23/2006	51.5	8260B	--	--	--	--	--	--	--	--	--	--	<0.0792	--	<0.0792	<0.0792	<0.0792	--	--	--
AGP-52-4	6/13/2007	15.5-16	8260B	--	--	--	--	--	--	--	--	--	--	<0.228	<0.228	<0.228	<0.228	<0.228	--	--	--
AGP-54-5	6/15/2007	20.5-21	8260B	--	--	--	--	--	--	--	--	--	--	<0.228	<0.228	<0.228	<0.228	<0.228	--	--	--
AGP-55-6	6/19/2007	20.5-21	8260B	--	--	--	--	--	--	--	--	--	--	<0.223	<0.223	<0.223	<0.223	<0.223	--	--	--
AGP-56-6	6/19/2007	17.5-18	8260B	--	--	--	--	--	--	--	--	--	--	<0.209	<0.209	<0.209	<0.209	<0.209	--	--	--
AGP-57-4	6/19/2007	16-16.5	8260B	--	--	--	--	--	--	--	--	--	--	<0.216	<0.216	<0.216	<0.216	<0.216	--	--	--
AGP-57-4 DUP	6/19/2007	16-16.5	8260B	--	--	--	--	--	--	--	--	--	--	<0.217	<0.217	<0.217	<0.217	<0.217	--	--	--

Please refer to notes at end of table.

Table C-3
Historical Soil Analytical Tables - VOCs
NuStar Terminals Services, Inc. Vancouver Facility

Sample ID	Collection Date	Sample Depth (feet)	Method	Parameter inmg/Kg (ppm)															
				cis-1,3-Dichloropropene	trans-1,3-Dichloropropene	2,2-Dichloropropane	Di-Isopropyl ether	Ethylbenzene	Hexachloro-butadiene	Isopropylbenzene	p-Isopropyltoluene	2-Butanone (MEK)	Methylene Chloride	4-Methyl-2-pentanone (MIBK)	Methyl tert-butyl ether	Naphthalene	n-Propylbenzene	Styrene	1,1,1,2-Tetrachloroethane
AGP-21-39	5/1/2006	39	8260B	--	--	--	--	--	--	--	--	--	--	--	--	--	--	--	--
AGP-21-48	5/1/2006	48	8260B	--	--	--	--	--	--	--	--	--	--	--	--	--	--	--	--
AGP-22-38.5	5/2/2006	38.5	8260B	--	--	--	--	--	--	--	--	--	--	--	--	--	--	--	--
AGP-23-47.5	5/9/2006	47.5	8260B	--	--	--	--	--	--	--	--	--	--	--	--	--	--	--	--
AGP-24-37.5	5/8/2006	37.5	8260B	--	--	--	--	--	--	--	--	--	--	--	--	--	--	--	--
AGP-25-42	5/4/2006	42	8260B	--	--	--	--	--	--	--	--	--	--	--	--	--	--	--	--
AGP-26-32.5	5/3/2006	32.5	8260B	--	--	--	--	--	--	--	--	--	--	--	--	--	--	--	--
AGP-27-28	5/2/2006	28	8260B	--	--	--	--	--	--	--	--	--	--	--	--	--	--	--	--
AGP-28-37.5	5/3/2006	37.5	8260B	--	--	--	--	--	--	--	--	--	--	--	--	--	--	--	--
AGP-29-28	5/4/2006	28	8260B	--	--	--	--	--	--	--	--	--	--	--	--	--	--	--	--
AGP-29-42	5/4/2006	42	8260B	--	--	--	--	--	--	--	--	--	--	--	--	--	--	--	--
AGP-30-29	5/9/2006	29	8260B	--	--	--	--	--	--	--	--	--	--	--	--	--	--	--	--
AGP-31-27.5	5/8/2006	27.5	8260B	--	--	--	--	--	--	--	--	--	--	--	--	--	--	--	--
AGP-31-42.5	5/8/2006	42.5	8260B	--	--	--	--	--	--	--	--	--	--	--	--	--	--	--	--
AGP-32-31.5	5/9/2006	31.5	8260B	--	--	--	--	--	--	--	--	--	--	--	--	--	--	--	--
AGP-33-49	5/12/2006	49	8260B	--	--	--	--	--	--	--	--	--	--	--	--	--	--	--	--
AGP-34-27	5/15/2006	27	8260B	--	--	--	--	--	--	--	--	--	--	--	--	--	--	--	--
AGP-34-42.5	5/15/2006	42.5	8260B	--	--	--	--	--	--	--	--	--	--	--	--	--	--	--	--
AGP-35-37.5	5/15/2006	37.5	8260B	--	--	--	--	--	--	--	--	--	--	--	--	--	--	--	--
AGP-37-28	5/11/2006	28	8260B	--	--	--	--	--	--	--	--	--	--	--	--	--	--	--	--
AGP-37-38	5/12/2006	38	8260B	--	--	--	--	--	--	--	--	--	--	--	--	--	--	--	--
AGP-38-46	5/11/2006	46	8260B	--	--	--	--	--	--	--	--	--	--	--	--	--	--	--	--
AGP-39-47.5	5/16/2006	47.5	8260B	--	--	--	--	--	--	--	--	--	--	--	--	--	--	--	--
AGP-44-45.5	6/23/2006	45.5	8260B	--	--	--	--	--	--	--	--	--	--	--	--	--	--	--	--
AGP-44-51.5	6/23/2006	51.5	8260B	--	--	--	--	--	--	--	--	--	--	--	--	--	--	--	--
AGP-52-4	6/13/2007	15.5-16	8260B	--	--	--	--	--	--	--	--	<2.28	--	--	--	--	--	--	--
AGP-54-5	6/15/2007	20.5-21	8260B	--	--	--	--	--	--	--	--	<2.28	--	--	--	--	--	--	--
AGP-55-6	6/19/2007	20.5-21	8260B	--	--	--	--	--	--	--	--	<2.23	--	--	--	--	--	--	--
AGP-56-6	6/19/2007	17.5-18	8260B	--	--	--	--	--	--	--	--	<2.09	--	--	--	--	--	--	--
AGP-57-4	6/19/2007	16-16.5	8260B	--	--	--	--	--	--	--	--	<2.16	--	--	--	--	--	--	--
AGP-57-4 DUP	6/19/2007	16-16.5	8260B	--	--	--	--	--	--	--	--	<2.17	--	--	--	--	--	--	--

Please refer to notes at end of table.

Table C-3
Historical Soil Analytical Tables - VOCs
NuStar Terminals Services, Inc. Vancouver Facility

Sample ID	Collection Date	Sample Depth (feet)	Method	Parameter in mg/Kg (ppm)														
				1,1,2-Trichloro-1,2,2-trifluoroethane	Tetrachloro-ethene	Toluene	1,2,3-Trichlorobenzene	1,2,4-Trichlorobenzene	1,1,1-Trichloroethane	1,1,2-Trichloroethane	Trichloroethene	Trichlorofluoro-methane	1,2,3-Trichloropropane	1,2,4-Trimethylbenzene	1,2,3-Trimethylbenzene	1,3,5-Trimethylbenzene	Vinyl chloride	Xylenes, Total
AGP-21-39	5/1/2006	39	8260B	--	145	--	--	--	<0.419	--	4.29	--	--	--	--	--	<4.19	--
AGP-21-48	5/1/2006	48	8260B	--	<0.0884	--	--	--	<0.0884	--	0.11	--	--	--	--	--	<0.884	--
AGP-22-38.5	5/2/2006	38.5	8260B	--	26.4	--	--	--	0.476	--	4.09	--	--	--	--	--	<1.09	--
AGP-23-47.5	5/9/2006	47.5	8260B	--	0.192	--	--	--	<0.0939	--	1.95	--	--	--	--	--	<0.939	--
AGP-24-37.5	5/8/2006	37.5	8260B	--	34.8	--	--	--	<0.0905	--	4.43	--	--	--	--	--	<0.905	--
AGP-25-42	5/4/2006	42	8260B	--	2.43	--	--	--	<0.0858	--	0.829	--	--	--	--	--	<0.858	--
AGP-26-32.5	5/3/2006	32.5	8260B	--	0.434	--	--	--	<0.128	--	<0.128	--	--	--	--	--	<1.28	--
AGP-27-28	5/2/2006	28	8260B	--	0.712	--	--	--	<0.124	--	<0.124	--	--	--	--	--	<1.24	--
AGP-28-37.5	5/3/2006	37.5	8260B	--	0.262	--	--	--	<0.0964	--	<0.0964	--	--	--	--	--	<0.964	--
AGP-29-28	5/4/2006	28	8260B	--	0.821	--	--	--	<0.102	--	<0.102	--	--	--	--	--	<1.02	--
AGP-29-42	5/4/2006	42	8260B	--	4.14	--	--	--	<0.0951	--	1.33	--	--	--	--	--	<0.951	--
AGP-30-29	5/9/2006	29	8260B	--	<0.0925	--	--	--	<0.0925	--	<0.0925	--	--	--	--	--	<0.925	--
AGP-31-27.5	5/8/2006	27.5	8260B	--	1.040	--	--	--	<0.0923	--	<0.0923	--	--	--	--	--	<0.923	--
AGP-31-42.5	5/8/2006	42.5	8260B	--	<0.0801	--	--	--	<0.0801	--	<0.0801	--	--	--	--	--	<0.801	--
AGP-32-31.5	5/9/2006	31.5	8260B	--	<0.0969	--	--	--	<0.0969	--	<0.0969	--	--	--	--	--	1.06	--
AGP-33-49	5/12/2006	49	8260B	--	<0.0875	--	--	--	<0.0875	--	<0.0875	--	--	--	--	--	<0.875	--
AGP-34-27	5/15/2006	27	8260B	--	0.383	--	--	--	<0.0958	--	<0.0958	--	--	--	--	--	<0.958	--
AGP-34-42.5	5/15/2006	42.5	8260B	--	0.179	--	--	--	<0.0972	--	<0.0972	--	--	--	--	--	<0.972	--
AGP-35-37.5	5/15/2006	37.5	8260B	--	<0.0923	--	--	--	<0.0923	--	<0.0923	--	--	--	--	--	<0.923	--
AGP-37-28	5/11/2006	28	8260B	--	0.498	--	--	--	<0.132	--	<0.132	--	--	--	--	--	<1.32	--
AGP-37-38	5/12/2006	38	8260B	--	<0.105	--	--	--	<0.105	--	<0.105	--	--	--	--	--	<1.05	--
AGP-38-46	5/11/2006	46	8260B	--	101	--	--	--	<0.474	--	9.51	--	--	--	--	--	<4.74	--
AGP-39-47.5	5/16/2006	47.5	8260B	--	1.04	--	--	--	<0.0736	--	0.542	--	--	--	--	--	<0.736	--
AGP-44-45.5	6/23/2006	45.5	8260B	--	3.47	--	--	--	<0.0913	--	0.657	--	--	--	--	--	<0.913	--
AGP-44-51.5	6/23/2006	51.5	8260B	--	0.207	--	--	--	<0.0792	--	<0.0792	--	--	--	--	--	<0.792	--
AGP-52-4	6/13/2007	15.5-16	8260B	--	<0.228	<0.228	--	--	<0.228	--	<0.228	--	--	--	--	--	<0.228	--
AGP-54-5	6/15/2007	20.5-21	8260B	--	<0.228	<0.228	--	--	<0.228	--	<0.228	--	--	--	--	--	<0.228	--
AGP-55-6	6/19/2007	20.5-21	8260B	--	<0.223	<0.223	--	--	<0.223	--	<0.223	--	--	--	--	--	<0.223	--
AGP-56-6	6/19/2007	17.5-18	8260B	--	<0.209	<0.209	--	--	<0.209	--	<0.209	--	--	--	--	--	<0.209	--
AGP-57-4	6/19/2007	16-16.5	8260B	--	<0.216	<0.216	--	--	<0.216	--	<0.216	--	--	--	--	--	<0.216	--
AGP-57-4 DUP	6/19/2007	16-16.5	8260B	--	<0.217	<0.217	--	--	<0.217	--	<0.217	--	--	--	--	--	<0.217	--

- Notes:
1. Concentrations in micrograms per kilogram (mg/Kg) parts per billion (ppm).
 2. < = Not detected at corresponding numerical limit.
 3. **Bolded** values indicate analyte detected above laboratory method detection limits (MDLs).
 4. J = (EPA) - Estimated value below the lowest calibration point. Confidence correlates with concentration.
 5. -- = Compound not reported or sample not analyzed.

Table C-4
Historical Depth Discreet Groundwater Analytical Results
Remedial Investigation
NuStar Vancouver Terminal

Sample	Date Collected	Depth (Feet)	Analyte Concentration in µg/L (ppb)																					
			Benzene	Chloroethane	Chloroform	2-Butanone (MEK)	1,1-DCA	1,2-DCA	1,1-DCE	cis-1,2-DCE	trans-1,2-DCE	1,2-DCP	PCE	Toluene	1,1,1-TCA	TCE	Vinyl chloride							
AGP-01-35	5/10/2006	35	--	0.50	U	0.73	--	1.78	8.44	1.59	97.2	1.09	0.50	U	28.8	--	0.5	U	23.2	62.6				
AGP-01-45	5/10/2006	45	--	0.56	U	0.50	U	0.53	0.50	0.50	U	0.50	U	0.50	U	0.5	U	0.5	U	0.5	U			
AGP-02-35	5/11/2006	35	--	0.50	U	0.50	U	1.63	2.78	0.50	U	12.6	0.50	U	0.50	U	73.2	--	0.5	U	19.8	0.82	U	
AGP-02-45	5/11/2006	45	--	7.15	U	0.50	U	2.29	0.50	U	0.50	0.75	0.50	U	0.50	U	0.5	U	0.5	U	0.5	U	0.5	U
AGP-03-35	5/10/2006	35	--	0.80	U	0.85	--	6.37	33.6	0.50	U	85.2	1.91	0.93	33.5	--	1.77	U	16.1	1.83				
AGP-03-45	5/10/2006	45	--	21.2	U	0.69	--	1.91	1.58	0.50	U	9.59	0.50	U	0.50	U	33.5	--	0.97	U	10.7	0.5	U	
AGP-04-35	5/5/2006	35	--	0.71	U	2.19	--	10.0	5.07	0.58	U	183	3.40	2.61	78.6	--	7.13	U	90.5	2.30				
AGP-04-45	5/5/2006	45	--	41.6	U	4.30	--	28.7	7.10	1.00	U	231	4.60	3.58	18.8	--	3.90	U	10.3	7.26				
AGP-05-35	5/5/2006	35	--	0.50	U	0.50	U	9.12	0.50	U	0.50	U	26.3	0.50	U	1.98	--	0.5	U	1.88	13.5			
AGP-05-45	5/5/2006	45	--	12.6	U	0.50	U	0.50	U	0.50	U	0.50	U	0.50	U	0.5	U	0.5	U	0.5	U	0.5	U	
AGP-06-35	5/2/2006	35	--	5.00	U	5.00	U	29.1	5.00	U	10.2	910	10.5	5.00	U	1,490	--	17.2	U	519	5.20	U		
AGP-06-45	5/2/2006	45	--	50	U	50	U	58.0	50	U	50	U	1,390	50.0	U	50	U	9,710	--	90.0	3,160	50	U	
AGP-07-25	4/25/2006	25	--	5.00	U	5.00	U	7.80	5.00	U	5.00	U	105	5.00	U	5.00	U	1,380	--	21.7	398	16.5	U	
AGP-07-35	4/25/2006	35	--	25	U	25	U	102	25	U	43.0	1,350	25	U	25	U	3,520	--	73.5	1,450	108	U		
AGP-07-45	4/25/2006	45	--	25	U	25	U	132	25	U	71.0	994	25	U	25	U	9,820	--	248	4,080	25	U		
AGP-08-25	4/24/2006	25	--	2.50	U	2.50	U	2.50	U	2.50	U	19.4	2.5	U	2.50	U	470	--	11.2	277	2.5	U		
AGP-08-35	4/24/2006	35	--	25	U	25	U	61.0	25	U	29.5	928	25	U	25	U	3,920	--	63.0	1,380	76.5	U		
AGP-08-45	4/24/2006	45	--	25	U	25	U	104	25	U	57.0	1,290	25	U	25	U	6,800	--	142	2,980	25	U		
AGP-09-25	4/24/2006	25	--	0.50	U	0.50	U	0.53	0.50	U	0.50	U	0.68	0.50	U	0.50	U	55.1	--	5.31	59.7	0.5	U	
AGP-09-35	4/24/2006	35	--	5.00	U	5.00	U	5.00	U	5.00	U	61.9	5.00	U	5.00	U	1,200	--	9.50	201	5	U		
AGP-09-45	4/25/2006	45	--	25	U	25	U	159	25	U	85.5	2,610	27.0	25	U	5,850	--	206	3,010	25	U			
AGP-10-35	4/26/2006	35	--	2.50	U	2.50	U	7.80	2.50	U	3.70	161	2.50	U	2.50	U	841	--	8.05	186	15.4	U		
AGP-10-45	4/26/2006	45	--	50	U	50	U	540	50	U	130	10,600	57.0	50	U	3,280	--	102	2,410	587	U			
AGP-11-35	4/26/2006	35	--	10	U	10	U	12.0	10	U	10	U	160	10	U	2,380	--	25.2	511	28.4	U			
AGP-11-45	4/26/2006	45	--	102	U	25	U	462	25	U	126	8,100	51.5	25	U	2,400	--	155	2,660	400	U			
AGP-12-35	4/25/2006	35	--	25	U	25	U	99.5	25	U	51.0	1,320	25	U	25	U	5,440	--	95.5	1,920	38.0	U		
AGP-12-45	4/25/2006	45	--	50	U	50	U	728	50	U	162	15,500	214	50	U	1,480	--	159	1,980	231	U			
AGP-40-56	6/15/2006	56	--	1.00	U	1.00	U	16.3	1.00	U	5.64	314	6.00	1.00	U	201	--	3.12	138	1.44	U			
AGP-40-66	6/15/2006	66	--	1.00	U	1.00	U	11.3	1.00	U	3.64	211	2.08	1.00	U	176	--	4.24	115	1.56	U			
AGP-13-35	5/1/2006	35	--	25	U	25	U	25	U	25	U	246	25	U	25	U	3,950	--	81.5	745	25	U		
AGP-13-45	5/1/2006	45	--	7.55	U	2.50	U	121	2.50	U	15.8	974	5.85	2.50	U	198	--	11.2	331	77.8	U			
AGP-14-35	4/27/2006	35	--	25	U	25	U	25.5	25	U	25	U	142	25	U	4,920	--	81.5	950	25	U			
AGP-14-45	4/27/2006	45	--	10	U	10	U	201	10	U	28.4	2,750	10.4	10	U	54.2	--	10	U	101	198	U		
AGP-14-55	4/27/2006	55	--	2.50	U	2.50	U	15.2	2.50	U	4.80	401	3.35	2.50	U	46.3	--	2.5	U	30.8	5.35	U		
AGP-15-35	4/26/2006	35	--	25	U	25	U	25	U	25	U	104	25	U	25	U	6,200	--	62.0	1,300	25	U		
AGP-15-45	4/26/2006	45	--	10	U	10	U	194	10	U	39.2	3,690	10.0	10	U	10.4	--	10	U	10	U	380	U	
AGP-16-35	4/27/2006	35	--	10	U	10	U	20.8	10	U	15.2	132	10	U	10	U	3,610	--	57.2	768	10	U		
AGP-16-45	4/27/2006	45	--	25	U	25	U	444	25	U	94.5	9,510	86.0	25	U	28.5	--	25	U	30.0	57.5	U		

Please refer to notes at end of table.

Table C-4
Historical Depth Discreet Groundwater Analytical Results
Remedial Investigation
NuStar Vancouver Terminal

Sample	Date Collected	Depth (Feet)	Analyte Concentration in µg/L (ppb)																								
			Benzene	Chloroethane		Chloroform		2-Butanone (MEK)		1,1-DCA		1,2-DCA		1,1-DCE		cis-1,2-DCE		trans-1,2-DCE		1,2-DCP		PCE	Toluene	1,1,1-TCA		TCE	Vinyl chloride
AGP-17-35	4/28/2006	35	--	10	U	10	U	--	13.0	10	U	10	U	148	10	U	10	U	2,550	--	--	10	U	464	10	U	
AGP-17-45	4/28/2006	45	--	25	U	25	U	--	378	25	U	62.0	8,910	62.5	25	U	78.5	--	--	25	U	408	107	U			
AGP-18-35	4/28/2006	35	--	10	U	10	U	--	17.8	10	U	10	U	208	10	U	10	U	2,630	--	--	11.0	U	725	10	U	
AGP-18-45	4/28/2006	45	--	13.6	U	5.00	U	--	105	5.00	U	8.00	1,310	5.00	U	5.00	U	35.4	--	--	5	U	46.3	17.4	U		
AGP-19-35	4/28/2006	35	--	25	U	25	U	--	32.5	25	U	25	U	542	25	U	25	U	3,550	--	--	25	U	920	25	U	
AGP-19-45	4/28/2006	45	--	50	U	50	U	--	702	50	U	96.0	13,600	348	50	U	56.0	--	--	50	U	259	206	U			
AGP-20-35	5/1/2006	35	--	10	U	10	U	--	10	U	10	U	37.0	10	U	10	U	2,480	--	--	28.6	U	287	10	U		
AGP-20-45	5/1/2006	45	--	50	U	50	U	--	803	50	U	163	13,700	100	50	U	590	--	--	54.0	U	2,520	138	U			
AGP-21-35	5/1/2006	35	--	10	U	10	U	--	10	U	10	U	36.4	10	U	10	U	3,510	--	--	16.0	U	551	10	U		
AGP-21-45	5/1/2006	45	--	25	U	25	U	--	141	25	U	40.0	2,550	211	25	U	5,650	--	--	32.0	U	2,840	1,330	U			
AGP-22-35	5/2/2006	35	--	10	U	10	U	--	10.0	10	U	10	U	102	10	U	10	U	2,050	--	--	40.4	U	328	10	U	
AGP-22-45	5/2/2006	45	--	250	U	250	U	--	250	U	250	U	1,360	250	U	250	U	31,200	--	--	3,600	U	11,500	250	U		
AGP-41-55	6/19/2006	55	--	10	U	10	U	--	211	10	U	39.8	3,260	25.0	10	U	129	--	--	10	U	97.2	252	U			
AGP-41-65	6/19/2006	65	--	0.50	U	0.50	U	--	1.08	0.50	U	0.50	U	19.9	1.48	0.50	U	74.2	--	--	0.89	U	20.6	0.5	U		
AGP-41-75	6/19/2006	75	--	0.50	U	0.50	U	--	1.88	0.50	U	0.54	33.9	0.88	0.50	U	103	--	--	1.41	U	24.9	1.93	U			
AGP-23-35	5/9/2006	35	--	25	U	25	U	--	25	U	25	U	112	25	U	25	U	4,690	--	--	56.0	U	718	25	U		
AGP-23-45	5/9/2006	45	--	10	U	10	U	--	46.4	10	U	21.2	415	10	U	10	U	2,700	--	--	58.2	U	1,320	60.0	U		
AGP-24-35	5/8/2006	35	--	10	U	10	U	--	10	U	10	U	115	10	U	10	U	3,430	--	--	22.2	U	514	10	U		
AGP-24-45	5/8/2006	45	--	25	U	25	U	--	143	25	U	59.0	656	25	U	25	U	5,480	--	--	199	U	2,690	25	U		
AGP-25-35	5/4/2006	35	--	5.00	U	5.00	U	--	5.00	U	5.00	U	21.8	5.00	U	5.00	U	1,620	--	--	10.2	U	251	5	U		
AGP-25-45	5/4/2006	45	--	25	U	25	U	--	117	25	U	68.5	2,850	60.0	25	U	8,270	--	--	140	U	4,120	210	U			
AGP-26-35	5/3/2006	35	--	5.00	U	5.00	U	--	5.00	U	5.00	U	12.8	5.00	U	5.00	U	1,000	--	--	11.1	U	138	5	U		
AGP-26-45	5/3/2006	45	--	25	U	25	U	--	644	25	U	121	9,070	148	25	U	2,970	--	--	84.5	U	3,100	298	U			
AGP-27-35	5/2/2006	35	--	2.50	U	2.50	U	--	24.5	2.50	U	3.95	40.0	2.50	U	2.50	U	821	--	--	22.4	U	276	2.5	U		
AGP-27-45	5/2/2006	45	--	10	U	10	U	--	55.4	10	U	32.4	464	11.6	10	U	3,710	--	--	90.8	U	1,930	10	U			
AGP-28-25	5/3/2006	25	--	25	U	25	U	--	25	U	25	U	25	U	25	U	9,140	--	--	61.0	U	670	25	U			
AGP-28-35	5/3/2006	35	--	5.00	U	5.00	U	--	9.00	5	U	5.00	U	26.1	5.00	U	5.00	U	1,590	--	--	19.4	U	288	5	U	
AGP-28-45	5/3/2006	45	--	25	U	25	U	--	367	25	U	75.5	2,570	34.0	25	U	4,360	--	--	234	U	2,710	88.0	U			
AGP-29-25	5/4/2006	25	--	100	U	100	U	--	100	U	100	U	100	U	100	U	31,600	--	--	100	U	490	100	U			
AGP-29-35	5/4/2006	35	--	10	U	10	U	--	10	U	10	U	93.6	10	U	10	U	3,070	--	--	20.4	U	571	10	U		
AGP-29-45	5/4/2006	45	--	10	U	10	U	--	284	10	U	96.6	1,640	19.0	10	U	3,030	--	--	434	U	3,210	10	U			
AGP-30-35	5/9/2006	35	--	5.00	U	5.00	U	--	28.0	5.00	U	5.00	U	1,210	10.2	5.00	U	71.9	--	--	5	U	85.5	375	U		
AGP-31-35	5/8/2006	35	--	361	U	1.00	U	--	1.00	U	1.00	U	1.00	U	1.00	U	1	U	1	U	1	U	1	U	1	U	
AGP-31-45	5/8/2006	45	--	1.40	U	1.00	U	--	7.10	1.00	U	1.04	263	1.06	1.00	U	1	U	1	U	1	U	1	U	99.5	U	
AGP-32-35	5/9/2006	35	--	0.76	U	0.50	U	--	0.50	U	0.50	U	22.1	0.50	U	0.50	U	1	U	1	U	0.5	U	0.5	U	19.3	U
AGP-32-45	5/10/2006	45	--	2.50	U	2.50	U	--	8.00	2.50	U	2.50	U	439	2.50	U	2.50	U	2.5	U	2.5	U	2.5	U	125	U	
AGP-33-35	5/12/2006	35	--	3.69	U	0.50	U	--	1.16	0.50	U	0.50	U	30.5	0.50	U	0.50	U	15.4	--	--	0.5	U	3.94	1.51	U	
AGP-33-45	5/12/2006	45	--	10.0	U	0.50	U	--	8.67	0.50	U	0.50	U	13.7	0.50	U	0.55	U	1.61	--	--	0.5	U	0.5	U	13.7	U
AGP-34-35	5/15/2006	35	--	2.50	U	2.50	U	--	4.95	2.50	U	2.50	U	992	7.55	2.50	U	11.3	--	--	2.5	U	29.0	105	U		
AGP-34-45	5/15/2006	45	--	5.00	U	5.00	U	--	17.9	5.00	U	5.00	U	1,290	9.80	5.00	U	144	--	--	5.0	U	72.6	103	U		
AGP-35-35	5/15/2006	35	--	1.82	U	0.50	U	--	9.79	0.50	U	0.50	U	41.4	1.19	2.55	U	0.66	--	--	0.5	U	1.93	29.2	U		
AGP-35-45	5/15/2006	45	--	5.00	U	5.00	U	--	24.8	5.00	U	5.00	U	1,180	11.2	5.00	U	43.0	--	--	5.0	U	27.1	99.7	U		
AGP-36-25	5/16/2006	25	--	1.00	U	1.00	U	--	4.58	1.00	U	1.00	U	299	6.54	1.66	U	155	--	--	1.12	U	58.6	3.96	U		
AGP-36-35	5/16/2006	35	--	1.00	U	1.00	U	--	8.98	1.00	U	1.00	U	120	1.00	U	1.72	U	1.48	--	--	1.0	U	1.68	150	U	
AGP-36-45	5/16/2006	45	--	73.2	U	0.50	U	--	0.58	0.50	U	0.50	U	2.37	0.50	U	0.50	U	0.5	U	--	0.5	U	0.5	U	0.58	U

Please refer to notes at end of table.

Table C-4
Historical Depth Discreet Groundwater Analytical Results
Remedial Investigation
NuStar Vancouver Terminal

Sample	Date Collected	Depth (Feet)	Analyte Concentration in µg/L (ppb)																						
			Benzene	Chloroethane	Chloroform	2-Butanone (MEK)	1,1-DCA	1,2-DCA	1,1-DCE	cis-1,2-DCE	trans-1,2-DCE	1,2-DCP	PCE	Toluene	1,1,1-TCA	TCE	Vinyl chloride								
AGP-37-35	5/12/2006	35	--	10	U	10	U	--	10.8	10	U	10	U	2,140	20.2	10	U	376	--	10.0	U	116	146		
AGP-37-45	5/12/2006	45	--	10	U	10	U	--	37.0	10	U	11.0	U	3,850	37.4	10	U	105	--	10.0	U	87.0	620		
AGP-38-35	5/11/2006	35	--	5.00	U	5.00	U	--	7.10	5.00	U	5.00	U	586	8.30	5.00	U	1,120	--	7.10	U	201	5	U	
AGP-38-45	5/11/2006	45	--	10	U	10	U	--	42.2	10	U	16.8	U	552	13.2	10	U	3,350	--	33.2	U	887	11.6		
AGP-39-35	5/16/2006	35	--	2.50	U	2.50	U	--	9.60	2.50	U	2.50	U	119	2.50	2.50	U	409	--	3.35	U	98.1	2.5	U	
AGP-39-45	5/16/2006	45	--	10	U	10	U	--	134	10	U	52.0	U	3,510	84.6	10	U	3,280	--	81.2	U	1,700	60.4		
AGP-42-25	6/19/2006	25	--	1.00	U	1.00	U	--	1.00	U	1.00	U	U	9.02	1.00	1.00	U	160	--	1.42	U	52.5	1	U	
AGP-42-35	6/19/2006	35	--	5.00	U	5.00	U	--	22.9	5.00	U	8.90	U	198	5.50	5.00	U	1,040	--	19.3	U	645	5	U	
AGP-42-45	6/19/2006	45	--	10	U	10	U	--	33.0	10	U	27.0	U	334	10	10	U	1,580	--	33.4	U	1,170	10	U	
AGP-42-51	6/19/2006	51	--	1.00	U	1.00	U	--	11.8	1.00	U	6.20	U	141	2.38	1.00	U	244	--	5.48	U	239	1	U	
AGP-42-61	6/19/2006	61	--	1.00	U	1.00	U	--	19.7	1.00	U	9.88	U	231	2.22	1.00	U	341	--	9.54	U	318	1	U	
AGP-42-71	6/20/2006	71	--	0.50	U	0.50	U	--	3.24	0.50	U	1.44	U	41.0	0.50	0.50	U	70.4	--	1.47	U	60.4	0.5	U	
AGP-43-25	6/20/2006	25	--	0.50	U	0.50	U	--	0.50	0.50	U	0.50	U	4.31	0.50	0.50	U	32.8	--	0.5	U	15.7	0.5	U	
AGP-43-35	6/20/2006	35	--	25	U	25	U	--	25	U	25	U	U	142	25	25	U	3,840	--	25	U	1,440	25	U	
AGP-43-45	6/20/2006	45	--	50	U	50	U	--	114	50	U	72.0	U	2,410	56.0	50	U	2,420	--	101	U	12,100	50	U	
AGP-43-55	6/21/2006	55	--	0.50	U	0.50	U	--	5.88	0.50	U	1.89	U	141	2.32	0.50	U	178	--	1.15	U	101	0.74		
AGP-43-65	6/21/2006	65	--	0.50	U	0.50	U	--	0.51	0.50	U	0.50	U	9.64	0.50	0.50	U	30.0	--	0.5	U	13.9	0.5	U	
AGP-43-75	6/21/2006	75	--	0.50	U	0.50	U	--	0.70	0.50	U	0.50	U	11.1	0.50	0.50	U	69.9	--	0.5	U	25.5	0.5	U	
AGP-44-25	6/22/2006	25	--	2.50	U	2.50	U	--	2.6	2.50	U	2.50	U	117	3.55	2.50	U	498	--	6.30	U	116	2.5	U	
AGP-44-35	6/22/2006	35	--	5.00	U	5.00	U	--	5.2	5.00	U	5.00	U	462	12.7	5.00	U	802	--	7.30	U	167	5	U	
AGP-44-45	6/23/2006	45	--	10	U	10	U	--	36.6	10	U	18.4	U	580	10.0	10	U	3,330	--	29.8	U	818	10	U	
AGP-44-54	6/23/2006	54	--	5.00	U	5.00	U	--	26.7	5.00	U	24.4	U	450	6.40	5.00	U	1,780	--	19.5	U	805	5	U	
AGP-44-64	6/23/2006	64	--	0.50	U	0.50	U	--	3.26	0.50	U	1.69	U	65.2	0.99	0.50	U	103	--	1.56	U	65.6	0.5	U	
AGP-45-25	6/26/2006	25	--	2.50	U	2.50	U	--	2.50	U	2.50	U	U	2.5	2.50	U	2.50	U	449	--	2.5	U	13.1	2.5	U
AGP-45-35	6/26/2006	35	--	10	U	10	U	--	13.0	10	U	10	U	105	10	10	U	2,580	--	13.0	U	786	10	U	
AGP-45-45	6/26/2006	45	--	5.00	U	5.00	U	--	148	5.00	U	36.1	U	1,550	37.1	5.00	U	1,350	--	68.7	U	1,120	44.4		
AGP-45-51	6/26/2006	51	--	2.50	U	2.50	U	--	56.8	2.50	U	24.2	U	783	14.3	2.50	U	860	--	30.2	U	764	6.30		
AGP-47-25	6/27/2006	25	--	0.50	U	0.50	U	--	0.50	U	0.50	U	U	0.5	0.50	U	0.50	U	99.1	--	2.26	U	19.2	0.5	U
AGP-47-35	6/27/2006	35	--	2.50	U	2.50	U	--	2.50	U	2.50	U	U	8.05	2.50	2.50	U	580	--	5.20	U	106	2.5	U	
AGP-47-45	6/27/2006	45	--	25	U	25	U	--	342	25	U	65.0	U	8,440	208	25	U	1,750	--	41.0	U	1,860	337		
AGP-47-55	6/28/2006	55	--	5.00	U	5.00	U	--	30.7	5.00	U	9.80	U	1,120	9.00	5.00	U	49.2	--	5	U	133	53.5		
AGP-48-25	6/28/2006	25	--	0.50	U	0.50	U	--	1.45	0.50	U	0.50	U	26.7	1.13	0.50	U	78.2	--	1.40	U	55.0	0.5	U	
AGP-48-35	6/28/2006	35	--	0.50	U	0.50	U	--	4.02	0.50	U	0.50	U	0.81	0.50	0.50	U	0.77	--	0.53	U	0.93	0.5	U	
AGP-48-45	6/28/2006	45	--	5.00	U	5.00	U	--	36.4	5.00	U	21.1	U	1,600	9.20	5.00	U	U	--	5	U	29.4	5	U	
AGP-48-50	6/28/2006	50	--	10	U	10	U	--	57.0	10	U	34.2	U	2,320	17.6	10	U	77.8	--	10	U	293	10	U	
AGP-49-30	6/29/2006	30	--	1.00	U	1.00	U	--	2.64	1.00	U	1.14	U	7.92	1.00	1.00	U	246	--	2.10	U	192	1	U	
AGP-49-35	6/29/2006	35	--	5.00	U	5.00	U	--	9.60	5.00	U	7.20	U	57.2	5.00	5.00	U	1,550	--	15.7	U	1,070	5	U	
AGP-49-45	6/29/2006	45	--	82.4	U	10	U	--	807	10	U	89.4	U	10	10	10	U	U	--	466	U	3,240	10	U	
AGP-49-55	6/29/2006	55	--	0.50	U	0.50	U	--	3.77	0.50	U	1.25	U	101	3.29	0.50	U	62.2	--	0.92	U	64.3	0.5	U	
AGP-50-25	6/29/2006	25	--	0.50	U	0.50	U	--	0.50	U	0.50	U	U	0.5	0.50	U	0.50	U	18.1	--	0.75	U	44.8	0.5	U
AGP-50-35	6/29/2006	35	--	1.00	U	1.00	U	--	1.04	1.00	U	1.00	U	7.92	1.00	1.00	U	255	--	3.08	U	176	1	U	
AGP-50-45	6/29/2006	45	--	25	U	25	U	--	37.5	25	U	25	U	324	25	25	U	2,590	--	80.0	U	4,360	25	U	
AGP-50-55	6/29/2006	55	--	1.00	U	1.00	U	--	5.10	1.00	U	1.84	U	228	7.04	1.00	U	49.0	--	1	U	84.1	1	U	
AGP-51-35	6/13/2007	35	1.00	U	1.00	U	1.00	U	74.2	1.00	U	1.00	U	U	1.78	U	1.00	U	105	1.00	U	2.77	82.9	U	
AGP-51-45	6/13/2007	45	1.00	U	1.00	U	1.00	U	10.0	U	U	1.00	U	U	5310	104	50	U	200	1.00	U	1.00	2050	128	
AGP-51-55	6/13/2007	55	1.00	U	1.00	U	1.00	U	10.0	U	U	1.00	U	U	716	28.4	5.00	U	75.7	1.00	U	1.00	324	11.2	
AGP-52-35	6/13/2007	35	1.00	U	1.00	U	7.12	U	10.0	U	U	1.00	U	U	U	U	1.00	U	1.52	1.00	U	1.00	U	U	

Please refer to notes at end of table.

Table C-4
Historical Depth Discreet Groundwater Analytical Results
Remedial Investigation
NuStar Vancouver Terminal

Sample	Date Collected	Depth (Feet)	Analyte Concentration in µg/L (ppb)																												
			Benzene		Chloroethane		Chloroform		2-Butanone (MEK)		1,1-DCA		1,2-DCA		1,1-DCE		cis-1,2-DCE		trans-1,2-DCE		1,2-DCP		PCE		Toluene		1,1,1-TCA		TCE		Vinyl chloride
AGP-52-45	6/13/2007	45	1.00	U	1.00	U	1.00	U	10.0	U	170	U	1.00	U	U	8730	U	202	U	50	U	367	U	1.00	U	1.00	U	1750	U	372	U
AGP-52-55	6/13/2007	55	1.00	U	1.00	U	1.00	U	10.0	U	3.48	U	1.00	U	U	132	U	1.55	U	1.00	U	17.1	U	1.00	U	1.00	U	35.3	U	1.41	U
AGP-53-35	6/14/2007	35	1.00	U	1.00	U	1.00	U	10.0	U	1.00	U	1.00	U	U	U	U	U	1.00	U	15.1	U	1.00	U	1.00	U	5.72	U	U	U	
AGP-53-45	6/14/2007	45	1.00	U	1.00	U	1.00	U	10.0	U	117	U	1.00	U	U	3260	U	83.20	U	20	U	775	U	1.00	U	21.20	U	1890	U	39.6	U
AGP-53-55	6/14/2007	55	1.00	U	1.00	U	1.00	U	10.0	U	1.05	U	1.00	U	U	24.1	U	U	U	1.00	U	11.5	U	1.00	U	1.00	U	21.8	U	U	U
AGP-54-35	6/15/2007	35	1.00	U	1.00	U	1.00	U	10.0	U	1.00	U	U	U	U	8.75	U	U	5.00	U	339	U	1.00	U	5.2	U	344	U	U	U	
AGP-54-35 DUP	6/15/2007	35	1.00	U	1.00	U	1.00	U	10.0	U	1.00	U	U	U	U	7.8	U	U	5.00	U	328	U	1.00	U	5.05	U	327	U	U	U	
AGP-54-45	6/18/2007	45	1.00	U	24.9	U	1.00	U	10.0	U	84.6	U	1.00	U	1.59	54.8	U	U	1.00	U	U	U	1.00	U	15.9	U	8.95	U	1.13	U	
AGP-54-55	6/18/2007	55	1.00	U	1.00	U	1.00	U	10.0	U	4.02	U	1.00	U	U	98.8	U	U	1.00	U	14.2	U	1.00	U	1.00	U	25.8	U	1.78	U	
AGP-55-35	6/18/2007	35	1.00	U	1.00	U	1.00	U	10.0	U	13.60	U	1.00	U	U	276	U	U	10	U	704	U	1.00	U	18	U	1200	U	U	U	
AGP-56-35	6/19/2007	35	1.00	U	1.00	U	1.00	U	10.0	U	1.00	U	U	U	U	U	U	U	1.00	U	U	U	1.00	U	1.00	U	U	U	U	U	
AGP-57-35	6/19/2007	35	1.00	U	1.00	U	1.00	U	10.0	U	1.00	U	U	U	U	U	U	U	1.00	U	U	U	1.00	U	1.00	U	U	U	U	U	
AGP-57-35 DUP	6/19/2007	35	1.00	U	1.00	U	1.00	U	10.0	U	1.00	U	U	U	U	U	U	U	1.00	U	U	U	1.00	U	1.00	U	U	U	U	U	
AGP-57-45	6/20/2007	45	1.00	U	1.00	U	1.00	U	10.0	U	1.00	U	U	U	U	U	U	U	1.00	U	U	U	1.00	U	1.00	U	U	U	U	U	
AGP-57-55	6/21/2007	55	1.00	U	1.00	U	1.00	U	10.0	U	1.00	U	U	U	U	U	U	U	1.00	U	U	U	1.00	U	1.00	U	U	U	U	U	
AGP-58-35	6/21/2007	35	1.00	U	1.00	U	1.00	U	10.0	U	6.30	U	1.00	U	5.40	U	U	U	5.00	U	151	U	1.00	U	9.15	U	493	U	U	U	
AGP-58-45	6/22/2007	45	1.00	U	1.00	U	1.00	U	10.0	U	1.00	U	U	U	U	U	U	U	1.00	U	U	U	1.00	U	1.00	U	U	U	U	U	
AGP-59-45	6/22/2007	45	1.00	U	1.00	U	1.00	U	10.0	U	1.31	U	1.00	U	U	28.7	U	U	1.00	U	13.6	U	1.00	U	1.00	U	34.0	U	U	U	
AGP-59-55	6/22/2007	55	1.00	U	1.00	U	1.00	U	10.0	U	1.06	U	1.00	U	U	26.4	U	U	1.00	U	14.0	U	1.00	U	1.00	U	26.9	U	U	U	
AGP-59-65	6/22/2007	65	1.00	U	1.00	U	1.00	U	10.0	U	1.61	U	1.00	U	U	60.6	U	U	1.00	U	15.4	U	1.00	U	1.00	U	22.7	U	U	U	
AGP-60-45	6/25/2007	45	1.00	U	1.00	U	1.00	U	10.0	U	1.00	U	U	U	U	11.8	U	U	1.00	U	U	U	1.00	U	1.00	U	1.60	U	U	U	
AGP-60-55	6/25/2007	55	1.00	U	1.00	U	1.00	U	10.0	U	2.85	U	1.00	U	U	47.6	U	U	1.00	U	2.83	U	1.00	U	1.00	U	8.10	U	U	U	
AGP-60-65	6/26/2007	65	1.00	U	1.00	U	1.00	U	10.0	U	1.76	U	1.00	U	U	25.2	U	U	1.00	U	4.09	U	1.00	U	1.00	U	5.76	U	U	U	
AGP-61-45	6/26/2007	45	1.00	U	1.00	U	1.00	U	10.0	U	1.72	U	1.00	U	U	18.5	U	U	1.00	U	U	U	1.00	U	1.00	U	1.25	U	U	U	
AGP-61-55	6/26/2007	55	1.00	U	1.00	U	1.00	U	10.0	U	1.15	U	1.00	U	U	16.0	U	U	1.00	U	U	U	1.00	U	1.00	U	2.02	U	U	U	
AGP-61-55 DUP	6/26/2007	55	1.00	U	1.00	U	1.00	U	10.0	U	1.07	U	1.00	U	U	14.7	U	U	1.00	U	U	U	1.00	U	1.00	U	1.92	U	U	U	
AGP-61-65	6/26/2007	65	1.00	U	1.00	U	1.00	U	10.0	U	1.00	U	1.00	U	U	12.7	U	U	1.00	U	U	U	1.00	U	1.00	U	2.09	U	U	U	
AGP-62-35	7/18/2007	35	1.00	U	1.00	U	1.00	U	10.0	U	1.00	U	U	U	U	4.43	U	U	1.00	U	U	U	1.00	U	1.00	U	U	U	U	U	
AGP-62-55	7/18/2007	55	4.09	U	1.00	U	1.00	U	10.0	U	4.12	U	1.00	U	2.05	68.8	U	U	1.00	U	37.4	U	4.04	U	1.18	U	49.1	U	U	U	
AGP-62-65	7/18/2007	65	7.97	U	1.00	U	1.00	U	10.0	U	3.52	U	1.00	U	1.77	54.6	U	U	1.00	U	42.0	U	6.89	U	1.29	U	49.3	U	U	U	
AGP-62-75	7/18/2007	75	1.00	U	1.00	U	1.00	U	10.0	U	1.55	U	1.00	U	U	23.7	U	U	1.00	U	4.11	U	1.00	U	1.00	U	10.6	U	U	U	
AGP-62-85	7/18/2007	85	4.72	U	1.00	U	1.00	U	10.0	U	1.44	U	1.00	U	U	20.8	U	U	1.00	U	18.3	U	3.66	U	1.00	U	19.6	U	U	U	
AGP-63-35	7/19/2007	35	8.02	U	1.00	U	1.00	U	10.0	U	1.00	U	U	U	U	U	U	U	1.00	U	U	U	7.10	U	1.00	U	U	U	U	U	
AGP-63-55	7/19/2007	55	4.29	U	1.00	U	1.00	U	10.0	U	4.81	U	1.00	U	2.23	96.2	U	U	1.00	U	31.6	U	4.95	U	1.10	U	45.9	U	U	U	
AGP-63-65	7/19/2007	65	5.32	U	1.00	U	1.00	U	10.0	U	2.90	U	1.00	U	1.41	64.2	U	U	1.00	U	36.9	U	4.88	U	1.00	U	33.7	U	U	U	
AGP-63-75	7/19/2007	75	6.49	U	1.00	U	1.00	U	10.0	U	2.28	U	1.00	U	1.06	44.5	U	U	1.00	U	20.1	U	6.91	U	1.00	U	24.3	U	U	U	
AGP-63-85	7/19/2007	85	4.42	U	1.00	U	1.00	U	10.0	U	1.17	U	1.00	U	U	18.7	U	U	1.00	U	16.4	U	4.33	U	1.00	U	15.6	U	U	U	
AGP-63-85 DUP	7/19/2007	85	2.62	U	1.00	U	1.00	U	10.0	U	1.20	U	1.00	U	U	19.9	U	U	1.00	U	16.3	U	2.75	U	1.00	U	15.6	U	U	U	
AGP-64-45	7/19/2007	45	7.07	U	1.00	U	1.00	U	10.0	U	1.00	U	U	U	U	U	U	U	1.00	U	U	U	6.36	U	1.00	U	U	U	U	U	
AGP-64-55	7/19/2007	55	2.62	U	1.00	U	1.00	U	10.0	U	1.00	U	U	U	U	U	U	U	1.00	U	U	U	3.05	U	1.00	U	U	U	U	U	
AGP-64-65	7/19/2007	65	1.00	U	1.00	U	1.00	U	10.0	U	1.00	U	U	U	U	U	U	U	1.00	U	U	U	1.21	U	1.00	U	U	U	U	U	

- Notes:
1. HVOCS = Halogenated volatile organic compounds analysis by EPA Method 8260B. Results reported in micrograms per liter (µg/L).
 2. U = Not detected at or above the specified laboratory method reporting limit (MRL).
 3. DCA = Dichloroethane; DCE = Dichloroethene; DCP = Dichloropropane; PCE = Tetrachloroethene; TCA = Trichloroethane; TCE = Trichloroethene.
 4. Bold values represent detected values above the method detection limit (MDL).
 5. µg/L (ppb) = Micrograms per liter (parts per billion)

Appendix D

**Laboratory Data Quality Assurance Review and Laboratory
Analytical Reports**

Appendix D – Data Quality Review

1.0 Introduction

This appendix documents the results of a quality assurance (QA) review of the analytical data for soil and air samples collected at or in the vicinity of the Site located at the NuStar Vancouver Terminal in Vancouver, Washington. The data reviewed include soil and groundwater analytical data collected on September 20 and 21, 2010, and air sample data collected on July 29, 2010 and August 25, 2010. The soil and groundwater samples were analyzed by Kiff Analytical of Davis, California, and the air samples were analyzed by TestAmerica Laboratory of Beaverton, Oregon. Select analyses were subcontracted by Kiff Analytical to other laboratories as described in Section 2.0.

The QA review outlines the applicable quality control criteria utilized during the data review process, as well as any deviations from those criteria. Examination and validation of the laboratory summary report include:

- Analytical methods;
- Reporting limits;
- Detection limits and estimated concentrations;
- Sample holding times;
- Custody records and sample receipt;
- Spikes, blanks, and surrogates;
- Duplicates; and
- Calibration and internal standard.

The QA review did not include a review of raw data.

2.0 Analytical Methods

Chemical analyses on soil samples consisted of the following:

- Volatile Organic Compounds (VOCs) by U.S. Environmental Protection Agency (EPA) Method 8260B

Chemical analyses on groundwater samples consisted on the following:

- VOCs by EPA Method 8260B (all samples)
- Select groundwater samples were analyzed for the following chemical analyses:

Appendix D – Data Quality Review

Analysis	Method
Potassium, Iron and Manganese	EPA 6010B
Ammonia	EPA 350.1
Chloride, Nitrate, Nitrite, Sulfate	EPA 300.0
Methane, Ethane, Ethene	RSK 175
Metabolic Acids	WCAS SOP 4130
Orthophosphate	SM 4500P
Metabolic Acids	WCAS SOP 4130
Carbon Dioxide	SM 4500-CO2 D
Total Organic Carbon	415.2/5310C

Chemical analyses on soil vapor/air samples consisted of the following:

- Volatile Organic Compounds (VOCs) by EPA Method TO-15 GC/MS (Med-Level)

3.0 Quality Assurance Objectives and Review Procedures

The general QA objectives for this project were to develop and implement procedures for obtaining, evaluating, and confirming the usability of data of a specified quality for soil and air samples. To collect such information, analytical data must have an appropriate degree of accuracy and reproducibility, samples collected must be representative of actual field conditions, and samples must be collected and analyzed using unbroken chain-of-custody (COC) procedures.

Reporting limits and analytical results were compared to action levels for each parameter in the media of concern. Precision, accuracy, representativeness, completeness, and comparability parameters used to indicate data quality are defined below.

Reporting Limits. Method reporting limits (MRLs) are set by the laboratory and are based on instrumentation abilities, sample matrix, and suggested MRLs by the EPA or the Washington State Department of Ecology (Ecology). In some cases, the MRLs are raised due to high concentrations of analytes in the samples or matrix interferences. MRLs are generally consistent with industry standards and below promulgated regulatory standards when possible (if not raised, as discussed above).

Detection Limits and Estimated Concentrations. The method detection limit (MDL) is the lowest quantity of a substance that can be distinguished from the absence of that substance within a stated confidence limit. The MDL is estimated from the mean of the blank, the standard deviation of the blank, and some confidence factor. A substance detected above the MDL, but below the MRL, is flagged with a "J" qualifier for the

Appendix D – Data Quality Review

affected sample, indicating that the numerical result is an estimate and the accuracy of the estimate improves as the result approaches the MRL.

Holding Times. Holding times are the length of time a sample can be stored after collection and prior to analysis without potentially affecting the analytical results. Holding times vary with the analyte, sample matrix, and analytical methodology used to quantify the analyte's concentration.

Custody Records and Sample Receipt. COC refers to the document or paper trail showing the seizure, custody, control, transfer, analysis, and disposition of physical and electronic evidence. The sample receipt identifies the condition of samples upon arrival at the analytical laboratory.

Method Blanks. A method, or laboratory, blank is a sample prepared in the laboratory along with the actual samples and analyzed for the same parameters at the same time. It is used to assess if detected contaminants may have been the result of contamination of the samples in the laboratory.

Laboratory Control Sample (LCS). An LCS is a sample of known concentration that is carried through the digestion/extraction and analysis process. The percent recovery, expressed as a percentage of the theoretical concentration, has statistical control limits indicating that the analytic process is "in control".

Laboratory Control Sample Duplicate (LCSD). In addition, a second LCS is prepared as above and analyzed. This is compared to the initial laboratory control sample to assess the precision of the analytical method (i.e., relative percent difference [RPD]).

Matrix Spike Analyses. A Matrix Spike (MS) and Matrix Spike Duplicate (MSD) analysis involves two aliquots of an environmental sample that is spiked with known concentrations of target analytes. The percent recovery of the target analytes also has statistical control limits. The RPD between the MS and MSD is calculated.

Laboratory Duplicate. A laboratory duplicate is a second analysis of the quality assurance/quality control (QA/QC) sample, which serves as an internal check on laboratory quality as well as potential variability of the sample matrix. The laboratory duplicate is analyzed and compared to the primary sample analysis to assess the precision of the analytical method. This comparison can be expressed by the RPD between the original and duplicate sample.

Surrogate Recovery. Surrogates are organic compounds that are similar in chemical composition to the analytes of interest and spiked into environmental and batch QC samples prior to sample preparation and analysis. Surrogate recoveries for environmental samples are used to evaluate matrix interference on a sample-specific basis.

Appendix D – Data Quality Review

Trip Blanks. The purpose of trip blanks is to assess the sample representativeness by determining whether contaminants have been introduced into the samples while they were handled in the field and in transit.

4.0 QA/QC Review Results

The following subsections document the results of the QA review for the soil and soil vapor sampling events.

4.1 September 20 and 21, 2010 — Soil Sampling Event

The data reviewed includes soil data from samples collected on September 20 and 21, 2010.

Reporting Limits. The bromomethane reporting limit was raised for samples CB-1 (9), CB-1 (29.5), CB-2 (9.5), CB-2 (42), CB-3 (18) and CB-3 (29) due to a matrix effect. The sample data were flagged with an "RL1" qualifier.

Detection Limits and Estimated Concentrations. No estimated values were reported.

Holding Times. Sample analyses were completed within specified holding times.

Custody Records and Sample Receipt. Samples were received consistent with the accompanying COC form.

Method Blanks. No analytes were detected in the method blanks.

LCS. Percent recoveries of the LCS were within control limits for all analytes.

LCSD. RPD were within acceptance limits for all analytes.

MS Analyses. MS and MSD results associated with samples CB-1 (9), CB-1 (29.5), CB-2(42), CB-3 (18), CB-3 (29), and CB-4 (38.5) for the analytes 1,2,3-trichlorobenzene, 1,2,4-trichlorobenzene, hexachlorobutadiene, and naphthalene were outside of control limits. Since the LCS recoveries were within control limits, the accuracy of the system is considered acceptable, and no data are flagged.

MS and MSD results associated with samples CB-1 (9), CB-1 (17.5), CB-1 (37.5), CB-2 (9.5), CB-2 (18), CB-2 (28), CB-3 (9), CB-4 (18) and CB-4 (28) for the analytes 1,1,1,2-tetrachloroethane, 1,2,3-trichlorobenzene, 1,2,4-trichlorobenzene, 1,2,4-trimethylbenzene, 1,2-dichlorobenzene, 1,3,5-trimethylbenzene, 1,3-dichlorobenzene, 1,4-dichlorobenzene, 2+4-chlorotoluene, bromobenzene,



Appendix D – Data Quality Review

chlorobenzene, hexachlorobutadiene, isopropyl benzene, naphthalene, styrene, cis-,3-Ddchloropropene, n-butylbenzene, n-proylbenzene, p-isopropyltoluene, sec-butylbenzene, t-1,3-dichloropropene, and tert-butylbenzene were outside of control limits. Since the LCS recoveries were within control limits, no data are flagged.

Laboratory Duplicate. No laboratory duplicate was analyzed.

Surrogate Recovery. Surrogate recoveries were within control limits.

Field Duplicate. No field duplicates were collected during this sampling event.

Trip Blanks. No trip blanks were collected for analysis during this sampling event.

Other QC. Methanol extracts of soil samples were subsampled prior to weighing for determining the soil mass present. From each extract, 100 microliter aliquots were removed. To compensate for this, an adjustment of 0.08g was included in the mass calculation. This scenario applies to samples CB-1 (9), CB-1 (29.5), CB-2 (9.5), CB-2 (42), CB-3 (9), CB-3 (18), CB-3 (290), CB-4 (18) and CB-4 (38.5) by EPA Method 8260B.

4.2 September 20 and 21, 2010 — Groundwater Sampling Event

The data reviewed includes groundwater data from samples collected on September 20 and 21, 2010.

Reporting Limits. No reporting limits were elevated in groundwater samples from this event.

Detection Limits and Estimated Concentrations. No estimated values were reported.

Holding Times. Sample analyses were completed within specified hold times.

Custody Records and Sample Receipt. Samples were received consistent with the accompanying chain-of-custody form.

Method Blanks. No analytes were detected in the method blanks.

LCS. Percent recoveries of the LCS were within control limits for all analytes.

LCSD. No LCSD sample was analyzed in the VOC analysis (Method 8260B). LCSD samples for other analytes and were found to be within control limits.

Appendix D – Data Quality Review

MS Analyses. The MS sample associated with sample SB-3 (35) for the analyte chloride was within acceptable recovery limits. The MSD results associated with sample CB-3 (35) for the analyte chloride were affected by the analyte concentration present in the un-spiked sample. The results may be biased low. The LCS was within acceptable control limits for this sample; therefore, the results are not flagged.

Laboratory Duplicate. No laboratory duplicate was analyzed.

Surrogate Recovery. Surrogate recoveries were within control limits.

Field Duplicate. A duplicate VOC sample for CB-2(45) was analyzed for VOCs (Method 8260B). The RPD between the sample and duplicate exceeded the control limit of +/- 30 percent for the following analytes: 1,1,1-trichloroethane, 1,1-dichloroethene, tetrachloroethene, trichloroethene, and vinyl chloride. The sample and duplicate results for these analytes are flagged with an "M" qualifier indicating that the RPD values between the sample and duplicate were outside of acceptable control limits. The laboratory noted that there was not reproducibility between the individual sample bottles collected for sample CB-2(45). The laboratory did not note this discrepancy in any of the other samples; therefore, it was not considered necessary to flag any additional samples.

Field Blanks. Two field blanks were submitted for analysis. No analytes were detected in either of the field blanks.

4.3 July 29 and August 25, 2010 Soil Vapor Extraction Sampling Data

The data reviewed includes soil vapor extraction (SVE) air samples collected on July 29 and August 25, 2010. Samples were analyzed for VOCs using Modified EPA Method TO-15.

Reporting Limits. No elevated MRLs were reported in any of the air samples.

Detection Limits and Estimated Concentrations. Estimated concentrations were reported for target compound hits that were below the reporting limit but greater than the MDL. The estimated concentrations are flagged with a "J" qualifier.

Holding Times. Sample analyses were completed within specified hold times.

Custody Records and Sample Receipt. Samples were received in acceptable condition in accordance with the COC.

Method Blanks. No analytes were identified in the laboratory blank sample above reporting limits.

LCS. Percent recoveries of the LCS were within control limits.

Appendix D – Data Quality Review

LCSD. During the July 29, 2010 sampling event, hexachlorobutadiene recovery in the LCS was slightly above control limits in the LCSD. During the August 25, 2010 sampling event, acetone recovery in the LCS was slightly below control limits in the LCSD. Acetone and hexachlorobutadiene were not detected in the batch samples. The referenced analytes were within control limits in the LCS and the RPD between the LCS/LCSD were within acceptable limits; therefore, the data were not flagged.

Lab Duplicate. With the exception of the LCSD, a laboratory duplicate was not analyzed with the air sample batches. The RPD between the LCS and LCSD were within acceptable limits for all analytes, indicating that the precision of the sampling system was acceptable.

Surrogate Recovery. Surrogate recoveries were within QC limits.

Field Duplicate. No field duplicates were collected during this sampling event.



August 13, 2010

Stephanie Bosze
Ash Creek Associates, Inc.
3015 SW First Avenue
Portland, OR 97201

RE: NuStar Vancouver

Enclosed are the results of analyses for samples received by the laboratory on 07/29/10 18:10.
The following list is a summary of the Work Orders contained in this report, generated on 08/13/10
15:55.

If you have any questions concerning this report, please feel free to contact me.

<u>Work Order</u>	<u>Project</u>	<u>ProjectNumber</u>
PTG0837	NuStar Vancouver	1126-09

TestAmerica Portland



Christina Woodcock For Darrell Auvil, Project Manager

The results in this report apply to the samples analyzed in accordance with the chain of custody document. This analytical report shall not be reproduced except in full, without the written approval of the laboratory.

Ash Creek Associates, Inc.

3015 SW First Avenue
Portland, OR 97201

Project Name: **NuStar Vancouver**
Project Number: 1126-09
Project Manager: Stephanie Bosze

Report Created:
08/13/10 15:55

ANALYTICAL REPORT FOR SAMPLES

Sample ID	Laboratory ID	Matrix	Date Sampled	Date Received
Post Carbon-072910	PTG0837-01	Air	07/29/10 09:31	07/29/10 18:10
Pre Carbon-072910	PTG0837-02	Air	07/29/10 09:45	07/29/10 18:10

TestAmerica Portland



Christina Woodcock For Darrell Auvil, Project Manager

The results in this report apply to the samples analyzed in accordance with the chain of custody document. This analytical report shall not be reproduced except in full, without the written approval of the laboratory.

Ash Creek Associates, Inc.

3015 SW First Avenue
Portland, OR 97201

Project Name: **NuStar Vancouver**

Project Number: 1126-09

Project Manager: Stephanie Bosze

Report Created:

08/13/10 15:55

EPA TO15 (Med-level) - Volatile Organic Compounds by GC/MS

TestAmerica Los Angeles

Analyte	Method	Result	MDL*	MRL	Units	Dil	Batch	Prepared	Analyzed	Notes
PTG0837-01 (Post Carbon-072910)			Air					Sampled: 07/29/10 09:31		
Acetone	EPA TO15	ND	----	49	ug/m3	2.06x	10H0063	08/04/10 10:15	08/07/10 20:07	
Benzene	"	ND	----	20	"	"	"	"	"	
Benzyl chloride	"	ND	----	110	"	"	"	"	"	
Bromodichloromethane	"	ND	----	28	"	"	"	"	"	
Bromoform	"	ND	----	43	"	"	"	"	"	
Bromomethane	"	ND	----	32	"	"	"	"	"	
2-Butanone (MEK)	"	ND	----	61	"	"	"	"	"	
Carbon disulfide	"	ND	----	64	"	"	"	"	"	
Carbon tetrachloride	"	ND	----	26	"	"	"	"	"	
Chlorobenzene	"	ND	----	19	"	"	"	"	"	
Dibromochloromethane	"	ND	----	35	"	"	"	"	"	
Chloroethane	"	ND	----	22	"	"	"	"	"	
Chloroform	"	ND	----	20	"	"	"	"	"	
Chloromethane	"	ND	----	17	"	"	"	"	"	
1,2-Dibromoethane (EDB)	"	ND	----	32	"	"	"	"	"	
1,2-Dichlorobenzene	"	ND	----	25	"	"	"	"	"	
1,3-Dichlorobenzene	"	ND	----	50	"	"	"	"	"	
1,4-Dichlorobenzene	"	ND	----	50	"	"	"	"	"	
Dichlorodifluoromethane	"	ND	----	31	"	"	"	"	"	
1,1-Dichloroethane	"	40	----	17	"	"	"	"	"	
1,2-Dichloroethane	"	ND	----	25	"	"	"	"	"	
cis-1,2-Dichloroethene	"	1700	----	16	"	"	"	"	"	
trans-1,2-Dichloroethene	"	ND	----	16	"	"	"	"	"	
1,1-Dichloroethene	"	42	----	16	"	"	"	"	"	
1,2-Dichloropropane	"	ND	----	29	"	"	"	"	"	
cis-1,3-Dichloropropene	"	ND	----	19	"	"	"	"	"	
trans-1,3-Dichloropropene	"	ND	----	19	"	"	"	"	"	
1,2-Dichloro-1,1,2,2-tetrafluoroethane	"	ND	----	29	"	"	"	"	"	
Ethylbenzene	"	ND	----	18	"	"	"	"	"	
4-Ethyltoluene	"	ND	----	20	"	"	"	"	"	
Hexachlorobutadiene	"	ND	----	88	"	"	"	"	"	
2-Hexanone	"	ND	----	84	"	"	"	"	"	
Methylene chloride	"	ND	----	14	"	"	"	"	"	
4-Methyl-2-pentanone (MIBK)	"	ND	----	84	"	"	"	"	"	
Styrene	"	ND	----	18	"	"	"	"	"	

TestAmerica Portland



Christina Woodcock For Darrell Auvil, Project Manager

The results in this report apply to the samples analyzed in accordance with the chain of custody document. This analytical report shall not be reproduced except in full, without the written approval of the laboratory.

Ash Creek Associates, Inc.

3015 SW First Avenue
Portland, OR 97201

Project Name: **NuStar Vancouver**

Project Number: 1126-09

Project Manager: Stephanie Bosze

Report Created:

08/13/10 15:55

EPA TO15 (Med-level) - Volatile Organic Compounds by GC/MS

TestAmerica Los Angeles

Analyte	Method	Result	MDL*	MRL	Units	Dil	Batch	Prepared	Analyzed	Notes
PTG0837-01 (Post Carbon-072910)				Air		Sampled: 07/29/10 09:31				
1,1,2,2-Tetrachloroethane	EPA TO15	ND	----	28	ug/m3	2.06x	10H0063	08/04/10 10:15	08/07/10 20:07	
Tetrachloroethene	"	140	----	28	"	"	"	"	"	
Toluene	"	ND	----	16	"	"	"	"	"	
1,2,4-Trichlorobenzene	"	ND	----	76	"	"	"	"	"	
1,1,1-Trichloroethane	"	1500	----	22	"	"	"	"	"	
1,1,2-Trichloroethane	"	ND	----	22	"	"	"	"	"	
Trichloroethene	"	1500	----	22	"	"	"	"	"	
Trichlorofluoromethane	"	ND	----	23	"	"	"	"	"	
1,1,2-Trichloro-1,2,2-trifluoroethane	"	ND	----	32	"	"	"	"	"	
1,2,4-Trimethylbenzene	"	ND	----	30	"	"	"	"	"	
1,3,5-Trimethylbenzene	"	ND	----	41	"	"	"	"	"	
Vinyl acetate	"	ND	----	150	"	"	"	"	"	
Vinyl chloride	"	ND	----	21	"	"	"	"	"	
m,p-Xylene	"	ND	----	36	"	"	"	"	"	
o-Xylene	"	ND	----	18	"	"	"	"	"	
Xylenes, total	"	ND	----	18	"	"	"	"	"	

Surrogate(s): 4-Bromofluorobenzene 92% 70 - 130 % 1x "

1,2-Dichloroethane-d4 111% 70 - 130 % " "

Toluene-d8 92% 70 - 130 % " "

PTG0837-02 (Pre Carbon-072910)				Air		Sampled: 07/29/10 09:45				
Acetone	EPA TO15	ND	----	1400	ug/m3	57.1x	10H0063	08/04/10 10:15	08/07/10 20:45	
Benzene	"	ND	----	550	"	"	"	"	"	
Benzyl chloride	"	ND	----	3000	"	"	"	"	"	
Bromodichloromethane	"	ND	----	770	"	"	"	"	"	
Bromoform	"	ND	----	1200	"	"	"	"	"	
Bromomethane	"	ND	----	890	"	"	"	"	"	
2-Butanone (MEK)	"	ND	----	1700	"	"	"	"	"	
Carbon disulfide	"	ND	----	1800	"	"	"	"	"	
Carbon tetrachloride	"	ND	----	720	"	"	"	"	"	
Chlorobenzene	"	ND	----	530	"	"	"	"	"	
Dibromochloromethane	"	ND	----	970	"	"	"	"	"	
Chloroethane	"	ND	----	600	"	"	"	"	"	
Chloroform	"	ND	----	560	"	"	"	"	"	
Chloromethane	"	ND	----	470	"	"	"	"	"	
1,2-Dibromoethane (EDB)	"	ND	----	880	"	"	"	"	"	

TestAmerica Portland



Christina Woodcock For Darrell Auvil, Project Manager

The results in this report apply to the samples analyzed in accordance with the chain of custody document. This analytical report shall not be reproduced except in full, without the written approval of the laboratory.

Ash Creek Associates, Inc.

3015 SW First Avenue
Portland, OR 97201

Project Name: **NuStar Vancouver**

Project Number: 1126-09

Project Manager: Stephanie Bosze

Report Created:

08/13/10 15:55

EPA TO15 (Med-level) - Volatile Organic Compounds by GC/MS

TestAmerica Los Angeles

Analyte	Method	Result	MDL*	MRL	Units	Dil	Batch	Prepared	Analyzed	Notes
PTG0837-02 (Pre Carbon-072910)										
			Air							Sampled: 07/29/10 09:45
1,2-Dichlorobenzene	"	ND	----	690	"	"	"	"	"	
1,3-Dichlorobenzene	"	ND	----	1400	"	"	"	"	"	
1,4-Dichlorobenzene	"	ND	----	1400	"	"	"	"	"	
Dichlorodifluoromethane	"	ND	----	850	"	"	"	"	"	
1,1-Dichloroethane	"	ND	----	460	"	"	"	"	"	
1,2-Dichloroethane	"	ND	----	690	"	"	"	"	"	
cis-1,2-Dichloroethene	"	ND	----	450	"	"	"	"	"	
trans-1,2-Dichloroethene	"	ND	----	450	"	"	"	"	"	
1,1-Dichloroethene	"	ND	----	450	"	"	"	"	"	
1,2-Dichloropropane	"	ND	----	790	"	"	"	"	"	
cis-1,3-Dichloropropene	"	ND	----	520	"	"	"	"	"	
trans-1,3-Dichloropropene	"	ND	----	520	"	"	"	"	"	
1,2-Dichloro-1,1,2,2-tetrafluoroethane	"	ND	----	800	"	"	"	"	"	
Ethylbenzene	"	ND	----	500	"	"	"	"	"	
4-Ethyltoluene	"	ND	----	560	"	"	"	"	"	
Hexachlorobutadiene	"	ND	----	2400	"	"	"	"	"	
2-Hexanone	"	ND	----	2300	"	"	"	"	"	
Methylene chloride	"	ND	----	400	"	"	"	"	"	
4-Methyl-2-pentanone (MIBK)	"	ND	----	2300	"	"	"	"	"	
Styrene	"	ND	----	490	"	"	"	"	"	
1,1,2,2-Tetrachloroethane	"	ND	----	780	"	"	"	"	"	
Tetrachloroethene	"	62000	----	780	"	"	"	"	"	
Toluene	"	ND	----	430	"	"	"	"	"	
1,2,4-Trichlorobenzene	"	ND	----	2100	"	"	"	"	"	
1,1,1-Trichloroethane	"	ND	----	620	"	"	"	"	"	
1,1,2-Trichloroethane	"	ND	----	620	"	"	"	"	"	
Trichloroethene	"	1900	----	610	"	"	"	"	"	
Trichlorofluoromethane	"	ND	----	640	"	"	"	"	"	
1,1,2-Trichloro-1,2,2-trifluoroethane	"	ND	----	880	"	"	"	"	"	
1,2,4-Trimethylbenzene	"	ND	----	840	"	"	"	"	"	
1,3,5-Trimethylbenzene	"	ND	----	1100	"	"	"	"	"	
Vinyl acetate	"	ND	----	4000	"	"	"	"	"	
Vinyl chloride	"	ND	----	580	"	"	"	"	"	
m,p-Xylene	"	ND	----	990	"	"	"	"	"	
o-Xylene	"	ND	----	500	"	"	"	"	"	

TestAmerica Portland



Christina Woodcock For Darrell Auvil, Project Manager

The results in this report apply to the samples analyzed in accordance with the chain of custody document. This analytical report shall not be reproduced except in full, without the written approval of the laboratory.

Ash Creek Associates, Inc.	Project Name: NuStar Vancouver	Report Created:
3015 SW First Avenue	Project Number: 1126-09	08/13/10 15:55
Portland, OR 97201	Project Manager: Stephanie Bosze	

EPA TO15 (Med-level) - Volatile Organic Compounds by GC/MS
 TestAmerica Los Angeles

Analyte	Method	Result	MDL*	MRL	Units	Dil	Batch	Prepared	Analyzed	Notes	
PTG0837-02 (Pre Carbon-072910)											
			Air							Sampled: 07/29/10 09:45	
Xylenes, total	EPA TO15	ND	----	500	ug/m3	57.1x	10H0063	08/04/10 10:15	08/07/10 20:45		
Surrogate(s):	4-Bromofluorobenzene			94%		70 - 130 %	1x				"
	1,2-Dichloroethane-d4			94%		70 - 130 %	"				"
	Toluene-d8			95%		70 - 130 %	"				"

TestAmerica Portland



Christina Woodcock For Darrell Auvil, Project Manager

The results in this report apply to the samples analyzed in accordance with the chain of custody document. This analytical report shall not be reproduced except in full, without the written approval of the laboratory.

Ash Creek Associates, Inc.

3015 SW First Avenue
Portland, OR 97201

Project Name: **NuStar Vancouver**

Project Number: 1126-09

Project Manager: Stephanie Bosze

Report Created:

08/13/10 15:55

EPA TO15 (Med-level) - Volatile Organic Compounds by GC/MS - Laboratory Quality Control Results

TestAmerica Los Angeles

QC Batch: 10H0063

Air Preparation Method: METHOD-MSMED

Analyte	Method	Result	MDL*	MRL	Units	Dil	Source Result	Spike Amt	% REC	(Limits)	% RPD	(Limits)	Analyzed	Notes
Blank (10H0063-BLK1)													Extracted: 08/07/10 00:00	
Acetone	EPA TO15	ND	---	24	ug/m3	1x	--	--	--	--	--	--	08/07/10 14:28	
Benzene	"	ND	---	9.6	"	"	--	--	--	--	--	--		
Benzyl chloride	"	ND	---	52	"	"	--	--	--	--	--	--		
Bromodichloromethane	"	ND	---	13	"	"	--	--	--	--	--	--		
Bromoform	"	ND	---	21	"	"	--	--	--	--	--	--		
Bromomethane	"	ND	---	16	"	"	--	--	--	--	--	--		
2-Butanone (MEK)	"	ND	---	29	"	"	--	--	--	--	--	--		
Carbon disulfide	"	ND	---	31	"	"	--	--	--	--	--	--		
Carbon tetrachloride	"	ND	---	13	"	"	--	--	--	--	--	--		
Chlorobenzene	"	ND	---	9.2	"	"	--	--	--	--	--	--		
Dibromochloromethane	"	ND	---	17	"	"	--	--	--	--	--	--		
Chloroethane	"	ND	---	11	"	"	--	--	--	--	--	--		
Chloroform	"	ND	---	9.8	"	"	--	--	--	--	--	--		
Chloromethane	"	ND	---	8.3	"	"	--	--	--	--	--	--		
1,2-Dibromoethane (EDB)	"	ND	---	15	"	"	--	--	--	--	--	--		
1,2-Dichlorobenzene	"	ND	---	12	"	"	--	--	--	--	--	--		
1,3-Dichlorobenzene	"	ND	---	24	"	"	--	--	--	--	--	--		
1,4-Dichlorobenzene	"	ND	---	24	"	"	--	--	--	--	--	--		
Dichlorodifluoromethane	"	ND	---	15	"	"	--	--	--	--	--	--		
1,1-Dichloroethane	"	ND	---	8.1	"	"	--	--	--	--	--	--		
1,2-Dichloroethane	"	ND	---	12	"	"	--	--	--	--	--	--		
cis-1,2-Dichloroethene	"	ND	---	7.9	"	"	--	--	--	--	--	--		
trans-1,2-Dichloroethene	"	ND	---	7.9	"	"	--	--	--	--	--	--		
1,1-Dichloroethene	"	ND	---	7.9	"	"	--	--	--	--	--	--		
1,2-Dichloropropane	"	ND	---	14	"	"	--	--	--	--	--	--		
cis-1,3-Dichloropropene	"	ND	---	9.1	"	"	--	--	--	--	--	--		
trans-1,3-Dichloropropene	"	ND	---	9.1	"	"	--	--	--	--	--	--		
1,2-Dichloro-1,1,2,2-tetrafluoroethane	"	ND	---	14	"	"	--	--	--	--	--	--		
Ethylbenzene	"	ND	---	8.7	"	"	--	--	--	--	--	--		
4-Ethyltoluene	"	ND	---	9.8	"	"	--	--	--	--	--	--		
Hexachlorobutadiene	"	ND	---	43	"	"	--	--	--	--	--	--		
2-Hexanone	"	ND	---	41	"	"	--	--	--	--	--	--		
Methylene chloride	"	ND	---	6.9	"	"	--	--	--	--	--	--		
4-Methyl-2-pentanone (MIBK)	"	ND	---	41	"	"	--	--	--	--	--	--		
Styrene	"	ND	---	8.5	"	"	--	--	--	--	--	--		
1,1,2,2-Tetrachloroethane	"	ND	---	14	"	"	--	--	--	--	--	--		
Tetrachloroethene	"	ND	---	14	"	"	--	--	--	--	--	--		
Toluene	"	ND	---	7.5	"	"	--	--	--	--	--	--		
1,2,4-Trichlorobenzene	"	ND	---	37	"	"	--	--	--	--	--	--		

TestAmerica Portland



Christina Woodcock For Darrell Auvil, Project Manager

The results in this report apply to the samples analyzed in accordance with the chain of custody document. This analytical report shall not be reproduced except in full, without the written approval of the laboratory.

Ash Creek Associates, Inc.

3015 SW First Avenue
 Portland, OR 97201

Project Name: **NuStar Vancouver**

Project Number: 1126-09

Project Manager: Stephanie Bosze

Report Created:

08/13/10 15:55

EPA TO15 (Med-level) - Volatile Organic Compounds by GC/MS - Laboratory Quality Control Results

TestAmerica Los Angeles

QC Batch: 10H0063

Air Preparation Method: METHOD-MSMED

Analyte	Method	Result	MDL*	MRL	Units	Dil	Source Result	Spike Amt	% REC	(Limits)	% RPD	(Limits)	Analyzed	Notes
---------	--------	--------	------	-----	-------	-----	---------------	-----------	-------	----------	-------	----------	----------	-------

Blank (10H0063-BLK1)

Extracted: 08/07/10 00:00

1,1,1-Trichloroethane	EPA TO15	ND	---	11	ug/m3	1x	--	--	--	--	--	--	08/07/10 14:28	
1,1,2-Trichloroethane	"	ND	---	11	"	"	--	--	--	--	--	--	"	
Trichloroethene	"	ND	---	11	"	"	--	--	--	--	--	--	"	
Trichlorofluoromethane	"	ND	---	11	"	"	--	--	--	--	--	--	"	
1,1,2-Trichloro-1,2,2-trifluoroethane	"	ND	---	15	"	"	--	--	--	--	--	--	"	
1,2,4-Trimethylbenzene	"	ND	---	15	"	"	--	--	--	--	--	--	"	
1,3,5-Trimethylbenzene	"	ND	---	20	"	"	--	--	--	--	--	--	"	
Vinyl acetate	"	ND	---	70	"	"	--	--	--	--	--	--	"	
Vinyl chloride	"	ND	---	10	"	"	--	--	--	--	--	--	"	
m,p-Xylene	"	ND	---	17	"	"	--	--	--	--	--	--	"	
o-Xylene	"	ND	---	8.7	"	"	--	--	--	--	--	--	"	
Xylenes, total	"	ND	---	8.7	"	"	--	--	--	--	--	--	"	

Surrogate(s): 4-Bromofluorobenzene	Recovery: 92%	Limits: 70-130%	"	08/07/10 14:28
1,2-Dichloroethane-d4	99%	70-130%	"	"
Toluene-d8	96%	70-130%	"	"

LCS (10H0063-BS1)

Extracted: 08/07/10 00:00

Acetone	EPA TO15	92.3	---	24	ug/m3	1x	--	125	74%	(70-130)	--	--	08/07/10 12:38	
Benzene	"	137	---	9.6	"	"	--	169	81%	"	--	--	"	
Bromodichloromethane	"	330	---	13	"	"	--	335	98%	"	--	--	"	
Bromomethane	"	211	---	16	"	"	--	194	109%	"	--	--	"	
2-Butanone (MEK)	"	120	---	29	"	"	--	164	73%	"	--	--	"	
Carbon disulfide	"	173	---	31	"	"	--	156	111%	"	--	--	"	
Chlorobenzene	"	208	---	9.2	"	"	--	244	85%	"	--	--	"	
1,4-Dichlorobenzene	"	293	---	24	"	"	--	301	98%	"	--	--	"	
cis-1,2-Dichloroethene	"	177	---	7.9	"	"	--	212	83%	"	--	--	"	
Hexachlorobutadiene	"	519	---	43	"	"	--	491	106%	"	--	--	"	
1,1,2-Trichloroethane	"	249	---	11	"	"	--	273	91%	"	--	--	"	
Trichloroethene	"	259	---	11	"	"	--	269	96%	"	--	--	"	
1,2,4-Trimethylbenzene	"	219	---	15	"	"	--	246	89%	"	--	--	"	
Vinyl chloride	"	104	---	10	"	"	--	128	81%	"	--	--	"	
m,p-Xylene	"	389	---	17	"	"	--	434	89%	"	--	--	"	
o-Xylene	"	199	---	8.7	"	"	--	228	87%	"	--	--	"	

Surrogate(s): 4-Bromofluorobenzene	Recovery: 94%	Limits: 70-130%	"	08/07/10 12:38
1,2-Dichloroethane-d4	95%	70-130%	"	"
Toluene-d8	95%	70-130%	"	"

TestAmerica Portland



Christina Woodcock For Darrell Auvil, Project Manager

The results in this report apply to the samples analyzed in accordance with the chain of custody document. This analytical report shall not be reproduced except in full, without the written approval of the laboratory.

Ash Creek Associates, Inc.	Project Name: NuStar Vancouver	Report Created:
3015 SW First Avenue	Project Number: 1126-09	08/13/10 15:55
Portland, OR 97201	Project Manager: Stephanie Bosze	

EPA TO15 (Med-level) - Volatile Organic Compounds by GC/MS - Laboratory Quality Control Results
 TestAmerica Los Angeles

QC Batch: 10H0063 **Air Preparation Method: METHOD-MSMED**

Analyte	Method	Result	MDL*	MRL	Units	Dil	Source Result	Spike Amt	% REC	(Limits)	% RPD	(Limits)	Analyzed	Notes
LCS Dup (10H0063-BSD1)										Extracted: 08/07/10 00:00				
Acetone	EPA TO15	103	---	24	ug/m3	1x	--	125	82%	(70-130)	11%	(25)	08/07/10 13:45	
Benzene	"	138	---	9.6	"	"	--	169	81%	"	0.8%	"	"	
Bromodichloromethane	"	340	---	13	"	"	--	335	102%	"	3%	"	"	
Bromomethane	"	226	---	16	"	"	--	194	116%	"	7%	"	"	
2-Butanone (MEK)	"	123	---	29	"	"	--	164	75%	"	3%	"	"	
Carbon disulfide	"	177	---	31	"	"	--	156	114%	"	2%	"	"	
Chlorobenzene	"	202	---	9.2	"	"	--	244	83%	"	3%	"	"	
1,4-Dichlorobenzene	"	312	---	24	"	"	--	301	104%	"	6%	"	"	
cis-1,2-Dichloroethene	"	180	---	7.9	"	"	--	212	85%	"	2%	"	"	
Hexachlorobutadiene	"	647	---	43	"	"	--	491	132%	"	22%	"	"	L5
1,1,2-Trichloroethane	"	264	---	11	"	"	--	273	97%	"	6%	"	"	
Trichloroethene	"	272	---	11	"	"	--	269	101%	"	5%	"	"	
1,2,4-Trimethylbenzene	"	228	---	15	"	"	--	246	93%	"	4%	"	"	
Vinyl chloride	"	123	---	10	"	"	--	128	96%	"	16%	"	"	
m,p-Xylene	"	397	---	17	"	"	--	434	91%	"	2%	"	"	
o-Xylene	"	202	---	8.7	"	"	--	228	89%	"	2%	"	"	
<i>Surrogate(s): 4-Bromofluorobenzene</i>		<i>Recovery: 94%</i>		<i>Limits: 70-130%</i>		<i>"</i>				<i>08/07/10 13:45</i>				
<i>1,2-Dichloroethane-d4</i>		<i>92%</i>		<i>70-130%</i>		<i>"</i>				<i>"</i>				
<i>Toluene-d8</i>		<i>99%</i>		<i>70-130%</i>		<i>"</i>				<i>"</i>				

TestAmerica Portland



Christina Woodcock For Darrell Auvil, Project Manager

The results in this report apply to the samples analyzed in accordance with the chain of custody document. This analytical report shall not be reproduced except in full, without the written approval of the laboratory.

Ash Creek Associates, Inc.

3015 SW First Avenue
Portland, OR 97201

Project Name: **NuStar Vancouver**
Project Number: 1126-09
Project Manager: Stephanie Bosze

Report Created:
08/13/10 15:55

Notes and Definitions

Report Specific Notes:

- L5 - Analyte recovery outside of specified criteria. Individual analyte criteria exceedences allowed for multi-component analyses without disqualification of data per NELAC Standard, DOD QSM and/or AFCEE QAPP.

Laboratory Reporting Conventions:

- DET - Analyte DETECTED at or above the Reporting Limit. Qualitative Analyses only.
- ND - Analyte NOT DETECTED at or above the reporting limit (MDL or MRL, as appropriate).
- NR/NA - Not Reported / Not Available
- dry - Sample results reported on a Dry Weight Basis. Results and Reporting Limits have been corrected for Percent Dry Weight.
- wet - Sample results and reporting limits reported on a Wet Weight Basis (as received). Results with neither 'wet' nor 'dry' are reported on a Wet Weight Basis.
- RPD - RELATIVE PERCENT DIFFERENCE (RPDs calculated using Results, not Percent Recoveries).
- MRL - METHOD REPORTING LIMIT. Reporting Level at, or above, the lowest level standard of the Calibration Table.
- MDL* - METHOD DETECTION LIMIT. Reporting Level at, or above, the statistically derived limit based on 40CFR, Part 136, Appendix B. *MDLs are listed on the report only if the data has been evaluated below the MRL. Results between the MDL and MRL are reported as Estimated Results.
- Dil - Dilutions are calculated based on deviations from the standard dilution performed for an analysis, and may not represent the dilution found on the analytical raw data.
- Reporting Limits - Reporting limits (MDLs and MRLs) are adjusted based on variations in sample preparation amounts, analytical dilutions and percent solids, where applicable.
- Electronic Signature - Electronic Signature added in accordance with TestAmerica's *Electronic Reporting and Electronic Signatures Policy*. Application of electronic signature indicates that the report has been reviewed and approved for release by the laboratory. Electronic signature is intended to be the legally binding equivalent of a traditionally handwritten signature.

TestAmerica Portland



Christina Woodcock For Darrell Auvil, Project Manager

The results in this report apply to the samples analyzed in accordance with the chain of custody document. This analytical report shall not be reproduced except in full, without the written approval of the laboratory.

Canister Samples Chain of Custody Record

TestAmerica Laboratories, Inc. assumes no liability with respect to the collection and shipment of these samples.

PT6-0837

Client Contact Information		Project Manager: <u>Stephanie Bosze</u>					1 of 1 COCs																																														
Company: <u>Ash Creek</u>		Phone: <u>503.924.4704 x125</u>					Samples Collected By: <u>D. URQUHART</u>																																														
Address: <u>3015 SW First</u>		Email: <u>sbosze@ashcreekassociates.com</u>																																																			
City/State/Zip: <u>PORTLAND, OR 97201</u>		Site Contact:																																																			
Phone: <u>503.924.4704</u>		LAB Contact:																																																			
FAX:																																																					
Project Name: <u>NuStar Vancouver</u>		Analysis Turnaround Time																																																			
Site: <u>SVE IRAM</u>		Standard (Specify) <input checked="" type="checkbox"/>																																																			
PO #: <u>1126-09</u>		Rush (Specify)																																																			
Sample Identification	Sample Date(s)	Time Start	Time Stop	Canister Vacuum in Field, "Hg (Start)	Canister Vacuum in Field, "Hg (Stop)	Flow Controller ID	Canister ID	TO-15	TO-14A	TO-3	EPA 3C	EPA 25C	ASTM D-1946	Other (Please specify in notes section)	Sample Type	Indoor Air	Ambient Air	Soil Gas	Landfill Gas	Other (Please specify in notes section)																																	
<u>POSTCARBON-072910</u>	<u>7/29/10</u>	<u>929</u>	<u>931</u>	<u>29</u>	<u>5.5</u>	<u>-</u>	<u>E-21</u>	<u>X</u>																																													
<u>PRECARBON-072910</u>	<u>7/29/10</u>	<u>943</u>	<u>945</u>	<u>28</u>	<u>5.0</u>	<u>-</u>	<u>A-151</u>	<u>X</u>																																													
<table border="1"> <tr> <th colspan="4">Temperature (Fahrenheit)</th> </tr> <tr> <td></td> <td>Interior</td> <td>Ambient</td> <td></td> </tr> <tr> <td>Start</td> <td></td> <td></td> <td></td> </tr> <tr> <td>Stop</td> <td></td> <td></td> <td></td> </tr> <tr> <th colspan="4">Pressure (inches of Hg)</th> </tr> <tr> <td></td> <td>Interior</td> <td>Ambient</td> <td></td> </tr> <tr> <td>Start</td> <td></td> <td></td> <td></td> </tr> <tr> <td>Stop</td> <td></td> <td></td> <td></td> </tr> </table>																						Temperature (Fahrenheit)					Interior	Ambient		Start				Stop				Pressure (inches of Hg)					Interior	Ambient		Start				Stop			
Temperature (Fahrenheit)																																																					
	Interior	Ambient																																																			
Start																																																					
Stop																																																					
Pressure (inches of Hg)																																																					
	Interior	Ambient																																																			
Start																																																					
Stop																																																					
Special Instructions/QC Requirements & Comments:																																																					
Samples Shipped by: <u>Douglas Urquhart</u>		Date/Time: <u>7/29/10 1430</u>					Samples Received by: <u>Bosze</u>																																														
Samples Relinquished by: <u>Bosze</u>		Date/Time: <u>7/29/10 @ 18:10</u>					Received by: <u>TAP</u>																																														
Relinquished by:		Date/Time:					Received by:																																														

TestAmerica Portland
Sample Receiving Checklist

Work Order #: _____ Date/Time Received: 7/29/10 1810
 Client Name and Project: Ash Creek NvStar Vancouver

Time Zone:
 EDT/EST CDT/CST MDT/MST PDT/PST AK OTHER

Unpacking Checks:

Cooler #(s): N/A _____
 Temperatures: N/A _____
 Digi #1 Digi #2 IR Gun
 (Plastic Glass)

Temperature out of Range:

____ Not enough or No Ice
 ____ Ice Melted
 ____ W/in 4 Hrs of collection
 Other: _____

N/A Yes No

Initials: PS

- 1. If ESI client, were temp blanks received? If no, document on NOD.
- 2. Cooler Seals intact? (N/A if hand delivered) if no, document on NOD.
- 3. Chain of Custody present? If no, document on NOD.
- 4. Bottles received intact? If no, document on NOD.
- 5. Sample is not multiphasic? If no, document on NOD.
- 6. Proper Container and preservatives used? If no, document on NOD.
- 7. pH of all samples checked and meet requirements? If no, document on NOD.
- 8. Cyanide samples checked for sulfides and meet requirements? If no, notify PM.
- 9. HF Dilution required?
- 10. Sufficient volume provided for all analysis? If no, document on NOD and consult PM before proceeding.
- 11. Did chain of custody agree with samples received? If no, document on NOD.
- 12. Is the "Sampled by" section of the COC completed?
- 13. Were VOA/Oil Syringe samples without headspace?
- 14. Were VOA vials preserved? HCl Sodium Thiosulfate Ascorbic Acid
- 15. Did samples require preservation with sodium thiosulfate?
- 16. If yes to #15, was the residual chlorine test negative? If no, document on NOD.
- 17. Are dissolved/field filtered metals bottles sediment-free? If no, document on NOD.
- 18. Is sufficient volume provided for client requested MS/MSD or matrix duplicates? If no, document on NOD and contact PM before proceeding.
- 19. Are analyses with short holding times received in hold?
- 20. Was Standard Turn Around (TAT) requested?
- 21. Receipt date(s) < 48 hours past the collection date(s)? If no, notify PM.

TestAmerica Portland
Sample Receiving Checklist

Work Order #: PTG0887

Login Checks:

Initials: PS

N/A Yes No

22. Sufficient volume provided for all analysis? If no, document on NOD & contact PM.
23. Sufficient volume provided for client requested MS/MSD or matrix duplicates? If no, document on NOD and contact PM.
24. Did the chain of custody include "received by" and "relinquished by" signatures, dates and times?
25. Were special log in instructions read and followed?
26. Were tests logged checked against the COC?
27. Were rush notices printed and delivered?
28. Were short hold notices printed and delivered?
29. Were subcontract COCs printed?
30. Was HF dilution logged?

Labeling and Storage Checks:

Initials: PS

N/A Yes No

31. Were the subcontracted samples/containers put in Sx fridge?
32. Were sample bottles and COC double checked for dissolved/filtered metals?
33. Did the sample ID, Date, and Time from label match what was logged?
34. Were Foreign sample stickers affixed to each container and containers stored in foreign fridge?
35. Were HF stickers affixed to each container, and containers stored in Sx fridge?
36. Was an NOD for created for noted discrepancies and placed in folder?

Document any problems or discrepancies and the actions taken to resolve them on a Notice of Discrepancy form (NOD).

September 10, 2010

Kirsten White
Ash Creek Associates, Inc.
3015 SW First Avenue
Portland, OR 97201

RE: NuStar Vancouver

Enclosed are the results of analyses for samples received by the laboratory on 08/26/10 16:35.
The following list is a summary of the Work Orders contained in this report, generated on 09/10/10
16:21.

If you have any questions concerning this report, please feel free to contact me.

<u>Work Order</u>	<u>Project</u>	<u>ProjectNumber</u>
PTH0864	NuStar Vancouver	1126

TestAmerica Portland



Darrell Auvil, Project Manager

The results in this report apply to the samples analyzed in accordance with the chain of custody document. This analytical report shall not be reproduced except in full, without the written approval of the laboratory.

Ash Creek Associates, Inc.

3015 SW First Avenue
Portland, OR 97201

Project Name: **NuStar Vancouver**
Project Number: 1126
Project Manager: Kirsten White

Report Created:
09/10/10 16:21

ANALYTICAL REPORT FOR SAMPLES

Sample ID	Laboratory ID	Matrix	Date Sampled	Date Received
Post Carbon 082510	PTH0864-01	Air	08/25/10 12:35	08/26/10 16:35
Pre Carbon 082510	PTH0864-02	Air	08/25/10 12:42	08/26/10 16:35

TestAmerica Portland

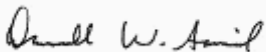

Darrell Auvil, Project Manager

The results in this report apply to the samples analyzed in accordance with the chain of custody document. This analytical report shall not be reproduced except in full, without the written approval of the laboratory.

Ash Creek Associates, Inc.

3015 SW First Avenue
Portland, OR 97201

Project Name: **NuStar Vancouver**

Project Number: 1126

Project Manager: Kirsten White

Report Created:

09/10/10 16:21

EPA TO15 (Med-level) - Volatile Organic Compounds by GC/MS

TestAmerica Los Angeles

Analyte	Method	Result	MDL*	MRL	Units	Dil	Batch	Prepared	Analyzed	Notes
PTH0864-01 (Post Carbon 082510)			Air				Sampled: 08/25/10 12:35			
Acetone	EPA TO15	ND	----	24	ug/m3	1x	10I0004	08/31/10 21:35	09/01/10 02:47	
Benzene	"	ND	----	9.6	"	"	"	"	"	
Benzyl chloride	"	ND	----	52	"	"	"	"	"	
Bromodichloromethane	"	ND	----	13	"	"	"	"	"	
Bromoform	"	ND	----	21	"	"	"	"	"	
Bromomethane	"	ND	----	16	"	"	"	"	"	
2-Butanone (MEK)	"	ND	----	29	"	"	"	"	"	
Carbon disulfide	"	ND	----	31	"	"	"	"	"	
Carbon tetrachloride	"	ND	----	13	"	"	"	"	"	
Chlorobenzene	"	ND	----	9.2	"	"	"	"	"	
Dibromochloromethane	"	ND	----	17	"	"	"	"	"	
Chloroethane	"	ND	----	11	"	"	"	"	"	
Chloroform	"	ND	----	9.8	"	"	"	"	"	
Chloromethane	"	ND	----	8.3	"	"	"	"	"	
1,2-Dibromoethane (EDB)	"	ND	----	15	"	"	"	"	"	
1,2-Dichlorobenzene	"	ND	----	12	"	"	"	"	"	
1,3-Dichlorobenzene	"	ND	----	24	"	"	"	"	"	
1,4-Dichlorobenzene	"	ND	----	24	"	"	"	"	"	
Dichlorodifluoromethane	"	ND	----	15	"	"	"	"	"	
1,1-Dichloroethane	"	ND	----	8.1	"	"	"	"	"	
1,2-Dichloroethane	"	ND	----	12	"	"	"	"	"	
cis-1,2-Dichloroethene	"	ND	----	7.9	"	"	"	"	"	
trans-1,2-Dichloroethene	"	ND	----	7.9	"	"	"	"	"	
1,1-Dichloroethene	"	ND	----	7.9	"	"	"	"	"	
1,2-Dichloropropane	"	ND	----	14	"	"	"	"	"	
cis-1,3-Dichloropropene	"	ND	----	9.1	"	"	"	"	"	
trans-1,3-Dichloropropene	"	ND	----	9.1	"	"	"	"	"	
1,2-Dichloro-1,1,2,2-tetrafluoroethane	"	ND	----	14	"	"	"	"	"	
Ethylbenzene	"	ND	----	8.7	"	"	"	"	"	
4-Ethyltoluene	"	ND	----	9.8	"	"	"	"	"	
Hexachlorobutadiene	"	ND	----	43	"	"	"	"	"	
2-Hexanone	"	ND	----	41	"	"	"	"	"	
Methylene chloride	"	ND	----	6.9	"	"	"	"	"	
4-Methyl-2-pentanone (MIBK)	"	ND	----	41	"	"	"	"	"	
Styrene	"	ND	----	8.5	"	"	"	"	"	

TestAmerica Portland

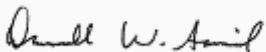

Darrell Auvil, Project Manager

The results in this report apply to the samples analyzed in accordance with the chain of custody document. This analytical report shall not be reproduced except in full, without the written approval of the laboratory.

Ash Creek Associates, Inc.

3015 SW First Avenue
Portland, OR 97201

Project Name: **NuStar Vancouver**

Project Number: 1126

Project Manager: Kirsten White

Report Created:

09/10/10 16:21

EPA TO15 (Med-level) - Volatile Organic Compounds by GC/MS

TestAmerica Los Angeles

Analyte	Method	Result	MDL*	MRL	Units	Dil	Batch	Prepared	Analyzed	Notes
PTH0864-01 (Post Carbon 082510)				Air		Sampled: 08/25/10 12:35				
1,1,2,2-Tetrachloroethane	EPA TO15	ND	----	14	ug/m3	1x	1010004	08/31/10 21:35	09/01/10 02:47	
Tetrachloroethene	"	ND	----	14	"	"	"	"	"	"
Toluene	"	ND	----	7.5	"	"	"	"	"	"
1,2,4-Trichlorobenzene	"	ND	----	37	"	"	"	"	"	"
1,1,1-Trichloroethane	"	ND	----	11	"	"	"	"	"	"
1,1,2-Trichloroethane	"	ND	----	11	"	"	"	"	"	"
Trichloroethene	"	ND	----	11	"	"	"	"	"	"
Trichlorofluoromethane	"	ND	----	11	"	"	"	"	"	"
1,1,2-Trichloro-1,2,2-trifluoroethane	"	ND	----	15	"	"	"	"	"	"
1,2,4-Trimethylbenzene	"	ND	----	15	"	"	"	"	"	"
1,3,5-Trimethylbenzene	"	ND	----	20	"	"	"	"	"	"
Vinyl acetate	"	ND	----	70	"	"	"	"	"	"
Vinyl chloride	"	ND	----	10	"	"	"	"	"	"
m,p-Xylene	"	ND	----	17	"	"	"	"	"	"
o-Xylene	"	ND	----	8.7	"	"	"	"	"	"
Xylenes, total	"	ND	----	8.7	"	"	"	"	"	"
<i>Surrogate(s): 4-Bromofluorobenzene</i>				111%		70 - 130 %	"			"
<i>1,2-Dichloroethane-d4</i>				119%		70 - 130 %	"			"
<i>Toluene-d8</i>				114%		70 - 130 %	"			"

PTH0864-02 (Pre Carbon 082510)

Air

Sampled: 08/25/10 12:42

Acetone	EPA TO15	ND	480	1200	ug/m3	50.8x	1010017	08/30/10 18:40	08/31/10 00:50	
Benzene	"	ND	240	490	"	"	"	"	"	
Benzyl chloride	"	ND	530	2600	"	"	"	"	"	
Bromodichloromethane	"	ND	340	680	"	"	"	"	"	
Bromoform	"	ND	260	1100	"	"	"	"	"	
Bromomethane	"	ND	390	790	"	"	"	"	"	
2-Butanone (MEK)	"	ND	450	1500	"	"	"	"	"	
Carbon disulfide	"	ND	630	1600	"	"	"	"	"	
Carbon tetrachloride	"	ND	320	640	"	"	"	"	"	
Chlorobenzene	"	ND	120	470	"	"	"	"	"	
Dibromochloromethane	"	ND	430	870	"	"	"	"	"	
Chloroethane	"	ND	200	540	"	"	"	"	"	
Chloroform	"	ND	250	500	"	"	"	"	"	
Chloromethane	"	ND	210	420	"	"	"	"	"	
1,2-Dibromoethane (EDB)	"	ND	390	780	"	"	"	"	"	

TestAmerica Portland

The results in this report apply to the samples analyzed in accordance with the chain of custody document. This analytical report shall not be reproduced except in full, without the written approval of the laboratory.

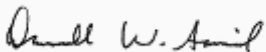

Darrell Auvil, Project Manager

Ash Creek Associates, Inc.

3015 SW First Avenue
Portland, OR 97201

Project Name: **NuStar Vancouver**

Project Number: 1126

Project Manager: Kirsten White

Report Created:

09/10/10 16:21

EPA TO15 (Med-level) - Volatile Organic Compounds by GC/MS

TestAmerica Los Angeles

Analyte	Method	Result	MDL*	MRL	Units	Dil	Batch	Prepared	Analyzed	Notes
PTH0864-02 (Pre Carbon 082510)				Air		Sampled: 08/25/10 12:42				
1,2-Dichlorobenzene	EPA TO15	ND	280	610	ug/m3	50.8x	1010017	08/30/10 18:40	08/31/10 00:50	
1,3-Dichlorobenzene	"	ND	240	1200	"	"	"	"	"	
1,4-Dichlorobenzene	"	ND	310	1200	"	"	"	"	"	
Dichlorodifluoromethane	"	ND	250	750	"	"	"	"	"	
1,1-Dichloroethane	"	ND	210	410	"	"	"	"	"	
1,2-Dichloroethane	"	ND	310	620	"	"	"	"	"	
cis-1,2-Dichloroethene	"	200	160	400	"	"	"	"	"	J
trans-1,2-Dichloroethene	"	ND	200	400	"	"	"	"	"	
1,1-Dichloroethene	"	ND	200	400	"	"	"	"	"	
1,2-Dichloropropane	"	ND	350	700	"	"	"	"	"	
cis-1,3-Dichloropropene	"	ND	230	460	"	"	"	"	"	
trans-1,3-Dichloropropene	"	ND	230	460	"	"	"	"	"	
1,2-Dichloro-1,1,2,2-tetrafluoroethane	"	ND	360	710	"	"	"	"	"	
Ethylbenzene	"	ND	220	440	"	"	"	"	"	
4-Ethyltoluene	"	ND	250	500	"	"	"	"	"	
Hexachlorobutadiene	"	ND	810	2200	"	"	"	"	"	
2-Hexanone	"	ND	420	2100	"	"	"	"	"	
Methylene chloride	"	ND	180	350	"	"	"	"	"	
4-Methyl-2-pentanone (MIBK)	"	ND	420	2100	"	"	"	"	"	
Styrene	"	ND	220	430	"	"	"	"	"	
1,1,2,2-Tetrachloroethane	"	ND	350	700	"	"	"	"	"	
Tetrachloroethene	"	55000	340	690	"	"	"	"	"	
Toluene	"	ND	190	380	"	"	"	"	"	
1,2,4-Trichlorobenzene	"	ND	940	1900	"	"	"	"	"	
1,1,1-Trichloroethane	"	ND	280	550	"	"	"	"	"	
1,1,2-Trichloroethane	"	ND	280	550	"	"	"	"	"	
Trichloroethene	"	1800	270	550	"	"	"	"	"	
Trichlorofluoromethane	"	ND	290	570	"	"	"	"	"	
1,1,2-Trichloro-1,2,2-trifluoroethane	"	ND	390	780	"	"	"	"	"	
1,2,4-Trimethylbenzene	"	ND	320	750	"	"	"	"	"	
1,3,5-Trimethylbenzene	"	ND	500	1000	"	"	"	"	"	
Vinyl acetate	"	ND	1800	3600	"	"	"	"	"	
Vinyl chloride	"	ND	260	520	"	"	"	"	"	
m,p-Xylene	"	ND	440	880	"	"	"	"	"	
o-Xylene	"	ND	220	440	"	"	"	"	"	

TestAmerica Portland



Darrell Auvil, Project Manager

The results in this report apply to the samples analyzed in accordance with the chain of custody document. This analytical report shall not be reproduced except in full, without the written approval of the laboratory.

Ash Creek Associates, Inc.	Project Name: NuStar Vancouver	Report Created:
3015 SW First Avenue	Project Number: 1126	09/10/10 16:21
Portland, OR 97201	Project Manager: Kirsten White	

EPA TO15 (Med-level) - Volatile Organic Compounds by GC/MS
 TestAmerica Los Angeles

Analyte	Method	Result	MDL*	MRL	Units	Dil	Batch	Prepared	Analyzed	Notes
PTH0864-02 (Pre Carbon 082510)										
			Air					Sampled: 08/25/10 12:42		
Xylenes, total	EPA TO15	ND	220	440	ug/m3	50.8x	10I0017	08/30/10 18:40	08/31/10 00:50	
Surrogate(s):	4-Bromofluorobenzene			100%		70 - 130 %	1x			"
	1,2-Dichloroethane-d4			108%		70 - 130 %	"			"
	Toluene-d8			93%		70 - 130 %	"			"

TestAmerica Portland



Darrell Auvil, Project Manager

The results in this report apply to the samples analyzed in accordance with the chain of custody document. This analytical report shall not be reproduced except in full, without the written approval of the laboratory.

Ash Creek Associates, Inc.

3015 SW First Avenue
Portland, OR 97201

Project Name: **NuStar Vancouver**

Project Number: 1126

Project Manager: Kirsten White

Report Created:

09/10/10 16:21

EPA TO15 (Med-level) - Volatile Organic Compounds by GC/MS - Laboratory Quality Control Results

TestAmerica Los Angeles

QC Batch: 10I0004

Air Preparation Method: METHOD-MSMED

Analyte	Method	Result	MDL*	MRL	Units	Dil	Source Result	Spike Amt	% REC	(Limits)	% RPD	(Limits)	Analyzed	Notes
Blank (10I0004-BLK1)													Extracted: 08/31/10 15:40	
Acetone	EPA TO15	ND	---	24	ug/m3	1x	--	--	--	--	--	--	08/31/10 20:59	
Benzene	"	ND	---	9.6	"	"	--	--	--	--	--	--	"	
Benzyl chloride	"	ND	---	52	"	"	--	--	--	--	--	--	"	
Bromodichloromethane	"	ND	---	13	"	"	--	--	--	--	--	--	"	
Bromoform	"	ND	---	21	"	"	--	--	--	--	--	--	"	
Bromomethane	"	ND	---	16	"	"	--	--	--	--	--	--	"	
2-Butanone (MEK)	"	ND	---	29	"	"	--	--	--	--	--	--	"	
Carbon disulfide	"	ND	---	31	"	"	--	--	--	--	--	--	"	
Carbon tetrachloride	"	ND	---	13	"	"	--	--	--	--	--	--	"	
Chlorobenzene	"	ND	---	9.2	"	"	--	--	--	--	--	--	"	
Dibromochloromethane	"	ND	---	17	"	"	--	--	--	--	--	--	"	
Chloroethane	"	ND	---	11	"	"	--	--	--	--	--	--	"	
Chloroform	"	ND	---	9.8	"	"	--	--	--	--	--	--	"	
Chloromethane	"	ND	---	8.3	"	"	--	--	--	--	--	--	"	
1,2-Dibromoethane (EDB)	"	ND	---	15	"	"	--	--	--	--	--	--	"	
1,2-Dichlorobenzene	"	ND	---	12	"	"	--	--	--	--	--	--	"	
1,3-Dichlorobenzene	"	ND	---	24	"	"	--	--	--	--	--	--	"	
1,4-Dichlorobenzene	"	ND	---	24	"	"	--	--	--	--	--	--	"	
Dichlorodifluoromethane	"	ND	---	15	"	"	--	--	--	--	--	--	"	
1,1-Dichloroethane	"	ND	---	8.1	"	"	--	--	--	--	--	--	"	
1,2-Dichloroethane	"	ND	---	12	"	"	--	--	--	--	--	--	"	
cis-1,2-Dichloroethene	"	ND	---	7.9	"	"	--	--	--	--	--	--	"	
trans-1,2-Dichloroethene	"	ND	---	7.9	"	"	--	--	--	--	--	--	"	
1,1-Dichloroethene	"	ND	---	7.9	"	"	--	--	--	--	--	--	"	
1,2-Dichloropropane	"	ND	---	14	"	"	--	--	--	--	--	--	"	
cis-1,3-Dichloropropene	"	ND	---	9.1	"	"	--	--	--	--	--	--	"	
trans-1,3-Dichloropropene	"	ND	---	9.1	"	"	--	--	--	--	--	--	"	
1,2-Dichloro-1,1,2,2-tetrafluoroethane	"	ND	---	14	"	"	--	--	--	--	--	--	"	
Ethylbenzene	"	ND	---	8.7	"	"	--	--	--	--	--	--	"	
4-Ethyltoluene	"	ND	---	9.8	"	"	--	--	--	--	--	--	"	
Hexachlorobutadiene	"	ND	---	43	"	"	--	--	--	--	--	--	"	
2-Hexanone	"	ND	---	41	"	"	--	--	--	--	--	--	"	
Methylene chloride	"	ND	---	6.9	"	"	--	--	--	--	--	--	"	
4-Methyl-2-pentanone (MIBK)	"	ND	---	41	"	"	--	--	--	--	--	--	"	
Styrene	"	ND	---	8.5	"	"	--	--	--	--	--	--	"	
1,1,2,2-Tetrachloroethane	"	ND	---	14	"	"	--	--	--	--	--	--	"	
Tetrachloroethene	"	ND	---	14	"	"	--	--	--	--	--	--	"	
Toluene	"	ND	---	7.5	"	"	--	--	--	--	--	--	"	
1,2,4-Trichlorobenzene	"	ND	---	37	"	"	--	--	--	--	--	--	"	

TestAmerica Portland



Darrell Auvil, Project Manager

The results in this report apply to the samples analyzed in accordance with the chain of custody document. This analytical report shall not be reproduced except in full, without the written approval of the laboratory.

Ash Creek Associates, Inc.

3015 SW First Avenue
Portland, OR 97201

Project Name: **NuStar Vancouver**

Project Number: 1126

Project Manager: Kirsten White

Report Created:

09/10/10 16:21

EPA TO15 (Med-level) - Volatile Organic Compounds by GC/MS - Laboratory Quality Control Results

TestAmerica Los Angeles

QC Batch: 10I0004

Air Preparation Method: METHOD-MSMED

Analyte	Method	Result	MDL*	MRL	Units	Dil	Source Result	Spike Amt	% REC	(Limits)	% RPD	(Limits)	Analyzed	Notes
---------	--------	--------	------	-----	-------	-----	---------------	-----------	-------	----------	-------	----------	----------	-------

Blank (10I0004-BLK1)

Extracted: 08/31/10 15:40

1,1,1-Trichloroethane	EPA TO15	ND	---	11	ug/m3	1x	--	--	--	--	--	--	08/31/10 20:59	
1,1,2-Trichloroethane	"	ND	---	11	"	"	--	--	--	--	--	--	"	
Trichloroethene	"	ND	---	11	"	"	--	--	--	--	--	--	"	
Trichlorofluoromethane	"	ND	---	11	"	"	--	--	--	--	--	--	"	
1,1,2-Trichloro-1,2,2-trifluoroethane	"	ND	---	15	"	"	--	--	--	--	--	--	"	
1,2,4-Trimethylbenzene	"	ND	---	15	"	"	--	--	--	--	--	--	"	
1,3,5-Trimethylbenzene	"	ND	---	20	"	"	--	--	--	--	--	--	"	
Vinyl acetate	"	ND	---	70	"	"	--	--	--	--	--	--	"	
Vinyl chloride	"	ND	---	10	"	"	--	--	--	--	--	--	"	
m,p-Xylene	"	ND	---	17	"	"	--	--	--	--	--	--	"	
o-Xylene	"	ND	---	8.7	"	"	--	--	--	--	--	--	"	
Xylenes, total	"	ND	---	8.7	"	"	--	--	--	--	--	--	"	

Surrogate(s): 4-Bromofluorobenzene	Recovery: 115%	Limits: 70-130%	"	08/31/10 20:59
1,2-Dichloroethane-d4	111%	70-130%	"	"
Toluene-d8	95%	70-130%	"	"

LCS (10I0004-BS1)

Extracted: 08/31/10 15:40

Acetone	EPA TO15	87.8	---	24	ug/m3	1x	--	125	70%	(70-130)	--	--	08/31/10 19:06	
Benzene	"	137	---	9.6	"	"	--	169	81%	"	--	--	"	
Bromodichloromethane	"	308	---	13	"	"	--	335	92%	"	--	--	"	
Bromomethane	"	202	---	16	"	"	--	194	104%	"	--	--	"	
2-Butanone (MEK)	"	136	---	29	"	"	--	164	83%	"	--	--	"	
Carbon disulfide	"	154	---	31	"	"	--	156	99%	"	--	--	"	
Chlorobenzene	"	194	---	9.2	"	"	--	244	79%	"	--	--	"	
1,4-Dichlorobenzene	"	282	---	24	"	"	--	301	94%	"	--	--	"	
cis-1,2-Dichloroethene	"	186	---	7.9	"	"	--	212	88%	"	--	--	"	
Hexachlorobutadiene	"	522	---	43	"	"	--	491	106%	"	--	--	"	
1,1,2-Trichloroethane	"	239	---	11	"	"	--	273	88%	"	--	--	"	
Trichloroethene	"	235	---	11	"	"	--	269	87%	"	--	--	"	
1,2,4-Trimethylbenzene	"	262	---	15	"	"	--	246	107%	"	--	--	"	
Vinyl chloride	"	117	---	10	"	"	--	128	92%	"	--	--	"	
m,p-Xylene	"	399	---	17	"	"	--	434	92%	"	--	--	"	
o-Xylene	"	188	---	8.7	"	"	--	228	82%	"	--	--	"	

Surrogate(s): 4-Bromofluorobenzene	Recovery: 115%	Limits: 70-130%	"	08/31/10 19:06
1,2-Dichloroethane-d4	112%	70-130%	"	"
Toluene-d8	97%	70-130%	"	"

TestAmerica Portland

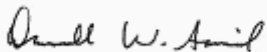

Darrell Auvil, Project Manager

The results in this report apply to the samples analyzed in accordance with the chain of custody document. This analytical report shall not be reproduced except in full, without the written approval of the laboratory.

Ash Creek Associates, Inc.	Project Name: NuStar Vancouver	Report Created:
3015 SW First Avenue	Project Number: 1126	09/10/10 16:21
Portland, OR 97201	Project Manager: Kirsten White	

EPA TO15 (Med-level) - Volatile Organic Compounds by GC/MS - Laboratory Quality Control Results
TestAmerica Los Angeles

QC Batch: 10I0004 **Air Preparation Method: METHOD-MSMED**

Analyte	Method	Result	MDL*	MRL	Units	Dil	Source Result	Spike Amt	% REC	(Limits)	% RPD	(Limits)	Analyzed	Notes
LCS Dup (10I0004-BSD1)										Extracted: 08/31/10 15:40				
Acetone	EPA TO15	92.9	---	24	ug/m3	1x	--	125	74%	(70-130)	6%	(25)	08/31/10 19:44	
Benzene	"	135	---	9.6	"	"	--	169	79%	"	2%	"	"	
Bromodichloromethane	"	298	---	13	"	"	--	335	89%	"	3%	"	"	
Bromomethane	"	196	---	16	"	"	--	194	101%	"	3%	"	"	
2-Butanone (MEK)	"	138	---	29	"	"	--	164	84%	"	1%	"	"	
Carbon disulfide	"	148	---	31	"	"	--	156	95%	"	4%	"	"	
Chlorobenzene	"	191	---	9.2	"	"	--	244	78%	"	1%	"	"	
1,4-Dichlorobenzene	"	278	---	24	"	"	--	301	92%	"	1%	"	"	
cis-1,2-Dichloroethene	"	183	---	7.9	"	"	--	212	86%	"	2%	"	"	
Hexachlorobutadiene	"	522	---	43	"	"	--	491	106%	"	0.008%	"	"	
1,1,2-Trichloroethane	"	230	---	11	"	"	--	273	84%	"	4%	"	"	
Trichloroethene	"	228	---	11	"	"	--	269	85%	"	3%	"	"	
1,2,4-Trimethylbenzene	"	255	---	15	"	"	--	246	104%	"	3%	"	"	
Vinyl chloride	"	103	---	10	"	"	--	128	80%	"	13%	"	"	
m,p-Xylene	"	394	---	17	"	"	--	434	91%	"	1%	"	"	
o-Xylene	"	187	---	8.7	"	"	--	228	82%	"	0.3%	"	"	
<i>Surrogate(s): 4-Bromofluorobenzene</i>		<i>Recovery: 116%</i>		<i>Limits: 70-130%</i>		<i>"</i>				<i>08/31/10 19:44</i>				
<i>1,2-Dichloroethane-d4</i>		<i>107%</i>		<i>70-130%</i>		<i>"</i>				<i>"</i>				
<i>Toluene-d8</i>		<i>95%</i>		<i>70-130%</i>		<i>"</i>				<i>"</i>				

TestAmerica Portland



Darrell Auvil, Project Manager

The results in this report apply to the samples analyzed in accordance with the chain of custody document. This analytical report shall not be reproduced except in full, without the written approval of the laboratory.

Ash Creek Associates, Inc.

3015 SW First Avenue
Portland, OR 97201

Project Name: **NuStar Vancouver**

Project Number: 1126

Project Manager: Kirsten White

Report Created:

09/10/10 16:21

EPA TO15 (Med-level) - Volatile Organic Compounds by GC/MS - Laboratory Quality Control Results

TestAmerica Los Angeles

QC Batch: 10I0017

Air Preparation Method: METHOD-MSLOW

Analyte	Method	Result	MDL*	MRL	Units	Dil	Source Result	Spike Amt	% REC	(Limits)	% RPD	(Limits)	Analyzed	Notes
Blank (10I0017-BLK1)													Extracted: 08/30/10 15:44	
Acetone	EPA TO15	ND	9.5	24	ug/m3	1x	--	--	--	--	--	--	08/30/10 19:10	
Benzene	"	ND	4.8	9.6	"	"	--	--	--	--	--	--	"	
Benzyl chloride	"	ND	10	52	"	"	--	--	--	--	--	--	"	
Bromodichloromethane	"	ND	6.7	13	"	"	--	--	--	--	--	--	"	
Bromoform	"	ND	5.2	21	"	"	--	--	--	--	--	--	"	
Bromomethane	"	ND	7.8	16	"	"	--	--	--	--	--	--	"	
2-Butanone (MEK)	"	ND	8.8	29	"	"	--	--	--	--	--	--	"	
Carbon disulfide	"	ND	12	31	"	"	--	--	--	--	--	--	"	
Carbon tetrachloride	"	ND	6.3	13	"	"	--	--	--	--	--	--	"	
Chlorobenzene	"	ND	2.3	9.2	"	"	--	--	--	--	--	--	"	
Dibromochloromethane	"	ND	8.5	17	"	"	--	--	--	--	--	--	"	
Chloroethane	"	ND	4.0	11	"	"	--	--	--	--	--	--	"	
Chloroform	"	ND	4.9	9.8	"	"	--	--	--	--	--	--	"	
Chloromethane	"	ND	4.1	8.3	"	"	--	--	--	--	--	--	"	
1,2-Dibromoethane (EDB)	"	ND	7.7	15	"	"	--	--	--	--	--	--	"	
1,2-Dichlorobenzene	"	ND	5.4	12	"	"	--	--	--	--	--	--	"	
1,3-Dichlorobenzene	"	ND	4.8	24	"	"	--	--	--	--	--	--	"	
1,4-Dichlorobenzene	"	ND	6.0	24	"	"	--	--	--	--	--	--	"	
Dichlorodifluoromethane	"	ND	4.9	15	"	"	--	--	--	--	--	--	"	
1,1-Dichloroethane	"	ND	4.0	8.1	"	"	--	--	--	--	--	--	"	
1,2-Dichloroethane	"	ND	6.1	12	"	"	--	--	--	--	--	--	"	
cis-1,2-Dichloroethene	"	ND	3.2	7.9	"	"	--	--	--	--	--	--	"	
trans-1,2-Dichloroethene	"	ND	4.0	7.9	"	"	--	--	--	--	--	--	"	
1,1-Dichloroethene	"	ND	4.0	7.9	"	"	--	--	--	--	--	--	"	
1,2-Dichloropropane	"	ND	6.9	14	"	"	--	--	--	--	--	--	"	
cis-1,3-Dichloropropene	"	ND	4.5	9.1	"	"	--	--	--	--	--	--	"	
trans-1,3-Dichloropropene	"	ND	4.5	9.1	"	"	--	--	--	--	--	--	"	
1,2-Dichloro-1,1,2,2-tetrafluoroethane	"	ND	7.0	14	"	"	--	--	--	--	--	--	"	
Ethylbenzene	"	ND	4.3	8.7	"	"	--	--	--	--	--	--	"	
4-Ethyltoluene	"	ND	4.9	9.8	"	"	--	--	--	--	--	--	"	
Hexachlorobutadiene	"	ND	16	43	"	"	--	--	--	--	--	--	"	
2-Hexanone	"	ND	8.2	41	"	"	--	--	--	--	--	--	"	
Methylene chloride	"	ND	3.5	6.9	"	"	--	--	--	--	--	--	"	
4-Methyl-2-pentanone (MIBK)	"	ND	8.2	41	"	"	--	--	--	--	--	--	"	
Styrene	"	ND	4.3	8.5	"	"	--	--	--	--	--	--	"	
1,1,2,2-Tetrachloroethane	"	ND	6.9	14	"	"	--	--	--	--	--	--	"	
Tetrachloroethene	"	ND	6.8	14	"	"	--	--	--	--	--	--	"	
Toluene	"	ND	3.8	7.5	"	"	--	--	--	--	--	--	"	
1,2,4-Trichlorobenzene	"	ND	19	37	"	"	--	--	--	--	--	--	"	

TestAmerica Portland



Darrell Auvil, Project Manager

The results in this report apply to the samples analyzed in accordance with the chain of custody document. This analytical report shall not be reproduced except in full, without the written approval of the laboratory.

Ash Creek Associates, Inc.

3015 SW First Avenue
Portland, OR 97201

Project Name: **NuStar Vancouver**

Project Number: 1126

Project Manager: Kirsten White

Report Created:

09/10/10 16:21

EPA TO15 (Med-level) - Volatile Organic Compounds by GC/MS - Laboratory Quality Control Results

TestAmerica Los Angeles

QC Batch: 10I0017

Air Preparation Method: METHOD-MSLOW

Analyte	Method	Result	MDL*	MRL	Units	Dil	Source Result	Spike Amt	% REC	(Limits)	% RPD	(Limits)	Analyzed	Notes
---------	--------	--------	------	-----	-------	-----	---------------	-----------	-------	----------	-------	----------	----------	-------

Blank (10I0017-BLK1)

Extracted: 08/30/10 15:44

1,1,1-Trichloroethane	EPA TO15	ND	5.5	11	ug/m3	1x	--	--	--	--	--	--	08/30/10 19:10	
1,1,2-Trichloroethane	"	ND	5.5	11	"	"	--	--	--	--	--	--	"	
Trichloroethene	"	ND	5.4	11	"	"	--	--	--	--	--	--	"	
Trichlorofluoromethane	"	ND	5.6	11	"	"	--	--	--	--	--	--	"	
1,1,2-Trichloro-1,2,2-trifluoroethane	"	ND	7.7	15	"	"	--	--	--	--	--	--	"	
1,2,4-Trimethylbenzene	"	ND	6.4	15	"	"	--	--	--	--	--	--	"	
1,3,5-Trimethylbenzene	"	ND	9.8	20	"	"	--	--	--	--	--	--	"	
Vinyl acetate	"	ND	35	70	"	"	--	--	--	--	--	--	"	
Vinyl chloride	"	ND	5.1	10	"	"	--	--	--	--	--	--	"	
m,p-Xylene	"	ND	8.7	17	"	"	--	--	--	--	--	--	"	
o-Xylene	"	ND	4.3	8.7	"	"	--	--	--	--	--	--	"	
Xylenes, total	"	ND	4.3	8.7	"	"	--	--	--	--	--	--	"	

Surrogate(s): 4-Bromofluorobenzene	Recovery: 103%	Limits: 70-130%	"	08/30/10 19:10
1,2-Dichloroethane-d4	101%	70-130%	"	"
Toluene-d8	112%	70-130%	"	"

LCS (10I0017-BS1)

Extracted: 08/30/10 15:44

Acetone	EPA TO15	88.1	9.5	24	ug/m3	1x	--	125	71%	(70-130)	--	--	08/30/10 17:37	
Benzene	"	137	4.8	9.6	"	"	--	169	81%	"	--	--	"	
Bromodichloromethane	"	310	6.7	13	"	"	--	335	93%	"	--	--	"	
Bromomethane	"	183	7.8	16	"	"	--	194	94%	"	--	--	"	
2-Butanone (MEK)	"	126	8.8	29	"	"	--	164	77%	"	--	--	"	
Carbon disulfide	"	157	12	31	"	"	--	156	101%	"	--	--	"	
Chlorobenzene	"	200	2.3	9.2	"	"	--	244	82%	"	--	--	"	
1,4-Dichlorobenzene	"	292	6.0	24	"	"	--	301	97%	"	--	--	"	
cis-1,2-Dichloroethene	"	177	3.2	7.9	"	"	--	212	84%	"	--	--	"	
Hexachlorobutadiene	"	530	16	43	"	"	--	491	108%	"	--	--	"	
1,1,2-Trichloroethane	"	235	5.5	11	"	"	--	273	86%	"	--	--	"	
Trichloroethene	"	239	5.4	11	"	"	--	269	89%	"	--	--	"	
1,2,4-Trimethylbenzene	"	247	6.4	15	"	"	--	246	100%	"	--	--	"	
Vinyl chloride	"	115	5.1	10	"	"	--	128	90%	"	--	--	"	
m,p-Xylene	"	402	8.7	17	"	"	--	434	93%	"	--	--	"	
o-Xylene	"	188	4.3	8.7	"	"	--	228	82%	"	--	--	"	

Surrogate(s): 4-Bromofluorobenzene	Recovery: 107%	Limits: 70-130%	"	08/30/10 17:37
1,2-Dichloroethane-d4	99%	70-130%	"	"
Toluene-d8	93%	70-130%	"	"

TestAmerica Portland

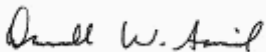

Darrell Auvil, Project Manager

The results in this report apply to the samples analyzed in accordance with the chain of custody document. This analytical report shall not be reproduced except in full, without the written approval of the laboratory.

Ash Creek Associates, Inc.	Project Name: NuStar Vancouver	Report Created:
3015 SW First Avenue	Project Number: 1126	09/10/10 16:21
Portland, OR 97201	Project Manager: Kirsten White	

EPA TO15 (Med-level) - Volatile Organic Compounds by GC/MS - Laboratory Quality Control Results
 TestAmerica Los Angeles

QC Batch: 10I0017 **Air Preparation Method: METHOD-MSLOW**

Analyte	Method	Result	MDL*	MRL	Units	Dil	Source Result	Spike Amt	% REC	(Limits)	% RPD	(Limits)	Analyzed	Notes
LCS Dup (10I0017-BSD1)										Extracted: 08/30/10 15:44				
Acetone	EPA TO15	81.0	9.5	24	ug/m3	1x	--	125	65%	(70-130)	8%	(25)	08/30/10 18:15	L5
Benzene	"	135	4.8	9.6	"	"	--	169	80%	"	1%	"	"	"
Bromodichloromethane	"	306	6.7	13	"	"	--	335	91%	"	1%	"	"	"
Bromomethane	"	186	7.8	16	"	"	--	194	96%	"	2%	"	"	"
2-Butanone (MEK)	"	121	8.8	29	"	"	--	164	74%	"	4%	"	"	"
Carbon disulfide	"	153	12	31	"	"	--	156	98%	"	3%	"	"	"
Chlorobenzene	"	198	2.3	9.2	"	"	--	244	81%	"	1%	"	"	"
1,4-Dichlorobenzene	"	300	6.0	24	"	"	--	301	100%	"	3%	"	"	"
cis-1,2-Dichloroethene	"	176	3.2	7.9	"	"	--	212	83%	"	0.7%	"	"	"
Hexachlorobutadiene	"	532	16	43	"	"	--	491	108%	"	0.4%	"	"	"
1,1,2-Trichloroethane	"	231	5.5	11	"	"	--	273	85%	"	2%	"	"	"
Trichloroethene	"	242	5.4	11	"	"	--	269	90%	"	1%	"	"	"
1,2,4-Trimethylbenzene	"	266	6.4	15	"	"	--	246	108%	"	8%	"	"	"
Vinyl chloride	"	114	5.1	10	"	"	--	128	89%	"	1%	"	"	"
m,p-Xylene	"	402	8.7	17	"	"	--	434	93%	"	0.04%	"	"	"
o-Xylene	"	194	4.3	8.7	"	"	--	228	85%	"	3%	"	"	"
<i>Surrogate(s): 4-Bromofluorobenzene</i>		<i>Recovery: 108%</i>		<i>Limits: 70-130%</i>		<i>"</i>				<i>08/30/10 18:15</i>				
<i>1,2-Dichloroethane-d4</i>		<i>101%</i>		<i>70-130%</i>		<i>"</i>				<i>"</i>				
<i>Toluene-d8</i>		<i>94%</i>		<i>70-130%</i>		<i>"</i>				<i>"</i>				

TestAmerica Portland



Darrell Auvil, Project Manager

The results in this report apply to the samples analyzed in accordance with the chain of custody document. This analytical report shall not be reproduced except in full, without the written approval of the laboratory.

Ash Creek Associates, Inc. 3015 SW First Avenue Portland, OR 97201	Project Name:	NuStar Vancouver	Report Created:
	Project Number:	1126	09/10/10 16:21
	Project Manager:	Kirsten White	

Notes and Definitions

Report Specific Notes:

- J - Estimated value. Analyte detected at a level less than the Reporting Limit (RL) and greater than or equal to the Method Detection Limit (MDL). The user of this data should be aware that this data is of limited reliability.
- L5 - Analyte recovery outside of specified criteria. Individual analyte criteria exceedences allowed for multi-component analyses without disqualification of data per NELAC Standard, DOD QSM and/or AFCEE QAPP.

Laboratory Reporting Conventions:

- DET - Analyte DETECTED at or above the Reporting Limit. Qualitative Analyses only.
- ND - Analyte NOT DETECTED at or above the reporting limit (MDL or MRL, as appropriate).
- NR/NA - Not Reported / Not Available
- dry - Sample results reported on a Dry Weight Basis. Results and Reporting Limits have been corrected for Percent Dry Weight.
- wet - Sample results and reporting limits reported on a Wet Weight Basis (as received). Results with neither 'wet' nor 'dry' are reported on a Wet Weight Basis.
- RPD - RELATIVE PERCENT DIFFERENCE (RPDs calculated using Results, not Percent Recoveries).
- MRL - METHOD REPORTING LIMIT. Reporting Level at, or above, the lowest level standard of the Calibration Table.
- MDL* - METHOD DETECTION LIMIT. Reporting Level at, or above, the statistically derived limit based on 40CFR, Part 136, Appendix B. *MDLs are listed on the report only if the data has been evaluated below the MRL. Results between the MDL and MRL are reported as Estimated Results.
- Dil - Dilutions are calculated based on deviations from the standard dilution performed for an analysis, and may not represent the dilution found on the analytical raw data.
- Reporting Limits - Reporting limits (MDLs and MRLs) are adjusted based on variations in sample preparation amounts, analytical dilutions and percent solids, where applicable.
- Electronic Signature - Electronic Signature added in accordance with TestAmerica's *Electronic Reporting and Electronic Signatures Policy*. Application of electronic signature indicates that the report has been reviewed and approved for release by the laboratory. Electronic signature is intended to be the legally binding equivalent of a traditionally handwritten signature.

TestAmerica Portland



Darrell Auvil, Project Manager

The results in this report apply to the samples analyzed in accordance with the chain of custody document. This analytical report shall not be reproduced except in full, without the written approval of the laboratory.

CERTIFICATION SUMMARY

Subcontracted Laboratories

TestAmerica Los Angeles

3585 Cadillac Ave, Suite A - Costa Mesa, CA 92626

Method Performed: EPA TO15

Samples: PTH0864-01, PTH0864-02

TestAmerica Portland



Darrell Auvil, Project Manager

The results in this report apply to the samples analyzed in accordance with the chain of custody document. This analytical report shall not be reproduced except in full, without the written approval of the laboratory.

Canister Samples Chain of Custody Record

TestAmerica Laboratories, Inc. assumes no liability with respect to the collection and shipment of these samples.

PTA0864

Client Contact Information		Project Manager: <i>Stephanie Bosze</i>					L of 1 COCs																																														
Company: <i>ASH CREEK</i>		Phone: <i>924 4704 ext. 125</i>			Samples Collected By: <i>PU</i>																																																
Address: <i>3015 SW 1st</i>		Email: <i>sbosze@ashcreekassociates.com</i>																																																			
City/State/Zip: <i>PORTLAND OR 97201</i>		Site Contact:																																																			
Phone: <i>503-924-4704</i>		LAB Contact:																																																			
FAX:																																																					
Project Name: <i>MuStar Vane SVE</i>		Analysis Turnaround Time																																																			
Site: <i>1126</i>		Standard (Specify) <input checked="" type="checkbox"/>																																																			
PO #		Rush (Specify)																																																			
Sample Identification	Sample Date(s)	Time Start	Time Stop	Canister Vacuum in Field, "Hg (Start)	Canister Vacuum in Field, "Hg (Stop)	Flow Controller ID	Canister ID	TO-15	TO-14A	TO-3	EPA 3C	EPA 25C	ASTM D-1946	Other (Please specify in notes section)	Sample Type	Indoor Air	Ambient Air	Soil Gas	Landfill Gas	Other (Please specify in notes section)																																	
<i>POST CARBON 082510</i>	<i>8/25/10</i>	<i>1233</i>	<i>1235</i>	<i>>30</i>	<i>6.0</i>	<i>—</i>	<i>9302BB</i>	<i>X</i>																																													
<i>PRE CARBON 082510</i>	<i>↓</i>	<i>1240</i>	<i>1242</i>	<i>>30</i>	<i>5.5</i>	<i>—</i>	<i>9233B</i>	<i>X</i>																																													
<table border="1" style="width:100%; border-collapse: collapse;"> <tr> <th colspan="4">Temperature (Fahrenheit)</th> </tr> <tr> <td></td> <td>Interior</td> <td>Ambient</td> <td></td> </tr> <tr> <td>Start</td> <td></td> <td></td> <td></td> </tr> <tr> <td>Stop</td> <td></td> <td></td> <td></td> </tr> <tr> <th colspan="4">Pressure (inches of Hg)</th> </tr> <tr> <td></td> <td>Interior</td> <td>Ambient</td> <td></td> </tr> <tr> <td>Start</td> <td></td> <td></td> <td></td> </tr> <tr> <td>Stop</td> <td></td> <td></td> <td></td> </tr> </table>																						Temperature (Fahrenheit)					Interior	Ambient		Start				Stop				Pressure (inches of Hg)					Interior	Ambient		Start				Stop			
Temperature (Fahrenheit)																																																					
	Interior	Ambient																																																			
Start																																																					
Stop																																																					
Pressure (inches of Hg)																																																					
	Interior	Ambient																																																			
Start																																																					
Stop																																																					
Special Instructions/QC Requirements & Comments:																																																					
Samples Shipped by: <i>Douglas Urquhart</i>		Date/Time: <i>8/25/10 1640</i>		Samples Received by: <i>Chris Clough/ACA</i>																																																	
Samples Relinquished by: <i>Chris Clough/ACA</i>		Date/Time: <i>8/26/10 @ 12:45</i>		Received by: <i>[Signature]</i>																																																	
Relinquished by: <i>[Signature]</i>		Date/Time: <i>8/26/10 @ 16:35</i>		Received by: <i>[Signature]</i>		<i>1035</i>																																															

Lab Use Only

Shipper Name:

Opened by:

Condition:

TestAmerica Portland
Sample Receiving Checklist

Work Order #: PT H0864 Date/Time Received: 8/26/10 1635
 Client Name and Project: Ashcreek
NuStar Vancouver

Time Zone:
 EDT/EST CDT/CST MDT/MST PDT/PST AK OTHER

Unpacking Checks:

Cooler #(s): /
 Temperatures: /
 Digi #1 Digi #2 IR Gun (Plastic Glass)

Temperature out of Range:

Not enough or No Ice
 Ice Melted
 W/in 4 Hrs of collection
 Other: /

Initials: dm

- | N/A | Yes | No | |
|-------------------------------------|-------------------------------------|--------------------------|---|
| <input checked="" type="checkbox"/> | <input type="checkbox"/> | <input type="checkbox"/> | 1. If ESI client, were temp blanks received? If no, document on NOD. |
| <input checked="" type="checkbox"/> | <input type="checkbox"/> | <input type="checkbox"/> | 2. Cooler Seals intact? (N/A if hand delivered) if no, document on NOD. |
| <input checked="" type="checkbox"/> | <input checked="" type="checkbox"/> | <input type="checkbox"/> | 3. Chain of Custody present? If no, document on NOD. |
| <input checked="" type="checkbox"/> | <input checked="" type="checkbox"/> | <input type="checkbox"/> | 4. Bottles received intact? If no, document on NOD. |
| <input checked="" type="checkbox"/> | <input checked="" type="checkbox"/> | <input type="checkbox"/> | 5. Sample is not multiphasic? If no, document on NOD. |
| <input checked="" type="checkbox"/> | <input checked="" type="checkbox"/> | <input type="checkbox"/> | 6. Proper Container and preservatives used? If no, document on NOD. |
| <input checked="" type="checkbox"/> | <input type="checkbox"/> | <input type="checkbox"/> | 7. pH of all samples checked and meet requirements? If no, document on NOD. |
| <input checked="" type="checkbox"/> | <input type="checkbox"/> | <input type="checkbox"/> | 8. Cyanide samples checked for sulfides and meet requirements? If no, notify PM. |
| <input checked="" type="checkbox"/> | <input type="checkbox"/> | <input type="checkbox"/> | 9. HF Dilution required? |
| <input checked="" type="checkbox"/> | <input checked="" type="checkbox"/> | <input type="checkbox"/> | 10. Sufficient volume provided for all analysis? If no, document on NOD and consult PM before proceeding. |
| <input checked="" type="checkbox"/> | <input checked="" type="checkbox"/> | <input type="checkbox"/> | 11. Did chain of custody agree with samples received? If no, document on NOD. |
| <input checked="" type="checkbox"/> | <input checked="" type="checkbox"/> | <input type="checkbox"/> | 12. Is the "Sampled by" section of the COC completed? |
| <input checked="" type="checkbox"/> | <input type="checkbox"/> | <input type="checkbox"/> | 13. Were VOA/Oil Syringe samples without headspace? |
| <input checked="" type="checkbox"/> | <input type="checkbox"/> | <input type="checkbox"/> | 14. Were VOA vials preserved? <input type="checkbox"/> HCl <input type="checkbox"/> Sodium Thiosulfate <input type="checkbox"/> Ascorbic Acid |
| <input checked="" type="checkbox"/> | <input checked="" type="checkbox"/> | <input type="checkbox"/> | 15. Did samples require preservation with sodium thiosulfate? |
| <input checked="" type="checkbox"/> | <input type="checkbox"/> | <input type="checkbox"/> | 16. If yes to #15, was the residual chlorine test negative? If no, document on NOD. |
| <input checked="" type="checkbox"/> | <input type="checkbox"/> | <input type="checkbox"/> | 17. Are dissolved/field filtered metals bottles sediment-free? If no, document on NOD. |
| <input checked="" type="checkbox"/> | <input type="checkbox"/> | <input type="checkbox"/> | 18. Is sufficient volume provided for client requested MS/MSD or matrix duplicates? If no, document on NOD and contact PM before proceeding. |
| <input checked="" type="checkbox"/> | <input type="checkbox"/> | <input type="checkbox"/> | 19. Are analyses with short holding times received in hold? |
| <input checked="" type="checkbox"/> | <input checked="" type="checkbox"/> | <input type="checkbox"/> | 20. Was Standard Turn Around (TAT) requested? |
| <input checked="" type="checkbox"/> | <input checked="" type="checkbox"/> | <input type="checkbox"/> | 21. Receipt date(s) < 48 hours past the collection date(s)? If no, notify PM. |

TestAmerica Portland
Sample Receiving Checklist

Work Order #: PTH0864

Initials: MM

Login Checks:

- | N/A | Yes | No | |
|-------------------------------------|-------------------------------------|--------------------------|---|
| <input checked="" type="checkbox"/> | <input checked="" type="checkbox"/> | <input type="checkbox"/> | 22. Sufficient volume provided for all analysis? If no, document on NOD & contact PM. |
| <input checked="" type="checkbox"/> | <input type="checkbox"/> | <input type="checkbox"/> | 23. Sufficient volume provided for client requested MS/MSD or matrix duplicates? If no, document on NOD and contact PM. |
| | <input checked="" type="checkbox"/> | <input type="checkbox"/> | 24. Did the chain of custody include "received by" and "relinquished by" signatures, dates and times? |
| <input checked="" type="checkbox"/> | <input type="checkbox"/> | <input type="checkbox"/> | 25. Were special log in instructions read and followed? |
| | <input checked="" type="checkbox"/> | <input type="checkbox"/> | 26. Were tests logged checked against the COC? |
| <input checked="" type="checkbox"/> | <input type="checkbox"/> | <input type="checkbox"/> | 27. Were rush notices printed and delivered? |
| <input checked="" type="checkbox"/> | <input type="checkbox"/> | <input type="checkbox"/> | 28. Were short hold notices printed and delivered? |
| <input type="checkbox"/> | <input checked="" type="checkbox"/> | <input type="checkbox"/> | 29. Were subcontract COCs printed? |
| <input checked="" type="checkbox"/> | <input type="checkbox"/> | <input type="checkbox"/> | 30. Was HF dilution logged? |

Initials: MM

Labeling and Storage Checks:

- | N/A | Yes | No | |
|-------------------------------------|-------------------------------------|--------------------------|---|
| <input checked="" type="checkbox"/> | <input checked="" type="checkbox"/> | <input type="checkbox"/> | 31. Were the subcontracted samples/containers put in Sx fridge? |
| <input checked="" type="checkbox"/> | <input type="checkbox"/> | <input type="checkbox"/> | 32. Were sample bottles and COC double checked for dissolved/filtered metals? |
| | <input checked="" type="checkbox"/> | <input type="checkbox"/> | 33. Did the sample ID, Date, and Time from label match what was logged? |
| <input checked="" type="checkbox"/> | <input type="checkbox"/> | <input type="checkbox"/> | 34. Were Foreign sample stickers affixed to each container and containers stored in foreign fridge? |
| <input checked="" type="checkbox"/> | <input type="checkbox"/> | <input type="checkbox"/> | 35. Were HF stickers affixed to each container, and containers stored in Sx fridge? |
| <input checked="" type="checkbox"/> | <input type="checkbox"/> | <input type="checkbox"/> | 36. Was an NOD for created for noted discrepancies and placed in folder? |

Document any problems or discrepancies and the actions taken to resolve them on a Notice of Discrepancy form (NOD).

*on shelf
 NO
 Refrigeration
 needed*



Laboratory Results

Stephanie Bosze
Ash Creek Assoc.
3015 SW First Avenue
Portland, OR 97201-4707

Subject : 2 Water Samples
Project Name : 3Q10 NUSTAR VANCOUVER GWM
Project Number : E3WR-0028
P.O. Number : 4501259182-20

Dear Ms. Bosze,

Chemical analysis of the samples referenced above has been completed. Summaries of the data are contained on the following pages. Sample(s) were received under documented chain-of-custody. US EPA protocols for sample storage and preservation were followed. Testing procedures comply with the 2003 NELAC standard. All soil samples are reported on a total weight (wet weight) basis unless noted otherwise in the case narrative. Laboratory results relate only to the samples tested. This report may be freely reproduced in full, but may only be reproduced in part with the express permission of Kiff Analytical, LLC. Kiff Analytical, LLC is certified by the State of California under the National Environmental Laboratory Accreditation Program (NELAP), lab # 08263CA. If you have any questions regarding procedures or results, please call me at 530-297-4800.

Sincerely,



Joel Kiff

Subject : 2 Water Samples
Project Name : 3Q10 NUSTAR VANCOUVER GWM
Project Number : E3WR-0028
P.O. Number : 4501259182-20

Case Narrative

Matrix Spike/Matrix Spike Duplicate results associated with samples MGMS2-40 and MW-9 for the analyte Chloride were affected by the analyte concentration present in the un-spiked sample.

A version of this report was previously issued on 09/24/10. This revised version replaces that report.



Report Number : 74643

Date : 10/06/2010

Project Name : **3Q10 NUSTAR VANCOUVER GWM**

Project Number : **E3WR-0028**

Sample : **MGMS2-40**

Matrix : Water

Lab Number : 74643-01

Sample Date :09/21/2010

Parameter	Measured Value	Method Reporting Limit	Units	Analysis Method	Date/Time Analyzed
Chloride	20	5.0	mg/L	EPA 300.0	09/22/10 19:13
Nitrate as N	560	20	mg/L	EPA 300.0	09/23/10 08:20
Nitrite as N	< 0.10	0.10	mg/L	EPA 300.0	09/23/10 11:10
Sulfate	110	5.0	mg/L	EPA 300.0	09/22/10 19:13

Sample : **MW-9**

Matrix : Water

Lab Number : 74643-02

Sample Date :09/21/2010

Parameter	Measured Value	Method Reporting Limit	Units	Analysis Method	Date/Time Analyzed
Chloride	5.9	0.50	mg/L	EPA 300.0	09/23/10 10:00
Nitrate as N	89	10	mg/L	EPA 300.0	09/23/10 08:53
Nitrite as N	< 0.10	0.10	mg/L	EPA 300.0	09/22/10 19:47
Sulfate	49	1.0	mg/L	EPA 300.0	09/24/10 12:30

Report Number : 74643

Date : 10/06/2010

QC Report : Method Blank Data

Project Name : **3Q10 NUSTAR VANCOUVER GWM**

Project Number : **E3WR-0028**

<u>Parameter</u>	<u>Measured Value</u>	<u>Method Reporting Limit</u>	<u>Units</u>	<u>Analysis Method</u>	<u>Date Analyzed</u>
Chloride	< 0.50	0.50	mg/L	EPA 300.0	09/23/2010
Nitrite as N	< 0.10	0.10	mg/L	EPA 300.0	09/23/2010
Sulfate	< 0.50	0.50	mg/L	EPA 300.0	09/23/2010
Sulfate	< 0.50	0.50	mg/L	EPA 300.0	09/24/2010

<u>Parameter</u>	<u>Measured Value</u>	<u>Method Reporting Limit</u>	<u>Units</u>	<u>Analysis Method</u>	<u>Date Analyzed</u>
------------------	-----------------------	-------------------------------	--------------	------------------------	----------------------

QC Report : Matrix Spike/ Matrix Spike Duplicate

Project Name : **3Q10 NUSTAR VANCOUVER GWM**

Project Number : **E3WR-0028**

Parameter	Spiked Sample	Sample Value	Spike Level	Spike Dup. Level	Spiked Sample Value	Duplicate Spiked Sample Value	Units	Analysis Method	Date Analyzed	Spiked Sample Percent Recov.	Duplicate Spiked Sample Percent Recov.	Relative Percent Diff.	Spiked Sample Percent Recov. Limit	Relative Percent Diff. Limit
Chloride														
Nitrite as N	74567-01	46	2.50	2.50	48.7	48.1	mg/L	EPA 300.0	9/22/10	90.7	65.6	1.30	85.0-115	10
Nitrate as N	74567-01	< 0.10	0.500	0.500	0.463	0.442	mg/L	EPA 300.0	9/22/10	92.6	88.3	4.76	85.0-115	10
Sulfate	74567-01	< 0.10	0.500	0.500	0.465	0.465	mg/L	EPA 300.0	9/22/10	93.0	93.0	0.0925	85.0-115	10
Sulfate	74567-01	28	2.50	2.50	30.4	29.9	mg/L	EPA 300.0	9/22/10	104	85.7	1.49	85.0-115	10
Sulfate	74663-04	20	2.50	2.50	22.2	22.3	mg/L	EPA 300.0	9/24/10	96.5	100	0.447	85.0-115	10

QC Report : Laboratory Control Sample (LCS)Project Name : **3Q10 NUSTAR VANCOUVER GWM**Project Number : **E3WR-0028**

Parameter	Spike Level	Units	Analysis Method	Date Analyzed	LCS Percent Recov.	LCS Percent Recov. Limit
Chloride	2.50	mg/L	EPA 300.0	9/22/10	97.6	85.0-115
Nitrite as N	0.500	mg/L	EPA 300.0	9/22/10	94.6	85.0-115
Nitrate as N	0.500	mg/L	EPA 300.0	9/22/10	92.6	85.0-115
Sulfate	2.50	mg/L	EPA 300.0	9/22/10	113	85.0-115
Sulfate	2.50	mg/L	EPA 300.0	9/24/10	93.4	85.0-115



2795 2nd Street, Suite 300
 Davis, CA 95618
 Lab: 530.297.4800
 Fax: 530.297.4802

SRG # / Lab No.

74643

Page 1 of 1

Project Contact (Hardcopy or PDF To):
SBOSZE@ASHCREEKASSOCIATES.COM

Company / Address:
ASH CREEK / 3015 SW FIRST AVE, PORTLAND

Phone Number:
(503) 924-4704

Fax Number:

Project #:

P.O. #:
4501259182

Project Name:
3Q10 NUSTAR VANCOUVER GWM

California EDF Report? Yes No

Sampling Company Log Code:

Global ID:

EDF Deliverable To (Email Address):
SBOSZE@ASHCREEKASSOCIATES.COM

Bill to: **RENEE ROBINSON, SAME NUSTAR ENERGY, L.P.**

Sampler Print Name:
MICHAEL WHITSON

Sample Signature:

Chain-of-Custody Record and Analysis Request

Project Address:	Sampling		Container				Preservative			Matrix			
	Date	Time	40 ml VOA	Sleeve	Poly	Glass	Tedlar	HCl	HNO ₃	None	Water	Soil	Air
Sample Designation													
MGMS2-40	09-21	1400			1				X		X		
MW-7	09-21	1610			1				X		X		

Analysis Request										TAT	
PLEASE CIRCLE METHOD											
<input type="checkbox"/>	<input type="checkbox"/>	<input type="checkbox"/>	<input type="checkbox"/>	<input type="checkbox"/>	<input type="checkbox"/>	<input type="checkbox"/>	<input type="checkbox"/>	<input type="checkbox"/>	<input type="checkbox"/>	<input type="checkbox"/>	12 hr
<input type="checkbox"/>	<input type="checkbox"/>	<input type="checkbox"/>	<input type="checkbox"/>	<input type="checkbox"/>	<input type="checkbox"/>	<input type="checkbox"/>	<input type="checkbox"/>	<input type="checkbox"/>	<input type="checkbox"/>	<input type="checkbox"/>	24 hr
<input checked="" type="checkbox"/>	<input type="checkbox"/>	<input type="checkbox"/>	<input type="checkbox"/>	<input type="checkbox"/>	<input type="checkbox"/>	<input type="checkbox"/>	<input type="checkbox"/>	<input type="checkbox"/>	<input type="checkbox"/>	<input type="checkbox"/>	48 hr
<input type="checkbox"/>	<input type="checkbox"/>	<input type="checkbox"/>	<input type="checkbox"/>	<input type="checkbox"/>	<input type="checkbox"/>	<input type="checkbox"/>	<input type="checkbox"/>	<input type="checkbox"/>	<input type="checkbox"/>	<input type="checkbox"/>	72hr
<input type="checkbox"/>	<input type="checkbox"/>	<input type="checkbox"/>	<input type="checkbox"/>	<input type="checkbox"/>	<input type="checkbox"/>	<input type="checkbox"/>	<input type="checkbox"/>	<input type="checkbox"/>	<input type="checkbox"/>	<input type="checkbox"/>	1 wk

For Lab Use Only

Relinquished by: **MICHAEL WHITSON**
 Date: **09-21** Time: **1630**

Relinquished by: _____
 Date: _____ Time: _____

Relinquished by: _____
 Date: **092210** Time: **1040**

Remarks: **SHORT HOLD TIME FOR ANIONS**

For Lab Use Only: Sample Receipt					
Temp °C	Initials	Date	Time	Therm. ID #	Coolant Present
2.4	KT	092210	1040	ILS	<input checked="" type="checkbox"/> Yes / <input type="checkbox"/> No

Page 7 of 8



Report Number : 75032

Date : 10/26/2010

Laboratory Results

Stephanie Bosze
Ash Creek Assoc.
3015 SW First Avenue
Portland, OR 97201-4707

Subject : 3 Water Samples
Project Name : IA Confirmation Sampling
Project Number : E3WR-0028
P.O. Number : 4501259182-20

Dear Ms. Bosze,

Chemical analysis of the samples referenced above has been completed. Summaries of the data are contained on the following pages. Sample(s) were received under documented chain-of-custody. US EPA protocols for sample storage and preservation were followed. Testing procedures comply with the 2003 NELAC standard. All soil samples are reported on a total weight (wet weight) basis unless noted otherwise in the case narrative. Laboratory results relate only to the samples tested. This report may be freely reproduced in full, but may only be reproduced in part with the express permission of Kiff Analytical, LLC. Kiff Analytical, LLC is certified by the State of California under the National Environmental Laboratory Accreditation Program (NELAP), lab # 08263CA. If you have any questions regarding procedures or results, please call me at 530-297-4800.

Sincerely,



Joel Kiff

Subject : 3 Water Samples
Project Name : IA Confirmation Sampling
Project Number : E3WR-0028
P.O. Number : 4501259182-20

Case Narrative

Matrix Spike/Matrix Spike Duplicate results associated with samples MGMSI-40, MW-12 and MW-19 for the analyte Nitrate as N were affected by the analyte concentration present in the un-spiked sample. Recoveries were calculated using data points beyond the calibration range.



Report Number : 75032

Date : 10/26/2010

Project Name : **IA Confirmation Sampling**

Project Number : **E3WR-0028**

Sample : **MW-12**

Matrix : Water

Lab Number : 75032-01

Sample Date :10/19/2010

Parameter	Measured Value	Method Reporting Limit	Units	Analysis Method	Date/Time Analyzed
Nitrate as N	59	5.0	mg/L	EPA 300.0	10/20/10 23:45

Sample : **MW-19**

Matrix : Water

Lab Number : 75032-02

Sample Date :10/19/2010

Parameter	Measured Value	Method Reporting Limit	Units	Analysis Method	Date/Time Analyzed
Nitrate as N	300	10	mg/L	EPA 300.0	10/21/10 00:13

Sample : **MGMSI-40**

Matrix : Water

Lab Number : 75032-03

Sample Date :10/19/2010

Parameter	Measured Value	Method Reporting Limit	Units	Analysis Method	Date/Time Analyzed
Nitrate as N	390	50	mg/L	EPA 300.0	10/21/10 00:41

Report Number : 75032

Date : 10/26/2010

QC Report : Method Blank Data

Project Name : **IA Confirmation Sampling**

Project Number : **E3WR-0028**

<u>Parameter</u>	<u>Measured Value</u>	<u>Method Reporting Limit</u>	<u>Units</u>	<u>Analysis Method</u>	<u>Date Analyzed</u>
Nitrate as N	< 0.10	0.10	mg/L	EPA 300.0	10/20/2010

<u>Parameter</u>	<u>Measured Value</u>	<u>Method Reporting Limit</u>	<u>Units</u>	<u>Analysis Method</u>	<u>Date Analyzed</u>
------------------	-----------------------	-------------------------------	--------------	------------------------	----------------------

QC Report : Matrix Spike/ Matrix Spike Duplicate

Project Name : **IA Confirmation Sampling**

Project Number : **E3WR-0028**

Parameter	Spiked Sample	Sample Value	Spike Level	Spike Dup. Level	Spiked Sample Value	Duplicate Spiked Sample Value	Units	Analysis Method	Date Analyzed	Spiked Sample Percent Recov.	Duplicate Spiked Sample Percent Recov.	Relative Percent Diff.	Spiked Sample Percent Recov. Limit	Relative Percent Diff. Limit
Nitrate as N	75032-01	43	0.500	0.500	45.8	45.6	mg/L	EPA 300.0	10/20/10	622	595	0.291	85.0-115	10

QC Report : Laboratory Control Sample (LCS)

Project Name : **IA Confirmation Sampling**

Project Number : **E3WR-0028**

Parameter	Spike Level	Units	Analysis Method	Date Analyzed	LCS Percent Recov.	LCS Percent Recov. Limit
Nitrate as N	0.500	mg/L	EPA 300.0	10/20/10	93.6	85.0-115



2795 2nd Street, Suite 300
 Davis, CA 95618
 Lab: 530.297.4800
 Fax: 530.297.4802

SRG # / Lab No. 75032

Page 1 of 1

Project Contact (Hardcopy or PDF To): Stephanie Boss
 Company / Address: Ash Creek
 Phone Number: 503-924-4704 X125
 Fax Number: 503-943-6257
 Project #: 1126-09 P.O. #: 1126-09
 Project Name: TA Confirmation Sampling
 California EDF Report? Yes No
 Sampling Company Log Code:
 Global ID:
 EDF Deliverable To (Email Address):
 Bill to: NuStar
 Sampler Signature: Stephanie Boss

Chain-of-Custody Record and Analysis Request

Sample Designation	Sampling		Container				Preservative			Matrix			
	Date	Time	40 ml VOA	Sleeve	Poly	Glass	Tedlar	HCl	HNO ₃	None	Water	Soil	Air
MW-12	10.19.10	1542			X					X	X		
MW-79	10.19.10	1655			X					X	X		
M6MS1-40	10.19.10	16:55 17:00			X					X	X		

Analysis Request												TAT
circle method												For Lab Use Only
<input type="checkbox"/>	<input type="checkbox"/>	<input type="checkbox"/>	<input type="checkbox"/>	<input type="checkbox"/>	<input type="checkbox"/>	<input type="checkbox"/>	<input type="checkbox"/>	<input type="checkbox"/>	<input type="checkbox"/>	<input type="checkbox"/>	<input type="checkbox"/>	
<input type="checkbox"/>	<input type="checkbox"/>	<input type="checkbox"/>	<input type="checkbox"/>	<input type="checkbox"/>	<input type="checkbox"/>	<input type="checkbox"/>	<input type="checkbox"/>	<input type="checkbox"/>	<input type="checkbox"/>	<input type="checkbox"/>	<input type="checkbox"/>	<input type="checkbox"/> 24 hr
<input type="checkbox"/>	<input type="checkbox"/>	<input type="checkbox"/>	<input type="checkbox"/>	<input type="checkbox"/>	<input type="checkbox"/>	<input type="checkbox"/>	<input type="checkbox"/>	<input type="checkbox"/>	<input type="checkbox"/>	<input type="checkbox"/>	<input type="checkbox"/>	<input type="checkbox"/> 48hr
<input type="checkbox"/>	<input type="checkbox"/>	<input type="checkbox"/>	<input type="checkbox"/>	<input type="checkbox"/>	<input type="checkbox"/>	<input type="checkbox"/>	<input type="checkbox"/>	<input type="checkbox"/>	<input type="checkbox"/>	<input type="checkbox"/>	<input type="checkbox"/>	<input type="checkbox"/> 72hr
<input checked="" type="checkbox"/>	<input type="checkbox"/>	<input type="checkbox"/>	<input type="checkbox"/>	<input type="checkbox"/>	<input type="checkbox"/>	<input type="checkbox"/>	<input type="checkbox"/>	<input type="checkbox"/>	<input type="checkbox"/>	<input type="checkbox"/>	<input type="checkbox"/>	<input checked="" type="checkbox"/> wk

W.E.T. Lead (STLC) Nitrate EPA 300

Relinquished by: Stephanie Boss Date: 10.19.10 Time: 18:30
 Relinquished by: _____ Date: _____ Time: _____
 Relinquished by: _____ Date: 10/20/10 Time: 1014 Received by Laboratory: E. Steif Analytical

Remarks: 48 hr. hold time.

For Lab Use Only: Sample Receipt					
Temp °C	Initials	Date	Time	Therm. ID #	Coolant Present
					Yes / No

SAMPLE RECEIPT CHECKLIST

RECEIVER
ECS
Initials

SRG#: 75032 Date: 102010
Project ID: IA Confirmation Sampling
Method of Receipt: Courier Over-the-counter Shipper

COC Inspection

Is COC present? Yes No
 Custody seals on shipping container? Intact Broken Not present N/A
 Is COC Signed by Relinquisher? Yes No Dated? Yes No
 Is sampler name legibly indicated on COC? Yes No
 Is analysis or hold requested for all samples? Yes No
 Is the turnaround time indicated on COC? Yes No
 Is COC free of whiteout and uninitialed cross-outs? Yes No, Whiteout No, Cross-outs

Sample Inspection

Coolant Present: Yes No (includes water)
 Temperature °C 0.2 Therm. ID# 125 Initial ECS Date/Time 102010 1012 N/A
 Are there custody seals on sample containers? Intact Broken Not present
 Do containers match COC? Yes No No, COC lists absent sample(s) No, Extra sample(s) present
 Are there samples matrices other than soil, water, air or carbon? Yes No
 Are any sample containers broken, leaking or damaged? Yes No
 Are preservatives indicated? Yes, on sample containers Yes, on COC Not indicated N/A
 Are preservatives correct for analyses requested? Yes No N/A
 Are samples within holding time for analyses requested? Yes No
 Are the correct sample containers used for the analyses requested? Yes No
 Is there sufficient sample to perform testing? Yes No
 Does any sample contain product, have strong odor or are otherwise suspected to be hot? Yes No

Receipt Details
 Matrix WA Container type Poly # of containers received 3
 Matrix _____ Container type _____ # of containers received _____
 Matrix _____ Container type _____ # of containers received _____
 Date and Time Sample Put into Temp Storage Date: 102010 Time: 1014

Quicklog

Are the Sample ID's indicated: On COC On sample container(s) On Both Not indicated
 If Sample ID's are listed on both COC and containers, do they all match? Yes No N/A
 Is the Project ID indicated: On COC On sample container(s) On Both Not indicated
 If project ID is listed on both COC and containers, do they all match? Yes No N/A
 Are the sample collection dates indicated: On COC On sample container(s) On Both Not indicated
 If collection dates are listed on both COC and containers, do they all match? Yes No N/A
 Are the sample collection times indicated: On COC On sample container(s) On Both Not indicated
 If collection times are listed on both COC and containers, do they all match? Yes No N/A

COMMENTS: Project Name - not sure IF "IA" or "JA"
ECS 102010 1014



Laboratory Results

Stephanie Bosze
Ash Creek Assoc.
3015 SW First Avenue
Portland, OR 97201-4707

Subject : 11 Water Samples
Project Name : NuStar Vancouver
Project Number : E3WR-0028
P.O. Number : 4501259182-20

Dear Ms. Bosze,

Chemical analysis of the samples referenced above has been completed. Summaries of the data are contained on the following pages. Sample(s) were received under documented chain-of-custody. US EPA protocols for sample storage and preservation were followed. Testing procedures comply with the 2003 NELAC standard. All soil samples are reported on a total weight (wet weight) basis unless noted otherwise in the case narrative. Laboratory results relate only to the samples tested. This report may be freely reproduced in full, but may only be reproduced in part with the express permission of Kiff Analytical, LLC. Kiff Analytical, LLC is certified by the State of California under the National Environmental Laboratory Accreditation Program (NELAP), lab # 08263CA. If you have any questions regarding procedures or results, please call me at 530-297-4800.

Sincerely,



Joel Kiff

Subject : 11 Water Samples
Project Name : NuStar Vancouver
Project Number : E3WR-0028
P.O. Number : 4501259182-20

Case Narrative

A version of this report was previously issued on 09/30/2010. This revised version replaces that report.

California Laboratory Services and Exova (West Coast/Bodycoat) provided analytical testing associated with these samples, but these labs are not accredited by the National Environmental Laboratory Accreditation Program (NELAP).

Matrix Spike/Matrix Spike Duplicate results associated with sample CB-3 (35) for the analyte Chloride were affected by the analyte concentration present in the un-spiked sample.

Napthalene results on QC Report: Matrix/Matrix Spike Duplicate page 33 are the result of carry-over from the preceding sample analysis and are not reflected in the sample data.

Repeat analysis by EPA Method 8260B yielded inconsistent results for sample CB-2 (45). Data reported is associated with the client specified Matrix Spike/Matrix Spike Duplicate.

Sample : **CB-1 (35)**

Project Name : **NuStar Vancouver**

Project Number : **E3WR-0028**

Lab Number : 74644-01

Matrix : Water

Sample Date :09/20/2010

Analysis Method: EPA 8260B

Parameter	Measured Value	Method Reporting Limit	Units	Date/Time Analyzed
Dichlorodifluoromethane	< 2.5	2.5	ug/L	09/29/10 03:25
Chloromethane	< 2.5	2.5	ug/L	09/29/10 03:25
Vinyl Chloride	< 2.5	2.5	ug/L	09/29/10 03:25
Bromomethane	< 50	50	ug/L	09/29/10 03:25
Chloroethane	< 2.5	2.5	ug/L	09/29/10 03:25
Trichlorofluoromethane	< 2.5	2.5	ug/L	09/29/10 03:25
1,1-Dichloroethene	< 2.5	2.5	ug/L	09/29/10 03:25
Methylene Chloride	< 5.0	5.0	ug/L	09/29/10 03:25
trans-1,2-Dichloroethene	< 2.5	2.5	ug/L	09/29/10 03:25
1,1-Dichloroethane	3.2	2.5	ug/L	09/29/10 03:25
2,2-Dichloropropane	< 2.5	2.5	ug/L	09/29/10 03:25
cis-1,2-Dichloroethene	46	2.5	ug/L	09/29/10 03:25
Chloroform	< 2.5	2.5	ug/L	09/29/10 03:25
Bromochloromethane	< 2.5	2.5	ug/L	09/29/10 03:25
1,1,1-Trichloroethane	6.0	2.5	ug/L	09/29/10 03:25
1,1-Dichloropropene	< 2.5	2.5	ug/L	09/29/10 03:25
1,2-Dichloroethane	< 2.5	2.5	ug/L	09/29/10 03:25
Carbon Tetrachloride	< 2.5	2.5	ug/L	09/29/10 03:25
Benzene	< 2.5	2.5	ug/L	09/29/10 03:25
Trichloroethene	170	2.5	ug/L	09/29/10 03:25
1,2-Dichloropropane	< 2.5	2.5	ug/L	09/29/10 03:25
Bromodichloromethane	< 2.5	2.5	ug/L	09/29/10 03:25
Dibromomethane	< 2.5	2.5	ug/L	09/29/10 03:25
cis-1,3-Dichloropropene	< 2.5	2.5	ug/L	09/29/10 03:25
Toluene	< 2.5	2.5	ug/L	09/29/10 03:25
trans-1,3-Dichloropropene	< 2.5	2.5	ug/L	09/29/10 03:25
1,1,2-Trichloroethane	< 2.5	2.5	ug/L	09/29/10 03:25
1,3-Dichloropropane	< 2.5	2.5	ug/L	09/29/10 03:25
Tetrachloroethene	650	2.5	ug/L	09/29/10 03:25
Dibromochloromethane	< 2.5	2.5	ug/L	09/29/10 03:25
1,2-Dibromoethane	< 2.5	2.5	ug/L	09/29/10 03:25
Chlorobenzene	< 2.5	2.5	ug/L	09/29/10 03:25
1,1,1,2-Tetrachloroethane	< 2.5	2.5	ug/L	09/29/10 03:25
Ethylbenzene	< 2.5	2.5	ug/L	09/29/10 03:25

Sample : **CB-1 (35)**

Project Name : **NuStar Vancouver**

Project Number : **E3WR-0028**

Lab Number : 74644-01

Matrix : Water

Sample Date :09/20/2010

Analysis Method: EPA 8260B

Parameter	Measured Value	Method Reporting Limit	Units	Date/Time Analyzed
P,M-Xylene	< 2.5	2.5	ug/L	09/29/10 03:25
O-Xylene	< 2.5	2.5	ug/L	09/29/10 03:25
Styrene	< 2.5	2.5	ug/L	09/29/10 03:25
Isopropyl benzene	< 2.5	2.5	ug/L	09/29/10 03:25
Bromoform	< 2.5	2.5	ug/L	09/29/10 03:25
1,1,2,2-Tetrachloroethane	< 2.5	2.5	ug/L	09/29/10 03:25
1,2,3-Trichloropropane	< 2.5	2.5	ug/L	09/29/10 03:25
n-Propylbenzene	< 2.5	2.5	ug/L	09/29/10 03:25
Bromobenzene	< 2.5	2.5	ug/L	09/29/10 03:25
1,3,5-Trimethylbenzene	< 2.5	2.5	ug/L	09/29/10 03:25
2+4-Chlorotoluene	< 5.0	5.0	ug/L	09/29/10 03:25
tert-Butylbenzene	< 2.5	2.5	ug/L	09/29/10 03:25
1,2,4-Trimethylbenzene	< 2.5	2.5	ug/L	09/29/10 03:25
sec-Butylbenzene	< 2.5	2.5	ug/L	09/29/10 03:25
p-Isopropyltoluene	< 2.5	2.5	ug/L	09/29/10 03:25
1,3-Dichlorobenzene	< 2.5	2.5	ug/L	09/29/10 03:25
1,4-Dichlorobenzene	< 2.5	2.5	ug/L	09/29/10 03:25
n-Butylbenzene	< 2.5	2.5	ug/L	09/29/10 03:25
1,2-Dichlorobenzene	< 2.5	2.5	ug/L	09/29/10 03:25
1,2-Dibromo-3-chloropropane	< 2.5	2.5	ug/L	09/29/10 03:25
1,2,4-Trichlorobenzene	< 2.5	2.5	ug/L	09/29/10 03:25
Hexachlorobutadiene	< 2.5	2.5	ug/L	09/29/10 03:25
Naphthalene	< 2.5	2.5	ug/L	09/29/10 03:25
1,2,3-Trichlorobenzene	< 2.5	2.5	ug/L	09/29/10 03:25
1,2-Dichloroethane-d4 (Surr)	103		% Recovery	09/29/10 03:25
4-Bromofluorobenzene (Surr)	99.7		% Recovery	09/29/10 03:25
Toluene - d8 (Surr)	99.5		% Recovery	09/29/10 03:25

Sample : **CB-1 (45)**

Project Name : **NuStar Vancouver**

Project Number : **E3WR-0028**

Lab Number : 74644-02

Matrix : Water

Sample Date :09/20/2010

Analysis Method: EPA 8260B

Parameter	Measured Value	Method Reporting Limit	Units	Date/Time Analyzed
Dichlorodifluoromethane	< 5.0	5.0	ug/L	09/29/10 03:59
Chloromethane	< 5.0	5.0	ug/L	09/29/10 03:59
Vinyl Chloride	40	5.0	ug/L	09/29/10 03:59
Bromomethane	< 100	100	ug/L	09/29/10 03:59
Chloroethane	< 5.0	5.0	ug/L	09/29/10 03:59
Trichlorofluoromethane	< 5.0	5.0	ug/L	09/29/10 03:59
1,1-Dichloroethene	53	5.0	ug/L	09/29/10 03:59
Methylene Chloride	< 5.0	5.0	ug/L	09/29/10 03:59
trans-1,2-Dichloroethene	20	5.0	ug/L	09/29/10 03:59
1,1-Dichloroethane	260	5.0	ug/L	09/29/10 03:59
2,2-Dichloropropane	< 5.0	5.0	ug/L	09/29/10 03:59
cis-1,2-Dichloroethene	1400	5.0	ug/L	09/29/10 03:59
Chloroform	< 5.0	5.0	ug/L	09/29/10 03:59
Bromochloromethane	< 5.0	5.0	ug/L	09/29/10 03:59
1,1,1-Trichloroethane	130	5.0	ug/L	09/29/10 03:59
1,1-Dichloropropene	< 5.0	5.0	ug/L	09/29/10 03:59
1,2-Dichloroethane	< 5.0	5.0	ug/L	09/29/10 03:59
Carbon Tetrachloride	< 5.0	5.0	ug/L	09/29/10 03:59
Benzene	< 5.0	5.0	ug/L	09/29/10 03:59
Trichloroethene	1700	5.0	ug/L	09/29/10 03:59
1,2-Dichloropropane	< 5.0	5.0	ug/L	09/29/10 03:59
Bromodichloromethane	< 5.0	5.0	ug/L	09/29/10 03:59
Dibromomethane	< 5.0	5.0	ug/L	09/29/10 03:59
cis-1,3-Dichloropropene	< 5.0	5.0	ug/L	09/29/10 03:59
Toluene	< 5.0	5.0	ug/L	09/29/10 03:59
trans-1,3-Dichloropropene	< 5.0	5.0	ug/L	09/29/10 03:59
1,1,2-Trichloroethane	< 5.0	5.0	ug/L	09/29/10 03:59
1,3-Dichloropropane	< 5.0	5.0	ug/L	09/29/10 03:59
Tetrachloroethene	1400	5.0	ug/L	09/29/10 03:59
Dibromochloromethane	< 5.0	5.0	ug/L	09/29/10 03:59
1,2-Dibromoethane	< 5.0	5.0	ug/L	09/29/10 03:59
Chlorobenzene	< 5.0	5.0	ug/L	09/29/10 03:59
1,1,1,2-Tetrachloroethane	< 5.0	5.0	ug/L	09/29/10 03:59
Ethylbenzene	< 5.0	5.0	ug/L	09/29/10 03:59

Sample : **CB-1 (45)**

Project Name : **NuStar Vancouver**

Project Number : **E3WR-0028**

Lab Number : 74644-02

Matrix : Water

Sample Date :09/20/2010

Analysis Method: EPA 8260B

Parameter	Measured Value	Method Reporting Limit	Units	Date/Time Analyzed
P,M-Xylene	< 5.0	5.0	ug/L	09/29/10 03:59
O-Xylene	< 5.0	5.0	ug/L	09/29/10 03:59
Styrene	< 5.0	5.0	ug/L	09/29/10 03:59
Isopropyl benzene	< 5.0	5.0	ug/L	09/29/10 03:59
Bromoform	< 5.0	5.0	ug/L	09/29/10 03:59
1,1,2,2-Tetrachloroethane	< 5.0	5.0	ug/L	09/29/10 03:59
1,2,3-Trichloropropane	< 5.0	5.0	ug/L	09/29/10 03:59
n-Propylbenzene	< 5.0	5.0	ug/L	09/29/10 03:59
Bromobenzene	< 5.0	5.0	ug/L	09/29/10 03:59
1,3,5-Trimethylbenzene	< 5.0	5.0	ug/L	09/29/10 03:59
2+4-Chlorotoluene	< 10	10	ug/L	09/29/10 03:59
tert-Butylbenzene	< 5.0	5.0	ug/L	09/29/10 03:59
1,2,4-Trimethylbenzene	< 5.0	5.0	ug/L	09/29/10 03:59
sec-Butylbenzene	< 5.0	5.0	ug/L	09/29/10 03:59
p-Isopropyltoluene	< 5.0	5.0	ug/L	09/29/10 03:59
1,3-Dichlorobenzene	< 5.0	5.0	ug/L	09/29/10 03:59
1,4-Dichlorobenzene	< 5.0	5.0	ug/L	09/29/10 03:59
n-Butylbenzene	< 5.0	5.0	ug/L	09/29/10 03:59
1,2-Dichlorobenzene	< 5.0	5.0	ug/L	09/29/10 03:59
1,2-Dibromo-3-chloropropane	< 5.0	5.0	ug/L	09/29/10 03:59
1,2,4-Trichlorobenzene	< 5.0	5.0	ug/L	09/29/10 03:59
Hexachlorobutadiene	< 5.0	5.0	ug/L	09/29/10 03:59
Naphthalene	< 5.0	5.0	ug/L	09/29/10 03:59
1,2,3-Trichlorobenzene	< 5.0	5.0	ug/L	09/29/10 03:59
1,2-Dichloroethane-d4 (Surr)	100		% Recovery	09/29/10 03:59
4-Bromofluorobenzene (Surr)	98.2		% Recovery	09/29/10 03:59
Toluene - d8 (Surr)	99.3		% Recovery	09/29/10 03:59

Sample : **CB-2 (35)**

Project Name : **NuStar Vancouver**

Project Number : **E3WR-0028**

Lab Number : 74644-03

Matrix : Water

Sample Date :09/20/2010

Analysis Method: EPA 8260B

Parameter	Measured Value	Method Reporting Limit	Units	Date/Time Analyzed
Dichlorodifluoromethane	< 0.50	0.50	ug/L	09/28/10 22:39
Chloromethane	< 0.50	0.50	ug/L	09/28/10 22:39
Vinyl Chloride	0.66	0.50	ug/L	09/28/10 22:39
Bromomethane	< 20	20	ug/L	09/28/10 22:39
Chloroethane	< 0.50	0.50	ug/L	09/28/10 22:39
Trichlorofluoromethane	< 0.50	0.50	ug/L	09/28/10 22:39
1,1-Dichloroethene	< 0.50	0.50	ug/L	09/28/10 22:39
Methylene Chloride	< 5.0	5.0	ug/L	09/28/10 22:39
trans-1,2-Dichloroethene	< 0.50	0.50	ug/L	09/28/10 22:39
1,1-Dichloroethane	< 0.50	0.50	ug/L	09/28/10 22:39
2,2-Dichloropropane	< 0.50	0.50	ug/L	09/28/10 22:39
cis-1,2-Dichloroethene	35	0.50	ug/L	09/28/10 22:39
Chloroform	< 0.50	0.50	ug/L	09/28/10 22:39
Bromochloromethane	< 0.50	0.50	ug/L	09/28/10 22:39
1,1,1-Trichloroethane	< 0.50	0.50	ug/L	09/28/10 22:39
1,1-Dichloropropene	< 0.50	0.50	ug/L	09/28/10 22:39
1,2-Dichloroethane	< 0.50	0.50	ug/L	09/28/10 22:39
Carbon Tetrachloride	< 0.50	0.50	ug/L	09/28/10 22:39
Benzene	< 0.50	0.50	ug/L	09/28/10 22:39
Trichloroethene	16	0.50	ug/L	09/28/10 22:39
1,2-Dichloropropane	< 0.50	0.50	ug/L	09/28/10 22:39
Bromodichloromethane	< 0.50	0.50	ug/L	09/28/10 22:39
Dibromomethane	< 0.50	0.50	ug/L	09/28/10 22:39
cis-1,3-Dichloropropene	< 0.50	0.50	ug/L	09/28/10 22:39
Toluene	< 0.50	0.50	ug/L	09/28/10 22:39
trans-1,3-Dichloropropene	< 0.50	0.50	ug/L	09/28/10 22:39
1,1,2-Trichloroethane	< 0.50	0.50	ug/L	09/28/10 22:39
1,3-Dichloropropane	< 0.50	0.50	ug/L	09/28/10 22:39
Tetrachloroethene	62	0.50	ug/L	09/28/10 22:39
Dibromochloromethane	< 0.50	0.50	ug/L	09/28/10 22:39
1,2-Dibromoethane	< 0.50	0.50	ug/L	09/28/10 22:39
Chlorobenzene	< 0.50	0.50	ug/L	09/28/10 22:39
1,1,1,2-Tetrachloroethane	< 0.50	0.50	ug/L	09/28/10 22:39
Ethylbenzene	< 0.50	0.50	ug/L	09/28/10 22:39

Sample : **CB-2 (35)**

Project Name : **NuStar Vancouver**

Project Number : **E3WR-0028**

Lab Number : 74644-03

Matrix : Water

Sample Date :09/20/2010

Analysis Method: EPA 8260B

Parameter	Measured Value	Method Reporting Limit	Units	Date/Time Analyzed
P,M-Xylene	< 1.0	1.0	ug/L	09/28/10 22:39
O-Xylene	< 0.50	0.50	ug/L	09/28/10 22:39
Styrene	< 0.50	0.50	ug/L	09/28/10 22:39
Isopropyl benzene	< 0.50	0.50	ug/L	09/28/10 22:39
Bromoform	< 0.50	0.50	ug/L	09/28/10 22:39
1,1,2,2-Tetrachloroethane	< 0.50	0.50	ug/L	09/28/10 22:39
1,2,3-Trichloropropane	< 0.50	0.50	ug/L	09/28/10 22:39
n-Propylbenzene	< 0.50	0.50	ug/L	09/28/10 22:39
Bromobenzene	< 0.50	0.50	ug/L	09/28/10 22:39
1,3,5-Trimethylbenzene	< 0.50	0.50	ug/L	09/28/10 22:39
2+4-Chlorotoluene	< 1.0	1.0	ug/L	09/28/10 22:39
tert-Butylbenzene	< 0.50	0.50	ug/L	09/28/10 22:39
1,2,4-Trimethylbenzene	< 0.50	0.50	ug/L	09/28/10 22:39
sec-Butylbenzene	< 0.50	0.50	ug/L	09/28/10 22:39
p-Isopropyltoluene	< 0.50	0.50	ug/L	09/28/10 22:39
1,3-Dichlorobenzene	< 0.50	0.50	ug/L	09/28/10 22:39
1,4-Dichlorobenzene	< 0.50	0.50	ug/L	09/28/10 22:39
n-Butylbenzene	< 0.50	0.50	ug/L	09/28/10 22:39
1,2-Dichlorobenzene	< 0.50	0.50	ug/L	09/28/10 22:39
1,2-Dibromo-3-chloropropane	< 0.50	0.50	ug/L	09/28/10 22:39
1,2,4-Trichlorobenzene	< 0.50	0.50	ug/L	09/28/10 22:39
Hexachlorobutadiene	< 0.50	0.50	ug/L	09/28/10 22:39
Naphthalene	< 0.50	0.50	ug/L	09/29/10 10:29
1,2,3-Trichlorobenzene	< 0.50	0.50	ug/L	09/28/10 22:39
1,2-Dichloroethane-d4 (Surr)	97.8		% Recovery	09/28/10 22:39
4-Bromofluorobenzene (Surr)	98.5		% Recovery	09/28/10 22:39
Toluene - d8 (Surr)	98.8		% Recovery	09/28/10 22:39

Sample : **CB-2 (45)**

Project Name : **NuStar Vancouver**

Project Number : **E3WR-0028**

Lab Number : 74644-04

Matrix : Water

Sample Date :09/21/2010

Analysis Method: EPA 8260B

Parameter	Measured Value	Method Reporting Limit	Units	Date/Time Analyzed
Dichlorodifluoromethane	< 5.0	5.0	ug/L	09/29/10 05:11
Chloromethane	< 5.0	5.0	ug/L	09/29/10 05:11
Vinyl Chloride	39	5.0	ug/L	09/29/10 05:11
Bromomethane	< 100	100	ug/L	09/29/10 05:11
Chloroethane	< 5.0	5.0	ug/L	09/29/10 05:11
Trichlorofluoromethane	< 5.0	5.0	ug/L	09/29/10 05:11
1,1-Dichloroethene	23	5.0	ug/L	09/29/10 05:11
Methylene Chloride	< 5.0	5.0	ug/L	09/29/10 05:11
trans-1,2-Dichloroethene	8.2	5.0	ug/L	09/29/10 05:11
1,1-Dichloroethane	100	5.0	ug/L	09/29/10 05:11
2,2-Dichloropropane	< 5.0	5.0	ug/L	09/29/10 05:11
cis-1,2-Dichloroethene	770	5.0	ug/L	09/29/10 05:11
Chloroform	< 5.0	5.0	ug/L	09/29/10 05:11
Bromochloromethane	< 5.0	5.0	ug/L	09/29/10 05:11
1,1,1-Trichloroethane	72	5.0	ug/L	09/29/10 05:11
1,1-Dichloropropene	< 5.0	5.0	ug/L	09/29/10 05:11
1,2-Dichloroethane	< 5.0	5.0	ug/L	09/29/10 05:11
Carbon Tetrachloride	< 5.0	5.0	ug/L	09/29/10 05:11
Benzene	< 5.0	5.0	ug/L	09/29/10 05:11
Trichloroethene	1000	5.0	ug/L	09/29/10 05:11
1,2-Dichloropropane	< 5.0	5.0	ug/L	09/29/10 05:11
Bromodichloromethane	< 5.0	5.0	ug/L	09/29/10 05:11
Dibromomethane	< 5.0	5.0	ug/L	09/29/10 05:11
cis-1,3-Dichloropropene	< 5.0	5.0	ug/L	09/29/10 05:11
Toluene	< 5.0	5.0	ug/L	09/29/10 05:11
trans-1,3-Dichloropropene	< 5.0	5.0	ug/L	09/29/10 05:11
1,1,2-Trichloroethane	< 5.0	5.0	ug/L	09/29/10 05:11
1,3-Dichloropropane	< 5.0	5.0	ug/L	09/29/10 05:11
Tetrachloroethene	500	5.0	ug/L	09/29/10 05:11
Dibromochloromethane	< 5.0	5.0	ug/L	09/29/10 05:11
1,2-Dibromoethane	< 5.0	5.0	ug/L	09/29/10 05:11
Chlorobenzene	< 5.0	5.0	ug/L	09/29/10 05:11
1,1,1,2-Tetrachloroethane	< 5.0	5.0	ug/L	09/29/10 05:11
Ethylbenzene	< 5.0	5.0	ug/L	09/29/10 05:11



Report Number : 74644

Date : 10/14/2010

Sample : CB-2 (45)

Project Name : NuStar Vancouver

Project Number : E3WR-0028

Lab Number : 74644-04

Matrix : Water

Sample Date :09/21/2010

Analysis Method: EPA 8260B

Parameter	Measured Value	Method Reporting Limit	Units	Date/Time Analyzed
P,M-Xylene	< 5.0	5.0	ug/L	09/29/10 05:11
O-Xylene	< 5.0	5.0	ug/L	09/29/10 05:11
Styrene	< 5.0	5.0	ug/L	09/29/10 05:11
Isopropyl benzene	< 5.0	5.0	ug/L	09/29/10 05:11
Bromoform	< 5.0	5.0	ug/L	09/29/10 05:11
1,1,2,2-Tetrachloroethane	< 5.0	5.0	ug/L	09/29/10 05:11
1,2,3-Trichloropropane	< 5.0	5.0	ug/L	09/29/10 05:11
n-Propylbenzene	< 5.0	5.0	ug/L	09/29/10 05:11
Bromobenzene	< 5.0	5.0	ug/L	09/29/10 05:11
1,3,5-Trimethylbenzene	< 5.0	5.0	ug/L	09/29/10 05:11
2+4-Chlorotoluene	< 10	10	ug/L	09/29/10 05:11
tert-Butylbenzene	< 5.0	5.0	ug/L	09/29/10 05:11
1,2,4-Trimethylbenzene	< 5.0	5.0	ug/L	09/29/10 05:11
sec-Butylbenzene	< 5.0	5.0	ug/L	09/29/10 05:11
p-Isopropyltoluene	< 5.0	5.0	ug/L	09/29/10 05:11
1,3-Dichlorobenzene	< 5.0	5.0	ug/L	09/29/10 05:11
1,4-Dichlorobenzene	< 5.0	5.0	ug/L	09/29/10 05:11
n-Butylbenzene	< 5.0	5.0	ug/L	09/29/10 05:11
1,2-Dichlorobenzene	< 5.0	5.0	ug/L	09/29/10 05:11
1,2-Dibromo-3-chloropropane	< 5.0	5.0	ug/L	09/29/10 05:11
1,2,4-Trichlorobenzene	< 5.0	5.0	ug/L	09/29/10 05:11
Hexachlorobutadiene	< 5.0	5.0	ug/L	09/29/10 05:11
Naphthalene	< 5.0	5.0	ug/L	09/29/10 05:11
1,2,3-Trichlorobenzene	< 5.0	5.0	ug/L	09/29/10 05:11
1,2-Dichloroethane-d4 (Surr)	98.8		% Recovery	09/29/10 05:11
4-Bromofluorobenzene (Surr)	99.7		% Recovery	09/29/10 05:11
Toluene - d8 (Surr)	99.1		% Recovery	09/29/10 05:11

Sample : **CB-2 (45) DUP**

Project Name : **NuStar Vancouver**

Project Number : **E3WR-0028**

Lab Number : 74644-05

Matrix : Water

Sample Date :09/21/2010

Analysis Method: EPA 8260B

Parameter	Measured Value	Method Reporting Limit	Units	Date/Time Analyzed
Dichlorodifluoromethane	< 7.0	7.0	ug/L	09/29/10 05:45
Chloromethane	< 7.0	7.0	ug/L	09/29/10 05:45
Vinyl Chloride	61	7.0	ug/L	09/29/10 05:45
Bromomethane	< 150	150	ug/L	09/29/10 05:45
Chloroethane	< 7.0	7.0	ug/L	09/29/10 05:45
Trichlorofluoromethane	< 7.0	7.0	ug/L	09/29/10 05:45
1,1-Dichloroethene	36	7.0	ug/L	09/29/10 05:45
Methylene Chloride	< 7.0	7.0	ug/L	09/29/10 05:45
trans-1,2-Dichloroethene	11	7.0	ug/L	09/29/10 05:45
1,1-Dichloroethane	130	7.0	ug/L	09/29/10 05:45
2,2-Dichloropropane	< 7.0	7.0	ug/L	09/29/10 05:45
cis-1,2-Dichloroethene	950	7.0	ug/L	09/29/10 05:45
Chloroform	< 7.0	7.0	ug/L	09/29/10 05:45
Bromochloromethane	< 7.0	7.0	ug/L	09/29/10 05:45
1,1,1-Trichloroethane	110	7.0	ug/L	09/29/10 05:45
1,1-Dichloropropene	< 7.0	7.0	ug/L	09/29/10 05:45
1,2-Dichloroethane	< 7.0	7.0	ug/L	09/29/10 05:45
Carbon Tetrachloride	< 7.0	7.0	ug/L	09/29/10 05:45
Benzene	< 7.0	7.0	ug/L	09/29/10 05:45
Trichloroethene	1800	7.0	ug/L	09/29/10 05:45
1,2-Dichloropropane	< 7.0	7.0	ug/L	09/29/10 05:45
Bromodichloromethane	< 7.0	7.0	ug/L	09/29/10 05:45
Dibromomethane	< 7.0	7.0	ug/L	09/29/10 05:45
cis-1,3-Dichloropropene	< 7.0	7.0	ug/L	09/29/10 05:45
Toluene	< 7.0	7.0	ug/L	09/29/10 05:45
trans-1,3-Dichloropropene	< 7.0	7.0	ug/L	09/29/10 05:45
1,1,2-Trichloroethane	< 7.0	7.0	ug/L	09/29/10 05:45
1,3-Dichloropropane	< 7.0	7.0	ug/L	09/29/10 05:45
Tetrachloroethene	1400	7.0	ug/L	09/29/10 05:45
Dibromochloromethane	< 7.0	7.0	ug/L	09/29/10 05:45
1,2-Dibromoethane	< 7.0	7.0	ug/L	09/29/10 05:45
Chlorobenzene	< 7.0	7.0	ug/L	09/29/10 05:45
1,1,1,2-Tetrachloroethane	< 7.0	7.0	ug/L	09/29/10 05:45
Ethylbenzene	< 7.0	7.0	ug/L	09/29/10 05:45



Report Number : 74644

Date : 10/14/2010

Sample : **CB-2 (45) DUP**

Project Name : **NuStar Vancouver**

Project Number : **E3WR-0028**

Lab Number : 74644-05

Matrix : Water

Sample Date :09/21/2010

Analysis Method: EPA 8260B

Parameter	Measured Value	Method Reporting Limit	Units	Date/Time Analyzed
P,M-Xylene	< 7.0	7.0	ug/L	09/29/10 05:45
O-Xylene	< 7.0	7.0	ug/L	09/29/10 05:45
Styrene	< 7.0	7.0	ug/L	09/29/10 05:45
Isopropyl benzene	< 7.0	7.0	ug/L	09/29/10 05:45
Bromoform	< 7.0	7.0	ug/L	09/29/10 05:45
1,1,2,2-Tetrachloroethane	< 7.0	7.0	ug/L	09/29/10 05:45
1,2,3-Trichloropropane	< 7.0	7.0	ug/L	09/29/10 05:45
n-Propylbenzene	< 7.0	7.0	ug/L	09/29/10 05:45
Bromobenzene	< 7.0	7.0	ug/L	09/29/10 05:45
1,3,5-Trimethylbenzene	< 7.0	7.0	ug/L	09/29/10 05:45
2+4-Chlorotoluene	< 15	15	ug/L	09/29/10 05:45
tert-Butylbenzene	< 7.0	7.0	ug/L	09/29/10 05:45
1,2,4-Trimethylbenzene	< 7.0	7.0	ug/L	09/29/10 05:45
sec-Butylbenzene	< 7.0	7.0	ug/L	09/29/10 05:45
p-Isopropyltoluene	< 7.0	7.0	ug/L	09/29/10 05:45
1,3-Dichlorobenzene	< 7.0	7.0	ug/L	09/29/10 05:45
1,4-Dichlorobenzene	< 7.0	7.0	ug/L	09/29/10 05:45
n-Butylbenzene	< 7.0	7.0	ug/L	09/29/10 05:45
1,2-Dichlorobenzene	< 7.0	7.0	ug/L	09/29/10 05:45
1,2-Dibromo-3-chloropropane	< 7.0	7.0	ug/L	09/29/10 05:45
1,2,4-Trichlorobenzene	< 7.0	7.0	ug/L	09/29/10 05:45
Hexachlorobutadiene	< 7.0	7.0	ug/L	09/29/10 05:45
Naphthalene	< 7.0	7.0	ug/L	09/29/10 05:45
1,2,3-Trichlorobenzene	< 7.0	7.0	ug/L	09/29/10 05:45
1,2-Dichloroethane-d4 (Surr)	97.2		% Recovery	09/29/10 05:45
4-Bromofluorobenzene (Surr)	99.4		% Recovery	09/29/10 05:45
Toluene - d8 (Surr)	99.0		% Recovery	09/29/10 05:45

Sample : **CB-4 (35)**

Project Name : **NuStar Vancouver**

Project Number : **E3WR-0028**

Lab Number : 74644-06

Matrix : Water

Sample Date :09/21/2010

Analysis Method: EPA 8260B

Parameter	Measured Value	Method Reporting Limit	Units	Date/Time Analyzed
Dichlorodifluoromethane	< 4.0	4.0	ug/L	09/29/10 02:48
Chloromethane	< 4.0	4.0	ug/L	09/29/10 02:48
Vinyl Chloride	< 4.0	4.0	ug/L	09/29/10 02:48
Bromomethane	< 70	70	ug/L	09/29/10 02:48
Chloroethane	< 4.0	4.0	ug/L	09/29/10 02:48
Trichlorofluoromethane	< 4.0	4.0	ug/L	09/29/10 02:48
1,1-Dichloroethene	< 4.0	4.0	ug/L	09/29/10 02:48
Methylene Chloride	< 5.0	5.0	ug/L	09/29/10 02:48
trans-1,2-Dichloroethene	6.4	4.0	ug/L	09/29/10 02:48
1,1-Dichloroethane	6.6	4.0	ug/L	09/29/10 02:48
2,2-Dichloropropane	< 4.0	4.0	ug/L	09/29/10 02:48
cis-1,2-Dichloroethene	110	4.0	ug/L	09/29/10 02:48
Chloroform	< 4.0	4.0	ug/L	09/29/10 02:48
Bromochloromethane	< 4.0	4.0	ug/L	09/29/10 02:48
1,1,1-Trichloroethane	4.4	4.0	ug/L	09/29/10 02:48
1,1-Dichloropropene	< 4.0	4.0	ug/L	09/29/10 02:48
1,2-Dichloroethane	< 4.0	4.0	ug/L	09/29/10 02:48
Carbon Tetrachloride	< 4.0	4.0	ug/L	09/29/10 02:48
Benzene	< 4.0	4.0	ug/L	09/29/10 02:48
Trichloroethene	170	4.0	ug/L	09/29/10 02:48
1,2-Dichloropropane	< 4.0	4.0	ug/L	09/29/10 02:48
Bromodichloromethane	< 4.0	4.0	ug/L	09/29/10 02:48
Dibromomethane	< 4.0	4.0	ug/L	09/29/10 02:48
cis-1,3-Dichloropropene	< 4.0	4.0	ug/L	09/29/10 02:48
Toluene	< 4.0	4.0	ug/L	09/29/10 02:48
trans-1,3-Dichloropropene	< 4.0	4.0	ug/L	09/29/10 02:48
1,1,2-Trichloroethane	< 4.0	4.0	ug/L	09/29/10 02:48
1,3-Dichloropropane	< 4.0	4.0	ug/L	09/29/10 02:48
Tetrachloroethene	680	4.0	ug/L	09/29/10 02:48
Dibromochloromethane	< 4.0	4.0	ug/L	09/29/10 02:48
1,2-Dibromoethane	< 4.0	4.0	ug/L	09/29/10 02:48
Chlorobenzene	< 4.0	4.0	ug/L	09/29/10 02:48
1,1,1,2-Tetrachloroethane	< 4.0	4.0	ug/L	09/29/10 02:48
Ethylbenzene	< 4.0	4.0	ug/L	09/29/10 02:48

Sample : **CB-4 (35)**

Project Name : **NuStar Vancouver**

Project Number : **E3WR-0028**

Lab Number : 74644-06

Matrix : Water

Sample Date :09/21/2010

Analysis Method: EPA 8260B

Parameter	Measured Value	Method Reporting Limit	Units	Date/Time Analyzed
P,M-Xylene	< 4.0	4.0	ug/L	09/29/10 02:48
O-Xylene	< 4.0	4.0	ug/L	09/29/10 02:48
Styrene	< 4.0	4.0	ug/L	09/29/10 02:48
Isopropyl benzene	< 4.0	4.0	ug/L	09/29/10 02:48
Bromoform	< 4.0	4.0	ug/L	09/29/10 02:48
1,1,2,2-Tetrachloroethane	< 4.0	4.0	ug/L	09/29/10 02:48
1,2,3-Trichloropropane	< 4.0	4.0	ug/L	09/29/10 02:48
n-Propylbenzene	< 4.0	4.0	ug/L	09/29/10 02:48
Bromobenzene	< 4.0	4.0	ug/L	09/29/10 02:48
1,3,5-Trimethylbenzene	< 4.0	4.0	ug/L	09/29/10 02:48
2+4-Chlorotoluene	< 7.0	7.0	ug/L	09/29/10 02:48
tert-Butylbenzene	< 4.0	4.0	ug/L	09/29/10 02:48
1,2,4-Trimethylbenzene	< 4.0	4.0	ug/L	09/29/10 02:48
sec-Butylbenzene	< 4.0	4.0	ug/L	09/29/10 02:48
p-Isopropyltoluene	< 4.0	4.0	ug/L	09/29/10 02:48
1,3-Dichlorobenzene	< 4.0	4.0	ug/L	09/29/10 02:48
1,4-Dichlorobenzene	< 4.0	4.0	ug/L	09/29/10 02:48
n-Butylbenzene	< 4.0	4.0	ug/L	09/29/10 02:48
1,2-Dichlorobenzene	< 4.0	4.0	ug/L	09/29/10 02:48
1,2-Dibromo-3-chloropropane	< 4.0	4.0	ug/L	09/29/10 02:48
1,2,4-Trichlorobenzene	< 4.0	4.0	ug/L	09/29/10 02:48
Hexachlorobutadiene	< 4.0	4.0	ug/L	09/29/10 02:48
Naphthalene	< 4.0	4.0	ug/L	09/29/10 02:48
1,2,3-Trichlorobenzene	< 4.0	4.0	ug/L	09/29/10 02:48
1,2-Dichloroethane-d4 (Surr)	96.7		% Recovery	09/29/10 02:48
4-Bromofluorobenzene (Surr)	97.4		% Recovery	09/29/10 02:48
Toluene - d8 (Surr)	98.5		% Recovery	09/29/10 02:48

Sample : **CB-4 (45)**

Project Name : **NuStar Vancouver**

Project Number : **E3WR-0028**

Lab Number : 74644-07

Matrix : Water

Sample Date :09/21/2010

Analysis Method: EPA 8260B

Parameter	Measured Value	Method Reporting Limit	Units	Date/Time Analyzed
Dichlorodifluoromethane	< 15	15	ug/L	09/29/10 04:34
Chloromethane	< 15	15	ug/L	09/29/10 04:34
Vinyl Chloride	100	15	ug/L	09/29/10 04:34
Bromomethane	< 250	250	ug/L	09/29/10 04:34
Chloroethane	< 15	15	ug/L	09/29/10 04:34
Trichlorofluoromethane	< 15	15	ug/L	09/29/10 04:34
1,1-Dichloroethene	< 15	15	ug/L	09/29/10 04:34
Methylene Chloride	< 15	15	ug/L	09/29/10 04:34
trans-1,2-Dichloroethene	22	15	ug/L	09/29/10 04:34
1,1-Dichloroethane	41	15	ug/L	09/29/10 04:34
2,2-Dichloropropane	< 15	15	ug/L	09/29/10 04:34
cis-1,2-Dichloroethene	1200	15	ug/L	09/29/10 04:34
Chloroform	< 15	15	ug/L	09/29/10 04:34
Bromochloromethane	< 15	15	ug/L	09/29/10 04:34
1,1,1-Trichloroethane	62	15	ug/L	09/29/10 04:34
1,1-Dichloropropene	< 15	15	ug/L	09/29/10 04:34
1,2-Dichloroethane	< 15	15	ug/L	09/29/10 04:34
Carbon Tetrachloride	< 15	15	ug/L	09/29/10 04:34
Benzene	< 15	15	ug/L	09/29/10 04:34
Trichloroethene	820	15	ug/L	09/29/10 04:34
1,2-Dichloropropane	< 15	15	ug/L	09/29/10 04:34
Bromodichloromethane	< 15	15	ug/L	09/29/10 04:34
Dibromomethane	< 15	15	ug/L	09/29/10 04:34
cis-1,3-Dichloropropene	< 15	15	ug/L	09/29/10 04:34
Toluene	< 15	15	ug/L	09/29/10 04:34
trans-1,3-Dichloropropene	< 15	15	ug/L	09/29/10 04:34
1,1,2-Trichloroethane	< 15	15	ug/L	09/29/10 04:34
1,3-Dichloropropane	< 15	15	ug/L	09/29/10 04:34
Tetrachloroethene	3300	15	ug/L	09/29/10 04:34
Dibromochloromethane	< 15	15	ug/L	09/29/10 04:34
1,2-Dibromoethane	< 15	15	ug/L	09/29/10 04:34
Chlorobenzene	< 15	15	ug/L	09/29/10 04:34
1,1,1,2-Tetrachloroethane	< 15	15	ug/L	09/29/10 04:34
Ethylbenzene	< 15	15	ug/L	09/29/10 04:34

Sample : **CB-4 (45)**

Project Name : **NuStar Vancouver**

Project Number : **E3WR-0028**

Lab Number : 74644-07

Matrix : Water

Sample Date :09/21/2010

Analysis Method: EPA 8260B

Parameter	Measured Value	Method Reporting Limit	Units	Date/Time Analyzed
P,M-Xylene	< 15	15	ug/L	09/29/10 04:34
O-Xylene	< 15	15	ug/L	09/29/10 04:34
Styrene	< 15	15	ug/L	09/29/10 04:34
Isopropyl benzene	< 15	15	ug/L	09/29/10 04:34
Bromoform	< 15	15	ug/L	09/29/10 04:34
1,1,2,2-Tetrachloroethane	< 15	15	ug/L	09/29/10 04:34
1,2,3-Trichloropropane	< 15	15	ug/L	09/29/10 04:34
n-Propylbenzene	< 15	15	ug/L	09/29/10 04:34
Bromobenzene	< 15	15	ug/L	09/29/10 04:34
1,3,5-Trimethylbenzene	< 15	15	ug/L	09/29/10 04:34
2+4-Chlorotoluene	< 25	25	ug/L	09/29/10 04:34
tert-Butylbenzene	< 15	15	ug/L	09/29/10 04:34
1,2,4-Trimethylbenzene	< 15	15	ug/L	09/29/10 04:34
sec-Butylbenzene	< 15	15	ug/L	09/29/10 04:34
p-Isopropyltoluene	< 15	15	ug/L	09/29/10 04:34
1,3-Dichlorobenzene	< 15	15	ug/L	09/29/10 04:34
1,4-Dichlorobenzene	< 15	15	ug/L	09/29/10 04:34
n-Butylbenzene	< 15	15	ug/L	09/29/10 04:34
1,2-Dichlorobenzene	< 15	15	ug/L	09/29/10 04:34
1,2-Dibromo-3-chloropropane	< 15	15	ug/L	09/29/10 04:34
1,2,4-Trichlorobenzene	< 15	15	ug/L	09/29/10 04:34
Hexachlorobutadiene	< 15	15	ug/L	09/29/10 04:34
Naphthalene	< 15	15	ug/L	09/29/10 04:34
1,2,3-Trichlorobenzene	< 15	15	ug/L	09/29/10 04:34
1,2-Dichloroethane-d4 (Surr)	99.6		% Recovery	09/29/10 04:34
4-Bromofluorobenzene (Surr)	102		% Recovery	09/29/10 04:34
Toluene - d8 (Surr)	99.8		% Recovery	09/29/10 04:34

Sample : **Field Blank**

Project Name : **NuStar Vancouver**

Project Number : **E3WR-0028**

Lab Number : 74644-08

Matrix : Water

Sample Date :09/21/2010

Analysis Method: EPA 8260B

Parameter	Measured Value	Method Reporting Limit	Units	Date/Time Analyzed
Dichlorodifluoromethane	< 0.50	0.50	ug/L	09/29/10 01:36
Chloromethane	< 0.50	0.50	ug/L	09/29/10 01:36
Vinyl Chloride	< 0.50	0.50	ug/L	09/29/10 01:36
Bromomethane	< 20	20	ug/L	09/29/10 01:36
Chloroethane	< 0.50	0.50	ug/L	09/29/10 01:36
Trichlorofluoromethane	< 0.50	0.50	ug/L	09/29/10 01:36
1,1-Dichloroethene	< 0.50	0.50	ug/L	09/29/10 01:36
Methylene Chloride	< 5.0	5.0	ug/L	09/29/10 01:36
trans-1,2-Dichloroethene	< 0.50	0.50	ug/L	09/29/10 01:36
1,1-Dichloroethane	< 0.50	0.50	ug/L	09/29/10 01:36
2,2-Dichloropropane	< 0.50	0.50	ug/L	09/29/10 01:36
cis-1,2-Dichloroethene	< 0.50	0.50	ug/L	09/29/10 01:36
Chloroform	< 0.50	0.50	ug/L	09/29/10 01:36
Bromochloromethane	< 0.50	0.50	ug/L	09/29/10 01:36
1,1,1-Trichloroethane	< 0.50	0.50	ug/L	09/29/10 01:36
1,1-Dichloropropene	< 0.50	0.50	ug/L	09/29/10 01:36
1,2-Dichloroethane	< 0.50	0.50	ug/L	09/29/10 01:36
Carbon Tetrachloride	< 0.50	0.50	ug/L	09/29/10 01:36
Benzene	< 0.50	0.50	ug/L	09/29/10 01:36
Trichloroethene	< 0.50	0.50	ug/L	09/29/10 01:36
1,2-Dichloropropane	< 0.50	0.50	ug/L	09/29/10 01:36
Bromodichloromethane	< 0.50	0.50	ug/L	09/29/10 01:36
Dibromomethane	< 0.50	0.50	ug/L	09/29/10 01:36
cis-1,3-Dichloropropene	< 0.50	0.50	ug/L	09/29/10 01:36
Toluene	< 0.50	0.50	ug/L	09/29/10 01:36
trans-1,3-Dichloropropene	< 0.50	0.50	ug/L	09/29/10 01:36
1,1,2-Trichloroethane	< 0.50	0.50	ug/L	09/29/10 01:36
1,3-Dichloropropane	< 0.50	0.50	ug/L	09/29/10 01:36
Tetrachloroethene	< 0.50	0.50	ug/L	09/29/10 01:36
Dibromochloromethane	< 0.50	0.50	ug/L	09/29/10 01:36
1,2-Dibromoethane	< 0.50	0.50	ug/L	09/29/10 01:36
Chlorobenzene	< 0.50	0.50	ug/L	09/29/10 01:36
1,1,1,2-Tetrachloroethane	< 0.50	0.50	ug/L	09/29/10 01:36
Ethylbenzene	< 0.50	0.50	ug/L	09/29/10 01:36

Sample : **Field Blank**

Project Name : **NuStar Vancouver**

Project Number : **E3WR-0028**

Lab Number : 74644-08

Matrix : Water

Sample Date :09/21/2010

Analysis Method: EPA 8260B

Parameter	Measured Value	Method Reporting Limit	Units	Date/Time Analyzed
P,M-Xylene	< 1.0	1.0	ug/L	09/29/10 01:36
O-Xylene	< 0.50	0.50	ug/L	09/29/10 01:36
Styrene	< 0.50	0.50	ug/L	09/29/10 01:36
Isopropyl benzene	< 0.50	0.50	ug/L	09/29/10 01:36
Bromoform	< 0.50	0.50	ug/L	09/29/10 01:36
1,1,2,2-Tetrachloroethane	< 0.50	0.50	ug/L	09/29/10 01:36
1,2,3-Trichloropropane	< 0.50	0.50	ug/L	09/29/10 01:36
n-Propylbenzene	< 0.50	0.50	ug/L	09/29/10 01:36
Bromobenzene	< 0.50	0.50	ug/L	09/29/10 01:36
1,3,5-Trimethylbenzene	< 0.50	0.50	ug/L	09/29/10 01:36
2+4-Chlorotoluene	< 1.0	1.0	ug/L	09/29/10 01:36
tert-Butylbenzene	< 0.50	0.50	ug/L	09/29/10 01:36
1,2,4-Trimethylbenzene	< 0.50	0.50	ug/L	09/29/10 01:36
sec-Butylbenzene	< 0.50	0.50	ug/L	09/29/10 01:36
p-Isopropyltoluene	< 0.50	0.50	ug/L	09/29/10 01:36
1,3-Dichlorobenzene	< 0.50	0.50	ug/L	09/29/10 01:36
1,4-Dichlorobenzene	< 0.50	0.50	ug/L	09/29/10 01:36
n-Butylbenzene	< 0.50	0.50	ug/L	09/29/10 01:36
1,2-Dichlorobenzene	< 0.50	0.50	ug/L	09/29/10 01:36
1,2-Dibromo-3-chloropropane	< 0.50	0.50	ug/L	09/29/10 01:36
1,2,4-Trichlorobenzene	< 0.50	0.50	ug/L	09/29/10 01:36
Hexachlorobutadiene	< 0.50	0.50	ug/L	09/29/10 01:36
Naphthalene	< 0.50	0.50	ug/L	09/29/10 01:36
1,2,3-Trichlorobenzene	< 0.50	0.50	ug/L	09/29/10 01:36
1,2-Dichloroethane-d4 (Surr)	97.7		% Recovery	09/29/10 01:36
4-Bromofluorobenzene (Surr)	97.7		% Recovery	09/29/10 01:36
Toluene - d8 (Surr)	99.2		% Recovery	09/29/10 01:36

Sample : **Field Blank #2**

Project Name : **NuStar Vancouver**

Project Number : **E3WR-0028**

Lab Number : 74644-09

Matrix : Water

Sample Date :09/21/2010

Analysis Method: EPA 8260B

Parameter	Measured Value	Method Reporting Limit	Units	Date/Time Analyzed
Dichlorodifluoromethane	< 0.50	0.50	ug/L	09/23/10 16:17
Chloromethane	< 0.50	0.50	ug/L	09/23/10 16:17
Vinyl Chloride	< 0.50	0.50	ug/L	09/23/10 16:17
Bromomethane	< 20	20	ug/L	09/23/10 16:17
Chloroethane	< 0.50	0.50	ug/L	09/23/10 16:17
Trichlorofluoromethane	< 0.50	0.50	ug/L	09/23/10 16:17
1,1-Dichloroethene	< 0.50	0.50	ug/L	09/23/10 16:17
Methylene Chloride	< 5.0	5.0	ug/L	09/23/10 16:17
trans-1,2-Dichloroethene	< 0.50	0.50	ug/L	09/23/10 16:17
1,1-Dichloroethane	< 0.50	0.50	ug/L	09/23/10 16:17
2,2-Dichloropropane	< 0.50	0.50	ug/L	09/23/10 16:17
cis-1,2-Dichloroethene	< 0.50	0.50	ug/L	09/23/10 16:17
Chloroform	< 0.50	0.50	ug/L	09/23/10 16:17
Bromochloromethane	< 0.50	0.50	ug/L	09/23/10 16:17
1,1,1-Trichloroethane	< 0.50	0.50	ug/L	09/23/10 16:17
1,1-Dichloropropene	< 0.50	0.50	ug/L	09/23/10 16:17
1,2-Dichloroethane	< 0.50	0.50	ug/L	09/23/10 16:17
Carbon Tetrachloride	< 0.50	0.50	ug/L	09/23/10 16:17
Benzene	< 0.50	0.50	ug/L	09/23/10 16:17
Trichloroethene	< 0.50	0.50	ug/L	09/23/10 16:17
1,2-Dichloropropane	< 0.50	0.50	ug/L	09/23/10 16:17
Bromodichloromethane	< 0.50	0.50	ug/L	09/23/10 16:17
Dibromomethane	< 0.50	0.50	ug/L	09/23/10 16:17
cis-1,3-Dichloropropene	< 0.50	0.50	ug/L	09/23/10 16:17
Toluene	< 0.50	0.50	ug/L	09/23/10 16:17
trans-1,3-Dichloropropene	< 0.50	0.50	ug/L	09/23/10 16:17
1,1,2-Trichloroethane	< 0.50	0.50	ug/L	09/23/10 16:17
1,3-Dichloropropane	< 0.50	0.50	ug/L	09/23/10 16:17
Tetrachloroethene	< 0.50	0.50	ug/L	09/23/10 16:17
Dibromochloromethane	< 0.50	0.50	ug/L	09/23/10 16:17
1,2-Dibromoethane	< 0.50	0.50	ug/L	09/23/10 16:17
Chlorobenzene	< 0.50	0.50	ug/L	09/23/10 16:17
1,1,1,2-Tetrachloroethane	< 0.50	0.50	ug/L	09/23/10 16:17
Ethylbenzene	< 0.50	0.50	ug/L	09/23/10 16:17

Sample : **Field Blank #2**

Project Name : **NuStar Vancouver**

Project Number : **E3WR-0028**

Lab Number : 74644-09

Matrix : Water

Sample Date :09/21/2010

Analysis Method: EPA 8260B

Parameter	Measured Value	Method Reporting Limit	Units	Date/Time Analyzed
P,M-Xylene	< 1.0	1.0	ug/L	09/23/10 16:17
O-Xylene	< 0.50	0.50	ug/L	09/23/10 16:17
Styrene	< 0.50	0.50	ug/L	09/23/10 16:17
Isopropyl benzene	< 0.50	0.50	ug/L	09/23/10 16:17
Bromoform	< 0.50	0.50	ug/L	09/23/10 16:17
1,1,2,2-Tetrachloroethane	< 0.50	0.50	ug/L	09/29/10 02:14
1,2,3-Trichloropropane	< 0.50	0.50	ug/L	09/23/10 16:17
n-Propylbenzene	< 0.50	0.50	ug/L	09/23/10 16:17
Bromobenzene	< 0.50	0.50	ug/L	09/23/10 16:17
1,3,5-Trimethylbenzene	< 0.50	0.50	ug/L	09/23/10 16:17
2+4-Chlorotoluene	< 1.0	1.0	ug/L	09/23/10 16:17
tert-Butylbenzene	< 0.50	0.50	ug/L	09/23/10 16:17
1,2,4-Trimethylbenzene	< 0.50	0.50	ug/L	09/23/10 16:17
sec-Butylbenzene	< 0.50	0.50	ug/L	09/23/10 16:17
p-Isopropyltoluene	< 0.50	0.50	ug/L	09/23/10 16:17
1,3-Dichlorobenzene	< 0.50	0.50	ug/L	09/23/10 16:17
1,4-Dichlorobenzene	< 0.50	0.50	ug/L	09/23/10 16:17
n-Butylbenzene	< 0.50	0.50	ug/L	09/23/10 16:17
1,2-Dichlorobenzene	< 0.50	0.50	ug/L	09/23/10 16:17
1,2-Dibromo-3-chloropropane	< 0.50	0.50	ug/L	09/23/10 16:17
1,2,4-Trichlorobenzene	< 0.50	0.50	ug/L	09/23/10 16:17
Hexachlorobutadiene	< 0.50	0.50	ug/L	09/23/10 16:17
Naphthalene	< 0.50	0.50	ug/L	09/23/10 16:17
1,2,3-Trichlorobenzene	< 0.50	0.50	ug/L	09/23/10 16:17
1,2-Dichloroethane-d4 (Surr)	99.9		% Recovery	09/23/10 16:17
4-Bromofluorobenzene (Surr)	98.1		% Recovery	09/23/10 16:17
Toluene - d8 (Surr)	98.8		% Recovery	09/23/10 16:17

Sample : CB-3 (35)

Project Name : NuStar Vancouver

Project Number : E3WR-0028

Lab Number : 74644-10

Matrix : Water

Sample Date :09/21/2010

Analysis Method: EPA 8260B

Parameter	Measured Value	Method Reporting Limit	Units	Date/Time Analyzed
Dichlorodifluoromethane	< 4.0	4.0	ug/L	09/29/10 01:37
Chloromethane	< 4.0	4.0	ug/L	09/29/10 01:37
Vinyl Chloride	< 4.0	4.0	ug/L	09/29/10 01:37
Bromomethane	< 70	70	ug/L	09/29/10 01:37
Chloroethane	< 4.0	4.0	ug/L	09/29/10 01:37
Trichlorofluoromethane	< 4.0	4.0	ug/L	09/29/10 01:37
1,1-Dichloroethene	< 4.0	4.0	ug/L	09/29/10 01:37
Methylene Chloride	< 5.0	5.0	ug/L	09/29/10 01:37
trans-1,2-Dichloroethene	< 4.0	4.0	ug/L	09/29/10 01:37
1,1-Dichloroethane	9.0	4.0	ug/L	09/29/10 01:37
2,2-Dichloropropane	< 4.0	4.0	ug/L	09/29/10 01:37
cis-1,2-Dichloroethene	220	4.0	ug/L	09/29/10 01:37
Chloroform	< 4.0	4.0	ug/L	09/29/10 01:37
Bromochloromethane	< 4.0	4.0	ug/L	09/29/10 01:37
1,1,1-Trichloroethane	8.8	4.0	ug/L	09/29/10 01:37
1,1-Dichloropropene	< 4.0	4.0	ug/L	09/29/10 01:37
1,2-Dichloroethane	< 4.0	4.0	ug/L	09/29/10 01:37
Carbon Tetrachloride	< 4.0	4.0	ug/L	09/29/10 01:37
Benzene	< 4.0	4.0	ug/L	09/29/10 01:37
Trichloroethene	240	4.0	ug/L	09/29/10 01:37
1,2-Dichloropropane	< 4.0	4.0	ug/L	09/29/10 01:37
Bromodichloromethane	< 4.0	4.0	ug/L	09/29/10 01:37
Dibromomethane	< 4.0	4.0	ug/L	09/29/10 01:37
cis-1,3-Dichloropropene	< 4.0	4.0	ug/L	09/29/10 01:37
Toluene	< 4.0	4.0	ug/L	09/29/10 01:37
trans-1,3-Dichloropropene	< 4.0	4.0	ug/L	09/29/10 01:37
1,1,2-Trichloroethane	< 4.0	4.0	ug/L	09/29/10 01:37
1,3-Dichloropropane	< 4.0	4.0	ug/L	09/29/10 01:37
Tetrachloroethene	940	4.0	ug/L	09/29/10 01:37
Dibromochloromethane	< 4.0	4.0	ug/L	09/29/10 01:37
1,2-Dibromoethane	< 4.0	4.0	ug/L	09/29/10 01:37
Chlorobenzene	< 4.0	4.0	ug/L	09/29/10 01:37
1,1,1,2-Tetrachloroethane	< 4.0	4.0	ug/L	09/29/10 01:37
Ethylbenzene	< 4.0	4.0	ug/L	09/29/10 01:37

Sample : **CB-3 (35)**

Project Name : **NuStar Vancouver**

Project Number : **E3WR-0028**

Lab Number : 74644-10

Matrix : Water

Sample Date :09/21/2010

Analysis Method: EPA 8260B

Parameter	Measured Value	Method Reporting Limit	Units	Date/Time Analyzed
P,M-Xylene	< 4.0	4.0	ug/L	09/29/10 01:37
O-Xylene	< 4.0	4.0	ug/L	09/29/10 01:37
Styrene	< 4.0	4.0	ug/L	09/29/10 01:37
Isopropyl benzene	< 4.0	4.0	ug/L	09/29/10 01:37
Bromoform	< 4.0	4.0	ug/L	09/29/10 01:37
1,1,2,2-Tetrachloroethane	< 4.0	4.0	ug/L	09/29/10 01:37
1,2,3-Trichloropropane	< 4.0	4.0	ug/L	09/29/10 01:37
n-Propylbenzene	< 4.0	4.0	ug/L	09/29/10 01:37
Bromobenzene	< 4.0	4.0	ug/L	09/29/10 01:37
1,3,5-Trimethylbenzene	< 4.0	4.0	ug/L	09/29/10 01:37
2+4-Chlorotoluene	< 7.0	7.0	ug/L	09/29/10 01:37
tert-Butylbenzene	< 4.0	4.0	ug/L	09/29/10 01:37
1,2,4-Trimethylbenzene	< 4.0	4.0	ug/L	09/29/10 01:37
sec-Butylbenzene	< 4.0	4.0	ug/L	09/29/10 01:37
p-Isopropyltoluene	< 4.0	4.0	ug/L	09/29/10 01:37
1,3-Dichlorobenzene	< 4.0	4.0	ug/L	09/29/10 01:37
1,4-Dichlorobenzene	< 4.0	4.0	ug/L	09/29/10 01:37
n-Butylbenzene	< 4.0	4.0	ug/L	09/29/10 01:37
1,2-Dichlorobenzene	< 4.0	4.0	ug/L	09/29/10 01:37
1,2-Dibromo-3-chloropropane	< 4.0	4.0	ug/L	09/29/10 01:37
1,2,4-Trichlorobenzene	< 4.0	4.0	ug/L	09/29/10 01:37
Hexachlorobutadiene	< 4.0	4.0	ug/L	09/29/10 01:37
Naphthalene	< 4.0	4.0	ug/L	09/29/10 01:37
1,2,3-Trichlorobenzene	< 4.0	4.0	ug/L	09/29/10 01:37
1,2-Dichloroethane-d4 (Surr)	105		% Recovery	09/29/10 01:37
4-Bromofluorobenzene (Surr)	99.1		% Recovery	09/29/10 01:37
Toluene - d8 (Surr)	100		% Recovery	09/29/10 01:37



Report Number : 74644

Date : 10/14/2010

Sample : TRIP BLANK

Project Name : NuStar Vancouver

Project Number : E3WR-0028

Lab Number : 74644-11

Matrix : Water

Sample Date :09/21/2010

Analysis Method: EPA 8260B

Parameter	Measured Value	Method Reporting Limit	Units	Date/Time Analyzed
Dichlorodifluoromethane	< 0.50	0.50	ug/L	09/29/10 01:03
Chloromethane	< 0.50	0.50	ug/L	09/29/10 01:03
Vinyl Chloride	< 0.50	0.50	ug/L	09/29/10 01:03
Bromomethane	< 20	20	ug/L	09/29/10 01:03
Chloroethane	< 0.50	0.50	ug/L	09/29/10 01:03
Trichlorofluoromethane	< 0.50	0.50	ug/L	09/29/10 01:03
1,1-Dichloroethene	< 0.50	0.50	ug/L	09/29/10 01:03
Methylene Chloride	< 5.0	5.0	ug/L	09/29/10 01:03
trans-1,2-Dichloroethene	< 0.50	0.50	ug/L	09/29/10 01:03
1,1-Dichloroethane	< 0.50	0.50	ug/L	09/29/10 01:03
2,2-Dichloropropane	< 0.50	0.50	ug/L	09/29/10 01:03
cis-1,2-Dichloroethene	< 0.50	0.50	ug/L	09/29/10 01:03
Chloroform	< 0.50	0.50	ug/L	09/29/10 01:03
Bromochloromethane	< 0.50	0.50	ug/L	09/29/10 01:03
1,1,1-Trichloroethane	< 0.50	0.50	ug/L	09/29/10 01:03
1,1-Dichloropropene	< 0.50	0.50	ug/L	09/29/10 01:03
1,2-Dichloroethane	< 0.50	0.50	ug/L	09/29/10 01:03
Carbon Tetrachloride	< 0.50	0.50	ug/L	09/29/10 01:03
Benzene	< 0.50	0.50	ug/L	09/29/10 01:03
Trichloroethene	< 0.50	0.50	ug/L	09/29/10 01:03
1,2-Dichloropropane	< 0.50	0.50	ug/L	09/29/10 01:03
Bromodichloromethane	< 0.50	0.50	ug/L	09/29/10 01:03
Dibromomethane	< 0.50	0.50	ug/L	09/29/10 01:03
cis-1,3-Dichloropropene	< 0.50	0.50	ug/L	09/29/10 01:03
Toluene	< 0.50	0.50	ug/L	09/29/10 01:03
trans-1,3-Dichloropropene	< 0.50	0.50	ug/L	09/29/10 01:03
1,1,2-Trichloroethane	< 0.50	0.50	ug/L	09/29/10 01:03
1,3-Dichloropropane	< 0.50	0.50	ug/L	09/29/10 01:03
Tetrachloroethene	< 0.50	0.50	ug/L	09/29/10 01:03
Dibromochloromethane	< 0.50	0.50	ug/L	09/29/10 01:03
1,2-Dibromoethane	< 0.50	0.50	ug/L	09/29/10 01:03
Chlorobenzene	< 0.50	0.50	ug/L	09/29/10 01:03
1,1,1,2-Tetrachloroethane	< 0.50	0.50	ug/L	09/29/10 01:03
Ethylbenzene	< 0.50	0.50	ug/L	09/29/10 01:03

Sample : **TRIP BLANK**

Project Name : **NuStar Vancouver**

Project Number : **E3WR-0028**

Lab Number : 74644-11

Matrix : Water

Sample Date :09/21/2010

Analysis Method: EPA 8260B

Parameter	Measured Value	Method Reporting Limit	Units	Date/Time Analyzed
P,M-Xylene	< 1.0	1.0	ug/L	09/29/10 01:03
O-Xylene	< 0.50	0.50	ug/L	09/29/10 01:03
Styrene	< 0.50	0.50	ug/L	09/29/10 01:03
Isopropyl benzene	< 0.50	0.50	ug/L	09/29/10 01:03
Bromoform	< 0.50	0.50	ug/L	09/29/10 01:03
1,1,2,2-Tetrachloroethane	< 0.50	0.50	ug/L	09/29/10 01:03
1,2,3-Trichloropropane	< 0.50	0.50	ug/L	09/29/10 01:03
n-Propylbenzene	< 0.50	0.50	ug/L	09/29/10 01:03
Bromobenzene	< 0.50	0.50	ug/L	09/29/10 01:03
1,3,5-Trimethylbenzene	< 0.50	0.50	ug/L	09/29/10 01:03
2+4-Chlorotoluene	< 1.0	1.0	ug/L	09/29/10 01:03
tert-Butylbenzene	< 0.50	0.50	ug/L	09/29/10 01:03
1,2,4-Trimethylbenzene	< 0.50	0.50	ug/L	09/29/10 01:03
sec-Butylbenzene	< 0.50	0.50	ug/L	09/29/10 01:03
p-Isopropyltoluene	< 0.50	0.50	ug/L	09/29/10 01:03
1,3-Dichlorobenzene	< 0.50	0.50	ug/L	09/29/10 01:03
1,4-Dichlorobenzene	< 0.50	0.50	ug/L	09/29/10 01:03
n-Butylbenzene	< 0.50	0.50	ug/L	09/29/10 01:03
1,2-Dichlorobenzene	< 0.50	0.50	ug/L	09/29/10 01:03
1,2-Dibromo-3-chloropropane	< 0.50	0.50	ug/L	09/29/10 01:03
1,2,4-Trichlorobenzene	< 0.50	0.50	ug/L	09/29/10 01:03
Hexachlorobutadiene	< 0.50	0.50	ug/L	09/29/10 01:03
Naphthalene	< 0.50	0.50	ug/L	09/29/10 01:03
1,2,3-Trichlorobenzene	< 0.50	0.50	ug/L	09/29/10 01:03
1,2-Dichloroethane-d4 (Surr)	102		% Recovery	09/29/10 01:03
4-Bromofluorobenzene (Surr)	98.8		% Recovery	09/29/10 01:03
Toluene - d8 (Surr)	100		% Recovery	09/29/10 01:03



Report Number : 74644

Date : 10/14/2010

Project Name : **NuStar Vancouver**

Project Number : **E3WR-0028**

Sample : **CB-3 (35)**

Matrix : Water

Lab Number : 74644-10

Sample Date :09/21/2010

Parameter	Measured Value	Method Reporting Limit	Units	Analysis Method	Date/Time Analyzed
Chloride	8.6	1.0	mg/L	EPA 300.0	09/22/10 20:20
Nitrate as NO3	580	44	mg/L	EPA 300.0	09/23/10 09:27
Nitrite as NO2	2.0	0.50	mg/L	EPA 300.0	09/22/10 20:20
Sulfate	80	1.0	mg/L	EPA 300.0	09/24/10 12:02
Iron	320	0.10	mg/L	EPA 6010B	09/29/10 11:09
Manganese	5.8	0.0050	mg/L	EPA 6010B	09/29/10 11:09
Potassium	61	0.50	mg/L	EPA 6010B	09/29/10 11:09

QC Report : Method Blank Data

Project Name : **NuStar Vancouver**

Project Number : **E3WR-0028**

Parameter	Measured Value	Method Reporting Limit	Units	Analysis Method	Date Analyzed	Parameter	Measured Value	Method Reporting Limit	Units	Analysis Method	Date Analyzed
Iron	< 0.10	0.10	mg/L	EPA 6010B	09/29/2010	Chlorobenzene	< 0.50	0.50	ug/L	EPA 8260B	09/28/2010
Manganese	< 0.0050	0.0050	mg/L	EPA 6010B	09/29/2010	1,1,1,2-Tetrachloroethane	< 0.50	0.50	ug/L	EPA 8260B	09/28/2010
Potassium	< 0.50	0.50	mg/L	EPA 6010B	09/29/2010	Ethylbenzene	< 0.50	0.50	ug/L	EPA 8260B	09/28/2010
Dichlorodifluoromethane	< 0.50	0.50	ug/L	EPA 8260B	09/28/2010	P,M-Xylene	< 1.0	1.0	ug/L	EPA 8260B	09/28/2010
Chloromethane	< 0.50	0.50	ug/L	EPA 8260B	09/28/2010	O-Xylene	< 0.50	0.50	ug/L	EPA 8260B	09/28/2010
Vinyl Chloride	< 0.50	0.50	ug/L	EPA 8260B	09/28/2010	Styrene	< 0.50	0.50	ug/L	EPA 8260B	09/28/2010
Bromomethane	< 20	20	ug/L	EPA 8260B	09/28/2010	Isopropyl benzene	< 0.50	0.50	ug/L	EPA 8260B	09/28/2010
Chloroethane	< 0.50	0.50	ug/L	EPA 8260B	09/28/2010	Bromoform	< 0.50	0.50	ug/L	EPA 8260B	09/28/2010
Trichlorofluoromethane	< 0.50	0.50	ug/L	EPA 8260B	09/28/2010	1,1,2,2-Tetrachloroethane	< 0.50	0.50	ug/L	EPA 8260B	09/28/2010
1,1-Dichloroethene	< 0.50	0.50	ug/L	EPA 8260B	09/28/2010	1,2,3-Trichloropropane	< 0.50	0.50	ug/L	EPA 8260B	09/28/2010
Methylene Chloride	< 5.0	5.0	ug/L	EPA 8260B	09/28/2010	n-Propylbenzene	< 0.50	0.50	ug/L	EPA 8260B	09/28/2010
trans-1,2-Dichloroethene	< 0.50	0.50	ug/L	EPA 8260B	09/28/2010	Bromobenzene	< 0.50	0.50	ug/L	EPA 8260B	09/28/2010
1,1-Dichloroethane	< 0.50	0.50	ug/L	EPA 8260B	09/28/2010	1,3,5-Trimethylbenzene	< 0.50	0.50	ug/L	EPA 8260B	09/28/2010
2,2-Dichloropropane	< 0.50	0.50	ug/L	EPA 8260B	09/28/2010	2+4-Chlorotoluene	< 1.0	1.0	ug/L	EPA 8260B	09/28/2010
cis-1,2-Dichloroethene	< 0.50	0.50	ug/L	EPA 8260B	09/28/2010	tert-Butylbenzene	< 0.50	0.50	ug/L	EPA 8260B	09/28/2010
Chloroform	< 0.50	0.50	ug/L	EPA 8260B	09/28/2010	1,2,4-Trimethylbenzene	< 0.50	0.50	ug/L	EPA 8260B	09/28/2010
Bromochloromethane	< 0.50	0.50	ug/L	EPA 8260B	09/28/2010	sec-Butylbenzene	< 0.50	0.50	ug/L	EPA 8260B	09/28/2010
1,1,1-Trichloroethane	< 0.50	0.50	ug/L	EPA 8260B	09/28/2010	p-Isopropyltoluene	< 0.50	0.50	ug/L	EPA 8260B	09/28/2010
1,1-Dichloropropene	< 0.50	0.50	ug/L	EPA 8260B	09/28/2010	1,3-Dichlorobenzene	< 0.50	0.50	ug/L	EPA 8260B	09/28/2010
1,2-Dichloroethane	< 0.50	0.50	ug/L	EPA 8260B	09/28/2010	1,4-Dichlorobenzene	< 0.50	0.50	ug/L	EPA 8260B	09/28/2010
Carbon Tetrachloride	< 0.50	0.50	ug/L	EPA 8260B	09/28/2010	n-Butylbenzene	< 0.50	0.50	ug/L	EPA 8260B	09/28/2010
Benzene	< 0.50	0.50	ug/L	EPA 8260B	09/28/2010	1,2-Dichlorobenzene	< 0.50	0.50	ug/L	EPA 8260B	09/28/2010
Trichloroethene	< 0.50	0.50	ug/L	EPA 8260B	09/28/2010	1,2-Dibromo-3-chloropropane	< 0.50	0.50	ug/L	EPA 8260B	09/28/2010
1,2-Dichloropropane	< 0.50	0.50	ug/L	EPA 8260B	09/28/2010	1,2,4-Trichlorobenzene	< 0.50	0.50	ug/L	EPA 8260B	09/28/2010
Bromodichloromethane	< 0.50	0.50	ug/L	EPA 8260B	09/28/2010	Hexachlorobutadiene	< 0.50	0.50	ug/L	EPA 8260B	09/28/2010
Dibromomethane	< 0.50	0.50	ug/L	EPA 8260B	09/28/2010	Naphthalene	< 0.50	0.50	ug/L	EPA 8260B	09/28/2010
cis-1,3-Dichloropropene	< 0.50	0.50	ug/L	EPA 8260B	09/28/2010	1,2,3-Trichlorobenzene	< 0.50	0.50	ug/L	EPA 8260B	09/28/2010
Toluene	< 0.50	0.50	ug/L	EPA 8260B	09/28/2010	1,2-Dichloroethane-d4 (Surr)	102		%	EPA 8260B	09/28/2010
trans-1,3-Dichloropropene	< 0.50	0.50	ug/L	EPA 8260B	09/28/2010	4-Bromofluorobenzene (Surr)	100		%	EPA 8260B	09/28/2010
1,1,2-Trichloroethane	< 0.50	0.50	ug/L	EPA 8260B	09/28/2010	Toluene - d8 (Surr)	99.3		%	EPA 8260B	09/28/2010
1,3-Dichloropropane	< 0.50	0.50	ug/L	EPA 8260B	09/28/2010						
Tetrachloroethene	< 0.50	0.50	ug/L	EPA 8260B	09/28/2010						
Dibromochloromethane	< 0.50	0.50	ug/L	EPA 8260B	09/28/2010						
1,2-Dibromoethane	< 0.50	0.50	ug/L	EPA 8260B	09/28/2010						

QC Report : Method Blank Data

Project Name : NuStar Vancouver

Project Number : E3WR-0028

Parameter	Measured Value	Method Reporting Limit	Units	Analysis Method	Date Analyzed	Parameter	Measured Value	Method Reporting Limit	Units	Analysis Method	Date Analyzed
Dichlorodifluoromethane	< 0.50	0.50	ug/L	EPA 8260B	09/23/2010	O-Xylene	< 0.50	0.50	ug/L	EPA 8260B	09/23/2010
Chloromethane	< 0.50	0.50	ug/L	EPA 8260B	09/23/2010	Styrene	< 0.50	0.50	ug/L	EPA 8260B	09/23/2010
Vinyl Chloride	< 0.50	0.50	ug/L	EPA 8260B	09/23/2010	Isopropyl benzene	< 0.50	0.50	ug/L	EPA 8260B	09/23/2010
Bromomethane	< 20	20	ug/L	EPA 8260B	09/23/2010	Bromoform	< 0.50	0.50	ug/L	EPA 8260B	09/23/2010
Chloroethane	< 0.50	0.50	ug/L	EPA 8260B	09/23/2010	1,2,3-Trichloropropane	< 0.50	0.50	ug/L	EPA 8260B	09/23/2010
Trichlorofluoromethane	< 0.50	0.50	ug/L	EPA 8260B	09/23/2010	n-Propylbenzene	< 0.50	0.50	ug/L	EPA 8260B	09/23/2010
1,1-Dichloroethene	< 0.50	0.50	ug/L	EPA 8260B	09/23/2010	Bromobenzene	< 0.50	0.50	ug/L	EPA 8260B	09/23/2010
Methylene Chloride	< 5.0	5.0	ug/L	EPA 8260B	09/23/2010	1,3,5-Trimethylbenzene	< 0.50	0.50	ug/L	EPA 8260B	09/23/2010
trans-1,2-Dichloroethene	< 0.50	0.50	ug/L	EPA 8260B	09/23/2010	2+4-Chlorotoluene	< 1.0	1.0	ug/L	EPA 8260B	09/23/2010
1,1-Dichloroethane	< 0.50	0.50	ug/L	EPA 8260B	09/23/2010	tert-Butylbenzene	< 0.50	0.50	ug/L	EPA 8260B	09/23/2010
2,2-Dichloropropane	< 0.50	0.50	ug/L	EPA 8260B	09/23/2010	1,2,4-Trimethylbenzene	< 0.50	0.50	ug/L	EPA 8260B	09/23/2010
cis-1,2-Dichloroethene	< 0.50	0.50	ug/L	EPA 8260B	09/23/2010	sec-Butylbenzene	< 0.50	0.50	ug/L	EPA 8260B	09/23/2010
Chloroform	< 0.50	0.50	ug/L	EPA 8260B	09/23/2010	p-Isopropyltoluene	< 0.50	0.50	ug/L	EPA 8260B	09/23/2010
Bromochloromethane	< 0.50	0.50	ug/L	EPA 8260B	09/23/2010	1,3-Dichlorobenzene	< 0.50	0.50	ug/L	EPA 8260B	09/23/2010
1,1,1-Trichloroethane	< 0.50	0.50	ug/L	EPA 8260B	09/23/2010	1,4-Dichlorobenzene	< 0.50	0.50	ug/L	EPA 8260B	09/23/2010
1,1-Dichloropropene	< 0.50	0.50	ug/L	EPA 8260B	09/23/2010	n-Butylbenzene	< 0.50	0.50	ug/L	EPA 8260B	09/23/2010
1,2-Dichloroethane	< 0.50	0.50	ug/L	EPA 8260B	09/23/2010	1,2-Dichlorobenzene	< 0.50	0.50	ug/L	EPA 8260B	09/23/2010
Carbon Tetrachloride	< 0.50	0.50	ug/L	EPA 8260B	09/23/2010	1,2-Dibromo-3-chloropropane	< 0.50	0.50	ug/L	EPA 8260B	09/23/2010
Benzene	< 0.50	0.50	ug/L	EPA 8260B	09/23/2010	1,2,4-Trichlorobenzene	< 0.50	0.50	ug/L	EPA 8260B	09/23/2010
Trichloroethene	< 0.50	0.50	ug/L	EPA 8260B	09/23/2010	Hexachlorobutadiene	< 0.50	0.50	ug/L	EPA 8260B	09/23/2010
1,2-Dichloropropane	< 0.50	0.50	ug/L	EPA 8260B	09/23/2010	Naphthalene	< 0.50	0.50	ug/L	EPA 8260B	09/23/2010
Bromodichloromethane	< 0.50	0.50	ug/L	EPA 8260B	09/23/2010	1,2,3-Trichlorobenzene	< 0.50	0.50	ug/L	EPA 8260B	09/23/2010
Dibromomethane	< 0.50	0.50	ug/L	EPA 8260B	09/23/2010	1,2-Dichloroethane-d4 (Surr)	102		%	EPA 8260B	09/23/2010
cis-1,3-Dichloropropene	< 0.50	0.50	ug/L	EPA 8260B	09/23/2010	4-Bromofluorobenzene (Surr)	102		%	EPA 8260B	09/23/2010
Toluene	< 0.50	0.50	ug/L	EPA 8260B	09/23/2010	Toluene - d8 (Surr)	95.9		%	EPA 8260B	09/23/2010
trans-1,3-Dichloropropene	< 0.50	0.50	ug/L	EPA 8260B	09/23/2010						
1,1,2-Trichloroethane	< 0.50	0.50	ug/L	EPA 8260B	09/23/2010						
1,3-Dichloropropane	< 0.50	0.50	ug/L	EPA 8260B	09/23/2010						
Tetrachloroethene	< 0.50	0.50	ug/L	EPA 8260B	09/23/2010						
Dibromochloromethane	< 0.50	0.50	ug/L	EPA 8260B	09/23/2010						
1,2-Dibromoethane	< 0.50	0.50	ug/L	EPA 8260B	09/23/2010						
Chlorobenzene	< 0.50	0.50	ug/L	EPA 8260B	09/23/2010						
1,1,1,2-Tetrachloroethane	< 0.50	0.50	ug/L	EPA 8260B	09/23/2010						
Ethylbenzene	< 0.50	0.50	ug/L	EPA 8260B	09/23/2010						
P,M-Xylene	< 1.0	1.0	ug/L	EPA 8260B	09/23/2010						

Report Number : 74644

Date : 10/14/2010

QC Report : Method Blank Data

Project Name : **NuStar Vancouver**

Project Number : **E3WR-0028**

<u>Parameter</u>	<u>Measured Value</u>	<u>Method Reporting Limit</u>	<u>Units</u>	<u>Analysis Method</u>	<u>Date Analyzed</u>
Chloride	< 0.50	0.50	mg/L	EPA 300.0	09/23/2010
Nitrite as NO2	< 0.50	0.50	mg/L	EPA 300.0	09/23/2010
Nitrate as NO3	< 0.50	0.50	mg/L	EPA 300.0	09/23/2010
Sulfate	< 0.50	0.50	mg/L	EPA 300.0	09/24/2010

<u>Parameter</u>	<u>Measured Value</u>	<u>Method Reporting Limit</u>	<u>Units</u>	<u>Analysis Method</u>	<u>Date Analyzed</u>
------------------	-----------------------	-------------------------------	--------------	------------------------	----------------------

QC Report : Matrix Spike/ Matrix Spike Duplicate

Project Name : **NuStar Vancouver**

Project Number : **E3WR-0028**

Parameter	Spiked Sample	Sample Value	Spike Level	Spike Dup. Level	Spiked Sample Value	Duplicate Spiked Sample Value	Units	Analysis Method	Date Analyzed	Spiked Sample Percent Recov.	Duplicate Spiked Sample Percent Recov.	Relative Percent Diff.	Spiked Sample Percent Recov. Limit	Relative Percent Diff. Limit
Iron	74669-02	0.53	0.400	0.400	0.951	0.927	mg/L	EPA 6010B	9/29/10	104	98.5	2.54	75-125	20
Manganese	74669-02	0.55	0.400	0.400	0.943	0.926	mg/L	EPA 6010B	9/29/10	97.8	93.4	1.87	75-125	20
Potassium	74669-02	1.3	4.00	4.00	5.42	5.37	mg/L	EPA 6010B	9/29/10	103	102	1.02	75-125	20
1,1,1,2-Tetrachloroethane	74644-03	<0.50	39.4	39.9	42.5	42.3	ug/L	EPA 8260B	9/28/10	108	106	1.80	70.0-130	25
1,1,1-Trichloroethane	74644-03	<0.50	39.4	39.9	41.3	41.7	ug/L	EPA 8260B	9/28/10	105	104	0.387	70.0-130	25
1,1,2,2-Tetrachloroethane	74644-03	<0.50	39.4	39.9	40.8	41.4	ug/L	EPA 8260B	9/28/10	104	104	0.0850	80-121	25
1,1,2-Trichloroethane	74644-03	<0.50	39.4	39.9	39.1	40.2	ug/L	EPA 8260B	9/28/10	99.4	101	1.26	70.0-130	25
1,1-Dichloroethane	74644-03	<0.50	39.4	39.9	39.9	40.5	ug/L	EPA 8260B	9/28/10	101	101	0.193	76.5-120	25
1,1-Dichloroethene	74644-03	<0.50	39.4	39.9	41.8	42.2	ug/L	EPA 8260B	9/28/10	106	106	0.296	69.6-124	25

QC Report : Matrix Spike/ Matrix Spike Duplicate

Project Name : **NuStar Vancouver**Project Number : **E3WR-0028**

Parameter	Spiked Sample	Sample Value	Spike Level	Spike Dup. Level	Spiked Sample Value	Duplicate Spiked Sample Value	Units	Analysis Method	Date Analyzed	Spiked Sample Percent Recov.	Duplicate Spiked Sample Percent Recov.	Relative Percent Diff.	Spiked Sample Percent Recov. Limit	Relative Percent Diff. Limit
1,1-Dichloropropene	74644-03	<0.50	39.4	39.9	39.6	40.1	ug/L	EPA 8260B	9/28/10	101	100	0.0635	70.0-130	25
1,2,3-Trichlorobenzene	74644-03	<0.50	39.4	39.9	38.6	39.2	ug/L	EPA 8260B	9/28/10	98.1	98.3	0.206	70.0-130	25
1,2,3-Trichloropropane	74644-03	<0.50	39.4	39.9	38.1	40.1	ug/L	EPA 8260B	9/28/10	96.9	100	3.51	70.0-130	25
1,2,4-Trichlorobenzene	74644-03	<0.50	39.4	39.9	38.9	39.1	ug/L	EPA 8260B	9/28/10	98.8	98.1	0.741	70.0-130	25
1,2,4-Trimethylbenzene	74644-03	<0.50	39.4	39.9	41.8	41.5	ug/L	EPA 8260B	9/28/10	106	104	2.17	70.0-130	25
1,2-Dibromoethane	74644-03	<0.50	39.4	39.9	35.5	37.1	ug/L	EPA 8260B	9/28/10	90.2	92.9	2.89	80-120	25
1,2-Dichlorobenzene	74644-03	<0.50	39.4	39.9	38.2	38.8	ug/L	EPA 8260B	9/28/10	97.0	97.2	0.232	80-120	25
1,2-Dichloroethane	74644-03	<0.50	39.4	39.9	38.6	39.1	ug/L	EPA 8260B	9/28/10	98.0	97.9	0.0252	75.7-122	25
1,2-Dichloropropane	74644-03	<0.50	39.4	39.9	39.8	39.9	ug/L	EPA 8260B	9/28/10	101	99.9	1.12	80-120	25
1,2-dibromo-3-chloropropane	74644-03	<0.50	39.4	39.9	39.8	41.5	ug/L	EPA 8260B	9/28/10	101	104	2.85	70.0-130	25

QC Report : Matrix Spike/ Matrix Spike Duplicate

Project Name : **NuStar Vancouver**Project Number : **E3WR-0028**

Parameter	Spiked Sample	Sample Value	Spike Level	Spike Dup. Level	Spiked Sample Value	Duplicate Spiked Sample Value	Units	Analysis Method	Date Analyzed	Spiked Sample Percent Recov.	Duplicate Spiked Sample Percent Recov.	Relative Percent Diff.	Spiked Sample Percent Recov. Limit	Relative Percent Diff. Limit
1,3,5-Trimethylbenzene	74644-03	<0.50	39.4	39.9	41.9	41.5	ug/L	EPA 8260B	9/28/10	106	104	2.26	70.0-130	25
1,3-Dichlorobenzene	74644-03	<0.50	39.4	39.9	41.2	40.9	ug/L	EPA 8260B	9/28/10	105	102	2.14	79.3-120	25
1,3-Dichloropropane	74644-03	<0.50	39.4	39.9	38.6	39.2	ug/L	EPA 8260B	9/28/10	98.1	98.3	0.201	70.0-130	25
1,4-Dichlorobenzene	74644-03	<0.50	39.4	39.9	37.9	38.6	ug/L	EPA 8260B	9/28/10	96.4	96.6	0.204	80-120	25
2+4-Chlorotoluene	74644-03	<1.0	78.7	79.8	81.2	81.1	ug/L	EPA 8260B	9/28/10	103	102	1.52	70.0-130	25
2,2-Dichloropropane	74644-03	<0.50	39.4	39.9	38.7	39.0	ug/L	EPA 8260B	9/28/10	98.2	97.7	0.495	65.6-145	25
Benzene	74644-03	<0.50	39.4	39.9	39.6	39.9	ug/L	EPA 8260B	9/28/10	100	100	0.570	80-120	25
Bromobenzene	74644-03	<0.50	39.4	39.9	39.8	39.4	ug/L	EPA 8260B	9/28/10	101	98.6	2.40	70.0-130	25
Bromochloromethane	74644-03	<0.50	39.4	39.9	39.2	39.5	ug/L	EPA 8260B	9/28/10	99.6	98.9	0.739	70.0-130	25
Bromodichloromethane	74644-03	<0.50	39.4	39.9	40.2	40.9	ug/L	EPA 8260B	9/28/10	102	102	0.537	70.0-130	25

QC Report : Matrix Spike/ Matrix Spike Duplicate

Project Name : **NuStar Vancouver**Project Number : **E3WR-0028**

Parameter	Spiked Sample	Sample Value	Spike Level	Spike Dup. Level	Spiked Sample Value	Duplicate Spiked Sample Value	Units	Analysis Method	Date Analyzed	Spiked Sample Percent Recov.	Duplicate Spiked Sample Percent Recov.	Relative Percent Diff.	Spiked Sample Percent Recov. Limit	Relative Percent Diff. Limit
Bromoform	74644-03	<0.50	39.4	39.9	44.0	45.0	ug/L	EPA 8260B	9/28/10	112	113	0.867	73.0-142	25
Bromomethane	74644-03	<20	197	200	220	226	ug/L	EPA 8260B	9/28/10	112	113	1.07	33.5-140	25
Carbon Tetrachloride	74644-03	<0.50	39.4	39.9	41.8	42.7	ug/L	EPA 8260B	9/28/10	106	107	0.585	70.0-130	25
Chlorobenzene	74644-03	<0.50	39.4	39.9	40.0	39.8	ug/L	EPA 8260B	9/28/10	102	99.6	1.90	80-120	25
Chloroethane	74644-03	<0.50	39.4	39.9	38.3	37.7	ug/L	EPA 8260B	9/28/10	97.2	94.4	2.96	70.0-130	25
Chloroform	74644-03	<0.50	39.4	39.9	39.5	39.8	ug/L	EPA 8260B	9/28/10	100	99.7	0.629	80.0-120	25
Chloromethane	74644-03	<0.50	39.4	39.9	42.8	42.4	ug/L	EPA 8260B	9/28/10	109	106	2.27	45.9-142	25
Dibromochloromethane	74644-03	<0.50	39.4	39.9	40.8	42.7	ug/L	EPA 8260B	9/28/10	104	107	3.18	70.0-130	25
Dibromomethane	74644-03	<0.50	39.4	39.9	40.7	41.5	ug/L	EPA 8260B	9/28/10	103	104	0.437	70.0-130	25
Dichlorodifluoromethane	74644-03	<0.50	39.4	39.9	39.3	39.2	ug/L	EPA 8260B	9/28/10	99.8	98.3	1.58	47.4-151	25

QC Report : Matrix Spike/ Matrix Spike Duplicate

Project Name : **NuStar Vancouver**Project Number : **E3WR-0028**

Parameter	Spiked Sample	Sample Value	Spike Level	Spike Dup. Level	Spiked Sample Value	Duplicate Spiked Sample Value	Units	Analysis Method	Date Analyzed	Spiked Sample Percent Recov.	Duplicate Spiked Sample Percent Recov.	Relative Percent Diff.	Spiked Sample Percent Recov. Limit	Relative Percent Diff. Limit
Ethylbenzene	74644-03	<0.50	39.4	39.9	41.0	41.0	ug/L	EPA 8260B	9/28/10	104	103	1.36	80-120	25
Hexachlorobutadiene	74644-03	<0.50	39.4	39.9	40.4	41.0	ug/L	EPA 8260B	9/28/10	102	103	0.322	70.0-130	25
Isopropyl benzene	74644-03	<0.50	39.4	39.9	40.8	40.9	ug/L	EPA 8260B	9/28/10	104	102	1.16	70.0-130	25
Methylene Chloride	74644-03	<5.0	39.4	39.9	40.0	40.5	ug/L	EPA 8260B	9/28/10	102	101	0.202	70.0-130	25
Naphthalene	74644-03	0.64	39.4	39.9	39.3	40.8	ug/L	EPA 8260B	9/28/10	98.2	101	2.60	70.0-130	25
O-Xylene	74644-03	<0.50	39.4	39.9	40.9	41.1	ug/L	EPA 8260B	9/28/10	104	103	0.904	79.7-120	25
P + M Xylene	74644-03	<1.0	39.4	39.9	41.2	41.1	ug/L	EPA 8260B	9/28/10	105	103	1.74	76.8-120	25
Styrene	74644-03	<0.50	39.4	39.9	43.1	43.3	ug/L	EPA 8260B	9/28/10	110	108	1.02	70.0-130	25
Tetrachloroethene	74644-03	62	39.4	39.9	97.0	97.2	ug/L	EPA 8260B	9/28/10	89.4	88.7	0.770	77.0-120	25
Toluene	74644-03	<0.50	39.4	39.9	39.8	40.1	ug/L	EPA 8260B	9/28/10	101	100	0.487	80-120	25

QC Report : Matrix Spike/ Matrix Spike Duplicate

Project Name : **NuStar Vancouver**Project Number : **E3WR-0028**

Parameter	Spiked Sample	Sample Value	Spike Level	Spike Dup. Level	Spiked Sample Value	Duplicate Spiked Sample Value	Units	Analysis Method	Date Analyzed	Spiked Sample Percent Recov.	Duplicate Spiked Sample Percent Recov.	Relative Percent Diff.	Spiked Sample Percent Recov. Limit	Relative Percent Diff. Limit
Trichloroethene	74644-03	16	39.4	39.9	55.0	55.5	ug/L	EPA 8260B	9/28/10	98.6	98.4	0.276	80-120	25
Trichlorofluoromethane	74644-03	<0.50	39.4	39.9	38.5	39.0	ug/L	EPA 8260B	9/28/10	97.9	97.6	0.299	70.0-130	25
Vinyl Chloride	74644-03	0.66	39.4	39.9	38.8	40.2	ug/L	EPA 8260B	9/28/10	96.8	98.9	2.21	42.1-138	25
c-1,3-Dichloropropene	74644-03	<5.0	39.4	39.9	39.2	39.6	ug/L	EPA 8260B	9/28/10	99.5	99.1	0.384	70.0-130	25
cis-1,2-Dichloroethene	74644-03	35	39.4	39.9	72.9	73.1	ug/L	EPA 8260B	9/28/10	95.6	94.7	0.865	70.0-130	25
n-butylbenzene	74644-03	<0.50	39.4	39.9	40.6	41.1	ug/L	EPA 8260B	9/28/10	103	103	0.0956	70.0-130	25
n-propylbenzene	74644-03	<0.50	39.4	39.9	42.3	42.0	ug/L	EPA 8260B	9/28/10	108	105	2.07	70.0-130	25
p-isopropyltoluene	74644-03	<0.50	39.4	39.9	42.4	41.9	ug/L	EPA 8260B	9/28/10	108	105	2.54	70.0-130	25
sec-butylbenzene	74644-03	<0.50	39.4	39.9	41.7	41.4	ug/L	EPA 8260B	9/28/10	106	104	2.23	70.0-130	25
t-1,2-Dichloroethene	74644-03	<5.0	39.4	39.9	40.8	41.3	ug/L	EPA 8260B	9/28/10	104	103	0.154	70.0-130	25

QC Report : Matrix Spike/ Matrix Spike Duplicate

Project Name : **NuStar Vancouver**Project Number : **E3WR-0028**

Parameter	Spiked Sample	Sample Value	Spike Level	Spike Dup. Level	Spiked Sample Value	Duplicate Spiked Sample Value	Units	Analysis Method	Date Analyzed	Spiked Sample Percent Recov.	Duplicate Spiked Sample Percent Recov.	Relative Percent Diff.	Spiked Sample Percent Recov. Limit	Relative Percent Diff. Limit
t-1,3-Dichloropropene														
	74644-03	<5.0	39.4	39.9	39.2	40.2	ug/L	EPA 8260B	9/28/10	99.6	101	1.15	70.0-130	25
tert-butylbenzene														
	74644-03	<0.50	39.4	39.9	41.2	40.8	ug/L	EPA 8260B	9/28/10	105	102	2.22	70.0-130	25
Chloride														
Nitrite as NO2														
	74567-01	46	2.50	2.50	48.7	48.1	mg/L	EPA 300.0	9/22/10	90.7	65.6	1.30	85.0-115	10
Nitrate as NO3														
	74567-01	< 0.50	1.64	1.64	1.52	1.45	mg/L	EPA 300.0	9/22/10	92.6	88.3	4.76	85.0-115	10
	74567-01	< 0.50	2.21	2.21	2.06	2.06	mg/L	EPA 300.0	9/22/10	93.0	93.0	0.0922	85.0-115	10
Sulfate														
	74663-04	20	2.50	2.50	22.2	22.3	mg/L	EPA 300.0	9/24/10	96.5	100	0.447	85.0-115	10
1,1,1,2-Tetrachloroethane														
	74640-15	<0.50	40.0	40.0	41.2	40.4	ug/L	EPA 8260B	9/23/10	103	101	2.00	70.0-130	25
1,1,1-Trichloroethane														
	74640-15	<0.50	40.0	40.0	39.3	38.8	ug/L	EPA 8260B	9/23/10	98.3	96.9	1.46	70.0-130	25
1,1,2-Trichloroethane														
	74640-15	<0.50	40.0	40.0	39.0	38.4	ug/L	EPA 8260B	9/23/10	97.4	96.1	1.39	70.0-130	25

QC Report : Matrix Spike/ Matrix Spike Duplicate

Project Name : **NuStar Vancouver**Project Number : **E3WR-0028**

Parameter	Spiked Sample	Sample Value	Spike Level	Spike Dup. Level	Spiked Sample Value	Duplicate Spiked Sample Value	Units	Analysis Method	Date Analyzed	Spiked Sample Percent Recov.	Duplicate Spiked Sample Percent Recov.	Relative Percent Diff.	Spiked Sample Percent Recov. Limit	Relative Percent Diff. Limit
1,1-Dichloroethane	74640-15	<0.50	40.0	40.0	41.7	41.2	ug/L	EPA 8260B	9/23/10	104	103	1.32	76.5-120	25
1,1-Dichloroethene	74640-15	<0.50	40.0	40.0	45.1	44.0	ug/L	EPA 8260B	9/23/10	113	110	2.40	69.6-124	25
1,1-Dichloropropene	74640-15	<0.50	40.0	40.0	39.0	37.9	ug/L	EPA 8260B	9/23/10	97.6	94.8	2.86	70.0-130	25
1,2,3-Trichlorobenzene	74640-15	<0.50	40.0	40.0	38.0	37.0	ug/L	EPA 8260B	9/23/10	95.1	92.4	2.86	70.0-130	25
1,2,3-Trichloropropane	74640-15	<0.50	40.0	40.0	40.4	39.6	ug/L	EPA 8260B	9/23/10	101	98.9	2.13	70.0-130	25
1,2,4-Trichlorobenzene	74640-15	<0.50	40.0	40.0	38.2	37.9	ug/L	EPA 8260B	9/23/10	95.5	94.7	0.821	70.0-130	25
1,2,4-Trimethylbenzene	74640-15	<0.50	40.0	40.0	42.1	40.3	ug/L	EPA 8260B	9/23/10	105	101	4.37	70.0-130	25
1,2-Dibromoethane	74640-15	<0.50	40.0	40.0	34.4	34.2	ug/L	EPA 8260B	9/23/10	86.0	85.6	0.502	80-120	25
1,2-Dichlorobenzene	74640-15	<0.50	40.0	40.0	38.7	38.6	ug/L	EPA 8260B	9/23/10	96.7	96.6	0.0836	80-120	25
1,2-Dichloroethane	74640-15	<0.50	40.0	40.0	37.1	36.2	ug/L	EPA 8260B	9/23/10	92.8	90.5	2.46	75.7-122	25

QC Report : Matrix Spike/ Matrix Spike Duplicate

Project Name : **NuStar Vancouver**Project Number : **E3WR-0028**

Parameter	Spiked Sample	Sample Value	Spike Level	Spike Dup. Level	Spiked Sample Value	Duplicate Spiked Sample Value	Units	Analysis Method	Date Analyzed	Spiked Sample Percent Recov.	Duplicate Spiked Sample Percent Recov.	Relative Percent Diff.	Spiked Sample Percent Recov. Limit	Relative Percent Diff. Limit
1,2-Dichloropropane	74640-15	<0.50	40.0	40.0	38.1	37.8	ug/L	EPA 8260B	9/23/10	95.3	94.5	0.805	80-120	25
1,2-dibromo-3-chloropropane	74640-15	<0.50	40.0	40.0	41.0	42.2	ug/L	EPA 8260B	9/23/10	103	105	2.66	70.0-130	25
1,3,5-Trimethylbenzene	74640-15	<0.50	40.0	40.0	41.7	40.0	ug/L	EPA 8260B	9/23/10	104	100	3.97	70.0-130	25
1,3-Dichlorobenzene	74640-15	<0.50	40.0	40.0	40.4	38.9	ug/L	EPA 8260B	9/23/10	101	97.2	3.78	79.3-120	25
1,3-Dichloropropane	74640-15	<0.50	40.0	40.0	38.0	37.5	ug/L	EPA 8260B	9/23/10	95.0	93.9	1.17	70.0-130	25
1,4-Dichlorobenzene	74640-15	<0.50	40.0	40.0	38.5	38.2	ug/L	EPA 8260B	9/23/10	96.3	95.6	0.719	80-120	25
2+4-Chlorotoluene	74640-15	<1.0	80.0	80.0	81.9	78.9	ug/L	EPA 8260B	9/23/10	102	98.6	3.71	70.0-130	25
2,2-Dichloropropane	74640-15	<0.50	40.0	40.0	40.3	39.6	ug/L	EPA 8260B	9/23/10	101	99.0	1.76	65.6-145	25
Benzene	74640-15	<0.50	40.0	40.0	38.9	38.2	ug/L	EPA 8260B	9/23/10	97.3	95.4	1.95	80-120	25
Bromobenzene	74640-15	<0.50	40.0	40.0	40.1	39.4	ug/L	EPA 8260B	9/23/10	100	98.5	1.73	70.0-130	25

QC Report : Matrix Spike/ Matrix Spike Duplicate

Project Name : **NuStar Vancouver**Project Number : **E3WR-0028**

Parameter	Spiked Sample	Sample Value	Spike Level	Spike Dup. Level	Spiked Sample Value	Duplicate Spiked Sample Value	Units	Analysis Method	Date Analyzed	Spiked Sample Percent Recov.	Duplicate Spiked Sample Percent Recov.	Relative Percent Diff.	Spiked Sample Percent Recov. Limit	Relative Percent Diff. Limit
Bromochloromethane	74640-15	<0.50	40.0	40.0	39.8	39.7	ug/L	EPA 8260B	9/23/10	99.6	99.2	0.455	70.0-130	25
Bromodichloromethane	74640-15	<0.50	40.0	40.0	39.5	39.0	ug/L	EPA 8260B	9/23/10	98.7	97.6	1.09	70.0-130	25
Bromoform	74640-15	<0.50	40.0	40.0	45.0	44.4	ug/L	EPA 8260B	9/23/10	112	111	1.20	73.0-142	25
Bromomethane	74640-15	<20	200	200	201	226	ug/L	EPA 8260B	9/23/10	100	113	12.0	33.5-140	25
Carbon Tetrachloride	74640-15	<0.50	40.0	40.0	38.4	38.4	ug/L	EPA 8260B	9/23/10	96.0	96.0	0.0165	70.0-130	25
Chlorobenzene	74640-15	<0.50	40.0	40.0	38.9	38.1	ug/L	EPA 8260B	9/23/10	97.3	95.3	2.10	80-120	25
Chloroethane	74640-15	<0.50	40.0	40.0	45.2	44.5	ug/L	EPA 8260B	9/23/10	113	111	1.57	70.0-130	25
Chloroform	74640-15	<0.50	40.0	40.0	40.1	39.4	ug/L	EPA 8260B	9/23/10	100	98.6	1.79	80.0-120	25
Chloromethane	74640-15	<0.50	40.0	40.0	43.1	43.1	ug/L	EPA 8260B	9/23/10	108	108	0.00913	45.9-142	25
Dibromochloromethane	74640-15	<0.50	40.0	40.0	41.1	41.0	ug/L	EPA 8260B	9/23/10	103	102	0.251	70.0-130	25

QC Report : Matrix Spike/ Matrix Spike Duplicate

Project Name : **NuStar Vancouver**Project Number : **E3WR-0028**

Parameter	Spiked Sample	Sample Value	Spike Level	Spike Dup. Level	Spiked Sample Value	Duplicate Spiked Sample Value	Units	Analysis Method	Date Analyzed	Spiked Sample Percent Recov.	Duplicate Spiked Sample Percent Recov.	Relative Percent Diff.	Spiked Sample Percent Recov. Limit	Relative Percent Diff. Limit
Dibromomethane	74640-15	<0.50	40.0	40.0	40.2	39.1	ug/L	EPA 8260B	9/23/10	100	97.7	2.86	70.0-130	25
Dichlorodifluoromethane	74640-15	<0.50	40.0	40.0	44.4	43.5	ug/L	EPA 8260B	9/23/10	111	109	1.89	47.4-151	25
Ethylbenzene	74640-15	2.8	40.0	40.0	43.2	42.1	ug/L	EPA 8260B	9/23/10	101	98.4	2.75	80-120	25
Hexachlorobutadiene	74640-15	<0.50	40.0	40.0	36.9	36.6	ug/L	EPA 8260B	9/23/10	92.3	91.5	0.890	70.0-130	25
Isopropyl benzene	74640-15	<0.50	40.0	40.0	41.6	40.2	ug/L	EPA 8260B	9/23/10	104	100	3.58	70.0-130	25
Methylene Chloride	74640-15	<5.0	40.0	40.0	42.6	42.4	ug/L	EPA 8260B	9/23/10	106	106	0.599	70.0-130	25
Naphthalene	74640-15	1.2	40.0	40.0	42.3	42.5	ug/L	EPA 8260B	9/23/10	103	103	0.579	70.0-130	25
O-Xylene	74640-15	<0.50	40.0	40.0	42.1	40.8	ug/L	EPA 8260B	9/23/10	105	102	3.02	79.7-120	25
P + M Xylene	74640-15	1.2	40.0	40.0	40.6	39.0	ug/L	EPA 8260B	9/23/10	98.6	94.5	4.30	76.8-120	25
Styrene	74640-15	<0.50	40.0	40.0	43.9	42.6	ug/L	EPA 8260B	9/23/10	110	106	2.94	70.0-130	25

QC Report : Matrix Spike/ Matrix Spike Duplicate

Project Name : **NuStar Vancouver**Project Number : **E3WR-0028**

Parameter	Spiked Sample	Sample Value	Spike Level	Spike Dup. Level	Spiked Sample Value	Duplicate Spiked Sample Value	Units	Analysis Method	Date Analyzed	Spiked Sample Percent Recov.	Duplicate Spiked Sample Percent Recov.	Relative Percent Diff.	Spiked Sample Percent Recov. Limit	Relative Percent Diff. Limit
Tetrachloroethene	74640-15	<0.50	40.0	40.0	38.1	36.9	ug/L	EPA 8260B	9/23/10	95.3	92.2	3.32	77.0-120	25
Toluene	74640-15	0.94	40.0	40.0	38.6	38.0	ug/L	EPA 8260B	9/23/10	94.1	92.6	1.54	80-120	25
Trichloroethene	74640-15	<0.50	40.0	40.0	38.3	38.0	ug/L	EPA 8260B	9/23/10	95.9	95.1	0.785	80-120	25
Trichlorofluoromethane	74640-15	<0.50	40.0	40.0	47.4	46.8	ug/L	EPA 8260B	9/23/10	118	117	1.40	70.0-130	25
Vinyl Chloride	74640-15	<0.50	40.0	40.0	41.8	41.7	ug/L	EPA 8260B	9/23/10	104	104	0.123	42.1-138	25
c-1,3-Dichloropropene	74640-15	<5.0	40.0	40.0	37.3	37.7	ug/L	EPA 8260B	9/23/10	93.4	94.4	1.05	70.0-130	25
cis-1,2-Dichloroethene	74640-15	<0.50	40.0	40.0	41.3	40.7	ug/L	EPA 8260B	9/23/10	103	102	1.49	70.0-130	25
n-butylbenzene	74640-15	<0.50	40.0	40.0	39.8	39.1	ug/L	EPA 8260B	9/23/10	99.6	97.7	1.94	70.0-130	25
n-propylbenzene	74640-15	1.2	40.0	40.0	42.4	41.0	ug/L	EPA 8260B	9/23/10	103	99.5	3.56	70.0-130	25
p-isopropyltoluene	74640-15	<0.50	40.0	40.0	42.6	41.0	ug/L	EPA 8260B	9/23/10	106	102	3.94	70.0-130	25

QC Report : Matrix Spike/ Matrix Spike Duplicate

Project Name : **NuStar Vancouver**Project Number : **E3WR-0028**

Parameter	Spiked Sample	Sample Value	Spike Level	Spike Dup. Level	Spiked Sample Value	Duplicate Spiked Sample Value	Units	Analysis Method	Date Analyzed	Spiked Sample Percent Recov.	Duplicate Spiked Sample Percent Recov.	Relative Percent Diff.	Spiked Sample Percent Recov. Limit	Relative Percent Diff. Limit
sec-butylbenzene	74640-15	<0.50	40.0	40.0	41.7	40.3	ug/L	EPA 8260B	9/23/10	104	101	3.39	70.0-130	25
t-1,2-Dichloroethene	74640-15	<5.0	40.0	40.0	43.4	43.4	ug/L	EPA 8260B	9/23/10	108	108	0.157	70.0-130	25
t-1,3-Dichloropropene	74640-15	<5.0	40.0	40.0	38.1	38.5	ug/L	EPA 8260B	9/23/10	95.2	96.2	0.987	70.0-130	25
tert-butylbenzene	74640-15	<0.50	40.0	40.0	41.0	39.8	ug/L	EPA 8260B	9/23/10	102	99.5	3.03	70.0-130	25

QC Report : Laboratory Control Sample (LCS)

Project Name : **NuStar Vancouver**Project Number : **E3WR-0028**

Parameter	Spike Level	Units	Analysis Method	Date Analyzed	LCS Percent Recov.	LCS Percent Recov. Limit
Iron	0.400	mg/L	EPA 6010B	9/29/10	102	85-115
Manganese	0.400	mg/L	EPA 6010B	9/29/10	104	85-115
Potassium	4.00	mg/L	EPA 6010B	9/29/10	106	85-115
1,1,1,2-Tetrachloroethane	40.0	ug/L	EPA 8260B	9/28/10	106	70.0-130
1,1,1-Trichloroethane	40.0	ug/L	EPA 8260B	9/28/10	101	70.0-130
1,1,2,2-Tetrachloroethane	40.0	ug/L	EPA 8260B	9/28/10	109	80-121
1,1,2-Trichloroethane	40.0	ug/L	EPA 8260B	9/28/10	102	70.0-130
1,1-Dichloroethane	40.0	ug/L	EPA 8260B	9/28/10	99.4	76.5-120
1,1-Dichloroethene	40.0	ug/L	EPA 8260B	9/28/10	103	69.6-124
1,1-Dichloropropene	40.0	ug/L	EPA 8260B	9/28/10	100	70.0-130
1,2,3-Trichlorobenzene	40.0	ug/L	EPA 8260B	9/28/10	102	70.0-130
1,2,3-Trichloropropane	40.0	ug/L	EPA 8260B	9/28/10	112	70.0-130
1,2,4-Trichlorobenzene	40.0	ug/L	EPA 8260B	9/28/10	100	70.0-130
1,2,4-Trimethylbenzene	40.0	ug/L	EPA 8260B	9/28/10	104	70.0-130
1,2-Dibromoethane	40.0	ug/L	EPA 8260B	9/28/10	94.9	80-120
1,2-Dichlorobenzene	40.0	ug/L	EPA 8260B	9/28/10	97.6	80-120
1,2-Dichloroethane	40.0	ug/L	EPA 8260B	9/28/10	98.5	75.7-122
1,2-Dichloropropane	40.0	ug/L	EPA 8260B	9/28/10	98.5	80-120
1,2-dibromo-3-chloropropane	40.0	ug/L	EPA 8260B	9/28/10	125	70.0-130
1,3,5-Trimethylbenzene	40.0	ug/L	EPA 8260B	9/28/10	104	70.0-130
1,3-Dichlorobenzene	40.0	ug/L	EPA 8260B	9/28/10	102	79.3-120
1,3-Dichloropropane	40.0	ug/L	EPA 8260B	9/28/10	100	70.0-130

QC Report : Laboratory Control Sample (LCS)Project Name : **NuStar Vancouver**Project Number : **E3WR-0028**

Parameter	Spike Level	Units	Analysis Method	Date Analyzed	LCS Percent Recov.	LCS Percent Recov. Limit
1,4-Dichlorobenzene	40.0	ug/L	EPA 8260B	9/28/10	96.6	80-120
2+4-Chlorotoluene	80.0	ug/L	EPA 8260B	9/28/10	102	70.0-130
2,2-Dichloropropane	40.0	ug/L	EPA 8260B	9/28/10	96.6	65.6-145
Benzene	40.0	ug/L	EPA 8260B	9/28/10	98.8	80-120
Bromobenzene	40.0	ug/L	EPA 8260B	9/28/10	99.4	70.0-130
Bromochloromethane	40.0	ug/L	EPA 8260B	9/28/10	99.9	70.0-130
Bromodichloromethane	40.0	ug/L	EPA 8260B	9/28/10	100	70.0-130
Bromoform	40.0	ug/L	EPA 8260B	9/28/10	118	73.0-142
Bromomethane	200	ug/L	EPA 8260B	9/28/10	87.4	33.5-140
Carbon Tetrachloride	40.0	ug/L	EPA 8260B	9/28/10	103	70.0-130
Chlorobenzene	40.0	ug/L	EPA 8260B	9/28/10	99.7	80-120
Chloroethane	40.0	ug/L	EPA 8260B	9/28/10	94.2	70.0-130
Chloroform	40.0	ug/L	EPA 8260B	9/28/10	98.3	80.0-120
Chloromethane	40.0	ug/L	EPA 8260B	9/28/10	110	45.9-142
Dibromochloromethane	40.0	ug/L	EPA 8260B	9/28/10	104	70.0-130
Dibromomethane	40.0	ug/L	EPA 8260B	9/28/10	106	70.0-130
Dichlorodifluoromethane	40.0	ug/L	EPA 8260B	9/28/10	89.4	47.4-151
Ethylbenzene	40.0	ug/L	EPA 8260B	9/28/10	102	80-120
Hexachlorobutadiene	40.0	ug/L	EPA 8260B	9/28/10	103	70.0-130
Isopropyl benzene	40.0	ug/L	EPA 8260B	9/28/10	103	70.0-130
Methylene Chloride	40.0	ug/L	EPA 8260B	9/28/10	100	70.0-130
Naphthalene	40.0	ug/L	EPA 8260B	9/28/10	112	70.0-130
O-Xylene	40.0	ug/L	EPA 8260B	9/28/10	102	79.7-120

QC Report : Laboratory Control Sample (LCS)

Project Name : **NuStar Vancouver**Project Number : **E3WR-0028**

Parameter	Spike Level	Units	Analysis Method	Date Analyzed	LCS Percent Recov.	LCS Percent Recov. Limit
P + M Xylene	40.0	ug/L	EPA 8260B	9/28/10	102	76.8-120
Styrene	40.0	ug/L	EPA 8260B	9/28/10	108	70.0-130
Tetrachloroethene	40.0	ug/L	EPA 8260B	9/28/10	104	77.0-120
Toluene	40.0	ug/L	EPA 8260B	9/28/10	99.5	80-120
Trichloroethene	40.0	ug/L	EPA 8260B	9/28/10	106	80-120
Trichlorofluoromethane	40.0	ug/L	EPA 8260B	9/28/10	95.0	70.0-130
Vinyl Chloride	40.0	ug/L	EPA 8260B	9/28/10	96.3	42.1-138
c-1,3-Dichloropropene	40.0	ug/L	EPA 8260B	9/28/10	98.0	70.0-130
cis-1,2-Dichloroethene	40.0	ug/L	EPA 8260B	9/28/10	100	70.0-130
n-butylbenzene	40.0	ug/L	EPA 8260B	9/28/10	103	70.0-130
n-propylbenzene	40.0	ug/L	EPA 8260B	9/28/10	105	70.0-130
p-isopropyltoluene	40.0	ug/L	EPA 8260B	9/28/10	106	70.0-130
sec-butylbenzene	40.0	ug/L	EPA 8260B	9/28/10	104	70.0-130
t-1,2-Dichloroethene	40.0	ug/L	EPA 8260B	9/28/10	102	70.0-130
t-1,3-Dichloropropene	40.0	ug/L	EPA 8260B	9/28/10	99.5	70.0-130
tert-butylbenzene	40.0	ug/L	EPA 8260B	9/28/10	102	70.0-130
1,1,1,2-Tetrachloroethane	40.0	ug/L	EPA 8260B	9/23/10	102	70.0-130
1,1,1-Trichloroethane	40.0	ug/L	EPA 8260B	9/23/10	96.2	70.0-130
1,1,2-Trichloroethane	40.0	ug/L	EPA 8260B	9/23/10	93.1	70.0-130
1,1-Dichloroethane	40.0	ug/L	EPA 8260B	9/23/10	104	76.5-120
1,1-Dichloroethene	40.0	ug/L	EPA 8260B	9/23/10	112	69.6-124
1,1-Dichloropropene	40.0	ug/L	EPA 8260B	9/23/10	95.2	70.0-130

QC Report : Laboratory Control Sample (LCS)

Project Name : **NuStar Vancouver**Project Number : **E3WR-0028**

Parameter	Spike Level	Units	Analysis Method	Date Analyzed	LCS Percent Recov.	LCS Percent Recov. Limit
1,2,3-Trichlorobenzene	40.0	ug/L	EPA 8260B	9/23/10	96.8	70.0-130
1,2,3-Trichloropropane	40.0	ug/L	EPA 8260B	9/23/10	97.3	70.0-130
1,2,4-Trichlorobenzene	40.0	ug/L	EPA 8260B	9/23/10	97.7	70.0-130
1,2,4-Trimethylbenzene	40.0	ug/L	EPA 8260B	9/23/10	107	70.0-130
1,2-Dibromoethane	40.0	ug/L	EPA 8260B	9/23/10	84.3	80-120
1,2-Dichlorobenzene	40.0	ug/L	EPA 8260B	9/23/10	96.1	80-120
1,2-Dichloroethane	40.0	ug/L	EPA 8260B	9/23/10	89.2	75.7-122
1,2-Dichloropropane	40.0	ug/L	EPA 8260B	9/23/10	92.9	80-120
1,2-dibromo-3-chloropropane	40.0	ug/L	EPA 8260B	9/23/10	99.5	70.0-130
1,3,5-Trimethylbenzene	40.0	ug/L	EPA 8260B	9/23/10	107	70.0-130
1,3-Dichlorobenzene	40.0	ug/L	EPA 8260B	9/23/10	101	79.3-120
1,3-Dichloropropane	40.0	ug/L	EPA 8260B	9/23/10	92.4	70.0-130
1,4-Dichlorobenzene	40.0	ug/L	EPA 8260B	9/23/10	95.8	80-120
2+4-Chlorotoluene	80.0	ug/L	EPA 8260B	9/23/10	101	70.0-130
2,2-Dichloropropane	40.0	ug/L	EPA 8260B	9/23/10	100	65.6-145
Benzene	40.0	ug/L	EPA 8260B	9/23/10	96.2	80-120
Bromobenzene	40.0	ug/L	EPA 8260B	9/23/10	100	70.0-130
Bromochloromethane	40.0	ug/L	EPA 8260B	9/23/10	99.9	70.0-130
Bromodichloromethane	40.0	ug/L	EPA 8260B	9/23/10	96.9	70.0-130
Bromoform	40.0	ug/L	EPA 8260B	9/23/10	109	73.0-142
Bromomethane	200	ug/L	EPA 8260B	9/23/10	112	33.5-140
Carbon Tetrachloride	40.0	ug/L	EPA 8260B	9/23/10	94.7	70.0-130
Chlorobenzene	40.0	ug/L	EPA 8260B	9/23/10	96.3	80-120

QC Report : Laboratory Control Sample (LCS)

Project Name : **NuStar Vancouver**Project Number : **E3WR-0028**

Parameter	Spike Level	Units	Analysis Method	Date Analyzed	LCS Percent Recov.	LCS Percent Recov. Limit
Chloroethane	40.0	ug/L	EPA 8260B	9/23/10	115	70.0-130
Chloroform	40.0	ug/L	EPA 8260B	9/23/10	98.2	80.0-120
Chloromethane	40.0	ug/L	EPA 8260B	9/23/10	110	45.9-142
Dibromochloromethane	40.0	ug/L	EPA 8260B	9/23/10	101	70.0-130
Dibromomethane	40.0	ug/L	EPA 8260B	9/23/10	98.4	70.0-130
Dichlorodifluoromethane	40.0	ug/L	EPA 8260B	9/23/10	113	47.4-151
Ethylbenzene	40.0	ug/L	EPA 8260B	9/23/10	103	80-120
Hexachlorobutadiene	40.0	ug/L	EPA 8260B	9/23/10	97.0	70.0-130
Isopropyl benzene	40.0	ug/L	EPA 8260B	9/23/10	102	70.0-130
Methylene Chloride	40.0	ug/L	EPA 8260B	9/23/10	105	70.0-130
Naphthalene	40.0	ug/L	EPA 8260B	9/23/10	104	70.0-130
O-Xylene	40.0	ug/L	EPA 8260B	9/23/10	107	79.7-120
P + M Xylene	40.0	ug/L	EPA 8260B	9/23/10	104	76.8-120
Styrene	40.0	ug/L	EPA 8260B	9/23/10	109	70.0-130
Tetrachloroethene	40.0	ug/L	EPA 8260B	9/23/10	93.1	77.0-120
Toluene	40.0	ug/L	EPA 8260B	9/23/10	96.8	80-120
Trichloroethene	40.0	ug/L	EPA 8260B	9/23/10	95.5	80-120
Trichlorofluoromethane	40.0	ug/L	EPA 8260B	9/23/10	119	70.0-130
Vinyl Chloride	40.0	ug/L	EPA 8260B	9/23/10	110	42.1-138
c-1,3-Dichloropropene	40.0	ug/L	EPA 8260B	9/23/10	93.3	70.0-130
cis-1,2-Dichloroethene	40.0	ug/L	EPA 8260B	9/23/10	102	70.0-130
n-butylbenzene	40.0	ug/L	EPA 8260B	9/23/10	100	70.0-130
n-propylbenzene	40.0	ug/L	EPA 8260B	9/23/10	104	70.0-130

QC Report : Laboratory Control Sample (LCS)Project Name : **NuStar Vancouver**Project Number : **E3WR-0028**

Parameter	Spike Level	Units	Analysis Method	Date Analyzed	LCS Percent Recov.	LCS Percent Recov. Limit
p-isopropyltoluene	40.0	ug/L	EPA 8260B	9/23/10	106	70.0-130
sec-butylbenzene	40.0	ug/L	EPA 8260B	9/23/10	104	70.0-130
t-1,2-Dichloroethene	40.0	ug/L	EPA 8260B	9/23/10	109	70.0-130
t-1,3-Dichloropropene	40.0	ug/L	EPA 8260B	9/23/10	93.8	70.0-130
tert-butylbenzene	40.0	ug/L	EPA 8260B	9/23/10	104	70.0-130
Chloride	2.50	mg/L	EPA 300.0	9/22/10	97.6	85.0-115
Nitrite as NO2	1.64	mg/L	EPA 300.0	9/22/10	94.6	85.0-115
Nitrate as NO3	2.21	mg/L	EPA 300.0	9/22/10	92.6	85.0-115
Sulfate	2.50	mg/L	EPA 300.0	9/24/10	93.4	85.0-115



2795 2nd Street, Suite 300
 Davis, CA 95618
 Lab: 530.297.4800
 Fax: 530.297.4802

SRG # / Lab No. 74644

Page 2 of 3

Project Contact (Hardcopy or PDF To): STEPHANIE BOSZE
 Company / Address: ASH CREEK ASSOCIATES
 Phone Number: 503 927 4704
 Fax Number:
 Project #: 1126-09 P.O. #:
 Project Name: NUSLAR Vancouver - Co-located Burings
 California EDF Report? Yes No
 Sampling Company Log Code:
 Global ID:
 EDF Deliverable To (Email Address): sbosze@ashcreek.com
 Bill to: NUSLAR
 Sampler Print Name: ADAM REESE
 Sampler Signature: [Signature]

Chain-of-Custody Record and Analysis Request

Project Address:	Sampling		Container				Preservative			Matrix			Analysis Request											TAT										
	Sample Designation	Date	Time	40 ml VOA	Sleeve	Poly	Glass	Tedlar	HCl	HNO ₃	None	Water	Soil	Air	MTBE @ 0.5 ppb (EPA 8260B)	BTEX (EPA 8260B)	TPH Gas (EPA 8260B)	5 Oxygenates (MTBE, DIPE, ETBE, TAME, TBA) (EPA 8260B)	7 Oxygenates (5 oxy + EtOH, MeOH) (EPA 8260B)	Lead Scav. (1,2 DCA & 1,2 EDB) (EPA 8260B)	Volatile Halocarbons (EPA 8260B)	Volatile Organics Full List (EPA 8260B)	Volatile Organics (EPA 524.2 Drinking Water)	TPH as Diesel (EPA 8015M)	TPH as Motor Oil (EPA 8015M)	CAM 17 Metals (EPA 200.7 / 6010)	5 Waste Oil Metals (Cd, Cr, Ni, Pb, Zn) (EPA 200.7 / 6010)	Mercury (EPA 245.1 / 7470 / 7471)	Total Lead (EPA 200.7 / 6010)	W.E.T. Lead (STLC)	<input type="checkbox"/> 12 hr <input type="checkbox"/> 24 hr <input type="checkbox"/> 48 hr <input type="checkbox"/> 72 hr <input type="checkbox"/> 1 wk			
CB-2 (42)	9/21/10	0830	3									X																						11
CB-2 (45)	9/21/10	0900	3									X																						12 04
CB-2 (45) DUP	9/21/10	0900	3									X																						13 05
CB-4 (18)	9/21/10	1030	3									X																						14
CB-4 (25)	9/21/10	1045	3									X																						15
CB-4 (35)	9/21/10	1100	3									X																						16 06
CB-4 (38.5)	9/21/10	1300	4									X																						17
CB-4 (45)	9/21/10	1345	3									X																						18 07
Field Blank	9/20/10	1400	1									X																						19 09
Field Blank #2	9/21/10	0730	1									X																						20 08

Relinquished by: [Signature] Date: 9/21/10 Time: 1700
 Relinquished by: _____ Date: _____ Time: _____ Received by: _____
 Relinquished by: _____ Date: _____ Time: _____ Received by Laboratory: [Signature]

Remarks:
 For CB-2 (45) groundwater sample.
 9 vials include duplicate and MS/MSD samples.

SAMPLE RECEIPT CHECKLIST

RECEIVER

KT
Initials

SRG#: 74644 Date: 092210
 Project ID: MUSTA Vancouver
 Method of Receipt: Courier Over-the-counter Shipper

COC Inspection

Is COC present? Yes No
 Custody seals on shipping container? Intact Broken Not present N/A
 Is COC Signed by Relinquisher? Yes No Dated? Yes No
 Is sampler name legibly indicated on COC? Yes No
 Is analysis or hold requested for all samples? Yes No
 Is the turnaround time indicated on COC? Yes No
 Is COC free of whiteout and uninitialed cross-outs? Yes No, Whiteout No, Cross-outs

Sample Inspection

Coolant Present: Yes No (includes water)
 Temperature °C 2.4 Therm. ID# IRS Initial KT Date/Time 092210 1040 N/A
 Are there custody seals on sample containers? Intact Broken Not present
 Do containers match COC? Yes No No, COC lists absent sample(s) No, Extra sample(s) present
 Are there samples matrices other than soil, water, air or carbon? Yes No
 Are any sample containers broken, leaking or damaged? Yes No
 Are preservatives indicated? Yes, on sample containers Yes, on COC Not indicated N/A
 Are preservatives correct for analyses requested? Yes No N/A
 Are samples within holding time for analyses requested? Yes No
 Are the correct sample containers used for the analyses requested? Yes No
 Is there sufficient sample to perform testing? Yes No
 Does any sample contain product, have strong odor or are otherwise suspected to be hot? Yes No

Receipt Details

Matrix <u>H₂O</u>	Container type <u>Volt</u>	# of containers received <u>36</u>
Matrix <u>H₂O</u>	Container type <u>Poly</u>	# of containers received <u>6</u>
Matrix <u>H₂O</u>	Container type <u>Acidic</u>	# of containers received <u>2</u>

Date and Time Sample Put into Temp Storage Date: 092210 Time: 1040

Quicklog

Are the Sample ID's indicated: On COC On sample container(s) On Both Not indicated
 If Sample ID's are listed on both COC and containers, do they all match? Yes No N/A
 Is the Project ID indicated: On COC On sample container(s) On Both Not indicated
 If project ID is listed on both COC and containers, do they all match? Yes No N/A
 Are the sample collection dates indicated: On COC On sample container(s) On Both Not indicated
 If collection dates are listed on both COC and containers, do they all match? Yes No N/A
 Are the sample collection times indicated: On COC On sample container(s) On Both Not indicated
 If collection times are listed on both COC and containers, do they all match? Yes No N/A

COMMENTS:



Subcontract Laboratory Report Attachments

CALIFORNIA LABORATORY SERVICES

3249 Fitzgerald Road Rancho Cordova, CA 95742

September 30, 2010

CLS Work Order #: CTI0939
COC #: 74644

Scott Forbes
KIFF Analytical
2795 Second St. Suite 300
Davis, CA 95616

Project Name: Nustar Vancouver

Enclosed are the results of analyses for samples received by the laboratory on 09/23/10 15:40. Samples were analyzed pursuant to client request utilizing EPA or other ELAP approved methodologies. I certify that the results are in compliance both technically and for completeness.

Analytical results are attached to this letter. Please call if we can provide additional assistance.

Sincerely,

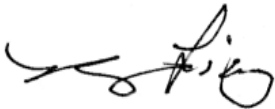

James Liang, Ph.D.
Laboratory Director

CA DOHS ELAP Accreditation/Registration number 1233

CALIFORNIA LABORATORY SERVICES

KIFF Analytical 2795 Second St. Suite 300 Davis, CA 95616	Project: Nustar Vancouver Project Number: 1126-09 Project Manager: Scott Forbes	CLS Work Order #: CTI0939 COC #: 74644
---	---	---

CTI0939

		2795 Second Street, Suite 300 Davis, CA 95618 Lab: 530.297.4800 Fax: 530.297.4808		California Laboratory Services 3249 Fitzgerald Road Rancho Cordova, CA 95742 916-638-7301		COC No. 74644		Page 1 of 1							
		Project Contact (Hardcopy or PDF to): Scott Forbes		EDF Report? YES		Chain-of-Custody Record and Analysis Request									
Company/Address: Kiff Analytical		Recommended but not mandatory to complete this section:		Analysis Request						TAT					
Phone No.: 530-297-4800 FAX No.: 530-297-4808		Global ID:													
Project Number: 1126-09 P.O. No.: 74644		Deliverables to (Email Address): inbox@kiffanalytical.com													
Project Name: Nustar Vancouver		Container / Preservative		Matrix											
Project Address:		250ml Poly Name		Water										Carbon Dioxide	
Sample Designation		Sampling													
		Date	Time												
CB-3 (35)		09/21/10	15:45	1										X	
Relinquished by: <i>[Signature]</i> KIFF Analytical		Date	Time	Received by:		Remarks: 1-10 Bill to: Accounts Payable									
Relinquished by:		Date	Time	Received by:											
Relinquished by:		Date	Time	Received by Laboratory: sonR 9-23-10 15:40											

CALIFORNIA LABORATORY SERVICES

Page 2 of 4

09/30/10 10:33

KIFF Analytical
2795 Second St. Suite 300
Davis, CA 95616

Project: Nustar Vancouver
Project Number: 1126-09
Project Manager: Scott Forbes

CLS Work Order #: CTI0939
COC #: 74644

Conventional Chemistry Parameters by APHA/EPA Methods

Analyte	Result	Reporting Limit	Units	Dilution	Batch	Prepared	Analyzed	Method	Notes
CB-3 (35) (CTI0939-01) Water Sampled: 09/21/10 15:45 Received: 09/23/10 15:40									
Carbon Dioxide as CO2	38	5.0	mg/L	1	CT07166	09/24/10	09/24/10	SM 4500C	

CA DOHS ELAP Accreditation/Registration Number 1233

3249 Fitzgerald Road Rancho Cordova, CA 95742

www.californialab.com

916-638-7301

Fax: 916-638-4510

CALIFORNIA LABORATORY SERVICES

Page 3 of 4

09/30/10 10:33

KIFF Analytical
2795 Second St. Suite 300
Davis, CA 95616

Project: Nustar Vancouver
Project Number: 1126-09
Project Manager: Scott Forbes

CLS Work Order #: CTI0939
COC #: 74644

Conventional Chemistry Parameters by APHA/EPA Methods - Quality Control

Analyte	Result	Reporting Limit	Units	Spike Level	Source Result	%REC	%REC Limits	RPD	RPD Limit	Notes
---------	--------	--------------------	-------	----------------	------------------	------	----------------	-----	--------------	-------

Batch CT07166 - General Preparation

Blank (CT07166-BLK1)

Prepared & Analyzed: 09/24/10

Carbon Dioxide as CO2	ND	5.0	mg/L							
-----------------------	----	-----	------	--	--	--	--	--	--	--

CALIFORNIA LABORATORY SERVICES

Page 4 of 4

09/30/10 10:33

KIFF Analytical
2795 Second St. Suite 300
Davis, CA 95616

Project: Nustar Vancouver
Project Number: 1126-09
Project Manager: Scott Forbes

CLS Work Order #: CTI0939
COC #: 74644

Notes and Definitions

DET Analyte DETECTED
ND Analyte NOT DETECTED at or above the reporting limit
NR Not Reported
dry Sample results reported on a dry weight basis
RPD Relative Percent Difference

CA DOHS ELAP Accreditation/Registration Number 1233

3249 Fitzgerald Road Rancho Cordova, CA 95742 www.californialab.com 916-638-7301 Fax: 916-638-4510

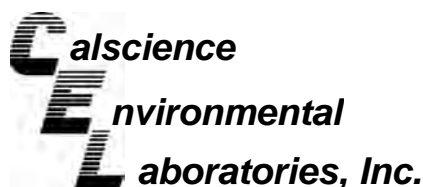

September 29, 2010

Joel Kiff
Kiff Analytical
2795 2nd Street, Suite 300
Davis, CA 95616-6593

Subject: **CalScience Work Order No.: 10-09-1711**
Client Reference: NuStar Vancouver

Dear Client:

Enclosed is an analytical report for the above-referenced project. The samples included in this report were received 9/23/2010 and analyzed in accordance with the attached chain-of-custody.

CalScience Environmental Laboratories certifies that the test results provided in this report meet all NELAC requirements for parameters for which accreditation is required or available. Any exceptions to NELAC requirements are noted in the case narrative. The original report of subcontracted analysis, if any, is provided herein, and follows the standard CalScience data package. The results in this analytical report are limited to the samples tested and any reproduction thereof must be made in its entirety.

If you have any questions regarding this report, please do not hesitate to contact the undersigned.

Sincerely,

A handwritten signature in black ink that reads "Amanda Porter".

CalScience Environmental
Laboratories, Inc.
Amanda Porter
Project Manager

Analytical Report



Kiff Analytical
 2795 2nd Street, Suite 300
 Davis, CA 95616-6593

Date Received: 09/23/10
 Work Order No: 10-09-1711
 Preparation: N/A
 Method: RSK-175M
 Units: ug/L

Project: NuStar Vancouver

Page 1 of 1

Client Sample Number	Lab Sample Number	Date/Time Collected	Matrix	Instrument	Date Prepared	Date/Time Analyzed	QC Batch ID
CB-3 (35)	10-09-1711-1-A	09/21/10 15:45	Aqueous	GC 33	N/A	09/24/10 00:00	100924L01

Parameter	Result	RL	DF	Qual	Parameter	Result	RL	DF	Qual
Ethane	ND	1.00	1		Methane	2100	8.00	8	
Ethylene	ND	1.00	1						

Method Blank	099-12-661-349	N/A	Aqueous	GC 33	N/A	09/24/10 00:00	100924L01
--------------	----------------	-----	---------	-------	-----	-------------------	-----------

Parameter	Result	RL	DF	Qual	Parameter	Result	RL	DF	Qual
Ethane	ND	1.00	1		Methane	ND	1.00	1	
Ethylene	ND	1.00	1						

RL - Reporting Limit , DF - Dilution Factor , Qual - Qualifiers

Analytical Report



Kiff Analytical
2795 2nd Street, Suite 300
Davis, CA 95616-6593

Date Received: 09/23/10
Work Order No: 10-09-1711

Project: NuStar Vancouver

Page 1 of 1

Client Sample Number	Lab Sample Number	Date Collected	Matrix
CB-3 (35)	10-09-1711-1	09/21/10	Aqueous

Parameter	Result	RL	DF	Qual	Units	Date Prepared	Date Analyzed	Method
o-Phosphate (as P)	ND	0.10	1		mg/L	N/A	09/23/10	EPA 300.0
Ammonia (as N)	89	1.0	10		mg/L	09/27/10	09/27/10	SM 4500-NH3 B/C
Carbon, Total Organic	4.8	0.50	1		mg/L	N/A	09/28/10	SM 5310 D

Method Blank				N/A	Aqueous			
---------------------	--	--	--	------------	----------------	--	--	--

Parameter	Result	RL	DF	Qual	Units	Date Prepared	Date Analyzed	Method
o-Phosphate (as P)	ND	0.10	1		mg/L	N/A	09/23/10	EPA 300.0
Ammonia (as N)	ND	0.10	1		mg/L	09/27/10	09/27/10	SM 4500-NH3 B/C
Carbon, Total Organic	ND	0.50	1		mg/L	N/A	09/28/10	SM 5310 D

RL - Reporting Limit , DF - Dilution Factor , Qual - Qualifiers

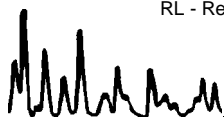

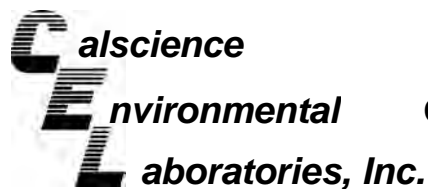

Quality Control - Spike/Spike Duplicate



Kiff Analytical
2795 2nd Street, Suite 300
Davis, CA 95616-6593

Date Received: N/A
Work Order No: 10-09-1711

Project: NuStar Vancouver

Matrix: Aqueous or Solid

<u>Parameter</u>	<u>Method</u>	<u>Quality Control Sample ID</u>	<u>Date Analyzed</u>	<u>Date Extracted</u>	<u>MS% REC</u>	<u>MSD % REC</u>	<u>%REC CL</u>	<u>RPD</u>	<u>RPD CL</u>	<u>Qualifiers</u>
o-Phosphate (as P)	EPA 300.0	10-09-1674-1	09/23/10	N/A	91	94	80-120	3	0-20	
Carbon, Total Organic	SM 5310 D	10-09-1998-1	09/28/10	N/A	93	92	75-125	1	0-25	

RPD - Relative Percent Difference , CL - Control Limit

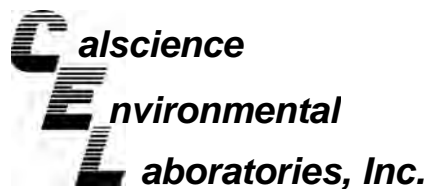

Quality Control - LCS/LCS Duplicate



Kiff Analytical
2795 2nd Street, Suite 300
Davis, CA 95616-6593

Date Received: N/A
Work Order No: 10-09-1711
Preparation: N/A
Method: RSK-175M

Project: NuStar Vancouver

Quality Control Sample ID	Matrix	Instrument	Date Prepared	Date Analyzed	LCS/LCSD Batch Number
099-12-661-349	Aqueous	GC 33	N/A	09/24/10	100924L01

<u>Parameter</u>	<u>LCS %REC</u>	<u>LCSD %REC</u>	<u>%REC CL</u>	<u>RPD</u>	<u>RPD CL</u>	<u>Qualifiers</u>
Ethane	96	97	80-120	1	0-20	
Methane	101	102	79-109	1	0-20	

RPD - Relative Percent Difference , CL - Control Limit

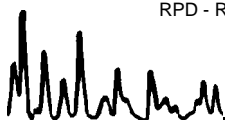

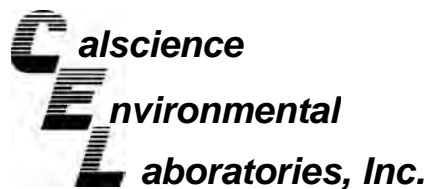

Quality Control - LCS/LCS Duplicate



Kiff Analytical
2795 2nd Street, Suite 300
Davis, CA 95616-6593

Date Received: N/A
Work Order No: 10-09-1711

Project: NuStar Vancouver

Matrix: Aqueous or Solid

<u>Parameter</u>	<u>Method</u>	<u>Quality Control</u> Sample ID	<u>Date</u> <u>Extracted</u>	<u>Date</u> <u>Analyzed</u>	<u>LCS %</u> <u>REC</u>	<u>LCSD %</u> <u>REC</u>	<u>%REC</u> <u>CL</u>	<u>RPD</u>	<u>RPD</u> <u>CL</u>	<u>Qual</u>
o-Phosphate (as P)	EPA 300.0	099-12-906-1,282	N/A	09/23/10	97	100	90-110	4	0-15	
Ammonia (as N)	SM 4500-NH3 B	099-12-814-792	09/27/10	09/27/10	99	97	80-120	1	0-20	

RPD - Relative Percent Difference , CL - Control Limit



Kiff Analytical
 2795 2nd Street, Suite 300
 Davis, CA 95616-6593

Date Received: N/A
 Work Order No: 10-09-1711

Project: NuStar Vancouver

Matrix: Aqueous or Solid

<u>Parameter</u>	<u>Method</u>	<u>Quality Control Sample ID</u>	<u>Date Analyzed</u>	<u>Date Extracted</u>	<u>Conc. Added</u>	<u>Conc. Recovered</u>	<u>LCS %Rec</u>	<u>%Rec. CL</u>	<u>Qualifiers</u>
Carbon, Total Organic	SM 5310 D	099-05-097-4,008	09/28/10	N/A	5	4.86	97	80-120	

RPD - Relative Percent Difference , CL - Control Limit

Glossary of Terms and Qualifiers



Work Order Number: 10-09-1711

<u>Qualifier</u>	<u>Definition</u>
*	See applicable analysis comment.
<	Less than the indicated value.
>	Greater than the indicated value.
1	Surrogate compound recovery was out of control due to a required sample dilution, therefore, the sample data was reported without further clarification.
2	Surrogate compound recovery was out of control due to matrix interference. The associated method blank surrogate spike compound was in control and, therefore, the sample data was reported without further clarification.
3	Recovery of the Matrix Spike (MS) or Matrix Spike Duplicate (MSD) compound was out of control due to matrix interference. The associated LCS and/or LCSD was in control and, therefore, the sample data was reported without further clarification.
4	The MS/MSD RPD was out of control due to matrix interference. The LCS/LCSD RPD was in control and, therefore, the sample data was reported without further clarification.
5	The PDS/PDSD or PES/PESD associated with this batch of samples was out of control due to a matrix interference effect. The associated batch LCS/LCSD was in control and, hence, the associated sample data was reported without further clarification.
B	Analyte was present in the associated method blank.
E	Concentration exceeds the calibration range.
J	Analyte was detected at a concentration below the reporting limit and above the laboratory method detection limit. Reported value is estimated.
ME	LCS Recovery Percentage is within LCS ME Control Limit range.
ND	Parameter not detected at the indicated reporting limit.
Q	Spike recovery and RPD control limits do not apply resulting from the parameter concentration in the sample exceeding the spike concentration by a factor of four or greater.
X	% Recovery and/or RPD out-of-range.
Z	Analyte presence was not confirmed by second column or GC/MS analysis. Solid - Unless otherwise indicated, solid sample data is reported on a wet weight basis, not corrected for % moisture.



1711



800.334.5000
ontrac.com



D10010317594219

Date Printed 9/22/2010

Tracking#D10010317594219

Shipped From:
KIFF ANALYTICAL
2795 2ND STREET 300
DAVIS, CA 95616

Sent By: SAMPLE RECEIVING
Phone#: (530)297-4800
wgt(lbs): 10
Reference: SUB SAMPLES
Reference 2:

<p><i>Ship To Company:</i> CALSCIENCE ENVIRONMENTAL LABS 7440 LINCOLN WAY GARDEN GROVE, CA 92841 SAMPLE RECEIVING (714)895-5494</p> <p>B10207210772</p>	<p><i>Service:</i> S <i>Sort Code:</i> ORG</p> <p><i>Special Services:</i> Signature Required</p>
--	--

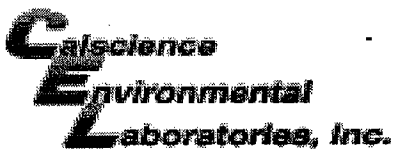

WORK ORDER #: 10-09-1711

SAMPLE RECEIPT FORM

Cooler 2 of 1

CLIENT: KIFF ANALYTICAL

DATE: 09/23/10

TEMPERATURE: Thermometer ID: SC1 (Criteria: 0.0°C – 6.0°C, not frozen)

Temperature 2.2 °C + 0.5°C (CF) = 2.7 °C Blank Sample

Sample(s) outside temperature criteria (PM/APM contacted by: _____).

Sample(s) outside temperature criteria but received on ice/chilled on same day of sampling.

Received at ambient temperature, placed on ice for transport by Courier.

Ambient Temperature: Air Filter Initial: WB

CUSTODY SEALS INTACT:

Cooler _____ No (Not Intact) Not Present N/A Initial: WB

Sample _____ No (Not Intact) Not Present Initial: PS

SAMPLE CONDITION:	Yes	No	N/A
Chain-Of-Custody (COC) document(s) received with samples.....	<input checked="" type="checkbox"/>	<input type="checkbox"/>	<input type="checkbox"/>
COC document(s) received complete.....	<input checked="" type="checkbox"/>	<input type="checkbox"/>	<input type="checkbox"/>
<input type="checkbox"/> Collection date/time, matrix, and/or # of containers logged in based on sample labels.			
<input type="checkbox"/> No analysis requested. <input type="checkbox"/> Not relinquished. <input type="checkbox"/> No date/time relinquished.			
Sampler's name indicated on COC.....	<input type="checkbox"/>	<input type="checkbox"/>	<input checked="" type="checkbox"/>
Sample container label(s) consistent with COC.....	<input checked="" type="checkbox"/>	<input type="checkbox"/>	<input type="checkbox"/>
Sample container(s) intact and good condition.....	<input checked="" type="checkbox"/>	<input type="checkbox"/>	<input type="checkbox"/>
Proper containers and sufficient volume for analyses requested.....	<input checked="" type="checkbox"/>	<input type="checkbox"/>	<input type="checkbox"/>
Analyses received within holding time.....	<input checked="" type="checkbox"/>	<input type="checkbox"/>	<input type="checkbox"/>
pH / Residual Chlorine / Dissolved Sulfide received within 24 hours.....	<input type="checkbox"/>	<input type="checkbox"/>	<input checked="" type="checkbox"/>
Proper preservation noted on COC or sample container.....	<input checked="" type="checkbox"/>	<input type="checkbox"/>	<input type="checkbox"/>
<input type="checkbox"/> Unpreserved vials received for Volatiles analysis			
Volatile analysis container(s) free of headspace.....	<input checked="" type="checkbox"/>	<input type="checkbox"/>	<input type="checkbox"/>
Tedlar bag(s) free of condensation.....	<input type="checkbox"/>	<input type="checkbox"/>	<input checked="" type="checkbox"/>

CONTAINER TYPE:

Solid: 4ozCGJ 8ozCGJ 16ozCGJ Sleeve (____) EnCores® TerraCores® _____

Water: VOA VOA²h VOAna₂ 125AGB 125AGBh 125AGBp 1AGB^{NSC 9-23-10} 1AGBna₂ 1AGBs²

500AGB 500AGJ 500AGJs 250AGB 250CGB 250CGBs 1PB 500PB 500PBna

250PB₅ 250PBn 125PB 125PBz_{na} 100PJ 100PJna₂ _____ _____ _____

Air: Tedlar® Summa® Other: _____ Trip Blank Lot#: _____ Labeled/Checked by: PS

Container: C: Clear A: Amber P: Plastic G: Glass J: Jar B: Bottle Z: Ziploc/Resealable Bag E: Envelope Reviewed by: PS

Preservative: h: HCL n: HNO₃ na₂: Na₂S₂O₃ na: NaOH p: H₃PO₄ s: H₂SO₄ z_{na}: ZnAc₂+NaOH f: Field-filtered Scanned by: PS

Exova
9240 Santa Fe Springs Road
Santa Fe Springs
California
USA
90670

T: +1 (562) 948-2225
F: +1 (562) 948-5850
E: info400@exova.com
W: www.exova.com



Testing. Advising. Assuring.

Certificate of Analysis

October 7, 2010

Kiff Analytical LLC
2795 Second St
Ste 300
Davis, CA 95616

Exova Job No: 125380
Purchase Order: 74644
Project Name: Water
Samples Received: One (1) Sample
Date Received: 09/23/2010

Attn: Scott Forbes

Analysis	Page
Organic Acids by SOP 4130, Rev 4	2 - 3

Michael Shelton
Technical Director

Patricia Metzger
Senior Chemist

Organic Acids by SOP 4130, Rev 4
Ion Chromatography-Suppressed Conductivity

Column: AS11-HC 250 mm x 4 mm, AG11-HC Guard 50 mm x 4 mm
Eluent: Sodium hydroxide, 2.4 mM, 1.2 mL/min
Injection: 300 µL
Detection: Suppressed Conductivity

The sample was diluted by 1:50 with water for analysis. Detection limits are corrected for the dilution factor necessary for analysis. Results were measured as the anion and converted to the acid by molecular weight.

Sample ID: Method Blank

Analyte	Parts Per Milion (mg/L)	Detection Limit
Acetic Acid	ND	0.009
Butyric Acid	ND	0.02
Lactic Acid	ND	0.01
Propionic Acid	ND	0.008

Date Analyzed: 10-04-10

Sample ID: CB-3 (35)

Analyte	Parts Per Milion (mg/L)	Detection Limit
Acetic Acid	ND	0.5
Butyric Acid	ND	1
Lactic Acid	ND	0.5
Propionic Acid	ND	0.4

Date Analyzed: 10-04-10

Calibration Summary

Sample ID: Laboratory Control Standard (2.00 ppm Second Source Standard)

Analyte	Result	% Rec	% Rec Limits
Acetate	1.94	97	90-110
Butyrate	2.06	103	90-110
Lactate	2.00	100	90-110
Propionate	1.99	100	90-110

Standard Curve (n=5) $r^2 \geq 0.999$ for all ions
Date Analyzed: 10-04-10

Quality Control Summary

Sample ID: CB-3 (35)

<u>Analyte</u>	<u>Sample Result</u>	<u>Spike Conc</u>	<u>Spike Result</u>	<u>Spike % Rec</u>	<u>Spike Duplicate Result</u>	<u>Spike Duplicate % Rec</u>	<u>Spike RPD</u>
Acetic Acid	ND	50.9	53.7	106	53.3	105	1
Butyric Acid	ND	50.6	52.6	104	52.4	104	< 1
Lactic Acid	ND	50.6	51.8	102	52.1	103	1
Propionic Acid	ND	50.7	53.3	105	53.0	105	1

QC Guidelines

<u>Analyte</u>	<u>% Recovery</u>	<u>RPD Limit</u>
Acetic Acid	69 - 140	20
Butyric Acid	63 - 148	26
Lactic Acid		
Propionic Acid		

Client: Kiff Analytical LLC
Job No.: 125380

Organic Acids by SOP 4130, Rev 4
Ion Chromatography-Suppressed Conductivity

Column: AS11-HC 250 mm x 4 mm, AG11-HC Guard 50 mm x 4 mm
Eluent: Sodium hydroxide, 2.4 mM, 1.2 mL/min
Injection: 300 µL
Detection: Suppressed Conductivity

The sample was diluted by 1:50 with water for analysis. Detection limits are corrected for the dilution factor necessary for analysis. Results were measured as the anion and converted to the acid by molecular weight.

Sample ID: Method Blank

<u>Analyte</u>	<u>Parts Per Milion (mg/L)</u>	<u>Detection Limit</u>
Acetic Acid	ND	0.009
Butyric Acid	ND	0.02
Lactic Acid	ND	0.01
Propionic Acid	ND	0.008

Date Analyzed: 10-04-10

Sample ID: CB-3 (35)

<u>Analyte</u>	<u>Parts Per Milion (mg/L)</u>	<u>Detection Limit</u>
Acetic Acid	ND	0.5
Butyric Acid	ND	1
Lactic Acid	ND	0.5
Propionic Acid	ND	0.4

Date Analyzed: 10-04-10

Calibration Summary

Sample ID: Laboratory Control Standard (2.00 ppm Second Source Standard)

<u>Analyte</u>	<u>Result</u>	<u>% Rec</u>	<u>% Rec Limits</u>
Acetate	1.94	97	90-110
Butyrate	2.06	103	90-110
Lactate	2.00	100	90-110
Propionate	1.99	100	90-110

Standard Curve (n=5) $r^2 \geq 0.999$ for all ions

Date Analyzed: 10-04-10

Client: Kiff Analytical LLC
Job No.: 125380

Quality Control Summary

Sample ID: CB-3 (35)

<u>Analyte</u>	<u>Sample Result</u>	<u>Spike Conc</u>	<u>Spike Result</u>	<u>Spike % Rec</u>	<u>Spike Duplicate Result</u>	<u>Spike Duplicate % Rec</u>	<u>Spike RPD</u>
Acetic Acid	ND	50.9	53.7	106	53.3	105	1
Butyric Acid	ND	50.6	52.6	104	52.4	104	< 1
Lactic Acid	ND	50.6	51.8	102	52.1	103	1
Propionic Acid	ND	50.7	53.3	105	53.0	105	1

QC Guidelines

<u>Analyte</u>	<u>% Recovery</u>	<u>RPD Limit</u>
Acetic Acid	69 - 140	20
Butyric Acid	63 - 148	26
Lactic Acid		
Propionic Acid		



Laboratory Results

Stephanie Bosze
Ash Creek Assoc.
3015 SW First Avenue
Portland, OR 97201-4707

Subject : 14 Soil Samples
Project Name : NuStar Vancouver Interim Action Confirmation Sampl
Project Number : E3WR-0028
P.O. Number : 4501259182-20

Dear Ms. Bosze,

Chemical analysis of the samples referenced above has been completed. Summaries of the data are contained on the following pages. Sample(s) were received under documented chain-of-custody. US EPA protocols for sample storage and preservation were followed. Testing procedures comply with the 2003 NELAC standard. All soil samples are reported on a total weight (wet weight) basis unless noted otherwise in the case narrative. Laboratory results relate only to the samples tested. This report may be freely reproduced in full, but may only be reproduced in part with the express permission of Kiff Analytical, LLC. Kiff Analytical, LLC is certified by the State of California under the National Environmental Laboratory Accreditation Program (NELAP), lab # 08263CA. If you have any questions regarding procedures or results, please call me at 530-297-4800.

Sincerely,



Joel Kiff

Subject : 14 Soil Samples
Project Name : NuStar Vancouver Interim Action Confirmation Sampl
Project Number : E3WR-0028
P.O. Number : 4501259182-20

Case Narrative

Methanol extracts of soil samples were subsampled prior to weighing for determining the soil mass present. 100 microliter aliquots were removed from each extract. To compensate for this, an adjustment of 0.08g was included in the mass calculation. This scenario applies to samples CB-1 (9), CB-1 (29.5), CB-2 (9.5), CB-2 (42), CB-3 (9), CB-3 (18), CB-3 (29), CB-4 (18), and CB-4 (38.5) by EPA Method 8260B.

The Bromomethane Reporting Limit has been raised for samples CB-1 (9), CB-1 (29.5), CB-2 (9.5), CB-2 (42), CB-3 (18), and CB-3 (29) due to a matrix effect.

Matrix Spike/Matrix Spike Duplicate results associated with samples CB-1 (9), CB-1 (29.5), CB-2 (42), CB-3 (18), CB-3 (29), and CB-4 (38.5) for the analytes 1,2,3-Trichlorobenzene, 1,2,4-Trichlorobenzene, Hexachlorobutadiene, and Naphthalene were outside of control limits. This may indicate a bias for the sample that was spiked. Since the LCS recoveries were within control limits, no data are flagged.

Matrix Spike/Matrix Spike Duplicate results associated with samples CB-1 (9), CB-1 (17.5), CB-1 (37.5), CB-2 (9.5), CB-2 (18), CB-2 (28), CB-3 (9), CB-4 (18), and CB-4 (28) for the analytes 1,1,1,2-Tetrachloroethane, 1,2,3-Trichlorobenzene, 1,2,4-Trichlorobenzene, 1,2,4-Trimethylbenzene, 1,2-Dichlorobenzene, 1,3,5-Trimethylbenzene, 1,3-Dichlorobenzene, 1,4-Dichlorobenzene, 2+4-Chlorotoluene, Bromobenzene, Chlorobenzene, Hexachlorobutadiene, Isopropyl benzene, Naphthalene, Styrene, c-1,3-Dichloropropene, n-butylbenzene, n-propylbenzene, p-isopropyltoluene, sec-butylbenzene, t-1,3-Dichloropropene, and tert-butylbenzene were outside of control limits. This may indicate a bias for the sample that was spiked. Since the LCS recoveries were within control limits, no data are flagged.

All sample results are reported on a Dry Weight basis.

The chain of custody indicates samples were frozen in the field and shipped at below zero temperatures. However, samples were 5.2 degrees C upon receipt, and therefore unpreserved samples were tested within 48 hours of receipt by the lab.

A version of this report was previously issued on 09/30/2010. This revised version replaces that report.

Sample : **CB-1 (9)**

Project Name : **NuStar Vancouver Interim Action Confirmation Sampl**

Project Number : **E3WR-0028**

Lab Number : 74661-01

Matrix : Soil

Sample Date :09/20/2010

Analysis Method: EPA 8260B

Parameter	Measured Value	Method Reporting Limit	Units	Date/Time Analyzed
Dichlorodifluoromethane	< 0.040	0.040	mg/Kg	09/23/10 21:03
Chloromethane	< 0.040	0.040	mg/Kg	09/23/10 21:03
Vinyl Chloride	< 0.040	0.040	mg/Kg	09/23/10 21:03
Bromomethane	< 5.0	5.0	mg/Kg	09/23/10 21:03
Chloroethane	< 0.040	0.040	mg/Kg	09/23/10 21:03
Trichlorofluoromethane	< 0.040	0.040	mg/Kg	09/23/10 21:03
1,1-Dichloroethene	< 0.040	0.040	mg/Kg	09/23/10 21:03
Methylene Chloride	< 0.040	0.040	mg/Kg	09/23/10 21:03
trans-1,2-Dichloroethene	< 0.040	0.040	mg/Kg	09/23/10 21:03
1,1-Dichloroethane	< 0.040	0.040	mg/Kg	09/23/10 21:03
2,2-Dichloropropane	< 0.040	0.040	mg/Kg	09/23/10 21:03
cis-1,2-Dichloroethene	< 0.040	0.040	mg/Kg	09/23/10 21:03
Chloroform	< 0.040	0.040	mg/Kg	09/23/10 21:03
Bromochloromethane	< 0.040	0.040	mg/Kg	09/23/10 21:03
1,1,1-Trichloroethane	< 4.0	4.0	mg/Kg	09/24/10 15:40
1,1-Dichloropropene	< 0.040	0.040	mg/Kg	09/23/10 21:03
1,2-Dichloroethane	< 0.040	0.040	mg/Kg	09/23/10 21:03
Carbon Tetrachloride	< 0.040	0.040	mg/Kg	09/23/10 21:03
Benzene	< 0.040	0.040	mg/Kg	09/23/10 21:03
Trichloroethene	< 4.0	4.0	mg/Kg	09/24/10 15:40
1,2-Dichloropropane	< 0.040	0.040	mg/Kg	09/23/10 21:03
Bromodichloromethane	< 0.040	0.040	mg/Kg	09/23/10 21:03
Dibromomethane	< 0.040	0.040	mg/Kg	09/23/10 21:03
cis-1,3-Dichloropropene	< 0.040	0.040	mg/Kg	09/23/10 21:03
Toluene	< 0.040	0.040	mg/Kg	09/23/10 21:03
trans-1,3-Dichloropropene	< 0.040	0.040	mg/Kg	09/23/10 21:03
1,1,2-Trichloroethane	< 0.040	0.040	mg/Kg	09/23/10 21:03
1,3-Dichloropropane	< 0.040	0.040	mg/Kg	09/23/10 21:03
Tetrachloroethene	6700	70	mg/Kg	09/28/10 00:24
Dibromochloromethane	< 0.040	0.040	mg/Kg	09/23/10 21:03
1,2-Dibromoethane	< 0.040	0.040	mg/Kg	09/23/10 21:03
Chlorobenzene	< 0.040	0.040	mg/Kg	09/23/10 21:03
1,1,1,2-Tetrachloroethane	< 4.0	4.0	mg/Kg	09/24/10 15:40
Ethylbenzene	< 4.0	4.0	mg/Kg	09/24/10 15:40

Sample : **CB-1 (9)**

Project Name : **NuStar Vancouver Interim Action Confirmation Sampl**

Project Number : **E3WR-0028**

Lab Number : 74661-01

Matrix : Soil

Sample Date :09/20/2010

Analysis Method: EPA 8260B

Parameter	Measured Value	Method Reporting Limit	Units	Date/Time Analyzed
P,M-Xylene	< 0.040	0.040	mg/Kg	09/23/10 21:03
O-Xylene	< 4.0	4.0	mg/Kg	09/24/10 15:40
Styrene	< 0.040	0.040	mg/Kg	09/23/10 21:03
Isopropyl benzene	< 0.040	0.040	mg/Kg	09/23/10 21:03
Bromoform	< 0.040	0.040	mg/Kg	09/23/10 21:03
1,1,2,2-Tetrachloroethane	< 0.050	0.050	mg/Kg	09/23/10 21:03
1,2,3-Trichloropropane	< 0.040	0.040	mg/Kg	09/23/10 21:03
n-Propylbenzene	< 0.040	0.040	mg/Kg	09/23/10 21:03
Bromobenzene	< 0.040	0.040	mg/Kg	09/23/10 21:03
1,3,5-Trimethylbenzene	< 0.040	0.040	mg/Kg	09/23/10 21:03
2+4-Chlorotoluene	< 0.070	0.070	mg/Kg	09/23/10 21:03
tert-Butylbenzene	< 0.040	0.040	mg/Kg	09/23/10 21:03
1,2,4-Trimethylbenzene	< 0.040	0.040	mg/Kg	09/23/10 21:03
sec-Butylbenzene	< 0.040	0.040	mg/Kg	09/23/10 21:03
p-Isopropyltoluene	< 4.0	4.0	mg/Kg	09/24/10 15:40
1,3-Dichlorobenzene	< 0.040	0.040	mg/Kg	09/23/10 21:03
1,4-Dichlorobenzene	< 0.040	0.040	mg/Kg	09/23/10 21:03
n-Butylbenzene	< 0.040	0.040	mg/Kg	09/23/10 21:03
1,2-Dichlorobenzene	< 0.040	0.040	mg/Kg	09/23/10 21:03
1,2-Dibromo-3-chloropropane	< 0.040	0.040	mg/Kg	09/23/10 21:03
1,2,4-Trichlorobenzene	< 0.040	0.040	mg/Kg	09/23/10 21:03
Hexachlorobutadiene	< 0.040	0.040	mg/Kg	09/23/10 21:03
Naphthalene	< 0.040	0.040	mg/Kg	09/23/10 21:03
1,2,3-Trichlorobenzene	< 0.040	0.040	mg/Kg	09/23/10 21:03
1,2-Dichloroethane-d4 (Surr)	95.2		% Recovery	09/23/10 21:03
4-Bromofluorobenzene (Surr)	100		% Recovery	09/23/10 21:03
Toluene - d8 (Surr)	99.0		% Recovery	09/23/10 21:03

Sample : CB-1 (29.5)

Project Name : NuStar Vancouver Interim Action Confirmation Sampl

Project Number : E3WR-0028

Lab Number : 74661-02

Matrix : Soil

Sample Date :09/20/2010

Analysis Method: EPA 8260B

Parameter	Measured Value	Method Reporting Limit	Units	Date/Time Analyzed
Dichlorodifluoromethane	< 0.040	0.040	mg/Kg	09/23/10 21:40
Chloromethane	< 0.040	0.040	mg/Kg	09/23/10 21:40
Vinyl Chloride	< 0.040	0.040	mg/Kg	09/23/10 21:40
Bromomethane	< 2.0	2.0	mg/Kg	09/23/10 21:40
Chloroethane	< 0.040	0.040	mg/Kg	09/23/10 21:40
Trichlorofluoromethane	< 0.040	0.040	mg/Kg	09/23/10 21:40
1,1-Dichloroethene	< 0.040	0.040	mg/Kg	09/23/10 21:40
Methylene Chloride	< 0.040	0.040	mg/Kg	09/23/10 21:40
trans-1,2-Dichloroethene	< 0.040	0.040	mg/Kg	09/23/10 21:40
1,1-Dichloroethane	< 0.040	0.040	mg/Kg	09/23/10 21:40
2,2-Dichloropropane	< 0.040	0.040	mg/Kg	09/23/10 21:40
cis-1,2-Dichloroethene	< 0.040	0.040	mg/Kg	09/23/10 21:40
Chloroform	< 0.040	0.040	mg/Kg	09/23/10 21:40
Bromochloromethane	< 0.040	0.040	mg/Kg	09/23/10 21:40
1,1,1-Trichloroethane	< 0.040	0.040	mg/Kg	09/23/10 21:40
1,1-Dichloropropene	< 0.040	0.040	mg/Kg	09/23/10 21:40
1,2-Dichloroethane	< 0.040	0.040	mg/Kg	09/23/10 21:40
Carbon Tetrachloride	< 0.040	0.040	mg/Kg	09/23/10 21:40
Benzene	< 0.040	0.040	mg/Kg	09/23/10 21:40
Trichloroethene	< 0.040	0.040	mg/Kg	09/23/10 21:40
1,2-Dichloropropane	< 0.040	0.040	mg/Kg	09/23/10 21:40
Bromodichloromethane	< 0.040	0.040	mg/Kg	09/23/10 21:40
Dibromomethane	< 0.040	0.040	mg/Kg	09/23/10 21:40
cis-1,3-Dichloropropene	< 0.040	0.040	mg/Kg	09/23/10 21:40
Toluene	< 0.040	0.040	mg/Kg	09/23/10 21:40
trans-1,3-Dichloropropene	< 0.040	0.040	mg/Kg	09/23/10 21:40
1,1,2-Trichloroethane	< 0.040	0.040	mg/Kg	09/23/10 21:40
1,3-Dichloropropane	< 0.040	0.040	mg/Kg	09/23/10 21:40
Tetrachloroethene	160	0.70	mg/Kg	09/25/10 13:24
Dibromochloromethane	< 0.040	0.040	mg/Kg	09/23/10 21:40
1,2-Dibromoethane	< 0.040	0.040	mg/Kg	09/23/10 21:40
Chlorobenzene	< 0.040	0.040	mg/Kg	09/23/10 21:40
1,1,1,2-Tetrachloroethane	< 0.040	0.040	mg/Kg	09/23/10 21:40
Ethylbenzene	< 0.040	0.040	mg/Kg	09/23/10 21:40

Sample : **CB-1 (29.5)**

Project Name : **NuStar Vancouver Interim Action Confirmation Sampl**

Project Number : **E3WR-0028**

Lab Number : 74661-02

Matrix : Soil

Sample Date :09/20/2010

Analysis Method: EPA 8260B

Parameter	Measured Value	Method Reporting Limit	Units	Date/Time Analyzed
P,M-Xylene	< 0.040	0.040	mg/Kg	09/23/10 21:40
O-Xylene	< 0.040	0.040	mg/Kg	09/23/10 21:40
Styrene	< 0.040	0.040	mg/Kg	09/23/10 21:40
Isopropyl benzene	< 0.040	0.040	mg/Kg	09/23/10 21:40
Bromoform	< 0.040	0.040	mg/Kg	09/23/10 21:40
1,1,2,2-Tetrachloroethane	< 0.040	0.040	mg/Kg	09/23/10 21:40
1,2,3-Trichloropropane	< 0.040	0.040	mg/Kg	09/23/10 21:40
n-Propylbenzene	< 0.040	0.040	mg/Kg	09/23/10 21:40
Bromobenzene	< 0.040	0.040	mg/Kg	09/23/10 21:40
1,3,5-Trimethylbenzene	< 0.040	0.040	mg/Kg	09/23/10 21:40
2+4-Chlorotoluene	< 0.070	0.070	mg/Kg	09/23/10 21:40
tert-Butylbenzene	< 0.040	0.040	mg/Kg	09/23/10 21:40
1,2,4-Trimethylbenzene	< 0.040	0.040	mg/Kg	09/23/10 21:40
sec-Butylbenzene	< 0.040	0.040	mg/Kg	09/23/10 21:40
p-Isopropyltoluene	< 0.040	0.040	mg/Kg	09/23/10 21:40
1,3-Dichlorobenzene	< 0.040	0.040	mg/Kg	09/23/10 21:40
1,4-Dichlorobenzene	< 0.040	0.040	mg/Kg	09/23/10 21:40
n-Butylbenzene	< 0.040	0.040	mg/Kg	09/23/10 21:40
1,2-Dichlorobenzene	< 0.040	0.040	mg/Kg	09/23/10 21:40
1,2-Dibromo-3-chloropropane	< 0.040	0.040	mg/Kg	09/23/10 21:40
1,2,4-Trichlorobenzene	< 0.040	0.040	mg/Kg	09/23/10 21:40
Hexachlorobutadiene	< 0.040	0.040	mg/Kg	09/23/10 21:40
Naphthalene	< 0.040	0.040	mg/Kg	09/23/10 21:40
1,2,3-Trichlorobenzene	< 0.040	0.040	mg/Kg	09/23/10 21:40
1,2-Dichloroethane-d4 (Surr)	97.8		% Recovery	09/23/10 21:40
4-Bromofluorobenzene (Surr)	99.3		% Recovery	09/23/10 21:40
Toluene - d8 (Surr)	99.3		% Recovery	09/23/10 21:40

Sample : CB-1 (17.5)

Project Name : NuStar Vancouver Interim Action Confirmation Sampl

Project Number : E3WR-0028

Lab Number : 74661-03

Matrix : Soil

Sample Date :09/20/2010

Analysis Method: EPA 8260B

Parameter	Measured Value	Method Reporting Limit	Units	Date/Time Analyzed
Dichlorodifluoromethane	< 0.030	0.030	mg/Kg	09/28/10 02:47
Chloromethane	< 0.030	0.030	mg/Kg	09/28/10 02:47
Vinyl Chloride	< 0.030	0.030	mg/Kg	09/28/10 02:47
Bromomethane	< 0.60	0.60	mg/Kg	09/28/10 02:47
Chloroethane	< 0.030	0.030	mg/Kg	09/28/10 02:47
Trichlorofluoromethane	< 0.030	0.030	mg/Kg	09/28/10 02:47
1,1-Dichloroethene	< 0.030	0.030	mg/Kg	09/28/10 02:47
Methylene Chloride	< 0.030	0.030	mg/Kg	09/28/10 02:47
trans-1,2-Dichloroethene	< 0.030	0.030	mg/Kg	09/28/10 02:47
1,1-Dichloroethane	< 0.030	0.030	mg/Kg	09/28/10 02:47
2,2-Dichloropropane	< 0.030	0.030	mg/Kg	09/28/10 02:47
cis-1,2-Dichloroethene	< 0.030	0.030	mg/Kg	09/28/10 02:47
Chloroform	< 0.030	0.030	mg/Kg	09/28/10 02:47
Bromochloromethane	< 0.030	0.030	mg/Kg	09/28/10 02:47
1,1,1-Trichloroethane	< 0.030	0.030	mg/Kg	09/28/10 02:47
1,1-Dichloropropene	< 0.030	0.030	mg/Kg	09/28/10 02:47
1,2-Dichloroethane	< 0.030	0.030	mg/Kg	09/28/10 02:47
Carbon Tetrachloride	< 0.030	0.030	mg/Kg	09/28/10 02:47
Benzene	< 0.030	0.030	mg/Kg	09/28/10 02:47
Trichloroethene	0.093	0.030	mg/Kg	09/28/10 02:47
1,2-Dichloropropane	< 0.030	0.030	mg/Kg	09/28/10 02:47
Bromodichloromethane	< 0.030	0.030	mg/Kg	09/28/10 02:47
Dibromomethane	< 0.030	0.030	mg/Kg	09/28/10 02:47
cis-1,3-Dichloropropene	< 0.030	0.030	mg/Kg	09/28/10 02:47
Toluene	< 0.030	0.030	mg/Kg	09/28/10 02:47
trans-1,3-Dichloropropene	< 0.030	0.030	mg/Kg	09/28/10 02:47
1,1,2-Trichloroethane	< 0.030	0.030	mg/Kg	09/28/10 02:47
1,3-Dichloropropane	< 0.030	0.030	mg/Kg	09/28/10 02:47
Tetrachloroethene	10	0.030	mg/Kg	09/28/10 02:47
Dibromochloromethane	< 0.030	0.030	mg/Kg	09/28/10 02:47
1,2-Dibromoethane	< 0.030	0.030	mg/Kg	09/28/10 02:47
Chlorobenzene	< 0.030	0.030	mg/Kg	09/28/10 02:47
1,1,1,2-Tetrachloroethane	< 0.030	0.030	mg/Kg	09/28/10 02:47
Ethylbenzene	< 0.030	0.030	mg/Kg	09/28/10 02:47

Sample : **CB-1 (17.5)**

Project Name : **NuStar Vancouver Interim Action Confirmation Sampl**

Project Number : **E3WR-0028**

Lab Number : 74661-03

Matrix : Soil

Sample Date :09/20/2010

Analysis Method: EPA 8260B

Parameter	Measured Value	Method Reporting Limit	Units	Date/Time Analyzed
P,M-Xylene	< 0.030	0.030	mg/Kg	09/28/10 02:47
O-Xylene	< 0.030	0.030	mg/Kg	09/28/10 02:47
Styrene	< 0.030	0.030	mg/Kg	09/28/10 02:47
Isopropyl benzene	< 0.030	0.030	mg/Kg	09/28/10 02:47
Bromoform	< 0.030	0.030	mg/Kg	09/28/10 02:47
1,1,2,2-Tetrachloroethane	< 0.030	0.030	mg/Kg	09/28/10 02:47
1,2,3-Trichloropropane	< 0.030	0.030	mg/Kg	09/28/10 02:47
n-Propylbenzene	< 0.030	0.030	mg/Kg	09/28/10 02:47
Bromobenzene	< 0.030	0.030	mg/Kg	09/28/10 02:47
1,3,5-Trimethylbenzene	< 0.030	0.030	mg/Kg	09/28/10 02:47
2+4-Chlorotoluene	< 0.060	0.060	mg/Kg	09/28/10 02:47
tert-Butylbenzene	< 0.030	0.030	mg/Kg	09/28/10 02:47
1,2,4-Trimethylbenzene	< 0.030	0.030	mg/Kg	09/28/10 02:47
sec-Butylbenzene	< 0.030	0.030	mg/Kg	09/28/10 02:47
p-Isopropyltoluene	< 0.030	0.030	mg/Kg	09/28/10 02:47
1,3-Dichlorobenzene	< 0.030	0.030	mg/Kg	09/28/10 02:47
1,4-Dichlorobenzene	< 0.030	0.030	mg/Kg	09/28/10 02:47
n-Butylbenzene	< 0.030	0.030	mg/Kg	09/28/10 02:47
1,2-Dichlorobenzene	< 0.030	0.030	mg/Kg	09/28/10 02:47
1,2-Dibromo-3-chloropropane	< 0.030	0.030	mg/Kg	09/28/10 02:47
1,2,4-Trichlorobenzene	< 0.030	0.030	mg/Kg	09/28/10 02:47
Hexachlorobutadiene	< 0.030	0.030	mg/Kg	09/28/10 02:47
Naphthalene	< 0.030	0.030	mg/Kg	09/28/10 02:47
1,2,3-Trichlorobenzene	< 0.030	0.030	mg/Kg	09/28/10 02:47
1,2-Dichloroethane-d4 (Surr)	101		% Recovery	09/28/10 02:47
4-Bromofluorobenzene (Surr)	101		% Recovery	09/28/10 02:47
Toluene - d8 (Surr)	99.2		% Recovery	09/28/10 02:47



Sample : CB-1 (37.5)

Project Name : NuStar Vancouver Interim Action Confirmation Sampl

Project Number : E3WR-0028

Lab Number : 74661-04

Matrix : Soil

Sample Date :09/20/2010

Analysis Method: EPA 8260B

Parameter	Measured Value	Method Reporting Limit	Units	Date/Time Analyzed
Dichlorodifluoromethane	< 0.0050	0.0050	mg/Kg	09/25/10 00:01
Chloromethane	< 0.0050	0.0050	mg/Kg	09/25/10 00:01
Vinyl Chloride	< 0.0050	0.0050	mg/Kg	09/25/10 00:01
Bromomethane	< 0.020	0.020	mg/Kg	09/25/10 00:01
Chloroethane	< 0.0050	0.0050	mg/Kg	09/25/10 00:01
Trichlorofluoromethane	< 0.0050	0.0050	mg/Kg	09/25/10 00:01
1,1-Dichloroethene	< 0.0050	0.0050	mg/Kg	09/25/10 00:01
Methylene Chloride	0.0057	0.0050	mg/Kg	09/25/10 00:01
trans-1,2-Dichloroethene	< 0.0050	0.0050	mg/Kg	09/25/10 00:01
1,1-Dichloroethane	< 0.0050	0.0050	mg/Kg	09/25/10 00:01
2,2-Dichloropropane	< 0.0050	0.0050	mg/Kg	09/25/10 00:01
cis-1,2-Dichloroethene	0.034	0.0050	mg/Kg	09/25/10 00:01
Chloroform	< 0.0050	0.0050	mg/Kg	09/25/10 00:01
Bromochloromethane	< 0.0050	0.0050	mg/Kg	09/25/10 00:01
1,1,1-Trichloroethane	< 0.0050	0.0050	mg/Kg	09/25/10 00:01
1,1-Dichloropropene	< 0.0050	0.0050	mg/Kg	09/25/10 00:01
1,2-Dichloroethane	< 0.0050	0.0050	mg/Kg	09/25/10 00:01
Carbon Tetrachloride	< 0.0050	0.0050	mg/Kg	09/25/10 00:01
Benzene	< 0.0050	0.0050	mg/Kg	09/25/10 00:01
Trichloroethene	0.069	0.0050	mg/Kg	09/25/10 00:01
1,2-Dichloropropane	< 0.0050	0.0050	mg/Kg	09/25/10 00:01
Bromodichloromethane	< 0.0050	0.0050	mg/Kg	09/25/10 00:01
Dibromomethane	< 0.0050	0.0050	mg/Kg	09/25/10 00:01
cis-1,3-Dichloropropene	< 0.0050	0.0050	mg/Kg	09/25/10 00:01
Toluene	< 0.0050	0.0050	mg/Kg	09/25/10 00:01
trans-1,3-Dichloropropene	< 0.0050	0.0050	mg/Kg	09/25/10 00:01
1,1,2-Trichloroethane	< 0.0050	0.0050	mg/Kg	09/25/10 00:01
1,3-Dichloropropane	< 0.0050	0.0050	mg/Kg	09/25/10 00:01
Tetrachloroethene	0.20	0.0050	mg/Kg	09/25/10 00:01
Dibromochloromethane	< 0.0050	0.0050	mg/Kg	09/25/10 00:01
1,2-Dibromoethane	< 0.0050	0.0050	mg/Kg	09/25/10 00:01
Chlorobenzene	< 0.0050	0.0050	mg/Kg	09/25/10 00:01
1,1,1,2-Tetrachloroethane	< 0.0050	0.0050	mg/Kg	09/25/10 00:01
Ethylbenzene	< 0.0050	0.0050	mg/Kg	09/25/10 00:01

Sample : **CB-1 (37.5)**

Project Name : **NuStar Vancouver Interim Action Confirmation Sampl**

Project Number : **E3WR-0028**

Lab Number : 74661-04

Matrix : Soil

Sample Date :09/20/2010

Analysis Method: EPA 8260B

Parameter	Measured Value	Method Reporting Limit	Units	Date/Time Analyzed
P,M-Xylene	< 0.0050	0.0050	mg/Kg	09/25/10 00:01
O-Xylene	< 0.0050	0.0050	mg/Kg	09/25/10 00:01
Styrene	< 0.0050	0.0050	mg/Kg	09/25/10 00:01
Isopropyl benzene	< 0.0050	0.0050	mg/Kg	09/25/10 00:01
Bromoform	< 0.0050	0.0050	mg/Kg	09/25/10 00:01
1,1,2,2-Tetrachloroethane	< 0.0050	0.0050	mg/Kg	09/25/10 00:01
1,2,3-Trichloropropane	< 0.0050	0.0050	mg/Kg	09/25/10 00:01
n-Propylbenzene	< 0.0050	0.0050	mg/Kg	09/25/10 00:01
Bromobenzene	< 0.0050	0.0050	mg/Kg	09/25/10 00:01
1,3,5-Trimethylbenzene	< 0.0050	0.0050	mg/Kg	09/25/10 00:01
2+4-Chlorotoluene	< 0.0050	0.0050	mg/Kg	09/25/10 00:01
tert-Butylbenzene	< 0.0050	0.0050	mg/Kg	09/25/10 00:01
1,2,4-Trimethylbenzene	< 0.0050	0.0050	mg/Kg	09/25/10 00:01
sec-Butylbenzene	< 0.0050	0.0050	mg/Kg	09/25/10 00:01
p-Isopropyltoluene	< 0.0050	0.0050	mg/Kg	09/25/10 00:01
1,3-Dichlorobenzene	< 0.0050	0.0050	mg/Kg	09/25/10 00:01
1,4-Dichlorobenzene	< 0.0050	0.0050	mg/Kg	09/25/10 00:01
n-Butylbenzene	< 0.0050	0.0050	mg/Kg	09/25/10 00:01
1,2-Dichlorobenzene	< 0.0050	0.0050	mg/Kg	09/25/10 00:01
1,2-Dibromo-3-chloropropane	< 0.0050	0.0050	mg/Kg	09/25/10 00:01
1,2,4-Trichlorobenzene	< 0.0050	0.0050	mg/Kg	09/25/10 00:01
Hexachlorobutadiene	< 0.0050	0.0050	mg/Kg	09/25/10 00:01
Naphthalene	< 0.0050	0.0050	mg/Kg	09/25/10 00:01
1,2,3-Trichlorobenzene	< 0.0050	0.0050	mg/Kg	09/25/10 00:01
1,2-Dichloroethane-d4 (Surr)	108		% Recovery	09/25/10 00:01
4-Bromofluorobenzene (Surr)	100		% Recovery	09/25/10 00:01
Toluene - d8 (Surr)	100		% Recovery	09/25/10 00:01

Sample : CB-2 (9.5)

Project Name : NuStar Vancouver Interim Action Confirmation Sampl

Project Number : E3WR-0028

Lab Number : 74661-05

Matrix : Soil

Sample Date :09/20/2010

Analysis Method: EPA 8260B

Parameter	Measured Value	Method Reporting Limit	Units	Date/Time Analyzed
Dichlorodifluoromethane	< 0.040	0.040	mg/Kg	09/28/10 05:07
Chloromethane	< 0.040	0.040	mg/Kg	09/28/10 05:07
Vinyl Chloride	< 0.040	0.040	mg/Kg	09/28/10 05:07
Bromomethane	< 0.80	0.80	mg/Kg	09/28/10 05:07
Chloroethane	< 0.040	0.040	mg/Kg	09/28/10 05:07
Trichlorofluoromethane	< 0.040	0.040	mg/Kg	09/28/10 05:07
1,1-Dichloroethene	< 0.040	0.040	mg/Kg	09/28/10 05:07
Methylene Chloride	< 0.040	0.040	mg/Kg	09/28/10 05:07
trans-1,2-Dichloroethene	< 0.040	0.040	mg/Kg	09/28/10 05:07
1,1-Dichloroethane	< 0.040	0.040	mg/Kg	09/28/10 05:07
2,2-Dichloropropane	< 0.040	0.040	mg/Kg	09/28/10 05:07
cis-1,2-Dichloroethene	< 0.040	0.040	mg/Kg	09/28/10 05:07
Chloroform	< 0.040	0.040	mg/Kg	09/28/10 05:07
Bromochloromethane	< 0.040	0.040	mg/Kg	09/28/10 05:07
1,1,1-Trichloroethane	< 0.040	0.040	mg/Kg	09/28/10 05:07
1,1-Dichloropropene	< 0.040	0.040	mg/Kg	09/28/10 05:07
1,2-Dichloroethane	< 0.040	0.040	mg/Kg	09/28/10 05:07
Carbon Tetrachloride	< 0.040	0.040	mg/Kg	09/28/10 05:07
Benzene	< 0.040	0.040	mg/Kg	09/28/10 05:07
Trichloroethene	< 0.040	0.040	mg/Kg	09/28/10 05:07
1,2-Dichloropropane	< 0.040	0.040	mg/Kg	09/28/10 05:07
Bromodichloromethane	< 0.040	0.040	mg/Kg	09/28/10 05:07
Dibromomethane	< 0.040	0.040	mg/Kg	09/28/10 05:07
cis-1,3-Dichloropropene	< 0.040	0.040	mg/Kg	09/28/10 05:07
Toluene	< 0.040	0.040	mg/Kg	09/28/10 05:07
trans-1,3-Dichloropropene	< 0.040	0.040	mg/Kg	09/28/10 05:07
1,1,2-Trichloroethane	< 0.040	0.040	mg/Kg	09/28/10 05:07
1,3-Dichloropropane	< 0.040	0.040	mg/Kg	09/28/10 05:07
Tetrachloroethene	130	0.70	mg/Kg	09/25/10 14:01
Dibromochloromethane	< 0.040	0.040	mg/Kg	09/28/10 05:07
1,2-Dibromoethane	< 0.040	0.040	mg/Kg	09/28/10 05:07
Chlorobenzene	< 0.040	0.040	mg/Kg	09/28/10 05:07
1,1,1,2-Tetrachloroethane	< 0.040	0.040	mg/Kg	09/28/10 05:07
Ethylbenzene	< 0.040	0.040	mg/Kg	09/28/10 05:07

Sample : **CB-2 (9.5)**

Project Name : **NuStar Vancouver Interim Action Confirmation Sampl**

Project Number : **E3WR-0028**

Lab Number : 74661-05

Matrix : Soil

Sample Date :09/20/2010

Analysis Method: EPA 8260B

Parameter	Measured Value	Method Reporting Limit	Units	Date/Time Analyzed
P,M-Xylene	< 0.040	0.040	mg/Kg	09/28/10 05:07
O-Xylene	< 0.040	0.040	mg/Kg	09/28/10 05:07
Styrene	< 0.040	0.040	mg/Kg	09/28/10 05:07
Isopropyl benzene	< 0.040	0.040	mg/Kg	09/28/10 05:07
Bromoform	< 0.040	0.040	mg/Kg	09/28/10 05:07
1,1,2,2-Tetrachloroethane	< 0.040	0.040	mg/Kg	09/28/10 05:07
1,2,3-Trichloropropane	< 0.040	0.040	mg/Kg	09/28/10 05:07
n-Propylbenzene	< 0.040	0.040	mg/Kg	09/28/10 05:07
Bromobenzene	< 0.040	0.040	mg/Kg	09/28/10 05:07
1,3,5-Trimethylbenzene	< 0.040	0.040	mg/Kg	09/28/10 05:07
2+4-Chlorotoluene	< 0.070	0.070	mg/Kg	09/28/10 05:07
tert-Butylbenzene	< 0.040	0.040	mg/Kg	09/28/10 05:07
1,2,4-Trimethylbenzene	< 0.040	0.040	mg/Kg	09/28/10 05:07
sec-Butylbenzene	< 0.040	0.040	mg/Kg	09/28/10 05:07
p-Isopropyltoluene	< 0.040	0.040	mg/Kg	09/28/10 05:07
1,3-Dichlorobenzene	< 0.040	0.040	mg/Kg	09/28/10 05:07
1,4-Dichlorobenzene	< 0.040	0.040	mg/Kg	09/28/10 05:07
n-Butylbenzene	< 0.040	0.040	mg/Kg	09/28/10 05:07
1,2-Dichlorobenzene	< 0.040	0.040	mg/Kg	09/28/10 05:07
1,2-Dibromo-3-chloropropane	< 0.040	0.040	mg/Kg	09/28/10 05:07
1,2,4-Trichlorobenzene	< 0.040	0.040	mg/Kg	09/28/10 05:07
Hexachlorobutadiene	< 0.040	0.040	mg/Kg	09/28/10 05:07
Naphthalene	< 0.040	0.040	mg/Kg	09/28/10 05:07
1,2,3-Trichlorobenzene	< 0.040	0.040	mg/Kg	09/28/10 05:07
1,2-Dichloroethane-d4 (Surr)	99.5		% Recovery	09/28/10 05:07
4-Bromofluorobenzene (Surr)	102		% Recovery	09/28/10 05:07
Toluene - d8 (Surr)	99.3		% Recovery	09/28/10 05:07

Sample : **CB-2 (18)**

Project Name : **NuStar Vancouver Interim Action Confirmation Sampl**

Project Number : **E3WR-0028**

Lab Number : 74661-06

Matrix : Soil

Sample Date :09/20/2010

Analysis Method: EPA 8260B

Parameter	Measured Value	Method Reporting Limit	Units	Date/Time Analyzed
Dichlorodifluoromethane	< 0.0050	0.0050	mg/Kg	09/24/10 16:48
Chloromethane	< 0.0050	0.0050	mg/Kg	09/24/10 16:48
Vinyl Chloride	< 0.0050	0.0050	mg/Kg	09/24/10 16:48
Bromomethane	< 0.020	0.020	mg/Kg	09/24/10 16:48
Chloroethane	< 0.0050	0.0050	mg/Kg	09/24/10 16:48
Trichlorofluoromethane	< 0.0050	0.0050	mg/Kg	09/24/10 16:48
1,1-Dichloroethene	< 0.0050	0.0050	mg/Kg	09/24/10 16:48
Methylene Chloride	0.0056	0.0050	mg/Kg	09/24/10 16:48
trans-1,2-Dichloroethene	< 0.0050	0.0050	mg/Kg	09/24/10 16:48
1,1-Dichloroethane	< 0.0050	0.0050	mg/Kg	09/24/10 16:48
2,2-Dichloropropane	< 0.0050	0.0050	mg/Kg	09/24/10 16:48
cis-1,2-Dichloroethene	< 0.0050	0.0050	mg/Kg	09/24/10 16:48
Chloroform	< 0.0050	0.0050	mg/Kg	09/24/10 16:48
Bromochloromethane	< 0.0050	0.0050	mg/Kg	09/24/10 16:48
1,1,1-Trichloroethane	< 0.0050	0.0050	mg/Kg	09/24/10 16:48
1,1-Dichloropropene	< 0.0050	0.0050	mg/Kg	09/24/10 16:48
1,2-Dichloroethane	< 0.0050	0.0050	mg/Kg	09/24/10 16:48
Carbon Tetrachloride	< 0.0050	0.0050	mg/Kg	09/24/10 16:48
Benzene	< 0.0050	0.0050	mg/Kg	09/24/10 16:48
Trichloroethene	< 0.0050	0.0050	mg/Kg	09/24/10 16:48
1,2-Dichloropropane	< 0.0050	0.0050	mg/Kg	09/24/10 16:48
Bromodichloromethane	< 0.0050	0.0050	mg/Kg	09/24/10 16:48
Dibromomethane	< 0.0050	0.0050	mg/Kg	09/24/10 16:48
cis-1,3-Dichloropropene	< 0.0050	0.0050	mg/Kg	09/24/10 16:48
Toluene	< 0.0050	0.0050	mg/Kg	09/24/10 16:48
trans-1,3-Dichloropropene	< 0.0050	0.0050	mg/Kg	09/24/10 16:48
1,1,2-Trichloroethane	< 0.0050	0.0050	mg/Kg	09/24/10 16:48
1,3-Dichloropropane	< 0.0050	0.0050	mg/Kg	09/24/10 16:48
Tetrachloroethene	0.019	0.0050	mg/Kg	09/24/10 16:48
Dibromochloromethane	< 0.0050	0.0050	mg/Kg	09/24/10 16:48
1,2-Dibromoethane	< 0.0050	0.0050	mg/Kg	09/24/10 16:48
Chlorobenzene	< 0.0050	0.0050	mg/Kg	09/24/10 16:48
1,1,1,2-Tetrachloroethane	< 0.0050	0.0050	mg/Kg	09/24/10 16:48
Ethylbenzene	< 0.0050	0.0050	mg/Kg	09/24/10 16:48

Sample : **CB-2 (18)**

Project Name : **NuStar Vancouver Interim Action Confirmation Sampl**

Project Number : **E3WR-0028**

Lab Number : 74661-06

Matrix : Soil

Sample Date :09/20/2010

Analysis Method: EPA 8260B

Parameter	Measured Value	Method Reporting Limit	Units	Date/Time Analyzed
P,M-Xylene	< 0.0050	0.0050	mg/Kg	09/24/10 16:48
O-Xylene	< 0.0050	0.0050	mg/Kg	09/24/10 16:48
Styrene	< 0.0050	0.0050	mg/Kg	09/24/10 16:48
Isopropyl benzene	< 0.0050	0.0050	mg/Kg	09/24/10 16:48
Bromoform	< 0.0050	0.0050	mg/Kg	09/24/10 16:48
1,1,2,2-Tetrachloroethane	< 0.0050	0.0050	mg/Kg	09/24/10 16:48
1,2,3-Trichloropropane	< 0.0050	0.0050	mg/Kg	09/24/10 16:48
n-Propylbenzene	< 0.0050	0.0050	mg/Kg	09/24/10 16:48
Bromobenzene	< 0.0050	0.0050	mg/Kg	09/24/10 16:48
1,3,5-Trimethylbenzene	< 0.0050	0.0050	mg/Kg	09/24/10 16:48
2+4-Chlorotoluene	< 0.0050	0.0050	mg/Kg	09/24/10 16:48
tert-Butylbenzene	< 0.0050	0.0050	mg/Kg	09/24/10 16:48
1,2,4-Trimethylbenzene	< 0.0050	0.0050	mg/Kg	09/24/10 16:48
sec-Butylbenzene	< 0.0050	0.0050	mg/Kg	09/24/10 16:48
p-Isopropyltoluene	< 0.0050	0.0050	mg/Kg	09/24/10 16:48
1,3-Dichlorobenzene	< 0.0050	0.0050	mg/Kg	09/24/10 16:48
1,4-Dichlorobenzene	< 0.0050	0.0050	mg/Kg	09/24/10 16:48
n-Butylbenzene	< 0.0050	0.0050	mg/Kg	09/24/10 16:48
1,2-Dichlorobenzene	< 0.0050	0.0050	mg/Kg	09/24/10 16:48
1,2-Dibromo-3-chloropropane	< 0.0050	0.0050	mg/Kg	09/24/10 16:48
1,2,4-Trichlorobenzene	< 0.0050	0.0050	mg/Kg	09/24/10 16:48
Hexachlorobutadiene	< 0.0050	0.0050	mg/Kg	09/24/10 16:48
Naphthalene	< 0.0050	0.0050	mg/Kg	09/24/10 16:48
1,2,3-Trichlorobenzene	< 0.0050	0.0050	mg/Kg	09/24/10 16:48
1,2-Dichloroethane-d4 (Surr)	109		% Recovery	09/24/10 16:48
4-Bromofluorobenzene (Surr)	97.4		% Recovery	09/24/10 16:48
Toluene - d8 (Surr)	99.0		% Recovery	09/24/10 16:48

Sample : CB-2 (28)

Project Name : NuStar Vancouver Interim Action Confirmation Sampl

Project Number : E3WR-0028

Lab Number : 74661-07

Matrix : Soil

Sample Date :09/20/2010

Analysis Method: EPA 8260B

Parameter	Measured Value	Method Reporting Limit	Units	Date/Time Analyzed
Dichlorodifluoromethane	< 0.0050	0.0050	mg/Kg	09/24/10 16:10
Chloromethane	< 0.0050	0.0050	mg/Kg	09/24/10 16:10
Vinyl Chloride	< 0.0050	0.0050	mg/Kg	09/24/10 16:10
Bromomethane	< 0.020	0.020	mg/Kg	09/24/10 16:10
Chloroethane	< 0.0050	0.0050	mg/Kg	09/24/10 16:10
Trichlorofluoromethane	< 0.0050	0.0050	mg/Kg	09/24/10 16:10
1,1-Dichloroethene	< 0.0050	0.0050	mg/Kg	09/24/10 16:10
Methylene Chloride	< 0.0050	0.0050	mg/Kg	09/24/10 16:10
trans-1,2-Dichloroethene	< 0.0050	0.0050	mg/Kg	09/24/10 16:10
1,1-Dichloroethane	< 0.0050	0.0050	mg/Kg	09/24/10 16:10
2,2-Dichloropropane	< 0.0050	0.0050	mg/Kg	09/24/10 16:10
cis-1,2-Dichloroethene	< 0.0050	0.0050	mg/Kg	09/24/10 16:10
Chloroform	< 0.0050	0.0050	mg/Kg	09/24/10 16:10
Bromochloromethane	< 0.0050	0.0050	mg/Kg	09/24/10 16:10
1,1,1-Trichloroethane	< 0.0050	0.0050	mg/Kg	09/24/10 16:10
1,1-Dichloropropene	< 0.0050	0.0050	mg/Kg	09/24/10 16:10
1,2-Dichloroethane	< 0.0050	0.0050	mg/Kg	09/24/10 16:10
Carbon Tetrachloride	< 0.0050	0.0050	mg/Kg	09/24/10 16:10
Benzene	< 0.0050	0.0050	mg/Kg	09/24/10 16:10
Trichloroethene	< 0.0050	0.0050	mg/Kg	09/24/10 16:10
1,2-Dichloropropane	< 0.0050	0.0050	mg/Kg	09/24/10 16:10
Bromodichloromethane	< 0.0050	0.0050	mg/Kg	09/24/10 16:10
Dibromomethane	< 0.0050	0.0050	mg/Kg	09/24/10 16:10
cis-1,3-Dichloropropene	< 0.0050	0.0050	mg/Kg	09/24/10 16:10
Toluene	< 0.0050	0.0050	mg/Kg	09/24/10 16:10
trans-1,3-Dichloropropene	< 0.0050	0.0050	mg/Kg	09/24/10 16:10
1,1,2-Trichloroethane	< 0.0050	0.0050	mg/Kg	09/24/10 16:10
1,3-Dichloropropane	< 0.0050	0.0050	mg/Kg	09/24/10 16:10
Tetrachloroethene	0.015	0.0050	mg/Kg	09/24/10 16:10
Dibromochloromethane	< 0.0050	0.0050	mg/Kg	09/24/10 16:10
1,2-Dibromoethane	< 0.0050	0.0050	mg/Kg	09/24/10 16:10
Chlorobenzene	< 0.0050	0.0050	mg/Kg	09/24/10 16:10
1,1,1,2-Tetrachloroethane	< 0.0050	0.0050	mg/Kg	09/24/10 16:10
Ethylbenzene	< 0.0050	0.0050	mg/Kg	09/24/10 16:10

Sample : **CB-2 (28)**

Project Name : **NuStar Vancouver Interim Action Confirmation Sampl**

Project Number : **E3WR-0028**

Lab Number : 74661-07

Matrix : Soil

Sample Date :09/20/2010

Analysis Method: EPA 8260B

Parameter	Measured Value	Method Reporting Limit	Units	Date/Time Analyzed
P,M-Xylene	< 0.0050	0.0050	mg/Kg	09/24/10 16:10
O-Xylene	< 0.0050	0.0050	mg/Kg	09/24/10 16:10
Styrene	< 0.0050	0.0050	mg/Kg	09/24/10 16:10
Isopropyl benzene	< 0.0050	0.0050	mg/Kg	09/24/10 16:10
Bromoform	< 0.0050	0.0050	mg/Kg	09/24/10 16:10
1,1,2,2-Tetrachloroethane	< 0.0050	0.0050	mg/Kg	09/24/10 16:10
1,2,3-Trichloropropane	< 0.0050	0.0050	mg/Kg	09/24/10 16:10
n-Propylbenzene	< 0.0050	0.0050	mg/Kg	09/24/10 16:10
Bromobenzene	< 0.0050	0.0050	mg/Kg	09/24/10 16:10
1,3,5-Trimethylbenzene	< 0.0050	0.0050	mg/Kg	09/24/10 16:10
2+4-Chlorotoluene	< 0.0050	0.0050	mg/Kg	09/24/10 16:10
tert-Butylbenzene	< 0.0050	0.0050	mg/Kg	09/24/10 16:10
1,2,4-Trimethylbenzene	< 0.0050	0.0050	mg/Kg	09/24/10 16:10
sec-Butylbenzene	< 0.0050	0.0050	mg/Kg	09/24/10 16:10
p-Isopropyltoluene	< 0.0050	0.0050	mg/Kg	09/24/10 16:10
1,3-Dichlorobenzene	< 0.0050	0.0050	mg/Kg	09/24/10 16:10
1,4-Dichlorobenzene	< 0.0050	0.0050	mg/Kg	09/24/10 16:10
n-Butylbenzene	< 0.0050	0.0050	mg/Kg	09/24/10 16:10
1,2-Dichlorobenzene	< 0.0050	0.0050	mg/Kg	09/24/10 16:10
1,2-Dibromo-3-chloropropane	< 0.0050	0.0050	mg/Kg	09/24/10 16:10
1,2,4-Trichlorobenzene	< 0.0050	0.0050	mg/Kg	09/24/10 16:10
Hexachlorobutadiene	< 0.0050	0.0050	mg/Kg	09/24/10 16:10
Naphthalene	< 0.0050	0.0050	mg/Kg	09/24/10 16:10
1,2,3-Trichlorobenzene	< 0.0050	0.0050	mg/Kg	09/24/10 16:10
1,2-Dichloroethane-d4 (Surr)	106		% Recovery	09/24/10 16:10
4-Bromofluorobenzene (Surr)	99.7		% Recovery	09/24/10 16:10
Toluene - d8 (Surr)	100		% Recovery	09/24/10 16:10

Sample : CB-2 (42)

Project Name : NuStar Vancouver Interim Action Confirmation Sampl

Project Number : E3WR-0028

Lab Number : 74661-08

Matrix : Soil

Sample Date :09/21/2010

Analysis Method: EPA 8260B

Parameter	Measured Value	Method Reporting Limit	Units	Date/Time Analyzed
Dichlorodifluoromethane	< 0.040	0.040	mg/Kg	09/24/10 01:12
Chloromethane	< 0.040	0.040	mg/Kg	09/24/10 01:12
Vinyl Chloride	< 0.040	0.040	mg/Kg	09/24/10 01:12
Bromomethane	< 0.80	0.80	mg/Kg	09/24/10 01:12
Chloroethane	< 0.040	0.040	mg/Kg	09/24/10 01:12
Trichlorofluoromethane	< 0.040	0.040	mg/Kg	09/24/10 01:12
1,1-Dichloroethene	0.062	0.040	mg/Kg	09/24/10 01:12
Methylene Chloride	< 0.040	0.040	mg/Kg	09/24/10 01:12
trans-1,2-Dichloroethene	0.049	0.040	mg/Kg	09/24/10 01:12
1,1-Dichloroethane	0.27	0.040	mg/Kg	09/24/10 01:12
2,2-Dichloropropane	< 0.040	0.040	mg/Kg	09/24/10 01:12
cis-1,2-Dichloroethene	1.9	0.040	mg/Kg	09/24/10 01:12
Chloroform	< 0.040	0.040	mg/Kg	09/24/10 01:12
Bromochloromethane	< 0.040	0.040	mg/Kg	09/24/10 01:12
1,1,1-Trichloroethane	0.30	0.040	mg/Kg	09/24/10 01:12
1,1-Dichloropropene	< 0.040	0.040	mg/Kg	09/24/10 01:12
1,2-Dichloroethane	< 0.040	0.040	mg/Kg	09/24/10 01:12
Carbon Tetrachloride	< 0.040	0.040	mg/Kg	09/24/10 01:12
Benzene	< 0.040	0.040	mg/Kg	09/24/10 01:12
Trichloroethene	4.7	0.040	mg/Kg	09/24/10 01:12
1,2-Dichloropropane	< 0.040	0.040	mg/Kg	09/24/10 01:12
Bromodichloromethane	< 0.040	0.040	mg/Kg	09/24/10 01:12
Dibromomethane	< 0.040	0.040	mg/Kg	09/24/10 01:12
cis-1,3-Dichloropropene	< 0.040	0.040	mg/Kg	09/24/10 01:12
Toluene	< 0.040	0.040	mg/Kg	09/24/10 01:12
trans-1,3-Dichloropropene	< 0.040	0.040	mg/Kg	09/24/10 01:12
1,1,2-Trichloroethane	< 0.040	0.040	mg/Kg	09/24/10 01:12
1,3-Dichloropropane	< 0.040	0.040	mg/Kg	09/24/10 01:12
Tetrachloroethene	42	0.40	mg/Kg	09/25/10 12:47
Dibromochloromethane	< 0.040	0.040	mg/Kg	09/24/10 01:12
1,2-Dibromoethane	< 0.040	0.040	mg/Kg	09/24/10 01:12
Chlorobenzene	< 0.040	0.040	mg/Kg	09/24/10 01:12
1,1,1,2-Tetrachloroethane	< 0.040	0.040	mg/Kg	09/24/10 01:12
Ethylbenzene	< 0.040	0.040	mg/Kg	09/24/10 01:12

Sample : **CB-2 (42)**

Project Name : **NuStar Vancouver Interim Action Confirmation Sampl**

Project Number : **E3WR-0028**

Lab Number : 74661-08

Matrix : Soil

Sample Date :09/21/2010

Analysis Method: EPA 8260B

Parameter	Measured Value	Method Reporting Limit	Units	Date/Time Analyzed
P,M-Xylene	< 0.040	0.040	mg/Kg	09/24/10 01:12
O-Xylene	< 0.040	0.040	mg/Kg	09/24/10 01:12
Styrene	< 0.040	0.040	mg/Kg	09/24/10 01:12
Isopropyl benzene	< 0.040	0.040	mg/Kg	09/24/10 01:12
Bromoform	< 0.040	0.040	mg/Kg	09/24/10 01:12
1,1,2,2-Tetrachloroethane	< 0.040	0.040	mg/Kg	09/24/10 01:12
1,2,3-Trichloropropane	< 0.040	0.040	mg/Kg	09/24/10 01:12
n-Propylbenzene	< 0.040	0.040	mg/Kg	09/24/10 01:12
Bromobenzene	< 0.040	0.040	mg/Kg	09/24/10 01:12
1,3,5-Trimethylbenzene	< 0.040	0.040	mg/Kg	09/24/10 01:12
2+4-Chlorotoluene	< 0.070	0.070	mg/Kg	09/24/10 01:12
tert-Butylbenzene	< 0.040	0.040	mg/Kg	09/24/10 01:12
1,2,4-Trimethylbenzene	< 0.040	0.040	mg/Kg	09/24/10 01:12
sec-Butylbenzene	< 0.040	0.040	mg/Kg	09/24/10 01:12
p-Isopropyltoluene	< 0.040	0.040	mg/Kg	09/24/10 01:12
1,3-Dichlorobenzene	< 0.040	0.040	mg/Kg	09/24/10 01:12
1,4-Dichlorobenzene	< 0.040	0.040	mg/Kg	09/24/10 01:12
n-Butylbenzene	< 0.040	0.040	mg/Kg	09/24/10 01:12
1,2-Dichlorobenzene	< 0.040	0.040	mg/Kg	09/24/10 01:12
1,2-Dibromo-3-chloropropane	< 0.040	0.040	mg/Kg	09/24/10 01:12
1,2,4-Trichlorobenzene	< 0.040	0.040	mg/Kg	09/24/10 01:12
Hexachlorobutadiene	< 0.040	0.040	mg/Kg	09/24/10 01:12
Naphthalene	< 0.040	0.040	mg/Kg	09/24/10 01:12
1,2,3-Trichlorobenzene	< 0.040	0.040	mg/Kg	09/24/10 01:12
1,2-Dichloroethane-d4 (Surr)	96.1		% Recovery	09/24/10 01:12
4-Bromofluorobenzene (Surr)	100		% Recovery	09/24/10 01:12
Toluene - d8 (Surr)	98.9		% Recovery	09/24/10 01:12

Sample : **CB-3 (9)**

Project Name : **NuStar Vancouver Interim Action Confirmation Sampl**

Project Number : **E3WR-0028**

Lab Number : 74661-09

Matrix : Soil

Sample Date :09/21/2010

Analysis Method: EPA 8260B

Parameter	Measured Value	Method Reporting Limit	Units	Date/Time Analyzed
Dichlorodifluoromethane	< 0.0050	0.0050	mg/Kg	09/25/10 11:11
Chloromethane	< 0.0050	0.0050	mg/Kg	09/25/10 11:11
Vinyl Chloride	< 0.0050	0.0050	mg/Kg	09/25/10 11:11
Bromomethane	< 0.020	0.020	mg/Kg	09/25/10 11:11
Chloroethane	< 0.0050	0.0050	mg/Kg	09/25/10 11:11
Trichlorofluoromethane	< 0.0050	0.0050	mg/Kg	09/25/10 11:11
1,1-Dichloroethene	< 0.0050	0.0050	mg/Kg	09/25/10 11:11
Methylene Chloride	< 0.0050	0.0050	mg/Kg	09/25/10 11:11
trans-1,2-Dichloroethene	< 0.0050	0.0050	mg/Kg	09/25/10 11:11
1,1-Dichloroethane	< 0.0050	0.0050	mg/Kg	09/25/10 11:11
2,2-Dichloropropane	< 0.0050	0.0050	mg/Kg	09/25/10 11:11
cis-1,2-Dichloroethene	< 0.0050	0.0050	mg/Kg	09/25/10 11:11
Chloroform	< 0.0050	0.0050	mg/Kg	09/25/10 11:11
Bromochloromethane	< 0.0050	0.0050	mg/Kg	09/25/10 11:11
1,1,1-Trichloroethane	< 0.0050	0.0050	mg/Kg	09/25/10 11:11
1,1-Dichloropropene	< 0.0050	0.0050	mg/Kg	09/25/10 11:11
1,2-Dichloroethane	< 0.0050	0.0050	mg/Kg	09/25/10 11:11
Carbon Tetrachloride	< 0.0050	0.0050	mg/Kg	09/25/10 11:11
Benzene	< 0.0050	0.0050	mg/Kg	09/25/10 11:11
Trichloroethene	0.0069	0.0050	mg/Kg	09/25/10 11:11
1,2-Dichloropropane	< 0.0050	0.0050	mg/Kg	09/25/10 11:11
Bromodichloromethane	< 0.0050	0.0050	mg/Kg	09/25/10 11:11
Dibromomethane	< 0.0050	0.0050	mg/Kg	09/25/10 11:11
cis-1,3-Dichloropropene	< 0.0050	0.0050	mg/Kg	09/25/10 11:11
Toluene	< 0.0050	0.0050	mg/Kg	09/25/10 11:11
trans-1,3-Dichloropropene	< 0.0050	0.0050	mg/Kg	09/25/10 11:11
1,1,2-Trichloroethane	< 0.0050	0.0050	mg/Kg	09/25/10 11:11
1,3-Dichloropropane	< 0.0050	0.0050	mg/Kg	09/25/10 11:11
Tetrachloroethene	1.8	0.040	mg/Kg	09/28/10 01:36
Dibromochloromethane	< 0.0050	0.0050	mg/Kg	09/25/10 11:11
1,2-Dibromoethane	< 0.0050	0.0050	mg/Kg	09/25/10 11:11
Chlorobenzene	< 0.0050	0.0050	mg/Kg	09/25/10 11:11
1,1,1,2-Tetrachloroethane	< 0.0050	0.0050	mg/Kg	09/25/10 11:11
Ethylbenzene	< 0.0050	0.0050	mg/Kg	09/25/10 11:11

Sample : **CB-3 (9)**

Project Name : **NuStar Vancouver Interim Action Confirmation Sampl**

Project Number : **E3WR-0028**

Lab Number : 74661-09

Matrix : Soil

Sample Date :09/21/2010

Analysis Method: EPA 8260B

Parameter	Measured Value	Method Reporting Limit	Units	Date/Time Analyzed
P,M-Xylene	< 0.0050	0.0050	mg/Kg	09/25/10 11:11
O-Xylene	< 0.0050	0.0050	mg/Kg	09/25/10 11:11
Styrene	< 0.0050	0.0050	mg/Kg	09/25/10 11:11
Isopropyl benzene	< 0.0050	0.0050	mg/Kg	09/25/10 11:11
Bromoform	< 0.0050	0.0050	mg/Kg	09/25/10 11:11
1,1,2,2-Tetrachloroethane	< 0.0050	0.0050	mg/Kg	09/25/10 11:11
1,2,3-Trichloropropane	< 0.0050	0.0050	mg/Kg	09/25/10 11:11
n-Propylbenzene	< 0.0050	0.0050	mg/Kg	09/25/10 11:11
Bromobenzene	< 0.0050	0.0050	mg/Kg	09/25/10 11:11
1,3,5-Trimethylbenzene	< 0.0050	0.0050	mg/Kg	09/25/10 11:11
2+4-Chlorotoluene	< 0.0050	0.0050	mg/Kg	09/25/10 11:11
tert-Butylbenzene	< 0.0050	0.0050	mg/Kg	09/25/10 11:11
1,2,4-Trimethylbenzene	< 0.0050	0.0050	mg/Kg	09/25/10 11:11
sec-Butylbenzene	< 0.0050	0.0050	mg/Kg	09/25/10 11:11
p-Isopropyltoluene	< 0.0050	0.0050	mg/Kg	09/25/10 11:11
1,3-Dichlorobenzene	< 0.0050	0.0050	mg/Kg	09/25/10 11:11
1,4-Dichlorobenzene	< 0.0050	0.0050	mg/Kg	09/25/10 11:11
n-Butylbenzene	< 0.0050	0.0050	mg/Kg	09/25/10 11:11
1,2-Dichlorobenzene	< 0.0050	0.0050	mg/Kg	09/25/10 11:11
1,2-Dibromo-3-chloropropane	< 0.0050	0.0050	mg/Kg	09/25/10 11:11
1,2,4-Trichlorobenzene	< 0.0050	0.0050	mg/Kg	09/25/10 11:11
Hexachlorobutadiene	< 0.0050	0.0050	mg/Kg	09/25/10 11:11
Naphthalene	< 0.0050	0.0050	mg/Kg	09/25/10 11:11
1,2,3-Trichlorobenzene	< 0.0050	0.0050	mg/Kg	09/25/10 11:11
1,2-Dichloroethane-d4 (Surr)	106		% Recovery	09/25/10 11:11
4-Bromofluorobenzene (Surr)	101		% Recovery	09/25/10 11:11
Toluene - d8 (Surr)	99.2		% Recovery	09/25/10 11:11

Sample : **CB-3 (18)**

Project Name : **NuStar Vancouver Interim Action Confirmation Sampl**

Project Number : **E3WR-0028**

Lab Number : 74661-10

Matrix : Soil

Sample Date :09/21/2010

Analysis Method: EPA 8260B

Parameter	Measured Value	Method Reporting Limit	Units	Date/Time Analyzed
Dichlorodifluoromethane	< 0.040	0.040	mg/Kg	09/24/10 02:23
Chloromethane	< 0.040	0.040	mg/Kg	09/24/10 02:23
Vinyl Chloride	< 0.040	0.040	mg/Kg	09/24/10 02:23
Bromomethane	< 1.0	1.0	mg/Kg	09/24/10 02:23
Chloroethane	< 0.040	0.040	mg/Kg	09/24/10 02:23
Trichlorofluoromethane	< 0.040	0.040	mg/Kg	09/24/10 02:23
1,1-Dichloroethene	< 0.040	0.040	mg/Kg	09/24/10 02:23
Methylene Chloride	< 0.040	0.040	mg/Kg	09/24/10 02:23
trans-1,2-Dichloroethene	< 0.040	0.040	mg/Kg	09/24/10 02:23
1,1-Dichloroethane	< 0.040	0.040	mg/Kg	09/24/10 02:23
2,2-Dichloropropane	< 0.040	0.040	mg/Kg	09/24/10 02:23
cis-1,2-Dichloroethene	< 0.040	0.040	mg/Kg	09/24/10 02:23
Chloroform	< 0.040	0.040	mg/Kg	09/24/10 02:23
Bromochloromethane	< 0.040	0.040	mg/Kg	09/24/10 02:23
1,1,1-Trichloroethane	< 0.040	0.040	mg/Kg	09/24/10 02:23
1,1-Dichloropropene	< 0.040	0.040	mg/Kg	09/24/10 02:23
1,2-Dichloroethane	< 0.040	0.040	mg/Kg	09/24/10 02:23
Carbon Tetrachloride	< 0.040	0.040	mg/Kg	09/24/10 02:23
Benzene	< 0.040	0.040	mg/Kg	09/24/10 02:23
Trichloroethene	0.18	0.040	mg/Kg	09/24/10 02:23
1,2-Dichloropropane	< 0.040	0.040	mg/Kg	09/24/10 02:23
Bromodichloromethane	< 0.040	0.040	mg/Kg	09/24/10 02:23
Dibromomethane	< 0.040	0.040	mg/Kg	09/24/10 02:23
cis-1,3-Dichloropropene	< 0.040	0.040	mg/Kg	09/24/10 02:23
Toluene	< 0.040	0.040	mg/Kg	09/24/10 02:23
trans-1,3-Dichloropropene	< 0.040	0.040	mg/Kg	09/24/10 02:23
1,1,2-Trichloroethane	< 0.040	0.040	mg/Kg	09/24/10 02:23
1,3-Dichloropropane	< 0.040	0.040	mg/Kg	09/24/10 02:23
Tetrachloroethene	24	0.40	mg/Kg	09/25/10 12:13
Dibromochloromethane	< 0.040	0.040	mg/Kg	09/24/10 02:23
1,2-Dibromoethane	< 0.040	0.040	mg/Kg	09/24/10 02:23
Chlorobenzene	< 0.040	0.040	mg/Kg	09/24/10 02:23
1,1,1,2-Tetrachloroethane	< 0.040	0.040	mg/Kg	09/24/10 02:23
Ethylbenzene	< 0.040	0.040	mg/Kg	09/24/10 02:23

Sample : **CB-3 (18)**

Project Name : **NuStar Vancouver Interim Action Confirmation Sampl**

Project Number : **E3WR-0028**

Lab Number : 74661-10

Matrix : Soil

Sample Date :09/21/2010

Analysis Method: EPA 8260B

Parameter	Measured Value	Method Reporting Limit	Units	Date/Time Analyzed
P,M-Xylene	< 0.040	0.040	mg/Kg	09/24/10 02:23
O-Xylene	< 0.040	0.040	mg/Kg	09/24/10 02:23
Styrene	< 0.040	0.040	mg/Kg	09/24/10 02:23
Isopropyl benzene	< 0.040	0.040	mg/Kg	09/24/10 02:23
Bromoform	< 0.040	0.040	mg/Kg	09/24/10 02:23
1,1,2,2-Tetrachloroethane	< 0.040	0.040	mg/Kg	09/24/10 02:23
1,2,3-Trichloropropane	< 0.040	0.040	mg/Kg	09/24/10 02:23
n-Propylbenzene	< 0.040	0.040	mg/Kg	09/24/10 02:23
Bromobenzene	< 0.040	0.040	mg/Kg	09/24/10 02:23
1,3,5-Trimethylbenzene	< 0.040	0.040	mg/Kg	09/24/10 02:23
2+4-Chlorotoluene	< 0.080	0.080	mg/Kg	09/24/10 02:23
tert-Butylbenzene	< 0.040	0.040	mg/Kg	09/24/10 02:23
1,2,4-Trimethylbenzene	< 0.040	0.040	mg/Kg	09/24/10 02:23
sec-Butylbenzene	< 0.040	0.040	mg/Kg	09/24/10 02:23
p-Isopropyltoluene	< 0.040	0.040	mg/Kg	09/24/10 02:23
1,3-Dichlorobenzene	< 0.040	0.040	mg/Kg	09/24/10 02:23
1,4-Dichlorobenzene	< 0.040	0.040	mg/Kg	09/24/10 02:23
n-Butylbenzene	< 0.040	0.040	mg/Kg	09/24/10 02:23
1,2-Dichlorobenzene	< 0.040	0.040	mg/Kg	09/24/10 02:23
1,2-Dibromo-3-chloropropane	< 0.040	0.040	mg/Kg	09/24/10 02:23
1,2,4-Trichlorobenzene	< 0.040	0.040	mg/Kg	09/24/10 02:23
Hexachlorobutadiene	< 0.040	0.040	mg/Kg	09/24/10 02:23
Naphthalene	< 0.040	0.040	mg/Kg	09/24/10 02:23
1,2,3-Trichlorobenzene	< 0.040	0.040	mg/Kg	09/24/10 02:23
1,2-Dichloroethane-d4 (Surr)	101		% Recovery	09/24/10 02:23
4-Bromofluorobenzene (Surr)	99.2		% Recovery	09/24/10 02:23
Toluene - d8 (Surr)	99.1		% Recovery	09/24/10 02:23

Sample : **CB-3 (29)**

Project Name : **NuStar Vancouver Interim Action Confirmation Sampl**

Project Number : **E3WR-0028**

Lab Number : 74661-11

Matrix : Soil

Sample Date :09/21/2010

Analysis Method: EPA 8260B

Parameter	Measured Value	Method Reporting Limit	Units	Date/Time Analyzed
Dichlorodifluoromethane	< 0.040	0.040	mg/Kg	09/24/10 02:57
Chloromethane	< 0.040	0.040	mg/Kg	09/24/10 02:57
Vinyl Chloride	< 0.040	0.040	mg/Kg	09/24/10 02:57
Bromomethane	< 0.80	0.80	mg/Kg	09/24/10 02:57
Chloroethane	< 0.040	0.040	mg/Kg	09/24/10 02:57
Trichlorofluoromethane	< 0.040	0.040	mg/Kg	09/24/10 02:57
1,1-Dichloroethene	< 0.040	0.040	mg/Kg	09/24/10 02:57
Methylene Chloride	< 0.040	0.040	mg/Kg	09/24/10 02:57
trans-1,2-Dichloroethene	< 0.040	0.040	mg/Kg	09/24/10 02:57
1,1-Dichloroethane	< 0.040	0.040	mg/Kg	09/24/10 02:57
2,2-Dichloropropane	< 0.040	0.040	mg/Kg	09/24/10 02:57
cis-1,2-Dichloroethene	0.23	0.040	mg/Kg	09/24/10 02:57
Chloroform	< 0.040	0.040	mg/Kg	09/24/10 02:57
Bromochloromethane	< 0.040	0.040	mg/Kg	09/24/10 02:57
1,1,1-Trichloroethane	< 0.040	0.040	mg/Kg	09/24/10 02:57
1,1-Dichloropropene	< 0.040	0.040	mg/Kg	09/24/10 02:57
1,2-Dichloroethane	< 0.040	0.040	mg/Kg	09/24/10 02:57
Carbon Tetrachloride	< 0.040	0.040	mg/Kg	09/24/10 02:57
Benzene	< 0.040	0.040	mg/Kg	09/24/10 02:57
Trichloroethene	0.72	0.040	mg/Kg	09/24/10 02:57
1,2-Dichloropropane	< 0.040	0.040	mg/Kg	09/24/10 02:57
Bromodichloromethane	< 0.040	0.040	mg/Kg	09/24/10 02:57
Dibromomethane	< 0.040	0.040	mg/Kg	09/24/10 02:57
cis-1,3-Dichloropropene	< 0.040	0.040	mg/Kg	09/24/10 02:57
Toluene	< 0.040	0.040	mg/Kg	09/24/10 02:57
trans-1,3-Dichloropropene	< 0.040	0.040	mg/Kg	09/24/10 02:57
1,1,2-Trichloroethane	< 0.040	0.040	mg/Kg	09/24/10 02:57
1,3-Dichloropropane	< 0.040	0.040	mg/Kg	09/24/10 02:57
Tetrachloroethene	34	0.40	mg/Kg	09/25/10 11:39
Dibromochloromethane	< 0.040	0.040	mg/Kg	09/24/10 02:57
1,2-Dibromoethane	< 0.040	0.040	mg/Kg	09/24/10 02:57
Chlorobenzene	< 0.040	0.040	mg/Kg	09/24/10 02:57
1,1,1,2-Tetrachloroethane	< 0.040	0.040	mg/Kg	09/24/10 02:57
Ethylbenzene	< 0.040	0.040	mg/Kg	09/24/10 02:57

Sample : **CB-3 (29)**

Project Name : **NuStar Vancouver Interim Action Confirmation Sampl**

Project Number : **E3WR-0028**

Lab Number : 74661-11

Matrix : Soil

Sample Date :09/21/2010

Analysis Method: EPA 8260B

Parameter	Measured Value	Method Reporting Limit	Units	Date/Time Analyzed
P,M-Xylene	< 0.040	0.040	mg/Kg	09/24/10 02:57
O-Xylene	< 0.040	0.040	mg/Kg	09/24/10 02:57
Styrene	< 0.040	0.040	mg/Kg	09/24/10 02:57
Isopropyl benzene	< 0.040	0.040	mg/Kg	09/24/10 02:57
Bromoform	< 0.040	0.040	mg/Kg	09/24/10 02:57
1,1,2,2-Tetrachloroethane	< 0.040	0.040	mg/Kg	09/24/10 02:57
1,2,3-Trichloropropane	< 0.040	0.040	mg/Kg	09/24/10 02:57
n-Propylbenzene	< 0.040	0.040	mg/Kg	09/24/10 02:57
Bromobenzene	< 0.040	0.040	mg/Kg	09/24/10 02:57
1,3,5-Trimethylbenzene	< 0.040	0.040	mg/Kg	09/24/10 02:57
2+4-Chlorotoluene	< 0.070	0.070	mg/Kg	09/24/10 02:57
tert-Butylbenzene	< 0.040	0.040	mg/Kg	09/24/10 02:57
1,2,4-Trimethylbenzene	< 0.040	0.040	mg/Kg	09/24/10 02:57
sec-Butylbenzene	< 0.040	0.040	mg/Kg	09/24/10 02:57
p-Isopropyltoluene	< 0.040	0.040	mg/Kg	09/24/10 02:57
1,3-Dichlorobenzene	< 0.040	0.040	mg/Kg	09/24/10 02:57
1,4-Dichlorobenzene	< 0.040	0.040	mg/Kg	09/24/10 02:57
n-Butylbenzene	< 0.040	0.040	mg/Kg	09/24/10 02:57
1,2-Dichlorobenzene	< 0.040	0.040	mg/Kg	09/24/10 02:57
1,2-Dibromo-3-chloropropane	< 0.040	0.040	mg/Kg	09/24/10 02:57
1,2,4-Trichlorobenzene	< 0.040	0.040	mg/Kg	09/24/10 02:57
Hexachlorobutadiene	< 0.040	0.040	mg/Kg	09/24/10 02:57
Naphthalene	< 0.040	0.040	mg/Kg	09/24/10 02:57
1,2,3-Trichlorobenzene	< 0.040	0.040	mg/Kg	09/24/10 02:57
1,2-Dichloroethane-d4 (Surr)	93.9		% Recovery	09/24/10 02:57
4-Bromofluorobenzene (Surr)	98.8		% Recovery	09/24/10 02:57
Toluene - d8 (Surr)	98.6		% Recovery	09/24/10 02:57

Sample : **CB-4 (18)**

Project Name : **NuStar Vancouver Interim Action Confirmation Sampl**

Project Number : **E3WR-0028**

Lab Number : 74661-12

Matrix : Soil

Sample Date :09/21/2010

Analysis Method: EPA 8260B

Parameter	Measured Value	Method Reporting Limit	Units	Date/Time Analyzed
Dichlorodifluoromethane	< 0.0050	0.0050	mg/Kg	09/25/10 02:26
Chloromethane	< 0.0050	0.0050	mg/Kg	09/25/10 02:26
Vinyl Chloride	< 0.0050	0.0050	mg/Kg	09/25/10 02:26
Bromomethane	< 0.020	0.020	mg/Kg	09/25/10 02:26
Chloroethane	< 0.0050	0.0050	mg/Kg	09/25/10 02:26
Trichlorofluoromethane	< 0.0050	0.0050	mg/Kg	09/25/10 02:26
1,1-Dichloroethene	< 0.0050	0.0050	mg/Kg	09/25/10 02:26
Methylene Chloride	< 0.0050	0.0050	mg/Kg	09/25/10 02:26
trans-1,2-Dichloroethene	< 0.0050	0.0050	mg/Kg	09/25/10 02:26
1,1-Dichloroethane	< 0.0050	0.0050	mg/Kg	09/25/10 02:26
2,2-Dichloropropane	< 0.0050	0.0050	mg/Kg	09/25/10 02:26
cis-1,2-Dichloroethene	< 0.0050	0.0050	mg/Kg	09/25/10 02:26
Chloroform	< 0.0050	0.0050	mg/Kg	09/25/10 02:26
Bromochloromethane	< 0.0050	0.0050	mg/Kg	09/25/10 02:26
1,1,1-Trichloroethane	< 0.0050	0.0050	mg/Kg	09/25/10 02:26
1,1-Dichloropropene	< 0.0050	0.0050	mg/Kg	09/25/10 02:26
1,2-Dichloroethane	< 0.0050	0.0050	mg/Kg	09/25/10 02:26
Carbon Tetrachloride	< 0.0050	0.0050	mg/Kg	09/25/10 02:26
Benzene	< 0.0050	0.0050	mg/Kg	09/25/10 02:26
Trichloroethene	< 0.0050	0.0050	mg/Kg	09/25/10 02:26
1,2-Dichloropropane	< 0.0050	0.0050	mg/Kg	09/25/10 02:26
Bromodichloromethane	< 0.0050	0.0050	mg/Kg	09/25/10 02:26
Dibromomethane	< 0.0050	0.0050	mg/Kg	09/25/10 02:26
cis-1,3-Dichloropropene	< 0.0050	0.0050	mg/Kg	09/25/10 02:26
Toluene	< 0.0050	0.0050	mg/Kg	09/25/10 02:26
trans-1,3-Dichloropropene	< 0.0050	0.0050	mg/Kg	09/25/10 02:26
1,1,2-Trichloroethane	< 0.0050	0.0050	mg/Kg	09/25/10 02:26
1,3-Dichloropropane	< 0.0050	0.0050	mg/Kg	09/25/10 02:26
Tetrachloroethene	2.0	0.025	mg/Kg	09/27/10 23:12
Dibromochloromethane	< 0.0050	0.0050	mg/Kg	09/25/10 02:26
1,2-Dibromoethane	< 0.0050	0.0050	mg/Kg	09/25/10 02:26
Chlorobenzene	< 0.0050	0.0050	mg/Kg	09/25/10 02:26
1,1,1,2-Tetrachloroethane	< 0.0050	0.0050	mg/Kg	09/25/10 02:26
Ethylbenzene	< 0.0050	0.0050	mg/Kg	09/25/10 02:26

Sample : **CB-4 (18)**

Project Name : **NuStar Vancouver Interim Action Confirmation Sampl**

Project Number : **E3WR-0028**

Lab Number : 74661-12

Matrix : Soil

Sample Date :09/21/2010

Analysis Method: EPA 8260B

Parameter	Measured Value	Method Reporting Limit	Units	Date/Time Analyzed
P,M-Xylene	< 0.0050	0.0050	mg/Kg	09/25/10 02:26
O-Xylene	< 0.0050	0.0050	mg/Kg	09/25/10 02:26
Styrene	< 0.0050	0.0050	mg/Kg	09/25/10 02:26
Isopropyl benzene	< 0.0050	0.0050	mg/Kg	09/25/10 02:26
Bromoform	< 0.0050	0.0050	mg/Kg	09/25/10 02:26
1,1,2,2-Tetrachloroethane	< 0.0050	0.0050	mg/Kg	09/25/10 02:26
1,2,3-Trichloropropane	< 0.0050	0.0050	mg/Kg	09/25/10 02:26
n-Propylbenzene	< 0.0050	0.0050	mg/Kg	09/25/10 02:26
Bromobenzene	< 0.0050	0.0050	mg/Kg	09/25/10 02:26
1,3,5-Trimethylbenzene	< 0.0050	0.0050	mg/Kg	09/25/10 02:26
2+4-Chlorotoluene	< 0.0050	0.0050	mg/Kg	09/25/10 02:26
tert-Butylbenzene	< 0.0050	0.0050	mg/Kg	09/25/10 02:26
1,2,4-Trimethylbenzene	< 0.0050	0.0050	mg/Kg	09/25/10 02:26
sec-Butylbenzene	< 0.0050	0.0050	mg/Kg	09/25/10 02:26
p-Isopropyltoluene	< 0.0050	0.0050	mg/Kg	09/25/10 02:26
1,3-Dichlorobenzene	< 0.0050	0.0050	mg/Kg	09/25/10 02:26
1,4-Dichlorobenzene	< 0.0050	0.0050	mg/Kg	09/25/10 02:26
n-Butylbenzene	< 0.0050	0.0050	mg/Kg	09/25/10 02:26
1,2-Dichlorobenzene	< 0.0050	0.0050	mg/Kg	09/25/10 02:26
1,2-Dibromo-3-chloropropane	< 0.0050	0.0050	mg/Kg	09/25/10 02:26
1,2,4-Trichlorobenzene	< 0.0050	0.0050	mg/Kg	09/25/10 02:26
Hexachlorobutadiene	< 0.0050	0.0050	mg/Kg	09/25/10 02:26
Naphthalene	< 0.0050	0.0050	mg/Kg	09/25/10 02:26
1,2,3-Trichlorobenzene	< 0.0050	0.0050	mg/Kg	09/25/10 02:26
1,2-Dichloroethane-d4 (Surr)	108		% Recovery	09/25/10 02:26
4-Bromofluorobenzene (Surr)	101		% Recovery	09/25/10 02:26
Toluene - d8 (Surr)	98.8		% Recovery	09/25/10 02:26

Sample : **CB-4 (28)**

Project Name : **NuStar Vancouver Interim Action Confirmation Sampl**

Project Number : **E3WR-0028**

Lab Number : 74661-13

Matrix : Soil

Sample Date :09/21/2010

Analysis Method: EPA 8260B

Parameter	Measured Value	Method Reporting Limit	Units	Date/Time Analyzed
Dichlorodifluoromethane	< 0.0050	0.0050	mg/Kg	09/24/10 17:24
Chloromethane	< 0.0050	0.0050	mg/Kg	09/24/10 17:24
Vinyl Chloride	< 0.0050	0.0050	mg/Kg	09/24/10 17:24
Bromomethane	< 0.020	0.020	mg/Kg	09/24/10 17:24
Chloroethane	< 0.0050	0.0050	mg/Kg	09/24/10 17:24
Trichlorofluoromethane	< 0.0050	0.0050	mg/Kg	09/24/10 17:24
1,1-Dichloroethene	< 0.0050	0.0050	mg/Kg	09/24/10 17:24
Methylene Chloride	< 0.0050	0.0050	mg/Kg	09/24/10 17:24
trans-1,2-Dichloroethene	< 0.0050	0.0050	mg/Kg	09/24/10 17:24
1,1-Dichloroethane	< 0.0050	0.0050	mg/Kg	09/24/10 17:24
2,2-Dichloropropane	< 0.0050	0.0050	mg/Kg	09/24/10 17:24
cis-1,2-Dichloroethene	< 0.0050	0.0050	mg/Kg	09/24/10 17:24
Chloroform	< 0.0050	0.0050	mg/Kg	09/24/10 17:24
Bromochloromethane	< 0.0050	0.0050	mg/Kg	09/24/10 17:24
1,1,1-Trichloroethane	< 0.0050	0.0050	mg/Kg	09/24/10 17:24
1,1-Dichloropropene	< 0.0050	0.0050	mg/Kg	09/24/10 17:24
1,2-Dichloroethane	< 0.0050	0.0050	mg/Kg	09/24/10 17:24
Carbon Tetrachloride	< 0.0050	0.0050	mg/Kg	09/24/10 17:24
Benzene	< 0.0050	0.0050	mg/Kg	09/24/10 17:24
Trichloroethene	< 0.0050	0.0050	mg/Kg	09/24/10 17:24
1,2-Dichloropropane	< 0.0050	0.0050	mg/Kg	09/24/10 17:24
Bromodichloromethane	< 0.0050	0.0050	mg/Kg	09/24/10 17:24
Dibromomethane	< 0.0050	0.0050	mg/Kg	09/24/10 17:24
cis-1,3-Dichloropropene	< 0.0050	0.0050	mg/Kg	09/24/10 17:24
Toluene	< 0.0050	0.0050	mg/Kg	09/24/10 17:24
trans-1,3-Dichloropropene	< 0.0050	0.0050	mg/Kg	09/24/10 17:24
1,1,2-Trichloroethane	< 0.0050	0.0050	mg/Kg	09/24/10 17:24
1,3-Dichloropropane	< 0.0050	0.0050	mg/Kg	09/24/10 17:24
Tetrachloroethene	0.080	0.0050	mg/Kg	09/24/10 17:24
Dibromochloromethane	< 0.0050	0.0050	mg/Kg	09/24/10 17:24
1,2-Dibromoethane	< 0.0050	0.0050	mg/Kg	09/24/10 17:24
Chlorobenzene	< 0.0050	0.0050	mg/Kg	09/24/10 17:24
1,1,1,2-Tetrachloroethane	< 0.0050	0.0050	mg/Kg	09/24/10 17:24
Ethylbenzene	< 0.0050	0.0050	mg/Kg	09/24/10 17:24

Sample : **CB-4 (28)**

Project Name : **NuStar Vancouver Interim Action Confirmation Sampl**

Project Number : **E3WR-0028**

Lab Number : 74661-13

Matrix : Soil

Sample Date :09/21/2010

Analysis Method: EPA 8260B

Parameter	Measured Value	Method Reporting Limit	Units	Date/Time Analyzed
P,M-Xylene	< 0.0050	0.0050	mg/Kg	09/24/10 17:24
O-Xylene	< 0.0050	0.0050	mg/Kg	09/24/10 17:24
Styrene	< 0.0050	0.0050	mg/Kg	09/24/10 17:24
Isopropyl benzene	< 0.0050	0.0050	mg/Kg	09/24/10 17:24
Bromoform	< 0.0050	0.0050	mg/Kg	09/24/10 17:24
1,1,2,2-Tetrachloroethane	< 0.0050	0.0050	mg/Kg	09/24/10 17:24
1,2,3-Trichloropropane	< 0.0050	0.0050	mg/Kg	09/24/10 17:24
n-Propylbenzene	< 0.0050	0.0050	mg/Kg	09/24/10 17:24
Bromobenzene	< 0.0050	0.0050	mg/Kg	09/24/10 17:24
1,3,5-Trimethylbenzene	< 0.0050	0.0050	mg/Kg	09/24/10 17:24
2+4-Chlorotoluene	< 0.0050	0.0050	mg/Kg	09/24/10 17:24
tert-Butylbenzene	< 0.0050	0.0050	mg/Kg	09/24/10 17:24
1,2,4-Trimethylbenzene	< 0.0050	0.0050	mg/Kg	09/24/10 17:24
sec-Butylbenzene	< 0.0050	0.0050	mg/Kg	09/24/10 17:24
p-Isopropyltoluene	< 0.0050	0.0050	mg/Kg	09/24/10 17:24
1,3-Dichlorobenzene	< 0.0050	0.0050	mg/Kg	09/24/10 17:24
1,4-Dichlorobenzene	< 0.0050	0.0050	mg/Kg	09/24/10 17:24
n-Butylbenzene	< 0.0050	0.0050	mg/Kg	09/24/10 17:24
1,2-Dichlorobenzene	< 0.0050	0.0050	mg/Kg	09/24/10 17:24
1,2-Dibromo-3-chloropropane	< 0.0050	0.0050	mg/Kg	09/24/10 17:24
1,2,4-Trichlorobenzene	< 0.0050	0.0050	mg/Kg	09/24/10 17:24
Hexachlorobutadiene	< 0.0050	0.0050	mg/Kg	09/24/10 17:24
Naphthalene	< 0.0050	0.0050	mg/Kg	09/24/10 17:24
1,2,3-Trichlorobenzene	< 0.0050	0.0050	mg/Kg	09/24/10 17:24
1,2-Dichloroethane-d4 (Surr)	109		% Recovery	09/24/10 17:24
4-Bromofluorobenzene (Surr)	101		% Recovery	09/24/10 17:24
Toluene - d8 (Surr)	99.8		% Recovery	09/24/10 17:24

Sample : **CB-4 (38.5)**

Project Name : **NuStar Vancouver Interim Action Confirmation Sampl**

Project Number : **E3WR-0028**

Lab Number : 74661-14

Matrix : Soil

Sample Date :09/21/2010

Analysis Method: EPA 8260B

Parameter	Measured Value	Method Reporting Limit	Units	Date/Time Analyzed
Dichlorodifluoromethane	< 0.040	0.040	mg/Kg	09/24/10 04:46
Chloromethane	< 0.040	0.040	mg/Kg	09/24/10 04:46
Vinyl Chloride	< 0.040	0.040	mg/Kg	09/24/10 04:46
Bromomethane	< 0.80	0.80	mg/Kg	09/24/10 04:46
Chloroethane	< 0.040	0.040	mg/Kg	09/24/10 04:46
Trichlorofluoromethane	< 0.040	0.040	mg/Kg	09/24/10 04:46
1,1-Dichloroethene	< 0.040	0.040	mg/Kg	09/24/10 04:46
Methylene Chloride	< 0.040	0.040	mg/Kg	09/24/10 04:46
trans-1,2-Dichloroethene	< 0.040	0.040	mg/Kg	09/24/10 04:46
1,1-Dichloroethane	< 0.040	0.040	mg/Kg	09/24/10 04:46
2,2-Dichloropropane	< 0.040	0.040	mg/Kg	09/24/10 04:46
cis-1,2-Dichloroethene	1.3	0.040	mg/Kg	09/24/10 04:46
Chloroform	< 0.040	0.040	mg/Kg	09/24/10 04:46
Bromochloromethane	< 0.040	0.040	mg/Kg	09/24/10 04:46
1,1,1-Trichloroethane	0.12	0.040	mg/Kg	09/24/10 04:46
1,1-Dichloropropene	< 0.040	0.040	mg/Kg	09/24/10 04:46
1,2-Dichloroethane	< 0.040	0.040	mg/Kg	09/24/10 04:46
Carbon Tetrachloride	< 0.040	0.040	mg/Kg	09/24/10 04:46
Benzene	< 0.040	0.040	mg/Kg	09/24/10 04:46
Trichloroethene	2.0	0.040	mg/Kg	09/24/10 04:46
1,2-Dichloropropane	< 0.040	0.040	mg/Kg	09/24/10 04:46
Bromodichloromethane	< 0.040	0.040	mg/Kg	09/24/10 04:46
Dibromomethane	< 0.040	0.040	mg/Kg	09/24/10 04:46
cis-1,3-Dichloropropene	< 0.040	0.040	mg/Kg	09/24/10 04:46
Toluene	< 0.040	0.040	mg/Kg	09/24/10 04:46
trans-1,3-Dichloropropene	< 0.040	0.040	mg/Kg	09/24/10 04:46
1,1,2-Trichloroethane	< 0.040	0.040	mg/Kg	09/24/10 04:46
1,3-Dichloropropane	< 0.040	0.040	mg/Kg	09/24/10 04:46
Tetrachloroethene	26	0.080	mg/Kg	09/28/10 10:36
Dibromochloromethane	< 0.040	0.040	mg/Kg	09/24/10 04:46
1,2-Dibromoethane	< 0.040	0.040	mg/Kg	09/24/10 04:46
Chlorobenzene	< 0.040	0.040	mg/Kg	09/24/10 04:46
1,1,1,2-Tetrachloroethane	< 0.040	0.040	mg/Kg	09/24/10 04:46
Ethylbenzene	< 0.040	0.040	mg/Kg	09/24/10 04:46

Sample : **CB-4 (38.5)**

Project Name : **NuStar Vancouver Interim Action Confirmation Sampl**

Project Number : **E3WR-0028**

Lab Number : 74661-14

Matrix : Soil

Sample Date :09/21/2010

Analysis Method: EPA 8260B

Parameter	Measured Value	Method Reporting Limit	Units	Date/Time Analyzed
P,M-Xylene	< 0.040	0.040	mg/Kg	09/24/10 04:46
O-Xylene	< 0.040	0.040	mg/Kg	09/24/10 04:46
Styrene	< 0.040	0.040	mg/Kg	09/24/10 04:46
Isopropyl benzene	< 0.040	0.040	mg/Kg	09/24/10 04:46
Bromoform	< 0.040	0.040	mg/Kg	09/24/10 04:46
1,1,2,2-Tetrachloroethane	< 0.040	0.040	mg/Kg	09/24/10 04:46
1,2,3-Trichloropropane	< 0.040	0.040	mg/Kg	09/24/10 04:46
n-Propylbenzene	< 0.040	0.040	mg/Kg	09/24/10 04:46
Bromobenzene	< 0.040	0.040	mg/Kg	09/24/10 04:46
1,3,5-Trimethylbenzene	< 0.040	0.040	mg/Kg	09/24/10 04:46
2+4-Chlorotoluene	< 0.080	0.080	mg/Kg	09/24/10 04:46
tert-Butylbenzene	< 0.040	0.040	mg/Kg	09/24/10 04:46
1,2,4-Trimethylbenzene	< 0.040	0.040	mg/Kg	09/24/10 04:46
sec-Butylbenzene	< 0.040	0.040	mg/Kg	09/24/10 04:46
p-Isopropyltoluene	< 0.040	0.040	mg/Kg	09/24/10 04:46
1,3-Dichlorobenzene	< 0.040	0.040	mg/Kg	09/24/10 04:46
1,4-Dichlorobenzene	< 0.040	0.040	mg/Kg	09/24/10 04:46
n-Butylbenzene	< 0.040	0.040	mg/Kg	09/24/10 04:46
1,2-Dichlorobenzene	< 0.040	0.040	mg/Kg	09/24/10 04:46
1,2-Dibromo-3-chloropropane	< 0.040	0.040	mg/Kg	09/24/10 04:46
1,2,4-Trichlorobenzene	< 0.040	0.040	mg/Kg	09/24/10 04:46
Hexachlorobutadiene	< 0.040	0.040	mg/Kg	09/24/10 04:46
Naphthalene	< 0.040	0.040	mg/Kg	09/24/10 04:46
1,2,3-Trichlorobenzene	< 0.040	0.040	mg/Kg	09/24/10 04:46
1,2-Dichloroethane-d4 (Surr)	97.3		% Recovery	09/24/10 04:46
4-Bromofluorobenzene (Surr)	99.1		% Recovery	09/24/10 04:46
Toluene - d8 (Surr)	99.1		% Recovery	09/24/10 04:46

QC Report : Method Blank Data

Project Name : **NuStar Vancouver Interim Action Confirmation Sampl**

Project Number : **E3WR-0028**

Parameter	Measured Value	Method Reporting Limit	Units	Analysis Method	Date Analyzed	Parameter	Measured Value	Method Reporting Limit	Units	Analysis Method	Date Analyzed
Dichlorodifluoromethane	< 0.0050	0.0050	mg/Kg	EPA 8260B	09/23/2010	Styrene	< 0.0050	0.0050	mg/Kg	EPA 8260B	09/23/2010
Chloromethane	< 0.0050	0.0050	mg/Kg	EPA 8260B	09/23/2010	Isopropyl benzene	< 0.0050	0.0050	mg/Kg	EPA 8260B	09/23/2010
Vinyl Chloride	< 0.0050	0.0050	mg/Kg	EPA 8260B	09/23/2010	Bromoform	< 0.0050	0.0050	mg/Kg	EPA 8260B	09/23/2010
Bromomethane	< 0.020	0.020	mg/Kg	EPA 8260B	09/23/2010	1,1,2,2-Tetrachloroethane	< 0.0050	0.0050	mg/Kg	EPA 8260B	09/23/2010
Chloroethane	< 0.0050	0.0050	mg/Kg	EPA 8260B	09/23/2010	1,2,3-Trichloropropane	< 0.0050	0.0050	mg/Kg	EPA 8260B	09/23/2010
Trichlorofluoromethane	< 0.0050	0.0050	mg/Kg	EPA 8260B	09/23/2010	n-Propylbenzene	< 0.0050	0.0050	mg/Kg	EPA 8260B	09/23/2010
1,1-Dichloroethene	< 0.0050	0.0050	mg/Kg	EPA 8260B	09/23/2010	Bromobenzene	< 0.0050	0.0050	mg/Kg	EPA 8260B	09/23/2010
Methylene Chloride	< 0.0050	0.0050	mg/Kg	EPA 8260B	09/23/2010	1,3,5-Trimethylbenzene	< 0.0050	0.0050	mg/Kg	EPA 8260B	09/23/2010
trans-1,2-Dichloroethene	< 0.0050	0.0050	mg/Kg	EPA 8260B	09/23/2010	2+4-Chlorotoluene	< 0.0050	0.0050	mg/Kg	EPA 8260B	09/23/2010
1,1-Dichloroethane	< 0.0050	0.0050	mg/Kg	EPA 8260B	09/23/2010	tert-Butylbenzene	< 0.0050	0.0050	mg/Kg	EPA 8260B	09/23/2010
2,2-Dichloropropane	< 0.0050	0.0050	mg/Kg	EPA 8260B	09/23/2010	1,2,4-Trimethylbenzene	< 0.0050	0.0050	mg/Kg	EPA 8260B	09/23/2010
cis-1,2-Dichloroethene	< 0.0050	0.0050	mg/Kg	EPA 8260B	09/23/2010	sec-Butylbenzene	< 0.0050	0.0050	mg/Kg	EPA 8260B	09/23/2010
Chloroform	< 0.0050	0.0050	mg/Kg	EPA 8260B	09/23/2010	p-Isopropyltoluene	< 0.0050	0.0050	mg/Kg	EPA 8260B	09/23/2010
Bromochloromethane	< 0.0050	0.0050	mg/Kg	EPA 8260B	09/23/2010	1,3-Dichlorobenzene	< 0.0050	0.0050	mg/Kg	EPA 8260B	09/23/2010
1,1,1-Trichloroethane	< 0.0050	0.0050	mg/Kg	EPA 8260B	09/23/2010	1,4-Dichlorobenzene	< 0.0050	0.0050	mg/Kg	EPA 8260B	09/23/2010
1,1-Dichloropropene	< 0.0050	0.0050	mg/Kg	EPA 8260B	09/23/2010	n-Butylbenzene	< 0.0050	0.0050	mg/Kg	EPA 8260B	09/23/2010
1,2-Dichloroethane	< 0.0050	0.0050	mg/Kg	EPA 8260B	09/23/2010	1,2-Dichlorobenzene	< 0.0050	0.0050	mg/Kg	EPA 8260B	09/23/2010
Carbon Tetrachloride	< 0.0050	0.0050	mg/Kg	EPA 8260B	09/23/2010	1,2-Dibromo-3-chloropropane	< 0.0050	0.0050	mg/Kg	EPA 8260B	09/23/2010
Benzene	< 0.0050	0.0050	mg/Kg	EPA 8260B	09/23/2010	1,2,4-Trichlorobenzene	< 0.0050	0.0050	mg/Kg	EPA 8260B	09/23/2010
Trichloroethene	< 0.0050	0.0050	mg/Kg	EPA 8260B	09/23/2010	Hexachlorobutadiene	< 0.0050	0.0050	mg/Kg	EPA 8260B	09/23/2010
1,2-Dichloropropane	< 0.0050	0.0050	mg/Kg	EPA 8260B	09/23/2010	Naphthalene	< 0.0050	0.0050	mg/Kg	EPA 8260B	09/23/2010
Bromodichloromethane	< 0.0050	0.0050	mg/Kg	EPA 8260B	09/23/2010	1,2,3-Trichlorobenzene	< 0.0050	0.0050	mg/Kg	EPA 8260B	09/23/2010
Dibromomethane	< 0.0050	0.0050	mg/Kg	EPA 8260B	09/23/2010	1,2-Dichloroethane-d4 (Surr)	105		%	EPA 8260B	09/23/2010
cis-1,3-Dichloropropene	< 0.0050	0.0050	mg/Kg	EPA 8260B	09/23/2010	4-Bromofluorobenzene (Surr)	100		%	EPA 8260B	09/23/2010
Toluene	< 0.0050	0.0050	mg/Kg	EPA 8260B	09/23/2010	Toluene - d8 (Surr)	99.1		%	EPA 8260B	09/23/2010
trans-1,3-Dichloropropene	< 0.0050	0.0050	mg/Kg	EPA 8260B	09/23/2010						
1,1,2-Trichloroethane	< 0.0050	0.0050	mg/Kg	EPA 8260B	09/23/2010						
1,3-Dichloropropane	< 0.0050	0.0050	mg/Kg	EPA 8260B	09/23/2010						
Dibromochloromethane	< 0.0050	0.0050	mg/Kg	EPA 8260B	09/23/2010						
1,2-Dibromoethane	< 0.0050	0.0050	mg/Kg	EPA 8260B	09/23/2010						
Chlorobenzene	< 0.0050	0.0050	mg/Kg	EPA 8260B	09/23/2010						
1,1,1,2-Tetrachloroethane	< 0.0050	0.0050	mg/Kg	EPA 8260B	09/23/2010						
Ethylbenzene	< 0.0050	0.0050	mg/Kg	EPA 8260B	09/23/2010						
P,M-Xylene	< 0.0050	0.0050	mg/Kg	EPA 8260B	09/23/2010						
O-Xylene	< 0.0050	0.0050	mg/Kg	EPA 8260B	09/23/2010						

QC Report : Method Blank Data

Project Name : NuStar Vancouver Interim Action Confirmation Sampl

Project Number : E3WR-0028

Parameter	Measured Value	Method Reporting Limit	Units	Analysis Method	Date Analyzed	Parameter	Measured Value	Method Reporting Limit	Units	Analysis Method	Date Analyzed
Dichlorodifluoromethane	< 0.0050	0.0050	mg/Kg	EPA 8260B	09/24/2010	O-Xylene	< 0.0050	0.0050	mg/Kg	EPA 8260B	09/24/2010
Chloromethane	< 0.0050	0.0050	mg/Kg	EPA 8260B	09/24/2010	Styrene	< 0.0050	0.0050	mg/Kg	EPA 8260B	09/24/2010
Vinyl Chloride	< 0.0050	0.0050	mg/Kg	EPA 8260B	09/24/2010	Isopropyl benzene	< 0.0050	0.0050	mg/Kg	EPA 8260B	09/24/2010
Bromomethane	< 0.020	0.020	mg/Kg	EPA 8260B	09/24/2010	Bromoform	< 0.0050	0.0050	mg/Kg	EPA 8260B	09/24/2010
Chloroethane	< 0.0050	0.0050	mg/Kg	EPA 8260B	09/24/2010	1,1,2,2-Tetrachloroethane	< 0.0050	0.0050	mg/Kg	EPA 8260B	09/24/2010
Trichlorofluoromethane	< 0.0050	0.0050	mg/Kg	EPA 8260B	09/24/2010	1,2,3-Trichloropropane	< 0.0050	0.0050	mg/Kg	EPA 8260B	09/24/2010
1,1-Dichloroethene	< 0.0050	0.0050	mg/Kg	EPA 8260B	09/24/2010	n-Propylbenzene	< 0.0050	0.0050	mg/Kg	EPA 8260B	09/24/2010
Methylene Chloride	< 0.0050	0.0050	mg/Kg	EPA 8260B	09/24/2010	Bromobenzene	< 0.0050	0.0050	mg/Kg	EPA 8260B	09/24/2010
trans-1,2-Dichloroethene	< 0.0050	0.0050	mg/Kg	EPA 8260B	09/24/2010	1,3,5-Trimethylbenzene	< 0.0050	0.0050	mg/Kg	EPA 8260B	09/24/2010
1,1-Dichloroethane	< 0.0050	0.0050	mg/Kg	EPA 8260B	09/24/2010	2+4-Chlorotoluene	< 0.0050	0.0050	mg/Kg	EPA 8260B	09/24/2010
2,2-Dichloropropane	< 0.0050	0.0050	mg/Kg	EPA 8260B	09/24/2010	tert-Butylbenzene	< 0.0050	0.0050	mg/Kg	EPA 8260B	09/24/2010
cis-1,2-Dichloroethene	< 0.0050	0.0050	mg/Kg	EPA 8260B	09/24/2010	1,2,4-Trimethylbenzene	< 0.0050	0.0050	mg/Kg	EPA 8260B	09/24/2010
Chloroform	< 0.0050	0.0050	mg/Kg	EPA 8260B	09/24/2010	sec-Butylbenzene	< 0.0050	0.0050	mg/Kg	EPA 8260B	09/24/2010
Bromochloromethane	< 0.0050	0.0050	mg/Kg	EPA 8260B	09/24/2010	p-Isopropyltoluene	< 0.0050	0.0050	mg/Kg	EPA 8260B	09/24/2010
1,1,1-Trichloroethane	< 0.0050	0.0050	mg/Kg	EPA 8260B	09/24/2010	1,3-Dichlorobenzene	< 0.0050	0.0050	mg/Kg	EPA 8260B	09/24/2010
1,1-Dichloropropene	< 0.0050	0.0050	mg/Kg	EPA 8260B	09/24/2010	1,4-Dichlorobenzene	< 0.0050	0.0050	mg/Kg	EPA 8260B	09/24/2010
1,2-Dichloroethane	< 0.0050	0.0050	mg/Kg	EPA 8260B	09/24/2010	n-Butylbenzene	< 0.0050	0.0050	mg/Kg	EPA 8260B	09/24/2010
Carbon Tetrachloride	< 0.0050	0.0050	mg/Kg	EPA 8260B	09/24/2010	1,2-Dichlorobenzene	< 0.0050	0.0050	mg/Kg	EPA 8260B	09/24/2010
Benzene	< 0.0050	0.0050	mg/Kg	EPA 8260B	09/24/2010	1,2-Dibromo-3-chloropropane	< 0.0050	0.0050	mg/Kg	EPA 8260B	09/24/2010
Trichloroethene	< 0.0050	0.0050	mg/Kg	EPA 8260B	09/24/2010	1,2,4-Trichlorobenzene	< 0.0050	0.0050	mg/Kg	EPA 8260B	09/24/2010
1,2-Dichloropropane	< 0.0050	0.0050	mg/Kg	EPA 8260B	09/24/2010	Hexachlorobutadiene	< 0.0050	0.0050	mg/Kg	EPA 8260B	09/24/2010
Bromodichloromethane	< 0.0050	0.0050	mg/Kg	EPA 8260B	09/24/2010	Naphthalene	< 0.0050	0.0050	mg/Kg	EPA 8260B	09/24/2010
Dibromomethane	< 0.0050	0.0050	mg/Kg	EPA 8260B	09/24/2010	1,2,3-Trichlorobenzene	< 0.0050	0.0050	mg/Kg	EPA 8260B	09/24/2010
cis-1,3-Dichloropropene	< 0.0050	0.0050	mg/Kg	EPA 8260B	09/24/2010	1,2-Dichloroethane-d4 (Surr)	102		%	EPA 8260B	09/24/2010
Toluene	< 0.0050	0.0050	mg/Kg	EPA 8260B	09/24/2010	4-Bromofluorobenzene (Surr)	97.2		%	EPA 8260B	09/24/2010
trans-1,3-Dichloropropene	< 0.0050	0.0050	mg/Kg	EPA 8260B	09/24/2010	Toluene - d8 (Surr)	99.0		%	EPA 8260B	09/24/2010
1,1,2-Trichloroethane	< 0.0050	0.0050	mg/Kg	EPA 8260B	09/24/2010						
1,3-Dichloropropane	< 0.0050	0.0050	mg/Kg	EPA 8260B	09/24/2010						
Tetrachloroethene	< 0.0050	0.0050	mg/Kg	EPA 8260B	09/24/2010						
Dibromochloromethane	< 0.0050	0.0050	mg/Kg	EPA 8260B	09/24/2010						
1,2-Dibromoethane	< 0.0050	0.0050	mg/Kg	EPA 8260B	09/24/2010						
Chlorobenzene	< 0.0050	0.0050	mg/Kg	EPA 8260B	09/24/2010						
1,1,1,2-Tetrachloroethane	< 0.0050	0.0050	mg/Kg	EPA 8260B	09/24/2010						
Ethylbenzene	< 0.0050	0.0050	mg/Kg	EPA 8260B	09/24/2010						
P,M-Xylene	< 0.0050	0.0050	mg/Kg	EPA 8260B	09/24/2010						

QC Report : Matrix Spike/ Matrix Spike Duplicate

Project Name : NuStar Vancouver Interim Action Confirmation Sampl

Project Number : E3WR-0028

Parameter	Spiked Sample	Sample Value	Spike Level	Spike Dup. Level	Spiked Sample Value	Duplicate Spiked Sample Value	Units	Analysis Method	Date Analyzed	Spiked Sample Percent Recov.	Duplicate Spiked Sample Percent Recov.	Relative Percent Diff.	Spiked Sample Percent Recov. Limit	Relative Percent Diff. Limit
1,1,1,2-Tetrachloroethane	74557-20	<0.0050	0.0399	0.0391	0.0357	0.0348	mg/Kg	EPA 8260B	9/23/10	89.4	88.9	0.534	70.0-130	25
1,1,1-Trichloroethane	74557-20	<0.0050	0.0399	0.0391	0.0360	0.0350	mg/Kg	EPA 8260B	9/23/10	90.3	89.5	0.913	70.0-130	25
1,1,2,2-Tetrachloroethane	74557-20	<0.0050	0.0399	0.0391	0.0369	0.0368	mg/Kg	EPA 8260B	9/23/10	92.5	94.2	1.80	60.7-133	25
1,1,2-Trichloroethane	74557-20	<0.0050	0.0399	0.0391	0.0347	0.0342	mg/Kg	EPA 8260B	9/23/10	86.9	87.5	0.698	70.0-130	25
1,1-Dichloroethane	74557-20	<0.0050	0.0399	0.0391	0.0349	0.0341	mg/Kg	EPA 8260B	9/23/10	87.5	87.1	0.460	66.1-120	25
1,1-Dichloroethene	74557-20	<0.0050	0.0399	0.0391	0.0335	0.0327	mg/Kg	EPA 8260B	9/23/10	83.9	83.4	0.514	65.9-122	25
1,1-Dichloropropene	74557-20	<0.0050	0.0399	0.0391	0.0347	0.0337	mg/Kg	EPA 8260B	9/23/10	87.0	86.1	1.12	70.0-130	25
1,2,3-Trichlorobenzene	74557-20	<0.0050	0.0399	0.0391	0.0235	0.0227	mg/Kg	EPA 8260B	9/23/10	58.8	57.9	1.44	70.0-130	25
1,2,3-Trichloropropane	74557-20	<0.0050	0.0399	0.0391	0.0354	0.0356	mg/Kg	EPA 8260B	9/23/10	88.6	91.0	2.68	70.0-130	25
1,2,4-Trichlorobenzene	74557-20	<0.0050	0.0399	0.0391	0.0232	0.0226	mg/Kg	EPA 8260B	9/23/10	58.1	57.8	0.616	70.0-130	25

QC Report : Matrix Spike/ Matrix Spike Duplicate

Project Name : NuStar Vancouver Interim Action Confirmation Sampl

Project Number : E3WR-0028

Parameter	Spiked Sample	Sample Value	Spike Level	Spike Dup. Level	Spiked Sample Value	Duplicate Spiked Sample Value	Units	Analysis Method	Date Analyzed	Spiked Sample Percent Recov.	Duplicate Spiked Sample Percent Recov.	Relative Percent Diff.	Spiked Sample Percent Recov. Limit	Relative Percent Diff. Limit
1,2,4-Trimethylbenzene	74557-20	<0.0050	0.0399	0.0391	0.0321	0.0314	mg/Kg	EPA 8260B	9/23/10	80.4	80.1	0.413	70.0-130	25
1,2-Dibromoethane	74557-20	<0.0050	0.0399	0.0391	0.0357	0.0351	mg/Kg	EPA 8260B	9/23/10	89.5	89.7	0.258	67.2-121	25
1,2-Dichlorobenzene	74557-20	<0.0050	0.0399	0.0391	0.0282	0.0275	mg/Kg	EPA 8260B	9/23/10	70.7	70.3	0.581	56.3-123	25
1,2-Dichloroethane	74557-20	<0.0050	0.0399	0.0391	0.0368	0.0359	mg/Kg	EPA 8260B	9/23/10	92.1	91.7	0.463	64.0-124	25
1,2-Dichloropropane	74557-20	<0.0050	0.0399	0.0391	0.0339	0.0334	mg/Kg	EPA 8260B	9/23/10	85.0	85.4	0.496	66.6-120	25
1,2-dibromo-3-chloropropane	74557-20	<0.0050	0.0399	0.0391	0.0329	0.0345	mg/Kg	EPA 8260B	9/23/10	82.5	88.0	6.48	59.4-138	25
1,3,5-Trimethylbenzene	74557-20	<0.0050	0.0399	0.0391	0.0322	0.0313	mg/Kg	EPA 8260B	9/23/10	80.6	80.0	0.793	70.0-130	25
1,3-Dichlorobenzene	74557-20	<0.0050	0.0399	0.0391	0.0299	0.0295	mg/Kg	EPA 8260B	9/23/10	74.8	75.3	0.605	52.5-132	25
1,3-Dichloropropane	74557-20	<0.0050	0.0399	0.0391	0.0349	0.0345	mg/Kg	EPA 8260B	9/23/10	87.4	88.1	0.742	70.0-130	25
1,4-Dichlorobenzene	74557-20	<0.0050	0.0399	0.0391	0.0281	0.0275	mg/Kg	EPA 8260B	9/23/10	70.4	70.2	0.281	57.0-123	25

QC Report : Matrix Spike/ Matrix Spike Duplicate

Project Name : NuStar Vancouver Interim Action Confirmation Sampl

Project Number : E3WR-0028

Parameter	Spiked Sample	Sample Value	Spike Level	Spike Dup. Level	Spiked Sample Value	Duplicate Spiked Sample Value	Units	Analysis Method	Date Analyzed	Spiked Sample Percent Recov.	Duplicate Spiked Sample Percent Recov.	Relative Percent Diff.	Spiked Sample Percent Recov. Limit	Relative Percent Diff. Limit
2+4-Chlorotoluene	74557-20	<0.0050	0.0798	0.0783	0.0611	0.0600	mg/Kg	EPA 8260B	9/23/10	76.5	76.6	0.107	70.0-130	25
2,2-Dichloropropane	74557-20	<0.0050	0.0399	0.0391	0.0357	0.0345	mg/Kg	EPA 8260B	9/23/10	89.5	88.1	1.58	70.0-130	25
Benzene	74557-20	<0.0050	0.0399	0.0391	0.0348	0.0341	mg/Kg	EPA 8260B	9/23/10	87.3	87.2	0.130	67.9-120	25
Bromobenzene	74557-20	<0.0050	0.0399	0.0391	0.0317	0.0312	mg/Kg	EPA 8260B	9/23/10	79.5	79.6	0.129	70.0-130	25
Bromochloromethane	74557-20	<0.0050	0.0399	0.0391	0.0353	0.0343	mg/Kg	EPA 8260B	9/23/10	88.5	87.7	0.871	70.0-130	25
Bromodichloromethane	74557-20	<0.0050	0.0399	0.0391	0.0359	0.0355	mg/Kg	EPA 8260B	9/23/10	90.0	90.8	0.932	70.0-130	25
Bromoform	74557-20	<0.0050	0.0399	0.0391	0.0371	0.0371	mg/Kg	EPA 8260B	9/23/10	92.8	94.9	2.18	58.2-146	25
Bromomethane	74557-20	<0.020	0.200	0.196	0.170	0.174	mg/Kg	EPA 8260B	9/23/10	85.0	89.2	4.81	45.5-139	25
Carbon Tetrachloride	74557-20	<0.0050	0.0399	0.0391	0.0364	0.0358	mg/Kg	EPA 8260B	9/23/10	91.2	91.5	0.418	70.0-130	25
Chlorobenzene	74557-20	<0.0050	0.0399	0.0391	0.0325	0.0318	mg/Kg	EPA 8260B	9/23/10	81.4	81.2	0.232	63.4-122	25

QC Report : Matrix Spike/ Matrix Spike Duplicate

Project Name : NuStar Vancouver Interim Action Confirmation Sampl

Project Number : E3WR-0028

Parameter	Spiked Sample	Sample Value	Spike Level	Spike Dup. Level	Spiked Sample Value	Duplicate Spiked Sample Value	Units	Analysis Method	Date Analyzed	Spiked Sample Percent Recov.	Duplicate Spiked Sample Percent Recov.	Relative Percent Diff.	Spiked Sample Percent Recov. Limit	Relative Percent Diff. Limit
Chloroethane	74557-20	<0.0050	0.0399	0.0391	0.0389	0.0379	mg/Kg	EPA 8260B	9/23/10	97.6	96.7	0.834	70.0-130	25
Chloroform	74557-20	<0.0050	0.0399	0.0391	0.0354	0.0346	mg/Kg	EPA 8260B	9/23/10	88.6	88.5	0.132	67.4-121	25
Chloromethane	74557-20	<0.0050	0.0399	0.0391	0.0354	0.0333	mg/Kg	EPA 8260B	9/23/10	88.7	85.0	4.26	47.9-127	25
Dibromochloromethane	74557-20	<0.0050	0.0399	0.0391	0.0362	0.0355	mg/Kg	EPA 8260B	9/23/10	90.6	90.8	0.196	70.0-130	25
Dibromomethane	74557-20	<0.0050	0.0399	0.0391	0.0368	0.0360	mg/Kg	EPA 8260B	9/23/10	92.1	92.0	0.152	70.0-130	25
Dichlorodifluoromethane	74557-20	<0.0050	0.0399	0.0391	0.0289	0.0283	mg/Kg	EPA 8260B	9/23/10	72.3	72.3	0.0443	40.5-144	25
Ethylbenzene	74557-20	<0.0050	0.0399	0.0391	0.0357	0.0349	mg/Kg	EPA 8260B	9/23/10	89.4	89.2	0.180	65.5-127	25
Hexachlorobutadiene	74557-20	<0.0050	0.0399	0.0391	0.0249	0.0249	mg/Kg	EPA 8260B	9/23/10	62.3	63.6	2.01	70.0-130	25
Isopropyl benzene	74557-20	<0.0050	0.0399	0.0391	0.0326	0.0320	mg/Kg	EPA 8260B	9/23/10	81.8	81.7	0.119	70.0-130	25
Methylene Chloride	74557-20	<0.0050	0.0399	0.0391	0.0340	0.0334	mg/Kg	EPA 8260B	9/23/10	85.2	85.2	0.0252	70.0-130	25

QC Report : Matrix Spike/ Matrix Spike Duplicate

Project Name : **NuStar Vancouver Interim Action Confirmation Sampl**Project Number : **E3WR-0028**

Parameter	Spiked Sample	Sample Value	Spike Level	Spike Dup. Level	Spiked Sample Value	Duplicate Spiked Sample Value	Units	Analysis Method	Date Analyzed	Spiked Sample Percent Recov.	Duplicate Spiked Sample Percent Recov.	Relative Percent Diff.	Spiked Sample Percent Recov. Limit	Relative Percent Diff. Limit
Naphthalene														
O-Xylene	74557-20	<0.0050	0.0399	0.0391	0.0247	0.0244	mg/Kg	EPA 8260B	9/23/10	61.9	62.4	0.903	70.0-130	25
P + M Xylene	74557-20	<0.0050	0.0399	0.0391	0.0346	0.0340	mg/Kg	EPA 8260B	9/23/10	86.6	86.8	0.238	62.3-124	25
Styrene	74557-20	<0.0050	0.0399	0.0391	0.0335	0.0330	mg/Kg	EPA 8260B	9/23/10	83.9	84.4	0.524	62.5-124	25
Toluene	74557-20	<0.0050	0.0399	0.0391	0.0322	0.0316	mg/Kg	EPA 8260B	9/23/10	80.8	80.8	0.0317	70.0-130	25
Trichloroethene	74557-20	<0.0050	0.0399	0.0391	0.0347	0.0340	mg/Kg	EPA 8260B	9/23/10	87.0	86.9	0.0929	65.7-120	25
Trichlorofluoromethane	74557-20	<0.0050	0.0399	0.0391	0.0320	0.0314	mg/Kg	EPA 8260B	9/23/10	80.2	80.4	0.215	63.9-121	25
Vinyl Chloride	74557-20	<0.0050	0.0399	0.0391	0.0340	0.0333	mg/Kg	EPA 8260B	9/23/10	85.2	85.2	0.0225	70.0-130	25
c-1,3-Dichloropropene	74557-20	<0.0050	0.0399	0.0391	0.0326	0.0318	mg/Kg	EPA 8260B	9/23/10	81.7	81.3	0.482	45.9-127	25
cis-1,2-Dichloroethene	74557-20	<0.0050	0.0399	0.0391	0.0342	0.0333	mg/Kg	EPA 8260B	9/23/10	85.6	85.2	0.529	70.0-130	25
	74557-20	<0.0050	0.0399	0.0391	0.0342	0.0336	mg/Kg	EPA 8260B	9/23/10	85.6	85.8	0.186	70.0-130	25

QC Report : Matrix Spike/ Matrix Spike Duplicate

Project Name : **NuStar Vancouver Interim Action Confirmation Sampl**Project Number : **E3WR-0028**

Parameter	Spiked Sample	Sample Value	Spike Level	Spike Dup. Level	Spiked Sample Value	Duplicate Spiked Sample Value	Units	Analysis Method	Date Analyzed	Spiked Sample Percent Recov.	Duplicate Spiked Sample Percent Recov.	Relative Percent Diff.	Spiked Sample Percent Recov. Limit	Relative Percent Diff. Limit
n-butylbenzene	74557-20	<0.0050	0.0399	0.0391	0.0280	0.0277	mg/Kg	EPA 8260B	9/23/10	70.2	70.9	0.974	70.0-130	25
n-propylbenzene	74557-20	<0.0050	0.0399	0.0391	0.0319	0.0308	mg/Kg	EPA 8260B	9/23/10	79.8	78.8	1.25	70.0-130	25
p-isopropyltoluene	74557-20	<0.0050	0.0399	0.0391	0.0313	0.0304	mg/Kg	EPA 8260B	9/23/10	78.3	77.6	0.947	70.0-130	25
sec-butylbenzene	74557-20	<0.0050	0.0399	0.0391	0.0317	0.0312	mg/Kg	EPA 8260B	9/23/10	79.3	79.7	0.503	70.0-130	25
t-1,2-Dichloroethene	74557-20	<0.0050	0.0399	0.0391	0.0338	0.0333	mg/Kg	EPA 8260B	9/23/10	84.6	85.2	0.684	70.0-130	25
t-1,3-Dichloropropene	74557-20	<0.0050	0.0399	0.0391	0.0350	0.0340	mg/Kg	EPA 8260B	9/23/10	87.6	86.8	0.846	70.0-130	25
tert-butylbenzene	74557-20	<0.0050	0.0399	0.0391	0.0320	0.0314	mg/Kg	EPA 8260B	9/23/10	80.1	80.2	0.0754	70.0-130	25
1,1,1,2-Tetrachloroethane														
	74557-07	<0.0050	0.0401	0.0394	0.0284	0.0265	mg/Kg	EPA 8260B	9/24/10	71.0	67.1	5.57	70.0-130	25
1,1,1-Trichloroethane	74557-07	<0.0050	0.0401	0.0394	0.0337	0.0322	mg/Kg	EPA 8260B	9/24/10	84.2	81.7	3.03	70.0-130	25

QC Report : Matrix Spike/ Matrix Spike Duplicate

Project Name : **NuStar Vancouver Interim Action Confirmation Sampl**Project Number : **E3WR-0028**

Parameter	Spiked Sample	Sample Value	Spike Level	Spike Dup. Level	Spiked Sample Value	Duplicate Spiked Sample Value	Units	Analysis Method	Date Analyzed	Spiked Sample Percent Recov.	Duplicate Spiked Sample Percent Recov.	Relative Percent Diff.	Spiked Sample Percent Recov. Limit	Relative Percent Diff. Limit
1,1,2,2-Tetrachloroethane														
	74557-07	<0.0050	0.0401	0.0394	0.0314	0.0295	mg/Kg	EPA 8260B	9/24/10	78.4	74.7	4.75	60.7-133	25
1,1,2-Trichloroethane														
	74557-07	<0.0050	0.0401	0.0394	0.0321	0.0302	mg/Kg	EPA 8260B	9/24/10	80.1	76.5	4.63	70.0-130	25
1,1-Dichloroethane														
	74557-07	<0.0050	0.0401	0.0394	0.0336	0.0315	mg/Kg	EPA 8260B	9/24/10	83.7	79.9	4.70	66.1-120	25
1,1-Dichloroethene														
	74557-07	<0.0050	0.0401	0.0394	0.0364	0.0345	mg/Kg	EPA 8260B	9/24/10	90.8	87.6	3.66	65.9-122	25
1,1-Dichloropropene														
	74557-07	<0.0050	0.0401	0.0394	0.0332	0.0317	mg/Kg	EPA 8260B	9/24/10	82.8	80.4	2.95	70.0-130	25
1,2,3-Trichlorobenzene														
	74557-07	<0.0050	0.0401	0.0394	0.0101	0.00884	mg/Kg	EPA 8260B	9/24/10	25.2	22.4	11.7	70.0-130	25
1,2,3-Trichloropropane														
	74557-07	<0.0050	0.0401	0.0394	0.0327	0.0311	mg/Kg	EPA 8260B	9/24/10	81.6	78.9	3.27	70.0-130	25
1,2,4-Trichlorobenzene														
	74557-07	<0.0050	0.0401	0.0394	0.0105	0.00920	mg/Kg	EPA 8260B	9/24/10	26.3	23.3	11.9	70.0-130	25
1,2,4-Trimethylbenzene														
	74557-07	<0.0050	0.0401	0.0394	0.0237	0.0223	mg/Kg	EPA 8260B	9/24/10	59.2	56.5	4.74	70.0-130	25
1,2-Dibromoethane														
	74557-07	<0.0050	0.0401	0.0394	0.0287	0.0274	mg/Kg	EPA 8260B	9/24/10	71.7	69.4	3.30	67.2-121	25

QC Report : Matrix Spike/ Matrix Spike DuplicateProject Name : **NuStar Vancouver Interim Action Confirmation Sampl**Project Number : **E3WR-0028**

Parameter	Spiked Sample	Sample Value	Spike Level	Spike Dup. Level	Spiked Sample Value	Duplicate Spiked Sample Value	Units	Analysis Method	Date Analyzed	Spiked Sample Percent Recov.	Duplicate Spiked Sample Percent Recov.	Relative Percent Diff.	Spiked Sample Percent Recov. Limit	Relative Percent Diff. Limit
1,2-Dichlorobenzene														
	74557-07	<0.0050	0.0401	0.0394	0.0172	0.0154	mg/Kg	EPA 8260B	9/24/10	43.0	39.0	9.72	56.3-123	25
1,2-Dichloroethane	74557-07	<0.0050	0.0401	0.0394	0.0325	0.0309	mg/Kg	EPA 8260B	9/24/10	81.1	78.4	3.48	64.0-124	25
1,2-Dichloropropane	74557-07	<0.0050	0.0401	0.0394	0.0318	0.0298	mg/Kg	EPA 8260B	9/24/10	79.3	75.6	4.77	66.6-120	25
1,2-dibromo-3-chloropropane	74557-07	<0.0050	0.0401	0.0394	0.0294	0.0279	mg/Kg	EPA 8260B	9/24/10	73.3	70.6	3.68	59.4-138	25
1,3,5-Trimethylbenzene														
	74557-07	<0.0050	0.0401	0.0394	0.0234	0.0220	mg/Kg	EPA 8260B	9/24/10	58.4	55.9	4.41	70.0-130	25
1,3-Dichlorobenzene														
	74557-07	<0.0050	0.0401	0.0394	0.0178	0.0166	mg/Kg	EPA 8260B	9/24/10	44.4	42.0	5.72	52.5-132	25
1,3-Dichloropropane	74557-07	<0.0050	0.0401	0.0394	0.0313	0.0297	mg/Kg	EPA 8260B	9/24/10	78.0	75.3	3.62	70.0-130	25
1,4-Dichlorobenzene														
	74557-07	<0.0050	0.0401	0.0394	0.0176	0.0156	mg/Kg	EPA 8260B	9/24/10	44.0	39.7	10.3	57.0-123	25
2+4-Chlorotoluene														
	74557-07	<0.0050	0.0802	0.0789	0.0426	0.0395	mg/Kg	EPA 8260B	9/24/10	53.1	50.1	5.85	70.0-130	25
2,2-Dichloropropane	74557-07	<0.0050	0.0401	0.0394	0.0336	0.0318	mg/Kg	EPA 8260B	9/24/10	83.8	80.7	3.72	70.0-130	25

QC Report : Matrix Spike/ Matrix Spike Duplicate

Project Name : **NuStar Vancouver Interim Action Confirmation Sampl**Project Number : **E3WR-0028**

Parameter	Spiked Sample	Sample Value	Spike Level	Spike Dup. Level	Spiked Sample Value	Duplicate Spiked Sample Value	Units	Analysis Method	Date Analyzed	Spiked Sample Percent Recov.	Duplicate Spiked Sample Percent Recov.	Relative Percent Diff.	Spiked Sample Percent Recov. Limit	Relative Percent Diff. Limit
Benzene	74557-07	<0.0050	0.0401	0.0394	0.0320	0.0301	mg/Kg	EPA 8260B	9/24/10	79.7	76.3	4.45	67.9-120	25
Bromobenzene	74557-07	<0.0050	0.0401	0.0394	0.0217	0.0203	mg/Kg	EPA 8260B	9/24/10	54.2	51.5	5.02	70.0-130	25
Bromochloromethane	74557-07	<0.0050	0.0401	0.0394	0.0323	0.0303	mg/Kg	EPA 8260B	9/24/10	80.7	76.8	4.90	70.0-130	25
Bromodichloromethane	74557-07	<0.0050	0.0401	0.0394	0.0306	0.0289	mg/Kg	EPA 8260B	9/24/10	76.5	73.3	4.18	70.0-130	25
Bromoform	74557-07	<0.0050	0.0401	0.0394	0.0311	0.0295	mg/Kg	EPA 8260B	9/24/10	77.5	74.7	3.64	58.2-146	25
Bromomethane	74557-07	<0.020	0.200	0.197	0.166	0.168	mg/Kg	EPA 8260B	9/24/10	82.8	85.0	2.58	45.5-139	25
Carbon Tetrachloride	74557-07	<0.0050	0.0401	0.0394	0.0337	0.0323	mg/Kg	EPA 8260B	9/24/10	84.1	81.9	2.66	70.0-130	25
Chlorobenzene	74557-07	<0.0050	0.0401	0.0394	0.0257	0.0241	mg/Kg	EPA 8260B	9/24/10	64.2	61.1	4.90	63.4-122	25
Chloroethane	74557-07	<0.0050	0.0401	0.0394	0.0344	0.0311	mg/Kg	EPA 8260B	9/24/10	85.9	78.8	8.53	70.0-130	25
Chloroform	74557-07	<0.0050	0.0401	0.0394	0.0318	0.0301	mg/Kg	EPA 8260B	9/24/10	79.5	76.2	4.18	67.4-121	25

QC Report : Matrix Spike/ Matrix Spike Duplicate

Project Name : **NuStar Vancouver Interim Action Confirmation Sampl**Project Number : **E3WR-0028**

Parameter	Spiked Sample	Sample Value	Spike Level	Spike Dup. Level	Spiked Sample Value	Duplicate Spiked Sample Value	Units	Analysis Method	Date Analyzed	Spiked Sample Percent Recov.	Duplicate Spiked Sample Percent Recov.	Relative Percent Diff.	Spiked Sample Percent Recov. Limit	Relative Percent Diff. Limit
Chloromethane	74557-07	<0.0050	0.0401	0.0394	0.0378	0.0351	mg/Kg	EPA 8260B	9/24/10	94.4	89.1	5.78	47.9-127	25
Dibromochloromethane	74557-07	<0.0050	0.0401	0.0394	0.0302	0.0283	mg/Kg	EPA 8260B	9/24/10	75.4	71.7	4.94	70.0-130	25
Dibromomethane	74557-07	<0.0050	0.0401	0.0394	0.0337	0.0314	mg/Kg	EPA 8260B	9/24/10	84.2	79.7	5.38	70.0-130	25
Dichlorodifluoromethane	74557-07	<0.0050	0.0401	0.0394	0.0325	0.0315	mg/Kg	EPA 8260B	9/24/10	81.0	79.8	1.50	40.5-144	25
Ethylbenzene	74557-07	<0.0050	0.0401	0.0394	0.0281	0.0267	mg/Kg	EPA 8260B	9/24/10	70.1	67.8	3.35	65.5-127	25
Hexachlorobutadiene	74557-07	<0.0050	0.0401	0.0394	0.0144	0.0130	mg/Kg	EPA 8260B	9/24/10	36.1	32.9	9.31	70.0-130	25
Isopropyl benzene	74557-07	<0.0050	0.0401	0.0394	0.0260	0.0246	mg/Kg	EPA 8260B	9/24/10	65.0	62.5	3.91	70.0-130	25
Methylene Chloride	74557-07	<0.0050	0.0401	0.0394	0.0338	0.0315	mg/Kg	EPA 8260B	9/24/10	84.4	79.8	5.61	70.0-130	25
Naphthalene	74557-07	<0.0050	0.0401	0.0394	0.0157	0.0144	mg/Kg	EPA 8260B	9/24/10	39.2	36.5	7.11	70.0-130	25
O-Xylene	74557-07	<0.0050	0.0401	0.0394	0.0267	0.0254	mg/Kg	EPA 8260B	9/24/10	66.6	64.3	3.54	62.3-124	25

QC Report : Matrix Spike/ Matrix Spike Duplicate

Project Name : **NuStar Vancouver Interim Action Confirmation Sampl**Project Number : **E3WR-0028**

Parameter	Spiked Sample	Sample Value	Spike Level	Spike Dup. Level	Spiked Sample Value	Duplicate Spiked Sample Value	Units	Analysis Method	Date Analyzed	Spiked Sample Percent Recov.	Duplicate Spiked Sample Percent Recov.	Relative Percent Diff.	Spiked Sample Percent Recov. Limit	Relative Percent Diff. Limit
P + M Xylene	74557-07	<0.0050	0.0401	0.0394	0.0274	0.0262	mg/Kg	EPA 8260B	9/24/10	68.3	66.4	2.77	62.5-124	25
Styrene	74557-07	<0.0050	0.0401	0.0394	0.0255	0.0237	mg/Kg	EPA 8260B	9/24/10	63.6	60.1	5.59	70.0-130	25
Tetrachloroethene	74557-07	0.0082	0.0401	0.0394	0.0396	0.0377	mg/Kg	EPA 8260B	9/24/10	78.4	74.8	4.78	64.7-122	25
Toluene	74557-07	<0.0050	0.0401	0.0394	0.0310	0.0290	mg/Kg	EPA 8260B	9/24/10	77.2	73.4	5.09	65.7-120	25
Trichloroethene	74557-07	<0.0050	0.0401	0.0394	0.0320	0.0301	mg/Kg	EPA 8260B	9/24/10	79.8	76.4	4.28	63.9-121	25
Trichlorofluoromethane	74557-07	<0.0050	0.0401	0.0394	0.0345	0.0330	mg/Kg	EPA 8260B	9/24/10	86.2	83.5	3.10	70.0-130	25
Vinyl Chloride	74557-07	<0.0050	0.0401	0.0394	0.0351	0.0338	mg/Kg	EPA 8260B	9/24/10	87.7	85.6	2.41	45.9-127	25
c-1,3-Dichloropropene	74557-07	<0.0050	0.0401	0.0394	0.0288	0.0266	mg/Kg	EPA 8260B	9/24/10	72.0	67.4	6.53	70.0-130	25
cis-1,2-Dichloroethene	74557-07	<0.0050	0.0401	0.0394	0.0329	0.0309	mg/Kg	EPA 8260B	9/24/10	82.2	78.3	4.77	70.0-130	25
n-butylbenzene	74557-07	<0.0050	0.0401	0.0394	0.0196	0.0181	mg/Kg	EPA 8260B	9/24/10	48.9	46.0	6.18	70.0-130	25

QC Report : Matrix Spike/ Matrix Spike Duplicate

Project Name : **NuStar Vancouver Interim Action Confirmation Sampl**

Project Number : **E3WR-0028**

Parameter	Spiked Sample	Sample Value	Spike Level	Spike Dup. Level	Spiked Sample Value	Duplicate Spiked Sample Value	Units	Analysis Method	Date Analyzed	Spiked Sample Percent Recov.	Duplicate Spiked Sample Percent Recov.	Relative Percent Diff.	Spiked Sample Percent Recov. Limit	Relative Percent Diff. Limit
n-propylbenzene	74557-07	<0.0050	0.0401	0.0394	0.0249	0.0238	mg/Kg	EPA 8260B	9/24/10	62.0	60.3	2.86	70.0-130	25
p-isopropyltoluene	74557-07	<0.0050	0.0401	0.0394	0.0220	0.0209	mg/Kg	EPA 8260B	9/24/10	55.0	52.9	3.74	70.0-130	25
sec-butylbenzene	74557-07	<0.0050	0.0401	0.0394	0.0235	0.0224	mg/Kg	EPA 8260B	9/24/10	58.6	56.9	2.88	70.0-130	25
t-1,2-Dichloroethene	74557-07	<0.0050	0.0401	0.0394	0.0346	0.0328	mg/Kg	EPA 8260B	9/24/10	86.3	83.2	3.68	70.0-130	25
t-1,3-Dichloropropene	74557-07	<0.0050	0.0401	0.0394	0.0294	0.0275	mg/Kg	EPA 8260B	9/24/10	73.3	69.7	5.02	70.0-130	25
tert-butylbenzene	74557-07	<0.0050	0.0401	0.0394	0.0241	0.0228	mg/Kg	EPA 8260B	9/24/10	60.1	57.8	3.89	70.0-130	25

QC Report : Laboratory Control Sample (LCS)Project Name : **NuStar Vancouver Interim Action Confirmation Sampl**Project Number : **E3WR-0028**

Parameter	Spike Level	Units	Analysis Method	Date Analyzed	LCS Percent Recov.	LCS Percent Recov. Limit
1,1,1,2-Tetrachloroethane	0.0391	mg/Kg	EPA 8260B	9/23/10	97.3	70.0-130
1,1,1-Trichloroethane	0.0391	mg/Kg	EPA 8260B	9/23/10	94.0	70.0-130
1,1,2,2-Tetrachloroethane	0.0391	mg/Kg	EPA 8260B	9/23/10	105	60.7-133
1,1,2-Trichloroethane	0.0391	mg/Kg	EPA 8260B	9/23/10	94.7	70.0-130
1,1-Dichloroethane	0.0391	mg/Kg	EPA 8260B	9/23/10	91.0	66.1-120
1,1-Dichloroethene	0.0391	mg/Kg	EPA 8260B	9/23/10	86.6	65.9-122
1,1-Dichloropropene	0.0391	mg/Kg	EPA 8260B	9/23/10	91.0	70.0-130
1,2,3-Trichlorobenzene	0.0391	mg/Kg	EPA 8260B	9/23/10	90.3	70.0-130
1,2,3-Trichloropropane	0.0391	mg/Kg	EPA 8260B	9/23/10	98.8	70.0-130
1,2,4-Trichlorobenzene	0.0391	mg/Kg	EPA 8260B	9/23/10	88.6	70.0-130
1,2,4-Trimethylbenzene	0.0391	mg/Kg	EPA 8260B	9/23/10	94.7	70.0-130
1,2-Dibromoethane	0.0391	mg/Kg	EPA 8260B	9/23/10	98.5	67.2-121
1,2-Dichlorobenzene	0.0391	mg/Kg	EPA 8260B	9/23/10	90.6	56.3-123
1,2-Dichloroethane	0.0391	mg/Kg	EPA 8260B	9/23/10	99.9	64.0-124
1,2-Dichloropropane	0.0391	mg/Kg	EPA 8260B	9/23/10	90.9	66.6-120
1,2-dibromo-3-chloropropane	0.0391	mg/Kg	EPA 8260B	9/23/10	99.8	59.4-138
1,3,5-Trimethylbenzene	0.0391	mg/Kg	EPA 8260B	9/23/10	92.1	70.0-130
1,3-Dichlorobenzene	0.0391	mg/Kg	EPA 8260B	9/23/10	94.7	52.5-132
1,3-Dichloropropane	0.0391	mg/Kg	EPA 8260B	9/23/10	95.7	70.0-130
1,4-Dichlorobenzene	0.0391	mg/Kg	EPA 8260B	9/23/10	89.4	57.0-123
2+4-Chlorotoluene	0.0783	mg/Kg	EPA 8260B	9/23/10	91.9	70.0-130
2,2-Dichloropropane	0.0391	mg/Kg	EPA 8260B	9/23/10	94.7	70.0-130
Benzene	0.0391	mg/Kg	EPA 8260B	9/23/10	92.8	67.9-120

QC Report : Laboratory Control Sample (LCS)Project Name : **NuStar Vancouver Interim Action Confirmation Sampl**Project Number : **E3WR-0028**

Parameter	Spike Level	Units	Analysis Method	Date Analyzed	LCS Percent Recov.	LCS Percent Recov. Limit
Bromobenzene	0.0391	mg/Kg	EPA 8260B	9/23/10	94.2	70.0-130
Bromochloromethane	0.0391	mg/Kg	EPA 8260B	9/23/10	93.7	70.0-130
Bromodichloromethane	0.0391	mg/Kg	EPA 8260B	9/23/10	96.5	70.0-130
Bromoform	0.0391	mg/Kg	EPA 8260B	9/23/10	104	58.2-146
Bromomethane	0.196	mg/Kg	EPA 8260B	9/23/10	83.8	45.5-139
Carbon Tetrachloride	0.0391	mg/Kg	EPA 8260B	9/23/10	96.3	70.0-130
Chlorobenzene	0.0391	mg/Kg	EPA 8260B	9/23/10	91.7	63.4-122
Chloroethane	0.0391	mg/Kg	EPA 8260B	9/23/10	100	70.0-130
Chloroform	0.0391	mg/Kg	EPA 8260B	9/23/10	93.6	67.4-121
Chloromethane	0.0391	mg/Kg	EPA 8260B	9/23/10	95.2	47.9-127
Dibromochloromethane	0.0391	mg/Kg	EPA 8260B	9/23/10	99.5	70.0-130
Dibromomethane	0.0391	mg/Kg	EPA 8260B	9/23/10	100	70.0-130
Dichlorodifluoromethane	0.0391	mg/Kg	EPA 8260B	9/23/10	74.3	40.5-144
Ethylbenzene	0.0391	mg/Kg	EPA 8260B	9/23/10	98.0	65.5-127
Hexachlorobutadiene	0.0391	mg/Kg	EPA 8260B	9/23/10	90.0	70.0-130
Isopropyl benzene	0.0391	mg/Kg	EPA 8260B	9/23/10	92.2	70.0-130
Methylene Chloride	0.0391	mg/Kg	EPA 8260B	9/23/10	90.4	70.0-130
Naphthalene	0.0391	mg/Kg	EPA 8260B	9/23/10	93.5	70.0-130
O-Xylene	0.0391	mg/Kg	EPA 8260B	9/23/10	95.9	62.3-124
P + M Xylene	0.0391	mg/Kg	EPA 8260B	9/23/10	94.2	62.5-124
Styrene	0.0391	mg/Kg	EPA 8260B	9/23/10	95.9	70.0-130
Toluene	0.0391	mg/Kg	EPA 8260B	9/23/10	93.8	65.7-120
Trichloroethene	0.0391	mg/Kg	EPA 8260B	9/23/10	86.4	63.9-121

QC Report : Laboratory Control Sample (LCS)Project Name : **NuStar Vancouver Interim Action Confirmation Sampl**Project Number : **E3WR-0028**

Parameter	Spike Level	Units	Analysis Method	Date Analyzed	LCS Percent Recov.	LCS Percent Recov. Limit
Trichlorofluoromethane	0.0391	mg/Kg	EPA 8260B	9/23/10	89.4	70.0-130
Vinyl Chloride	0.0391	mg/Kg	EPA 8260B	9/23/10	84.3	45.9-127
c-1,3-Dichloropropene	0.0391	mg/Kg	EPA 8260B	9/23/10	93.8	70.0-130
cis-1,2-Dichloroethene	0.0391	mg/Kg	EPA 8260B	9/23/10	92.1	70.0-130
n-butylbenzene	0.0391	mg/Kg	EPA 8260B	9/23/10	89.6	70.0-130
n-propylbenzene	0.0391	mg/Kg	EPA 8260B	9/23/10	91.5	70.0-130
p-isopropyltoluene	0.0391	mg/Kg	EPA 8260B	9/23/10	92.6	70.0-130
sec-butylbenzene	0.0391	mg/Kg	EPA 8260B	9/23/10	93.8	70.0-130
t-1,2-Dichloroethene	0.0391	mg/Kg	EPA 8260B	9/23/10	89.1	70.0-130
t-1,3-Dichloropropene	0.0391	mg/Kg	EPA 8260B	9/23/10	97.0	70.0-130
tert-butylbenzene	0.0391	mg/Kg	EPA 8260B	9/23/10	92.5	70.0-130
1,1,1,2-Tetrachloroethane	0.0400	mg/Kg	EPA 8260B	9/24/10	95.0	70.0-130
1,1,1-Trichloroethane	0.0400	mg/Kg	EPA 8260B	9/24/10	91.3	70.0-130
1,1,2,2-Tetrachloroethane	0.0400	mg/Kg	EPA 8260B	9/24/10	103	60.7-133
1,1,2-Trichloroethane	0.0400	mg/Kg	EPA 8260B	9/24/10	96.0	70.0-130
1,1-Dichloroethane	0.0400	mg/Kg	EPA 8260B	9/24/10	91.3	66.1-120
1,1-Dichloroethene	0.0400	mg/Kg	EPA 8260B	9/24/10	94.2	65.9-122
1,1-Dichloropropene	0.0400	mg/Kg	EPA 8260B	9/24/10	90.5	70.0-130
1,2,3-Trichlorobenzene	0.0400	mg/Kg	EPA 8260B	9/24/10	89.1	70.0-130
1,2,3-Trichloropropane	0.0400	mg/Kg	EPA 8260B	9/24/10	98.8	70.0-130
1,2,4-Trichlorobenzene	0.0400	mg/Kg	EPA 8260B	9/24/10	88.0	70.0-130
1,2,4-Trimethylbenzene	0.0400	mg/Kg	EPA 8260B	9/24/10	95.2	70.0-130

QC Report : Laboratory Control Sample (LCS)Project Name : **NuStar Vancouver Interim Action Confirmation Sampl**Project Number : **E3WR-0028**

Parameter	Spike Level	Units	Analysis Method	Date Analyzed	LCS Percent Recov.	LCS Percent Recov. Limit
1,2-Dibromoethane	0.0400	mg/Kg	EPA 8260B	9/24/10	87.4	67.2-121
1,2-Dichlorobenzene	0.0400	mg/Kg	EPA 8260B	9/24/10	90.7	56.3-123
1,2-Dichloroethane	0.0400	mg/Kg	EPA 8260B	9/24/10	91.8	64.0-124
1,2-Dichloropropane	0.0400	mg/Kg	EPA 8260B	9/24/10	92.6	66.6-120
1,2-dibromo-3-chloropropane	0.0400	mg/Kg	EPA 8260B	9/24/10	100	59.4-138
1,3,5-Trimethylbenzene	0.0400	mg/Kg	EPA 8260B	9/24/10	94.9	70.0-130
1,3-Dichlorobenzene	0.0400	mg/Kg	EPA 8260B	9/24/10	95.0	52.5-132
1,3-Dichloropropane	0.0400	mg/Kg	EPA 8260B	9/24/10	93.4	70.0-130
1,4-Dichlorobenzene	0.0400	mg/Kg	EPA 8260B	9/24/10	88.0	57.0-123
2+4-Chlorotoluene	0.0800	mg/Kg	EPA 8260B	9/24/10	93.8	70.0-130
2,2-Dichloropropane	0.0400	mg/Kg	EPA 8260B	9/24/10	88.9	70.0-130
Benzene	0.0400	mg/Kg	EPA 8260B	9/24/10	91.6	67.9-120
Bromobenzene	0.0400	mg/Kg	EPA 8260B	9/24/10	91.2	70.0-130
Bromochloromethane	0.0400	mg/Kg	EPA 8260B	9/24/10	92.2	70.0-130
Bromodichloromethane	0.0400	mg/Kg	EPA 8260B	9/24/10	92.7	70.0-130
Bromoform	0.0400	mg/Kg	EPA 8260B	9/24/10	102	58.2-146
Bromomethane	0.200	mg/Kg	EPA 8260B	9/24/10	83.0	45.5-139
Carbon Tetrachloride	0.0400	mg/Kg	EPA 8260B	9/24/10	91.4	70.0-130
Chlorobenzene	0.0400	mg/Kg	EPA 8260B	9/24/10	92.1	63.4-122
Chloroethane	0.0400	mg/Kg	EPA 8260B	9/24/10	87.7	70.0-130
Chloroform	0.0400	mg/Kg	EPA 8260B	9/24/10	90.6	67.4-121
Chloromethane	0.0400	mg/Kg	EPA 8260B	9/24/10	96.0	47.9-127
Dibromochloromethane	0.0400	mg/Kg	EPA 8260B	9/24/10	94.2	70.0-130

QC Report : Laboratory Control Sample (LCS)Project Name : **NuStar Vancouver Interim Action Confirmation Sampl**Project Number : **E3WR-0028**

Parameter	Spike Level	Units	Analysis Method	Date Analyzed	LCS Percent Recov.	LCS Percent Recov. Limit
Dibromomethane	0.0400	mg/Kg	EPA 8260B	9/24/10	95.2	70.0-130
Dichlorodifluoromethane	0.0400	mg/Kg	EPA 8260B	9/24/10	78.1	40.5-144
Ethylbenzene	0.0400	mg/Kg	EPA 8260B	9/24/10	94.9	65.5-127
Hexachlorobutadiene	0.0400	mg/Kg	EPA 8260B	9/24/10	91.7	70.0-130
Isopropyl benzene	0.0400	mg/Kg	EPA 8260B	9/24/10	93.6	70.0-130
Methylene Chloride	0.0400	mg/Kg	EPA 8260B	9/24/10	92.4	70.0-130
Naphthalene	0.0400	mg/Kg	EPA 8260B	9/24/10	97.7	70.0-130
O-Xylene	0.0400	mg/Kg	EPA 8260B	9/24/10	94.5	62.3-124
P + M Xylene	0.0400	mg/Kg	EPA 8260B	9/24/10	95.2	62.5-124
Styrene	0.0400	mg/Kg	EPA 8260B	9/24/10	101	70.0-130
Tetrachloroethene	0.0400	mg/Kg	EPA 8260B	9/24/10	93.7	64.7-122
Toluene	0.0400	mg/Kg	EPA 8260B	9/24/10	91.9	65.7-120
Trichloroethene	0.0400	mg/Kg	EPA 8260B	9/24/10	92.0	63.9-121
Trichlorofluoromethane	0.0400	mg/Kg	EPA 8260B	9/24/10	85.4	70.0-130
Vinyl Chloride	0.0400	mg/Kg	EPA 8260B	9/24/10	87.0	45.9-127
c-1,3-Dichloropropene	0.0400	mg/Kg	EPA 8260B	9/24/10	89.1	70.0-130
cis-1,2-Dichloroethene	0.0400	mg/Kg	EPA 8260B	9/24/10	91.4	70.0-130
n-butylbenzene	0.0400	mg/Kg	EPA 8260B	9/24/10	94.2	70.0-130
n-propylbenzene	0.0400	mg/Kg	EPA 8260B	9/24/10	97.9	70.0-130
p-isopropyltoluene	0.0400	mg/Kg	EPA 8260B	9/24/10	97.8	70.0-130
sec-butylbenzene	0.0400	mg/Kg	EPA 8260B	9/24/10	96.3	70.0-130
t-1,2-Dichloroethene	0.0400	mg/Kg	EPA 8260B	9/24/10	93.4	70.0-130
t-1,3-Dichloropropene	0.0400	mg/Kg	EPA 8260B	9/24/10	92.0	70.0-130

QC Report : Laboratory Control Sample (LCS)

Project Name : **NuStar Vancouver Interim Action Confirmation Sampl**

Project Number : **E3WR-0028**

Parameter	Spike Level	Units	Analysis Method	Date Analyzed	LCS Percent Recov.	LCS Percent Recov. Limit
tert-butylbenzene	0.0400	mg/Kg	EPA 8260B	9/24/10	94.3	70.0-130

Project Contact (Hardcopy or PDF To): Stephanie Bosze
 Company / Address: Ash Creek Associates
 Phone Number: 503-894-4704 x125
 Fax Number:
 Project #: 1126-09 P.O. #:
 Project Name: Nustar Vancouver
 Interim Action Confirmation Sampler Adam Reese

California EDF Report? Yes No
 Sampling Company Log Code:
 Global ID:
 EDF Deliverable To (Email Address): sbosze@ashcreekassociates.com
 Bill to: Nustar
 Sampler Signature: Stephanie Bosze

Chain-of-Custody Record and Analysis Request

Project Address:	Sampling		Container and Preservative							Matrix					
	Date	Time	40 mL HCl VOA	250 mL HNO ₃ HDPE	250 mL H ₂ SO ₄ HDPE	1 L H ₂ SO ₄ amber	125 mL ZnAc ₂ & NaOH	250 mL unpres HDPE	40 mL HCl VOA (RSK)	HNO ₃	None VOA	None VOA	Water	Soil	Air
CB-3(25)	9/2/10	1545	3										X		
CB-3(29)	9/2/10	1540	3							2	1		X		
CB-4(18)	9/2/10	1030	3							2	1		X		
CB-4(28)	9/2/10	1045	3							2	1		X		
CB-4(38.S)	9/2/10	1300	?							2	1		X		

Analysis Request												TAT
												<input type="checkbox"/> 12 hr
												<input type="checkbox"/> 24 hr
												<input type="checkbox"/> 48 hr
												<input type="checkbox"/> 72 hr
												<input type="checkbox"/> 1 wk

For Lab Use Only

Relinquished by: Stephanie Bosze Date: 9/22/10 Time: 1150
 Received by: _____
 Relinquished by: _____ Date: _____ Time: _____
 Received by: _____
 Relinquished by: _____ Date: _____ Time: _____
 Received by Laboratory: Michelle Spencer

Remarks: * Soil jars (for dry weight) submitted in separate cooler on 9/2/10

For Lab Use Only: Sample Receipt					
Temp °C	Initials	Date	Time	Therm. ID #	Coolant Present
					Yes / No

SAMPLE RECEIPT CHECKLIST

RECEIVER
MAS
Initials

SRG#: 746661 Date: 092310

Project ID: NuStar Vancouver Interim Action Confirmation Sampling

Method of Receipt: Courier Over-the-counter Shipper

COC Inspection

Is COC present? Yes No
 Custody seals on shipping container? Intact Broken Not present N/A
 Is COC Signed by Relinquisher? Yes No Dated? Yes No
 Is sampler name legibly indicated on COC? Yes No
 Is analysis or hold requested for all samples Yes No
 Is the turnaround time indicated on COC? Yes No
 Is COC free of whiteout and uninitialed cross-outs? Yes No, Whiteout No, Cross-outs

Sample Inspection

Coolant Present: Yes No (includes water)
 Temperature °C 5.2 Therm. ID# IR-5 Initial MAS Date/Time 092310/1116 N/A
 Are there custody seals on sample containers? Intact Broken Not present
 Do containers match COC? Yes No No, COC lists absent sample(s) No, Extra sample(s) present
 Are there samples matrices other than soil, water, air or carbon? Yes No
 Are any sample containers broken, leaking or damaged? Yes No
 Are preservatives indicated? Yes, on sample containers Yes, on COC Not indicated N/A
 Are preservatives correct for analyses requested? Yes No N/A
 Are samples within holding time for analyses requested? Yes No
 Are the correct sample containers used for the analyses requested? Yes No
 Is there sufficient sample to perform testing? Yes No
 Does any sample contain product, have strong odor or are otherwise suspected to be hot? Yes No

Receipt Details

Matrix SD Container type VOA # of containers received 42
 Matrix _____ Container type _____ # of containers received _____
 Matrix _____ Container type _____ # of containers received _____
 Date and Time Sample Put into Temp Storage Date: 092310 Time: 1200

Quicklog

Are the Sample ID's indicated: On COC On sample container(s) On Both Not indicated
 If Sample ID's are listed on both COC and containers, do they all match? Yes No N/A
 Is the Project ID indicated: On COC On sample container(s) On Both Not indicated
 If project ID is listed on both COC and containers, do they all match? Yes No N/A
 Are the sample collection dates indicated: On COC On sample container(s) On Both Not indicated
 If collection dates are listed on both COC and containers, do they all match? Yes No N/A
 Are the sample collection times indicated: On COC On sample container(s) On Both Not indicated
 If collection times are listed on both COC and containers, do they all match? Yes No N/A

COMMENTS: No TAT. Sample ⁻⁰⁵ labels say CB2 (9.5). Date & Time
on labels for -08 say 0830 on 092110. For target sample -07
the label on glass jar says 1500 - the lid and VOAs say
1100 which ^{MAS} matches COC. For -03 all VOAs appear to
be Methamid preserved. MAS 092310 1226



Laboratory Results

Stephanie Bosze
Ash Creek Assoc.
3015 SW First Avenue
Portland, OR 97201-4707

Subject : 1 Water Sample
Project Name : Vancouver IA Confirmation Sampling
Project Number : E3WR-0028
P.O. Number : 4501259182-20

Dear Ms. Bosze,

Chemical analysis of the samples referenced above has been completed. Summaries of the data are contained on the following pages. Sample(s) were received under documented chain-of-custody. US EPA protocols for sample storage and preservation were followed. Testing procedures comply with the 2003 NELAC standard. All soil samples are reported on a total weight (wet weight) basis unless noted otherwise in the case narrative. Laboratory results relate only to the samples tested. This report may be freely reproduced in full, but may only be reproduced in part with the express permission of Kiff Analytical, LLC. Kiff Analytical, LLC is certified by the State of California under the National Environmental Laboratory Accreditation Program (NELAP), lab # 08263CA. If you have any questions regarding procedures or results, please call me at 530-297-4800.

Sincerely,



Joel Kiff

Sample : CB-3(45)

Project Name : Vancouver IA Confirmation Sampling

Project Number : E3WR-0028

Lab Number : 74657-01

Matrix : Water

Sample Date :09/21/2010

Analysis Method: EPA 8260B

Parameter	Measured Value	Method Reporting Limit	Units	Date/Time Analyzed
Chloromethane	< 3.0	3.0	ug/L	09/24/10 10:54
Vinyl Chloride	26	3.0	ug/L	09/24/10 10:54
Bromomethane	< 60	60	ug/L	09/24/10 10:54
Chloroethane	< 3.0	3.0	ug/L	09/24/10 10:54
Trichlorofluoromethane	< 3.0	3.0	ug/L	09/24/10 10:54
1,1-Dichloroethene	4.5	3.0	ug/L	09/24/10 10:54
Methylene Chloride	< 5.0	5.0	ug/L	09/24/10 10:54
trans-1,2-Dichloroethene	5.8	3.0	ug/L	09/24/10 10:54
1,1-Dichloroethane	28	3.0	ug/L	09/24/10 10:54
cis-1,2-Dichloroethene	280	3.0	ug/L	09/24/10 10:54
Chloroform	< 3.0	3.0	ug/L	09/24/10 10:54
1,1,1-Trichloroethane	11	3.0	ug/L	09/24/10 10:54
1,2-Dichloroethane	< 3.0	3.0	ug/L	09/24/10 10:54
Carbon Tetrachloride	< 3.0	3.0	ug/L	09/24/10 10:54
Trichloroethene	270	3.0	ug/L	09/24/10 10:54
1,2-Dichloropropane	< 3.0	3.0	ug/L	09/24/10 10:54
Bromodichloromethane	< 3.0	3.0	ug/L	09/24/10 10:54
cis-1,3-Dichloropropene	< 3.0	3.0	ug/L	09/24/10 10:54
trans-1,3-Dichloropropene	< 3.0	3.0	ug/L	09/24/10 10:54
1,1,2-Trichloroethane	< 3.0	3.0	ug/L	09/24/10 10:54
Tetrachloroethene	690	3.0	ug/L	09/24/10 10:54
Dibromochloromethane	< 3.0	3.0	ug/L	09/24/10 10:54
1,2-Dibromoethane	< 3.0	3.0	ug/L	09/24/10 10:54
Chlorobenzene	< 3.0	3.0	ug/L	09/24/10 10:54
Bromoform	< 3.0	3.0	ug/L	09/24/10 10:54
1,1,2,2-Tetrachloroethane	< 3.0	3.0	ug/L	09/24/10 10:54
1,3-Dichlorobenzene	< 3.0	3.0	ug/L	09/24/10 10:54
1,4-Dichlorobenzene	< 3.0	3.0	ug/L	09/24/10 10:54
1,2-Dichlorobenzene	< 3.0	3.0	ug/L	09/24/10 10:54
1,2-Dichloroethane-d4 (Surr)	103		% Recovery	09/24/10 10:54
4-Bromofluorobenzene (Surr)	101		% Recovery	09/24/10 10:54
Toluene - d8 (Surr)	100		% Recovery	09/24/10 10:54

QC Report : Method Blank DataProject Name : **Vancouver IA Confirmation Sampling**Project Number : **E3WR-0028**

Parameter	Measured Value	Method Reporting Limit	Units	Analysis Method	Date Analyzed
1,1,1-Trichloroethane	< 0.50	0.50	ug/L	EPA 8260B	09/24/2010
1,1,2,2-Tetrachloroethane	< 0.50	0.50	ug/L	EPA 8260B	09/24/2010
1,1,2-Trichloroethane	< 0.50	0.50	ug/L	EPA 8260B	09/24/2010
1,1-Dichloroethane	< 0.50	0.50	ug/L	EPA 8260B	09/24/2010
1,1-Dichloroethene	< 0.50	0.50	ug/L	EPA 8260B	09/24/2010
1,2-Dibromoethane	< 0.50	0.50	ug/L	EPA 8260B	09/24/2010
1,2-Dichlorobenzene	< 0.50	0.50	ug/L	EPA 8260B	09/24/2010
1,2-Dichloroethane	< 0.50	0.50	ug/L	EPA 8260B	09/24/2010
1,2-Dichloropropane	< 0.50	0.50	ug/L	EPA 8260B	09/24/2010
1,3-Dichlorobenzene	< 0.50	0.50	ug/L	EPA 8260B	09/24/2010
1,4-Dichlorobenzene	< 0.50	0.50	ug/L	EPA 8260B	09/24/2010
Bromodichloromethane	< 0.50	0.50	ug/L	EPA 8260B	09/24/2010
Bromoform	< 0.50	0.50	ug/L	EPA 8260B	09/24/2010
Bromomethane	< 20	20	ug/L	EPA 8260B	09/24/2010
Carbon Tetrachloride	< 0.50	0.50	ug/L	EPA 8260B	09/24/2010
Chlorobenzene	< 0.50	0.50	ug/L	EPA 8260B	09/24/2010
Chloroethane	< 0.50	0.50	ug/L	EPA 8260B	09/24/2010
Chloroform	< 0.50	0.50	ug/L	EPA 8260B	09/24/2010
Chloromethane	< 0.50	0.50	ug/L	EPA 8260B	09/24/2010
Dibromochloromethane	< 0.50	0.50	ug/L	EPA 8260B	09/24/2010
Methylene Chloride	< 5.0	5.0	ug/L	EPA 8260B	09/24/2010
Tetrachloroethene	< 0.50	0.50	ug/L	EPA 8260B	09/24/2010
Trichloroethene	< 0.50	0.50	ug/L	EPA 8260B	09/24/2010
Trichlorofluoromethane	< 0.50	0.50	ug/L	EPA 8260B	09/24/2010
Vinyl Chloride	< 0.50	0.50	ug/L	EPA 8260B	09/24/2010
cis-1,2-Dichloroethene	< 0.50	0.50	ug/L	EPA 8260B	09/24/2010
cis-1,3-Dichloropropene	< 0.50	0.50	ug/L	EPA 8260B	09/24/2010
trans-1,2-Dichloroethene	< 0.50	0.50	ug/L	EPA 8260B	09/24/2010
trans-1,3-Dichloropropene	< 0.50	0.50	ug/L	EPA 8260B	09/24/2010
1,2-Dichloroethane-d4 (Surr)	101		%	EPA 8260B	09/24/2010
4-Bromofluorobenzene (Surr)	98.9		%	EPA 8260B	09/24/2010
Toluene - d8 (Surr)	99.9		%	EPA 8260B	09/24/2010

Parameter	Measured Value	Method Reporting Limit	Units	Analysis Method	Date Analyzed
-----------	----------------	------------------------	-------	-----------------	---------------

QC Report : Matrix Spike/ Matrix Spike Duplicate

Project Name : **Vancouver IA Confirmation Sampling**Project Number : **E3WR-0028**

Parameter	Spiked Sample	Sample Value	Spike Level	Spike Dup. Level	Spiked Sample Value	Duplicate Spiked Sample Value	Units	Analysis Method	Date Analyzed	Spiked Sample Percent Recov.	Duplicate Spiked Sample Percent Recov.	Relative Percent Diff.	Spiked Sample Percent Recov. Limit	Relative Percent Diff. Limit
1,1,1-Trichloroethane	74665-01	<0.50	39.9	40.0	41.0	39.9	ug/L	EPA 8260B	9/24/10	102	99.7	2.87	70.0-130	25
1,1,2,2-Tetrachloroethane	74665-01	<0.50	39.9	40.0	41.0	40.6	ug/L	EPA 8260B	9/24/10	103	101	1.23	80-121	25
1,1,2-Trichloroethane	74665-01	<0.50	39.9	40.0	38.4	38.0	ug/L	EPA 8260B	9/24/10	96.1	95.0	1.21	70.0-130	25
1,1-Dichloroethane	74665-01	<0.50	39.9	40.0	39.2	38.5	ug/L	EPA 8260B	9/24/10	98.1	96.3	1.90	76.5-120	25
1,1-Dichloroethene	74665-01	<0.50	39.9	40.0	37.8	36.6	ug/L	EPA 8260B	9/24/10	94.6	91.4	3.49	69.6-124	25
1,2-Dibromoethane	74665-01	<0.50	39.9	40.0	39.3	38.8	ug/L	EPA 8260B	9/24/10	98.4	96.9	1.61	80-120	25
1,2-Dichlorobenzene	74665-01	<0.50	39.9	40.0	37.8	37.5	ug/L	EPA 8260B	9/24/10	94.8	93.7	1.07	80-120	25
1,2-Dichloroethane	74665-01	<0.50	39.9	40.0	41.0	40.3	ug/L	EPA 8260B	9/24/10	103	101	2.00	75.7-122	25
1,2-Dichloropropane	74665-01	<0.50	39.9	40.0	38.0	37.8	ug/L	EPA 8260B	9/24/10	95.2	94.6	0.646	80-120	25
1,3-Dichlorobenzene	74665-01	<0.50	39.9	40.0	39.8	39.4	ug/L	EPA 8260B	9/24/10	99.6	98.5	1.15	79.3-120	25

QC Report : Matrix Spike/ Matrix Spike DuplicateProject Name : **Vancouver IA Confirmation Sampling**Project Number : **E3WR-0028**

Parameter	Spiked Sample	Sample Value	Spike Level	Spike Dup. Level	Spiked Sample Value	Duplicate Spiked Sample Value	Units	Analysis Method	Date Analyzed	Spiked Sample Percent Recov.	Duplicate Spiked Sample Percent Recov.	Relative Percent Diff.	Spiked Sample Percent Recov. Limit	Relative Percent Diff. Limit
1,4-Dichlorobenzene	74665-01	<0.50	39.9	40.0	37.5	37.1	ug/L	EPA 8260B	9/24/10	93.9	92.8	1.18	80-120	25
Bromodichloromethane	74665-01	<0.50	39.9	40.0	40.7	40.3	ug/L	EPA 8260B	9/24/10	102	101	1.23	70.0-130	25
Bromoform	74665-01	<0.50	39.9	40.0	42.2	41.1	ug/L	EPA 8260B	9/24/10	106	103	3.04	73.0-142	25
Bromomethane	74665-01	<20	200	200	182	197	ug/L	EPA 8260B	9/24/10	91.1	98.4	7.70	33.5-140	25
Carbon Tetrachloride	74665-01	<0.50	39.9	40.0	42.0	40.7	ug/L	EPA 8260B	9/24/10	105	102	3.46	70.0-130	25
Chlorobenzene	74665-01	<0.50	39.9	40.0	38.9	38.5	ug/L	EPA 8260B	9/24/10	97.3	96.3	1.04	80-120	25
Chloroethane	74665-01	<0.50	39.9	40.0	43.3	42.4	ug/L	EPA 8260B	9/24/10	108	106	2.24	70.0-130	25
Chloroform	74665-01	<0.50	39.9	40.0	40.2	39.6	ug/L	EPA 8260B	9/24/10	100	98.9	1.69	80.0-120	25
Chloromethane	74665-01	<0.50	39.9	40.0	39.5	37.3	ug/L	EPA 8260B	9/24/10	99.0	93.3	5.91	45.9-142	25
Dibromochloromethane	74665-01	<0.50	39.9	40.0	40.8	40.6	ug/L	EPA 8260B	9/24/10	102	102	0.747	70.0-130	25

QC Report : Matrix Spike/ Matrix Spike Duplicate

Project Name : **Vancouver IA Confirmation Sampling**Project Number : **E3WR-0028**

Parameter	Spiked Sample	Sample Value	Spike Level	Spike Dup. Level	Spiked Sample Value	Duplicate Spiked Sample Value	Units	Analysis Method	Date Analyzed	Spiked Sample Percent Recov.	Duplicate Spiked Sample Percent Recov.	Relative Percent Diff.	Spiked Sample Percent Recov. Limit	Relative Percent Diff. Limit
Methylene Chloride	74665-01	<5.0	39.9	40.0	38.0	37.6	ug/L	EPA 8260B	9/24/10	95.1	93.9	1.22	70.0-130	25
Tetrachloroethene	74665-01	<0.50	39.9	40.0	38.8	38.4	ug/L	EPA 8260B	9/24/10	97.1	96.0	1.16	77.0-120	25
Trichloroethene	74665-01	<0.50	39.9	40.0	37.0	36.2	ug/L	EPA 8260B	9/24/10	92.8	90.6	2.38	80-120	25
Trichlorofluoromethane	74665-01	<0.50	39.9	40.0	38.9	37.6	ug/L	EPA 8260B	9/24/10	97.5	93.9	3.75	70.0-130	25
Vinyl Chloride	74665-01	<0.50	39.9	40.0	37.0	35.6	ug/L	EPA 8260B	9/24/10	92.6	88.9	4.04	42.1-138	25
c-1,3-Dichloropropene	74665-01	<5.0	39.9	40.0	38.4	37.8	ug/L	EPA 8260B	9/24/10	96.2	94.6	1.73	70.0-130	25
cis-1,2-Dichloroethene	74665-01	<0.50	39.9	40.0	38.8	38.3	ug/L	EPA 8260B	9/24/10	97.1	95.8	1.38	70.0-130	25
t-1,2-Dichloroethene	74665-01	<5.0	39.9	40.0	38.0	36.9	ug/L	EPA 8260B	9/24/10	95.2	92.3	3.12	70.0-130	25
t-1,3-Dichloropropene	74665-01	<5.0	39.9	40.0	38.5	38.3	ug/L	EPA 8260B	9/24/10	96.3	95.7	0.661	70.0-130	25

QC Report : Laboratory Control Sample (LCS)Project Name : **Vancouver IA Confirmation Sampling**Project Number : **E3WR-0028**

Parameter	Spike Level	Units	Analysis Method	Date Analyzed	LCS Percent Recov.	LCS Percent Recov. Limit
1,1,1-Trichloroethane	40.0	ug/L	EPA 8260B	9/24/10	102	70.0-130
1,1,2,2-Tetrachloroethane	40.0	ug/L	EPA 8260B	9/24/10	97.8	80-121
1,1,2-Trichloroethane	40.0	ug/L	EPA 8260B	9/24/10	94.5	70.0-130
1,1-Dichloroethane	40.0	ug/L	EPA 8260B	9/24/10	96.8	76.5-120
1,1-Dichloroethene	40.0	ug/L	EPA 8260B	9/24/10	93.8	69.6-124
1,2-Dibromoethane	40.0	ug/L	EPA 8260B	9/24/10	98.2	80-120
1,2-Dichlorobenzene	40.0	ug/L	EPA 8260B	9/24/10	94.0	80-120
1,2-Dichloroethane	40.0	ug/L	EPA 8260B	9/24/10	102	75.7-122
1,2-Dichloropropane	40.0	ug/L	EPA 8260B	9/24/10	94.2	80-120
1,3-Dichlorobenzene	40.0	ug/L	EPA 8260B	9/24/10	99.0	79.3-120
1,4-Dichlorobenzene	40.0	ug/L	EPA 8260B	9/24/10	94.2	80-120
Bromodichloromethane	40.0	ug/L	EPA 8260B	9/24/10	102	70.0-130
Bromoform	40.0	ug/L	EPA 8260B	9/24/10	105	73.0-142
Bromomethane	200	ug/L	EPA 8260B	9/24/10	98.2	33.5-140
Carbon Tetrachloride	40.0	ug/L	EPA 8260B	9/24/10	104	70.0-130
Chlorobenzene	40.0	ug/L	EPA 8260B	9/24/10	97.2	80-120
Chloroethane	40.0	ug/L	EPA 8260B	9/24/10	108	70.0-130
Chloroform	40.0	ug/L	EPA 8260B	9/24/10	99.8	80.0-120
Chloromethane	40.0	ug/L	EPA 8260B	9/24/10	102	45.9-142
Dibromochloromethane	40.0	ug/L	EPA 8260B	9/24/10	101	70.0-130
Methylene Chloride	40.0	ug/L	EPA 8260B	9/24/10	94.9	70.0-130
Tetrachloroethene	40.0	ug/L	EPA 8260B	9/24/10	98.1	77.0-120
Trichloroethene	40.0	ug/L	EPA 8260B	9/24/10	95.0	80-120

QC Report : Laboratory Control Sample (LCS)Project Name : **Vancouver IA Confirmation Sampling**Project Number : **E3WR-0028**

Parameter	Spike Level	Units	Analysis Method	Date Analyzed	LCS Percent Recov.	LCS Percent Recov. Limit
Trichlorofluoromethane	40.0	ug/L	EPA 8260B	9/24/10	97.3	70.0-130
Vinyl Chloride	40.0	ug/L	EPA 8260B	9/24/10	93.1	42.1-138
c-1,3-Dichloropropene	40.0	ug/L	EPA 8260B	9/24/10	95.5	70.0-130
cis-1,2-Dichloroethene	40.0	ug/L	EPA 8260B	9/24/10	96.9	70.0-130
t-1,2-Dichloroethene	40.0	ug/L	EPA 8260B	9/24/10	95.2	70.0-130
t-1,3-Dichloropropene	40.0	ug/L	EPA 8260B	9/24/10	96.7	70.0-130

SAMPLE RECEIPT CHECKLIST

RECEIVER
Eos
Initials

SRG#: 74657 Date: 092310
Project ID: Vancouver IA Confirmation Sampling
Method of Receipt: Courier Over-the-counter Shipper

COC Inspection

Is COC present? Yes No
 Custody seals on shipping container? Intact Broken Not present N/A
 Is COC Signed by Relinquisher? Yes No Dated? Yes No
 Is sampler name legibly indicated on COC? Yes No
 Is analysis or hold requested for all samples? Yes No
 Is the turnaround time indicated on COC? Yes No
 Is COC free of whiteout and uninitialed cross-outs? Yes No, Whiteout No, Cross-outs

Sample Inspection

Coolant Present: Yes No (includes water)
 Temperature °C 6.4 Therm. ID# IR-5 Initial Eos Date/Time 092310 1030 N/A
 Are there custody seals on sample containers? Intact Broken Not present
 Do containers match COC? Yes No No, COC lists absent sample(s) No, Extra sample(s) present
 Are there samples matrices other than soil, water, air or carbon? Yes No
 Are any sample containers broken, leaking or damaged? Yes No
 Are preservatives indicated? Yes, on sample containers Yes, on COC Not indicated N/A
 Are preservatives correct for analyses requested? Yes No N/A
 Are samples within holding time for analyses requested? Yes No
 Are the correct sample containers used for the analyses requested? Yes No
 Is there sufficient sample to perform testing? Yes No
 Does any sample contain product, have strong odor or are otherwise suspected to be hot? Yes No

Receipt Details
 Matrix WA Container type Vox # of containers received 3
 Matrix _____ Container type _____ # of containers received _____
 Matrix _____ Container type _____ # of containers received _____
 Date and Time Sample Put into Temp Storage Date: 092310 Time: 1038

Quicklog

Are the Sample ID's indicated: On COC On sample container(s) On Both Not indicated
 If Sample ID's are listed on both COC and containers, do they all match? Yes No N/A
 Is the Project ID indicated: On COC On sample container(s) On Both Not indicated
 If project ID is listed on both COC and containers, do they all match? Yes No N/A
 Are the sample collection dates indicated: On COC On sample container(s) On Both Not indicated
 If collection dates are listed on both COC and containers, do they all match? Yes No N/A
 Are the sample collection times indicated: On COC On sample container(s) On Both Not indicated
 If collection times are listed on both COC and containers, do they all match? Yes No N/A

COMMENTS: No TAT. Temperature exceptions. Eos 092310 1038
Logged project name per COC but container labels have
"VANCOUVER." Eos 092310 1119

Appendix B

Soil Vapor Extraction Design

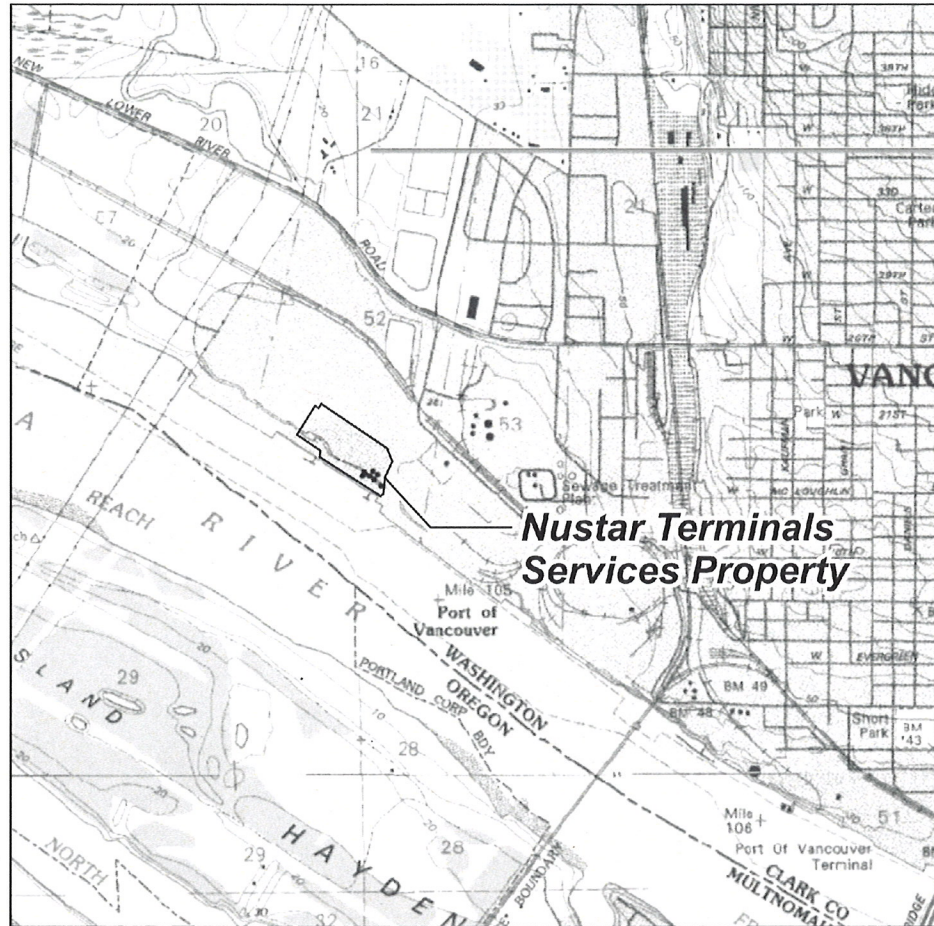

DRAWING SET:

- B-1 DRAWING SET AND LEGEND
- B-2 SITE PLAN
- B-3 SVE SYSTEM LAYOUT
- B-4 DETAILS
- B-5 VAPOR FLOW SCHEMATIC
- B-6 SPECIFICATIONS

LEGEND:

- VE-1-2** 2008 INTERIM ACTION VAPOR EXTRACTION WELL LOCATION
- EX-3** EARLY 2000s INTERIM ACTION GROUNDWATER EXTRACTION WELL
- IN-1** EARLY 2000s INTERIM ACTION GROUNDWATER INJECTION WELL AND VAPOR EXTRACTION WELL
- MW-1** GROUNDWATER MONITORING WELL
- MGMS3** MULTI-LEVEL GROUNDWATER WELL
- GATE VALVE
- FLOW METER
- PRESSURE GAUGE
- SAMPLE PORT
- LOGIC CONTROL
- CATCH BASIN
- BUILDING
- FENCE
- ELECTRICAL
- SYSTEM ELECTRICAL
- STORM SEWER
- WATER
- MANHOLE
- RAILROAD TRACKS
-
- VE-1-2** PROPOSED 2010 EXPANDED INTERIM ACTION WELL LOCATION AND VAULT
-
-



WASHINGTON

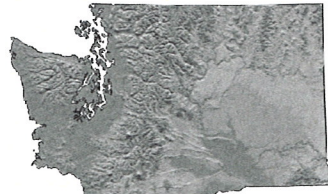

VANCOUVER



SOURCES:

1. BASE PLAN PREPARED FROM AN AUTOCAD FILE (SECOR FIGURE 1, JOB 150T.STSRV.05.0012).
2. UTILITY LOCATIONS SHOWN BASED ON SURFACE MARKINGS BY UTILITY LOCATOR.



DESIGNED: MWS
 DRAWN: JLP
 CHECKED: HFC
 CHECKED: MWS
 APPROVED: MWS

EXTERNAL REFERENCE FILES
 UPDATED XREF Base 1126.DWG

SUBMITTED: Michael Stevens
 ASSOCIATE ENGINEER

DATE: 11/1/2010

ZONE		REV.	DESCRIPTION	BY	DATE	APP.

DRAWING SET AND LEGEND

2010 INTERIM ACTION WORK PLAN IMPLEMENTATION
 NUSTAR TERMINALS SERVICES, INC. VANCOUVER FACILITY
 VANCOUVER, WASHINGTON

FILENAME	1126-09 (DRAWING SET 1)
AC PROJECT NUMBER	1126-09
SCALE	NOT TO SCALE
DRAWING NUMBER	B-1
SHEET NUMBER	1 OF 6

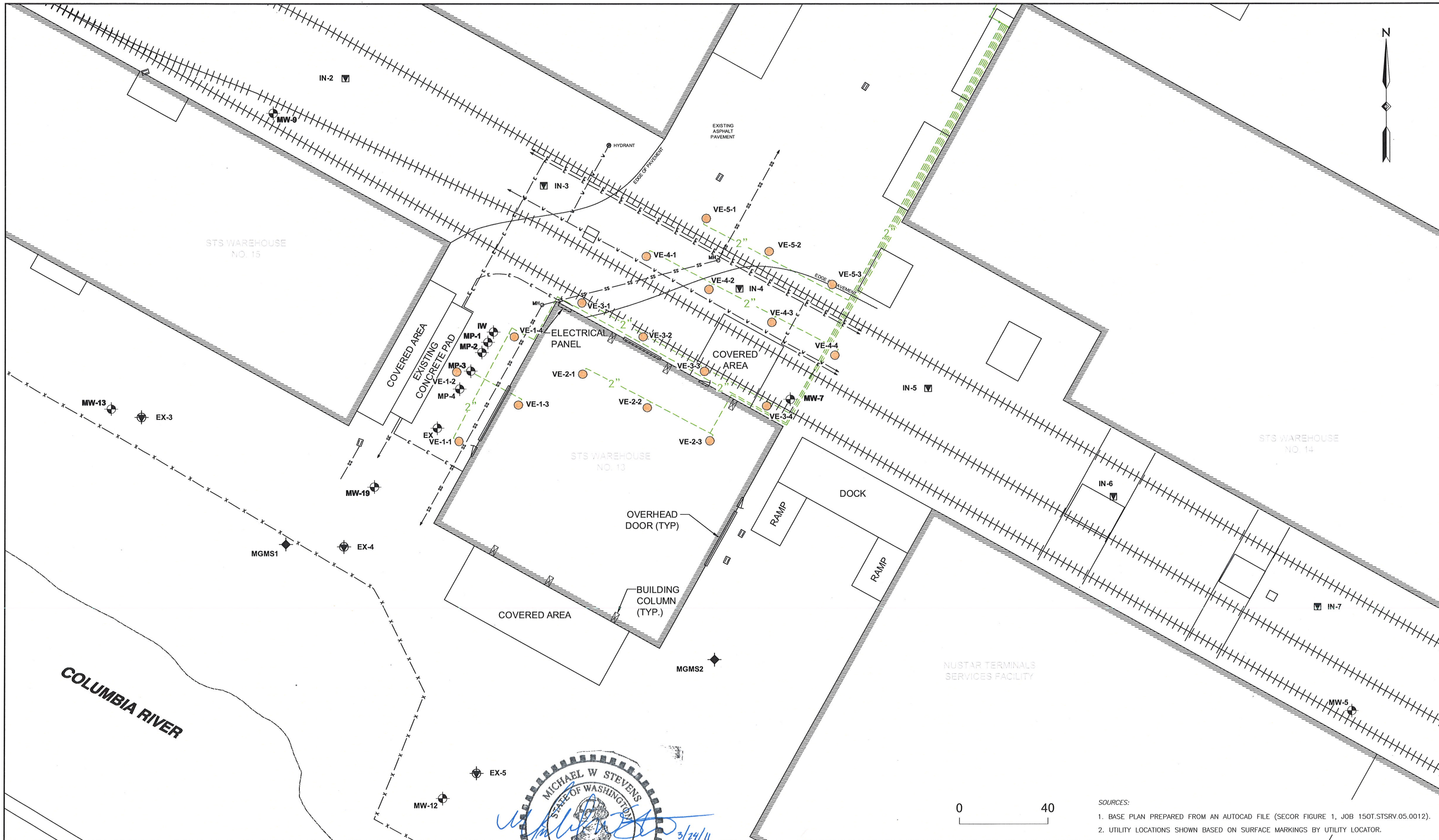

SOURCES:
 1. BASE PLAN PREPARED FROM AN AUTOCAD FILE (SECOR FIGURE 1, JOB 150T.STSRV.05.0012).
 2. UTILITY LOCATIONS SHOWN BASED ON SURFACE MARKINGS BY UTILITY LOCATOR.

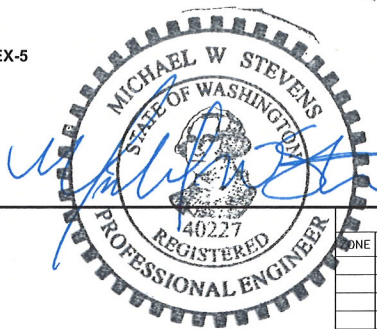

EXTERNAL REFERENCE FILES

UPDATED XREF Base 1126.DWG

LINE	REV.	DESCRIPTION	BY	DATE	APP.

DESIGNED: MWS
 DRAWN: JLP
 CHECKED: HFC
 CHECKED: MWS
 APPROVED: MWS

ASH CREEK ASSOCIATES, INC.
 Environmental and Geotechnical Consultants

SUBMITTED: Michael Stevens
 ASSOCIATE ENGINEER

DATE: 11/1/2010

SITE PLAN

2010 INTERIM ACTION WORK PLAN IMPLEMENTATION
 NUSTAR TERMINALS SERVICES, INC. VANCOUVER FACILITY
 VANCOUVER, WASHINGTON

FILENAME: 1126-09 (DRAWING SET 1)
 AC PROJECT NUMBER: 1126-09
 SCALE: 1" = 40'
 DRAWING NUMBER: B-2
 SHEET NUMBER: 2 OF 6

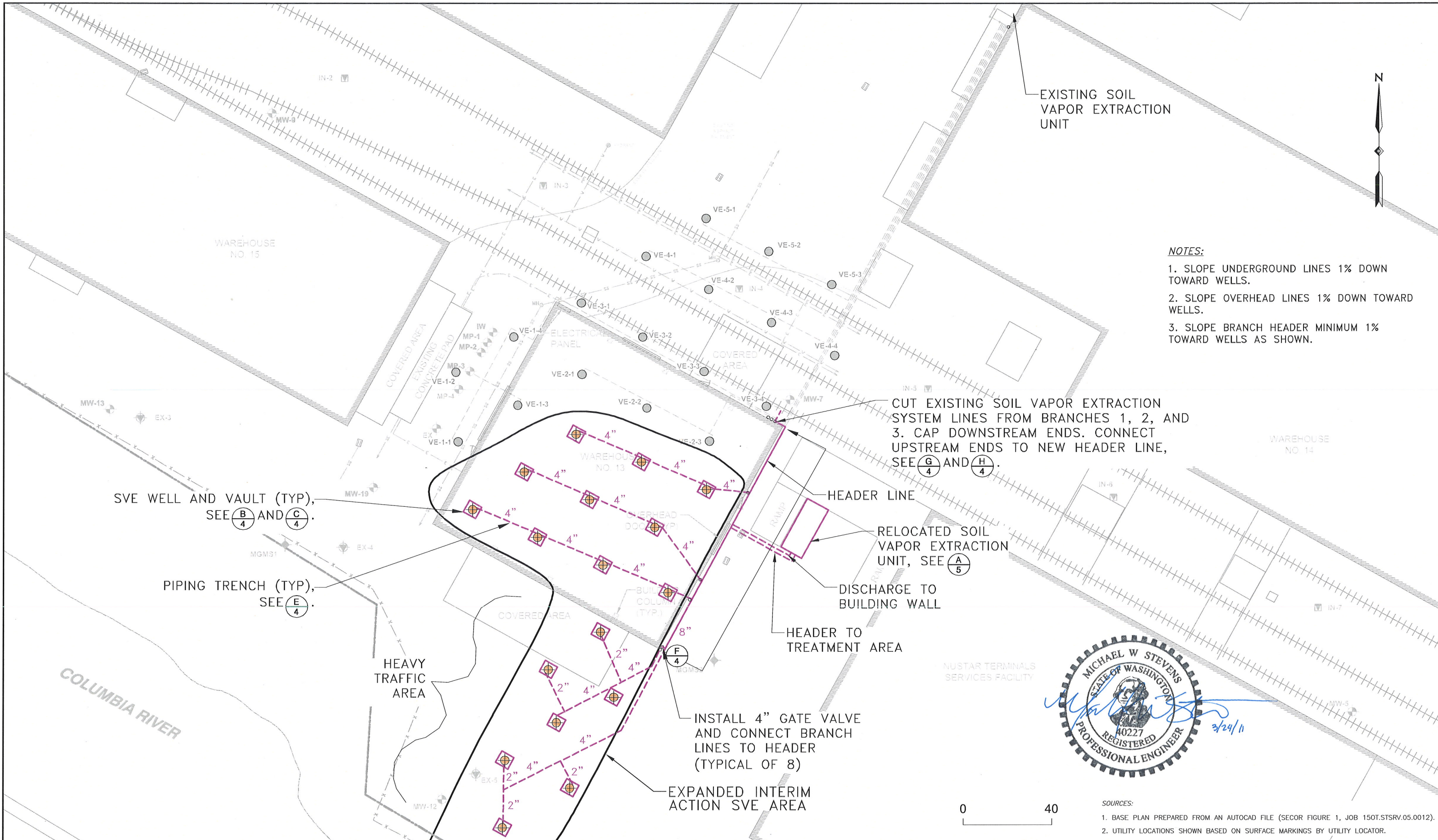

- NOTES:**
1. SLOPE UNDERGROUND LINES 1% DOWN TOWARD WELLS.
 2. SLOPE OVERHEAD LINES 1% DOWN TOWARD WELLS.
 3. SLOPE BRANCH HEADER MINIMUM 1% TOWARD WELLS AS SHOWN.

CUT EXISTING SOIL VAPOR EXTRACTION SYSTEM LINES FROM BRANCHES 1, 2, AND 3. CAP DOWNSTREAM ENDS. CONNECT UPSTREAM ENDS TO NEW HEADER LINE, SEE (G/4) AND (H/4).

SVE WELL AND VAULT (TYP), SEE (B/4) AND (C/4).

PIPING TRENCH (TYP), SEE (E/4).

HEADER LINE

RELOCATED SOIL VAPOR EXTRACTION UNIT, SEE (A/5)

DISCHARGE TO BUILDING WALL

HEADER TO TREATMENT AREA

INSTALL 4" GATE VALVE AND CONNECT BRANCH LINES TO HEADER (TYPICAL OF 8)

EXPANDED INTERIM ACTION SVE AREA



- SOURCES:**
1. BASE PLAN PREPARED FROM AN AUTOCAD FILE (SECOR FIGURE 1, JOB 150T.STSRV.05.0012).
 2. UTILITY LOCATIONS SHOWN BASED ON SURFACE MARKINGS BY UTILITY LOCATOR.



Ash Creek Associates, Inc.
Environmental and Geotechnical Consultants

DESIGNED: MWS
DRAWN: JLP
CHECKED: HFC
CHECKED: HFC
APPROVED: MWS

SUBMITTED: Michael Stevens
ASSOCIATE ENGINEER

DATE: 3/22/2011

EXTERNAL REFERENCE FILES

UPDATED XREF Base 1126.DWG

ZONE	REV.	DESCRIPTION	BY	DATE	APP.

REVISIONS

ZONE	REV.	DESCRIPTION	BY	DATE	APP.

SVE SYSTEM LAYOUT

2010 INTERIM ACTION WORK PLAN IMPLEMENTATION
MUSTAR TERMINALS SERVICES, INC. VANCOUVER FACILITY
VANCOUVER, WASHINGTON

FILENAME	1126-09 (DRAWING SET 2)
AC PROJECT NUMBER	1126-09
SCALE	1" = 40'
DRAWING NUMBER	B-3
SHEET NUMBER	3 OF 6

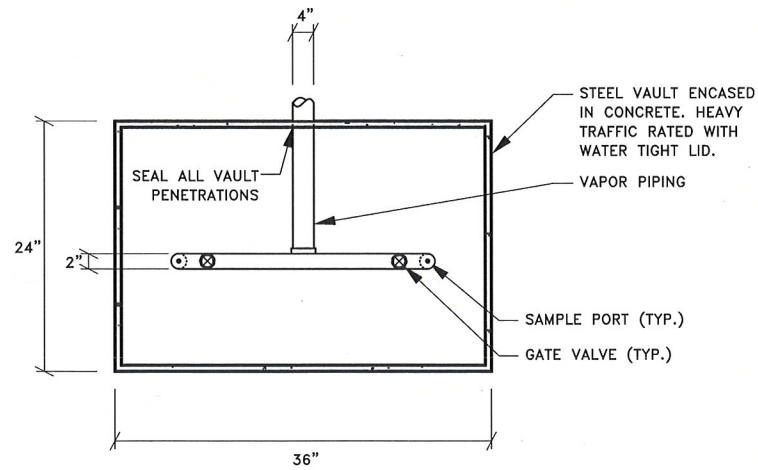

A
4 VAPOR WELL VAULT
NOT TO SCALE

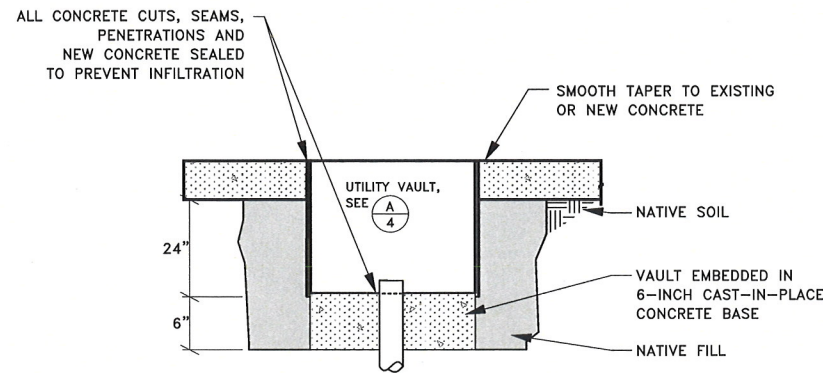

C
4 VAPOR WELL VAULT INSTALLATION DETAIL
NOT TO SCALE

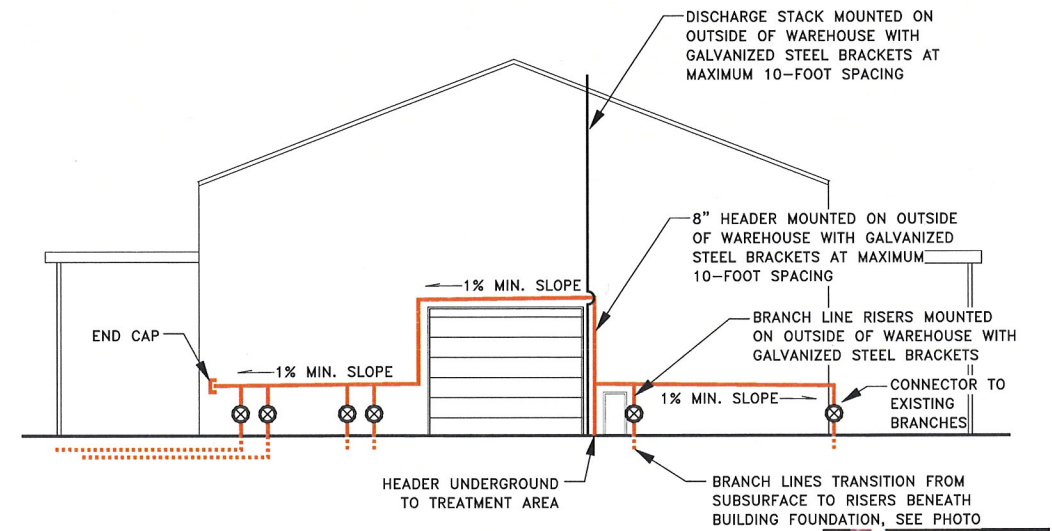

F
4 WAREHOUSE 13 HEADER - EAST ELEVATION
NOT TO SCALE

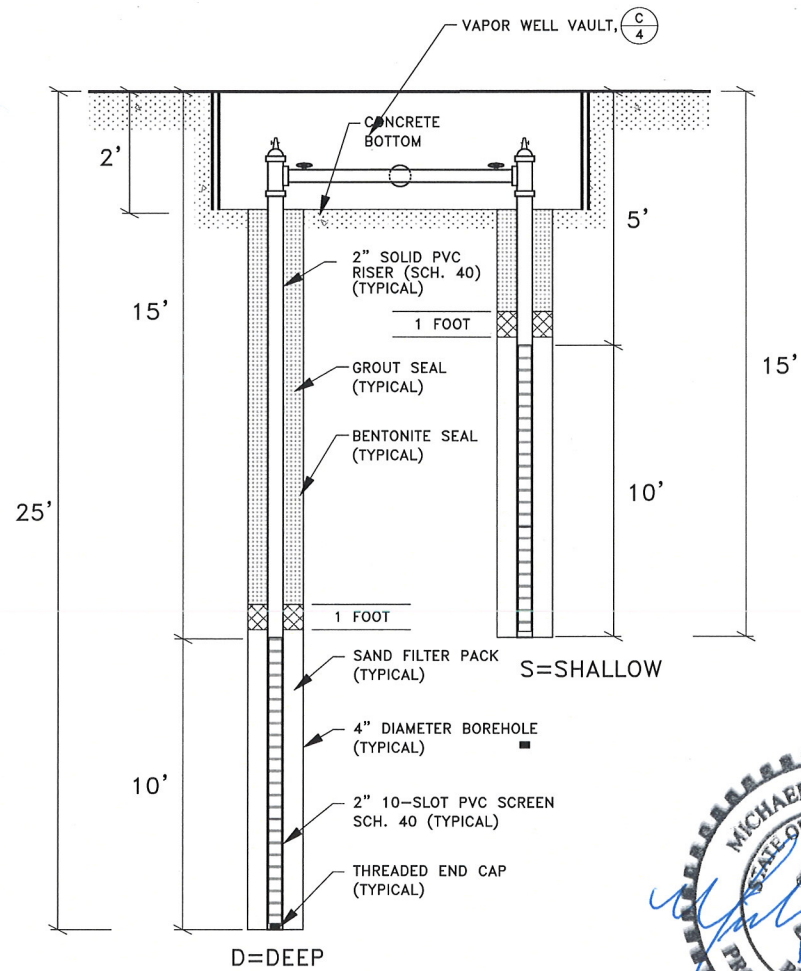

B
4 VAPOR EXTRACTION WELL DETAIL
NOT TO SCALE

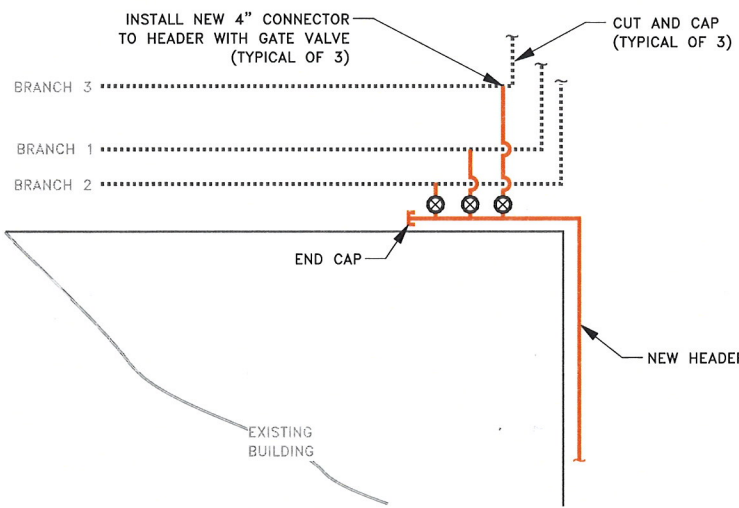

G
4 CONNECTION-EXISTING TO NEW-PLAN VIEW
NOT TO SCALE

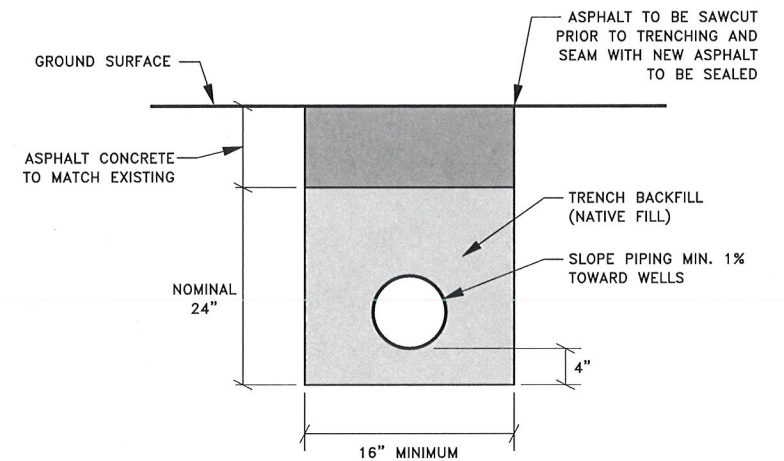

E
4 VAPOR PIPING TRENCH DETAIL
NOT TO SCALE

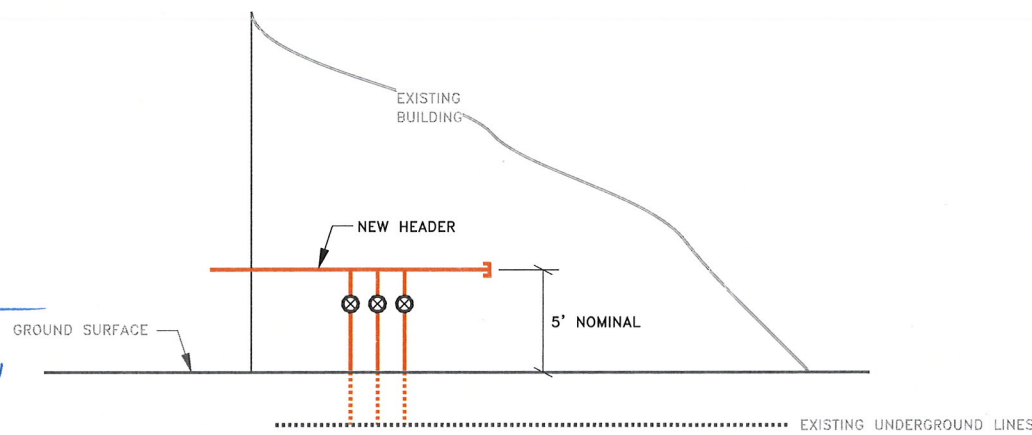

H
4 CONNECTION-EXISTING TO NEW-NORTH ELEVATION
NOT TO SCALE



REVISIONS		BY	DATE	APP.
ZONE	REV.	DESCRIPTION		

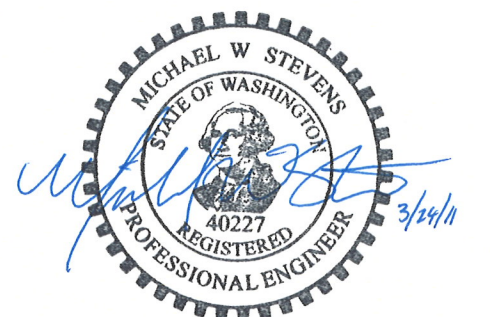
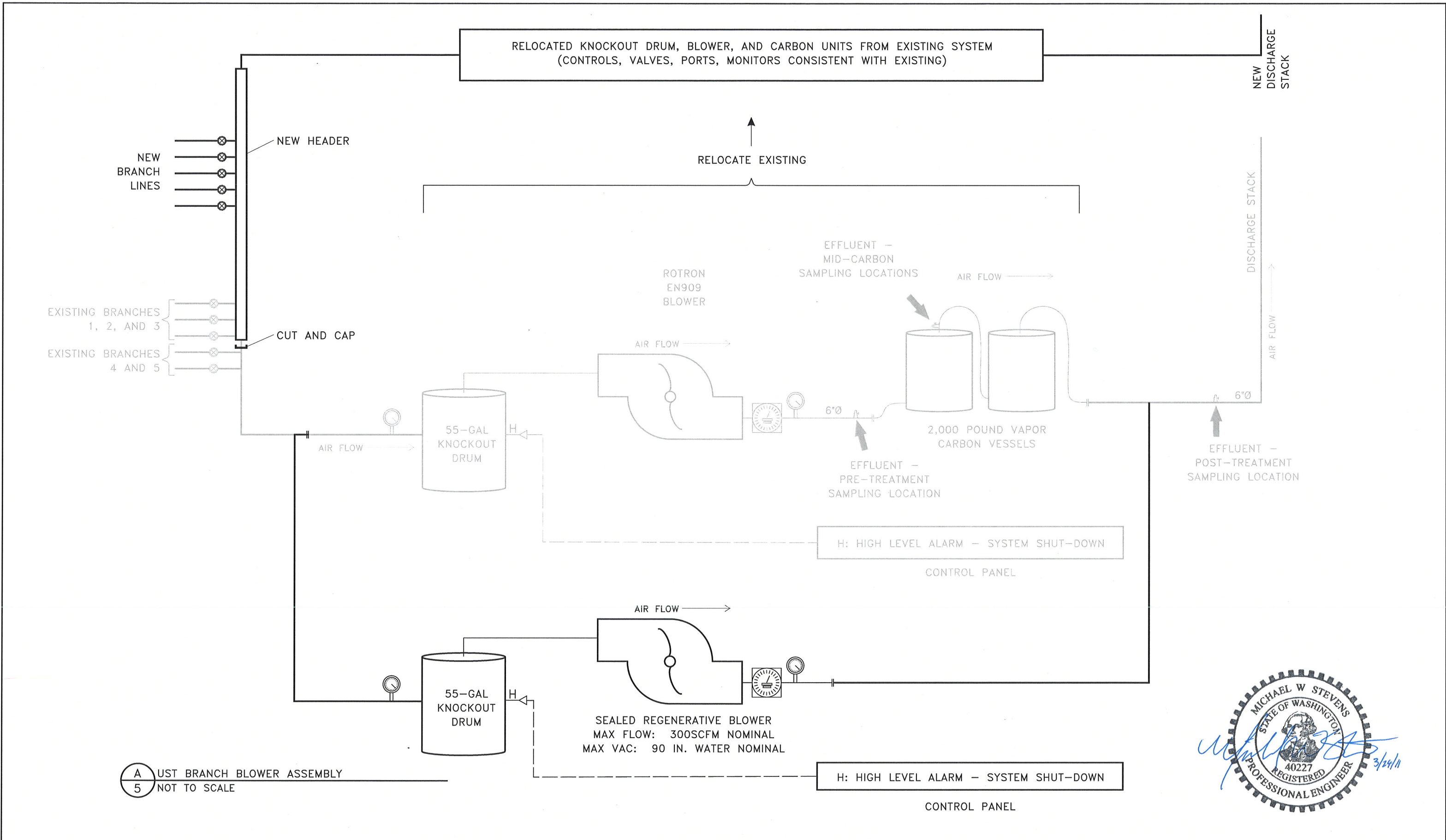

Ash Creek Associates, Inc.
Environmental and Geotechnical Consultants

SUBMITTED: **Michael Stevens**
ASSOCIATE ENGINEER

DATE: 3/22/2011

DESIGNED: MWS
DRAWN: JLP
CHECKED: HFC
CHECKED:
APPROVED: MWS

EXTERNAL REFERENCE FILES

REVISIONS

ZONE	REV.	DESCRIPTION	BY	DATE	APP.

FILENAME: 1126-09 (DETAILS)
AC PROJECT NUMBER: 1126-09
SCALE: NTS
DRAWING NUMBER: B-5
SHEET NUMBER: 5 OF 6

VAPOR FLOW SCHEMATIC

2010 INTERIM ACTION WORK PLAN IMPLEMENTATION
NUSTAR TERMINALS SERVICES, INC. VANCOUVER FACILITY
VANCOUVER, WASHINGTON

GENERAL:

- 1) THE WORK TO BE PERFORMED SHALL CONSIST OF FURNISHING ALL TOOLS, EQUIPMENT, MATERIALS, SUPPLIES, TRANSPORTATION AND SERVICES (INCLUDING FUEL, POWER, WATER AND ESSENTIAL COMMUNICATIONS), AND FOR THE PERFORMANCE OF ALL LABOR OR OTHER OPERATIONS REQUIRED IN STRICT ACCORDANCE WITH THE SPECIFICATIONS AND DRAWINGS. THE WORK SHALL BE COMPLETED, AND ALL WORK, MATERIALS, AND SERVICES NOT EXPRESSLY SHOWN OR CALLED FOR IN THE SPECIFICATIONS AND DRAWINGS WHICH MAY BE NECESSARY FOR THE COMPLETE AND PROPER CONSTRUCTION OF THE WORK IN GOOD FAITH SHALL BE PERFORMED, FURNISHED, AND INSTALLED BY THE CONTRACTOR AS THOUGH ORIGINALLY SO SPECIFIED OR SHOWN.
- 2) DURING ALL SITE ACTIVITIES, EXISTING STRUCTURES (INCLUDING BUT NOT LIMITED TO GROUNDWATER MONITORING WELLS, UTILITIES, PIPING, AND BUILDINGS) SHALL BE PROTECTED FROM DAMAGE CAUSED BY SITE ACTIVITIES. DAMAGED STRUCTURES SHALL BE REPAIRED OR REPLACED AS NECESSARY AT THE CONTRACTOR'S EXPENSE.
- 3) THE CONTRACTOR SHALL LOCATE ALL UNDERGROUND UTILITIES PRIOR TO ANY SUBSURFACE ACTIVITIES.
- 4) IF ANY PORTION OF THIS WORK REQUIRES A PERMIT TO LAWFULLY COMPLETE, THEN IT IS THE RESPONSIBILITY OF THE CONTRACTOR TO OBTAIN THOSE PERMITS.
- 5) CONTRACTOR SHALL COMPLETE ALL WORK IN ACCORDANCE WITH A SITE-SPECIFIC HEALTH AND SAFETY PLAN TO BE PREPARED BY CONTRACTOR. THE PLAN SHALL BE AT LEAST AS STRINGENT AS THE HEALTH AND SAFETY PLAN IN THE RD/RA WORK PLAN (APPENDIX E).

EARTHWORK – MATERIALS:

- 1) IMPORTED FILL: IMPORTED FILL MATERIALS SHALL CONSIST OF SOIL OR ROCK THAT IS ESSENTIALLY FREE OF ORGANICS AND OTHER DELETERIOUS MATERIAL, WITH NO ROCKS OR LUMPS GREATER THAN 1 INCH IN ANY DIMENSION, AND WHICH CAN BE READILY PLACED, GRADED, AND COMPACTED AS NECESSARY.

EARTHWORK EXECUTION:

- 1) TRENCH EXCAVATIONS SHALL HAVE A MINIMUM BOTTOM WIDTH OF TWICE THE ASSOCIATED COMBINED PIPE DIAMETER, AND SHALL ALLOW FOR A MINIMUM OF 4 INCHES OF PIPE BEDDING BENEATH THE PIPES. EXCAVATION WALLS SHALL BE SLOPED OR SHORED AS NECESSARY TO ALLOW THE SAFE AND EFFICIENT COMPLETION OF THE WORK.
- 2) THE POTENTIAL EXISTS THAT SOILS ENCOUNTERED DURING THE TRENCHING ACTIVITIES WILL BE IMPACTED BY CONTAMINANTS (TETRACHLOROETHENE [PCE] AND/OR TRICHLOROETHENE [TCE] AND PETROLEUM SOLVENTS). IN THE EVENT THAT ENCOUNTERED SOIL OR GROUNDWATER SHOW EVIDENCE OF CONTAMINATION OR LNAPL, NOTIFY THE ENGINEER IMMEDIATELY. GROUNDWATER SHOULD NOT BE ENCOUNTERED DURING EXCAVATION ACTIVITIES. ALL SOIL SHALL BE ASSUMED TO BE CONTAMINATED UNTIL TESTING DEMONSTRATES OTHERWISE.
- 3) ALL FILL SHALL BE PLACED IN APPROXIMATELY HORIZONTAL, COMPACTED LAYERS OF UNIFORM THICKNESS. THE LAYERS SHALL BE CARRIED UP FULL WIDTH FROM THE BOTTOM OF THE FILL. EACH LAYER SHALL BE PLACED IN LOOSE LIFTS NOT EXCEEDING 12 INCHES IN THICKNESS. IF THE ENTIRE FINISHED THICKNESS OF MATERIAL IS GREATER THAN 9 INCHES, IT SHALL BE CONSTRUCTED FROM TWO OR MORE LAYERS OF APPROXIMATELY EQUAL THICKNESS.
- 4) FILL IN LIGHTLY TRAVELED AREAS SHALL BE COMPACTED TO A FIRM, NON-YIELDING STATE USING HAND-TAMPING AROUND PIPES AND MECHANICAL COMPACTION ELSEWHERE. FILL IN HEAVY TRAFFIC AREAS (AS IDENTIFIED ON THE DRAWINGS) SHALL BE COMPACTED TO 95 PERCENT OF THE MAXIMUM DENSITY (MODIFIED PROCTOR). COMPACTION BY MECHANICAL MEANS MAY USE ANY APPROPRIATE MACHINES (SUCH AS A BACKHOE-MOUNTED VIBRATORY PLATE OR HAND-OPERATED COMPACTOR) PROVIDED THAT THEY ARE CAPABLE OF COMPACTING THE FILL TO THE SPECIFIED DENSITY AND DO NOT DAMAGE ADJACENT STRUCTURES OR BURIED PIPING.
- 5) STOCKPILES OF EXCAVATED SOIL OR IMPORTED FILL MATERIALS MAY BE STOCKPILED ON-SITE ONLY DURING THE DURATION OF THE EARTHWORK ACTIVITIES AT A LOCATION PRE-APPROVED BY THE ENGINEER. THE LOCATION OF ANY STOCKPILE MAY NOT INTERFERE WITH LOCAL BUSINESSES OR ON-SITE OPERATIONS. STOCKPILES OF EXCAVATED SOIL SHALL BE PLACED IN A MANNER TO PREVENT SEDIMENT FROM REACHING ANY LOCAL STORM DRAIN. IF DUST CONTROL IS NEEDED FOR A STOCKPILE, THE STOCKPILE SHALL BE COVERED BY SHEET PLASTIC.
- 6) DEBRIS (INCLUDING CONCRETE REMOVED DURING SYSTEM INSTALLATION) AND REMOVED SOILS SHALL BE PROPERLY DISPOSED OF AT A PERMITTED DISPOSAL FACILITY. IF SOIL IS TO BE REMOVED FROM THE SITE, IT SHALL BE THE RESPONSIBILITY OF THE ENGINEER TO DETERMINE THE PROPER WASTE DESIGNATION (INCLUDING ALL NECESSARY CHEMICAL ANALYSES). SOIL IMPACTED BY PCE AND/OR TCE MAY BE DESIGNATED AS A HAZARDOUS WASTE AND WILL NEED TO BE HANDLED AND DISPOSED OF ACCORDINGLY.
- 7) CONTRACTOR SHALL ASSESS THE CAPACITY OF THE EXISTING CONDUIT BENEATH THE RAIL LINES WITH REGARDS TO AVAILABLE APACE FOR THE MAIN HEADER PIPE. ALTERNATIVELY, CONTRACTOR SHALL RETAIN A STRUCTURAL ENGINEER AND SCOPE AN OVERHEAD PIPE SUPPORT BETWEEN THE WAREHOUSE BUILDINGS WITH A MINIMUM CLEARANCE SIMILAR TO OTHER OVERHEAD STRUCTURES OVER THE RAIL LINES. SCOPE OF OVERHEAD CROSSING TO BE COORDINATED WITH FACILITY STAFF AND APPROVED BY ENGINEER PRIOR TO IMPLEMENTATION.

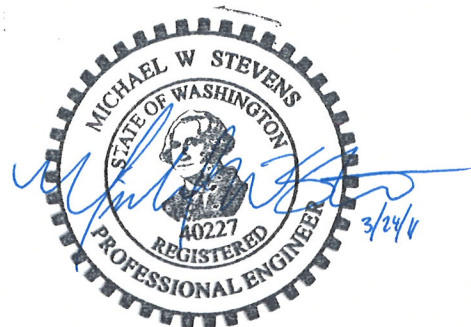

Ash Creek Associates, Inc.
 Environmental and Geotechnical Consultants
 SUBMITTED: Michael Stevens
 ASSOCIATE ENGINEER DATE: 11/1/2010

DESIGNED: MWS
 DRAWN: JLP
 CHECKED: HFC
 CHECKED:
 APPROVED: MWS

EXTERNAL REFERENCE FILES	

REVISIONS				
ZONE	REV.	DESCRIPTION	BY	DATE APP.

SPECIFICATIONS
 2010 INTERIM ACTION WORK PLAN IMPLEMENTATION
 NUSTAR TERMINALS SERVICES, INC. VANCOUVER FACILITY
 VANCOUVER, WASHINGTON

FILENAME
1126-09 (DETAILS)
AC PROJECT NUMBER
1126-09
SCALE
NTS
DRAWING NUMBER
B-6
SHEET NUMBER
6 OF 6

Appendix C

Design Support

**Table C-1
Piping Size Calculator
Nustar Vancouver**

System Air Flow [CFM]	Air Flow Per Well [CFM]	Head Losses ["H2O], Including Fittings								Head Loss ["H2O]
		Well		Branch Line (4 Wells)						
		1.5"	2"	2"	3"	4"	4"	6"	8"	
400	23.5	1.73	0.41	9.07	1.19	0.28	58.49	7.64	1.80	2.49

Notes:

1. Head loss calculated from equation for friction loss in circular duct: $dP = (0.109136 Q^{1.9}) / (d^{5.02})$ [inches/100 feet]
2. Head loss associated with longest piping run of listed type
3. Pipe size selected such that head loss is less than 1 inch of water in 100 feet of pipe

[Help](#)

Site Name:
 Location:
 Project No.:

Step 1: Select a Substrate from the EOS® Family of Bioremediation Products

Substrate Selected (pick from drop down list)
 For Product Literature Click Here

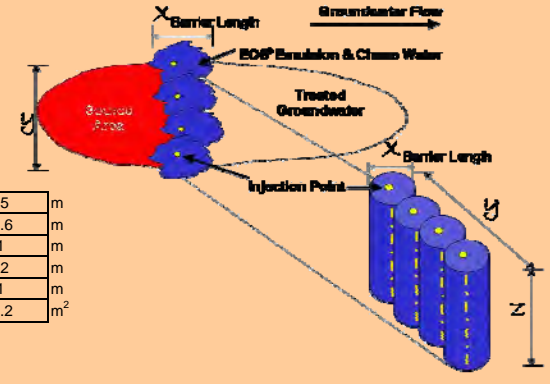

Step 2: EOS® Consumption During Contaminant Biodegradation / Biotransformation

Section A: Treatment Area Dimensions

Length of treatment area parallel to groundwater flow, "x"	<input type="text" value="320"/>	ft	<input type="text" value="97.5"/>	m
Width of treatment area perpendicular to groundwater flow, "y"	<input type="text" value="330"/>	ft	<input type="text" value="100.6"/>	m
Minimum depth to contamination	<input type="text" value="30"/>	ft	<input type="text" value="9.1"/>	m
Maximum depth of contamination	<input type="text" value="50"/>	ft	<input type="text" value="15.2"/>	m
Treatment thickness, "z"	<input type="text" value="20"/>	ft	<input type="text" value="6.1"/>	m
Treatment zone cross-sectional area, A = y * z	<input type="text" value="6,600"/>	ft ²	<input type="text" value="613.2"/>	m ²

Section B: Groundwater Flow Rate / Site Data

Soil Characteristics

Nominal Soil Type (pick from drop down list)	<input type="text" value="Silty Sand"/>
Total Porosity (accept default or enter n)	<input type="text" value="0.28"/> (decimal)
Effective Porosity (accept default or enter n _e)	<input type="text" value="0.17"/> (decimal)
Soil bulk density; (1-n)*2.65 g/cc (accept calculated or enter dry bulk density)	<input type="text" value="1.91"/> g/cc <input type="text" value="119"/> lbs / ft ³

Hydraulic Characteristics

Hydraulic Conductivity (accept default or enter K)	<input type="text" value="29"/> ft/day <input type="text" value="1.0E-02"/> cm/sec
Hydraulic Gradient (accept default or enter i)	<input type="text" value="0.005"/> ft/ft

Note: Since the hydraulic gradient (i = dh/dx) is negative, we ask you to enter -i in the EOS® Design Tool so that you can enter a positive number for convenience.

Non-reactive Transport Velocity, V _x = -(K x i) / n _e	<input type="text" value="0.85"/> ft/day <input type="text" value="0.260"/> m/day
Groundwater flow rate through treatment zone, Q = -KiA	<input type="text" value="7158.36"/> gallons/day <input type="text" value="27,099.22"/> L/day

Section C: Calculated Contact Length

Contact time (τ) between oil and contaminants (accept default or enter τ)	<input type="text" value="60"/>	typical values 60 to 180 days, see comment
Calculated Contact Length (x) = τ * V _x	<input type="text" value="51.2"/>	ft <input type="text" value="15.6"/> m

Treatment zone volume	<input type="text" value="2,112,000"/>	ft ³ <input type="text" value="59,805.2"/> m ³
Treatment zone groundwater volume (volume * effective porosity)	<input type="text" value="2,685,619"/>	gallons <input type="text" value="10,166.881"/> L

Section D: Design Lifespan For One Application

Estimated total groundwater volume treated over design life	<input type="text" value="5"/> year(s) <input type="text" value="15,749,626"/> gallons	typical values 5 to 10 years <input type="text" value="59,622,961"/> L
---	--	--

Section E: Electron Acceptors

Inputs	Typical Value	GW Conc. (mg/L)	MW (g/mole)	e ⁻ equiv./mole	Stoichiometry Contaminant / H ₂ (wt/wt H ₂)	Hydrogen Demand (g H ₂)
Dissolved Oxygen (DO)	<input type="text" value="0 to 8"/>	<input type="text" value="2"/>	32.0	4	7.94	15024.05902
Nitrate Nitrogen (NO ₃ ⁻ - N)	<input type="text" value="1 to 10"/>	<input type="text" value="320"/>	62.0	5	12.30	1550689.897
Sulfate (SO ₄ ²⁻)	<input type="text" value="10 to 500"/>	<input type="text" value="5"/>	96.1	8	11.91	25024.14488
Tetrachloroethene (PCE), C ₂ Cl ₄		<input type="text" value="1.4"/>	165.8	8	20.57	4058.592351
Trichloroethene (TCE), C ₂ HCl ₃		<input type="text" value="0.6"/>	131.4	6	21.73	1646.549571
cis-1,2-dichloroethene (c-DCE), C ₂ H ₂ Cl ₂		<input type="text" value="0.2"/>	96.9	4	24.05	495.9077939
Vinyl Chloride (VC), C ₂ H ₃ Cl		<input type="text" value="0.1"/>	62.5	2	31.00	192.3047439
Carbon tetrachloride, CCl ₄			153.8	8	19.08	
Chloroform, CHCl ₃			119.4	6	19.74	
sym-tetrachloroethane, C ₂ H ₂ Cl ₄			167.8	8	20.82	
1,1,1-Trichloroethane (TCA), CH ₃ CCl ₃			133.4	6	22.06	
1,1-Dichloroethane (DCA), CH ₃ CHCl ₂			99.0	4	24.55	
Chloroethane, C ₂ H ₅ Cl			64.9	2	32.18	
Perchlorate, ClO ₄ ⁻			99.4	8	12.33	
Hexavalent Chromium, Cr(VI)			52.0	3	17.20	
User added	<input type="text"/>	<input type="text"/>	<input type="text"/>	<input type="text"/>		
User added	<input type="text"/>	<input type="text"/>	<input type="text"/>	<input type="text"/>		
User added	<input type="text"/>	<input type="text"/>	<input type="text"/>	<input type="text"/>		

Section F: Additional Hydrogen Demand and Carbon Losses

Generation (Potential Amount Formed)	Typical Value	GW Conc. (mg/L)	MW (g/mole)	e ⁻ equiv./mole	Stoichiometry Contaminant / H ₂ (wt/wt H ₂)	Hydrogen Demand (g H ₂)	DOC Released (moles)
Estimated Amount of Fe ²⁺ Formed	<input type="text" value="10 to 100"/>	<input type="text" value="50"/>	55.8	1	55.41	53804.26402	
Estimated Amount of Manganese (Mn ²⁺) Formed		<input type="text" value="5"/>	54.9	2	27.25	10938.50932	
Estimated Amount of CH ₄ Formed	<input type="text" value="5 to 20"/>	<input type="text" value="10"/>	16.0	8	1.99	299672.0356	
Target Amount of DOC to Release	<input type="text" value="60 to 100"/>	<input type="text" value="80"/>	12.0				<input type="text" value="397122.38"/>

Design Safety Factor: typical values 1 to 3

Calculations assume:
 1.) all reactions go to completion during passage through emulsified edible oil treated zone; and,
 2.) perfect reaction stoichiometry.

EOS® Requirement Calculations Based on Hydrogen Demand and Carbon Losses

Stoichiometric Hydrogen Demand	<input type="text" value="8,641.2"/>	pounds
DOC Released	<input type="text" value="45,345.0"/>	pounds

EOS® Requirement Based on Hydrogen Demand and Carbon Loss

lbs

Step 3: EOS® Requirement Based on Attachment by Aquifer Material

Soil Characteristics

Effective treatment thickness, "z _e " (typically less than 40%)	<input type="text" value="0.25"/>
--	-----------------------------------

For Additional Information on Effective Thickness, Click Here

Weight of sediment to be treated	<input type="text" value="62,891,425"/>	lbs
Adsorptive Capacity of Soil (accept default or enter site specific value)	<input type="text" value="0.0016"/>	lbs EOS® / lbs sediment

EOS® Attachment by Aquifer Material¹

- Fine sand with some clay 0.001 to 0.002 lbs EOS® / lbs soil
- Sand with higher silt/clay content 0.002 to 0.004 lbs EOS® / lbs soil

¹Default values provided based on laboratory studies completed by NCSU
 For Additional Data, Click Here

EOS® Requirement Based on Oil Entrapment by Aquifer Material

lbs

Summary – How much EOS® do you need?

Suggested Quantity of EOS® for Your Project

drums

[†]Exclusive license agreement with Solutions-IES under U.S. Patent # 6,398,960, European Union Patent # EP 1 315 675 and several other pending international patents.
^{††}EOS® is a registered trademark of EOS Remediation, Inc.

PROJECT : AS-BUILT
=====

SCOPE : RESULTS OF FULL-SCALE PERMEABILITY TESTS
TEST DATE : 10/19/2010
WELL NUMBER : VE2-3

1. MODEL INPUT SUMMARY

MODEL DOMAIN : THICKNESS = 914.400 cm
: ESTIMATED PERMEABILITY = 0.100E-06 cm^2
: ESTIMATED ANISOTROPY RATIO = 1.00
UPPER CONFINING UNIT : THICKNESS = 10.140 cm
: ESTIMATED PERMEABILITY = .100E-08 cm^2
WELL DEPTH (HANTUSH d) : TOP OF SCREEN = 152.40 cm
WELL DEPTH (HANTUSH l) : BOTTOM OF SCREEN = 609.60 cm
WELL RADIUS : EFFECTIVE RADIUS = 10.14 cm
AIR FLOW DIRECTION : VAPOR EXTRACTION

2. MODEL OUTPUT SUMMARY

AIR TEMP	SOIL TEMP	ATMOS. PRESS.	SYSTEM PRESS.	FLOW TYPE	SCALE	PREVAIL. FLOW	ACTUAL FLOW
degC	degC	atm	atm		cm^3/sec	cm^3/sec	

18.00	12.00	1.000	0.946	NONE	--	--	14200.000
-------	-------	-------	-------	------	----	----	-----------

MASS FLOW	HORIZON. PERM.	VERTICAL PERM.	LEAKAGE RATIO(k/b)	ANISOTPY RATIO (kr/kz)	MEAN OF PRESS.	STD DEV OF ERROR
g/sec	cm^2	cm^2	cm^2/cm		IN PRESS.	

16.362	0.239E-05	0.239E-05	0.986E-10	1.000	0.167-306	0.544+292
--------	-----------	-----------	-----------	-------	-----------	-----------

60.96	-381.00	-0.464324E-01	-0.567044E-03	-0.464358E-01
121.92	-381.00	-0.212665E-01	-0.529632E-03	-0.212731E-01
182.88	-381.00	-0.127337E-01	-0.481786E-03	-0.127428E-01
243.84	-381.00	-0.869164E-02	-0.424907E-03	-0.870202E-02
304.80	-381.00	-0.631360E-02	-0.362399E-03	-0.632399E-02
365.76	-381.00	-0.487147E-02	-0.300803E-03	-0.488075E-02
426.72	-381.00	-0.393212E-02	-0.243122E-03	-0.393962E-02
487.68	-381.00	-0.328487E-02	-0.191412E-03	-0.329045E-02
548.64	-381.00	-0.281772E-02	-0.146545E-03	-0.282153E-02
609.60	-381.00	-0.246708E-02	-0.108416E-03	-0.246946E-02
670.56	-381.00	-0.219500E-02	-0.767667E-04	-0.219634E-02
731.52	-381.00	-0.197782E-02	-0.508988E-04	-0.197847E-02
792.48	-381.00	-0.180027E-02	-0.300292E-04	-0.180052E-02
853.44	-381.00	-0.165217E-02	-0.133816E-04	-0.165222E-02
914.40	-381.00	-0.152651E-02	-0.238169E-06	-0.152651E-02
975.36	-381.00	-0.141835E-02	0.100348E-04	-0.141838E-02
1036.32	-381.00	-0.132411E-02	0.179812E-04	-0.132423E-02
1097.28	-381.00	-0.124115E-02	0.240567E-04	-0.124138E-02
1158.24	-381.00	-0.116746E-02	0.286378E-04	-0.116781E-02

VOLUMETRIC FLOW SIGN CONVENTION :

NEGATIVE HORIZONTAL FLOW => FLOW TOWARDS WELL

POSITIVE HORIZONTAL FLOW => FLOW AWAY FROM WELL

NEGATIVE VERTICAL FLOW => FLOW UPWARDS

POSITIVE VERTICAL FLOW => FLOW DOWNWARDS

Appendix D

Bioremediation Design

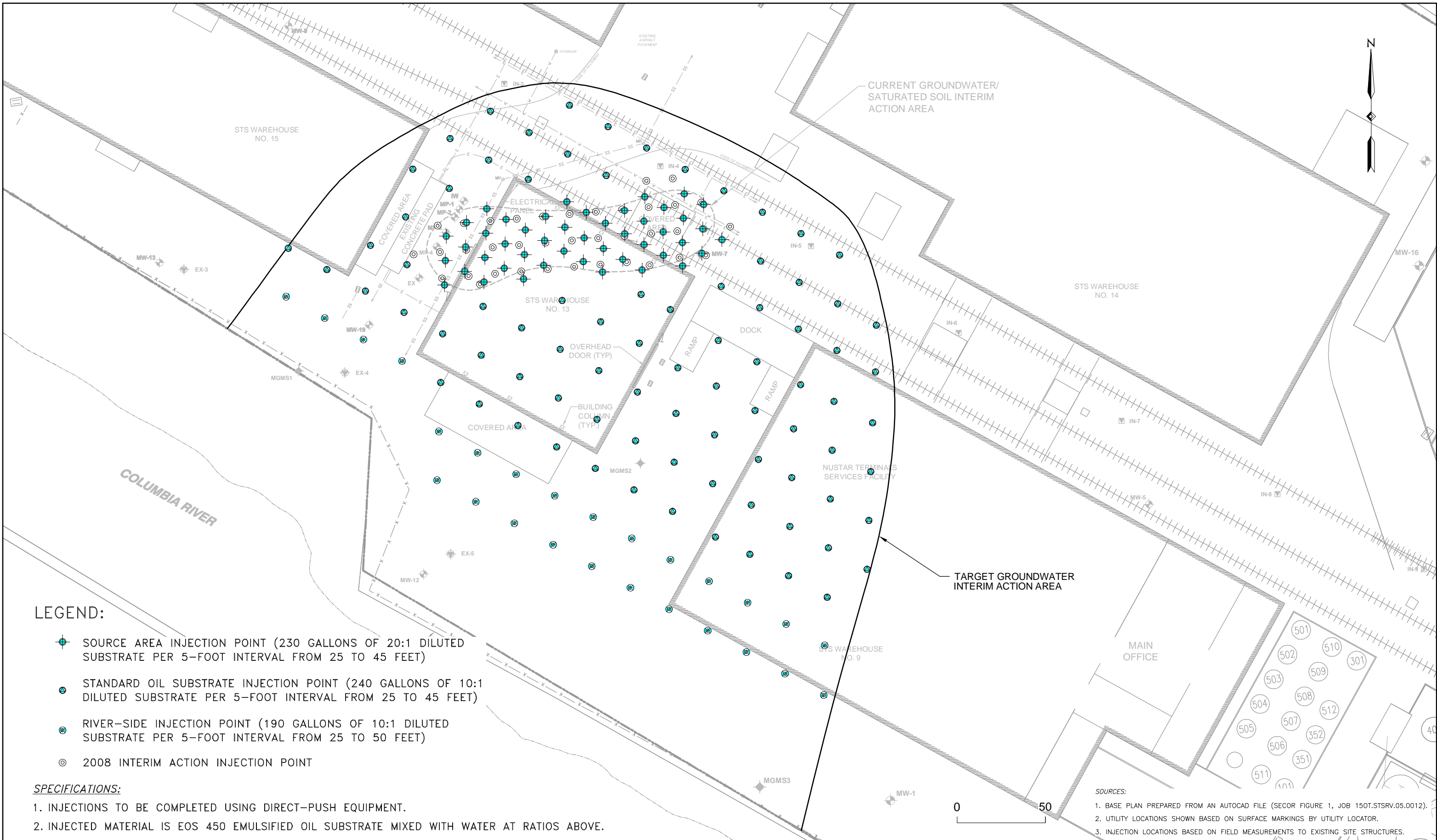

LEGEND:

- SOURCE AREA INJECTION POINT (230 GALLONS OF 20:1 DILUTED SUBSTRATE PER 5-FOOT INTERVAL FROM 25 TO 45 FEET)
- STANDARD OIL SUBSTRATE INJECTION POINT (240 GALLONS OF 10:1 DILUTED SUBSTRATE PER 5-FOOT INTERVAL FROM 25 TO 45 FEET)
- RIVER-SIDE INJECTION POINT (190 GALLONS OF 10:1 DILUTED SUBSTRATE PER 5-FOOT INTERVAL FROM 25 TO 50 FEET)
- 2008 INTERIM ACTION INJECTION POINT

SPECIFICATIONS:

1. INJECTIONS TO BE COMPLETED USING DIRECT-PUSH EQUIPMENT.
2. INJECTED MATERIAL IS EOS 450 EMULSIFIED OIL SUBSTRATE MIXED WITH WATER AT RATIOS ABOVE.

SOURCES:

1. BASE PLAN PREPARED FROM AN AUTOCAD FILE (SECOR FIGURE 1, JOB 150T.STSRV.05.0012).
2. UTILITY LOCATIONS SHOWN BASED ON SURFACE MARKINGS BY UTILITY LOCATOR.
3. INJECTION LOCATIONS BASED ON FIELD MEASUREMENTS TO EXISTING SITE STRUCTURES.

Ash Creek Associates, Inc.
 Environmental and Geotechnical Consultants
 SUBMITTED: Michael Stevens ASSOCIATE ENGINEER DATE: 11/1/2010

DESIGNED: MWS
DRAWN: JLP
CHECKED: HFC
CHECKED: HFC
APPROVED: MWS

EXTERNAL REFERENCE FILES

UPDATED XREF Base 1126.DWG

ZONE		REVISIONS		BY	DATE	APP.
REV.		DESCRIPTION				

ENHANCED BIOREMEDIATION LAYOUT
 2010 INTERIM ACTION WORK PLAN IMPLEMENTATION
 NUSTAR TERMINALS SERVICES, INC. VANCOUVER FACILITY
 VANCOUVER, WASHINGTON

FILENAME 1126-09 (DRAWING SET 3)
AC PROJECT NUMBER 1126-09
SCALE 1" = 50'
DRAWING NUMBER D-1
SHEET NUMBER 1 OF 1