

**STATE OF WASHINGTON
DEPARTMENT OF ECOLOGY**

In the Matter of Remedial Action by:

**CITY OF BELLINGHAM AND PORT
OF BELLINGHAM**

FIRST AMENDMENT TO
AGREED ORDER No. 1778

I. INTRODUCTION

Agreed Order No. 1778 (2005 Order), entered into by the State of Washington, Department of Ecology (Ecology), the City of Bellingham (City), and the Port of Bellingham (Port) in 2005, requires the City and the Port to perform a Remedial Investigation/Feasibility Study (RI/FS) at the Cornwall Avenue Landfill Site (Site). The Site is generally located at the south end of Cornwall Avenue in Bellingham, Washington.

This First Amendment to the 2005 Order (First Amendment) requires that the City and Port perform an interim action to reduce stormwater infiltration through the Site by placing and contouring imported dredged sediments, and covering this material with a low-permeability liner. The interim action will also reduce potential migration of landfill gas to off-Site structures or utility lines by installing a landfill gas collection and passive venting system. The First Amendment also contemplates additional interim actions and sets out a process for approval of interim actions proposed by the City and the Port.

II. JURISDICTION

This amendment to the 2005 Order is issued by Ecology pursuant to RCW 70.105D.050(1).

III. AMENDMENT

This amendment does not attempt to recite all the provisions of the 2005 Order. Provisions of the 2005 Order not specifically addressed in this amendment remain in full force and effect.

The 2005 Order is hereby amended as follows:

1. Section III (Ecology Determinations) of the 2005 Order is amended to add the following determination in addition to the determinations already set forth:

9. Under WAC 173-340-430, an interim action is a remedial action that is technically necessary to reduce a threat to human health or the environment by eliminating or substantially reducing one or more pathways for exposure to a hazardous substance, that corrects a problem that may become substantially worse or cost substantially more to address if the remedial action is delayed, or that is needed to provide for completion of a site hazard assessment, remedial investigation/feasibility study or design of a cleanup action. The interim action will provide a low-permeability cover over more than half of the Site, limiting infiltration of stormwater through refuse and the resulting discharge of refuse-affected groundwater to Bellingham Bay. The interim action will also reduce potential migration of landfill gas to off-Site structures or utility lines by installing a landfill gas collection and passive venting system. The interim action is anticipated to be consistent with the final cleanup action to be selected for the Site and will also provide the material needed to help establish final grades for the drainage, collection, and management of stormwater. Such circumstances warrant interim action consistent with WAC 173-340-430. Additional interim actions are

contemplated for this Site and may be proposed by the City and Port in the future.

Ecology will determine if any of the proposed additional interim actions are warranted.

2. Section IV (Work to Be Performed) of the 2005 Order is hereby amended to add the following requirements in addition to those requirements already set forth:

6. The City and the Port shall perform an interim action to reduce stormwater infiltration and collect landfill gas at the Site by implementing the attached Work Plan, Exhibit A, which is an integral and enforceable part of this Order. The interim action will be implemented according to the schedule contained in Exhibit A.

7. The City and the Port may propose that additional interim actions be taken. Should Ecology determine a particular interim action proposed by the City and Port may be warranted, the City and the Port will prepare and submit a work plan that includes a proposed scope of work and schedule (Work Plan). Interim action work plans are subject to public review and comment. Upon approval by Ecology following public review, the Work Plan becomes an integral and enforceable part of this Order, and the City and the Port are required to perform the interim action according to the Work Plan and schedule contained therein.

3. In Section V.4 (Terms and Conditions of Order, Designated Project Coordinators) the designations for project coordinators are replaced as follows:

The project coordinator for Ecology is:

Robert D. Swackhamer, PE
Washington Department of Ecology
Toxics Cleanup Program
PO Box 47600.
Olympia, WA 98504-7600
(360) 407-7210
Email: Robert.swackhamer@ecy.wa.gov

The project coordinator for the City of Bellingham is:

Amy Kraham, Assistant City Attorney
City of Bellingham
210 Lottie Street
Bellingham, WA 98225
(360) 778-8278
Email: AKraham@cob.org

The project coordinator for the Port of Bellingham is:

Brian D. Gouran
Port of Bellingham
PO Box 1677
Bellingham, WA 98227
(360) 676-2500
Email: BrianG@portofbellingham.com

4. Subsection A of Section V.10 (Reservation of Rights/No Settlement) is replaced in its entirety by the following language:

A. Ecology nevertheless reserves its rights under Chapter 70.105D RCW, including the right to require additional or different remedial actions at the Site should it deem such actions necessary to protect human health and the environment, and to issue orders, separate and apart from this Agreed Order, requiring such remedial actions. The Port and City expressly reserve their rights with regard to any future agency action not covered by the scope of this Order.

5. Section V.12 (Compliance with Other Applicable Laws) of the 2005 Order is replaced in its entirety by the following language:

A. All actions carried out by the City and the Port pursuant to this Order shall be done in accordance with all applicable federal, state, and local requirements, including requirements to obtain necessary permits, except as provided in RCW 70.105D.090. At this time, no federal, state or local requirements have been identified as being applicable to the actions related to the RI/FS work required by this Order. The permits or specific federal, state or local requirements that the agency has determined are applicable to the specific interim action required by this Order and that are known at the time of entry of this Order have been identified in the Work Plan, Exhibit A. The permits or specific federal, state or local requirements applicable to any future interim action that Ecology may approve will be identified in the work plan for that interim action, which will be subject to public comment. Ecology's approval of any such work plan following public comment reflects Ecology's determination as to the permits or specific federal, state or local requirements that apply.

B. Pursuant to RCW 70.105D.090(1), the City and the Port are exempt from the procedural requirements of Chapters 70.94, 70.95, 70.105, 77.55, 90.48, and 90.58 RCW and of any laws requiring or authorizing local government permits or approvals. However, the City and the Port shall comply with the substantive requirements of such permits or approvals. At this time, no state or local permits or approvals have been identified as being applicable but procedurally exempt under this Section to the RI/FS work required by this Order. As to the specific interim action required by this Order, the exempt permits or approvals and the applicable substantive requirements of those permits or approvals, as they are known at the time of entry of this Order, have been identified in the Work Plan, Exhibit A. As to any future interim action that Ecology may approve, any exempt permits or approvals and the applicable substantive requirements of those permits or approvals will be identified in the work plan for that interim action, which will be subject to public comment. Ecology's approval of any such work plan following public comment reflects Ecology's determination on the substantive requirements that apply.

The City and the Port have a continuing obligation to determine whether additional permits or approvals addressed in RCW 70.105D.090(1) would otherwise be required for the remedial action under this Order. In the event either Ecology or the City or the Port determine that additional permits or approvals addressed in RCW 70.105D.090(1) would otherwise be required for the remedial action under this Order, it shall promptly notify the other party of its determination. Ecology shall determine whether Ecology or the City and the Port shall be responsible to contact the appropriate state and/or local agencies. If Ecology so requires, the City and the Port shall promptly consult with the appropriate state and/or local agencies and provide Ecology with written documentation from those agencies of the substantive requirements those agencies believe are applicable to the remedial action. Ecology shall make the final determination on the additional substantive requirements that must be met by the City and the Port and on how they must meet those requirements. Ecology shall inform the City and the Port in writing of these requirements. Once established by Ecology, the additional requirements shall be enforceable requirements of this Order. The City and the Port shall not begin or continue the remedial action potentially subject to the additional requirements until Ecology makes its final determination.

C. Pursuant to RCW 70.105D.090(2), in the event Ecology determines that the exemption from complying with the procedural requirements of the laws referenced in RCW 70.105D.090(1) would result in the loss of approval from a federal agency that is necessary for the State to administer any federal law, the exemption shall not apply and the City and the Port shall comply with both the procedural and substantive requirements of the laws referenced in RCW 70.105D.090(1), including any requirements to obtain permits.

IV. SIGNATURE AUTHORITY

The undersigned representative of each party hereby certifies that he or she is fully authorized to enter into this First Amendment and to execute and legally bind such party to the same.

V. EFFECTIVE DATE

This First Amendment shall be effective upon execution by the City, the Port and Ecology.

Effective date of this Order: _____

CITY OF BELLINGHAM

**STATE OF WASHINGTON
DEPARTMENT OF ECOLOGY**

Dan Pike
Mayor, City of Bellingham
(360) 778-8100

Robert W. Warren, P. Hg., MBA
Section Manager
Toxics Cleanup Program
Northwest Regional Office
(425) 649-7054

Date Signed: _____

Date Signed: _____

APPROVED AS TO FORM:

PORT OF BELLINGHAM

Office of the City Attorney

Charles Sheldon
Executive Director
Telephone: (360) 676-2500

ATTEST: _____
Finance Director
Date Signed: _____

Date Signed: _____

EXHIBIT A

Public Review Draft Cornwall Avenue Landfill Interim Action Plan Bellingham, Washington

May 10, 2011

Prepared for
**Port of Bellingham
Bellingham, Washington**

 **LANDAU
ASSOCIATES**
130 2nd Avenue South
Edmonds, WA 98020
(425) 778-0907

TABLE OF CONTENTS

	<u>Page</u>
1.0 INTRODUCTION	1-1
1.1 BASIS FOR INTERIM ACTION	1-1
1.2 SITE LOCATION	1-2
1.3 SITE HISTORY	1-2
1.4 REPORT ORGANIZATION	1-3
2.0 PHYSICAL AND ENVIRONMENTAL CONDITIONS	2-1
2.1 SITE PHYSICAL CONDITIONS	2-1
2.2 SITE ENVIRONMENTAL CONDITIONS	2-2
2.3 GATE 3 SEDIMENT (BENEFICIAL REUSE MATERIAL)	2-2
2.3.1 Gate 3 Sediment Physical Properties	2-3
2.3.2 Gate 3 Sediment Quality	2-4
3.0 INTERIM ACTION	3-1
3.1 PURPOSE OF THE INTERIM ACTION	3-1
3.2 DESCRIPTION OF INTERIM ACTION	3-2
3.2.1 Grading and Capping	3-2
3.2.2 Stormwater Management	3-3
3.2.3 LFG Control	3-4
3.2.4 Sea Level Rise	3-5
3.2.5 Overwater Walkway	3-7
3.2.6 Construction Timing	3-7
3.3 EVALUATION OF DIOXIN MOBILITY	3-8
3.3.1 Infiltration Pathway	3-8
3.3.2 Inundation Pathway	3-9
3.3.3 Measurement of Dioxins/Furans Concentrations in Groundwater	3-10
3.4 APPLICABLE, RELEVANT, AND APPROPRIATE REGULATORY REQUIREMENTS	3-10
3.4.1 Permits and Other Requirements	3-11
3.4.1.1 NPDES Construction Stormwater General Permit	3-11
3.4.1.2 State Environmental Policy Act (SEPA)	3-11
3.4.2 Permit Exemptions and Applicable Substantive Requirements	3-12
3.4.2.1 Shoreline Management Act; City of Bellingham Shoreline Permit	3-12
3.4.2.2 Major Grading Permit	3-12
3.4.2.3 Critical Areas	3-13
3.4.2.4 Stormwater Requirements	3-13
3.4.3 Other Laws and Regulations	3-13
3.5 COMPLIANCE MONITORING	3-14
3.5.1 Protection Monitoring	3-14
3.5.2 Performance Monitoring	3-15
3.5.3 Confirmation Monitoring	3-16
3.6 INTEGRATION WITH FINAL CLEANUP ACTION AND FUTURE LAND USE	3-16
4.0 USE OF THIS REPORT	4-1
5.0 REFERENCES	5-1

FIGURES

<u>Figure</u>	<u>Title</u>
1	Vicinity Map
2	Current Conditions Site Plan
3	Interim Action Site Plan and Section
4	Soil Cover Thickness
5	Extent of Site Contamination
6	LFG Control System Schematic
7	LFG Control System Typical Section and Detail
8	Phases 1 & 2 – Waterfront District SubArea Plan

TABLE

<u>Table</u>	<u>Title</u>
1	2007 A-Layer Sediment Sample Analytical Results Compared to MTCA Criteria

APPENDIX

<u>Appendix</u>	<u>Title</u>
A	Gate 3 Sediment Physical Properties

ABBREVIATION/ACRONYM LIST

ASTM	American Society for Testing and Materials
BEP	bis(2-Ethylhexyl)phthalate
BGS	below ground surface
BMC	Bellingham Municipal Code
BNSF	Burlington Northern Santa Fe
cement	Type I/II Portland cement
City	City of Bellingham
CKD	cement kiln dust
cm/sec	centimeter per second
CQA	construction quality assurance
DM	dredged material
DMMU	dredged material management unit
DNR	Washington State Department of Natural Resources
Ecology	Washington State Department of Ecology
EIS	environmental impact statement
FA-C	Class C fly ash
FA-F	Class F fly ash
FML	flexible membrane liner
ft	foot
GP	Georgia Pacific West
HDPE	high density polyethylene
H:V	horizontal:vertical
IPA	interim placement area
LFG	landfill gas
LKD	lime kiln dust
MLLW	mean lower low water
MTCA	Model Toxics Control Act
NPDES	National Pollutant Discharge Elimination System
PCBs	polychlorinated biphenyls
pcf	pounds per cubic foot
PLPs	potentially liable parties
Port	Port of Bellingham
RI/FS	remedial investigation/feasibility study
SEPA	State Environmental Policy Act
Site	Cornwall Avenue Landfill Site
SMA	Shoreline Management Act
SMS	Sediment Management Standards
SMP	Shoreline Master Program
SVOCs	semivolatile organic compounds
TBT	tributyl tin
TEQ	toxicity equivalency
USCS	United Soil Classification System
VOCs	volatile organic compounds
yd ³	square yard

1.0 INTRODUCTION

The Port of Bellingham (Port) intends to perform an interim action at the Cornwall Avenue Landfill site (Site) in Bellingham, Washington. The proposed interim action is designed to beneficially reuse sediment from the Port's Gate 3 dredging project as contouring material to establish grades for drainage as part of the final cleanup action at the Site. The placement and capping of the sediment will also allow a significant amount of the stormwater that currently infiltrates and migrates through Site refuse to be redirected such that groundwater contact with refuse is significantly reduced. The interim action will be conducted under an amendment to Agreed Order No. 1778 between the Port and City of Bellingham (City), potentially liable parties (PLPs) under the Washington State Model Toxics Control Act (MTCA), and the Washington State Department of Ecology (Ecology). The interim action will be implemented in advance of selection of the final cleanup action for the Site, and as such, must not foreclose reasonable alternatives for the cleanup action [WAC 173-340-430(3)(b)].

1.1 BASIS FOR INTERIM ACTION

An interim cleanup action partially addresses the cleanup of a site and achieves one of the following purposes [WAC 173-340-430(1)]:

- Reduces the threat to human health and the environment by eliminating or substantially reducing one or more pathways for exposure to a hazardous substance [WAC 173-340-430(1)(a)].
- Corrects a problem that may become substantially worse or cost substantially more to address if the remedial action is delayed [WAC 173-340-430(1)(b)].
- Completes a site hazard assessment, remedial investigation/feasibility study, or designs a cleanup action [WAC 173-340-430(1)(c)].

The proposed interim action will achieve bullets one and two above. The interim action would provide a low permeability cover over about 65 percent of the landfill, limiting infiltration of stormwater through refuse and the resulting discharge of refuse-affected groundwater to Bellingham Bay. It also substantially reduces the cost of the remedy by significantly reducing the volume of fill needed to re-contour the Site for drainage as part of the final cleanup action.

An interim cleanup action must also meet one of the following general requirements [WAC 173-340-430(2)]:

- Achieve cleanup standards for a portion of the site.
- Provide a partial cleanup (clean up hazardous substances from all or part of the site, but not achieve cleanup standards).
- Provide a partial cleanup and not achieve cleanup standards, but provide information on how to achieve cleanup standards.

The proposed interim action will provide a partial cleanup by:

- Providing the material needed to help establish final grades for the drainage, collection, and management of stormwater over a significant portion of the Site.
- Cleaning up hazardous substances by greatly reducing the contact of infiltrated stormwater with refuse, and the resulting discharge of refuse-affected groundwater to Bellingham Bay
- Assisting in establishing Site grades above the elevation needed to address long term sea level rise
- Installing a landfill gas (LFG) collection system over a significant portion of the Site.

1.2 SITE LOCATION

The Site is located at the terminus of Cornwall Avenue adjacent to Bellingham Bay (Figure 1). The Site is bounded by Bellingham Bay, the R.G. Haley cleanup site (FSID 2870; a former wood treating facility), and Burlington Northern Santa Fe Railway Company (BNSF) tracks, as shown on Figure 2. The Site is approximately 16.5 acres in size, including about 3.5 acres of aquatic lands and 13 acres of uplands. All 3.5 acres of the aquatic lands and approximately 8.4 acres of the uplands are owned by Washington State and managed by the Washington State Department of Natural Resources (DNR); DNR is also a Site PLP. Approximately 4.5 acres of the uplands are owned jointly by the Port and the City. The inner harbor line represents the boundary between Port/City-owned land and state-owned land, as shown on Figure 2. The interim action will be conducted on the waterward side of the inner harbor line, as shown on Figure 3.

Presently, the only significant features on the Site consist of a stormwater detention basin constructed in 2005 at the south end of the Site. The Site is largely unpaved, with the exception of an asphalt road in the northeastern portion of the Site and asphalt pavement around the former wood framed building in the northeastern portion of the Site. Current Site features are shown on Figure 2.

1.3 SITE HISTORY

Historically, the majority of the Site consisted of tide flats and subtidal areas of Bellingham Bay. From about 1888 to 1946, the Site was used for sawmill operations, including log storage and wood debris disposal. Between about 1946 and 1965, the Port held the lease on the state-owned portion, and subleased a portion of the Site to the City from 1953 to 1962. During that latter time period, the City used the Site for the disposal of refuse. In 1962, the City entered into a lease with another Port tenant (American Fabricators) and continued landfill operations at the Site until 1965.

From 1971 to 1985, the Site was leased to Georgia Pacific West (GP) by the Port, including sublease of the state-owned portion of the Site. In 1985, GP purchased the privately owned portion of the Site located to the east of the Inner Harbor Line from the Port. GP used the large warehouse building on

the eastern portion of the Site for storage of tissue paper and other products manufactured at its facility on the Whatcom Waterway until it constructed a new tissue warehouse in 2001. GP used the western portion of the Site for log storage, which included creating stacks of logs (“log decks”) many feet high.

In January 2005, the Port repurchased the privately owned property from GP, in conjunction with other waterfront property owned by GP. In December 2005, the City purchased an ownership interest in the privately owned portion of the Site from the Port.

Upon closure in 1965, the landfill was covered with a soil layer varying in thickness between about 2 feet (ft) and greater than 5 ft, as shown on Figure 4. Additionally, the shoreline was protected by various phases of informal slope armoring consisting of a variety of rock, boulders, and broken concrete. Significant shoreline erosion occurred following closure of the landfill, which resulted in exposure of landfill refuse at the surface and redistribution of landfill refuse onto the adjacent beach area. The toe of the refuse fill slope extends out into Bellingham Bay. The estimated extent of refuse in the upland and aquatic portions of the Site are shown on Figure 5.

The Site came to public attention in 1992 when a beachcomber reportedly discovered medical waste (including glass blood vials and plastic syringes) along the beach at the toe of the landfill. This discovery led to Ecology’s initial Site investigation in 1992. On the basis of data collected during the initial Site investigation, Ecology performed a site hazard assessment under the Toxics Cleanup Program in 1992 and ranked the Site a 2 on a scale of 1 to 5, with 1 being the highest priority. A number of environmental investigations have been conducted at the Site, as discussed in Section 2.0. The Site is currently in the reporting phase of the remedial investigation/feasibility study (RI/FS) phase of the MTCA cleanup process.

1.4 REPORT ORGANIZATION

Section 2.0 of this report presents a summary of Site physical and environmental conditions. Section 3.0 presents the interim action. Section 4.0 summarizes the use of this report. Section 5.0 presents the references for this document.

2.0 PHYSICAL AND ENVIRONMENTAL CONDITIONS

A number of environmental and geotechnical investigations have been conducted at or near the Site, and provide the basis for characterizing Site environmental conditions. Geotechnical investigations were conducted within or adjacent to the Site in 1960 (Dames & Moore 1960) and in 1985 (Purnell & Associates 1985). Ecology conducted an initial environmental investigation of the Site in 1992 (Ecology 1992a), which formed the basis for its site hazard assessment (Ecology 1992b). Tetra Tech compiled Site historical information in a report prepared for DNR (Tetra Tech et al. 1995). In 1996, Landau Associates conducted an expanded Site investigation to further evaluate environmental conditions (Landau Associates 1997). The 1996 Landau Associates investigation also presented sediment quality data for sediments collected near the Site in 1996 as part of the Whatcom Waterway RI/FS (Anchor Environmental and Hart Crowser 1999).

A focused RI was conducted in 1998 and 1999 by Landau Associates to better characterize the flow and quality of background groundwater and groundwater seeps. A supplemental RI was performed in 2002 to address data gaps identified in the focused RI. In September 2008, a sediment investigation was conducted by Hart Crowser on behalf of Ecology to further evaluate the extent of refuse and wood debris in the aquatic portion of the Site (Hart Crowser 2009).

Information obtained during these investigations provided the basis for evaluating the physical and environmental conditions present at the Site. A summary of these conditions is presented below.

2.1 SITE PHYSICAL CONDITIONS

The Site is relatively flat, sloping gently downward to the south, with a surface elevation between about 10 and 14 ft above mean lower low water (MLLW). The slopes of the intertidal and shallow subtidal zones (above about -10 ft MLLW) range from between about 5 Horizontal to 1 Vertical (5H:1V) to 10H:1V, and are generally within 100 to 200 ft of Site uplands. The deeper subtidal zone offshore from the Site has a relatively flat slope of about 20H:1V. Recent Site topography is shown on Figure 3 and Site bathymetry is shown on Figure 5.

Site surface and subsurface conditions generally consist of landfill cover and refuse overlying native alluvium and glacial deposits. Two principal hydrogeologic units were identified. The uppermost hydrogeologic unit consists of the landfill refuse, sawdust, wood debris, and other fill materials placed at and near the Site. Underlying this unit are the fine-grained silts and clays of both the glacial marine drift and alluvium deposits, which form an aquitard throughout most of the Site. The depth to groundwater varied between 4 to 10 ft below ground surface (BGS) during the supplemental RI, and the direction of shallow groundwater flow was determined to be generally to the west.

2.2 SITE ENVIRONMENTAL CONDITIONS

Environmental conditions at the Site were generally evaluated by comparing concentrations of constituents detected in Site media of concern to proposed cleanup levels for the Site. However, it was assumed that refuse poses a threat to human health and the environment from direct contact and quantitative analyses of the soil was not conducted during the RI Site investigations.

Proposed cleanup levels were developed for constituents detected in groundwater and sediment. Proposed cleanup levels for groundwater were developed under MTCA based on protection of human health and the environment, assuming that the highest beneficial use for groundwater is discharge to marine surface water. Proposed cleanup levels for sediment were identified using criteria developed under the Sediment Management Standards (SMS) for protection of ecological receptors.

Site contamination consists primarily of soil, groundwater, and sediment impacts resulting from the presence of refuse. Cyanide and ammonia contamination have also been identified in groundwater at several groundwater seep locations at the surface water interface. Other constituents that were detected in groundwater at concentrations exceeding proposed cleanup levels include copper, polychlorinated biphenyls (PCBs), and fecal coliform. The copper exceedances may be related to upgradient water quality conditions. Soil and groundwater in the northeastern corner of the Site are impacted by petroleum hydrocarbons originating from other sources, such as the adjacent R.G. Haley site. The lateral extent of soil and groundwater contamination by dioxins/furans at the R.G. Haley site has not been determined. Such contamination may extend onto the Site.

Sediment constituents of concern at the Site were determined based on exceedance of SMS standards and consist of copper, lead, silver, zinc, PCBs, and bis(2-ethylhexyl)phthalate (BEP).

2.3 GATE 3 SEDIMENT (BENEFICIAL REUSE MATERIAL)

The Port's Gate 3 dredging and float replacement project consists of renovating Floats F & G of the existing Gate 3 dock system in Squalicum Outer Harbor. The project includes harbor maintenance dredging to restore navigable water depths at the marina entrances, within the berthing areas, and along the navigation channels. The project will be conducted under a U.S. Army Corps of Engineers permit and will remove up to 40,800 cubic yards (yd³) of dredged material, depending on how many of the dredged material management units (DMMUs) are dredged for the project. The placement of the dredge material at the Cornwall Avenue Landfill Site is a component of the Joint Aquatic Resources Permit Application submitted to the U.S. Army Corps of Engineers and will be subject to the requirements of the project permit.

The number of DMMUs that will be dredged is dependent on the project bidding. If the successful bid allows for a cost-effective approach, all three DMMUs will be dredged for a total of about 40,800 yd³. However, if the successful bid is too high, only DMMUs POB 1 and POB 2 will be dredged, which would result in a total material volume of about 24,900 yd³. As a result, the volume of sediment to be placed at the Site will not be determined until bidding for the Gate 3 project is complete.

2.3.1 GATE 3 SEDIMENT PHYSICAL PROPERTIES

The physical properties of the Gate 3 sediment were evaluated to determine how the material will perform as a contouring material and as a component of a capping system for the Site, if capping were to be chosen as part of the final cleanup remedy following culmination of the RI/FS process for the Site. Additionally, bench scale testing was conducted to estimate the amount of admixture that might be required to adequately moisture condition the sediment for placement and compaction. Physical testing included:

- Grain size distribution conducted as part of sediment characterization activities
- Atterberg limits to supplement the grain size distribution test results to confirm the soil type based on the Unified Soil Classification System (USCS)
- Natural moisture content to estimate the moisture content of the dredged material after initial dewatering but prior to drying or amendment
- Moisture-density relationships (Standard Proctor compaction test) to determine the moisture content range required for the sediment to be sufficiently moisture conditioned for placement, grading, and compaction
- Hydraulic conductivity of the sediment in a moisture-conditioned state to estimate the hydraulic properties of the sediment following placement and compaction
- Sediment stabilization testing to estimate the amount of an absorbent material (such as cement, fly ash, etc.) that would likely be required to adequately moisture condition the sediment for placement, grading, and compaction.

These tests provide the information necessary to establish the requirements for modifying the dredged sediment from a wet, soft material to a workable soil appropriate for use as a contouring fill material on the Site. Although the contractor will have the option of proposing alternative means for moisture conditioning the dredged sediment, the use of absorbent admixtures to stabilize and moisture condition soil is a demonstrated technology that has been successfully used on numerous projects to stabilize moisture-sensitive soil and sediment. The results of the stabilization testing also helps establish the baseline moisture conditioning requirements that the contractor will need to achieve prior to placement and compaction of the dredged material on the Site.

The results of the sediment stabilization test program demonstrate that the soft, wet sediment to be dredged as part of the Port's Gate 3 project can be processed and moisture conditioned by mixing with

common pozzolan materials to produce a beneficial reuse material with a friable, soil-like consistency that will allow for subsequent placement and compaction as low permeability fill material at the Site. The results of the hydraulic conductivity testing indicate that once properly moisture conditioned and compacted, the beneficial reuse material exhibits a low permeability that will impede the infiltration of water. Appendix A should be reviewed for a detailed discussion of the testing program and results.

2.3.2 GATE 3 SEDIMENT QUALITY

The Gate 3 sediment was tested for total metals, tributyl tin (TBT), volatile organic compounds (VOCs), semivolatile organic compounds (SVOCs), pesticides, PCBs, and dioxins/furans. Dioxin concentrations for Gate 3 sediment planned for dredging ranged from 6.2 to 27.3 nanograms/kilogram (ng/kg) [2,3,7,8 TCDD toxicity equivalency (TEQ)] in the initial testing conducted using EPA Method 8290 for dioxins/furans analysis, as shown in Table 1. Follow-up dioxins/furans testing was conducted for composite and discrete core samples from DMMU POB 1 and POB 2 using a different analytical method (EPA Method 1613B) to confirm the original results. The dioxin TEQ concentrations for the follow-up analyses of the composite samples were 22.4 ng/kg and 9.6 ng/kg for DMMUs POB 1 and POB 2, respectively, which are slightly higher than, but consistent with, the original analyses using EPA Method 8290. The sediment characterization report for the Gate 3 project (Landau Associates 2010) should be reviewed for a more detailed discussion of sediment quality analyses conducted for the Gate 3 project, including dioxins/furans.

Gate 3 sediment quality was compared to proposed soil cleanup levels to evaluate the potential for beneficial reuse of the Gate 3 sediment to affect Site environmental conditions. Because the Gate 3 sediment will be contained under a low permeability cap in conjunction with affected Site media, is itself a low permeability material, and will not be in constant contact with Site groundwater (see Section 3.2.4), protection of groundwater quality is not considered a complete migration pathway. As a result, MTCA Method B cleanup levels based on direct contact for unrestricted land use are the proposed levels to evaluate the potential impacts of Gate 3 sediment on Site environmental conditions. (Method C cleanup levels based on direct contact for industrial land use also are presented in Table 1 for the purpose of providing additional information.)

As shown in Table 1, the sediment sample for DMMU POB 3 exceeded the proposed soil cleanup level for dioxins/furans but was well below the MTCA Method C cleanup level. Similarly, the follow-up analysis of DMMU POB 1 using EPA Method 1613B exceeded the proposed soil cleanup level for dioxins/furans, but was also well below the Method C cleanup level. Onsite containment of hazardous substances above cleanup levels can be a valid cleanup action component if the requirements of MTCA are met. Based on these considerations, Gate 3 sediment is considered appropriate for beneficial reuse at

the Site, provided dioxins/furans or other contaminants are prevented from leaching into groundwater, provided sediment is properly capped, and provided the cap integrity is ensured through institutional controls.

3.0 INTERIM ACTION

This section presents a summary of the evaluation and selection of the interim action planned for the Site. This section is organized into the following subsections: Purpose of the Interim Action (Section 3.1), Description of Interim Action (Section 3.2), Permitting (Section 3.3), and Compliance Monitoring (Section 3.4).

3.1 PURPOSE OF THE INTERIM ACTION

The purpose of the interim action is to beneficially reuse sediment from the Gate 3 project to establish grades that promote drainage at the Site for the collection and conveyance of stormwater, and to raise Site grades to support future land use and address anticipated long-term sea level rise. The placement and capping of the sediment will also allow a significant amount of the stormwater that currently infiltrates and migrates through Site refuse to be redirected such that groundwater contact with refuse is significantly reduced. Additionally, hydraulic conductivity testing indicates that the material would function as a low permeability layer of a composite low permeability capping system (if such a capping system is part of the final cleanup action for the Site), which would increase the overall effectiveness and reliability of the final cleanup action. The interim action also includes the installation of a LFG collection system beneath the interim action area.

The interim action will occur in the area shown on Figure 3, which covers about 4.5 acres. The beneficial reuse material will be placed up to 15 ft high for the interim action to minimize the footprint of the interim action area and to provide adequate access for regrading and recompaction of the material during construction of the final cleanup action. It is anticipated that the beneficial reuse material will be regraded to a thickness of between about 3 or 6 ft for the final cleanup action depending on the actual dredge volume, although the specific grades and elevations will be determined during design of the final cleanup action. The interim action will consist of the following elements:

- Sediment will be moisture conditioned/stabilized prior to placement at the Site, which will eliminate any free water in sediment prior to placement.
- A perimeter berm and roadway will be constructed around the interim area from existing cover soil
- A landfill gas collection system will be installed beneath the interim action area prior to sediment placement.
- Sediment will be graded for stormwater drainage to the existing stormwater basins to provide interim stormwater management.
- A temporary cap with scrim-reinforced plastic, or similar material, will be placed over the graded beneficial reuse material to prevent erosion and allow stormwater to be managed as noncontact stormwater.

3.2 DESCRIPTION OF INTERIM ACTION

As described in Section 2.3, the Gate 3 project will remove between 24,900 and 40,800 yd³ of dredged material, depending on how many of the DMMUs are dredged for the project. Because the number of DMMUs that will be dredged, and the associated dredge volume, is dependent on cost of the successful bid, the size of the interim placement area (IPA) and/or the height of sediment within the IPA will not be finalized until shortly before construction starts. As a result, the interim action design needs to be sufficiently flexible to accommodate this uncertainty in dredge volume.

Figure 3 shows the preliminary layout for the IPAs. The primary IPA is located at the south end of the interim action area. This area (IPA-1) will be used for placement of the moisture-conditioned dredged sediment from DMMUs POB 1 and POB 2. A second interim placement area (IPA-2) is located to the north of IPA-1 and will be used for placement of dredged sediment from DMMU POB 3, if this DMMU is dredged. If DMMU POB 3 is not dredged, the material from DMMUs POB 1 and POB 2 may be spread out over both IPA areas for ease of placement and future re-grading for the final cleanup action.

3.2.1 GRADING AND CAPPING

The preliminary interim action design anticipates that moisture-conditioned dredged sediment will be transported from a processing area at the GP site and placed within the IPAs. The dredged material will be end-dumped and consolidated into one or two contiguous IPAs up to approximately 15 ft in height to provide sufficient access around the IPA areas for construction of stormwater controls and equipment operation. Because material placement is anticipated to occur during high precipitation months associated with the dredging “fish window” (November through February), the dredged material will be covered directly following placement to maintain its moisture-conditioned state. The dredged material will be graded for drainage and the installation of the low permeability cover.

The moisture-conditioned sediment will be covered with a minimum 12 mil scrim-reinforced polyethylene liner material, or equivalent. It will be necessary to maintain the dredged material in a secured condition protected from the elements until the final cleanup action is designed. As a result, a temporary liner material that has a 4 to 5 year life will be selected for the IPA cover system. The portion of the Site that will be covered by the liner system is shown on Figure 6.

Because the dredged material is moisture sensitive, the material will be progressively covered during placement in the IPA to limit contact with precipitation. Once placed, the dredged material will be covered on a daily basis during periods of active or anticipated precipitation. The liner will be seamed to provide a continuous cover over the dredged material and secured by sandbags. The IPAs will be maintained in this condition until the dredged material is regraded and compacted as part of the final cleanup action. A cross sectional view of IPA-1 is shown on Figure 3.

As discussed in Section 2.2, petroleum hydrocarbon contamination associated with releases from other sources, such as the R. G. Haley site, is present in the northeastern corner of the Site. As shown on Figure 6, the interim action area is configured so that IPA-2 does not extend over the petroleum hydrocarbon contamination area to ensure that the interim action will not preclude the final cleanup action selected for the R. G. Haley site.

3.2.2 STORMWATER MANAGEMENT

Stormwater will be managed to prevent contact with, and erosion of, the dredged material, and to reduce surface water infiltration through refuse. A soil berm will be constructed on the shore side of the interim action area and a drainage ditch will be constructed around the perimeter of the area. Plan and section views of these features are presented on Figure 3.

It is anticipated that existing Site cover soil will be used to construct the berm which will prevent the direct discharge of stormwater, and any suspended solids that are entrained in stormwater, to Bellingham Bay. Because the primary purpose of the berm is to control stormwater rather than to contain the dredged sediment, it will only need to be about 2 to 4 ft high. Based on available exploration logs, the existing cover soil is between about 2 ft and 4 ft thick and varies in composition from ballast rock to silty sand with gravel. It will require about 12 inches of the existing cover soil from the interim action area to construct the access roads and berm, leaving at least 1 ft of cover over the refuse.

The dredged material will be graded to drain toward a drainage ditch that will be created around the perimeter of the interim action area. The drainage ditch and the access roads surrounding the IPAs will be lined with the same liner material used to cover the dredged material, as illustrated in the section view on Figure 3. Lining of the drainage ditch will prevent soil erosion and stormwater infiltration through the refuse. Collected stormwater will be routed to the existing stormwater basins located at the south end of the Site.

About 70 percent of the stormwater runoff from the IPAs will be routed to the existing stormwater basins. The existing stormwater basins are large enough to hold the runoff from the interim action area for a 2-year, 24-hour storm event. Stormwater in excess of this amount will overflow and infiltrate in the area around the pond as well as flow over the riprap sill at the south end of the stormwater basins and discharge to Bellingham Bay. Due to Site grades, the stormwater from the shore side and southern end of the south IPA, which represents about 30 percent of the interim action area, will drain directly to the riprap sill on the outlet side of the conveyance pond system and will flow across the riprap sill to the bay. The combination of 1) stormwater from the southern portion of the interim action area that will directly discharge to the bay and 2) stormwater from larger storm events that exceed the retention capacity of the existing stormwater basins and will discharge to the bay represent more than 30 percent of

the stormwater that currently infiltrates through refuse into Site groundwater. The direction of stormwater routing within the drainage ditches is illustrated by arrows on Figure 3.

The interception and routing of stormwater from the IPAs will reduce contact between groundwater and refuse and thus improve the quality of Site groundwater discharging to Bellingham Bay. This will be accomplished by discharging stormwater directly to Bellingham Bay, which reduces the amount of groundwater originating from the Site, and reducing the contact between groundwater and refuse that does infiltrate on the Site. The reduction in contact will result from preventing the direct infiltration of stormwater through refuse over about 65 percent of the landfill area and conveying the intercepted stormwater to the existing stormwater basins located outside the refuse area.

Of the stormwater that does infiltrate to groundwater in the basins, a portion will not contact refuse prior to discharging to Bellingham Bay because of the location of the basins relative to the landfill and the shoreline. The reduction of stormwater infiltration through refuse and the associated reduction of Site groundwater discharge to Bellingham Bay are anticipated to be primary goals for the final Site cleanup action. As such, the interim action represents the first phase of groundwater remediation that is anticipated to be a key component of the final cleanup action.

3.2.3 LFG CONTROL

Because the Cornwall Avenue Landfill last accepted refuse more than 40 years ago, the rate of refuse decomposition and methane gas generation likely will have followed the typical gas generation curve, which would mean gas generation has decreased to minimal levels in recent years. However, the placement of a low permeability material such as the dredged material over the existing soil cover will prevent ongoing methane generation from directly venting vertically to the atmosphere. As a result, methane gas generated by ongoing decomposition would migrate laterally until it was able to vent vertically beyond the limits of the IPA. There are no existing structures on or near the Site where methane gas could accumulate and pose a potential health or explosion risk. As a result, the risk of methane gas migrating a sufficient distance laterally from beneath the IPAs to enter a habitable structure and pose a risk to human health is minimal.

Although the risk posed by methane gas migration resulting from implementation of the interim action is considered minimal, there are logistical considerations that support the installation of a LFG control system as part of the interim action. Although the dredged material could be graded and compacted to its final configuration at a later date, it would not likely be stripped down to the current landfill surface. As a result, installation of the LFG control system as part of final design would require trenching through the dredged material and replacing and compacting the material following installation of the LFG collection lines. Because of the fine-grained nature of the material, it is more difficult to

properly compact the sediment within the confines of a trench excavation rather than as a contiguous layer. Improperly compacted trench backfill would result in breaches to the continuity of the compacted dredged material layer that could allow landfill gas buildup beneath the overlying flexible membrane liner (FML) cap that will be constructed as part of final cleanup. Additionally, landfill gas could build up beneath the sediment and be released during trenching for the LFG system, which would pose a risk to worker health and safety.

Based on these considerations, a LFG control system will be installed beneath the interim action area in conjunction with dredged material placement. The preliminary configuration of the LFG control system is shown on Figure 6, although the location and spacing of the LFG system laterals may be modified during detailed design. The system will be constructed using strip geocomposite materials that consist of prefabricated core material wrapped with a nonwoven geotextile. The strip geocomposite material is flexible and can accommodate a significant amount of total and differential settlement, although extensive settlement is not anticipated due to previous loading of the area by the former log decking operations.

The LFG system is currently designed to passively vent at the north and south terminus of the main vent line; however, this may be modified during design. The LFG system will be designed so it can be integrated into the LFG system for the final cleanup action, and will be capable of being used as a component of either a passive or active LFG system incorporated into the final cleanup action for the Site. Figure 7 provides LFG system details, including a typical section through the LFG collection line and a section view of a LFG system vent riser.

3.2.4 SEA LEVEL RISE

Several studies have been conducted to predict sea level rise in the Pacific Northwest due to climate change (global warming). The results of these studies have been summarized in the Port's draft and final environmental impact statement (EIS) for The Waterfront District Redevelopment Project (formerly known as New Whatcom) (Blumen 2010), which includes the Site. According to the EIS, a 2006 study estimates that sea level rise in the Puget Sound Basin may range between 6 and 50 inches with a median estimate of 13 inches by 2100 (Ecology and CTED 2006). To analyze impacts of the redevelopment project on the environment, the EIS used a sea level rise of 2.4 ft by 2100, which was adopted for evaluating the impacts of sea level rise for the interim action.

The highest estimated tide for Bellingham is 11.5 ft +/- 0.5 ft above Mean Lower Low Water (MLLW; USACE 2011). Additional analysis will be required during the design of the final cleanup action to determine the minimum ground surface elevation needed for the long term performance of the cleanup action. However, it is reasonable to assume for preliminary evaluation purposes that final Site

elevations should be at least 2 ft above extreme high water. Assuming an extreme high water elevation of 12 ft MLLW and a 2.4 ft sea level rise by 2100, the final Site ground surface elevation should be at least 16.4 ft MLLW. Site upland grades currently range from about 10 ft to 14 ft MLLW, or about 2.4 to 6.4 ft below the estimated minimum elevation for Site finish grades. As a result, the beneficial reuse of the Gate 3 sediment to raise Site grades by 3 to 6 ft is consistent with anticipated long term sea level rise. Detailed design of final grades will be addressed as part of the final cleanup in conjunction with land use planning efforts

In addition to the final ground surface elevation, the potential for dredged material to come into contact with groundwater as a result of sea level rise was considered in the evaluation of interim action performance. There is a potential that sediment subjected to prolonged contact with groundwater could leach contaminants (i.e., dioxins/furans) to groundwater. Prolonged contact could occur either through a general rise in groundwater levels or through tidally caused inundation near the shoreline. Short-term contact between groundwater and dredged sediment is not considered a significant risk because the low solubility of dioxin limits its leachability, and the low permeability of the dredged material limits the infiltration of groundwater into the dredged sediment, during short periods of contact.

Groundwater elevations currently range between about 3.5 ft and 8 ft below the ground surface within the interim action area based on available groundwater monitoring data. As discussed in Section 3.2.2, the interim action will reduce infiltration of stormwater over 65 percent of the landfill area. If the final cleanup action includes a low permeability cover over the remainder of the Site, these actions will reduce stormwater infiltration, resulting in at least a 50 percent reduction in groundwater flow at the Site, which will significantly lower groundwater levels from their current elevations. The impact of the reduction of infiltration on groundwater elevations due to Site capping is expected to more than offset any general long-term increase in groundwater levels that result from sea level rise. As a result, the existing 3.5 ft to 8 ft unsaturated zone provides an adequate buffer against inundation of the dredged material by a general rise in groundwater elevations due to an assumed sea level rise of 2.4 ft, even if up to 1 ft of the current landfill cover soil is used to construct berms and haul roads for the interim action.

The mean high water elevation (MHW), which is the average of all high water elevations for a given location, was used as a conservative basis for evaluating the potential for prolonged contact between dredged sediment and groundwater in the shoreline vicinity due to tidal impacts. MHW represents a water elevation that would on average occur twice a day. However, the impact of tidal fluctuation dissipates rapidly in groundwater moving inland from the shoreline. Groundwater elevation data collected at the Site indicate that a tidal fluctuation of about 8 ft results in only about a 0.3 ft change in groundwater elevation 20 ft from the shoreline. Consequently, the dredged material, which will not be placed within 20 ft of the shoreline, would not come into even short term contact with tidally influenced

groundwater if maintained at an elevation greater than MHW. The current MHW elevation for Bellingham Bay is 7.7 ft above MLLW. Based on the assumed long term sea level rise of 2.4 ft, MHW in future would be 10.1 ft above MLLW. As a result, dredged sediment is considered protected from tidally influenced groundwater inundation if it is maintained above a current elevation of 10 ft MLLW.

As indicated in Section 2.1, Site grades in the interim action area generally range between 10 ft and 14 ft MLLW, with the lower elevations present in the southern portion of the Site. Based on the forgoing evaluation, the interim action is adequately protected from sea level rise, but existing ground surface elevations in the southern portion of the interim action area are too low for material from this area to be used for construction of berms and haul roads. As a result, use of onsite cover soil for the construction of berms and haul roads will be limited to areas with elevations greater than 11 ft MLLW, and grading will not extend below an elevation of 10 ft MLLW. If needed, clean material will be imported to the Site to construct the berms.

3.2.5 OVERWATER WALKWAY

The City is planning to construct an overwater walkway between Boulevard Park to the south and the southwest corner of the Site. As shown on Figure 3, the overwater walkway would likely terminate within the outer access roadway and berm for the interim action. The elevation of the walkway landing is currently planned at 16.8 ft MLLW, which is about 6 ft to 7 ft higher than the existing ground surface in this area. Consequently, significant filling will be required in this area to achieve finish grades in the vicinity of the overwater walkway, indicating that the interim action is consistent with the final grades needed to support completion of the overwater walkway landing. Additionally, the landing terminates about 50 ft outside of the footprint for the southern IPA, so a sufficient buffer is present between the southern IPA and the overwater walkway landing to allow for the construction of a temporary terminus to the landing if it is completed prior to implementation of the final cleanup action. The Port and the City will continue to coordinate design and planning efforts to ensure that the interim action does not interfere with the landing of the proposed overwater walkway.

3.2.6 CONSTRUCTION TIMING

Construction bidding is anticipated to commence in June 2011 and be concluded in July 2011, and contractor notice to proceed will occur in August 2011. Project construction is expected to take up to 6 months, commencing in September 2011 and concluding in February 2012.

3.3 EVALUATION OF DIOXIN MOBILITY

There are a number of physical and chemical considerations that indicate that the mobilization of dioxin, which is present in the beneficial reuse material at relatively low levels, would not be expected, including the Site-specific conditions and capping components associated with the interim action, the physical characteristics of the beneficial reuse material, and the chemical characteristics of dioxins/furans. Two potential mechanisms exist for dioxins/furans to be mobilized following implementation of the interim action. Dioxins/furans could potentially be mobilized by precipitation infiltrating through the low permeability cap and leaching dioxins/furans from the beneficial reuse material, and the leachate entering the groundwater flow system and discharging to surface water. A potential second mechanism would be for groundwater levels to increase sufficiently due to sea level rise to inundate the beneficial reuse material and leach dioxins/furans to groundwater, which would then discharge to surface water.

The following sections discuss dioxin concentrations relative to MTCA cleanup levels for potential migration pathways associated with the proposed interim action. This evaluation is intended to demonstrate the protectiveness of the proposed interim action, and not to develop Site cleanup levels. Site cleanup levels for all impacted media and pathways will be established by Ecology in the cleanup action plan following completion of the RI/FS.

3.3.1 INFILTRATION PATHWAY

The potential for dioxins/furans to leach to groundwater due to infiltration of precipitation through the low permeability cap was evaluated using the MTCA three phase partitioning model [WAC 1730340-747(5)] to estimate the dioxins/furans soil concentration that is protective of groundwater and comparing it to the soil concentrations present in the beneficial reuse material. The three phase model includes the application of a dilution factor (DF) to account for the reduction in concentration that occurs as water infiltrates through the vadose zone and enters the aquifer. The default dilution factor is 20 for unsaturated soil. However, the capping of the soil increases the effective DF by dramatically reducing the amount of precipitation that infiltrates through the affected media and enters the groundwater flow system. As a result, the MTCA regulations allow a site-specific DF to be used in evaluating the protectiveness of a remedy such as a cap [WAC 173-340-747(5)(f)(ii)(B)].

A high density polyethylene (HDPE) cap is typically considered to be at least 90 to 95 percent effective in reducing infiltration. Taking into consideration the low hydraulic conductivity of the beneficial reuse material, 4×10^{-8} cm/sec (presented in Appendix A), the combination of the HDPE and the beneficial reuse material is anticipated to be at least 98 percent effective in reducing infiltration. Using this infiltration reduction, in conjunction with the estimates of groundwater flow rate and

precipitation from Site remedial investigation activities, a Site-specific DF of 264 was calculated using Equation 747-3 in the MTCA regulations.

Using marine aquatic water quality criteria based on human consumption of fish (5.1×10^{-9} ug/L) as the target groundwater concentration, the calculated soil concentration of dioxins/furans in the beneficial reuse material that would be protective of groundwater is 51 ng/kg (ppt) using the Site-specific DF. This soil concentration is about twice the highest concentration measured in the beneficial reuse material, which demonstrates that the interim action will be adequately protective of human health and the environment against leaching of dioxins from the beneficial reuse material due to infiltration.

To establish a baseline for anticipated dioxins/furans concentration in groundwater, the estimated impact of background soil concentration of dioxins/furans in soil on groundwater quality was determined and compared to the estimated impact of the interim action. Ecology estimates that the background soil concentration of dioxins/furans for Washington State is 5.2 ng/kg. The MTCA formula for calculating Method B soil cleanup levels for protection of groundwater was used to estimate the groundwater concentration resulting from this background concentration of dioxins/furans in soil and from the interim action. The estimated groundwater concentration resulting from the infiltration of precipitation through soil containing background concentrations of dioxins/furans is 9.6×10^{-9} ug/L. The estimated groundwater concentration resulting from infiltration of precipitation through the capped beneficial reuse material is 2.1×10^{-9} ug/L. Based on these results, the estimated impact of the interim action on Site groundwater dioxins/furans concentrations is more than four times lower than the impact of the State background dioxins/furans concentration on groundwater. In summary, the potential for leaching of dioxins at this Site will be less than that from natural soil used as construction material in Washington State due to the covering of the material at this Site.

3.3.2 INUNDATION PATHWAY

As discussed in Section 3.2.4, it is not anticipated that the beneficial reuse material would come into prolonged contact with groundwater due to inundation by either tidal influences or long-term sea level rise. However, due to the uncertainty in the magnitude of long-term sea level rise, the potential impact of inundation of the beneficial reuse material due to long-term sea level rise on groundwater quality was evaluated. The intent of this evaluation was to determine whether inundation would impact groundwater quality to the degree that dioxins/furans in groundwater would potentially migrate to surface water at concentrations that would pose a risk to human health or the environment.

It is well established that dioxins/furans partition heavily to soil. The degree of partitioning is largely controlled by the organic carbon content of the aquifer matrix. Landfills contain a very large amount of organic carbon, which will cause even greater partitioning to the aquifer matrix than occurs in

most aquifer matrices. References indicate that 35 to 45 percent of landfill contents are carbon. Assuming an organic carbon content of 20 percent (well below the typical range of 35 to 45 percent), and assuming a DF of 20 to reflect the limited flow that would occur through the beneficial reuse material due to its low permeability characteristics, the dioxins/furans soil concentration calculated to be protective of the groundwater to surface water pathway for the Site would be 55 ng/kg based on the MTCA 3-phase model, or about twice the maximum concentration measured in the beneficial reuse material. Based on this evaluation, even in the unlikely event that the beneficial reuse material was inundated continuously, the dioxins/furans concentrations leaching to groundwater would not be sufficiently elevated to adversely affect surface water quality.

3.3.3 MEASUREMENT OF DIOXINS/FURANS CONCENTRATIONS IN GROUNDWATER

The foregoing discussion of the impacts of the interim action on Site groundwater quality is based on risk-based water quality criteria. However, these criteria are significantly lower than the laboratory analytical methods available for testing dioxins/furans in groundwater or surface water. Although dioxins/furans reporting limits vary somewhat by analytical method, a reporting limit of 0.5 ng/L is on the lower end of reporting limits available from commercial analytical laboratories. The risk-based water quality criteria used above to demonstrate that the interim action is adequately protective of groundwater quality (5.1×10^{-9} ug/L) is about 100,000 times lower than the laboratory reporting limits for dioxins/furans in water. Thus, while the evaluations above demonstrate that the interim action would be adequately protective of groundwater and surface water quality, dioxins/furans groundwater quality monitoring for evaluating the performance of the interim action is problematic due to the limitations of laboratory analytical methods (see Section 3.5 for discussion of compliance monitoring).

3.4 APPLICABLE, RELEVANT, AND APPROPRIATE REGULATORY REQUIREMENTS

This interim action will be conducted under Agreed Order No. 1778, as amended, with Ecology. The amended Agreed Order requires identification of the permits or specific federal, state, or local requirements that the agency has determined are applicable and that are known at the time of entry of this Order. The Interim Action is exempt from the procedural requirements of Chapters 70.94, 70.95, 70.105, 77.55, 90.48, and 90.58 RCW and of any laws requiring or authorizing local government permits or approvals, but must still comply with the substantive requirements of such permits or approvals. The amended Agreed Order also requires the exempt permits or approvals and the applicable substantive requirements of those permits or approvals, as they are known at the time of entry of this Order, be identified.

3.4.1 PERMITS AND OTHER REQUIREMENTS

Permits or specific federal, state or local requirements that are applicable to this interim action and that are known at this time are identified as follows:

3.4.1.1 NPDES Construction Stormwater General Permit

A National Pollution Discharge Elimination System (NPDES) Construction Stormwater General Permit will be required for this Interim Action. Ecology administers the federal NPDES regulations in Washington State. All construction projects that disturb more than 1 acre during construction obtain a NPDES construction stormwater permit. The NPDES permit program is delegated to Washington State by the federal Environmental Protection Agency under the federal Clean Water Act, § 1251 et seq. Pursuant to RCW 70.105D.090(2), the agency has determined that the procedural requirements of the NPDES permit are not exempt. The Port will acquire and comply with the requirements of an NPDES construction stormwater permit issued separately by Ecology. Monitoring requirements will be determined as a component of the stormwater permit, and will likely include turbidity monitoring which can often serve as a surrogate for other water quality constituents of concern because the major transport mechanism for stormwater contaminants is associated with erosion of soil particles. Therefore, monitoring for additional surface water contaminants will not be required for the interim action.

3.4.1.2 State Environmental Policy Act (SEPA)

Compliance with SEPA, Chapter 43.21C RCW, will be achieved by conducting SEPA review in accordance with applicable regulatory requirements, including WAC 197-11-268, and Ecology guidance as presented in Ecology Policy 130A (Ecology 2004). SEPA review will be conducted concurrent with public review of the interim action. The Port will act as the SEPA lead agency and will coordinate SEPA review. It is planned that public review for the interim action plan and associated Agreed Order amendment will be conducted by Ecology concurrently with public review for the SEPA documentation. The Port will coordinate closely with Ecology to ensure that the two public review processes are consistent and concurrent.

Aside from the Ecology administered NPDES Permit, no other federal permits will be required because the interim action will be limited to the upland portion of the Site and not include any in-water work. Additionally, no historic or cultural resources are anticipated to be present within the interim action area that would be subject to protection under local, state, or federal laws. There are no structures remaining on the Site, so potential historic resources are not present. Based on the cultural resources evaluation conducted for the Waterfront District Redevelopment Project EIS (Blumen 2010), the potential

for Native American archeological materials to be present in the interim action area is low. Additionally, the interim action will not include any intrusive activities, so any archeological materials that were present would not be disturbed.

3.4.2 PERMIT EXEMPTIONS AND APPLICABLE SUBSTANTIVE REQUIREMENTS

The following state and local requirements have been identified as applicable but procedurally exempt to this interim action:

- Shoreline Management Act (SMA), RCW 90.58; City of Bellingham Shoreline Permit.
- Major Grading Permit; City of Bellingham Grading Ordinance.
- Critical Areas Permit; City of Bellingham Critical Areas Ordinance, BMC 16.55.
- City of Bellingham Stormwater Requirements, BMC 15.42.

The manner in which the interim action will meet the substantive requirements for these laws and regulations is addressed in the following sections.

3.4.2.1 Shoreline Management Act; City of Bellingham Shoreline Permit

The Shoreline Management Act is implemented through the City of Bellingham Shoreline Management Master Program (SMP). To comply with the SMP, the project must have no unreasonable adverse effects on the environment or other uses, no interference with public use of public shorelines, compatibility with surroundings, and no contradiction of purpose and intent of SMP designation. The interim action has been determined to meet the conditions of the Urban Maritime shoreline designation and is consistent with the SMP.

3.4.2.2 Major Grading Permit

Pursuant to the City of Bellingham Grading Ordinance (BMC 16.70), a Major Grading permit is required from the City for grading projects that involve more than 500 cubic yards of grading. The City grading ordinance identifies a number of standards and requirements for obtaining a grading permit. The City standards and requirements will be integrated into the construction plans and specification for the interim action to ensure that the interim action complies with the substantive requirements of the City grading ordinance. Those substantive requirements include: staking and flagging property corners and lines when near adjacent property, location and protection of potential underground hazards, proper vehicle access point to prevent transport of soil off site, erosion control, work hours and methods compatible with weather conditions and surrounding property uses, prevention of damage or nuisance, maintaining a safe and stable work site, compliance with noise ordinances and zoning provisions,

development of a traffic plan when utilizing City streets, and written permission for grading from legal property owner.

3.4.2.3 Critical Areas

City of Bellingham critical area substantive requirements are applied to activities taking place on shorelines through shoreline permitting. The Interim Action will occur on land designated as “seismic” and “erosion” hazard areas by BMC 16.55 Critical Areas. The substantive requirements include an assessment or characterization of the hazard areas, a hazard analysis, and a geotechnical engineering report by a licensed professional.

3.4.2.4 Stormwater Requirements

Pursuant to the City of Bellingham Stormwater Management (BMC 15.42), the Interim Action must meet the requirements of a City Stormwater Permit. The substantive requirements include preparation of a stormwater site plan, preparation of a construction stormwater pollution prevention plan, source control of pollution, preservation of natural drainage systems and outfalls, onsite stormwater management, runoff treatment, flow control, and system operations and maintenance.

3.4.3 OTHER LAWS AND REGULATIONS

Pursuant to WAC 173-350-020(8)(a), state solid waste handling regulations do not apply because the dredged material is subject to the requirements of a Clean Water Act Section 404 permit issued by the U.S. Army Corps of Engineers.

In addition, the activities to be performed as part of the proposed interim action are not regulated under the Washington Clean Air Act (Chapter 70.94 RCW and WAC 173-400-100), and the interim action is not expected to create conditions that would significantly affect the ambient air quality or to cause any exceedance of applicable air quality standards. The Gate 3 sediment does not contain volatile organic compounds that could create an air quality concern during placement at the Site. The sediment will be placed during the wet season at a moisture content wet of optimum, so the release of particulates (dust) to the air is anticipated to be minimal, although will be monitored as described in Section 3.4.1. As described in Section 3.4.1, hydrogen sulfide (H₂S,) may be released to the atmosphere by the dredged sediment and will be monitored for at the offloading facility to address potential worker health and odor concerns. However, H₂S emission levels are not anticipated to be more significant than any sediment dredging project in Bellingham Bay and are not anticipated to cause a significant or long-term air quality issue. Although landfill gas is proposed to be collected and released to the atmosphere via a future LFG

system, the net discharge of LFG will remain unchanged during the implementation of the interim action. It is expected that the interim action will cause no net increase in LFG emissions to the atmosphere.

3.5 COMPLIANCE MONITORING

Compliance monitoring needs to address three important elements to assure the effectiveness of the interim action: 1) protection of human health and the environment during cleanup activities, 2) performance of the interim action in meeting cleanup standards, and 3) confirmation of the long-term effectiveness of the interim action. MTCA requires compliance monitoring for all cleanup actions, including interim actions, as described in WAC 173-340-410. Compliance monitoring is conducted for the following three purposes, which are discussed further in the following sections:

- **Protection monitoring** to confirm that human health and the environment are adequately protected during construction, operation, and maintenance associated with the cleanup action.
- **Performance monitoring** to confirm that the cleanup action has attained cleanup standards and any other performance standards.
- **Confirmational monitoring** to confirm the long-term effectiveness of the cleanup action once the cleanup standards and other performance standards have been attained.

3.5.1 PROTECTION MONITORING

Protection monitoring will address worker health and safety for activities related to construction of the interim action, as well as protection of the general public. Worker health and safety will be addressed through a project health and safety plan (HASP). The requirements for a project HASP will be included in the project construction documents, and the contractor will prepare the HASP. The HASP will address potential physical and chemical hazards associated with Site activities consistent with the requirements of WAC 173-340-810, and field monitoring to confirm that potential exposure to chemical hazards do not exceed health-based limits. Anticipated potential physical hazards include working in proximity to heavy equipment, heat stress or cold stress, and vehicular traffic. Anticipated potential chemical hazards include exposure to site contaminants through various exposure pathways (i.e., direct contact, inhalation, and ingestion).

Because the interim action will largely be implemented during the wet season, chemical exposure through inhalation of dust is not anticipated to be an issue. However, dust monitoring will be conducted if visible levels of dust are created during construction, including sediment moisture conditioning activities. Dredged sediment often contains H₂S, which represents a potential inhalation health risk and odor issue, although the potential for H₂S issues to occur is no greater than for any dredging project in the Bellingham Bay area. Air monitoring will be conducted for H₂S at the GP site, where release of H₂S

would most likely occur during sediment off-loading and moisture-conditioning. Additional monitoring and/or mitigation measures would be undertaken if H₂S concentrations or odors are determined to exceed acceptable levels. It is anticipated that the health and safety measures implemented to protect worker safely will also adequately protect the general public.

3.5.2 PERFORMANCE MONITORING

Performance monitoring typically consists of testing samples of affected media (soil, groundwater, sediment) to determine that the cleanup action has achieved cleanup standards. However, this interim action does not include actions intended to achieve a final numerical standard (i.e., cleanup level) for any affected media. As a result, performance monitoring will consist primarily of construction quality assurance (CQA) monitoring to confirm that the interim action is constructed in conformance with the interim action design drawings and specifications. Additionally, the dredged material will be sampled and tested following moisture conditioning to document the concentrations of dioxins/furans of the in-place material.

CQA monitoring will include physical testing and construction observations to confirm that the interim action is constructed consistent with the intent of the interim action plan. All phases of dredged material dewatering, moisture conditioning, Site preparation, transport and placement at the Site, and covering will be observed by representatives of the Port engineering team. Physical testing will include determination of the moisture content and moisture/density relationships of the moisture-conditioned material to verify that a workable soil is achieved for placement at the Site. The locations, alignments and grades for haul roads, stormwater berms and ditches, and LFG system components will be surveyed and documented in record drawings to confirm that interim action requirements are achieved.

Stormwater will be monitored at both the GP site and the Site. Stormwater at the GP site will be discharged to the former GP Aeration Stabilization Basin (ASB) lagoon and is being addressed as part of the Gate 3 dredging project, not as part of the interim action. As indicated in Section 3.3.4, the Port will comply with the requirements of an NPDES construction stormwater permit issued separately by Ecology. The NPDES construction stormwater permit will require a Stormwater Pollution Prevention Permit which will identify monitoring requirements for Site stormwater, which is anticipated to include monitoring stormwater discharged to Bellingham Bay for turbidity, and will identify turbidity bench mark values that require modification to stormwater controls (25 NTU) and notification of Ecology (250 NTU).

Although extensive chemical testing of the Gate 3 sediment was conducted for the DMMP suitability determination (see Section 2.3.2), a limited number of additional samples will be collected and tested for dioxins/furans following dredged material offloading and moisture conditioning to document concentrations for the placed material. Between three and five samples of the moisture-conditioned

material will be tested for dioxins/furans, depending of the volume of material placed at the Site. Five samples will be tested if the maximum 40,800 yd³ is placed at the Site and three samples will be tested if the lesser dredge volume of 24,900 yd³ is placed at the Site.

Monitoring wells MW-2, MW-3, MW-4, MW-7, MW-8, and MW-10 are located within the footprint of the interim action area and will be decommissioned during the interim action. For each existing groundwater monitoring well decommissioned pursuant to this interim action, a new monitoring well will be installed at a location approved by Ecology subsequent to completion of the interim action. Plans for future monitoring will be established following the completion of the Interim Action and may include analysis for dioxin/furans.

3.5.3 CONFIRMATION MONITORING

Confirmation monitoring will be conducted to confirm the long term effectiveness of the interim action. Confirmation monitoring will consist of regular inspection of the interim action to confirm that the IPAs remain covered and that stormwater controls are adequately maintained and remain effective. Additionally, periodic construction stormwater monitoring will be conducted until the Site is determined to be adequately stabilized following the completion of interim action construction activities.

3.6 INTEGRATION WITH FINAL CLEANUP ACTION AND FUTURE LAND USE

The interim action will be integrated into the final Site cleanup action that will be completed following finalization of the Site RI/FS and issuance of a Cleanup Action Plan by Ecology. It is anticipated that the design for the final cleanup action will establish the elevations and grades for final capping of the Site and integration of the final cleanup action with future Site use. The beneficial reuse material would be regraded, placed, and compacted to achieve the finish grades determined during final design, and the LFG control system installed during the interim action will be integrated into the LFG system designed for the remainder of the Site. It is anticipated that the final cleanup action will be implemented within 2 to 5 years, so the interim action capping and stormwater controls will have to be maintained during this period.

The interim action is consistent with anticipated future land use. Based on the Waterfront District Draft Sub-Area Plan (Port of Bellingham 2010), planned future land use for the interim action area is as a City park, as shown on Figure 8. Anticipated uses for the park include a segment of a major regional bike trail, a lawn for informal gathering and recreation, and habitat restoration along the shoreline. The interim action will provide the material to create the topography needed for planned park uses as well as stormwater drainage. Creation of the park will require a large quantity of fill to establish the necessary

topographic relief. Beneficial reuse of the dredged material will significantly reduce, if not eliminate, the need to import fill soil from commercial upland borrow sources to the Site, greatly reducing both the number of truck trips through the City and the use of a valuable natural resource. (Note: MTCA is specific about how to analyze benefits of a cleanup remedy for purposes of MTCA decision-making. Some of the benefits mentioned in this Plan promote sustainability in a holistic way, but are not part of the MTCA criteria.)

4.0 USE OF THIS REPORT

It is anticipated this report will be subject to public comment and Ecology approval as an exhibit to an amendment to Agreed Order No. 1778. As an exhibit to the Agreed Order, this report will become an integral and enforceable part of the Agreed Order, administered by the Washington State Department of Ecology. This Interim Action Plan has been prepared for the use of the Port of Bellingham and the Washington State Department of Ecology for specific application to the Cornwall Avenue Landfill project. None of the information, conclusions, and recommendations included in this document can be used for any other project without the express written consent of Landau Associates. Further, the reuse of information, conclusions, and recommendations provided herein for extensions of the project or for any other project, without review and authorization by Landau Associates, shall be at the user's sole risk. Landau Associates warrants that within the limitations of scope, schedule, and budget, our services have been provided in a manner consistent with that level of care and skill ordinarily exercised by members of the profession currently practicing in the same locality under similar conditions as this project. We make no other warranty, either express or implied.

This document has been prepared under the supervision and direction of the following key staff.

LANDAU ASSOCIATES, INC.

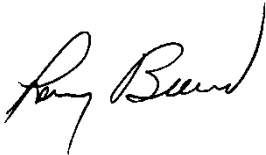

Lawrence D. Beard, P.E.
Principal

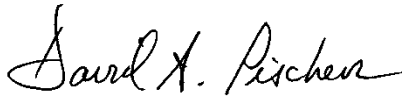

David A. Fischer, P.E.
Senior Associate

LDB/DAP/kes

5.0 REFERENCES

- Anchor Environmental and Hart Crowser. 1999. *Remedial Investigation/Feasibility Study, Whatcom Waterway Site*. August 4.
- Blumen. 2010. *Final Environmental Impact Statement, The Waterfront District Redevelopment Project, Port of Bellingham, Bellingham, Washington*. January.
- Dames & Moore. 1960. *Report of Foundation Investigation, Proposed Site Development, Bloedel-Donovan Mill Site, Bellingham, Washington*. December 19.
- Ecology. 2004. *Policy 130A: Coordination of SEPA and MTCA*. Washington State Department of Ecology. July 28.
- Ecology. 1992a. *Sediment and Seep Sampling at Cornwall Avenue Landfill, Bellingham, Washington*. Washington State Department of Ecology. May 6.
- Ecology. 1992b. *Site Hazard Assessment, Cornwall Avenue Landfill, Foot of Cornwall Avenue, Bellingham, Washington*. Washington State Department of Ecology, Northwest Regional Office. Bellevue, Washington. June.
- Ecology and CTED. 2006. *Impacts of Climate Change on Washington's Economy: A Preliminary Assessment of Risks and Opportunities*. Washington State Department of Ecology and Washington State Department of Community, Trade and Economic Development. November.
- Hart Crowser. 2009. *Sediment Site Characterization Evaluation of Bellingham Bay Creosote Piling and Structure Removal, Cornwall Avenue Landfill Mapping, Boulevard Park Overwater Walkway Feasibility, and Dioxin Background Sampling and Analysis, Bellingham, Washington*. Prepared for Washington State Department of Ecology. June 26.
- Landau Associates. 2010. *Sediment Characterization Report, Gate 3 Floats F & G Replacement Project, Squalicum Outer Harbor, Port of Bellingham*. Prepared for Port of Bellingham. November 3.
- Landau Associates. 1997. *Report, Expanded Site Investigation, Cornwall Landfill Investigation, Bellingham, Washington*.
- Port of Bellingham. 2010. *The Waterfront District Draft Sub-Area Plan, A Port of Bellingham/City of Bellingham Partnership Project*.
- Purnell, W.D. & Associates. 1985. *Engineering Geology and Geotechnical Investigation Tissue Warehouse Additions, Bellingham, Washington*. March 20.
- Tetra Tech, Inc. and Historical Research Associates, Inc. 1995. *Initial Characterization of Contaminants and Uses at the Cornwall Landfill and in Bellingham Bay*. Prepared for Attorney General of Washington. June 30.
- USACE. 2011. Tide Datum Regions, San Juan Island Region, Station 130 Bellingham, email link: <http://www.nws.usace.army.mil/PublicMenu/Documents/Reg/applications/tides/sj/sj130.cfm>

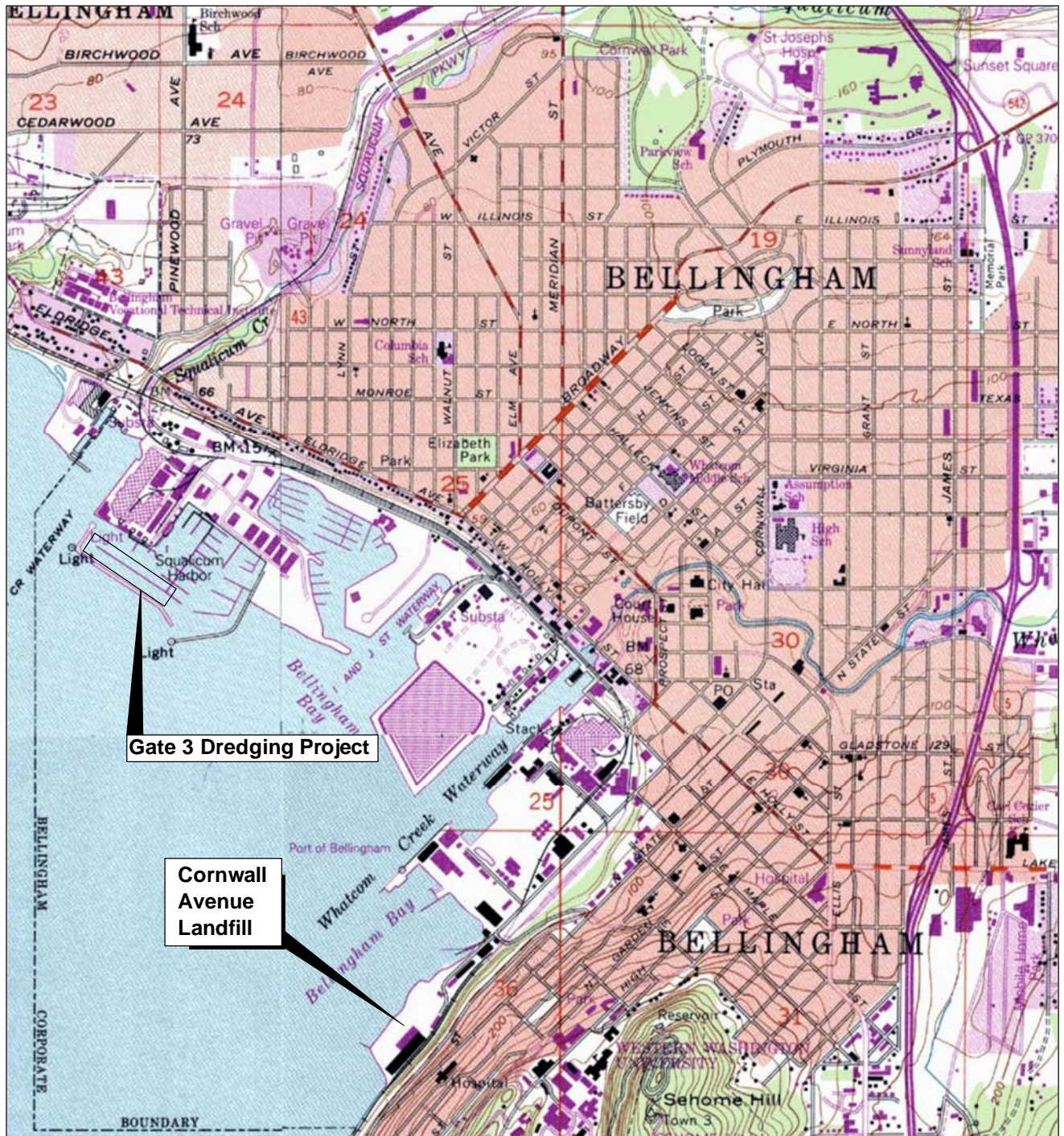

Map from DeLorme Street Atlas USA 2002

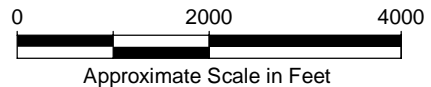

<p>Cornwall Avenue Landfill Interim Action Plan Bellingham, Washington</p>	<p>Vicinity Map</p>	<p>Figure 1</p>
--	----------------------------	----------------------------

Port of Bellingham \ Cornwall Avenue Landfill \ Interim Action Plan \ V:\001\020\400\450\LFG Vents\Figure 2.dwg (A) "Figure 2" 3/23/2011

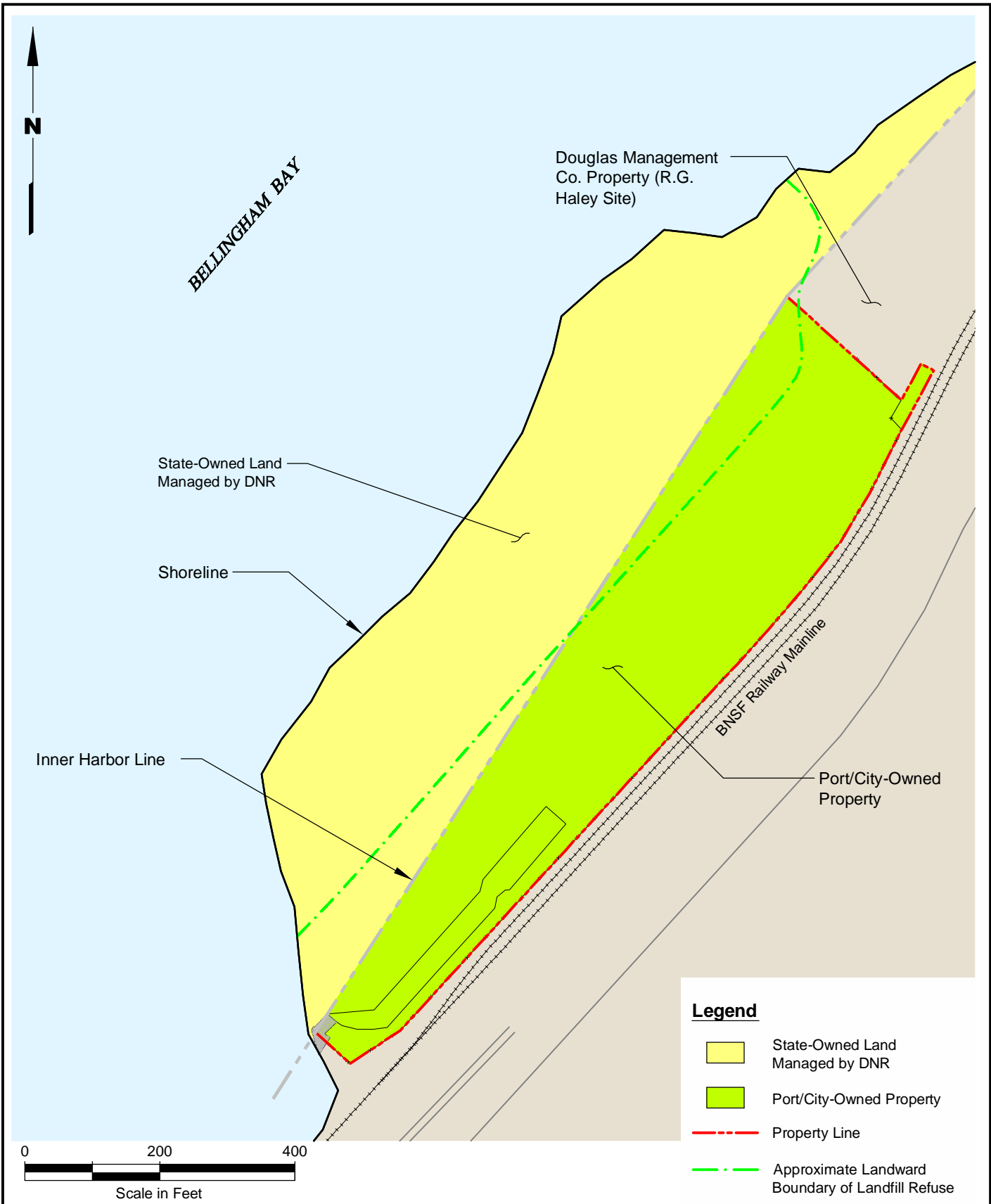

Basemap source: Port of Bellingham 1996, Anchor Environmental 2008

Cornwall Avenue Landfill
Interim Action Plan
Bellingham, Washington

Current Conditions Site Plan

Figure
2



Port of Bellingham \ Cornwall Avenue Landfill \ Interim Action Plan \ V:\001\020\400\450\LFG Vents R2\Figures 3, 6 & 7.dwg (A) Figure 3 5/3/2011

BELLINGHAM BAY

- Legend**
- - - LFG Collection Line
 - - - Approximate Landward Boundary of Landfill Refuse
 - ▨ Proposed Access Road
 - ▩ Proposed Berm

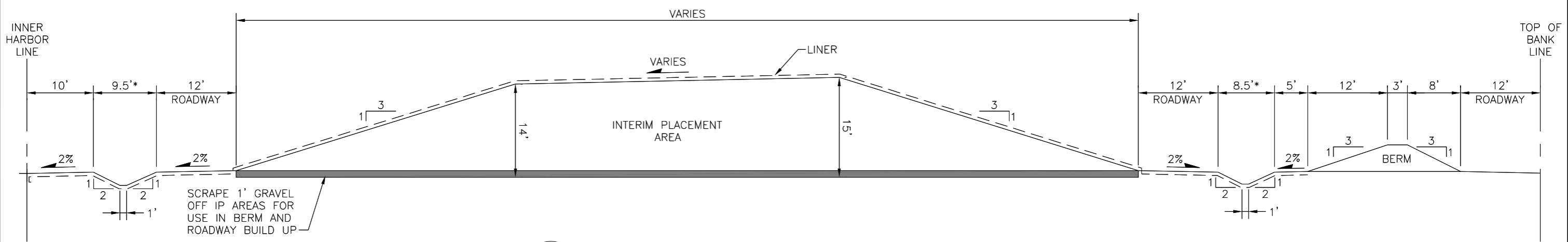
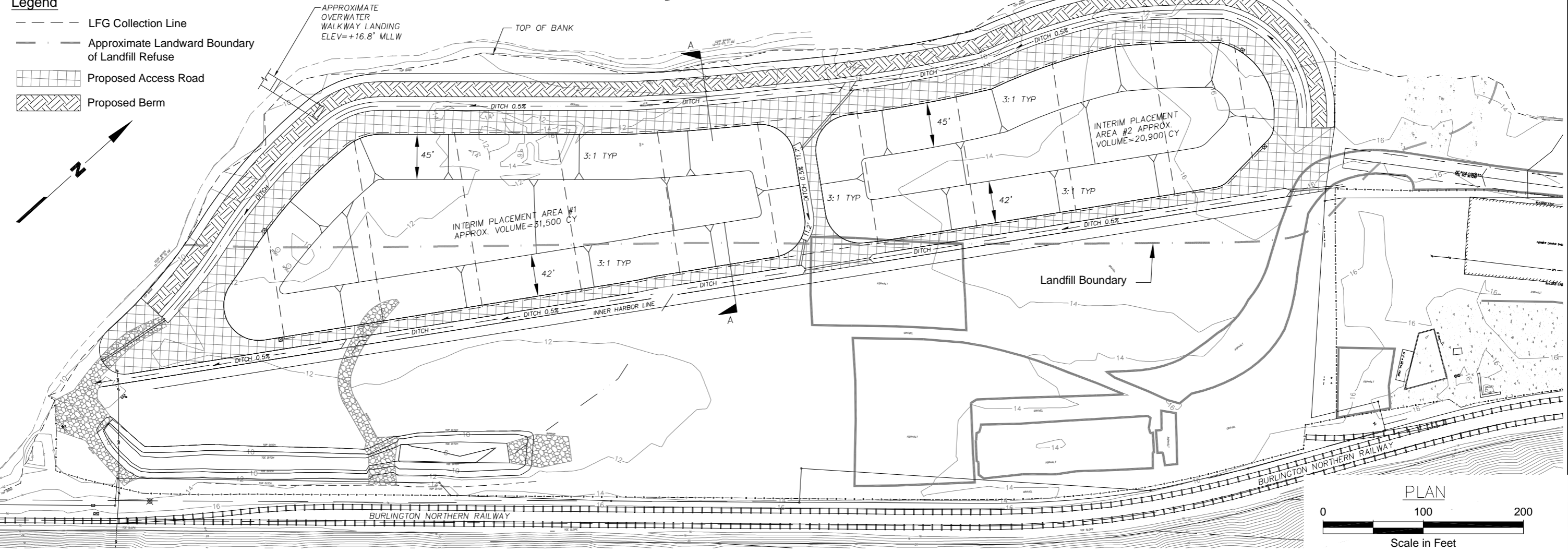

A CORNWALL UPLAND BENEFICIAL REUSE SITE SECTION
SCALE: 1"=60'

Source: Reid Middleton 2011



<p>Cornwall Avenue Landfill Interim Action Plan Bellingham, Washington</p>	<p>Interim Action Site Plan and Section</p>	<p>Figure 3</p>
--	--	----------------------------

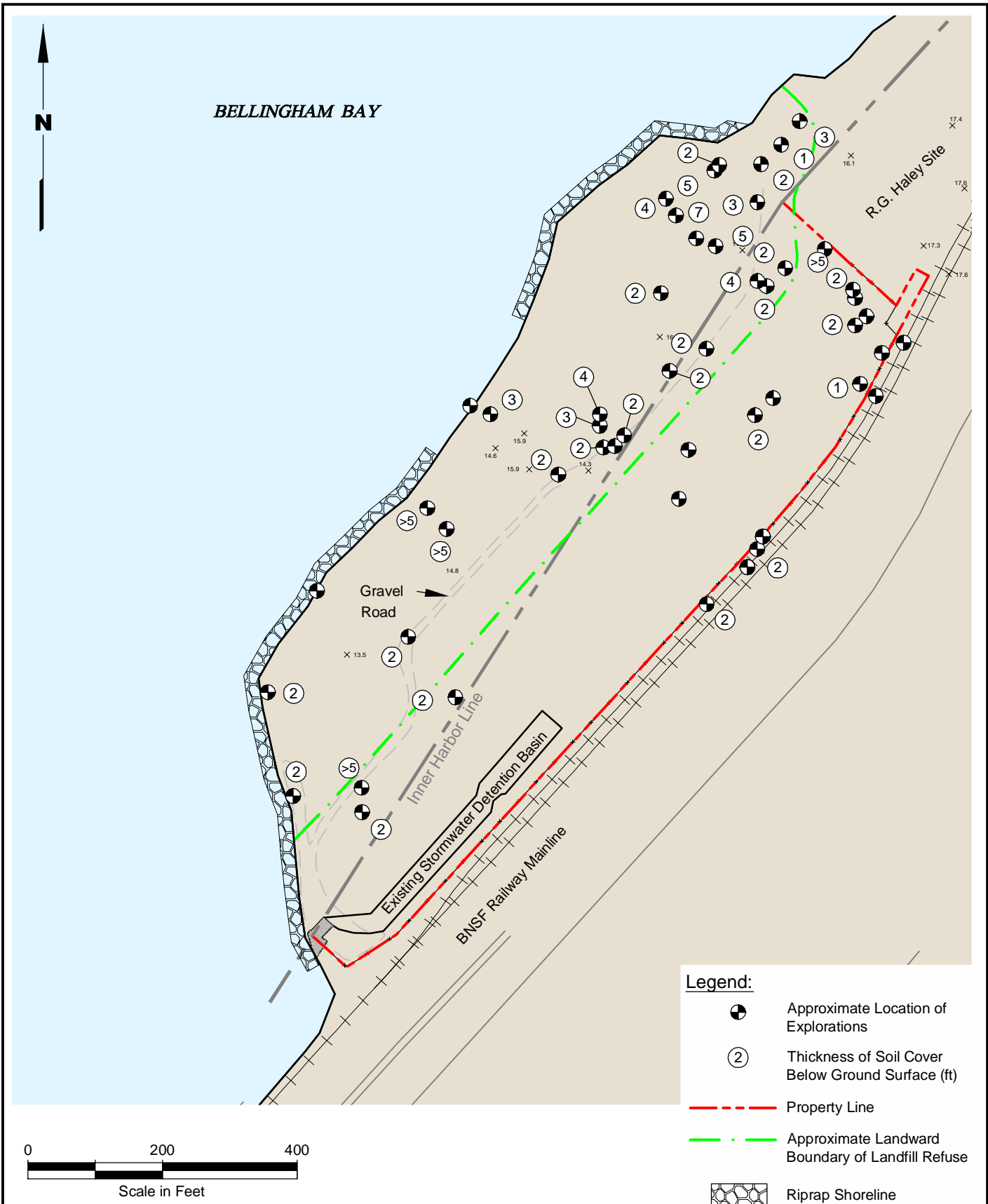

Basemap source: Port of Bellingham 1996, Anchor Environmental 2008

<p>Cornwall Avenue Landfill Interim Action Plan Bellingham, Washington</p>	<p>Soil Cover Thickness</p>	<p>Figure 4</p>
--	------------------------------------	----------------------------

Port of Bellingham \ Cornwall Avenue Landfill \ Interim Action Plan \ V:\001020\400\450\LFG_Ventis\Figure 5.dwg (A) *Figure 5* 3/7/2011

Legend



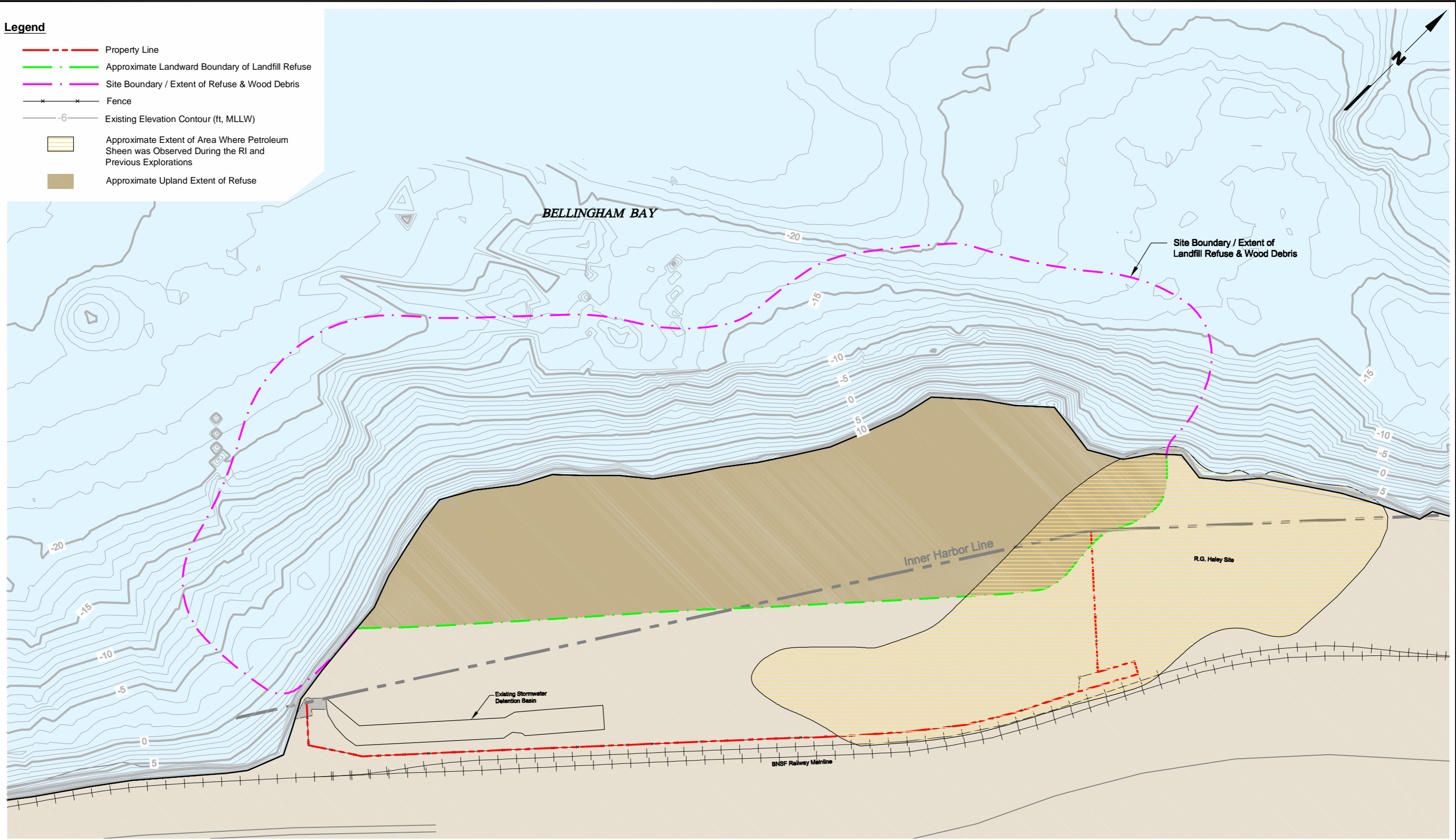

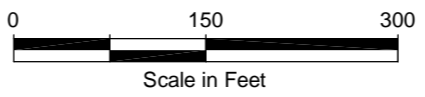

- - - Property Line
- . - Approximate Landward Boundary of Landfill Refuse
- . - Site Boundary / Extent of Refuse & Wood Debris
- Fence
- Existing Elevation Contour (ft, MLLW)
- Approximate Extent of Area Where Petroleum Sheen was Observed During the RI and Previous Explorations
- Approximate Upland Extent of Refuse



Basemap source: Port of Bellingham 1996, Anchor Environmental 2008



Legend

-  LFG Collection Line
-  Approximate Landward Boundary of Landfill Refuse
-  Approximate Liner Area
-  Approximate Extent of Area Where Petroleum Sheen was Observed During the RI and Previous Explorations
-  Proposed Access Road
-  Proposed Berm

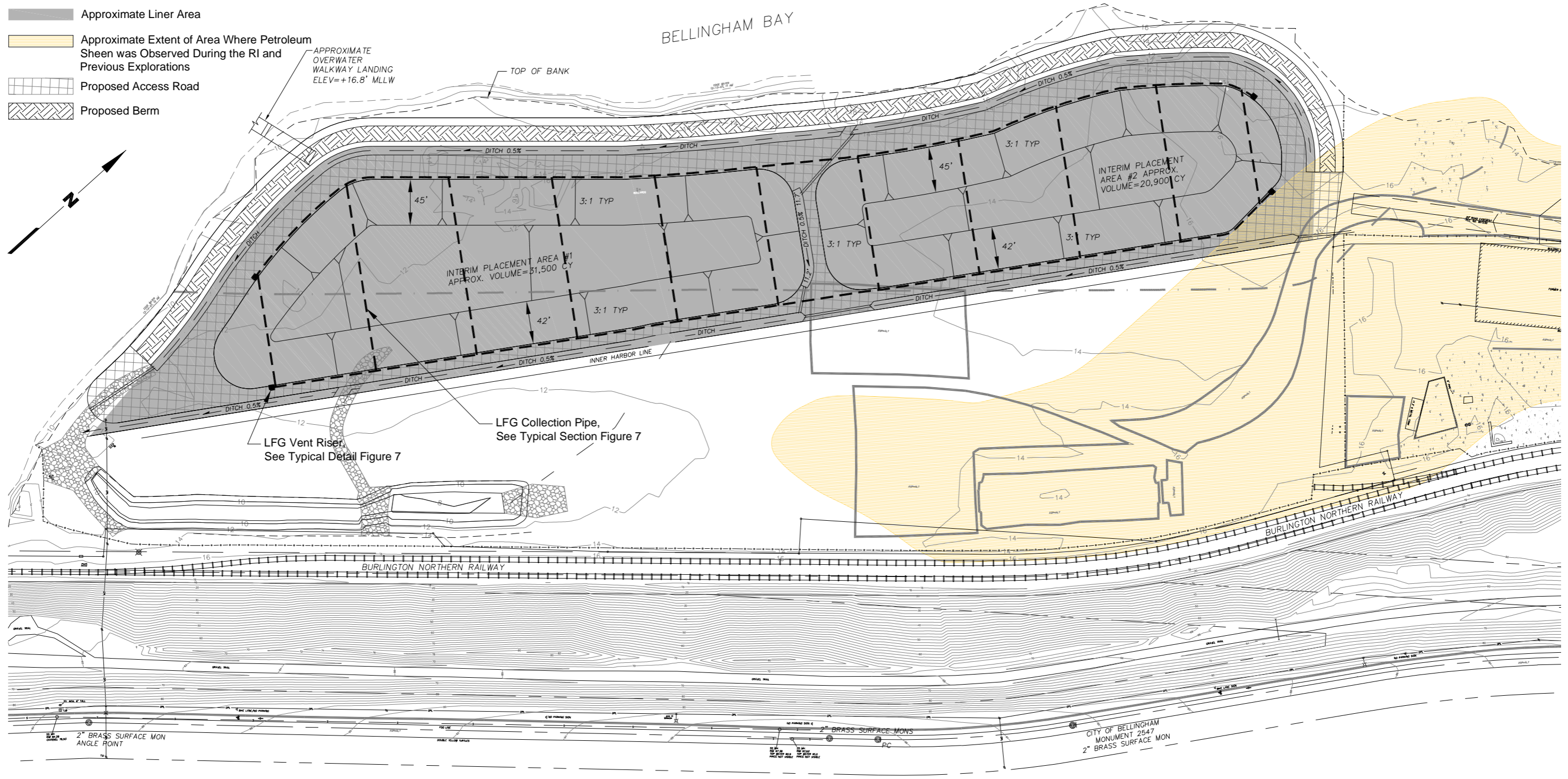

Port of Bellingham \ Cornwall Avenue Landfill \ Interim Action Plan \ V:\001\020\400\450\LFG_Vents_R2\Figures 3, 6 & 7.dwg (A) Figure 6' 5/3/2011

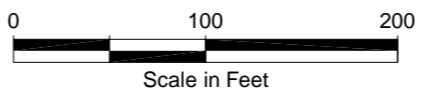

Base map source: Reid Middleton 2011

Cornwall Avenue Landfill Interim Action Plan Bellingham, Washington	LFG Control System Schematic	Figure 6
---	---	--------------------

Port of Bellingham \ Cornwall Avenue Landfill \ Interim Action Plan \ V:\001\020\400\450\LFG Vents R2\Figures 3, 6 & 7.dwg (A) Figure 7 5/3/2011

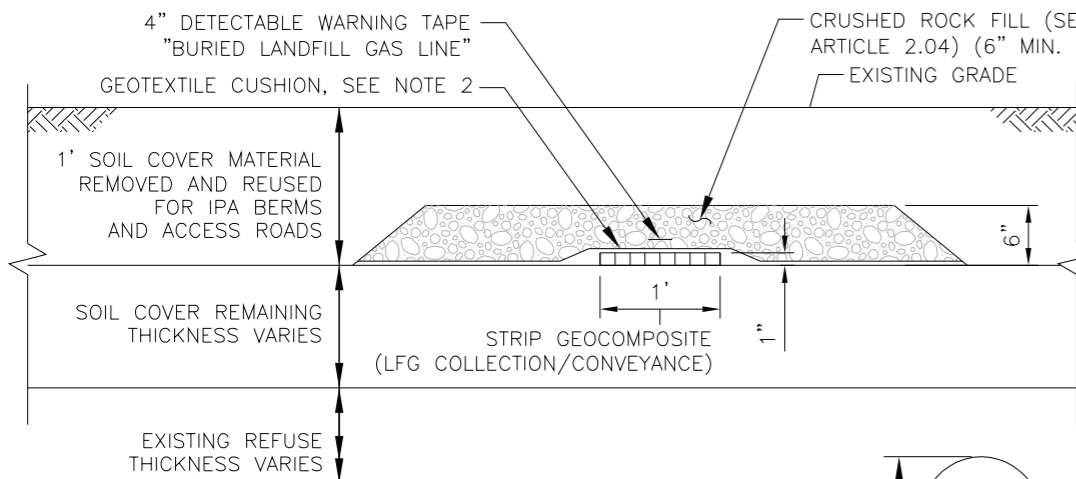

1 LFG COLLECTION/CONVEYANCE LINE DETAIL
SCALE: NTS

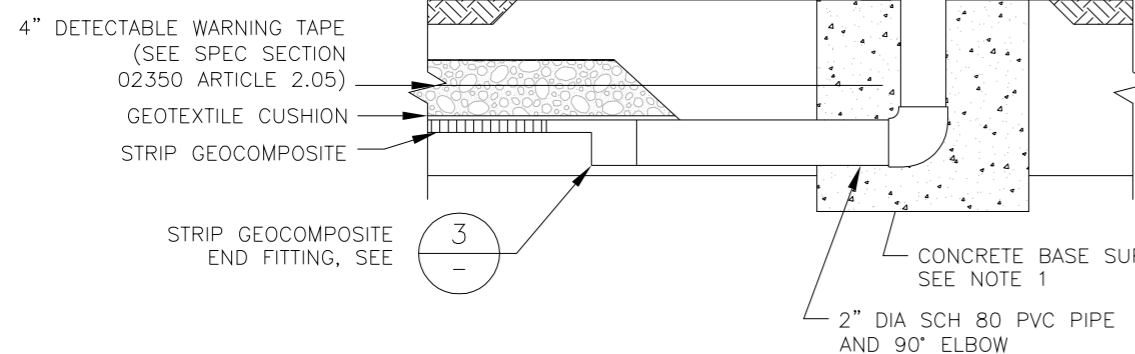

2 LFG VENT RISER DETAIL
SCALE: NTS

NOTES

1. WHERE LFG COLLECTION/CONVEYANCE LINE CROSSES UNDER DITCH, THE STRIP COMPOSITE MUST BE 1' BELOW THE BOTTOM LINER OF THE DITCH.
2. GEOTEXTILE CUSHION SHALL BE MIN. 12 OZ/SQ. YD. (SEE SPEC SECTION 02350 ARTICLE 2.03)

NOTE

1. CONCRETE BASE SUPPORT SHALL EXTEND 3" BELOW THE BOTTOM OF PIPE, 12" ABOVE THE TOP OF LATERAL PIPING, AND EXTEND 12" Laterally IN ALL DIRECTIONS AROUND THE RISER PIPE.
2. VENT RISERS SHALL BE LOCATED APPROXIMATELY 2' OUTSIDE OF THE INTERIM PLACEMENT AREA BOUNDARY.
3. INSTALL THREE CONCRETE-FILLED STEEL BOLLARDS (3' ABOVE GROUND PAINTED YELLOW) AROUND EACH VENT RISER FOR TRAFFIC PROTECTION AS PER SPEC SECTION 02350)

NOTES

1. STRIP COMPOSITE SHALL BE 12" WIDE STRIP DRAIN BY (AS PER SPEC SECTION 02350 ARTICLE 2.02) DIMPLES SHALL FACE DOWN SEAMS AND TEE'S SHALL BE CONSTRUCTED IN ACCORDANCE WITH MFG. REC. PRACTICE AND TAPED WITH PVC DUCT TAPE.
2. LAYOUT AND CONTROL POINTS ARE FOR REFERENCE. ACTUAL LOCATIONS OF SYSTEM COMPONENTS MAY VARY BASED ON SITE CONDITIONS, AS APPROVED BY ENGINEER.
3. WHERE LFG COLLECTION / CONVEYANCE LINE INTERSECTS DITCH, THE STRIP GEOTEXTILE MUST BE 1' BELOW THE BOTTOM OF LINER OF THE DITCH.
4. CONTRACTOR TO PROVIDE A SURVEYORS REPORT BY A LICENSED PROFESSIONAL SURVEYOR GIVING THE ACTUAL LOCATIONS OF EACH CONTROL POINT AND PROVED HORIZONTAL AND VERTICAL DATA TO THE ENGINEER.

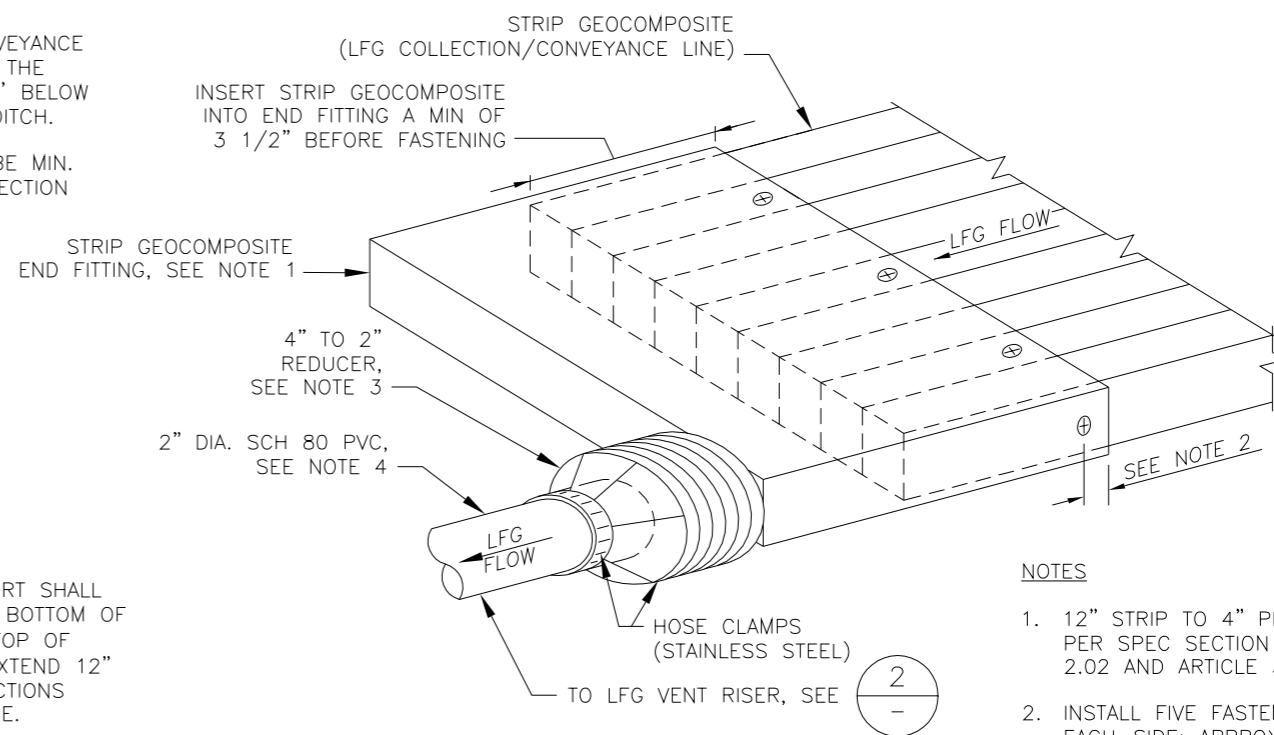

3 STRIP COMPOSITE END FITTING DETAIL
SCALE: NTS

NOTES

1. 12" STRIP TO 4" PIPE FITTING AS PER SPEC SECTION 02350 ARTICLE 2.02 AND ARTICLE 3.06.
2. INSTALL FIVE FASTENERS; 3-TOP; 1 EACH-SIDE; APPROXIMATELY 1 1/2" FROM END.
3. FERNCO RUBBER BOOT 4" TO 2" ADAPTER OR EQUAL AS APPROVED BY ENGINEER
4. INSERT 2" DIA. SCH 80 PVC A MIN. OF 5" INTO FERNCO BOOT.

Base map source: Reid Middleton 2011

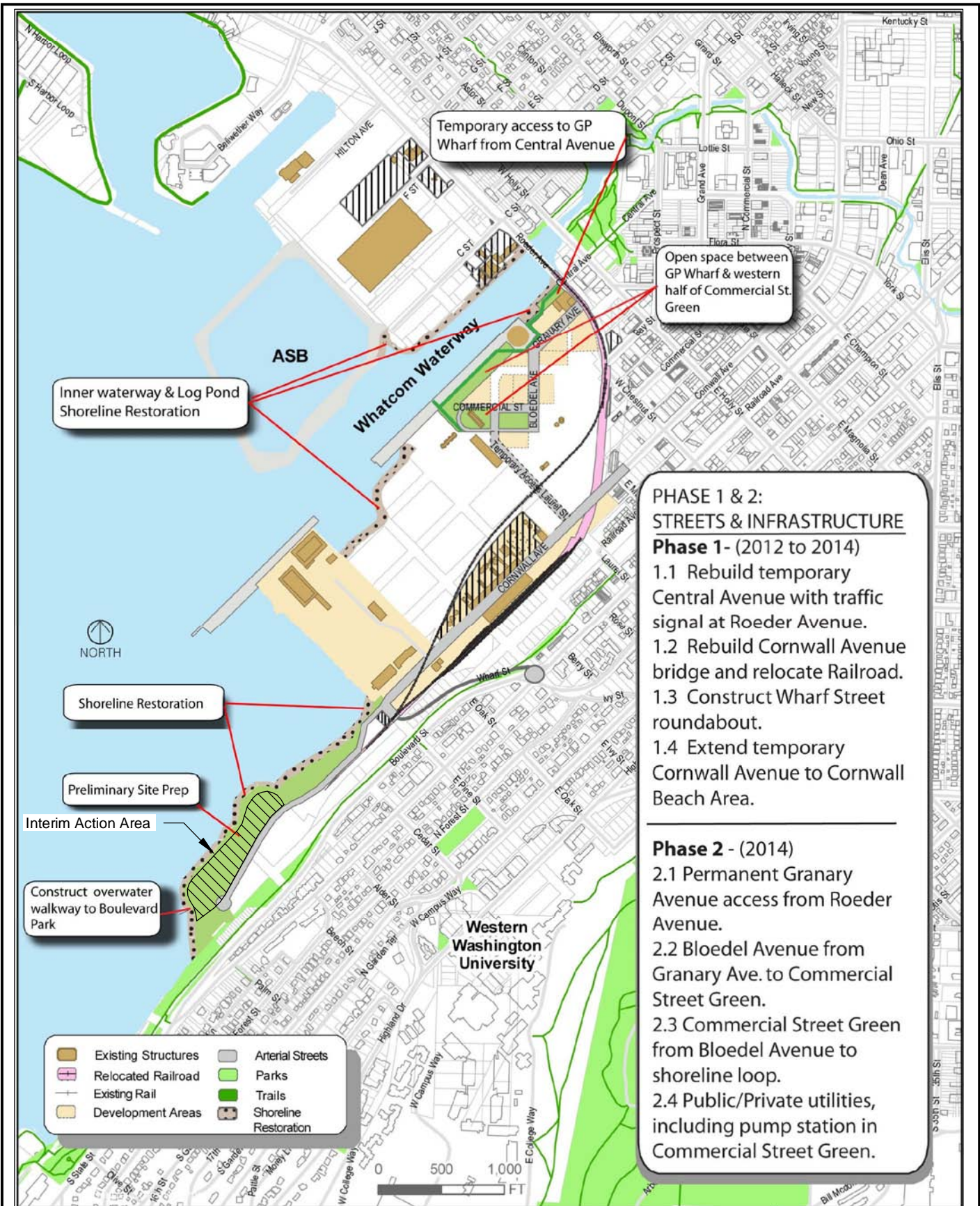

Source: Appendix A 2010 Waterfront District Draft SubArea Plan

Cornwall Avenue Landfill
Interim Action Plan
Bellingham, Washington

**Phases 1 & 2 - Waterfront
District SubArea Plan**

Figure
8

TABLE 1
2007 A-LAYER SEDIMENT SAMPLE ANALYTICAL RESULTS COMPARED TO MTCA CRITERIA
CORNWALL AVENUE LANDFILL INTERIM ACTION
BELLINGHAM, WASHINGTON

			DMMU POB 1		DMMU POB 2		DMMU POB 3	
	MTCA Method B Soil-direct Contact Screening Level	MTCA Method C Soil-direct Contact Screening Level	Gate3-CMP1 KQ93A/KR14A 3/8/2007	Gate3-Core1 KQ93B 3/8/2007	Gate3-CMP2 KQ93C/KR14B 3/8/2007	Gate3-Core5 KQ93D 3/8/2007	Gate3-CMP3 KQ93F/KR14C 3/9/2007	Gate3-Core9 KQ93E 3/9/2007
TOTAL METALS								
EPA Methods 6010B/7470A/7740 (mg/kg)								
Antimony	32	1,400	9 UJ		9 U		9 U	
Arsenic	20 (a)	20 (b)	9 U		9 U		9 U	
Cadmium	80	3500	0.4		0.4		0.4	
Chromium	120,000 (c)	5250000 (c)	73.9		75.1		74.5	
Copper	3,000	130,000	57.0		53.7		62.4	
Lead	250 (a)	1000 (b)	11		9		10	
Mercury	24	1,100	0.20		0.11		0.15	
Nickel	1600	70,000	116		123		118	
Selenium	400	18,000	0.6		0.3 U		0.5	
Silver	400	18,000	0.5 U		0.5 U		0.5 U	
Zinc	24,000	1,100,000	105		104		116	
PORE WATER TBT								
Krone (µg/L)								
Tributyl Tin Ion			0.019 U		0.019 U		0.019 U	
Dibutyl Tin Ion			0.029 U		0.029 U		0.029 U	
Butyl Tin Ion			0.020 U		0.020 U		0.020 U	
PAHs Method 8270 (µg/kg)								
Naphthalene			61 U		62 U		62 U	
Acenaphthylene			61 U		62 U		62 U	
Acenaphthene			61 U		62 U		62 U	
Fluorene			61 U		62 U		62 U	
Phenanthrene	--	--	82		62 U		86	
Anthracene			61 U		62 U		62 U	
2-Methylnaphthalene			61 U		62 U		62 U	
Fluoranthene	3,200,000	140,000,000	510		110		270	
Pyrene	2,400,000	110,000,000	630		87		200	
Benzo(g,h,i)perylene			61 U		62 U		62 U	
Benzo(a)anthracene			160		62 U		62 U	
Chrysene			200		62 U		120	
Benzo(b)fluoranthene			140		62 U		63	
Benzo(k)fluoranthene			110		62 U		100	
Benzo(a)pyrene	137	18,000	76		62 U		62 U	
Indeno(1,2,3-cd)pyrene			61 U		62 U		62 U	
Dibenzo(a,h)anthracene			9.8		6.2 U		6.8	
cPAH TEQ	137	18,000	120		ND		18	

TABLE 1
2007 A-LAYER SEDIMENT SAMPLE ANALYTICAL RESULTS COMPARED TO MTCA CRITERIA
CORNWALL AVENUE LANDFILL INTERIM ACTION
BELLINGHAM, WASHINGTON

			DMMU POB 1		DMMU POB 2		DMMU POB 3	
	MTCA Method B Soil-direct Contact Screening Level	MTCA Method C Soil-direct Contact Screening Level	Gate3-CMP1 KQ93A/KR14A 3/8/2007	Gate3-Core1 KQ93B 3/8/2007	Gate3-CMP2 KQ93C/KR14B 3/8/2007	Gate3-Core5 KQ93D 3/8/2007	Gate3-CMP3 KQ93F/KR14C 3/9/2007	Gate3-Core9 KQ93E 3/9/2007
VOLATILES								
EPA Method 8260B (µg/kg)								
1,3-Dichlorobenzene				1.8 U		1.8 U		1.8 U
1,4-Dichlorobenzene				1.8 U		1.8 U		1.8 U
1,2-Dichlorobenzene				1.8 U		1.8 U		1.8 U
1,2,4-Trichlorobenzene				9.0 U		8.9 U		8.8 U
Hexachlorobenzene			6.1 U		6.2 U		6.2 U	
Trichloroethene				1.8 U		1.8 U		1.8 U
Tetrachloroethene				1.8 U		1.8 U		1.8 U
Ethylbenzene				1.8 U		1.8 U		1.8 U
m,p-Xylene				1.8 U		1.8 U		1.8 U
o-Xylene				1.8 U		1.8 U		1.8 U
Total Xylene								
SEMIVOLATILES								
EPA Method 8270B (µg/kg)								
Dimethylphthalate			61 U		62 U		62 U	
Diethylphthalate			61 U		62 U		62 U	
Di-n-Butylphthalate	8,000,000	350,000,000	61 U		62 U		62 U	
Butylbenzylphthalate			6.1 U		6.2 U		6.2 U	
bis(2-Ethylhexyl)phthalate	71,000	9,400,000	61 U		62 U		78	
Di-n-Octyl phthalate			61 U		62 U		62 U	
Phenol			61 U		62 U		62 U	
2-Methylphenol			6.1 U		6.2 U		6.2 U	
4-Methylphenol			61 U		62 U		62 U	
2,4-Dimethylphenol			6.1 U		6.2 U		6.2 U	
Pentachlorophenol			31 U		31 U		31 U	
Benzyl Alcohol			31 U		31 U		31 U	
Benzoic Acid			610 U		620 U		620 U	
Dibenzofuran			61 U		62 U		62 U	
Hexachloroethane			61 U		62 U		62 U	
Hexachlorobutadiene			6.1 U		6.2 U		6.2 U	
N-Nitrosodiphenylamine			6.1 U		6.2 U		6.2 U	

TABLE 1
2007 A-LAYER SEDIMENT SAMPLE ANALYTICAL RESULTS COMPARED TO MTCA CRITERIA
CORNWALL AVENUE LANDFILL INTERIM ACTION
BELLINGHAM, WASHINGTON

			DMMU POB 1		DMMU POB 2		DMMU POB 3	
	MTCA Method B Soil-direct Contact Screening Level	MTCA Method C Soil-direct Contact Screening Level	Gate3-CMP1 KQ93A/KR14A 3/8/2007	Gate3-Core1 KQ93B 3/8/2007	Gate3-CMP2 KQ93C/KR14B 3/8/2007	Gate3-Core5 KQ93D 3/8/2007	Gate3-CMP3 KQ93F/KR14C 3/9/2007	Gate3-Core9 KQ93E 3/9/2007
PESTICIDES								
PSDDA Method 8081A (µg/kg)								
4,4'-DDE			2.0 U		2.0 U		2.0 U	
4,4'-DDD			2.0 U		2.0 U		2.0 U	
4,4'-DDT			2.0 U		2.0 U		2.0 U	
Aldrin			0.99 U		1.0 U		0.98 U	
gamma Chlordane			1.7 U		1.0 U		0.98 U	
alpha Chlordane			0.99 U		1.0 U		0.98 U	
Total Chlordane			0.99 U		1.0 U		0.98 U	
Dieldrin			2.0 U		2.0 U		2.0 U	
Heptachlor			0.99 U		1.0 U		0.98 U	
gamma-BHC (Lindane)			0.99 U		1.0 U		0.98 U	
POLYCHLORINATED BIPHENYLS (PCBs)								
PSDDA Method 8082 (µg/kg)								
Aroclor 1016			20 U		20 U		20 U	
Aroclor 1242			20 U		20 U		20 U	
Aroclor 1248			20 U		20 U		20 U	
Aroclor 1254			20 U		20 U		20 U	
Aroclor 1260			20 U		20 U		20 U	
Aroclor 1221			20 U		20 U		20 U	
Aroclor 1232			20 U		20 U		20 U	
Total PCBs			ND		ND		ND	
CONVENTIONAL CHEMISTRY PARAMETERS								
(mg/kg, unless noted)								
Total Solids (% , Method 160.3)			56.00		56.80		54.10	
Total Volatile Solids (% , Method 160.4)			5.55		5.43		5.74	
Preserved Total Solids (% , Method 160.3)				53.10		53.60		52.70
Total Organic Carbon (% , PLUMB81TC)			1.65		1.27		1.12	
Ammonia (NH3) as Nitrogen (N) (Method 350.1)			24.0 J		24.2 J		16.0	
Sulfide (Method 376.2)				1,980		1,850		1,350

TABLE 1
2007 A-LAYER SEDIMENT SAMPLE ANALYTICAL RESULTS COMPARED TO MTCA CRITERIA
CORNWALL AVENUE LANDFILL INTERIM ACTION
BELLINGHAM, WASHINGTON

			DMMU POB 1		DMMU POB 2		DMMU POB 3	
	MTCA Method B Soil-direct Contact Screening Level	MTCA Method C Soil-direct Contact Screening Level	Gate3-CMP1 KQ93A/KR14A 3/8/2007	Gate3-Core1 KQ93B 3/8/2007	Gate3-CMP2 KQ93C/KR14B 3/8/2007	Gate3-Core5 KQ93D 3/8/2007	Gate3-CMP3 KQ93F/KR14C 3/9/2007	Gate3-Core9 KQ93E 3/9/2007
CHLORINATED DIOXINS (ng/kg)								
Method 8290								
2,3,7,8-TCDD	11	1460	0.270		0.178		0.385	
1,2,3,7,8-PeCDD			1.60		0.882		3.85	
1,2,3,4,7,8-HxCDD			3.90		2.65		10.6	
1,2,3,6,7,8-HxCDD			14.7		8.31		42.1	
1,2,3,7,8,9-HxCDD			8.05		4.36		23.3	
1,2,3,4,6,7,8-HpCDD			349		205		954	
OCDD			2,390		1,910		6,670	
Total TCDD			51.2		50.4		58.0	
Total PeCDD			41.4		36.8		56.2	
Total HxCDD			212		128		370	
Total HpCDD			1,040		599		2,320	
CHLORINATED FURANS (ng/kg)								
Method 8290								
2,3,7,8-TCDF			2.04		1.52		2.79	
1,2,3,7,8-PeCDF			1.05		0.581		2.92	
2,3,4,7,8-PeCDF			1.13		0.493		1.85	
1,2,3,4,7,8-HxCDF			3.45		1.99		7.47	
1,2,3,6,7,8-HxCDF			1.50		0.951		3.91	
2,3,4,6,7,8-HxCDF			2.39		1.38		5.54	
1,2,3,7,8,9-HxCDF			1.30		0.757		3.13	
1,2,3,4,6,7,8-HpCDF			34.8		17.1		87.3	
1,2,3,4,7,8,9-HpCDF			2.08		1.27		3.68	
OCDF			98.0		49.6		181	
Total TCDF			14.7 J		9.49 J		18.4 J	
Total PeCDF			30.5 J		15.2 J		80.2 J	
Total HxCDF			87.3 J		47.0		248 J	
Total HpCDF			131		67.4		291	
TEQ (ND=1/2 DL) (d)	11	1460	10.6		6.2		27.3	
TEQ (ND=0) (e)	11	1460	10.6		6.2		27.3	

TABLE 1
2007 A-LAYER SEDIMENT SAMPLE ANALYTICAL RESULTS COMPARED TO MTCA CRITERIA
CORNWALL AVENUE LANDFILL INTERIM ACTION
BELLINGHAM, WASHINGTON

µg/kg = micrograms per kilogram (ppb).

mg/kg = milligrams per kilogram (ppm).

µg/L = micrograms per liter (ppb).

ng/kg = nanogram per kilogram (pptr)

TEQ = Toxicity equivalent.

U = Indicates the compound was not detected at the given reporting limit.

UJ = Indicates the compound was not detected; the given reporting limit is an estimate.

J = Indicates the compound was detected; the given concentration is an estimate.

J* = Analyte concentration is below calibration range.

ND = Not detected.

Bold cells indicate a detected compound.

Boxed cells indicate an exceedance of MTCA Method B screening level.

Constituents in red included in cPAH TEQ calculation

Shaded cells indicate an exceedance of MTCA Method C screening level.

-- = Indicates no criteria established for this compound.

(a) Value shown is the MTCA Method A cleanup level for unrestricted land use.

(b) Value shown is the MTCA Method A cleanup level for industrial land use.

(c) Value shown is for chromium III.

(d) TEQ calculated using 2005 World Health Organization (WHO) toxicity equivalency factors (TEFs) and one half the detection limit for non-detects.

(e) TEQ calculated using 2005 World Health Organization (WHO) toxicity equivalency factors (TEFs) and zero for non-detects.

Gate 3 Sediment Physical Properties

APPENDIX A

GATE 3 SEDIMENT PHYSICAL PROPERTIES

The physical properties of the Gate 3 sediment were evaluated to determine how the material will perform as a contouring material and as a component of a final capping system for the Site. Additionally, bench scale testing was conducted to estimate the amount of admixture that might be required to adequately moisture condition the sediment for placement and compaction. Physical testing included:

- Grain size distribution conducted as part of sediment characterization activities
- Atterberg limits to supplement the grain size distribution test results to confirm the soil type based on the Unified Soil Classification System (USCS)
- Natural moisture content to estimate the moisture content of the dredged material after initial dewatering but prior to drying or amendment
- Moisture-density relationships (Standard Proctor compaction test) to determine the moisture content range required for the sediment to be sufficiently moisture conditioned for placement, grading, and compaction
- Hydraulic conductivity of the sediment in a moisture-conditioned state to estimate the hydraulic properties of the sediment following placement and compaction
- Sediment stabilization testing to estimate the amount of an absorbent material (such as cement, fly ash, etc.) that would likely be required to adequately moisture condition the sediment for placement, grading, and compaction.

These tests provide the information necessary to establish the requirements for modifying the dredged sediment from a wet, soft material to a workable soil appropriate for use as a contouring fill material on the Site. Although the contractor will have the option of proposing alternative means for moisture conditioning the dredged sediment, the use of absorbent admixtures to stabilize and moisture condition soil is a demonstrated technology that has been successfully used on numerous projects to stabilize moisture-sensitive soil and sediment. The results of the stabilization testing also helps establish the baseline moisture conditioning requirements that the contractor will need to achieve prior to placement and compaction of the dredged material on the Site.

Representative sediment samples collected from the Gate 3 project area were blended to obtain a sufficient volume of relatively homogeneous material used for physical testing purposes. The results of the physical testing conducted on the Gate 3 sediment are provided in the following sections.

Grain Size Distribution

The grain size distribution of composite sediment samples Gate 3-CMP1 through Gate 3-CMP4, which were prepared from four sediment cores collected from each of the four DMMUs (POB 1 through POB 4), are presented on Figure A-1. The grain size testing was conducted at the Analytical Resources,

Inc. (ARI) laboratory using Method PSEP-PS, and the data indicates that the dredged material will primarily be a clayey silt with some sand.

Moisture Content

The natural moisture contents of seven sediment samples were determined in general accordance with American Society for Testing and Materials (ASTM) D 2216 test procedures. The samples tested exhibited natural moisture contents ranging from 70 to 86 percent. The unamended sediment used for bench scale laboratory testing was in a very soft, saturated condition and had an average moisture content of approximately 80 percent.

Based on professional judgment, the blended sediment had a reasonably high moisture content and likely approximated conditions that might be encountered after offloading and initial material handling/dewatering was conducted. Accordingly, sediment with a moisture content of about 80 percent was used as the basis for conducting the sediment moisture conditioning and stabilization testing program.

It should be understood that the moisture content of the sediment following dredging, barge dewatering, offloading, and initial handling/drainage to remove free water will depend on how the selected contractor handles the sediment and manages the water at the offloading/processing facility and could vary from the 80 percent water content assumed for this testing program.

Atterberg Limits

The Atterberg Limits (liquid limit, plastic limit, and plasticity index) of selected sediment samples were determined in general accordance with ASTM D 4318 test procedures. These index tests were conducted for the purpose of classification of fine-grained soils under the USCS, as well as to evaluate the plasticity of certain amended sediment samples.

Three samples of the unamended sediment were tested for Atterberg Limits, and the results are presented on Figure A-2. Based on these tests, the unamended sediment was classified as a MH material. The Atterberg Limits of two amended sediment samples are discussed below.

Moisture-Density Relationships

The wet density of the unamended sediment with a moisture content of about 80 percent was determined by used of standard weight/volume techniques. Based on nine measurements, the wet bulk density of the sediment used in the testing program was determined to range from 95 to 97 pounds per cubic foot (pcf) and averaged about 96 pcf, which equates to about 1.30 tons per cubic yard.

The optimum moisture/maximum dry density relationships of the unamended sediment and certain amended sediment materials were determined in general accordance with ASTM D 698 and ASTM D 558 (Standard Proctor compaction) test procedures. The test consists of compacting soil into a mold using a standardized compactive energy at several different levels of moisture content. The maximum dry density and optimum moisture content are determined from the results of the test, with the optimum moisture content being the moisture at which the maximum dry density is achieved.

A sample of the unamended sediment was air-dried in the laboratory to a workable soil condition prior to conducting the initial compaction test. Compaction test samples were moisture conditioned at increasing moisture contents using sea water obtained from the project site. The optimum moisture content and maximum dry density for the unamended sediment were determined to be about 26.5 percent and 93 pcf, respectively. The moisture-density relationship for the unamended sediment is presented on Figure A-3.

Based on these results, the moisture content of the Gate 3 sediment would need to be significantly reduced to achieve its optimum moisture content. Although optimum moisture is ideal for compaction of soil for structural applications, it is preferable to compact fine-grained soil at moisture contents that are several percent above optimum when used for a low permeability soil application because this results in a lower hydraulic conductivity and maintains a more flexible, elastic consistency than achieved when the soil is compacted at lower moisture contents.

The moisture-density relationships of two amended sediment samples are discussed below.

Hydraulic Conductivity

The vertical hydraulic conductivity of moisture-conditioned and compacted sediment was tested to evaluate its performance in limiting infiltration of stormwater. Hydraulic conductivity testing of compacted sediment samples was performed using a flexible wall permeameter in general accordance with ASTM D 5084 (Method C) test procedures. The test samples were trimmed from the 4-inch diameter compacted sediment samples prepared as part of the moisture-density tests discussed above. Following sample preparation and saturation in the triaxial test chamber, water flow through the sample under falling head, increasing tailwater conditions was measured and used to calculate the hydraulic conductivity of the material.

The unamended sediment sample was prepared from the material compacted about 7 percent above optimum moisture (see Figures A-3 and A-6). The unamended material had a permeability of approximately 4×10^{-8} centimeters per second (cm/sec).

The hydraulic conductivity results for two amended sediment samples are discussed below.

Sediment Stabilization Testing

A bench-scale sediment stabilization testing program was conducted to evaluate what types and approximate percentages of absorbent material would likely need to be blended with the very soft, wet dredged sediment to produce a beneficial reuse material with a friable, soil-like consistency and a moisture content (within approximately 2 to 7 percent of optimum) that allows for subsequent handling, placement, and compaction as fill material using conventional earthwork equipment.

The initial stabilization mix design testing consisted of mixing wet sediment with various percentages of cement kiln dust (CKD), Class C fly ash (FA-C), Class F fly ash (FA-F), 50/50 mix of Portland cement and Class C fly ash (50/50), lime, lime kiln dust (LKD), and Type I/II Portland cement (cement), with the addition of dry absorbent based on a percentage of the wet weight of the unamended sediment. The resulting materials were then evaluated based on visual and textural observations supplemented with moisture content determinations over a period of several days to a week. Based on the initial test results, bench scale admixture tests using lime, LKD, CKD, and FA-F were discontinued due to either unsatisfactory performance or indications of the need to add relatively high percentages of absorbent materials.

A second round of stabilization mix design testing consisted of mixing wet sediment with certain percentages of cement and FA-C, with the addition of dry absorbent based on a percentage of the wet weight of the dredged material. The resulting materials were then evaluated based on visual and textural observations supplemented with moisture content determinations over a period of several days. A general summary of the bench-scale admixture tests and performance observations are presented in Table A-1.

Based on these test results, the following two dredged material (DM) mix designs were carried forward for subsequent pre-design testing: DM + 7.5% cement, and DM + 20% FA-C, discussed below. For the purpose of sediment stabilization using pozzolan materials, “mellowing” refers to the time directly after blending when the DM and pozzolan is allowed to react and develop a workable, soil-like consistency, and “curing” refers to the time following compaction.

Cement-Amended Sediment

A batch of the DM + 7.5% cement was prepared, allowed to mellow for a period of about three days, and then tested for compaction, plasticity, and hydraulic conductivity characteristics.

The moisture-density relationship for the cement-amended sediment is presented on Figure A-4. The optimum moisture content and maximum dry density for the cement-amended sediment were determined to be about 54 percent and 65 pcf, respectively.

The Atterberg Limits determined for the cement-amended sediment are presented on Figure A-2. The test results confirmed textural observations that the plasticity of the dredged material was reduced by cement-amendment.

The hydraulic conductivity of the cement-amended sediment was determined on a sample prepared from the material compacted about 7 percent above optimum moisture content (see Figures A-4 and A-6). The cement-amended material had a permeability of approximately 4×10^{-7} cm/sec.

Fly Ash-Amended Sediment

A batch of the DM + 20% FA-C was prepared, allowed to mellow for a period of about three days, and then tested for compaction, plasticity, and hydraulic conductivity characteristics.

The moisture-density relationship for the fly ash-amended sediment is presented on Figure A-5. The optimum moisture content and maximum dry density for the fly ash-amended sediment were determined to be about 41 percent and 74 pcf, respectively.

The Atterberg Limits of the fly ash-amended sediment are presented on Figure A-2. The test results confirmed textural observations that the plasticity of the dredged material was reduced by Class C fly ash amendment.

The hydraulic conductivity of the fly ash-amended sediment was determined on a sample prepared from the material compacted about 10 percent above optimum moisture content (see Figures A-5 and A-6). The fly ash-amended material had a permeability of approximately 5×10^{-7} cm/sec.

Summary

The bench-scale test program discussed above shows that, as anticipated, the cement- or fly ash-amended sediment has a lower maximum dry density and higher optimum moisture content than the unamended sediment (see Figure A-6). The hydraulic conductivity of the amended sediment remains relatively low and suitable for its intended use.

The results of the sediment stabilization test program demonstrates that the soft, wet sediment to be dredged as part of the Port's Gate 3 project can be processed and moisture conditioned by mixing with common pozzolan materials to produce a beneficial reuse material with a friable, soil-like consistency that will allow for subsequent placement and compaction as relatively low permeability fill material at the Site.

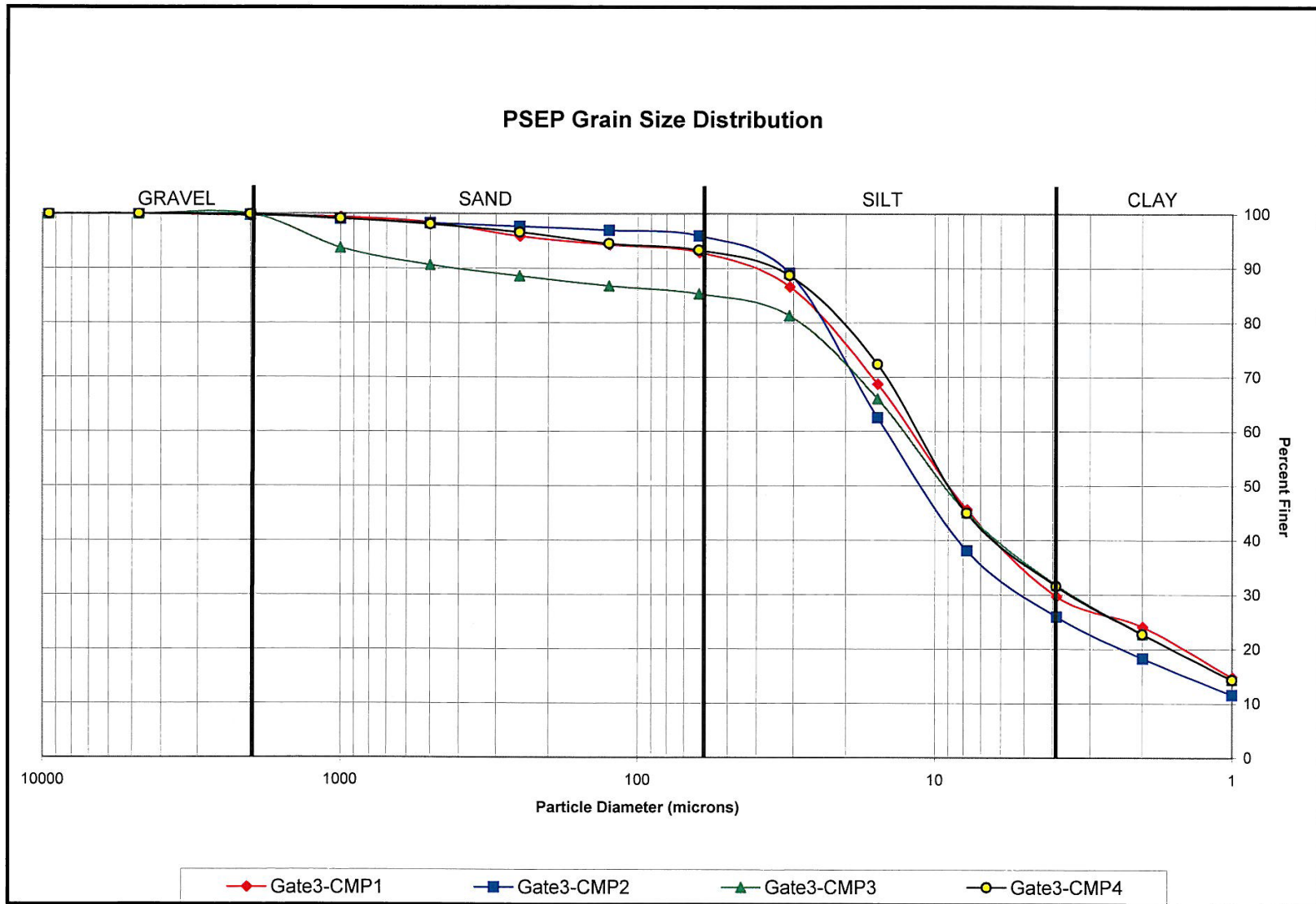

Port of Bellingham
 Gate 3 Floats F&G
 Bellingham, Washington

**Grain Size Distribution
 Samples CMP1 Through CMP4**

Figure
A-1



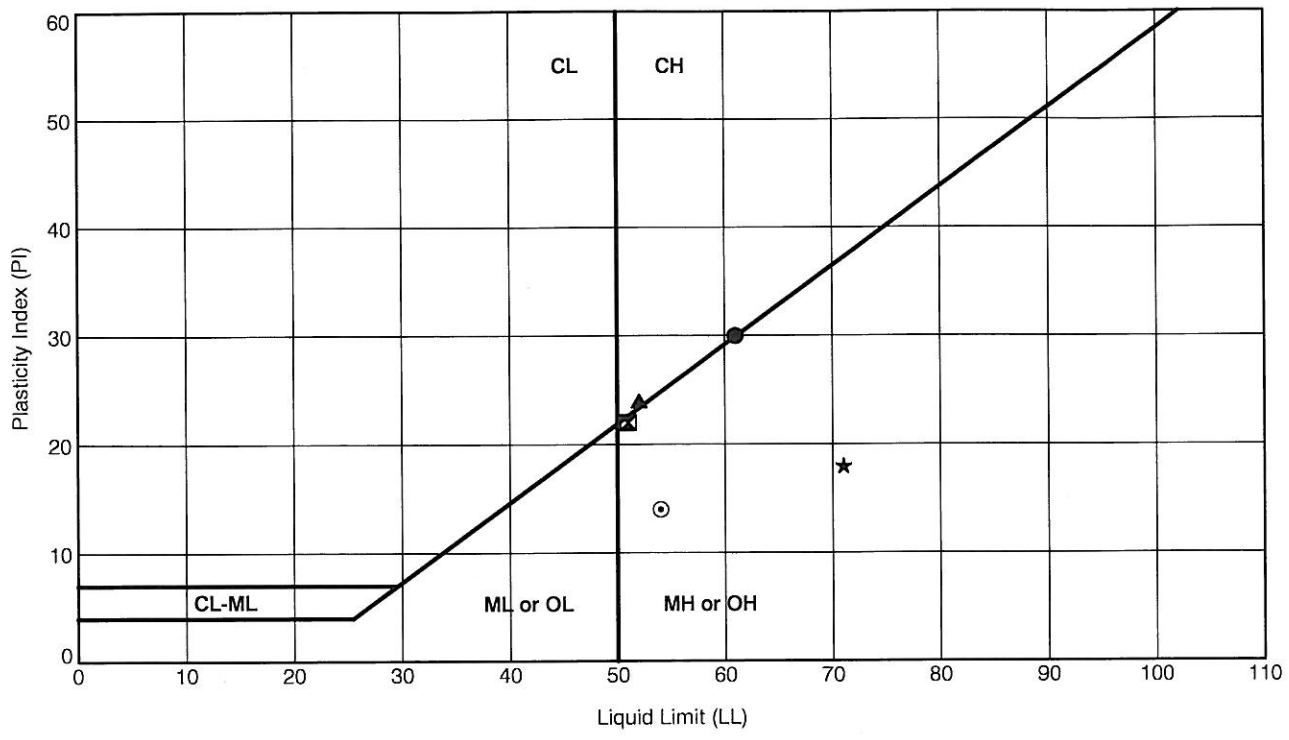

ATTERBERG LIMIT TEST RESULTS

Symbol	Exploration Number	Sample Number	Depth (ft)	Liquid Limit (%)	Plastic Limit (%)	Plasticity Index (%)	Natural Moisture (%)	Soil Description	Unified Soil Classification
●	DM(1)	Untreated	0	61	31	30		Dredge Material - Unamended	MH
⊠	DM(2)	Untreated	0	51	29	22		Dredge Material - Unamended	MH
▲	DM(3)	Untreated	0	52	28	24		Dredge Material - Unamended	MH
★	DM(3)	Cement	0	71	53	18		Dredge Material - Amended - 7.5% Cement	MH
⊙	DM(3)	Fly Ash C	0	54	40	14		Dredge Material - Amended - 20% Fly Ash C	MH

ASTM D 4318 Test Method

053097.051.051 2/17/11 N:\PROJECTS\053097.051.GPJ ATTERBERG LIMITS FIGURE



Port of Bellingham - Gate 3
Bellingham, WA

Plasticity Chart

Figure
A-2

053097.051.051_2/17/11 N:\PROJECTS\053097.051.051.GPJ COMPACTION FIGURE (PARABOLA) LOW RANGE

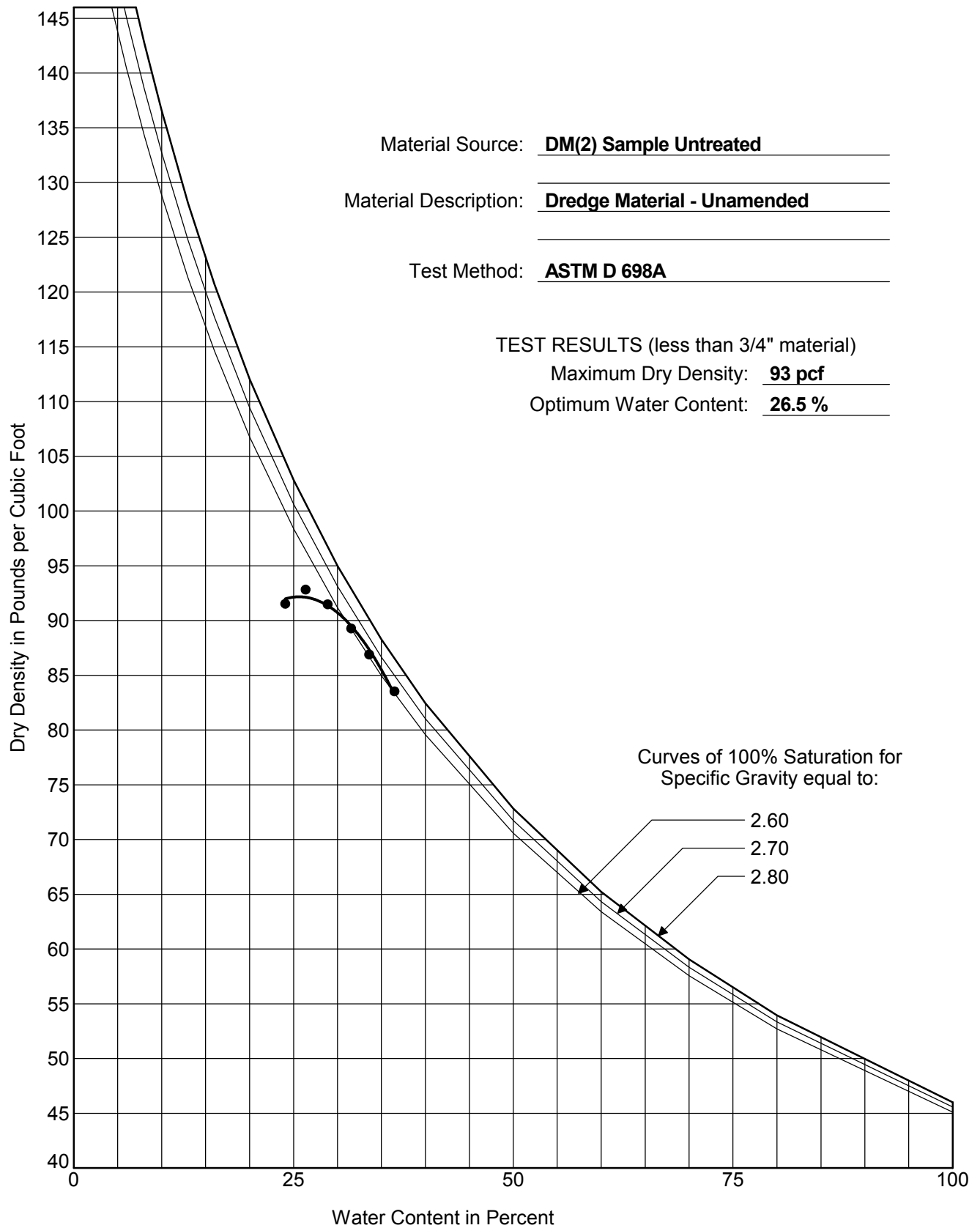

Port of Bellingham - Gate 3
Bellingham, WA

Moisture-Density Relationship

Figure
A-3

053097.051.051_2/17/11 N:\PROJECTS\053097.051.051.GPJ COMPACTION FIGURE (PARABOLA) LOW RANGE

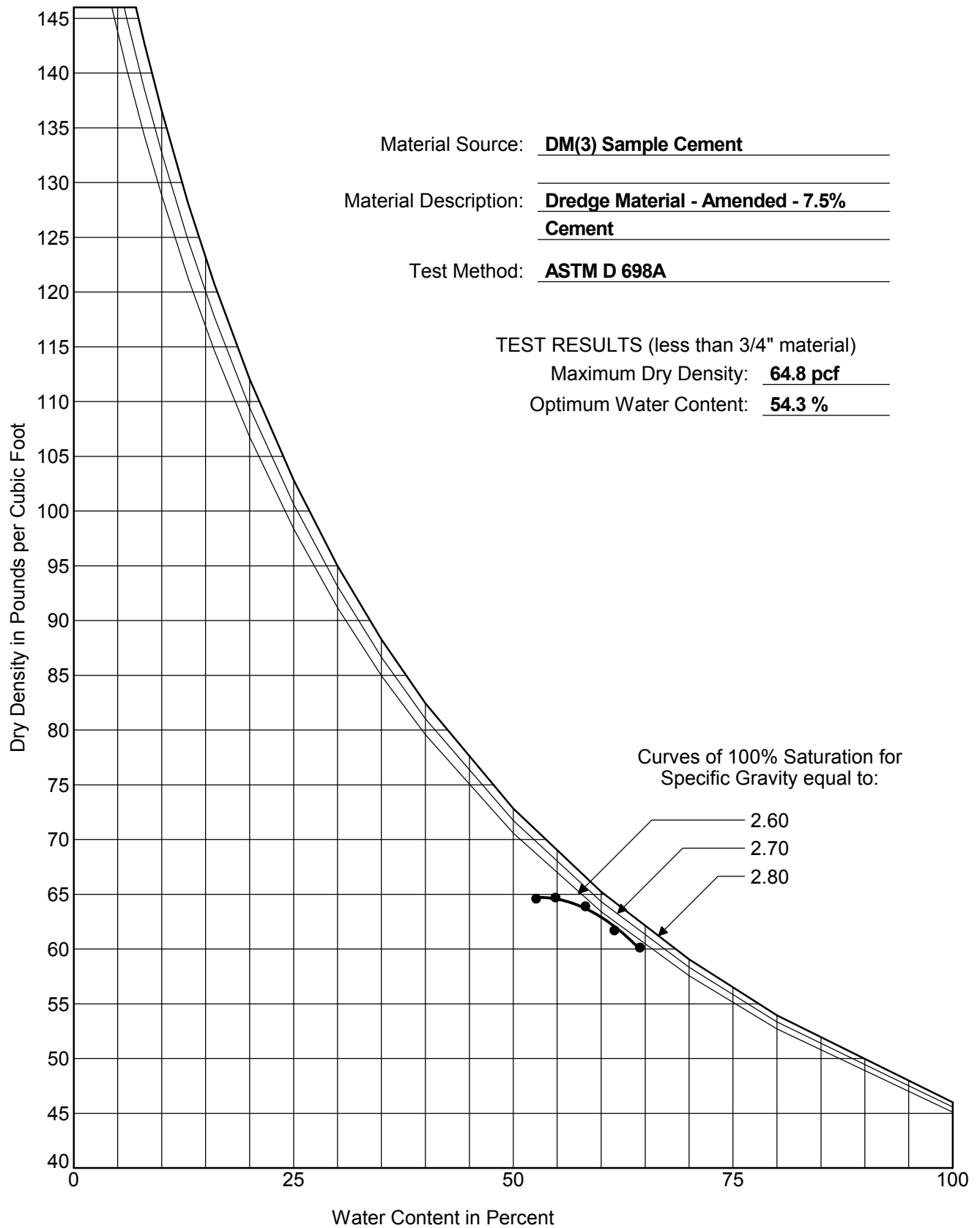

053097.051.051_2/17/11 N:\PROJECTS\053097.051.051.GPJ COMPACTION FIGURE (PARABOLA) LOW RANGE

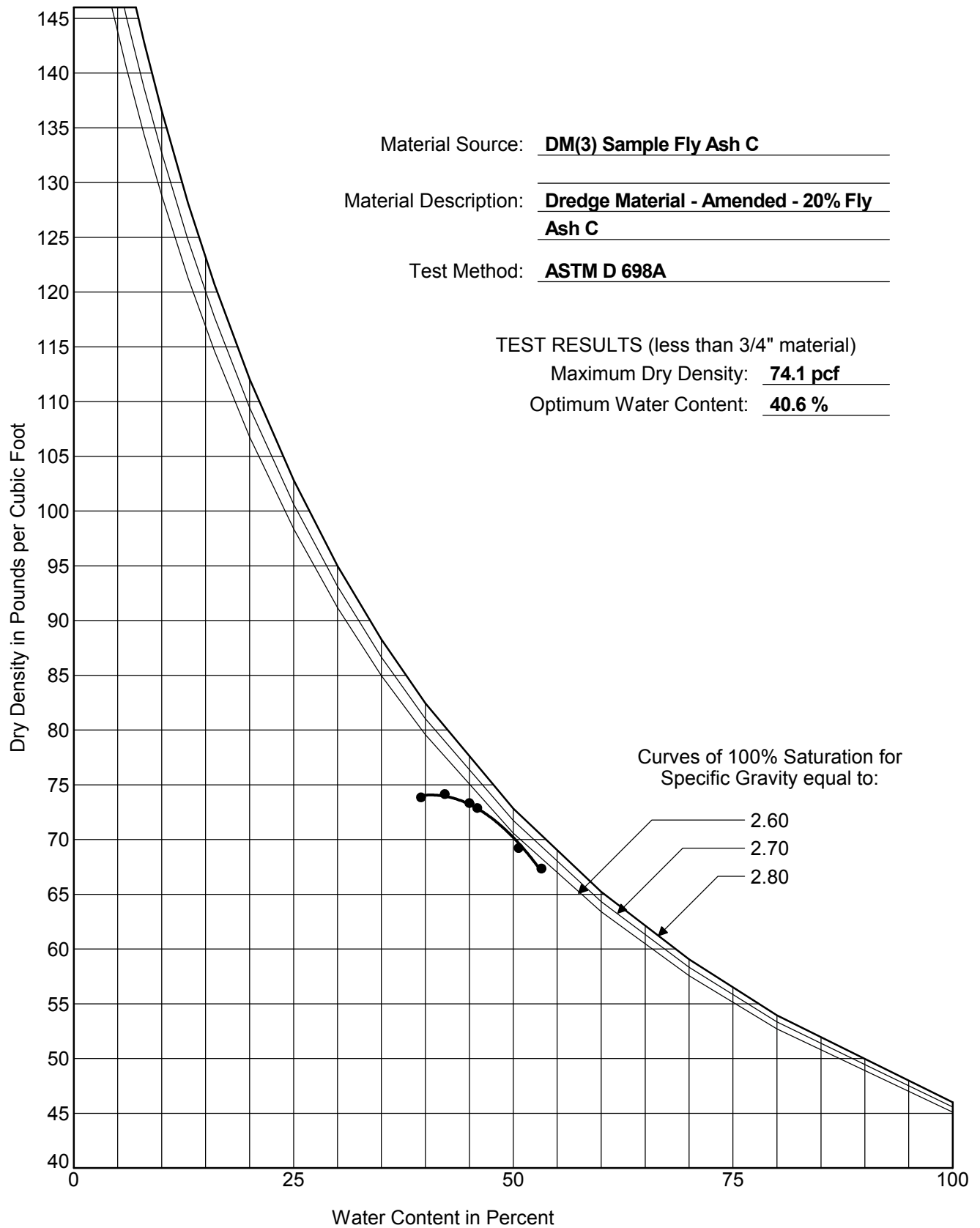

053097.051.051 2/16/11 N:\PROJECTS\053097.051.GPJ COMPACTION FIGURE (PARABOLA) LOW RANGE

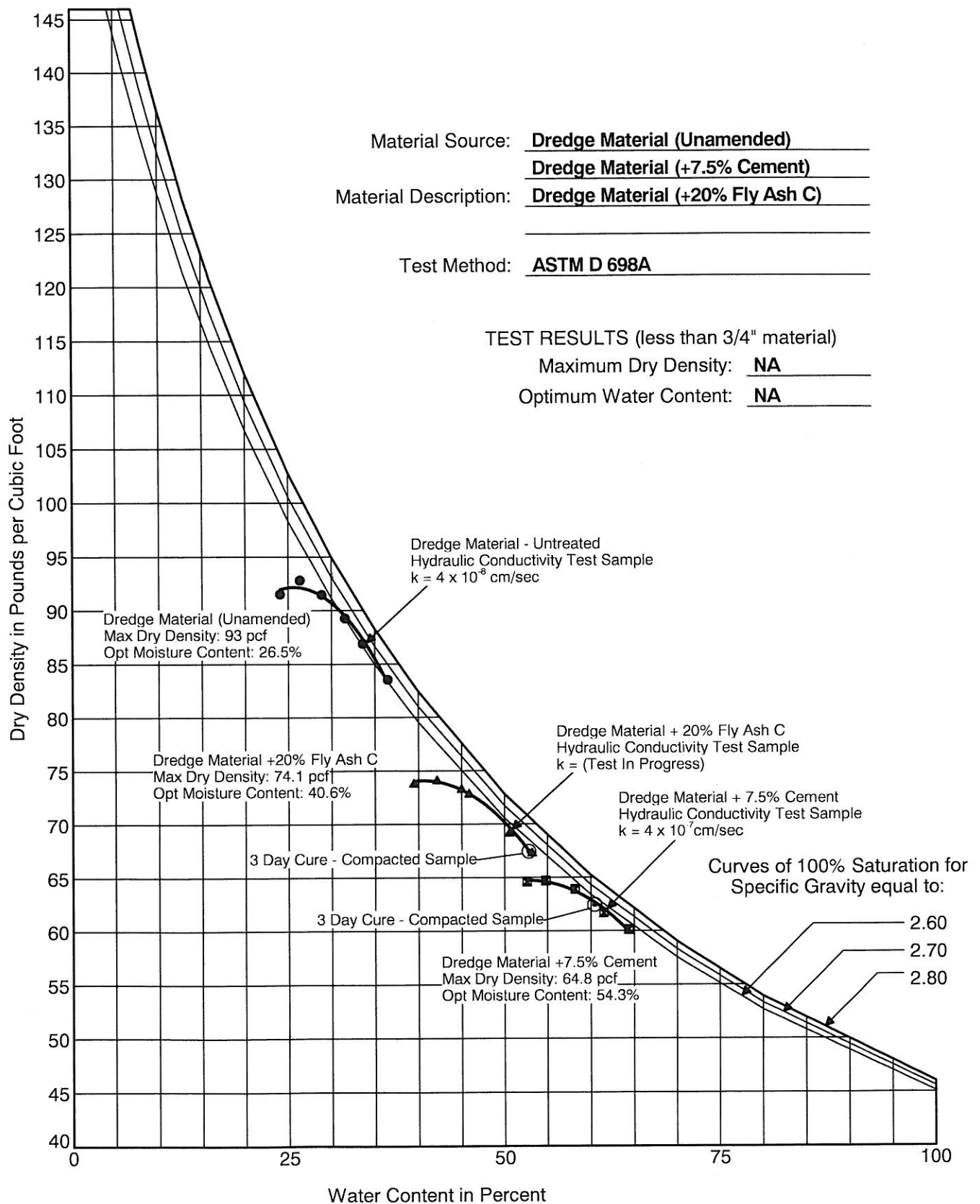

Port of Bellingham - Gate 3
 Bellingham, WA

Moisture-Density Relationship

Figure
A-6

**TABLE A-1
SUMMARY OF BENCH SCALE ADMIXTURE TESTS
CORNWALL AVENUE LANDFILL INTERIM ACTION
BELLINGHAM, WASHINGTON**

Test Phase	Admixture and Percent by Wet (Dry) Weight of DM	Notes / Observations	
Round 1	Fly Ash C	5.6 (10)	<ul style="list-style-type: none"> Not workable after 2 days
		11.1 (20)	<ul style="list-style-type: none"> Not workable after 2 days
		16.7 (30)	<ul style="list-style-type: none"> Not workable at mixing or after 2 hours At 1 day, feels more workable and appears "soil-like" At 2 days, feels workable and more "soil-like" but too wet to compact
		22.2 (40)	<ul style="list-style-type: none"> Not workable after 1 hour At 1 day, requires moderate finger pressure to break mixture into smaller pieces Feels relatively dry with properties similar to soil at optimum moisture, compactable
	50/50	5.6 (10)	<ul style="list-style-type: none"> Workable at mixing, but too wet to compact At 2 days, too wet to compact, appears "soil-like", breaks with little finger pressure
		11.1 (20)	<ul style="list-style-type: none"> Not workable at mixing but appears stackable At 1 hour, appears workable, appears near the liquid limit At 1 hour, mixture breaks apart with very little finger pressure
		16.7 (30)	<ul style="list-style-type: none"> Similar to 20 % 50/50 mix, but slightly drier Too wet to compact
	CKD	5.6 (10)	<ul style="list-style-type: none"> Not workable after 2 days
		11.1 (20)	<ul style="list-style-type: none"> Not workable after 2 days
		16.7 (30)	<ul style="list-style-type: none"> Not workable after 3 days
	Lime	5.6 (10)	<ul style="list-style-type: none"> Not workable after 1 day
		11.1 (20)	<ul style="list-style-type: none"> Fast-acting, workable at mixing but not compactable Generates heat and odor within about 1 minute of mixing
		16.7 (30)	<ul style="list-style-type: none"> Fast-acting, workable and "soil-like" at mixing Generates heat, odor, and smoke within about 1 minute of mixing No additional improvement observed after several days
	LKD	5.6 (10)	<ul style="list-style-type: none"> Not workable but possibly stackable (too wet)
		11.1 (20)	<ul style="list-style-type: none"> Not workable but possibly stackable (too wet)
16.7 (30)		<ul style="list-style-type: none"> Workable and stackable, but too wet to compact 	
Fly Ash F	11.1(20)	<ul style="list-style-type: none"> Not workable, appears worse than without the admixture. 	
Round 2	Type I/II Cement	5 (9)	<ul style="list-style-type: none"> Not workable at mixing Workable / Stackable after about 2 to 4 hours of mixing Mixture is friable and breaks apart easily with little finger pressure at 1 day Mixture is friable and breaks apart with moderate finger pressure at 3 days
		7.5 (13.5)	<ul style="list-style-type: none"> Not workable at mixing Workable and mixture breaks apart easily at about 2 to 4 hours Mixture appears friable at about 4 hours Mixture feels crumbly and requires low to moderate finger pressure to break at 1 day Mixture compacts to 96% of Standard Proctor at 6% over optimum at 3 days
		10 (18)	<ul style="list-style-type: none"> Not workable at mixing Workable / Stackable after about 2 to 4 hours of mixing Mixture is friable and breaks apart with moderate finger pressure at 1 day Mixture is hard and difficult to break using finger pressure at 3 days
		15 (27)	<ul style="list-style-type: none"> Not workable at mixing Mixture is workable but not compactable at about 1 hour Mixture will crumble / friable at 4 hours Mixture is hard and cannot break apart with finger pressure at 1 day
	Fly Ash C	10 (18)	<ul style="list-style-type: none"> Not workable after 1 day
		15 (27)	<ul style="list-style-type: none"> Not workable at mixing Workable, but still too wet to compact at 2 days
		17.5 (31.5)	<ul style="list-style-type: none"> Workable but not compactable at mixing Feels similar to 5% cement mixture at 1 day
		20 (36)	<ul style="list-style-type: none"> Not workable after about 2 hours Workable / stackable after about 2 to 4 hours Texture feels drier ("chalky") and possibly compactable (wet of optimum) after 1 day Feels similar to mixture with 7.5% cement at 2 days Mixture compacts to 91% of Standard Proctor at 12% over optimum at 3 days