

**Ecology Review Draft
Interim Action Completion Report
Spent Pot Lining Area
Former Kaiser Aluminum Property
3400 Taylor Way
Tacoma, Washington**

March 24, 2014

Prepared for

**Port of Tacoma
Tacoma, Washington**



130 2nd Avenue South
Edmonds, WA 98020
(425) 778-0907

TABLE OF CONTENTS

	<u>Page</u>
1.0 INTRODUCTION	1-1
1.1 SITE LOCATION AND HISTORY	1-1
1.1.1 Site Physical Conditions	1-2
1.1.2 Site Environmental Conditions	1-2
1.2 PURPOSE AND DESCRIPTION OF THE INTERIM ACTION	1-3
2.0 INTERIM ACTION CONSTRUCTION SUMMARY	2-1
2.1 PERMITTING AND REGULATORY REQUIREMENTS	2-2
2.2 MONITORING WELL DECOMMISSIONING	2-2
2.3 STORMWATER BEST MANAGEMENT PRACTICES	2-3
2.4 DEMOLITION ACTIVITIES	2-3
2.5 EXCAVATION ACTIVITIES	2-4
2.6 SPL MATERIAL DISPOSAL	2-5
2.7 BACKFILLING, GRADING, AND SITE RESTORATION	2-6
2.8 COMPLIANCE MONITORING	2-6
2.8.1 Protection Monitoring	2-6
2.8.2 Performance Monitoring	2-6
2.8.2.1 Confirmation Soil Sampling	2-7
2.8.2.2 Construction Quality Assurance	2-7
2.8.3 Confirmation Monitoring	2-8
2.9 INTERIM ACTION DESIGN MODIFICATIONS	2-8
3.0 USE OF THIS REPORT	3-1
4.0 REFERENCES	4-1

FIGURES

<u>Figure</u>	<u>Title</u>
1	Vicinity Map
2	Site Plan with Historical Site Features
3	SPL Area with Site Features
4	Planned vs. Actual SPL Area Excavation Limits
5	Performance Monitoring Soil Sampling Grid Layout

TABLES

<u>Table</u>	<u>Title</u>
1	Waste Disposal Summary
2	Pot Dumping Slab Sub-Soil Analytical Data
3	Surficial Soil Stockpile Analytical Data
4	Performance Monitoring Soil Analytical Data

APPENDICES

<u>Appendix</u>	<u>Title</u>
A	Selected Site Photographs
B	Permits/Approvals and SEPA Documentation
C	Interim Action Construction Drawings
D	As-Built Drawings
E	New Groundwater Monitoring Well Logs
F	Analytical Laboratory Reports
G	Waste Disposal Records

DRAFT

1.0 INTRODUCTION

This interim action construction completion report documents the successful implementation of an interim action at the Spent Pot Lining (SPL) Area at the former Kaiser Aluminum property (Site) by the Port of Tacoma (Port). The Site is located at 3400 Taylor Way in Tacoma, Washington, as shown on Figure 1. The interim action at the SPL Area was implemented to remove SPL zone material and associated contaminated soil with concentrations of constituents greater than the site specific cleanup levels developed and presented in the Final Remedial Investigation/Feasibility Study (RI/FS) report (Landau Associates 2012). For the purposes of this interim action, SPL zone material refers to the zone of SPL and other carbon-containing material mixed with soil and other waste materials present in the SPL Area; associated contaminated soil refers to soil within about 0.5 feet (ft) above and up to 0.5 ft below the SPL zone material. The SPL zone material and associated contaminated soil was disposed off site as Corrective Action Management Unit (CAMU)-eligible waste at a permitted hazardous waste landfill (WAC 173-303-646920).

Site plans from 2005 and 2010 showing the SPL Area are presented on Figures 2 and 3. A summary of background information on Site conditions and the design of the interim action are presented in the SPL Area Interim Action Work Plan (Interim Action Work Plan; Landau Associates 2013a).

The interim action was conducted in accordance with the Washington State Model Toxics Control Act (MTCA) under Agreed Order No. DE-5698 between the Port and the Washington State Department of Ecology (Ecology). The interim action was completed in advance of selection of the final cleanup action for the Site to improve the efficacy of the final cleanup in accordance with Article VII.D of the Agreed Order, and to support Port development plans in the vicinity of the SPL Area. The interim action was designed and executed in accordance with WAC 173-340-430.

1.1 SITE LOCATION AND HISTORY

The Site encompasses approximately 96 acres of the Blair Hylebos Peninsula in Tacoma, Washington. The Hylebos Waterway is located northeast of the Site and the Blair Waterway is located to the southwest (Figure 1). From 1941 to 1947, the Department of Defense built and operated an aluminum smelter at the Site. In 1947, Kaiser Aluminum & Chemical Corporation (Kaiser Aluminum) purchased the Site and operated the aluminum production facility until 2001. In 2002, Kaiser Aluminum closed the plant and, in 2003, the Port purchased the smelter property from Kaiser Aluminum for redevelopment. Between 2003 and 2010, the Port demolished the smelter complex, shipped thousands of tons of waste to approved disposal or treatment facilities, and placed a 2- to 6-ft-thick layer of structural fill on approximately 80 of the 96 acres.

The SPL Area is located within the eastern portion of the Site, as shown on Figures 2 and 3. The SPL Area consists of a portion of the Site which was historically used to dismantle reduction cells and temporarily store SPL and potroom duct dust. From 1943 to 1967, the area was not paved and, for most of the earlier part of this period, the area was not at its present grade. In 1967, the SPL management facility was constructed in the SPL Area, and included a 19,500 square foot (ft²) concrete pad, runoff sump, storage tanks, and associated piping. The approximate area that the SPL management facility encompassed is shown on Figures 2 and 3. From 1967 until 1985, SPL was temporarily stored on the SPL management facility pad until enough SPL was accumulated for shipment to an offsite disposal facility. During the latter portion of this time of operation, SPL was considered a state-only waste.

A Part A Dangerous Waste Permit application identifying the SPL management facility as a regulated unit for storage of SPL prior to offsite shipment and disposal was submitted in about 1980 (Kaiser Aluminum 1980). In December 1985, Kaiser Aluminum removed all waste from the SPL management facility and ceased use of the facility, replacing it with an indoor facility (Building 65; Kaiser Aluminum 2003). Subsequently, Kaiser Aluminum reverted to generator status for management of SPL zone material (Landau Associates 2004). After the SPL management facility had ceased operation, SPL was listed as a federal hazardous waste (K088), primarily due to the presence of cyanide. The SPL management facility, a Resource Conservation and Recovery Act (RCRA) regulated unit, was decommissioned by Kaiser Aluminum in late 2002, per an Ecology-reviewed closure plan (Landau Associates 2003), and Ecology approved the closure in 2011 (Ecology 2011a,b). Additional information regarding the SPL Area history is presented in the Compilation Report (Landau Associates 2011) and the final RI/FS report (Landau Associates 2012).

1.1.1 SITE PHYSICAL CONDITIONS

The geology and hydrogeology of the Site is summarized in Section 8.1 of the final RI/FS report and in Section 2.1 of the Interim Action Work Plan

1.1.2 SITE ENVIRONMENTAL CONDITIONS

The results of the RI combined with the results from the 2008 supplemental investigation, earlier SPL Area investigations, and an investigation conducted in late 2008 as part of the now-cancelled Blair Hylebos Peninsula Terminal Redevelopment Project, were used to evaluate the nature and extent of SPL zone materials present in and adjacent to the SPL Area subsurface and to evaluate the nature and extent of impact to soil and groundwater by these SPL zone materials. Environmental conditions at the SPL Area prior to implementation of the interim action are summarized in Section 2.2 of the Interim Action Work Plan.

DRAFT

1.2 PURPOSE AND DESCRIPTION OF THE INTERIM ACTION

The purpose of the interim action was to permanently remove (through excavation and offsite disposal) SPL zone material and associated contaminated soil within the SPL area with concentrations greater than the cleanup levels established in the final RI/FS. Based on the data collected during the RI/FS, the following interim action soil cleanup levels were established for carcinogenic polycyclic aromatic hydrocarbons (cPAHs):

Constituent	Interim Action Soil Cleanup Level
CPAHs (µg/kg) Method SW8270D	
Benzo(a)anthracene	130
Chrysene	140
Benzo[a]pyrene	350
Indeno(1,2,3-c,d)pyrene	1,200
Dibenz(a,h)anthracene	640
Total Benzofluoranthenes	440
TEQ	2,000

The interim action also removed the source of contamination to groundwater and will therefore limit the potential for groundwater with contaminant concentrations greater than the cleanup levels to migrate off site. In addition, it has substantially reduced the cost of the final remedy by removing the SPL zone material and associated contaminated soil that would likely need to be addressed as part of the final cleanup action.

2.0 INTERIM ACTION CONSTRUCTION SUMMARY

Interim action construction activities were implemented during the summer and fall of 2013 by the Port's selected contractor, Clearcreek Contractors (Clearcreek) of Everett, Washington and its subcontractor, Rhine Demolition (Rhine) of Tacoma, Washington. Groundwater monitoring well decommissioning and installation activities were conducted by Holocene Drilling Inc. (Holocene) of Puyallup, Washington under subcontract to Landau Associates.

As summarized in Table 1, a total of 38,837.94 tons of SPL zone material and associated contaminated soil (SPL material) was removed and disposed at the Waste Management Subtitle C hazardous waste landfill in Arlington, Oregon. A summary of the interim action construction activities is presented in the following sections. Selected photographs of interim action construction activities are presented in Appendix A.

The SPL Area interim action construction activities were conducted along the following timeline:

- June 2013
 - Five groundwater monitoring wells within and near the SPL Area are decommissioned.
- July 2013
 - Temporary construction facilities are set up and temporary erosion and sedimentation control (TESC) measures are installed.
 - Begin demolition, removal, and rubblization of surficial concrete slabs and asphalt pavements within the SPL Area; a 39- by 60.5-ft section of heavily reinforced concrete about 5 ft thick was identified as the pot dumping slab located within the former SPL management facility.
- August 2013
 - Continue demolition, removal, and rubblization of concrete slabs and asphalt pavements.
 - Begin excavation, stockpiling, hauling, and disposal of SPL material.
 - Begin confirmation soil sampling within the base of excavated grids.
- September 2013
 - Continue excavation, stockpiling, hauling, and disposal of SPL material.
 - Continue confirmation soil sampling within the base of excavated grids.
 - Continue rubblization of concrete slabs and asphalt pavements.
 - Begin demolition and removal of the thick pot dumping slab.
- October 2013
 - Continue excavation, stockpiling, hauling, and disposal of SPL material.
 - Continue confirmation soil sampling within the base of excavated grids.
 - Complete demolition, removal, and rubblization of the thick pot dumping slab.

- Complete placement of rubblized concrete and asphalt as fill material in the former rectifier yard area.
- Begin relocation of the dredged soil stockpile to access underlying SPL material.
- November 2013
 - Complete excavation, stockpiling, hauling, and disposal of SPL material.
 - Complete confirmation soil sampling within the base of excavated grids.
 - Continue regrading of the dredged soil stockpile.
 - Begin site preparation for the wet season.
- December 2013
 - Complete regrading and hydroseeding of the dredged soil stockpile.
 - Complete construction of berms, ditches, and swales to promote stormwater drainage, and hydroseeding of selected areas around the SPL Area excavation.

2.1 PERMITTING AND REGULATORY REQUIREMENTS

The interim action was conducted in accordance with MTCA under Agreed Order No. DE-5698 between the Port and Ecology, and the Interim Action Work Plan that was approved by Ecology. Compliance with the State Environmental Policy Act (SEPA), Chapter 43.21C RCW, was achieved by conducting a SEPA review in accordance with applicable regulatory requirements, including WAC 197-11-268.

Permits and approvals obtained prior to implementing interim action activities included:

- CAMU-eligible waste approval letters from Ecology and Oregon Department of Environmental Equality
- Waste Management Notice of Profile Approval: OR321468
- National Pollutant Discharge Elimination System (NPDES) Construction Stormwater General Permit No. WAR127225.

The interim action was determined to be procedurally exempt from the requirements of the City of Tacoma Grading Permit and the City of Tacoma Stormwater Management Requirements. Permits and approvals acquired and the SEPA Checklist and Determination of Non-Significance (DNS) for the interim action project are included in Appendix B.

2.2 MONITORING WELL DECOMMISSIONING

Five groundwater monitoring wells (three shallow, one intermediate, and one deep well) were decommissioned in the SPL Area on June 18, 2013 to facilitate completion of the interim action excavation activities. All groundwater monitoring wells were decommissioned by Holocene. These included monitoring wells MW-B(S), MW-C(S), MW-C(I), MW-C(D), and MW-F(S), as shown on Figure 3. The

DRAFT

details of the monitoring well decommissioning are discussed in the *Technical Memorandum: Former Kaiser Aluminum Property Well Decommissioning, Rod Mill Area Closed Landfill and SPL Area Interim Actions*, dated November 18, 2013 (Landau Associates 2013b).

2.3 STORMWATER BEST MANAGEMENT PRACTICES

Prior to excavation activities, a stormwater pollution prevention plan (SWPPP) was prepared by the Port to document planned procedures designed to prevent stormwater pollution by controlling erosion of exposed soil. Best management practices (BMPs) were implemented by Clearcreek to prevent soil erosion and sediment transport during construction. BMPs included upgrading the existing construction entrance/exit; installing silt fencing to prevent sediment-laden water from leaving the Site; installing coir logs around the concrete drainage vault; plugging the pipe from the concrete drainage vault to prevent offsite discharge; installing/use of an automated wheel wash facility along the access road; covering soil stockpiles (as needed); and applying water and controlling vehicle operations to limit generation of fugitive dust.

2.4 DEMOLITION ACTIVITIES

Demolition, removal, and rubblization of surficial concrete slabs and asphalt-concrete pavements were conducted by Rhine in general accordance with the requirements of the Interim Action Work Plan and the project drawings and specifications. Any potentially contaminated soil that adhered to the demolition debris was removed by mechanical means in the SPL Area prior to being transported to the temporary material processing and stockpiling area established in the former Rod Mill Area. The demolished slabs and pavements were rubblized with a mechanical crusher and the resulting material was subsequently beneficially used as fill material within a portion of the former rectifier yard area.

During removal of the surficial concrete slabs in the former SPL management facility, a 39- by 60.5-ft section of heavily reinforced concrete about 5 ft thick was encountered below the area of the slab known to contain near-surface steel rail reinforcement. This thick concrete slab was subsequently identified as the former pot dumping slab (see Figure 3). To determine if the pot dumping slab needed to be removed, soil samples were collected below the north side of the slab (samples TPN-1 and TPN-2) and the east side of the slab (TPE-1 and TPE-2). Samples TPN-1 and TPE-1 were collected from a suspect dark gray layer observed directly below the slab's granular subgrade layer, and samples TPN-2 and TPE-2 were collected from the underlying, visually cleaner soil layer. The analytical results for these soil samples are presented in Table 2 and confirmed that the dark gray layer was SPL zone material and the underlying soil did not exceed the interim action soil cleanup levels. Rhine later mobilized heavier equipment and demolished/removed the former pot dumping slab to allow excavation of the underlying contaminated materials.

DRAFT

The buried storm drain piping connected to the concrete drainage vault in the SPL Area was cut and plugged with CDF about 4 ft from the fenceline along Taylor Way. The concrete piping and vault were demolished during soil excavation activities and the associated demolition debris was disposed off site along with the adjacent SPL material. Additionally, various buried utility conduits and piping encountered during soil excavation were also demolished and disposed off site along with the adjacent SPL material.

Note that the concrete foundations for the former water tower, laboratory building, and storeroom were exposed following relocation of portions of the existing dredged soil stockpile located along the west side of the SPL Area (see Figures 3 and 4). Based on visual observations of the soil layers adjacent to and below these concrete foundation elements, the foundations were left in place following removal and disposal of the adjacent soil.

2.5 EXCAVATION ACTIVITIES

Interim action excavation activities were conducted by Clearcreek in general accordance with the requirements of the Interim Action Work Plan and the project Contract Documents. The interim action construction drawings are included in Appendix C. Excavation of the SPL material commenced on August 6, 2013 and was essentially completed by November 14, 2013.

Prior to excavation, the estimated extent of the SPL zone material to be removed was surveyed and staked in the field based on the limits shown on the interim action construction drawings; the originally planned excavation area was approximately 2.1 acres in size (see Figure 4). However, Landau Associates' personnel and Clearcreek operators used visual observations during excavation, followed by confirmation soil sampling, to determine the actual lateral and vertical extent of the final SPL excavation, which extended to the limits of the approximately 4.1 acre area shown on Figure 4 and the as-built drawings in Appendix D.

An initial attempt was made to remove and stockpile some of the visually cleaner near surface soil for potential reuse as backfill material. However, sampling and analysis indicated that most of the stockpiled soil exceeded cPAH cleanup levels (see results presented in Table 3). Accordingly, all of the surficial soil overlying the SPL zone material was removed and disposed along with the other excavated materials.

Excavation activities generally proceeded from north to south within the area adjacent to the dredged soil stockpile and then east to west in the area below the dredged soil stockpile. Construction observations and confirmation soil sampling during excavation identified conditions that required removal and disposal of a significantly greater volume/weight of material than estimated during project design. Site conditions encountered that resulted in the need for removal and disposal of a greater volume/weight of material included, but are not limited to:

- Presence of uneven layers of interbedded SPL material and fill soil that extended deeper and beyond the lateral extent identified during previous explorations

DRAFT

- Unidentified subsurface utility trenches that were backfilled with SPL material
- Presence of an apparent channel or drainage feature running below a portion of the SPL Area that was filled with coarse material impacted by SPL and other waste materials
- Discontinuous pockets and lenses of SPL material mixed with soil and other wastes that required removal and disposal of additional material
- Layers of SPL material that extended further west under the dredged soil stockpile than assumed during design
- Unanticipated wet weather conditions in September 2013 that resulted in a relatively rapid rise in groundwater levels and ponding of water within a relatively large portion of the SPL excavation area, and the need to excavate and dispose of wetter/heavier soil
- Presence of some zones of cobbly fill material and debris with a unit weight greater than anticipated during design
- SPL confirmation soil sampling grids that failed to achieve interim action cleanup levels for cPAHs that required additional soil removal.

The original design anticipated that only a few localized, deeper excavations would extend below groundwater level. However, as noted above, wet weather conditions during construction resulted in a rise in groundwater levels that resulted in a significant portion of the deeper excavations extending below groundwater level. The wetter excavated material was allowed to drain near the edge of the excavation to remove free liquids, and in some areas was mixed with absorbent materials (e.g., sawdust) prior to loading for disposal.

The originally estimated excavation volume was about 8,300 cubic yards (yd³); however, the SPL excavation volume is estimated at approximately 24,275 yd³ (based on the tonnage summarized in Section 2.6 and an assumed in-place unit weight of 1.6 tons/yd³).

2.6 SPL MATERIAL DISPOSAL

Excavated SPL material was temporarily stockpiled along the edge of the excavations, and was subsequently transferred into lined trucks and transported under appropriate hazardous waste manifests for disposal at the Waste Management Subtitle C landfill in Arlington, Oregon. Trucking and disposal records are provided in Appendix F and summarized in Table 1.

The originally estimated weight of SPL material to be removed for disposal was 12,500 tons; however, a total of 38,837.94 tons of material from the SPL Area was disposed at the Waste Management hazardous waste landfill between August 6, 2013 and November 14, 2013 (see the waste disposal summary in Table 1). In addition, approximately 1,600 pounds of residual sludge from the automated wheel wash facility was drummed and sent to Waste Management for solidification and landfilling. Additional trucking and disposal records are provided in Appendix G.

DRAFT

2.7 BACKFILLING, GRADING, AND SITE RESTORATION

Due to SPL Area excavation activities extending into November 2013 and the presence of ponded water within a significant portion of the excavated area, the Port decided to leave the excavation open during the wet season and defer backfilling and grading of the SPL Area excavation until the summer/fall of 2014.

The SPL Area was prepared for the wet season by:

- Maintaining the silt fencing previously installed along the Taylor Way fenceline
- Regrading and hydroseeding the dredged soil stockpile
- Constructing a surface water diversion berm and swale between the southern edge of the excavation area and the site access road, and excavating a drainage diversion swale across the access road to the Rod Mill Area drainage feature, to limit accumulation of stormwater runoff in the excavated area
- Hydroseeding of selected exposed soil areas around the SPL Area excavation.

It is currently anticipated that future excavation backfilling will include placement of quarry spalls to raise the lower portion of the excavation above the water table, followed by placement/compaction of dredged soil from the adjacent stockpile to achieve desired backfill grades.

2.8 COMPLIANCE MONITORING

Compliance monitoring included the following protection, performance, and conformational monitoring activities to assure the effectiveness of the interim action.

2.8.1 PROTECTION MONITORING

Protection monitoring included worker health and safety activities related to interim action construction, as well as certain provisions for protection of the general public. Worker health and safety was addressed through implementation of a project-specific health and safety plans prepared by Clearcreek and Landau Associates, worker protection provisions, dust suppression measures, air and dust monitoring, and use of an automated vehicle wheel wash facility at the Site entrance.

2.8.2 PERFORMANCE MONITORING

Performance monitoring consisted of collection and analysis of confirmation soil samples to demonstrate that the interim action soil cleanup levels were achieved, and construction quality assurance (CQA) monitoring to confirm that the interim action was conducted in conformance with the project construction drawings and specifications.

2.8.2.1 Confirmation Soil Sampling

Confirmation soil sampling was conducted in general accordance with the Interim Action Work Plan; however, adjustments were made to the sampling grid layout, and the number of samples collected to better fit the pattern and constraints of the excavation activities.

The base of the SPL Area excavation was divided into 68 sampling grids as shown on Figure 5. Confirmation soil samples from grids with a base above groundwater level were a composite from 4 to 6 sub-samples collected from about 0-6 inches below ground surface (BGS), while confirmation soil samples from grids with a base below groundwater level were collected using an excavator bucket to obtain a representative base soil sample. With Ecology's concurrence, sidewall samples were not collected because the sides of the grids typically graded into adjacent grids or tapered up to the surrounding surface grade at the perimeter of the excavation area.

All soil samples were delivered to Analytical Resources Inc. (ARI) analytical laboratory in Tukwila, Washington under Chain of Custody procedures. The samples were analyzed for cPAHs (using EPA Method SW8270D). Quality assurance and data validation were conducted by Landau Associates on the data packages from the laboratory, and no data was rejected; the analytical laboratory reports are included in Appendix F.

The confirmation soil sampling results are presented in Table 4 and were compared directly to the interim action soil cleanup levels. Note that the initial sample results for 10 of the 68 grids (samples SPL-7, SPL-14, SPL-18, SPL-24, SPL-29, SPL-30, SPL-53, SPL-54, SPL-62, and SPL-68) exceeded the soil cleanup levels for one or more cPAHs. Additional soil removal was conducted within these 10 grids, and subsequent resampling and analysis confirmed that the soil cleanup levels were achieved, except for grid 14 where additional excavation and a third round of sampling and analysis was required to meet soil cleanup levels. As shown in Table 4, the results of confirmation soil sampling along the base of the final SPL Area excavation demonstrate compliance with the interim action soil cleanup levels.

2.8.2.2 Construction Quality Assurance

CQA monitoring included construction observations to confirm that the interim action was constructed consistent with the intent of the Interim Action Work Plan and the project construction drawings and specifications. Interim action construction activities were observed and documented by representatives of the Port and Landau Associates.

Physical testing conducted by Clearcreek's soil testing laboratory (Krazan and Associates) included a limited amount of grain size and compaction testing of the dredged soil stockpile material; however, as previously discussed, placement of compacted backfill within the SPL Area excavation has been deferred until the summer/fall of 2014.

DRAFT

2.8.3 CONFIRMATION MONITORING

Confirmation monitoring will be conducted to confirm the effectiveness of the interim action, and will consist of a groundwater compliance monitoring program. This will include post-construction groundwater monitoring of two new shallow downgradient groundwater monitoring wells located near the property boundary adjacent to Taylor Way, in accordance with the Interim Action Work Plan and the *Technical Memorandum: Groundwater Monitoring Results and Recommendations, Former Kaiser Aluminum Property*, dated December 11, 2013 (Landau Associates 2013c).

The two new shallow downgradient groundwater monitoring wells (MW-SPL1 and MW-SPL2) were installed by Holocene on February 28, 2014. The locations of the two new monitoring wells are shown on Figure 5, and the associated well logs are presented in Appendix E. Well development was initially scheduled for March 14, 2014; however, a relatively high level of water ponding in the SPL Area excavation prevented proper vehicle and equipment access to the new monitoring wells. The monitoring wells are currently scheduled to be developed in the spring of 2014 prior to the first post-construction groundwater monitoring event.

As discussed in the above referenced Technical Memorandum, the Port proposes to collect groundwater samples following well development, with the samples analyzed for cPAHs, total cyanide, and weak acid dissociable (WAD) cyanide. After analytical results from the initial monitoring event have been received, the Port will discuss the appropriate future monitoring with Ecology.

2.9 INTERIM ACTION DESIGN MODIFICATIONS

Several significant design modifications were made during implementation of the SPL Area interim action, including the following:

- Construction observations during excavation identified conditions that required removal and disposal of a significantly greater volume/weight of material within a larger portion of the SPL Area than estimated during project design. Site conditions encountered that resulted in the need for removal and disposal of a greater amount of material are summarized in Section 2.5. The originally estimated excavation volume was about 8,300 yd³; however, the final SPL excavation volume was estimated to be approximately 24,275 yd³. The originally estimated weight of SPL material to be removed was 12,500 tons; however, the total weight of SPL material disposed at Waste Management's Arlington landfill was 38,837.94 tons.
- Due to SPL Area excavation activities extending into November 2013 and the presence of ponded water within a significant portion of the excavated area, the Port decided to leave the excavation open during the wet season and defer backfilling and grading of the SPL Area excavation until the summer/fall of 2014. Ecology approved this change during a site visit with the Port on November 19, 2013.

DRAFT

3.0 USE OF THIS REPORT

This Interim Action Completion Report has been prepared for the use of the Port of Tacoma and the Washington State Department of Ecology for specific application to the SPL Area Interim Action project at the Former Kaiser Aluminum Site. None of the information, conclusions, and recommendations included in this document can be used for any other project without the express written consent of Landau Associates. Further, the reuse of information, conclusions, and recommendations provided herein for extensions of the project or for any other project, without review and written authorization by Landau Associates, shall be at the user's sole risk. Landau Associates warrants that within the limitations of scope, schedule, and budget, our services have been provided in a manner consistent with that level of care and skill ordinarily exercised by members of the profession currently practicing in the same locality under similar conditions as this project. We make no other warranty, either express or implied.

This report has been prepared under the supervision and direction of the following key staff. We hereby conclude that, to the best of our knowledge, the interim action construction activities summarized in this report have been satisfactorily completed in substantial compliance with the Interim Action Work Plan, the construction drawings and specifications, and other project related documents.

LANDAU ASSOCIATES, INC.

Jessica C. Stone
Senior Scientist



David A. Fischer, P.E.
Principal

DAP/JCS/kes

DRAFT

4.0 REFERENCES

- Ecology. 2011a. Letter: *Approval of RCRA Waste Storage Building and Spent Potliner Management Area Closure Plans – EPA ID # 001882984*. From Paul Skyllingstad, Industrial Section, Washington State Department of Ecology, to William Evans, Port of Tacoma. August 31.
- Ecology. 2011b. Letter: *Clean Closure Approval – Building # 65 and Spent Potlining Management Area – EPA ID # WAD 001882984*. From Paul Skyllingstad, Industrial Section, Washington State Department of Ecology, to William Evans, Port of Tacoma. September 1.
- Kaiser Aluminum. 2003. Letter: *Kaiser Tacoma Former Spent Potlining Management Facility*. From Mr. Bernard P. Leber, Jr., Kaiser Aluminum to Mr. Eric Oie, Department of Ecology. February 17.
- Kaiser Aluminum. 1980. *Part A Hazardous Waste Permit Application*. October 30.
- Landau Associates. 2013a. *Final SPL Area Interim Action Work Plan, Former Kaiser Aluminum Property, 3400 Taylor Way, Tacoma, Washington*. Prepared for the Port of Tacoma. February 28.
- Landau Associates. 2013b. Technical Memorandum from Colette Gaona and Dave Fischer, Landau Associates, to Bill Evans, Port of Tacoma. Re: *Former Kaiser Aluminum Property Well Decommissioning, Rod Mill Area Closed Landfill and SPL Area Interim Actions, Port of Tacoma, Tacoma, Washington*. November 13.
- Landau Associates. 2013c. Technical Memorandum from Colette Gaona and Kristy Hendrickson, Landau Associates, to Bill Evans, Port of Tacoma. Re: *Groundwater Monitoring Results and Recommendations, Former Kaiser Aluminum Property, 3400 Taylor Way, Tacoma, Washington*. December 11.
- Landau Associates. 2012. *Final Remedial Investigation/Feasibility Study, Former Kaiser Aluminum Property, 3400 Taylor Way, Tacoma, Washington*. Prepared for the Port of Tacoma. August 23.
- Landau Associates. 2011. *Compilation Report, Former Kaiser Aluminum Property, 3400 Taylor Way, Tacoma, Washington*. Prepared for Port of Tacoma. November 30.
- Landau Associates. 2004. Letter Report: *Groundwater Monitoring Report, June and July 2004, Former Kaiser Aluminum & Chemical Corporation, Former Spent Potlining Management Area*. Prepared for the Port of Tacoma. November 19.
- Landau Associates. 2003. *Decommissioning and Concrete Pad Sampling, Former Spent Potlining Facility, Kaiser Aluminum & Chemical Corp., Tacoma, Washington*. April 30.

DRAFT

G:\Projects\118\03\01\060\Completion Report\Figure 1 Vicinity Map 2013.mxd 12/20/2013 NAD 1983 StatePlane Washington North FIPS 4601 Feet

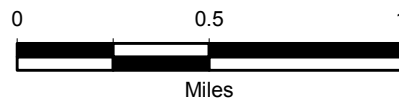
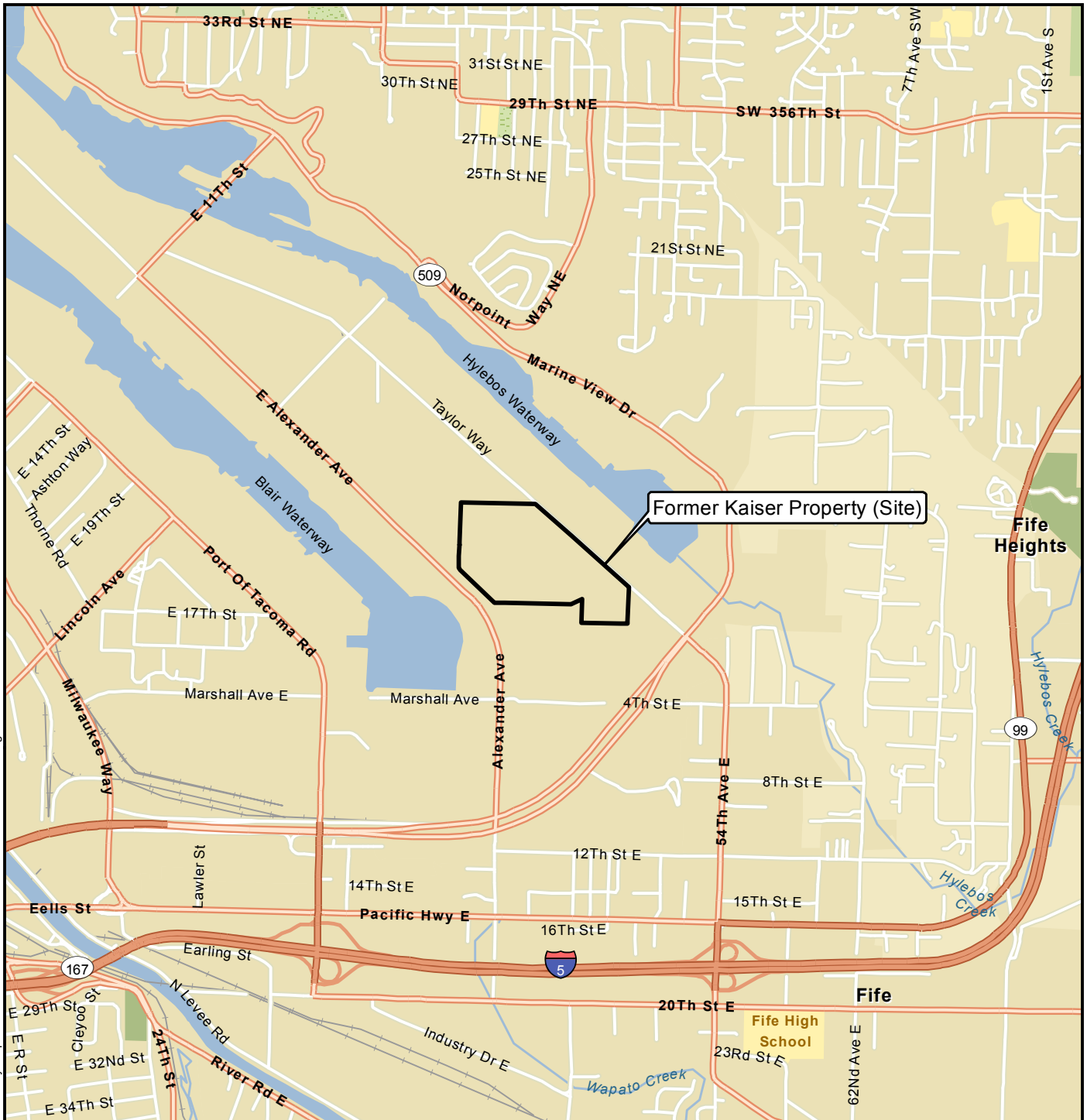

Data Source: Esri 2012



Interim Action
 Completion Report
 Spent Pot Lining Area
 Tacoma, Washington

Vicinity Map

Figure
 1



Legend

 Site Boundary

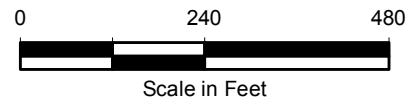

Data Source: Bing Aerials 2005; Pierce County Assessor

Interim Action
Completion Report
Spent Pot Lining Area
Tacoma, Washington

**Site Plan with
Historical Site Features**



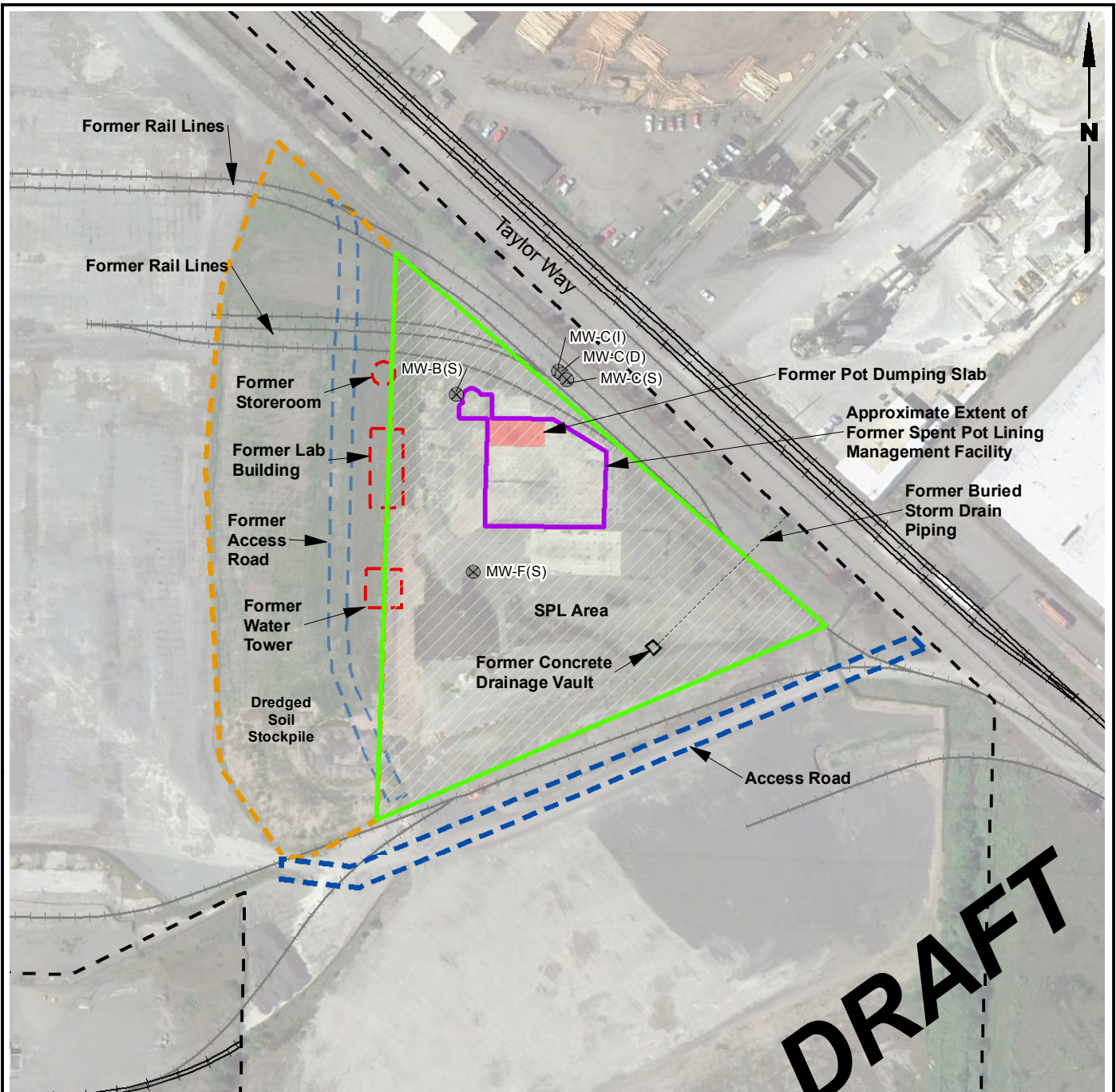

Figure
2

G:\Projects\1180303\010\060\Completion Report\Figure 3 SPL Area Site Features.mxd 3/20/2014 NAD 1983 StatePlane Washington South FIPS 4602 Feet



DRAFT

Legend

-  Groundwater Monitoring Well Decommissioned June 18, 2013
-  Former Kaiser Building Foundations
-  Site Boundary
-  Approximate SPL Study Area

Note

1. Black and white reproduction of this color original may reduce its effectiveness and lead to incorrect interpretation.

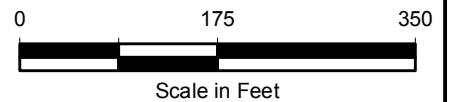

Data Source: Jacobs Engineering; Pierce County Assesor; Google Earth Pro 2010

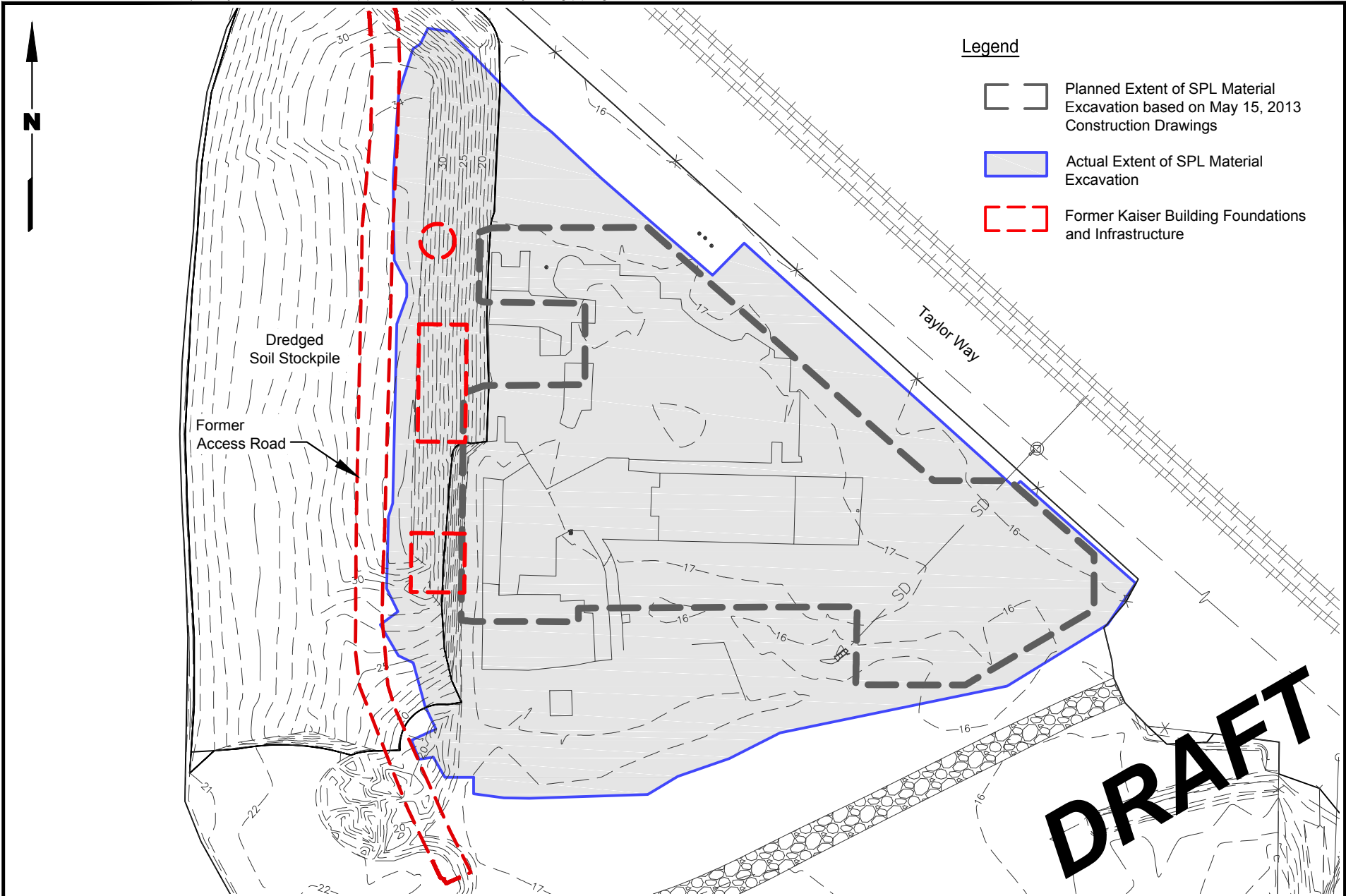

Interim Action
Completion Report
Spent Pot Lining Area
Tacoma, Washington

**Planned vs Actual
SPL Area Excavation Limits**

Figure
4

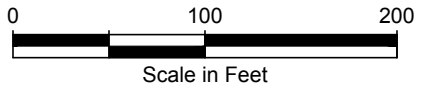
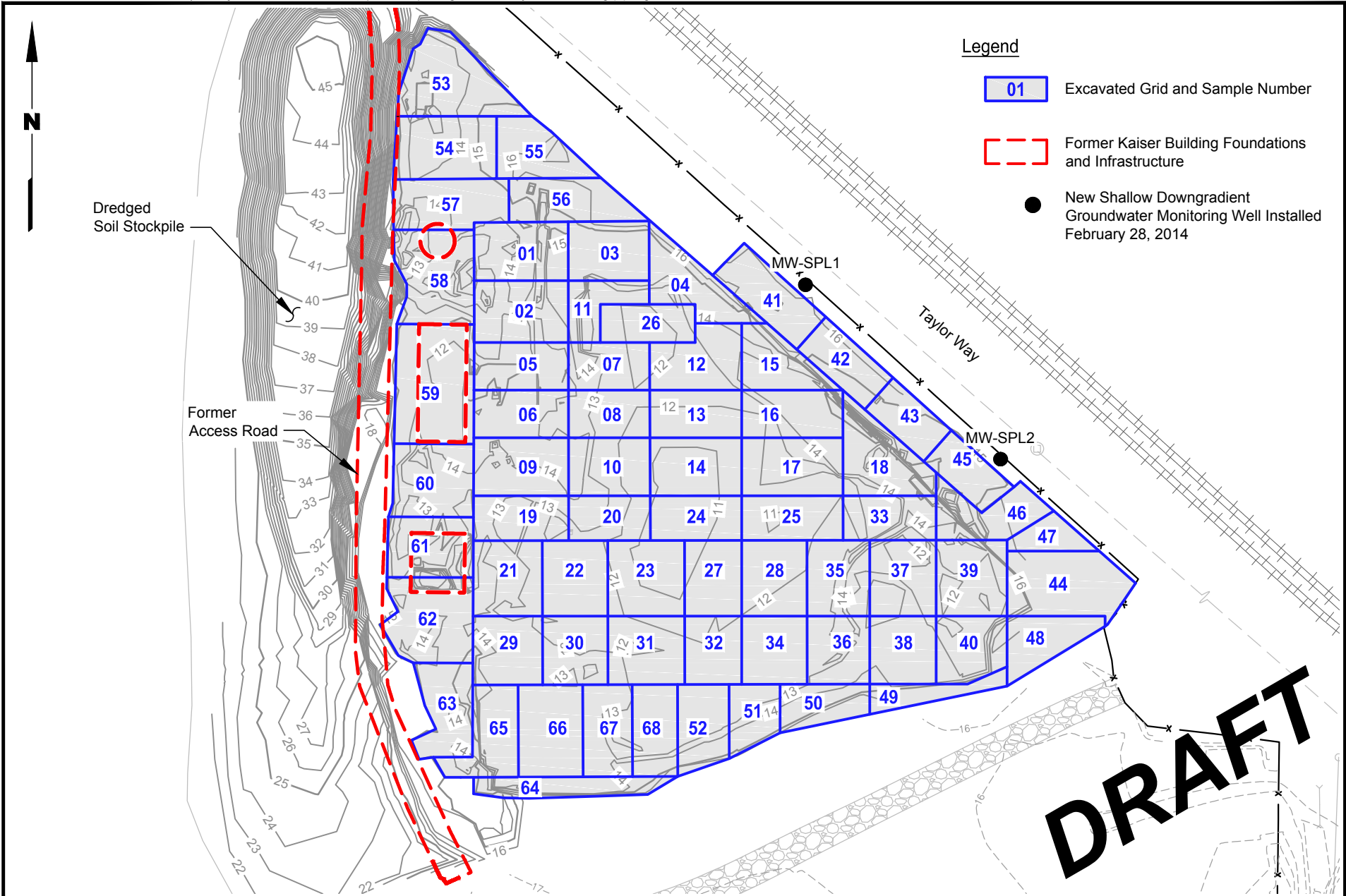

Interim Action
Completion Report
Spent Pot Lining Area
Tacoma, Washington

**Performance Monitoring
Soil Sampling Grid Layout**

Figure
5

TABLE 1
WASTE DISPOSAL SUMMARY
SPENT POT LINING AREA
FORMER KAISER SITE INTERIM ACTION

Date Received at WM Landfill	Number of Trucks	Total Weight (Tons)
8/6/2013	3	95.31
8/7/2013	12	377.78
8/8/2013	11	353.49
8/9/2013	14	458.80
8/12/2013	14	452.80
8/13/2013	14	459.43
8/14/2013	15	461.32
8/15/2013	15	492.64
8/16/2013	14	452.14
8/19/2013	19	605.94
8/20/2013	16	532.33
8/21/2013	18	581.10
8/22/2013	20	641.85
8/23/2013	24	779.62
8/26/2013	23	738.10
8/27/2013	26	836.38
8/28/2013	15	484.61
8/29/2013	19	616.66
8/30/2013	17	558.07
9/3/2013	9	291.21
9/4/2013	20	644.50
9/5/2013	19	621.88
9/6/2013	19	623.30
9/9/2013	23	739.55
9/10/2013	27	871.00
9/11/2013	25	804.97
9/12/2013	10	322.68
9/13/2013	11	354.75
9/16/2013	11	348.62
9/17/2013	17	556.29
9/18/2013	17	536.40
9/19/2013	13	419.57
9/20/2013	15	477.98
9/23/2013	25	807.47
9/24/2013	23	757.04
9/25/2013	27	870.12
9/26/2013	25	805.65
9/27/2013	26	849.08
9/30/2013	17	558.18
10/1/2013	22	712.55
10/2/2013	24	786.63
10/3/2013	24	772.78
10/4/2013	23	749.37
10/7/2013	22	723.55
10/8/2013	20	650.97
10/9/2013	18	584.14
10/10/2013	15	472.37
10/11/2013	19	619.92
10/14/2013	16	514.31
10/15/2013	17	547.29
10/16/2013	16	525.67
10/17/2013	18	585.57
10/18/2013	5	169.89
10/21/2013	15	483.66
10/22/2013	15	483.78
10/23/2013	11	351.63

TABLE 1
WASTE DISPOSAL SUMMARY
SPENT POT LINING AREA
FORMER KAISER SITE INTERIM ACTION

Date Received at WM Landfill	Number of Trucks	Total Weight (Tons)
10/24/2013	10	329.15
10/25/2013	13	420.55
10/28/2013	7	221.58
10/29/2013	14	446.83
10/30/2013	18	582.29
10/31/2013	15	483.53
11/1/2013	16	514.57
11/4/2013	14	451.00
11/5/2013	30	961.63
11/6/2013	25	813.18
11/7/2013	22	709.64
11/11/2013	18	579.04
11/13/2013	3	93.88
11/14/2013	8	258.38
	Total	38,837.94

TABLE 2
POT DUMPING SLAB SUB-SOIL ANALYTICAL DATA
SPENT POT LINING AREA
FORMER KAISER SITE INTERIM ACTION

	MTCA Method C Preliminary Cleanup Level	TPN-1 WZ72A 08/02/2013	TPN-2 WZ72B 08/02/2013	TPE-1 WZ72C 08/02/2013	TPE-2 WZ72D 08/02/2013
CPAHs (µg/kg)					
Method SW8270D					
Benzo(a)anthracene	130	2,500	58 U	7,500	58 U
Chrysene	140	4,300	58 U	10,000	58 U
Benzo[a]pyrene	350	2,000	58 U	8,300	58 U
Indeno(1,2,3-c,d)pyrene	1,200	1,000	58 U	4,200	58 U
Dibenz(a,h)anthracene	640	340	58 U	1,700	58 U
Total Benzofluoranthenes	440	4,000	58 U	9,000	58 U
TEQ	2,000	2,827	NA	10,640	NA
CONVENTIONALS (mg/kg)					
Cyanide	3,200	19.6	4.17	58.1	2.63

Bold = Detected compound.

Box = Exceedance of cleanup level.

NA = Not applicable.

U = Indicates the compound was not detected at the reported concentration.

TABLE 3
SURFICIAL SOIL STOCKPILE ANALYTICAL DATA
SPENT POT LINING AREA
FORMER KAISER SITE INTERIM ACTION

	MTCA Method C Preliminary Cleanup Level	SP1 XB45B 08/13/2013	SP2E XB45A 08/13/2013	SP2W XB45C 08/13/2013
CPAHs (µg/kg)				
Method SW8270D				
Benzo(a)anthracene	130	64 U	290	340
Chrysene	140	64 U	1,400	1,700
Benzo[a]pyrene	350	64 U	220	250
Indeno(1,2,3-c,d)pyrene	1,200	64 U	220	200
Dibenz(a,h)anthracene	640	64 U	97	90
Total Benzofluoranthenes	440	100	1,300	1,400
TEQ	2,000	10	425	470

Bold = Detected compound.

Box = Exceedance of cleanup level.

U = Indicates the compound was not detected at the reported concentration.

TABLE 4
PERFORMANCE MONITORING SOIL ANALYTICAL DATA
SPENT POT LINING AREA
FORMER KAISER SITE INTERIM ACTION

	MTCA Method C Preliminary Cleanup Level	SPL-1 XC60A 08/27/2013	SPL-2 XC60B 08/27/2013	SPL-3 XC78A 8/29/2013	SPL-4 XC78B 8/29/2013	SPL-5 XD32A 9/3/2013	SPL-6 XD32B 9/3/2013	SPL-7 XF64A 9/18/2013	SPL-7 X168A 10/05/2013	SPL-8 XF64B 9/18/2013	SPL-9 XD62A 9/5/2013
CPAHs (µg/kg)											
Method SW8270D											
Benzo(a)anthracene	130	61 U	57 U	61 U	60 U	65 U	61 U	94	64 U	65 U	66 U
Chrysene	140	61 U	57 U	61 U	60 U	73	61 U	180	64 U	65 U	66 U
Benzo[a]pyrene	350	61 U	57 U	61 U	60 U	65 U	61 U	64 U	64 U	65 U	66 U
Indeno(1,2,3-c,d)pyrene	1,200	61 U	57 U	61 U	60 U	65 U	61 U	64 U	64 U	65 U	66 U
Dibenz(a,h)anthracene	640	61 U	57 U	61 U	60 U	65 U	61 U	64 U	64 U	65 U	66 U
Total Benzofluoranthenes	440	61 U	57 U	61 U	60 U	110	61 U	150	64 U	65 U	66 U
TEQ	2,000	NA	NA	NA	NA	12	NA	26	NA	NA	NA

TABLE 4
PERFORMANCE MONITORING SOIL ANALYTICAL DATA
SPENT POT LINING AREA
FORMER KAISER SITE INTERIM ACTION

	MTCA Method C Preliminary Cleanup Level	SPL-10 XD62B 9/5/2013	SPL-11 XG00A 9/20/2013	SPL-12 XG00B 9/20/2013	SPL-13 XD62C 9/5/2013	SPL-14 XD62D 9/5/2013	SPL-14 XG00C 9/20/2013	SPL-14 X163A 10/4/2013	SPL-15 XE56A 9/10/2013	SPL-16 XE56B 9/10/2013	SPL-17 XE88A 9/12/2013
CPAHs (µg/kg)											
Method SW8270D											
Benzo(a)anthracene	130	66 U	61 U	63 U	64 U	430	810	66 U	50 U	52 U	60 U
Chrysene	140	66 U	61 U	63 U	64 U	710	1,400	66 U	50 U	52 U	60 U
Benzo[a]pyrene	350	66 U	61 U	63 U	64 U	400	680	66 U	50 U	52 U	60 U
Indeno(1,2,3-c,d)pyrene	1,200	66 U	61 U	63 U	64 U	340	390	66 U	50 U	52 U	60 U
Dibenz(a,h)anthracene	640	66 U	61 U	63 U	64 U	140	170	66 U	50 U	52 U	60 U
Total Benzofluoranthenes	440	66 U	61 U	69	64 U	1,000	1,600	66 U	50 U	52 U	60 U
TEQ	2,000	NA	NA	6.9	NA	598	991	NA	NA	NA	NA

TABLE 4
PERFORMANCE MONITORING SOIL ANALYTICAL DATA
SPENT POT LINING AREA
FORMER KAISER SITE INTERIM ACTION

	MTCA Method C Preliminary Cleanup Level	SPL-18 XE88B 9/12/2013	SPL-18 XG00C 9/20/2013	SPL-19 XF22A 9/13/2013	SPL-20 XF22B 9/13/2013	SPL-21 XF45F 9/17/2013	SPL-22 XF45G 9/17/2013	SPL-23 XH06A 09/27/2013	SPL-24 XH06B 09/27/2013	SPL-24 X163B 1/4/2013	SPL-25 XH06C 09/27/2013
CPAHs (µg/kg)											
Method SW8270D											
Benzo(a)anthracene	130	88	65 U	66 U	64 U	66 U	61 U	50 U	1,600	62 U	52 U
Chrysene	140	180	65 U	66 U	64 U	66 U	71	67	4,000	62 U	87
Benzo[a]pyrene	350	60 U	65 U	66 U	64 U	66 U	61 U	50 U	1,100	62 U	52 U
Indeno(1,2,3-c,d)pyrene	1,200	60 U	65 U	66 U	64 U	66 U	61 U	50 U	680	62 U	52 U
Dibenz(a,h)anthracene	640	60 U	65 U	66 U	64 U	66 U	61 U	50 U	220	62 U	52 U
Total Benzofluoranthenes	440	120	65 U	66 U	64 U	66 U	74	59	3,000	62 U	65
TEQ	2,000	23	NA	NA	NA	NA	8.1	6.6	1,690	NA	7.37

TABLE 4
PERFORMANCE MONITORING SOIL ANALYTICAL DATA
SPENT POT LINING AREA
FORMER KAISER SITE INTERIM ACTION

	MTCA Method C Preliminary Cleanup Level	SPL-26 X168B 10/05/2013	SPL-27 XJ15A 10/09/2013	SPL-28 XJ15B 10/09/2013	SPL-29 XJ41A 10/10/2013	SPL-29 XK11C 10/23/2013	SPL-30 XJ41B 10/10/2013	SPL-30 XK11B 10/23/2013	SPL-31 XJ41C 10/10/2013	SPL-32 XJ41D 10/10/2013	SPL-33 XJ41E 10/10/2013
CPAHs (µg/kg)											
Method SW8270D											
Benzo(a)anthracene	130	66 U	75 U	80 U	66 U	61 U	960	60 U	64 U	66 U	59 U
Chrysene	140	66 U	75 U	80 U	220	61 U	1,400	60 U	64 U	66 U	59 U
Benzo[a]pyrene	350	66 U	75 U	80 U	66 U	61 U	1,100	60 U	64 U	66 U	59 U
Indeno(1,2,3-c,d)pyrene	1,200	66 U	75 U	80 U	66 U	61 U	730	60 U	64 U	66 U	59 U
Dibenz(a,h)anthracene	640	66 U	75 U	80 U	66 U	61 U	260	60 U	64 U	66 U	59 U
Total Benzofluoranthenes	440	66 U	75 U	80 U	250	61 U	1,600	60 U	64 U	66 U	59 U
TEQ	2,000	NA	NA	NA	27	NA	1,469	NA	NA	NA	NA

TABLE 4
PERFORMANCE MONITORING SOIL ANALYTICAL DATA
SPENT POT LINING AREA
FORMER KAISER SITE INTERIM ACTION

	MTCA Method C Preliminary Cleanup Level	SPL-34 XK04A 10/16/2013	SPL-35 XJ86A 10/15/2013	SPL-36 XK04B 10/16/2013	SPL-37 XL63A 10/29/2013	SPL-38 XL49C 10/28/2013	SPL-39 XK75A 10/21/2013	SPL-40 XK75B 10/21/2013	SPL-41 XK75C 10/21/2013	SPL-42 XK75D 10/21/2013	SPL-43 XK11A 10/23/2013
CPAHs (µg/kg)											
Method SW8270D											
Benzo(a)anthracene	130	63 U	63 U	62 U	65 U	42 U	61 U	64 U	66 U	64 U	61 U
Chrysene	140	63 U	63 U	62 U	65 U	42 U	61 U	64 U	66 U	64 U	61 U
Benzo[a]pyrene	350	63 U	63 U	62 U	65 U	42 U	61 U	64 U	66 U	64 U	61 U
Indeno(1,2,3-c,d)pyrene	1,200	63 U	63 U	62 U	65 U	42 U	61 U	64 U	66 U	64 U	61 U
Dibenz(a,h)anthracene	640	63 U	63 U	62 U	65 U	42 U	61 U	64 U	66 U	64 U	61 U
Total Benzofluoranthenes	440	63 U	63 U	62 U	65 U	42 U	61 U	64 U	66 U	64 U	61 U
TEQ	2,000	NA	NA	NA	NA	NA	NA	NA	NA	NA	NA

TABLE 4
PERFORMANCE MONITORING SOIL ANALYTICAL DATA
SPENT POT LINING AREA
FORMER KAISER SITE INTERIM ACTION

	MTCA Method C Preliminary Cleanup Level	SPL-44 XL49A 10/28/2013	SPL-45 XL39 10/25/2013	SPL-46 XL39B 10/25/2013	SPL-47 XL39C 10/25/2013	SPL-48 XL49B 10/28/2013	SPL-49 XL63B 10/29/2013	SPL-50 XL63C 10/29/2013	SPL-51 XL63D 10/29/2013	SPL-52 XL63E 10/29/2013	SPL-53 XN53A 11/11/2013
CPAHs (µg/kg)											
Method SW8270D											
Benzo(a)anthracene	130	44 U	44 U	46 U	47 U	47	66 U	63 U	60 U	66 U	1800
Chrysene	140	44 U	44 U	46 U	47 U	76	66 U	63 U	120	66 U	2300
Benzo[a]pyrene	350	44 U	44 U	46 U	47 U	51	66 U	63 U	66	66 U	2200
Indeno(1,2,3-c,d)pyrene	1,200	44 U	44 U	46 U	47 U	73	66 U	63 U	67	66 U	1400 J
Dibenz(a,h)anthracene	640	44 U	44 U	46 U	47 U	46 U	66 U	63 U	60 U	66 U	690 J
Total Benzofluoranthenes	440	44 U	44 U	46 U	47 U	98	66 U	63 U	250	66 U	3200
TEQ	2,000	NA	NA	NA	NA	74	NA	NA	99	NA	2932

TABLE 4
PERFORMANCE MONITORING SOIL ANALYTICAL DATA
SPENT POT LINING AREA
FORMER KAISER SITE INTERIM ACTION

	MTCA Method C Preliminary Cleanup Level	SPL-53 XN77A 11/13/2013	SPL-54 XN53B 11/11/2013	SPL-54 XN77B 11/13/2013	SPL-55 XN53C 11/11/2013	SPL-56 XM90A 11/6/2013	SPL-57 XM90B 11/6/2013	SPL-58 XM90C 11/6/2013	SPL-59 XM90D 11/6/2013	SPL-60 XM90E 11/6/2013	SPL-61 XM90F 11/6/2013
CPAHs (µg/kg)											
Method SW8270D											
Benzo(a)anthracene	130	63 U	1800	60 U	60 U	60 U	63 U	61 U	60 U	64 U	59 U
Chrysene	140	63 U	2300	60 U	60 U	60 U	63 U	90	74	64 U	59 U
Benzo[a]pyrene	350	63 U	2200	60 U	60 U	60 U	63 U	61	60 U	64 U	59 U
Indeno(1,2,3-c,d)pyrene	1,200	63 U	1400 J	60 U	60 U	60 U	63 U	61 U	60 U	64 U	59 U
Dibenz(a,h)anthracene	640	63 U	720 J	60 U	60 U	60 U	63 U	61 U	60 U	64 U	59 U
Total Benzofluoranthenes	440	63 U	3200	60 U	60 U	60 U	63 U	120	110	64 U	59 U
TEQ	2,000	NA	2935	NA	NA	NA	NA	74	12	NA	NA

TABLE 4
PERFORMANCE MONITORING SOIL ANALYTICAL DATA
SPENT POT LINING AREA
FORMER KAISER SITE INTERIM ACTION

	MTCA Method C Preliminary Cleanup Level	SPL-62 XM90G 11/6/2013	SPL-62 XN66A 11/12/2013	SPL-63 XN53D 11/11/2013	SPL-64 XO06A 11/14/2013	SPL-65 XN53E 11/11/2013	SPL-66 XN53F 11/11/2013	SPL-67 XN53G 11/11/2013	SPL-68 XN53H 11/11/2013	SPL-68 XN77C 11/13/2013
CPAHs (µg/kg)										
Method SW8270D										
Benzo(a)anthracene	130	140	55 U	68 U	59 U	63 U	62 U	60 U	510	63 U
Chrysene	140	840	55 U	68 U	59 U	63 U	62 U	60 U	630	63 U
Benzo[a]pyrene	350	130	55 U	68 U	59 U	63 U	62 U	60 U	510	63 U
Indeno(1,2,3-c,d)pyrene	1,200	190	55 U	68 U	59 U	63 U	62 U	60 U	290 J	63 U
Dibenz(a,h)anthracene	640	76	55 U	68 U	59 U	63 U	62 U	60 U	130 J	63 U
Total Benzofluoranthenes	440	590	55 U	68 U	59 U	63 U	62 U	60 U	980	63 U
TEQ	2,000	238	NA	NA	NA	NA	NA	NA	707	NA

Bold = Detected compound.

Box = Exceedance of cleanup level.

NA = Not applicable.

J = Indicates the analyte was positively identified; the associated numerical value is the approximate concentration of the analyte in the sample.

U = Indicates the compound was not detected at the reported concentration.

UJ = The analyte was not detected in the sample; the reported sample reporting limit is an estimate.

Selected Site Photographs



1. Looking northeast across the SPL Area prior to removal of surficial concrete slabs and asphalt pavement.



2. Looking northwest across the steel rails embedded in the surface of the pot dumping slab in the former SPL management facility.

3/20/14 P:\118033\WP\RSPL Area Completion Report\AppA_Photos\A-1.docx



3. Looking southeast across the SPL Area during demolition of surficial concrete slabs and asphalt pavement.



4. Stockpiled concrete and asphalt demolition debris prior to rubblization.

3/20/14 P:\118033\WIP\R\SPL Area Completion Report\AppA_Photos\A-2.docx



5. Looking southwest toward the automated wheel wash facility located adjacent to the site access road.



6. SPL zone material (dark gray) and underlying uncontaminated soil.

3/20/14 P:\118033\WIP\R\SPL Area Completion Report\AppA_Photos\A-3.docx



7. Looking east across the pot dumping slab in the former SPL management facility.



8. Close-up view of heavy rebar and steel rail reinforcement in the pot dumping slab.

3/20/14 P:\118033\WP\RSPL Area Completion Report\AppA_Photos\A-4.docx



9. Close-up view of SPL material used as utility trench backfill.



10. Looking southeast across the SPL Area excavation, with view of pot dumping slab, SPL material in utility trenches, and temporary stockpile of excavated SPL material to be loaded for disposal.

3/20/14 P:\118033\WPIR\SPL Area Completion Report\AppA_Photos\A-5.docx



11. Looking southeast across the southern portion of the SPL Area during removal of SPL material.



12. Looking southwest at a layer of SPL material extending under the dredged soil stockpile.

3/20/14 P:\118033\WIP\R\SPL Area Completion Report\AppA_Photos\A-6.docx



13. Looking south along the west side of the foundations of former buildings exposed during SPL material removal under the dredged soil stockpile.



14. Looking west across the SPL Area excavation toward the dredged soil stockpile. Note water ponding in the deeper excavation areas.

3/20/14 P:\118033\WP\RSPL Area Completion Report\AppA_Photos\A-7.docx



15. Looking southeast across the completed SPL Area excavation from the dredged soil stockpile, with water ponded in a significant portion of the excavation.



16. Looking southwest at the stormwater diversion berm constructed along the south side of the SPL Area excavation where water is ponded.

3/20/14 P:\118033\W\PIRSPL Area Completion Report\AppA_Photos\A-8.docx



17. Looking southeast across the completed SPL Area excavation from the northern end of the dredged soil stockpile.



18. Looking northwest across the completed SPL Area excavation toward the dredged soil stockpile, with water ponded in a significant portion of the excavation.

3/20/14 P:\118033\WP\RSPL Area Completion Report\AppA_Photos\A-8.docx

Permits/Approvals and SEPA Documentation



STATE OF WASHINGTON
DEPARTMENT OF ECOLOGY

PO Box 47600 • Olympia, WA 98504-7600 • 360-407-6000

711 for Washington Relay Service • Persons with a speech disability can call 877-833-6341

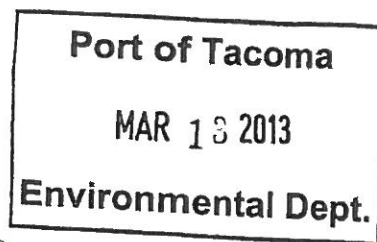

March 7, 2013

William Evans
Environmental Project Manager
Port of Tacoma
PO Box 1837
Tacoma, WA 98401-1847

RE: CAMU-eligible soils at the Port of Tacoma Kaiser Site, Facility Site ID #38

Dear Mr. Evans:

This letter is to document the Department of Ecology's (Ecology's) determination that soils from the Port of Tacoma Kaiser Site Spent Pot Lining (SPL) Area contaminated with K088 listed waste and other constituents of concern are Corrective Action Management Unit (CAMU)-eligible waste under the Dangerous Waste Regulations (Chapter 173-303 WAC). These soils may be disposed off-site at a designated hazardous waste landfill according to WAC 173-303-646920.

At a meeting held June 15, 2012, and in an email dated June 18, 2012, Kris Hendrickson of Landau Associates, the Port of Tacoma's consultant, presented adequate information for Ecology to tentatively approve placement of soils from the Port of Tacoma Kaiser Site SPL Area in an off-site dangerous waste landfill as CAMU-eligible waste.

The Dangerous Waste Regulations require Ecology to determine "principal hazardous constituents" (PHCs) in the soils and proposed treatment levels for each PHC. For the Port of Tacoma Kaiser Site these are found in Appendix B (CAMU-Eligible Waste Treatment Levels) in *Final SPL Interim Action Work Plan, Former Kaiser Aluminum Property, 3400 Taylor Way, Tacoma, Washington*, dated February 28, 2013.

The Dangerous Waste Regulations require Ecology to provide public notice and a reasonable opportunity for public comment before approving placement of CAMU-eligible waste in an off-site landfill. The recent public comment period (January 24 to February 25, 2013) on the interim action work plan included information and a request to comment about the off-site disposal of site soils as CAMU-eligible waste. No comments were received specific to the CAMU-eligible waste proposal.

The federal regulations (40 CFR 264.555) outline the remaining requirements for approving placement of CAMU-eligible waste in an off-site landfill. Part 264.555(e) outlines the necessary procedures for public comment and regulatory approval at the landfill before CAMU-eligible waste may be placed in the off-

William Evans
March 7, 2013
Page 2

site landfill. Ecology understands that soils from the Port of Tacoma Kaiser Site will be sent to the Chemical Waste Management (CWM) Subtitle C Facility in Arlington, Oregon, and that this facility is permitted to accept CAMU-eligible waste. For each cleanup generating a CAMU-eligible waste, CWM must request an additional permit modification from the Oregon Department of Environmental Quality (DEQ), including the source of the CAMU waste, its PHCs, and the applicable treatment requirements. Public notice by CWM is also required (40 CFR § 264.555(d)-(e)). The DEQ may object to the off-site placement of CAMU-eligible waste within 30 days of CWM's notification (40 CFR §264.555(e)(3)). CAMU-eligible wastes may not be placed in the landfill until DEQ has notified CWM that DEQ does not object to its placement.

WAC 173-303-646910(6) requires generators of CAMU-eligible wastes sent to an off-site dangerous waste landfill to comply with the reporting, tracking, and recordkeeping requirements of 40 CFR 268.7(a)(4).

If you have questions about this letter, please contact me at 360-407-6359.



Kaia Petersen
Licensed Hydrogeologist
Department of Ecology
Hazardous Waste and Toxics Reduction
Southwest Regional Office
kaia.petersen@ecy.wa.gov

cc: Marv Coleman, Department of Ecology, marv.coleman@ecy.wa.gov
Kristy Hendrickson, Landau Associates, khendrickson@landauinc.com
Rich Duval, Oregon Department of Environmental Quality, duval.rich@deq.state.or.us



STATE OF WASHINGTON
DEPARTMENT OF ECOLOGY

PO Box 47600 • Olympia, WA 98504-7600 • 360-407-6000

711 for Washington Relay Service • Persons with a speech disability can call 877-833-6341

July 19, 2013

Jennifer Stebbings
Port of Tacoma
PO Box 1837
Tacoma, WA 98401-1837

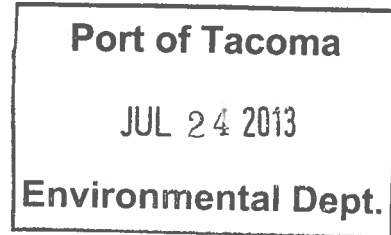

RE: Coverage under the Construction Stormwater General Permit

Permit number: WAR127225
Site Name: Kaiser Site Interim Action Cleanup
Location: 3400 Taylor Way
Tacoma, WA County: Pierce
Disturbed Acres: 19.3

Dear Ms. Stebbings:

The Washington State Department of Ecology (Ecology) received your Notice of Intent for coverage under Ecology's Construction Stormwater General Permit (permit). This is your permit coverage letter. Your permit coverage is effective on July 19, 2013. **Please retain this permit coverage letter with your permit (enclosed), stormwater pollution prevention plan (SWPPP), and site log book. These materials are the official record of permit coverage for your site.**

Please take time to read the entire permit and contact Ecology if you have any questions.

Appeal Process

You have a right to appeal coverage under the general permit to the Pollution Control Hearing Board (PCHB) within 30 days of the date of receipt of this letter. This appeal is limited to the general permit's applicability or non-applicability to a specific discharger. The appeal process is governed by chapter 43.21B RCW and chapter 371-08 WAC. "Date of receipt" is defined in RCW 43.21B.001(2).



Jennifer Stebbings
July 19, 2013
Page 2

To appeal, you must do the following within 30 days of the date of receipt of this letter:

- File your appeal and a copy of the permit cover page with the PCHB (see addresses below). Filing means actual receipt by the PCHB during regular business hours.
- Serve a copy of your appeal and the permit cover page on Ecology in paper form - by mail or in person (see addresses below). E-mail is not accepted.

You must also comply with other applicable requirements in chapter 43.21B RCW and chapter 371-08 WAC.

Address and Location Information:

Street Addresses:

Department of Ecology
Attn: Appeals Processing Desk
300 Desmond Drive SE
Lacey, WA 98503

Mailing Addresses:

Department of Ecology
Attn: Appeals Processing Desk
PO Box 47608
Olympia, WA 98504-7608

Pollution Control Hearings Board (PCHB)
1111 Israel Road SW, Suite 301
Tumwater, WA 98501

Pollution Control Hearings Board
PO Box 40903
Olympia, WA 98504-0903

Electronic Discharge Monitoring Reports (WQWebDMR)

This permit requires that Permittees submit monthly discharge monitoring reports (DMRs) electronically using Ecology's secure online system, WQWebDMR. To sign up for WQWebDMR go to: www.ecy.wa.gov/programs/wq/permits/paris/webdmr.html. If you have questions, contact Tonya Wolfe at (360) 407-7097 (Olympia area), or (800) 633-6193/option 3, or email WQWebPortal@ecy.wa.gov.

Ecology Field Inspector Assistance

If you have questions regarding stormwater management at your construction site, please contact Sam Knox of Ecology's Southwest Regional Office in Lacey at sam.knox@ecy.wa.gov, or (360) 407-6294.

Questions or Additional Information

Ecology is committed to providing assistance. Please review our web page at: www.ecy.wa.gov/programs/wq/stormwater/construction/. If you have questions about the construction stormwater general permit, please contact Josh Klimek at josh.klimek@ecy.wa.gov, or (360) 407-7451.

Sincerely,



Bill Moore, P.E., Manager
Program Development Services Section
Water Quality Program

Enclosure



Oregon

John A. Kitzhaber, MD, Governor

Department of Environmental Quality

Eastern Region-The Dalles Office

400 East Scenic Drive, Suite 307

The Dalles, OR 97058

(541) 298-7255

FAX (541) 298-7330

April 22, 2013

Mr. Jim Denson
Oregon Environmental Protection Manager
Chemical Waste Management of the Northwest, Inc.
17629 Cedar Springs Lane
Arlington, OR 97812

Re: CAMU waste approval
Port of Tacoma
Arlington Facility
ORD 089 452 353

Dear Mr. Denson:

The Department received a request dated April 18, 2013, to receive corrective action management unit (CAMU) eligible waste for disposal. The waste is cleanup soil which will be removed from the former Kaiser Aluminum Property in Tacoma, Washington. This waste was determined to be eligible for offsite disposal, under the CAMU rules, by the Washington Department of Ecology and will not require treatment prior to disposal.

A public comment period for this request was held for 15 days, which ended on April 17, 2013. No comments were received.

Therefore, based on the Department's review and no comments being received from the public, the request to receive the CAMU eligible waste at your Arlington hazardous waste facility is approved.

If you have any questions concerning this approval, please contact Rich Duval of my staff at (541) 278-4613.

Sincerely,

Elizabeth Druback
Eastern Region Manager
Hazardous and Solid Waste Program

cf: Rich Duval, DEQ Pendleton

PORT OF TACOMA

ENVIRONMENTAL CHECKLIST

FORMER KAISER ALUMINUM FACILITY, REMEDIAL ACTIONS UNDER AGREED ORDER DE-5698

A. **Background**

1. **Name of proposed project, if applicable:** Former Kaiser Aluminum Facility, Interim Actions under Agreed Order DE-5698

2. **Name of applicant:** Port of Tacoma

3. **Address and phone number of applicant and contact person:**

Port of Tacoma
ATTN: Bill Evans
PO Box 1837
Tacoma, WA 98401-1837
253-593-4563

4. **Date checklist prepared:**

12/27/2012

5. **Agency requesting checklist:**

Port of Tacoma

6. **Proposed timing or schedule (including phasing, if applicable):**

The current project is expected to begin in about May 2013 and should be completed by October 2013.

7. **Do you have any plans for future actions, expansions, or further activity related to or connected with this proposal? If yes, explain.**

The Port of Tacoma's long-term plan is to redevelop the entire 96 acre property for port maritime industrial uses. Specific future uses are unknown at this time and will be addressed separately via SEPA and other permitting actions as the Port develops plans to meet future tenant requirements.

8. **List any environmental information you know about that has been prepared, or will be prepared, directly related to this proposal.**

Existing environmental information, reports, and documents related to the site are listed in the subject Agreed Order. Additional information is contained in a "Compilation Report" for the site dated November 30, 2011 and "Final Remedial Investigation/Feasibility Study"

dated August 23, 2012. Both of these reports are available from Ecology or the Port of Tacoma.

This project is anticipated to prepare the following environmental information/reports for two of the six areas of interest at the property (listed below in 11a through 11f). A figure showing all six areas of interest described in the Agreed Order, including the two areas slated for interim actions as described herein, is attached to this Checklist as Exhibit A.

- Interim Action Work Plan(s) and Interim Action(s), including supporting documentation.

The Interim Action areas are currently operating under regulatory oversight, as described in the following legal instruments.

- Spent Potliner Management Area, EPA/Ecology ID No. WAD 001882984
- Former Kaiser Site Remedial Action, Ecology Agreed Order No. DE-5698

9. Do you know whether applications are pending for governmental approvals of other proposals affecting the property covered by your proposal? If yes, explain.

The Port is designing and will soon permit a stormwater bio-treatment facility on a small portion of the site that will treat stormwater from the log handling facility at 3401 Taylor Way. The planned bio-treatment facility is not within or near either of the two interim action construction areas.

10. List any government approvals or permits that will be needed for your proposal, if known.

The Port anticipates that one or more of the following will be required: Ecology NPDES and State Waste Discharge General Permit for Stormwater Discharges Associated with Construction Activity; Tacoma-Pierce County Health Department (TPCHD) Waste Disposal Authorization, and as necessary, City of Tacoma Grading Permit.

11. Give brief, complete description of your proposal, including the proposed use and the size of the project and site. There are several questions later in this checklist that ask you to describe certain aspects of your proposal. You do not need to repeat those answers on this page. (Lead agencies may modify this form to include specific information on project description).

Rod Mill Closed Landfill: The interim action excavation activities will be conducted within the footprint of the waste material, which covers approximately 0.9 acres. The waste material forms an irregular shape within the Closed Landfill footprint. Because the waste material is found relatively close to the surface in the Closed Landfill, it is assumed for conceptual design purposes that soil above the waste material will be excavated and will likely be disposed off site along with the underlying waste material. However, if there are areas identified where relatively thick zones of clean overlying soil can be feasibly

identified and separated from the underlying waste material, such overlying soil may be excavated and stockpiled for reuse as excavation backfill material.

The estimated excavation volume for the Closed Landfill, including the soil above and a 1-ft-thick zone of soil beneath the waste material, is approximately 12,300 cubic yards (yd³). The estimated volume of waste material to be excavated was calculated by taking an average surface area from the lengths of waste in Profiles A-A' and B-B' (39,000 ft²) and multiplying by the total depth of the waste material plus the 1-ft-thick zone of underlying soil (8.5 ft).

The interim action will consist of the following elements:

- Decommissioning of groundwater monitoring wells in or near the Closed Landfill
- Excavation of waste material and associated contaminated soil from the ground surface to approximately 1 ft below the bottom of the waste material
- Localized excavation of deeper soil in the vicinity of MW-6 where contaminants were detected at concentrations greater than the cleanup levels in the underlying fill and native soil materials
- Handling, size reduction (as needed), and disposal of excavated waste material and soil
- Handling and disposal of construction water (if any)
- Surveying of the final excavation extent and depth
- Backfilling the excavation area to final grade with clean, compacted fill, sloping the surface as needed to promote drainage of stormwater
- Final site grading and restoration
- Post-excavation groundwater monitoring.

Spent Potliner Area (SPL): In order to estimate the areas and volumes of SPL zone material and associated contaminated soil that exceed cleanup levels and require remedial action, the SPL Area was divided into three subareas (A, B, and C) based on different average thicknesses of SPL zone material found in those areas. Area A is approximately 55,800 ft² and has an average SPL zone thickness of 1.5 ft. Area B is approximately 22,300 ft² and has an average SPL zone thickness of 2.6 ft. Area C is approximately 7,600 ft² and has an average SPL zone thickness of 0.5 ft. The combined volume of SPL zone material in subareas A, B, and C, excluding soil directly above and below the SPL zone material, is approximately 5,390 cubic yards (yd³).

Because the SPL zone material is typically found relatively close to the ground surface, it is assumed for design purposes that the volume of material excavated would need to include the overlying soil and up to an additional 0.5 ft of soil underlying the SPL zone material. Thus, the estimated total volume of SPL zone material and associated contaminated soil

that might need to be excavated for disposal is currently estimated to be 9,400 yd³. However, if there are areas identified where relatively thick zones of clean overlying soil can be feasibly identified and separated from the SPL zone material, such overlying soil may be excavated and stockpiled for reuse as excavation backfill material.

There are localized areas of soil contamination located more than 0.5 ft beneath the SPL zone material. The extent of such underlying contaminated soil appears to be limited to three locations, and it is currently assumed that up to about 30 yd³ of additional contaminated soil might potentially need to be excavated in addition to the estimated 9,400 yd³ of material noted above.

Based on the available data, it is not anticipated that excavations in the SPL area will typically extend below the groundwater table. Additionally, interim action construction activities are planned to be conducted during late summer/early fall when the groundwater level is at or near its seasonal low. Therefore, handling of wet, excavated material and construction water are not anticipated to be a significant component of interim action construction activities.

Additional supporting information for both interim action areas, such as figures showing the locations of subareas and cross sections, can be found in the Compilation and RI/FS reports.

12. **Location of the proposal. Give sufficient information to understand the precise location of your proposed project, including a street address, if any, and section, township, and range, if known. If a proposal would occur over a range of area, provide the range or boundaries of the site(s). Provide a legal description, site plan, vicinity map, and topographic map, if reasonably available. While you should submit any plans required by the agency, you are not required to duplicate maps and detailed plans submitted with any specific applications related to this checklist.**

The Project site is located on property formerly owned by Kaiser Aluminum at 3400 Taylor Way, Tacoma, WA, 98421. The Project site is located within Section 36, Township 21 North, Range 3 East of the Willamette Meridian, County of Pierce, State of Washington.

B. Environmental Elements

1. Earth

- a. **General description of the site (underline one): Flat, rolling, hilly, mountainous, other.**

Flat.

- b. **What is the steepest slope on the site (approximate percent slope)?**

The site is generally flat with less than a 1% slope. Perimeter areas where fill has been placed typically have 2:1 to 3:1 (H to V) side slopes, up to about 5ft high.

- c. **What general types of soils are found on the site (for example, clay, sand, gravel, peat, muck)? If you know the classification of agricultural soils, specify them and note any prime farmland.**

Generally, the site was raised to existing grades by filling, using predominantly silt, sand and gravel. The underlying native soil consists of interbedded silt, sand, and peat. There is no prime farmland on the property or in the immediate vicinity.

- d. **Are there surface indications or history of unstable soils in the immediate vicinity? If so, describe.**

None known.

- e. **Describe the purpose, type, and approximate quantities of any filling or grading proposed. Indicate source of fill.**

Removing contaminated materials is straight forward and involves excavating and disposing of waste material and geotechnically unsuitable soil at an approved landfill. This is the preferred approach at both remediation areas. Cleanup actions involving excavation are expected to generate less than 25,000 cubic yards of soil and waste, with approximately the same volume of soil used as "clean" backfill. If weather condition allow, existing stockpiled soil and crushed concrete/asphalt materials will be used as backfill, otherwise fill material will be imported from a suitable source.

Capping the contaminated materials onsite would involve installation of an impervious cover, and while not the preferred remedy, would be implemented if required by unanticipated site conditions and after approval by Ecology. Typical environmental caps are constructed out of concrete, asphalt, geosynthetics, or a combination thereof. At this site, the use of geosynthetics with a soil cover would be the most likely choice. The cap(s) could be placed over existing contaminated materials that remain in place or the contaminated materials could be consolidated into a smaller footprint and capped. Earthwork necessary for environmental cap construction would be substantially less than cited above for the removal and backfilling options.

Any stockpiles of soil or wastes will be protected from erosion by using BMP's.

- f. **Could erosion occur as a result of grading, filling, construction, or use? If so, generally describe.**

Protective measures will be in place to control erosion during the life of the Project. A Stormwater Pollution Prevention Plan (SWPPP) will be prepared in accordance with the Port's *NPDES and State Waste Discharge General Permit for Stormwater Discharges Associated with Construction Activity* prior to waste removal, site grading and stockpiling activities, and will describe actions to reduce and control the potential for erosion.

- g. **About what percent of the site will be covered with impervious surfaces after project completion (for example, asphalt or buildings)?**

No impervious pavements or buildings will be added during this project. In the SPL Area, several concrete and asphalt surfaces will be removed thereby decreasing the amount of impervious surfaces. If capping of site contaminants increases the amount of impervious

surfacing, engineered systems will be designed and installed to prevent uncontrolled runoff from those areas consistent with Ecology's Surface Water Management Manual.

h. Proposed measures to reduce or control erosion, or other impacts to the earth, if any:

Control measures (e.g. silt fences, mulching, etc.) will be used as appropriate to minimize erosion during project implementation. Best management practices (BMPs) for the temporary construction activities will meet Ecology's stormwater management manual.

2. Air

a. What type of emissions to the air would result from the proposal (i.e. dust, automobile, odors, industrial, wood smoke) during construction and when the project is completed? If any, generally describe and give approximate quantities, if known.

During the project, there will be an increase in air emissions associated with remedial action construction equipment. The Port requires the use of ultra low sulfur diesel in construction equipment on its projects and has an enforced anti-idling policy. Based on previous experience with this type of work on other projects, it is expected that the PM_{2.5} emissions from this project, as compared to the General Conformity de minimis levels for PM_{2.5} (100 tons per year), are insignificant and will not affect regional air quality.

There is also the possibility of fugitive dust (which will be controlled through BMPs) associated with the construction activity. These potential emissions are compatible with the surrounding heavy industrial land uses.

b. Are there any off-site sources of emissions or odor that may affect your proposal? If so, generally describe.

No sources which could affect this project have been identified.

c. Proposed measures to reduce or control emissions or other impacts to air, if any:

The Port requires the use of ultra-low sulfur diesel in construction equipment and has an enforced anti-idling policy for both operational and construction equipment. Fugitive dust will be controlled through the use of BMPs.

3. Water

a. Surface:

1) Is there any surface water body on or in the immediate vicinity of the site (including year-round and seasonal streams, saltwater, lakes, ponds, wetlands)? If yes, describe type and provide names. If appropriate, state what stream or river it flows into.

The Project site is located on the "East Blair peninsula" which is located between the Hylebos and Blair waterways of Commencement Bay. The site does not abut either of these waterways. Two industrial process water /stormwater detention ponds constructed by Kaiser Aluminum are located on the former Kaiser property, but outside of areas identified

for interim actions. Stormwater from most of the Project site will continue to be directed into these ponds. There are no jurisdictional wetlands on the site, although there are ditches and one pond along the margins of the property which may contain jurisdiction features. The City of Tacoma's govME geographic information system (GIS) identifies a wetland (high probability) and a critical area (habitat zone) on the adjacent Bonneville Power Administration (BPA) property to the south-southwest of the site. In addition, a small wetland/critical area is located on an adjacent parcel owned by the Port (near the southwest corner of the site) but outside of any potential work area. The City of Tacoma has determined that the buffer for the offsite wetland is interrupted and is not anywhere near the two work areas.

- 2) **Will the project require any work over, in, or adjacent to (within 200') the described waters? If yes, please describe and attach available plans.**

Yes, some work will be implemented near the ditch which is located east of the Rod Mill Landfill area. No work is planned within the ditch itself, and no permits are required.

- 3) **Estimate the amount of fill and dredge material that would be placed in or removed from surface water or wetlands and indicate the area of the site that would be affected. Indicate the source of fill material.**

None.

- 4) **Will the proposal require surface water withdrawals or diversions? Give general description, purpose, and approximate quantities, if known.**

No.

- 5) **Does the proposal lie within a 100-year floodplain? If so, note the location on the site plan.**

No. [Note: FEMA identifies some old Kaiser process water settling ponds (no longer in existence) as being within the floodplain. This is an incorrect representation of these constructed industrial facilities.]

- 6) **Does the proposal involve any discharges of waste materials to surface waters? If so, describe the type of waste and anticipated volume of discharge.**

No waste materials will be discharged to surface waters.

b. Ground:

- 1) **Will groundwater be withdrawn, or will water be discharged to groundwater? Give general description, purpose, and approximate quantities if known.**

Possibly. In the event oil is found floating on groundwater within the Rod Mill Closed Landfill waste excavation footprint, it is likely that several tanker loads of oily water would be pumped out to remove source material and address groundwater contamination

concerns. Removed water would be tested and disposed of properly. For planning purposes, the estimated quantity of water that could be removed from the excavation is 10,000 to 30,000 gallons.

- 2) **Describe waste materials that will be discharged into the ground from septic tanks or other sources, if any (for example: Domestic sewage; industrial, containing the following chemicals...; agricultural; etc.) Describe the general size of the system, the number of such systems, the number of houses to be served (if applicable), or the number of animals or humans the system(s) are expected to serve.**

None.

c. **Water Runoff (including storm water):**

- 1) **Describe the source of runoff (including storm water) and the method of collection and disposal, if any (include quantities, if known). Where will this water flow? Will this water flow into other waters? If so, describe.**

The site has previously been graded to allow some stormwater to infiltrate into the ground, some to flow into two existing stormwater ponds located on the property, part to flow into the municipal drainage systems along Taylor Way and Alexander Avenue, and some to flow toward the SR 590/Taylor Way intersection via a series of ditches. Surface water runoff within the Spent Pot Liner area flows to an existing inlet structure, then to the municipal system along Taylor Way and eventually into the Hylebos Waterway via the Kaiser Ditch. Rainfall within the Rod Mill Landfill area infiltrates into the sandy soil (hydraulic fill placed in the mid 1960's) present within this portion of the site.

- 2) **Could waste materials enter ground or surface waters? If so, generally describe.**

For the proposed interim actions, wastes will be properly characterized, handled and disposed of in an approved manner. This will eliminate a potential source of contamination to ground and surface waters. Materials from accidental spills associated with construction activities could potentially occur. The Port will prepare a Stormwater Pollution Prevention Plan (SWPPP) for the project area and work. In addition, the Port will require the contractors to develop a spill prevention, control and countermeasure plan for any excavation, grading, and stockpiling activities. Implementation of BMP's as outlined in these plans will minimize the potential for releases to groundwater or surface water and will detail response actions to be undertaken should a spill occur.

d. **Proposed measures to reduce or control surface, ground, and runoff water impacts, if any:**

Temporary measures will be taken during excavation, grading and stockpiling to control erosion and the transport of sediment from the work area. The Project will be managed under an Ecology NPDES General Permit for Construction Activity. Prior to the start of interim actions, the Port will develop a Stormwater Pollution Prevention Plan (SWPPP) in accordance with Ecology's Surface Water Management Manual and the NPDES General Permit for Construction Activity.

4. **Plants**

a. Check or circle types of vegetation found on site:

- deciduous tree: alder, maple, aspen, other: small cottonwoods
 evergreen tree: fir, cedar, pine, other
 shrubs
 grass
 pasture
 crop or grain
 wet soil plants: cattail, buttercup, bullrush, skunk cabbage,
 water plants: water lily, eelgrass, milfoil, other: cattails along margins of two ponds
 other types of vegetation: minor amounts of opportunistic weeds and blackberry vines

b. **What kind and amount of vegetation will be removed or altered?**

No significant amount of vegetation will be removed or altered as a result of the proposed Project.

c. **List any threatened or endangered species known to be on or near the site.**

None known.

d. **Proposed landscaping, use of native plants, or other measures to preserve or enhance vegetation on the site, if any:**

None.

5. **Animals**

a. **Underline any birds or animals which have been observed on or near the site or are known to be on or near the site:**

**birds: hawk, heron, eagle, songbirds, other: canada geese
mammals: deer, bear, elk, beaver, other: transient coyotes
fish: salmon, trout, herring, shellfish, other:**

b. **List any threatened or endangered species known to be on or near the site.**

There are no known endangered species on the site. With respect to near the site, the following is known:

On May 24, 1999, the National Marine Fisheries Service (NMFS) formalized listing of Puget Sound Chinook salmon as threatened under the Endangered Species Act (ESA). This species occurs in the Puyallup River drainage and Commencement Bay.

The U.S. Fish and Wildlife Service (USFWS) announced the listing of Coastal-Puget Sound bull trout (*Salvelinus confluentus*) as threatened on October 28, 1999. Bull trout occur in the Puyallup River drainage and Commencement Bay.

On November 15, 2005 the National Marine Fisheries Service (NMFS) formalized listing of Southern Resident Orcas as endangered under the Endangered Species Act. The pods listed may transit Commencement Bay during summer months.

Other listed species that could occur in the Project area include the humpback whale (*Megaptera novaeangliae*), Steller sea lion (*Eumetopias jubatus*), leatherback sea turtle (*Dermochelys coriacea*) and bald eagle (*Haliaeetus leucocephalus*). This list of species is based on information provided by NMFS and USFWS with respect to another Port project in Commencement Bay (Blair Waterway Infrastructure Improvements Project).

On May 11, 2007, the National Marine Fisheries Service (NMFS) formalized listing of Puget Sound Steelhead (*Oncorhynchus mykiss*) as threatened under the Endangered Species Act, to take effect June 11, 2007. Steelhead may occur in the Puyallup River drainage and Commencement Bay.

On April 28, 2010 the National Marine Fisheries Service (NMFS) formalized listing of three species of rockfish. The Puget Sound/Georgia Basin Distinct Population Segments of yelloweye (*Sebastes ruberrimus*) and canary rockfish (*Sebastes penniger*) are listed as threatened, and bocacio (*Sebastes paucispinis*) are listed as endangered.

The project will not impact existing habitat nor will it have an adverse impact on water quality or fish life.

c. Is the site part of a migration route? If so, explain.

The Tacoma tideflats is part of the Pacific flyway for migrating birds. The Project site consists of upland areas that do not abut marine waters. Adult salmon migrate from Commencement Bay into the Puyallup River, Hylebos Creek, or Wapato Creek systems to spawn, and juveniles migrate downstream into Commencement Bay as smolts.

d. Proposed measures to preserve or enhance wildlife, if any:

None planned.

6. Energy and Natural Resource

a. What kinds of energy (electrical, natural gas, oil, wood stove, solar) will be used to meet the completed project's energy needs? Describe whether it will be used for heating, manufacturing, etc.

No energy will be required as part of the completed Project.

b. Would your project affect the potential use of solar power by adjacent properties? If so, generally describe.

No.

c. What kinds of energy conservation features are included in the plans for this proposal? List other proposed measures to reduce or control energy impacts, if any

None.

7. **Environmental Health**

- a. **Are there any environmental health hazards, including exposure to toxic chemicals, risk of fire and explosion, spill, or hazardous waste, that could occur as a result of this proposal? If so, generally describe.**

Spent pot liner contains cyanide and PAH compounds; both are regulated contaminants. Solid wastes buried at the Rod Mill Landfill also contain regulated contaminants. These materials will be handled, removed, and disposed of in an approved manner. In addition, some construction equipment will use fuels or petroleum products that have an inherent potential risk of fire, explosion or spill. Contractors working onsite will be required to have approved health and safety, spill prevention, and erosion control plans to protect workers, the public and the environment.

- 1) **Describe special emergency services that might be required.**

During work activities there is the potential for an accident which could require medical attention and emergency services. Routine fire protection, police and medical aid provided by and/or within the City of Tacoma are available. Contractors will establish and follow appropriate health and safety plans. No special emergency service needs are anticipated.

- 2) **Proposed measures to reduce or control environmental health hazards, if any:**

All applicable state and federal safety guidelines will be adhered to in the implementation of the proposed Project. Contractors will follow appropriate health and safety plans and shall have United States Department of Labor, Occupational Safety & Health Administration (OSHA) Hazardous Waste Operations and Emergency Response (HAZWOPER) training, as necessary. The need for additional measures is not anticipated.

b. **Noise**

- 1) **What types of noise exist in the area which may affect your project (for example: traffic, equipment, operation, other)?**

The site is located in an industrial area. Noise is not expected to affect the project.

- 2) **What types and levels of noise would be created by or associated with the project on a short-term or a long-term basis (for example: traffic, construction, operation, other)? Indicate what hours noise would come from the site.**

Noise will be generated during implementation of the Project; however, that noise will be consistent with the surrounding industrial areas.

- 3) **Proposed measures to reduce or control impacts, if any:**

Restrict construction activities to approved work hours.

8. **Land and Shoreline Use**

- a. **What is the current use of the site and adjacent properties?**

The Project site currently is vacant land. The site is occasionally used for automobile storage, recycling of construction materials and contractor laydown area.

Properties adjacent to the Project site are owned by the Puyallup Tribe of Indians, BPA, City of Tacoma and Port of Tacoma. A portion of the Tribe property to the north is developed and has recently been used as a lumber transloading facility. The remaining portions of the Tribe property to the west and southeast are vacant. Property to the south is owned by BPA, and is used for a power substation. The City of Tacoma owns the adjacent Taylor Way and Alexander Avenue. The abutting Port property is part of the Port's industrial land inventory. Several small office buildings are present at the southwest corner of the 96 acre site.

b. Has the site been used for agriculture? If so, describe.

No.

c. Describe any structure on the site.

Five small office buildings are located at the southwest corner of the site and have been used as field offices; however, they are currently vacant. One small sampling shed is present along Taylor Way, at the outlet to one of the two ponds.

d. Will any structures be demolished?

No. Concrete slabs and asphalt pavement will be removed at the Spent Pot Liner area.

e. What is the current zoning?

The Project site is zoned "PMI" Port Maritime Industrial District.

f. What is the current comprehensive plan designation of the site?

High Intensity

g. If applicable, what is the current shoreline master program designation of the site?

NA.

h. Has any part of the site been classified as an "environmentally sensitive" area? If so, specify.

None known

i. Approximately how many people would reside or work in the completed project?

None.

j. Approximately how many people would the completed project displace?

None.

k. Proposed measures to avoid or reduce displacement impacts, if any:

None needed.

l. Proposed measures to insure the proposal is compatible with existing and projected land uses and plans, if any:

The site use proposed is compatible and consistent with the surrounding uses and with current zoning and comprehensive plan designations for this site. Remedial actions planned during the project will restore contaminated portions of the site to productive use.

9. Housing

a. Approximately how many units would be provided, if any? Indicate whether high, middle, or low-income housing.

Not applicable.

b. Approximately how many units, if any, would be eliminated? Indicate whether high, middle, or low-income housing.

Not applicable.

c. Proposed measures to reduce or control housing impacts, if any:

Not applicable.

10. Aesthetics

a. What is the tallest height of any proposed structure(s), not including antennas; what is the principle exterior building material(s) proposed?

No structures are proposed.

b. What views in the immediate vicinity would be altered or obstructed?

None.

c. Proposed measures to reduce or control aesthetic impacts, if any:

None.

11. Light and Glare

a. What type of light and glare will the proposal produce? What time of day would it mainly occur?

None.

b. Could light or glare from the finished project be a safety hazard or interfere with views?

No.

- c. **What existing off-site source of light or glare may affect your proposal?**

None.

- d. **Proposed measures to reduce or control light and glare impacts, if any:**

None.

12. **Recreation**

- a. **What designated and informal recreational opportunities are in the immediate vicinity?**

Recreational fishing and boating occur in Commencement Bay and the nearby waterways.

- b. **Would the proposed project displace any existing recreational uses? If so, describe.**

No.

- c. **Proposed measures to reduce or control impacts on recreation, including recreation opportunities to be provided by the project or applicant, if any:**

None needed, as the project does not interfere with any access to recreational opportunities.

13. **Historic and Cultural Preservation**

- a. **Are there any places or objects listed on, or proposed for, national, state, or local preservation registers known to be on or next to the site? If so, general describe.**

There are no places or objects on or next to the sites known to be listed or proposed for national, state, or local preservation registers.

- b. **Generally describe any landmarks or evidence of historic, archaeological, scientific, or cultural importance known to be on or next to the site.**

None known.

- c. **Proposed measures to reduce or control impacts, if any:**

None needed.

14. **Transportation**

- a. **Identify public streets and highways serving the site, and describe proposed access to the existing street system. Show on site plans, if any.**

The site has two existing entrances along Taylor Way and two existing entrances along Alexander Avenue. The majority of the project traffic is expected to enter and exit the site via the southern Taylor Way entrance. This entrance has been in continual use since 1968.

- b. **Is site currently served by public transit? If not, what is the approximate distance to the nearest transit stop?**

The site is no longer served by public transit. The nearest bus stop is in Fife.

- c. **How many parking spaces would the completed project have? How many would the project eliminate?**

The project will neither create nor eliminate any parking spaces. Contractor temporary parking will be provided on the Project site.

- d. **Will the proposal require any new roads or streets, or improvements to existing roads or streets, not including driveways? If so, generally describe (indicate whether public or private).**

No.

- e. **Will the project use (or occur in the immediate vicinity of) water, rail, or air transportation? If so, generally describe.**

Yes; the project is located on parcels in the vicinity of water and rail transportation given the proximity of the locations to the Port of Tacoma. There will be no impact on either.

- f. **How many vehicular trips per day would be generated by the completed project? If known, indicate when peak volumes would occur.**

The Project will not generate vehicular trips when it is completed, therefore, peak volumes or times will not be effected.

- g. **Proposed measures to reduce or control transportation impacts, if any:**

None.

15. **Public Services**

- a. **Would the project result in an increased need for public services (for example: fire protection, police protection, health care, schools, other)? If so, generally describe.**

No.

- b. **Proposed measures to reduce or control direct impacts to public services, if any.**

Not applicable.

16. **Utilities**

- a. **Underline utilities currently available at the site: electricity, natural gas, water, refuse service, telephone, sanitary sewer, septic system, other.**

The above identified utilities are available on the property, but not within close proximity to any planned construction.

- b. Describe the utilities that are proposed for the project, the utility providing the service, and the general construction activities on the site or in the immediate vicinity which might be needed.

No new utility services will be required as a result of the completion of the proposed project.

C. SIGNATURE

The above answers are true and complete to the best of my knowledge. I understand that the lead agency is relying on them to make its decision.

Signature: _____

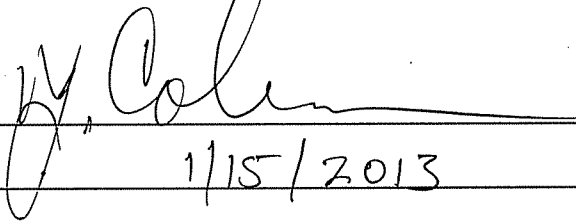

Date Submitted: _____

1/15/2013

WAC 197-11-970 Determination of nonsignificance (DNS).

DETERMINATION OF NONSIGNIFICANCE

Description of proposal: The project involves the following elements pursuant to Agreed Order No. DE – 5698, or as deemed necessary by Ecology:

- Interim Action Work Plan(s) and Interim Action(s), including supporting documentation. These may include the removal of contaminated materials or capping, as appropriate.

Proponent: Port of Tacoma _____

Location of proposal, including street address, if any: Generally described as 3400 Taylor Way, Tacoma, WA 98421

Lead agency: Washington State Department of Ecology _____

The lead agency for this proposal has determined that it does not have a probable significant adverse impact on the environment. An environmental impact statement (EIS) is not required under RCW 43.21C.030 (2)(c). This decision was made after review of a completed environmental checklist and other information on file with the lead agency. This information is available to the public on request.

- There is no comment period for this DNS.
- This DNS is issued after using the optional DNS process in WAC 197-11-355. There is no further comment period on the DNS.
- This DNS is issued under WAC 197-11-340(2); the lead agency will not act on this proposal for 14 days from the date below. Comments must be submitted by February 11, 2013.

Responsible official: Rebecca Lawson P.E., LHG

Position/title: Regional Section Manager, Toxics Cleanup Program, Phone: (360) 407-6241

Address: Southwest Regional Office, P.O. Box 47775, Olympia, WA 98504-7775

Date 1/15/2013 Signature Rebecca S. Lawson

(OPTIONAL)

- You may appeal this determination to (name) _____
at (location) _____
no later than (date) _____
by method _____

You should be prepared to make specific factual objections.

Contact _____ to read or ask about the procedures for SEPA appeals.

- There is no agency appeal.

Stacy Lane

From: TSCPortland@wm.com
Sent: Thursday, July 25, 2013 2:13 PM
To: Stacy Lane
Cc: markm@clearcreekcon.com; darenn@clearcreekcon.com; lwimmer@wm.com
Subject: Profile OR321468 has been approved on WMSolutions.com



THINK GREEN®

JULY 25, 2013

RE: Notice of Profile Approval: #OR321468

Profile Number:	OR321468
Waste Stream:	LF04 - CAMU-eligible soil containing spent pot lining
Generator Name:	Port of Tacoma
Disposal Site:	Chemical Waste Management (Hazardous Waste Facility)
Expiration Date:	03/19/2014

Dear Stacy Lane,

We are pleased to inform you that Profile OR321468 has been approved by our Portland Technical Service Center. Your Waste Approval Terms and Conditions can be found on either your *Profile Form* or *Approval Form*. Both documents are available as a PDF in the *Approved Tab* in your wmsolutions.com account.

Please feel free to email us at TSCPortland@wm.com or call 800-963-4776 with any questions.

Thank you for choosing Waste Management, Inc.

Portland
7227 NE 55th Avenue
Portland, OR 97218
800-685-8001
TSCPortland@wm.com

You are receiving this message as a registered customer of WMSolutions.com.

Waste Management respects your privacy. To review our Privacy Policy, [click here](#).

© 2011 Waste Management, Inc. All rights reserved.

Interim Action Construction Drawings

BINDING EDGE

PORT OF TACOMA

FORMER KAISER FACILITY INTERIM ACTION SPL AREA AND ROD MILL AREA CLOSED LANDFILL PROJECT NO. 092837 CONTRACT NO. 069646

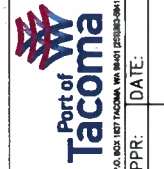

LANDAU ASSOCIATES
130 2nd AVENUE S.
EDMONDS, WA 98020
(425) 778-0907, FAX (425) 778-0409
MARK: REVISION: BY: DATE:
APPR: DATE:



CHECKED BY: DATE
PROJECTED BY: DATE
DIRECTOR ENG. DATE: PROJ. ENGR DATE
MAY 22, 2013 | PRINTED BY: | PLUDWIG May 17, 2013
TACOMA, WA 98401-1837

APPROVED BY: DAKOTA CHAMBERLAIN
MAY 22, 2013
DIRECTOR ENG. DATE: PROJ. ENGR DATE
MAY 22, 2013 | PRINTED BY: PLUDWIG May 17, 2013
TACOMA, WA 98401-1837

**FORMER KAISER FACILITY
INTERIM ACTION
COVER SHEET**

G1.0
SHEET 1 OF 15
CONT./CONS: 069646
PROJECT NO: 092837
PHASE: BID SET

THIS DRAWING IS THE PROPERTY OF THE PORT OF TACOMA AND SHALL NOT BE USED ON OTHER WORK, DISCLOSED, COPIED, IN WHOLE OR IN PART, WITHOUT WRITTEN PERMISSION

PORT COMMISSIONERS:

CONSTANCE T. BACON
DONALD C. JOHNSON
RICHARD P. MARZANO
DON MEYER
CLARE PETRICH

PORT STAFF:

JOHN WOLFE
Chief Executive Officer

SUE MAUERMANN
Director of Facilities
Development

DAKOTA CHAMBERLAIN, PE
Director of Engineering

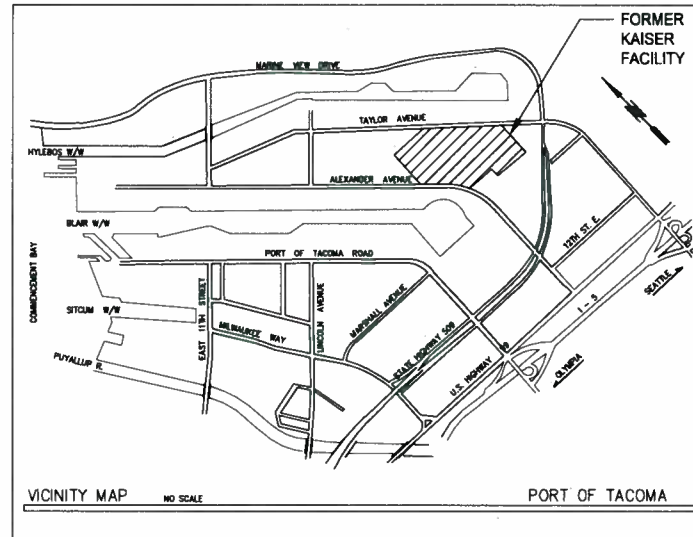

ENVIRONMENTAL/GEOTECHNICAL ENGINEER:

LANDAU ASSOCIATES
CONTACT: DAVE FISCHER, P.E.
130 2ND AVENUE SOUTH
EDMONDS, WA 98020
(425) 778-0907

BASE SURVEY:

APEX ENGINEERING PLLC
CONTACT: MEL GARLAND, P.L.S.
2601 SOUTH 35TH STREET, SUITE 200
TACOMA, WA 98409
(253) 473-4494

DRAWING LIST		
SHEET DESIGNATION	SHEET #	SHEET TITLE
G1.0	1	COVER SHEET
G2.0	2	LEGEND, SYMBOLS, AND ABBREVIATIONS
G3.0	3	DATUM AND GENERAL NOTES
C1.0	4	SITE ACCESS, HAUL ROUTES, AND STAGING AREA
C2.0	5	TESC PLAN, NOTES, AND DETAILS
C3.0	6	SPL AREA DEMOLITION PLAN
C3.1	7	SPL AREA EXCAVATION PLAN
C3.2	8	SPL AREA EXCAVATION SECTIONS
C3.3	9	SPL AREA BACKFILL AND GRADING PLAN
C3.4	10	SPL AREA STORM DRAINAGE PLAN
C4.0	11	ROD MILL CLOSED LANDFILL AREA EXCAVATION PLAN
C4.1	12	ROD MILL CLOSED LANDFILL AREA EXCAVATION SECTIONS
C4.2	13	ROD MILL CLOSED LANDFILL AREA BACKFILL AND GRADING PLAN
C5.0	14	RECTIFIER YARD AREA BACKFILL AND GRADING PLAN
---	15	TOPOGRAPHIC SURVEY

PORT OF TACOMA FILE: V11180331010_04016d Set092837-G1.0



ABBREVIATIONS

A/C	- ASPHALT CONCRETE	MW	- MONITORING WELL
ASPH	- ASPHALT	MTCA	- MODEL TOXICS CONTROL ACT
APPROX	- APPROXIMATE	NTS	- NOT TO SCALE
BGS	- BELOW GROUND SURFACE	PORT	- PORT OF TACOMA
BOT	- BOTTOM	RCRA	- RESOURCE CONSERVATION AND RECOVERY ACT
BMP	- BEST MANAGEMENT PRACTICE	RMLF	- ROD MILL LANDFILL
CAMU	- CORRECTIVE ACTION MANAGEMENT UNIT	SD	- STORM DRAINAGE
CDF	- CONTROLLED DENSITY FILL	SF	- SQUARE FEET
CITY	- CITY OF TACOMA	SPL	- SPENT POT LINING
CONC	- CONCRETE	SWPPP	- STORMWATER POLLUTION PREVENTION PLAN
CPAHS	- CARCINOGENIC POLYCYCLIC AROMATIC HYDROCARBONS	TEMP	- TEMPORARY
CPE	- CORRUGATED POLYETHYLENE	TESC	- TEMPORARY EROSION AND SEDIMENT CONTROL
ECOLOGY	- WASHINGTON STATE DEPARTMENT OF ECOLOGY	TYP	- TYPICAL
ELEV	- ELEVATION	VERT	- VERTICAL
FT	- FEET		
HORZ	- HORIZONTAL		
HASP	- HEALTH AND SAFETY PLAN		
LF	- LINEAR FEET		
MAX	- MAXIMUM		
MIN	- MINIMUM		
MISC	- MISCELLANEOUS		
MLLW	- MEAN LOWER LOW WATER		
MUTCD	- MANUAL ON UNIFORM TRAFFIC CONTROL DEVICES		

SYMBOLS

•	BOLLARD/ GAURD POST
GATE	FENCE GATE
+	FIRE HYDRANT - 2 PORT
⊕	FIRE HYDRANT - 3 PORT
⊗	LANDSCAPE LIGHT
⊞	LIGHT J-BOX
☀	LIGHT STANDARD
⊞	LIGHT VAULT
↑	POWER GUY ANCHOR
⊙	PDWER GUY POLE
⊕	PDWER POLE
⊞	PDWER PULL BOX
⊞	POWER RISER POWER
⊞	POWER TRANSFORMER
⊞	PDWER VAULT
⊞	SIGN
Y	STORM DRAIN CULVERT
⊙	STORM MAN HOLE
⊞	WATER METER
⊗	WATER VALVE
⊞	WATER VAULT

SURVEY LEGEND

⊙	EXISTING SURVEY MONUMENT
⊙	EXISTING SURVEY MONUMENT - SECONDARY
+	SURVEY CONTROL POINT
⊞	STORMWATER CATCH BASIN
⊞	STORMWATER CULVERT
⊞	MONITORING WELL
+	SIGN
ASPH	ASPHALT
CONC	CONCRETE
GRAVEL	GRAVEL
---	STDRM DRAIN LINE
x x	CHAIN LINK FENCE
---	TOP OF SLOPE
---	TDE OF SLOPE
---	MAJOR CONTOUR
---	MINOR CONTOUR

GENERAL

SEE SHEET NO. X.XX MATCHLINE

[+15']	ELEVATION POINT (TOP OF ELEMENT INDICATED)
X1 X ²	POINT
R X.XX	RADIUS
→	SLOPE
---	PAVEMENT SAWCUT LINE
---	TEMPORARY CONSTRUCTION ROUTE
---	FORMER BUILDING FOOTPRINT
⊞	SILT FENCE
⊞	TEMPORARY ORANGE CONSTRUCTION EXCLUSION FENCE
---	DRAINAGE DIVERSION
---	COIR LOG
---	CHAINLINK FENCE
---	FLOW LINE
ASPH	ASPHALT
CONC	CONCRETE
GRAVEL	GRAVEL
---	SOIL
---	SOIL STABILIZATION (EROSION CONTROL BLANKET & HYDROSEEDING)
---	HYDROSEEDING
---	QUARRY SPALLS

TITLES / SECTIONS/ DETAIL / VIEW IDENTIFIERS

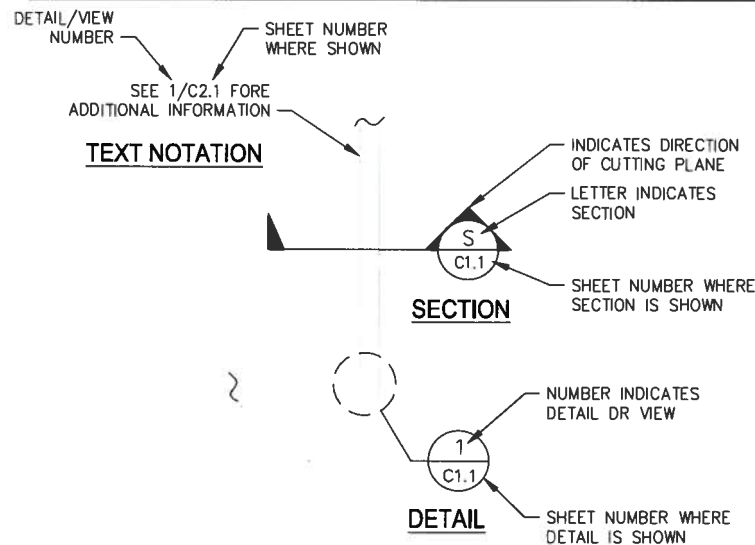
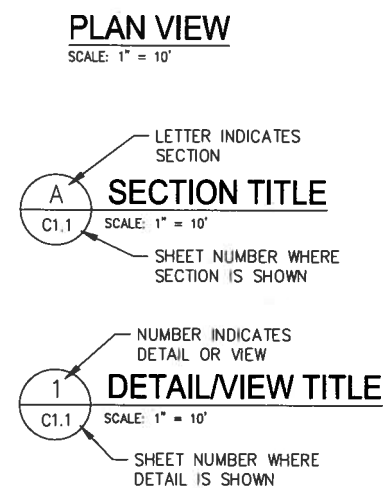

DEMOLITION

ASPH	ASPHALT
CONC	CONCRETE
-----	PIPE REMOVED



LANDAU ASSOCIATES
130 2nd AVENUE S.
EDMONDS, WA 98020
(425) 778-0807, FAX (425) 778-6409



CHECKED BY	DATE
PROJECTED BY	DATE
PRINTED BY	DATE
PROJECT ADDRESS	DATE
TACOMA, WA 98401-1837	

FORMER KAISER FACILITY INTERIM ACTION
LEGEND, SYMBOLS, AND ABBREVIATIONS

G2.0
SHEET 2 OF 15
PROJECT NO: 092837
PHASE: BID SET



TEMPORARY EROSION AND SEDIMENT CONTROL NOTES:

- APPROVAL OF THE TEMPORARY EROSION AND SEDIMENT CONTROL (TESC) PLAN DOES NOT CONSTITUTE AN APPROVAL OF PERMANENT ROAD AND/OR DRAINAGE DESIGN (E.G., SIZE AND LOCATION OF ROADS, PIPES, RESTRICTORS, CHANNELS, RETENTION BMPS, UTILITIES, ETC.) BUT IS AN APPROVAL OF TESC MEASURES ONLY.
- IMPLEMENTATION OF THE TESC PLAN AND THE CONSTRUCTION, MAINTENANCE, REPLACEMENT, AND UPGRADING OF THE TESC BEST MANAGEMENT PRACTICES (BMPs) IS THE RESPONSIBILITY OF THE CONTRACTOR UNTIL SUBSTANTIAL COMPLETION, UNLESS OTHERWISE DIRECTED BY THE PORT.
- CONTRACTOR SHALL MARKUP AND RESUBMIT FOR PORT APPROVAL THE UPDATED TESC PLANS INDICATING LOCATIONS AND SEQUENCING OF MEASURES (FACILITIES AND BMPs) TO BE INSTALLED.
- BOUNDARIES OF THE CLEARING LIMITS SHOWN ON THE TESC PLAN SHALL BE CLEARLY MARKED (WITH SURVEY TAPE, HIGH VISIBILITY FENCING, HIGH VISIBILITY SILT FENCING, HIGH VISIBILITY PAINT, LATH WITH SURVEY TAPE, OR TEMPORARY FENCING AS APPROPRIATE AND AS SHOWN ON THE PLANS) PRIOR TO EXCAVATION OF SOILS.
- TESC MEASURES (FACILITIES AND BMPs) SHOWN ON THE TESC PLAN ARE THE MINIMUM REQUIREMENTS FOR ANTICIPATED SITE CONDITIONS. DURING THE CONSTRUCTION PERIOD, THE TESC FACILITIES SHALL BE UPGRADED (E.G., ADDITIONAL SUMPS, PUMPS, STORAGE TANKS, RELOCATION OF DITCHES AND SILT FENCING, ETC.) AS NEEDED FOR UNEXPECTED STORM EVENTS AND MODIFIED TO ACCOUNT FOR CHANGING SITE CONDITIONS. THEREFORE, DURING THE COURSE OF CONSTRUCTION, THE CONTRACTOR SHALL ADDRESS ANY CHANGED OR NEW CONDITIONS THAT MAY BE CREATED BY THE CONTRACTOR'S ACTIVITIES AND PROVIDE ADDITIONAL TESC MEASURES THAT MAY BE NEEDED TO PROTECT ADJACENT PROPERTIES AT NO ADDITIONAL COST TO THE PORT.
- TESC MEASURES SHALL BE CONSTRUCTED PRIOR TO OR IN CONJUNCTION WITH ALL CLEARING AND EXCAVATION ACTIVITIES, AND IN SUCH A MANNER AS TO ENSURE THAT SEDIMENT-LADEN WATER DOES NOT ENTER SURFACE WATERS, DRAINAGE SYSTEMS, ADJACENT PROPERTIES, AND/OR VIOLATE APPLICABLE WATER STANDARDS.
- STABILIZED CONSTRUCTION ENTRANCES, WHEEL WASH FACILITIES, AND EQUIPMENT DECONTAMINATION FACILITIES SHALL BE INSTALLED AT THE BEGINNING OF CONSTRUCTION AND MAINTAINED FOR THE DURATION OF THE PROJECT. ADDITIONAL MEASURES SHALL BE IMPLEMENTED AS REQUIRED TO ENSURE THAT ALL PAVED AREAS ARE KEPT CLEAN FOR THE DURATION OF THE PROJECT.
- TESC MEASURES SHALL BE INSPECTED DAILY BY THE CONTRACTOR DURING ACTIVE WORK AND MAINTAINED AS NECESSARY TO ENSURE THEIR CONTINUED PROPER FUNCTIONING. WRITTEN RECORDS SHALL BE KEPT OF WEEKLY SITE INSPECTIONS AND SUBMITTED TO THE PORT ON A WEEKLY BASIS.
- THE CONTRACTOR SHALL MAINTAIN A FULLY STOCKED SPILL KIT ON SITE AT ALL TIMES.
- ANY AREA NEEDING ADDITIONAL TESC MEASURES, BUT NOT REQUIRING IMMEDIATE ATTENTION, SHALL BE ADDRESSED WITHIN 5 DAYS.
- TESC MEASURES ON INACTIVE SITE AREAS SHALL BE MAINTAINED A MINIMUM OF ONCE A MONTH OR WITHIN 48 HOURS FOLLOWING A STORM EVENT AND IN ACCORDANCE WITH THE LATEST EDITION OF THE STORMWATER MANAGEMENT MANUAL FOR WESTERN WASHINGTON, VOLUME II, CONSTRUCTION STORMWATER POLLUTION PREVENTION, BY THE WASHINGTON STATE DEPARTMENT OF ECOLOGY.
- AT NO TIME SHALL SEDIMENT BE ALLOWED TO ACCUMULATE WITHIN A CATCH BASIN. ALL CATCH BASINS AND CONVEYANCE LINES WITHIN AND NEAR AREAS OF CONTAMINATED SOIL REMOVAL SHALL BE BLOCKED OR PLUGGED.
- POLYETHYLENE SHEETING OR AN EROSION CONTROL BLANKET SHALL BE APPLIED TO STABILIZE SOIL BERMS.
- THE CONTRACTOR SHALL DESIGNATE A PERSON TO BE TESC SUPERVISOR. THE TESC SUPERVISOR SHALL HAVE THEIR CERTIFIED EROSION AND SEDIMENT CONTROL LEAD (CESCL) CERTIFICATION AND BE RESPONSIBLE FOR MAINTENANCE AND REVIEW OF TESC MEASURES AND FOR COMPLIANCE WITH ALL PERMIT CONDITIONS RELATING TO TESC. THE TESC SUPERVISOR MUST BE AVAILABLE FOR RAPID RESPONSE TO TESC PROBLEMS. THE CONTRACTOR SHALL PROVIDE THE NAME AND PHONE NUMBERS TO REACH THE TESC SUPERVISOR, AT ALL TIMES, TO THE PORT AND ENGINEER.
- SHOULD TESC MEASURES NOT BE PROPERLY INSTALLED AND MAINTAINED, THE PORT MAY STOP ALL WORK NOT PERTAINING TO THE CORRECTION OF TESC PROBLEMS UNTIL TESC MEASURES ARE RETURNED TO THE PROPER OPERATION, AT NO ADDITIONAL COST TO THE PORT.

TEMPORARY EROSION AND SEDIMENT CONTROL NOTES (CONT):

- ALL TESC BMPs SHALL BE MAINTAINED IN A SATISFACTORY CONDITION UNTIL SUCH TIME THAT CONSTRUCTION IS COMPLETED, PERMANENT DRAINAGE FACILITIES ARE OPERATIONAL, AND THE POTENTIAL FOR EROSION HAS PASSED.
- AT A MINIMUM, EROSION AND SEDIMENT CONTROL FACILITIES SHALL BE MAINTAINED MONTHLY, OR FOLLOWING EACH RUNOFF PRODUCING STORM, TO ENSURE PROPER OPERATION OF ALL EROSION AND SEDIMENT CONTROL MEASURES.
- THE PUBLIC RIGHT-OF-WAY SHALL BE KEPT CLEAN. TRACKING OF MUD AND DEBRIS FROM THE SITE WILL NOT BE ALLOWED. FAILURE TO COMPLY WITH THIS CONDITION WILL RESULT IN ALL WORK ON THE SITE BEING STOPPED UNTIL THE ISSUE IS CORRECTED, AT NO COST TO THE PORT.
- WHEN NECESSARY, SCRAPING AND SWEEPING OF STREETS, SIDEWALKS, AND FLOWLINES SHALL BE CONDUCTED WITH A VACUUM SWEEPER OR OTHER APPROVED MEANS.
- VACUUM/CLEAN UP SLURRY CREATED FROM SAW-CUTTING OF SLABS AND PAVEMENTS IMMEDIATELY AFTER OR CONCURRENT WITH CUTTING.
- THE WASHINGTON STATE CLEAN AIR ACT REQUIRES THE USE OF ALL KNOWN, AVAILABLE, AND REASONABLE MEANS OF CONTROLLING AIR POLLUTION, INCLUDING DUST. DUST CAN BE CONTROLLED BY WETTING EXPOSED SOILS, WASHING TRUCK WHEELS BEFORE THEY LEAVE THE SITE, AND INSTALLING AND MAINTAINING ROCK CONSTRUCTION ENTRANCES. CONSTRUCTION VEHICLE TRACK-OUT IS A MAJOR SOURCE OF DUST AND ANY EVIDENCE OF TRACK-OUT CAN TRIGGER FINES FROM THE DEPARTMENT OF ECOLOGY OR THE PUGET SOUND AIR POLLUTION CONTROL AGENCY THAT WILL BE THE RESPONSIBILITY OF THE CONTRACTOR.
- CATCH BASIN INSERTS SHALL BE PROVIDED AND PROPERLY MAINTAINED IN ALL EXISTING AND NEW CATCH BASINS WITHIN THE CONSTRUCTION LIMITS. AT NO TIME SHALL MORE THAN 6 INCHES OF SEDIMENT BE ALLOWED TO ACCUMULATE WITHIN A CATCH BASIN INSERT.
- THE CONTRACTOR SHALL IMPLEMENT LINEAR RUN-ON CONTROLS TO PREVENT WATER FROM ENTERING THE EXCAVATED AREAS.
- PORTABLE SANITARY FACILITIES SHALL BE LOCATED AT LEAST 25 FEET FROM ANY STORM WATER INLET OR WATER BODY AND SHALL BE SERVICED REGULARLY AS NEEDED.
- STATIONARY EQUIPMENT (E.G., GENERATORS, LIGHT STANDS) CONTAINING ANY AMOUNT OF FUELS AND OR OILS SHALL BE EQUIPPED WITH SECONDARY CONTAINMENT.
- TESC BMPs SHALL BE REMOVED PRIOR TO FINAL COMPLETION UNLESS OTHERWISE DIRECTED BY THE PORT.

PERMANENT EROSION CONTROL:

- CONTRACTOR SHALL MAINTAIN BMPs THROUGH PERMIT TERMINATION OR WARRANTED PERIOD, WHICHEVER IS FIRST.

GENERAL CONSTRUCTION NOTES:

- ALL WORKMANSHIP AND MATERIALS SHALL BE IN ACCORDANCE WITH THE PORT OF TACOMA STANDARDS, THE CITY OF TACOMA STANDARDS, AND AS SPECIFIED IN THE SPECIFICATIONS FOR THIS CONTRACT.
- APPROXIMATE LOCATIONS OF EXISTING UTILITIES HAVE BEEN OBTAINED FROM AVAILABLE RECORDS AND ARE SHOWN FOR CONVENIENCE. THE CONTRACTOR SHALL CALL 811 NUMBER PRIOR TO CONSTRUCTION AND SHALL BE RESPONSIBLE FOR VERIFICATION OF LOCATIONS AND AVOIDING DAMAGE TO ALL UTILITIES. CONTRACTOR SHALL NOT COMMENCE CLEARING AND/OR GRADING ACTIVITIES UNTIL ALL KNOWN UTILITIES ARE MARKED AND ALL UTILITY PURVEYORS HAVE BEEN NOTIFIED AND HAVE PROVIDED INFORMATION ON UNKNOWN FACILITIES.
- IF CONFLICTS WITH EXISTING UTILITIES ARISE DURING CONSTRUCTION, THE CONTRACTOR SHALL NOTIFY THE PORT AND THE ENGINEER. ANY CHANGES REQUIRED SHALL BE APPROVED BY THE PORT PRIOR TO COMMENCEMENT OF RELATED CONSTRUCTION ON THE PROJECT.
- A COPY OF THE APPROVED PLANS MUST BE ON THE JOB SITE WHENEVER CONSTRUCTION IS IN PROGRESS.
- THE CONTRACTOR SHALL BE RESPONSIBLE FOR PROVIDING ADEQUATE SAFEGUARDS, SAFETY DEVICES, PROTECTIVE EQUIPMENT, FLAGGERS, AND ANY OTHER NEEDED ACTIONS TO PROTECT THE LIFE, HEALTH, AND SAFETY OF THE PUBLIC, AND TO PROTECT PROPERTY IN CONNECTION WITH THE PERFORMANCE OF WORK COVERED BY THE CONTRACT. ANY WORK WITHIN THE TRAVELED RIGHT-OF-WAY SHALL CONFORM WITH THE CITY OF TACOMA TRAFFIC CONTROL HANDBOOK AND PART SIX (6) OF THE MUTCD FOR GENERAL REQUIREMENTS.
- EQUIPMENT AND VEHICLES THAT HAVE BEEN IN CONTACT WITH POTENTIALLY CONTAMINATED SITE MATERIALS MUST PASS THROUGH THE DECONTAMINATION WORK PAD FACILITY PRIOR TO LEAVING THE SITE.
- WORK PERFORMED SHALL BE IN ACCORDANCE TO THE SPL AREA AND ROD MILL AREA CLOSED LANDFILL INTERIM ACTION WORK PLANS.

GENERAL EXCAVATION NOTES:

- CONTRACTOR SHALL USE A SMOOTH BLADE BUCKET TO CAREFULLY EXCAVATE SOILS IN THE SPENT POT LINING AREA UNDER THE OBSERVATION OF THE PORT'S REPRESENTATIVE. EXCAVATION AT THE SPENT POT LINING AREA SHALL START ALONG THE NORTHERN BOUNDARY AND WORK TOWARDS THE SOUTH.
- CONTRACTOR SHALL USE A SMOOTH BLADE BUCKET DURING THE FINAL PASS TO CAREFULLY EXCAVATE SOILS IN THE ROD MILL LANDFILL AREA UNDER THE OBSERVATION OF THE PORT'S REPRESENTATIVE. EXCAVATION AT THE ROD MILL LANDFILL AREA SHALL START ALONG THE SOUTHERN BOUNDARY AND WORK TOWARDS THE NORTH.
- CONTRACTOR SHALL USE SOIL MATERIAL FROM THE STOCKPILE AREA STARTING AT THE NORTHERN EDGE/END OF THE STOCKPILE AND WORKING TOWARDS THE SOUTH.

GENERAL FILL NOTES:

- CONTRACTOR SHALL OBTAIN CONFIRMATION FROM THE PORT THAT CONTAMINATED MATERIALS HAVE BEEN ADEQUATELY REMOVED IN EACH AREA PRIOR TO START OF BACKFILLING.

SUGGESTED CONSTRUCTION SEQUENCE:

- HOLD THE PRE-CONSTRUCTION MEETING WITH THE PORT AND THE ENGINEER.
- MARK CLEARING EXCAVATION LIMITS AS NOTED ON THE DRAWINGS.
- INSTALL T.E.S.C. MEASURES (FACILITIES AND BMPs) ON AND ADJACENT TO THE SITE AS SHOWN ON THESE PLANS AS APPLICABLE.
- CONDUCT EXCAVATION AND BACKFILLING WORK IN THE FOLLOWING ORDER UNLESS OTHERWISE APPROVED BY THE PORT.
 - SPENT POT LINING (SPL) AREA
 - ROD MILL CLOSED LANDFILL AREA
 - RECTIFIER YARD AREA
- DEMOLISH AND REMOVE SPL AREA CONCRETE SLABS/FOUNDATIONS AND ASPHALT PAVEMENTS AS CALLED OUT ON SHEET C3.0.
- EXCAVATE AND REMOVE CONTAMINATED SOIL IN THE SPL AREA. UPON APPROVAL FROM THE PORT, BACKFILL TO SPECIFIED FINISHED GRADES.
- EXCAVATE AND REMOVE SOIL AND DEBRIS IN THE ROD MILL LANDFILL AREA. UPON APPROVAL FROM THE PORT, BACKFILL TO SPECIFIED FINISHED GRADES.
- PLACE FILL IN THE RECTIFIER YARD AREA.
- CONDUCT SITE RESTORATION ACTIVITIES AND SUBMIT RECORD DRAWINGS TO THE PORT IN ACCORDANCE WITH SPECIFICATION SECTIONS 01 71 23 AND 01 77 00.

HORIZONTAL DATUM:

WASHINGTON STATE PLANE COORDINATE SYSTEM, SOUTH ZONE, NAD 83/07.

AS DERIVED FROM GLOBAL POSITIONING SYSTEM (GPS) TIES TO PORT OF TACOMA SURVEY CONTROL MONUMENTS AS SHOWN ON PORT OF TACOMA (POT) 2007 SURVEY CONTROL MAP TITLED "BLAIR-HYLEBOS PENINSULA SURVEY CONTROL MAP", PREPARED BY PARAMETRIX, DATED JANUARY 7, 2008.

POT MONUMENT #135 N 706689.81, E 1178944.75
POT MONUMENT #175 N 708849.50, E 1176475.70
HELD INVERSE BEARING BETWEEN #175 AND #135, BEING SOUTH 48°49'26" EAST.

NOTE:
1. ALL DISTANCES SHOWN ARE GROUND VALUES.

VERTICAL DATUM:

PORT OF TACOMA - MLLW
BENCHMARK: POT MONUMENT #175
2" BRASS DISK ON THE SW SIDE OF TAYLOR WAY
ELEV: 16.15'

VERTICAL DATUM CONVERSION:

SUBTRACT 6.17' TO CONVERT MLLW TO CITY OF TACOMA (NGVD '29) VERTICAL DATUM.

MLLW ELEV. - 6.17' = NGVD 29 ELEV.



LANDAU ASSOCIATES
130 2nd AVENUE S.
EDMONDS, WA 98020
(425) 778-0907 FAX (425) 778-6409



CHECKED BY: DATE
DATE: 05/12/2013
PROJECT: 092837
PHASE: BID SET

FORMER KAISER FACILITY
INTERIM ACTION
DATUM AND GENERAL NOTES

G3.0
SHEET 3 OF 15



THIS DRAWING IS THE PROPERTY OF THE PORT OF TACOMA AND SHALL NOT BE USED ON OTHER WORK, DISCLOSED, COPIED, IN WHOLE OR IN PART, WITHOUT WRITTEN PERMISSION



- NOTES:**
1. AERIAL MAP OBTAINED FROM GOOGLE EARTH PRO 2010.

(X) NOTES:

1. THE ONLY SITE ACCESS AVAILABLE TO THE CONTRACTOR IS LOCATED AT THIS GATED ENTRANCE ALONG TAYLOR WAY. CONTRACTOR TO PROVIDE FLAGGER FOR TRUCKS TURNING ONTO AND OFF TAYLOR WAY AS NECESSARY. CONTRACTOR SHALL SHUT AND LOCK THE SITE ACCESS GATE AT THE END OF EACH WORKDAY.
2. THE ACCESS ROAD IS THE MAIN HAUL ROUTE AND ACCESS INTO THE SITE. CONTRACTOR SHALL COORDINATE USE AND MAINTENANCE OF THE ACCESS ROAD WITH THE PORT.
3. CONTRACTOR STAGING AREAS ARE AVAILABLE FOR TEMPORARY FACILITIES.
4. EQUIPMENT LEAVING CONTAMINATED SOIL EXCAVATION AREAS SHALL BE DECONTAMINATED AS SPECIFIED IN SPECIFICATION 01 35 45.
5. MATERIAL FROM THE SOIL STOCKPILE SHALL BE THE PRIMARY SOURCE OF ONSITE FILL MATERIAL, STARTING AT THE NORTH END OF THE STOCKPILE AND WORKING TOWARDS THE SOUTH.
6. SURFICIAL SAND IN THIS AREA TO BE REMOVED AND USED TO BACKFILL THE ROD MILL LANDFILL EXCAVATION AREA. DISTURBED AREAS TO BE REGRADED AND RECOMPACTED TO PROMOTE DRAINAGE.
7. STOCKPILES OF MATERIAL TO BE USED AS BACKFILL IN THE RECTIFIER YARD AND ROD MILL LANDFILL AREAS.
8. WASTE/DEBRIS PILE TO REMAIN OR BE REMOVED BY OTHERS.
9. EXISTING CRUSHED ASPHALT STOCKPILES SHALL BE USED AS SURFACING MATERIAL IN THE SPL AREA, RECTIFIER YARD AREA, AND PORTIONS OF THE ROD MILL AREA.
10. SURFICIAL CRUSHED ASPHALT SURFACING IN THIS AREA SHALL BE SCRAPED AND STOCKPILED FOR USE AS SURFACING MATERIAL IN OTHER PROJECT AREAS. DISTURBED AREAS TO BE REGRADED AND RECOMPACTED TO PROMOTE DRAINAGE.
11. CONTRACTOR SHALL PROVIDE APPROXIMATELY 70 LF OF TEMPORARY FENCING AT THE SOUTHWEST ACCESS ROAD OFF OF ALEXANDER AVENUE NORTH. FENCING SHALL BE REMOVED PRIOR TO FINAL COMPLETION.
12. EXISTING CRUSHED CONCRETE STOCKPILES TO BE USED AS FILL ONLY IN THE AREAS APPROVED BY THE PDRT.



LANDAU ASSOCIATES
 130 2nd AVENUE S.
 EDMONDS, WA 98020
 (425) 778-0907, FAX (425) 778-6409



APPROVED:	CHECKED BY:	DATE:
<i>[Signature]</i>		
DIRECTOR	PROJ. ENGR	DATE
MAY 17 2013	May 17, 2013	
PRINTED BY: rludivig		
PORT ADDRESS: ONE SITCUM PLAZA		
TACOMA, WA 98401-1837		

FORMER KAISER FACILITY
INTERIM ACTION
 SITE ACCESS, HAUL ROUTES, AND STAGING AREA

C1.0
 SHEET 4 OF 15
 CONT/CONS: 069646
 PROJECT NO: 092837
 PHASE: BID SET

THIS DRAWING IS THE PROPERTY OF THE PORT OF TACOMA AND SHALL NOT BE USED ON OTHER WORK, DISCLOSED, COPIED, IN WHOLE OR IN PART, WITHOUT WRITTEN PERMISSION

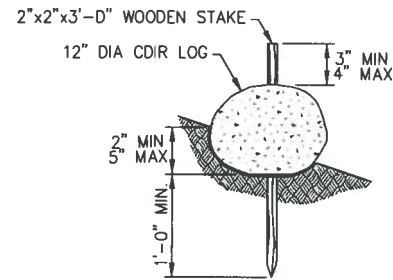

NOTES:

- COIR LOGS SHALL BE IN ACCORDANCE WITH THE WSDOT STANDARD SPECIFICATION SECTION 9-14.5(7). PROVIDE AND INSTALL AS SHOWN ON THE PLANS.
- SECURELY KNOT EACH END OF COIR LOG. ABUT ADJACENT COIR LOGS TIGHTLY, END TO END, WITHOUT OVERLAPPING THE ENDS.
- PILOT HOLES MAY BE DRIVEN THROUGH THE COIR LOGS AND INTO THE SOIL WHEN SOIL CONDITIONS REQUIRE.

1 COIR LOGS
C2.0 SCALE: N.T.S.

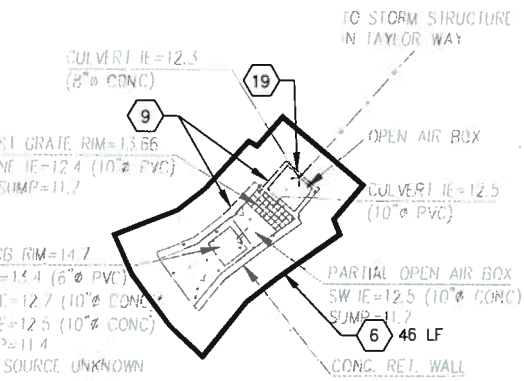
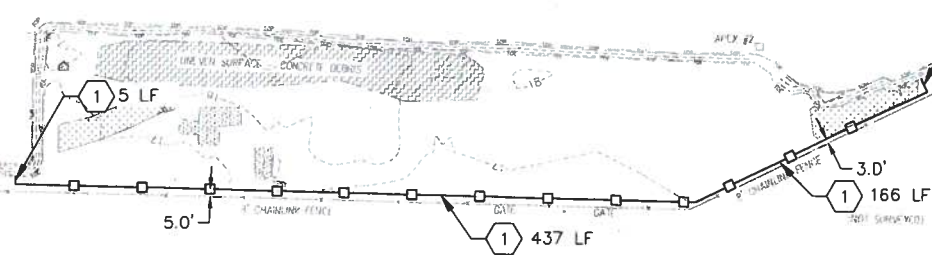

A CONCRETE VAULT DETAIL
C2.0 SCALE: 1" = 6'

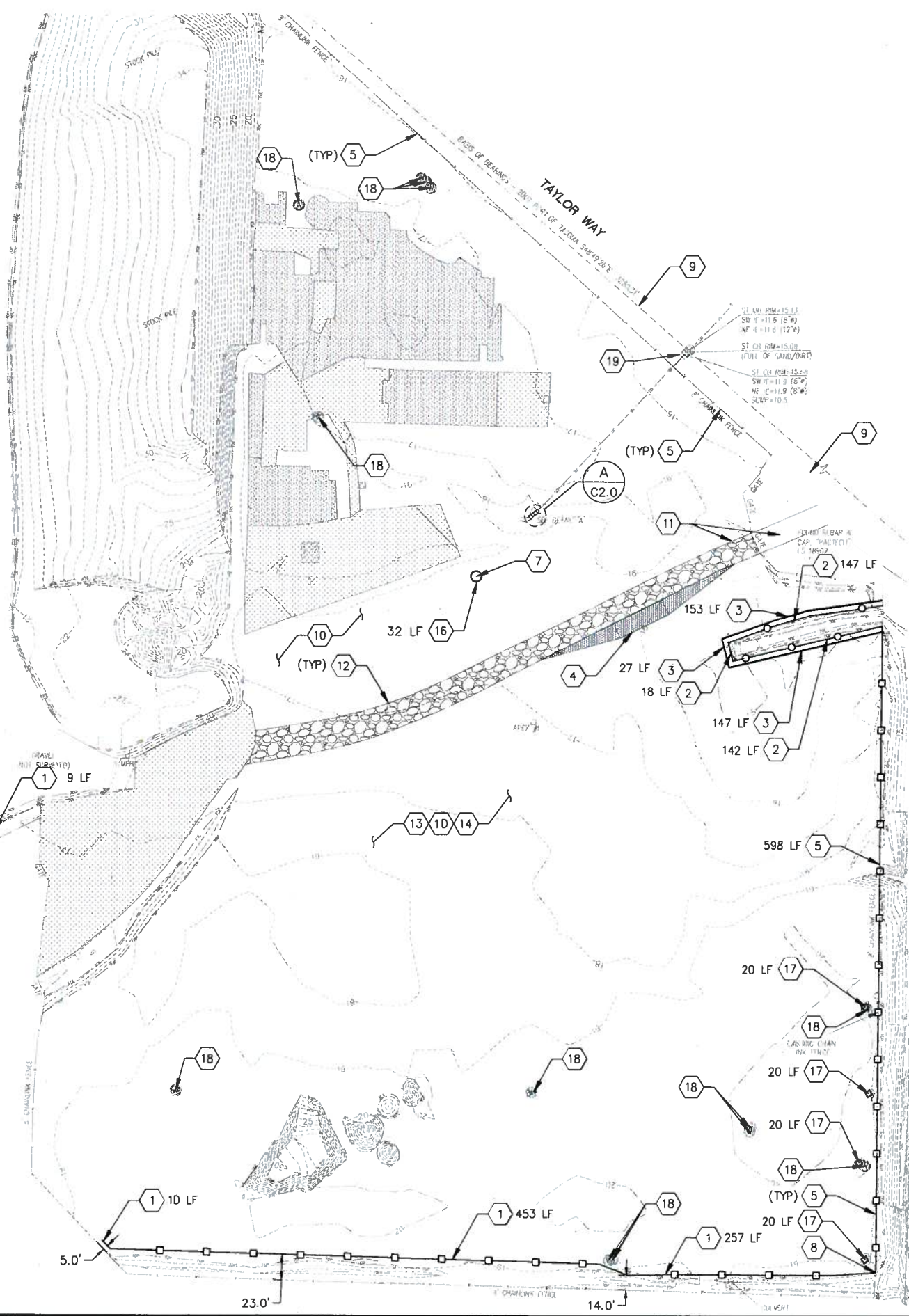

TESC NOTES:

- SILT FENCING TO BE PROVIDED AND INSTALLED IN ACCORDANCE WITH ECOLOGY'S BMP C233.
- HIGH VISIBILITY (SAFETY) FENCING TO BE PROVIDED NEAR THE TOP OF SLOPE AND INSTALLED IN ACCORDANCE WITH ECOLOGY'S BMP C103.
- CDIR LOGS TO BE PROVIDED 5' FROM HIGH VISIBILITY FENCING AND INSTALLED PER DETAIL 1/C2.0.
- PROVIDE WHEEL WASH IN ACCORDANCE WITH ECOLOGY'S BMP C106. LOCATION TO BE REVIEWED AND APPROVED BY THE PORT.
- PROVIDE OR REPAIR (AS NEEDED) AND MAINTAIN SILT FENCING ATTACHED TO CHAINLINK FENCE.
- COIR LOGS TO BE PROVIDED AROUND EXISTING CONCRETE VAULT AND INSTALLED PER DETAIL 1/C2.0.
- CATCH BASIN INLET PROTECTION SHALL BE PROVIDED IN NEW CATCH BASIN AND INSTALLED IN ACCORDANCE WITH ECOLOGY'S BMP C220.
- CONNECT/TIE SILT FENCING TO EXISTING CHAINLINK FENCE.
- PROVIDE STORM DRAIN INLET PROTECTION FOR THE EXISTING CONCRETE VAULT IN THE SPL AREA AND ALONG TAYLOR WAY IN THE FIRST TWO GRATED DOWNSTREAM CATCH BASINS FROM THE ENTRANCE AND INSTALLED IN ACCORDANCE WITH ECOLOGY'S BMP C220.
- PROVIDE CONSTRUCTION ROADS AND PARKING AREA STABILIZATION IN ACCORDANCE WITH ECOLOGY'S BMP C107.
- PROVIDE/UPGRADE CONSTRUCTION ENTRANCE/EXIT IN ACCORDANCE WITH ECOLOGY'S BMP C105.
- PROVIDE DUST CONTROL AS APPLICABLE IN ACCORDANCE WITH ECOLOGY'S BMP C140.
- HAVE APPROPRIATE EROSION CONTROL MATERIALS ON HAND AND LOCATED IN THE CONTRACTOR'S AREA IN ACCORDANCE WITH ECOLOGY'S BMP C150.
- PROVIDE MATERIAL DELIVERY, STORAGE, AND CONTAINMENT IN THE CONTRACTOR'S AREA IN ACCORDANCE WITH ECOLOGY'S BMP C153.
- NOT USED.
- COIR LOGS SHALL BE PROVIDED 5 FT AWAY AND AROUND THE NEW CATCH BASIN AND INSTALLED PER DETAIL 1/C2.0.
- PROTECT EXISTING GROUNDWATER MONITORING WELLS AND PROVIDE HIGH VISIBILITY FENCING AROUND THE WELLS IN ACCORDANCE WITH ECOLOGY'S BMP C103.
- VERIFY WITH THE PORT THAT THE GROUNDWATER MONITORING WELLS ARE DECOMMISSIONED (BY OTHERS) PRIOR TO DEMOLITION OF ANY REMAINING WELL MONUMENTS, BOLLARDS, AND CONCRETE SEALS. CONTRACTOR SHALL DEMOLISH REMAINING WELL MONUMENTS, BOLLARDS, AND CONCRETE SEALS AS DIRECTED BY THE PORT.
- CLEAN STORM CATCH BASIN/STRUCTURES AND REMOVE SEDIMENTS PRIOR TO ANY EARTH DISTURBING ACTIVITIES.



Port of Tacoma
P.O. BOX 187 TACOMA, WA 98401 (360)841-1000

L'ANDOU ASSOCIATES
130 2ND AVENUE S.
EDMONDS, WA 98020
(425) 778-0807, FAX (425) 778-8409

DATE: _____
APPR: _____
BY: _____
REVISION: _____
MARK: _____

FORMER KAISER FACILITY INTERIM ACTION
TESC PLAN, NOTES, AND DETAILS

CHECKED BY: _____ DATE: _____

APPROVED BY: _____ DATE: _____

PROJECT ENG. DATE: _____

DIRECTOR: _____ DATE: _____

PROJECT NO.: 092837

PHASE: BID SET

TOWNSHIP: 21 NORTH RANGE: 3 EAST SECTION: SW 1/4-36

DAT-HRZ: WA83-SF VERT: MLLW 19.39' @ Tide 22 1933

DRAWING SCALE: AS NOTED

TACOMA, WA 98401-1837

C2.0

SHEET 5 OF 15

THIS DRAWING IS THE PROPERTY OF THE PORT OF TACOMA AND SHALL NOT BE USED ON OTHER WORK, DISCLOSED, COPIED, IN WHOLE OR IN PART, WITHOUT WRITTEN PERMISSION

BINDING EDGE

PORT OF TACOMA FILE: V:\118003\010\0408\Bid Set\092837-C3.0

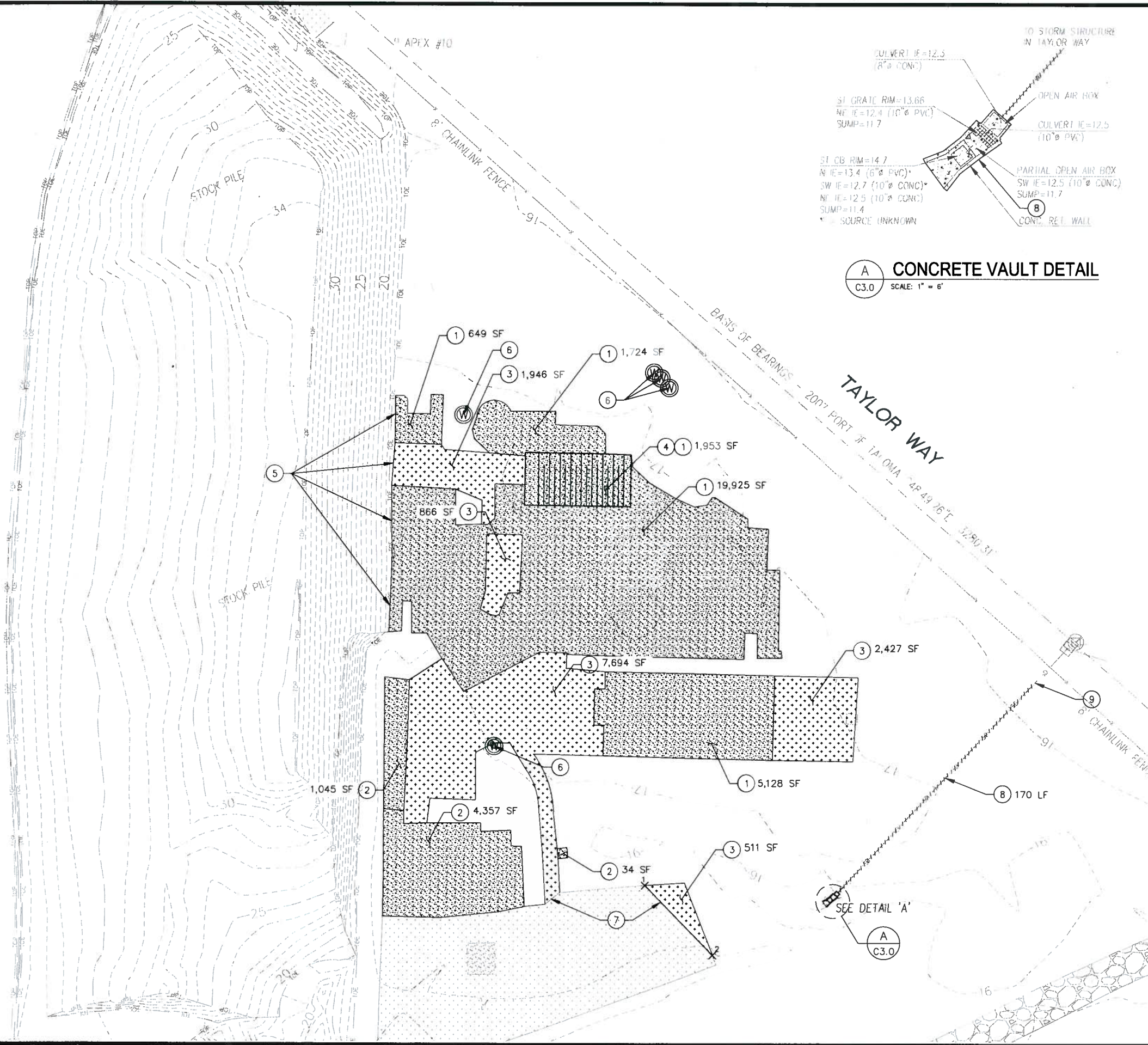

A CONCRETE VAULT DETAIL
 C3.0 SCALE: 1" = 6'

POINT TABLE		
POINT #	NORTHING	EASTING
1	707894.99	1177149.07
2	707853.93	1177188.89

(X) DEMOLITION NOTES:

- REMOVE REINFORCED CONCRETE SLABS IN SECTIONS. THE REINFORCED CONCRETE SLAB THICKNESS VARIES BUT IS ESTIMATED TO BE MAX 16 INCHES. CONCRETE SECTIONS SHALL BE RUBBLIZED TO APPROX 8 TO 10 INCH SIZE AT A PORT APPROVED PROCESSING LOCATION AND STOCKPILED FOR REUSE AS BACKFILL IN THE ROD MILL LANDFILL AND RECTIFIER YARD AREAS.
- REMOVE REINFORCED CONCRETE SLABS IN SECTIONS. THE REINFORCED CONCRETE SLAB THICKNESS VARIES BUT IS ESTIMATED TO BE APPROX 10 INCHES. CONCRETE SECTIONS SHALL BE RUBBLIZED TO MAX 8 TO 10 INCH SIZE AT A PORT APPROVED PROCESSING LOCATION AND STOCKPILED FOR REUSE AS BACKFILL IN THE ROD MILL LANDFILL AND RECTIFIER YARD AREAS.
- REMOVE ASPHALT PAVEMENT IN SECTIONS. THE ASPHALT THICKNESS IS APPROX 4 INCHES. ASPHALT SECTIONS SHALL BE RUBBLIZED TO MAX 8 TO 10 INCHES AT A PORT APPROVED PROCESSING LOCATION AND STOCKPILED FOR REUSE AS BACKFILL IN THE ROD MILL LANDFILL AND RECTIFIER YARD AREAS.
- REMOVE REINFORCED CONCRETE SLAB CONTAINING METAL RAILS. THERE ARE 16 RAILS IN WHICH HALF OF THEM ARE ABOUT 24 FT LONG AND THE REMAINDER ARE ABOUT 31 FT LONG. THE REINFORCED CONCRETE SLAB THICKNESS IS ESTIMATED TO BE APPROX 16 INCHES.
- SLABS AND PAVEMENT MAY EXTEND UNDER CLEAN SOIL STOCKPILE AREA. REMOVE PORTIONS OF SOIL STOCKPILE AS REQUIRED TO EXPOSE SLABS AND PAVEMENT FOR DEMOLITION.
- VERIFY WITH THE PORT THAT THE GROUNDWATER MONITORING WELLS ARE DECOMMISSIONED (BY OTHERS) PRIOR TO DEMOLITION OF THE REMAINING WELL MONUMENTS, BOLLARDS, AND CONCRETE SEALS.
- REMOVE ASPHALT PAVEMENT UP TO THIS EDGE.
- AS PART OF SPL AREA SOIL EXCAVATION, EXISTING REINFORCED CONCRETE VAULT STRUCTURE AND CONCRETE PIPE TO BE DEMOLISHED, REMOVED, CLEANED, AND RUBBLIZED TO MAX 8 TO 10 INCH SIZE AT A PORT APPROVED PROCESSING LOCATION AND STOCKPILED FOR REUSE AS BACKFILL IN THE ROD MILL LANDFILL AND RECTIFIER YARD AREAS.
- AFTER COMPLETION OF SPL AREA SOIL EXCAVATION, PROVIDE FOR CONNECTION OF NEW STORM DRAIN PIPE. SEE SHEET C3.4 FOR NEW STORM DRAIN PIPE INFORMATION.

GENERAL DEMOLITION NOTES:

- RECYCLE MATERIALS TO THE EXTENT POSSIBLE.
- ABANDONED PIPES AND CONDUITS SHALL BE PLUGGED WITH CDF AT THE EDGE OF THE EXCAVATION AREAS.
- THE CONTRACTOR SHALL SUBMIT THE LOCATION OF ITS PROPOSED ASPHALT AND CONCRETE PROCESSING AREA FOR PORT APPROVAL.
- REMOVE/CLEAN ALL SOIL AND/OR WASTE MATERIALS OF CONCRETE AND ASPHALT SURFACES PRIOR TO RUBBLIZATION AND STOCKPILING.
- RUBBLIZED CONCRETE AND ASPHALT SHALL BE STOCKPILED FOR LATER REUSE AS EXCAVATION BACKFILL MATERIAL IN THE ROD MILL LANDFILL AND RECTIFIER YARD AREAS.

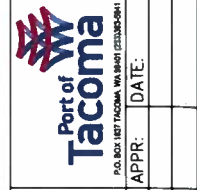

LANDAU ASSOCIATES
 130 2nd AVENUE S.
 EDMONDS, WA 98020
 (425) 778-0907 FAX (425) 778-9409



CHECKED BY: DATE
 PROJECTED BY: DATE
 DIRECTOR ENG. DATE: MAY 22, 2013
 PRINTED BY: r.ludvig May 17, 2013
 PORT ADDRESS: ONE SITCUM PLAZA
 TACOMA, WA 98401-1837

FORMER KAISER FACILITY INTERIM ACTION
 SPL AREA
 DEMOLITION PLAN
 TOWNSHIP: 21 NORTH RANGE: 3 EAST SECTION: SW 1/4-36
 DAT-HRZ: WA83-SF VERT: MLLW 19.39' @ Tide 22 1933
 PARCEL: 77 DRAWING SCALE: AS NOTED

C3.0
 SHEET 6 OF 15
 CONT/CONS: 069846
 PROJECT NO: 092837
 PHASE: BID SET

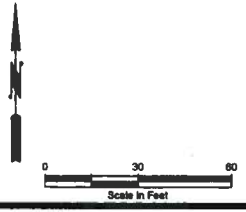

THIS DRAWING IS THE PROPERTY OF THE PORT OF TACOMA AND SHALL NOT BE USED ON OTHER WORK, DISCLOSED, COPIED, IN WHOLE OR IN PART, WITHOUT WRITTEN PERMISSION

BINDING EDGE

PORT OF TACOMA FILE: V:\118003\010\040\Bld S61092837-C3.1

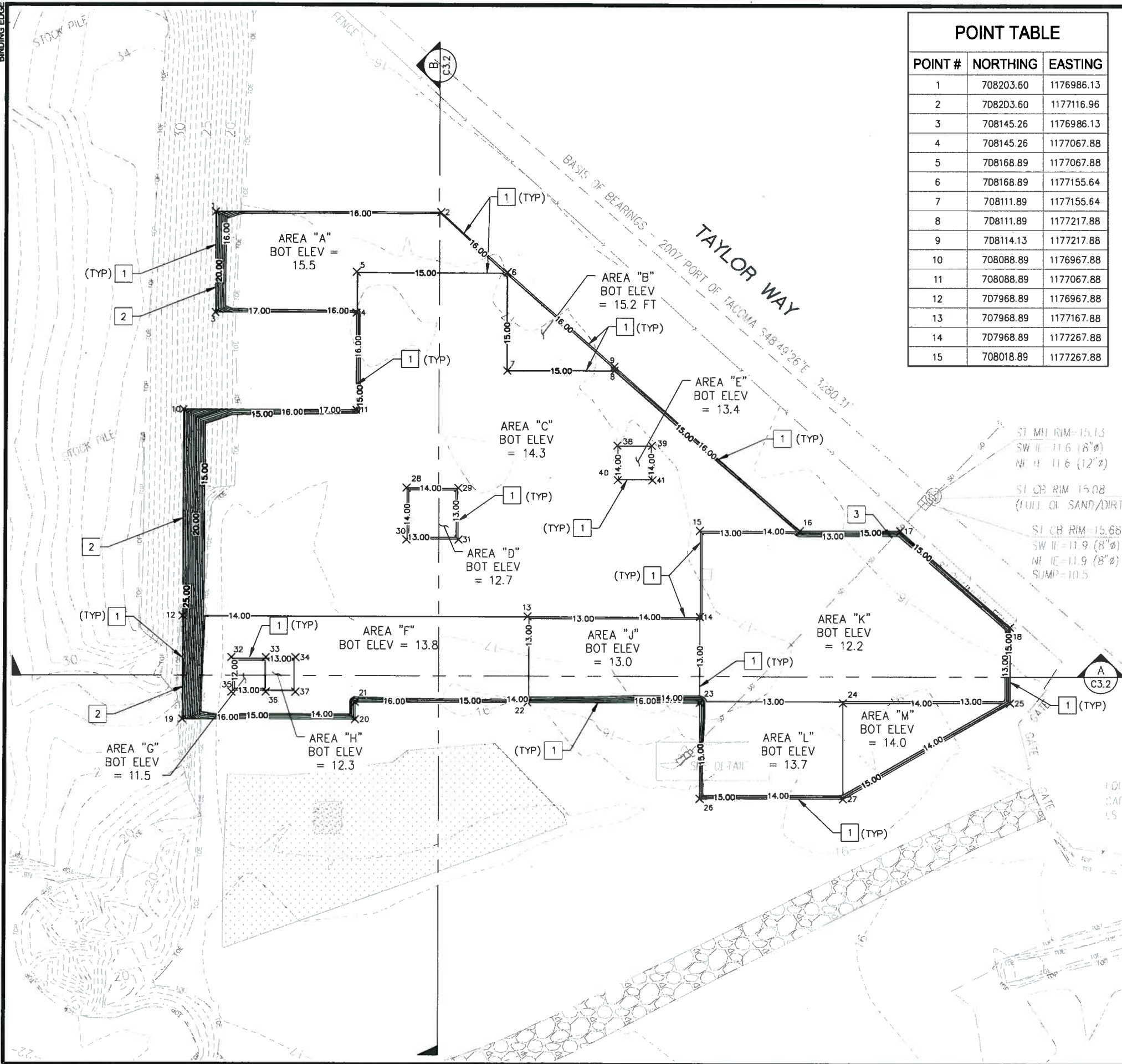

POINT TABLE		
POINT #	NORTHING	EASTING
1	708203.60	1176986.13
2	708203.60	1177116.96
3	708145.26	1176986.13
4	708145.26	1177067.88
5	708168.89	1177067.88
6	708168.89	1177155.64
7	708111.89	1177155.64
8	708111.89	1177217.88
9	708114.13	1177217.88
10	708088.89	1176967.88
11	708088.89	1177067.88
12	707968.89	1176967.88
13	707968.89	1177167.88
14	707968.89	1177267.88
15	708018.89	1177267.88

POINT TABLE		
POINT #	NORTHING	EASTING
16	708018.89	1177326.12
17	708018.89	1177384.33
18	707963.01	1177448.36
19	707908.89	1176967.88
20	707908.89	1177067.88
21	707918.89	1177067.88
22	707918.89	1177167.88
23	707918.89	1177267.88
24	707918.89	1177351.06
25	707918.89	1177448.36
26	707863.20	1177267.88
27	707863.20	1177351.06
28	708043.50	1177097.44
29	708043.50	1177127.44
30	708013.50	1177097.44

POINT TABLE		
POINT #	NORTHING	EASTING
31	708013.50	1177127.44
32	707944.68	1176996.17
33	707944.68	1177016.17
34	707944.68	1177033.32
35	707924.68	1176996.17
36	707924.68	1177016.17
37	707924.68	1177033.32
38	708068.35	1177219.67
39	708068.35	1177239.67
40	708048.35	1177219.67
41	708048.35	1177239.67

[X] SPL AREA SOIL EXCAVATION NOTES:

- ASSUMED BOUNDARY OF EXCAVATION WITH 1H:1V SIDE SLOPES AND UP TO 6 INCHES OF SOIL REMOVED BELOW CURRENTLY IDENTIFIED SPL ZONE MATERIAL. ACTUAL EXTENT AND DEPTH OF SPL ZONE MATERIAL AND ASSOCIATED CONTAMINATED SOIL TO BE REMOVED FOR DISPOSAL SHALL BE BASED ON DETERMINATIONS BY THE PORT'S REPRESENTATIVE AND LABORATORY RESULTS OBTAINED DURING CONTRACTOR'S SOIL EXCAVATION ACTIVITIES.
- REMOVE PORTIONS OF THE CLEAN SOIL STOCKPILE AS REQUIRED TO ACCESS SPL ZONE MATERIAL AND ASSOCIATED CONTAMINATED SOIL THAT EXTENDS UNDER THE TOE OF THE SOIL STOCKPILE.
- POTHOLE, STAKE, AND FLAG SEGMENT OF EXISTING STORM DRAIN PIPE TO REMAIN. CAREFULLY EXCAVATE AND EXPOSE EXISTING STORM DRAIN PIPE AT CONNECTION OF NEW STORM DRAIN PIPE IN A MANNER THAT PREVENTS DAMAGE TO PIPE. REPAIR ANY DAMAGE TO PIPE CAUSED BY EXCAVATION AND BACKFILLING ACTIVITIES. SEE SHEET C3.4 FOR NEW STORM DRAIN PIPE INFORMATION.

GENERAL SPL AREA SOIL EXCAVATION NOTES:

- CAREFULLY SCRAPE OFF AND STOCKPILE CLEAN SURFICIAL FILL MATERIAL PRESENT OVER CERTAIN SPL EXCAVATION AREAS, TO THE EXTENT AND DEPTH DIRECTED BY THE PORT'S REPRESENTATIVE BASED ON DETERMINATIONS DURING SHALLOW SOIL POTHOLES AND SCRAPING CONDUCTED BY CONTRACTOR.
- USE A SMOOTH BLADE BUCKET TO CAREFULLY EXCAVATE SPL AREA SOILS UNDER THE OBSERVATION OF THE PORT'S REPRESENTATIVE.
- IF REQUIRED BY THE WASTE DISPOSAL AUTHORIZATION, CONTRACTOR TO CONDUCT ANY ADDITIONAL ANALYTICAL TESTING REQUIRED FOR MATERIAL DISPOSAL AT THE SUBTITLE C HAZARDOUS WASTE LANDFILL AT NO ADDITIONAL COST TO THE PORT.
- IF ANY DEEPER EXCAVATIONS EXTEND BELOW GROUND WATER LEVEL, SATURATED MATERIALS SHALL BE EXCAVATED AND PLACED IN TEMPORARY SOIL STOCKPILES WITHIN THE EXCAVATION AREA WHERE EXCESS WATER IS ALLOWED TO DRAIN PRIOR TO LOADING FOR OFFSITE DISPOSAL.
- UNLESS OTHERWISE DIRECTED BY THE PORT, CONSTRUCTION STORMWATER SHALL BE MANAGED BY EVAPORATION AND/OR INFILTRATION AT LOCATIONS APPROVED BY THE PORT.
- OBTAIN CONFIRMATION FROM THE PORT THAT CONTAMINATED MATERIALS HAVE BEEN ADEQUATELY REMOVED IN EACH AREA PRIOR TO START OF BACKFILLING IN THAT AREA.
- ABANDONED PIPES AND CONDUITS SHALL BE PLUGGED WITH CDF AT THE EDGE OF THE EXCAVATION AREAS.

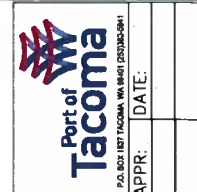

LA LINDAU ASSOCIATES
 130 2ND AVENUE S.
 EDMONDS, WA 98020
 (425) 778-0907, FAX (425) 778-9409



FORMER KAISER FACILITY INTERIM ACTION SPL AREA EXCAVATION PLAN

CHECKED BY: DATE
 PROJECTED BY: DATE
 DIRECTOR ENG. DATE: May 17, 2013
 PRINTED BY: rldw May 17, 2013
 PORT ADDRESS: ONE SITCUM PLAZA
 TACOMA, WA 98401-1837

TOWNSHIP: 21 NORTH RANGE: 3 EAST SECTION: SW 1/4-36
 DAT-HRZ: WAB3-SF VERT: M.L.W. 19.39 @ Tide 22.1933
 PARCEL: 77 DRAWING SCALE: AS NOTED

C3.1
 SHEET 7 OF 15
 CONT/CONS: 069646
 PROJECT NO: 092837
 PHASE: BID SET



THIS DRAWING IS THE PROPERTY OF THE PORT OF TACOMA AND SHALL NOT BE USED ON OTHER WORK, DISCLOSED, COPIED, IN WHOLE OR IN PART, WITHOUT WRITTEN PERMISSION

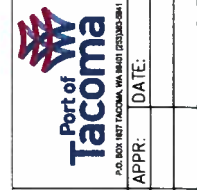
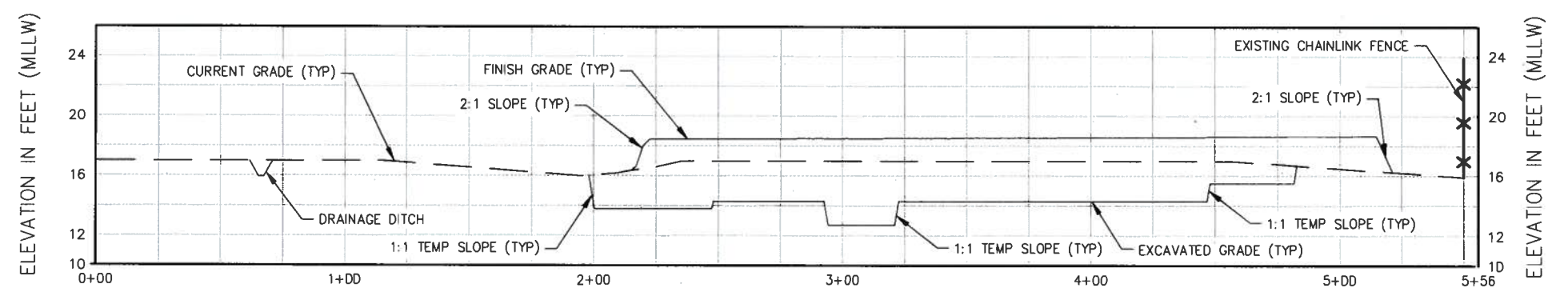
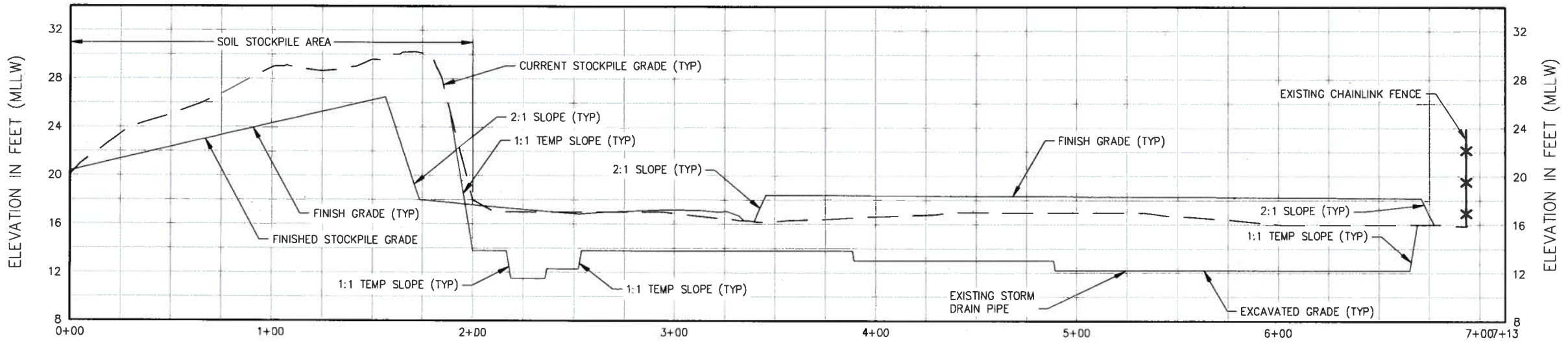

LA LINDAU ASSOCIATES
 180 2nd AVENUE S.
 EDMONDS, WA 98020
 (425) 778-0907, FAX (425) 778-6409



CHECKED BY	DATE
PROJECTED BY	DATE
PROJECTED BY	DATE
PROJECTED BY	DATE

APPROVED
 DIRECTOR ENG. DATE
 MAY 17 2013
 PRINTED BY: rhudwig
 PORT ADDRESS: ONE SITCUM PLAZA
 TACOMA, WA 98401-1837

FORMER KAISER FACILITY INTERIM ACTION
 SPL AREA
 EXCAVATION SECTIONS
 TOWNSHIP: 21 NORTH RANGE: 3 EAST SECTION: SW 1/4-36
 DAT-HRZ: WAB3-SF VERT: MLLW 19.39' @ Tide 22 1933
 [DRAWING SCALE: AS NOTED]

C3.2
 SHEET 8 OF 15
 CONT/CONS: 069646
 PROJECT NO: 092837
 PHASE: BID SET

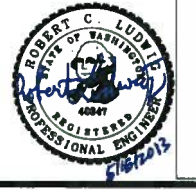

THIS DRAWING IS THE PROPERTY OF THE PORT OF TACOMA AND SHALL NOT BE USED ON OTHER WORK DISCLOSED, COPIED, IN WHOLE OR IN PART, WITHOUT WRITTEN PERMISSION

BINDING EDGE

PORT OF TACOMA FILE: V11180331010.04081d S61092837-C3.3

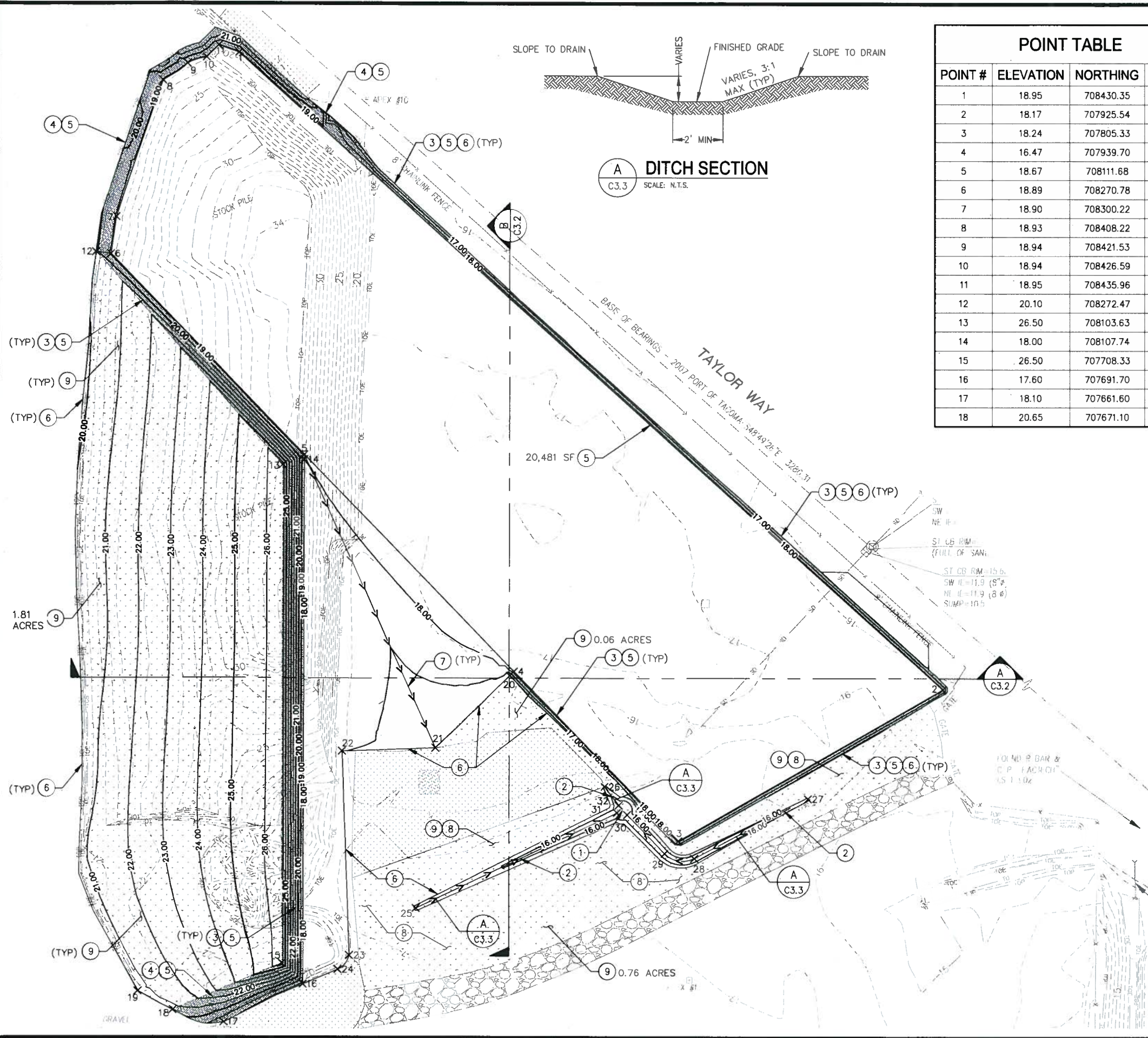

A DITCH SECTION
SCALE: N.T.S.

POINT #	ELEVATION	NORTHING	EASTING
1	18.95	708430.35	1176900.20
2	18.17	707925.54	1177459.82
3	18.24	707805.33	1177249.95
4	16.47	707939.70	1177119.65
5	18.67	708111.68	1176952.88
6	18.89	708270.78	1176798.61
7	18.90	708300.22	1176802.80
8	18.93	708408.22	1176839.50
9	18.94	708421.53	1176858.91
10	18.94	708426.59	1176874.11
11	18.95	708435.96	1176883.79
12	20.10	708272.47	1176786.73
13	26.50	708103.63	1176935.88
14	18.00	708107.74	1176952.88
15	26.50	707708.33	1176935.88
16	17.60	707691.70	1176952.88
17	18.10	707661.60	1176890.49
18	20.65	707671.10	1176849.88

POINT #	ELEVATION	NORTHING	EASTING
19	20.87	707685.97	1176822.10
20	16.48	707936.51	1177116.38
21	16.79	707878.99	1177057.05
22	17.34	707876.37	1176983.37
23	17.27	707714.57	1176989.29
24	17.40	707703.29	1176980.41
25	16.68	707751.86	1177041.78
26	17.15	707848.25	1177191.07
27	15.95	707838.71	1177352.64
28	15.44	707791.57	1177262.39
29	15.31	707795.35	1177238.73
30	15.10	707826.01	1177209.00
31	15.10	707827.46	1177200.99
32	15.10	707833.56	1177202.45

(X) BACKFILL AND GRADING NOTES:

1. NEW CATCH BASIN LOCATION. SEE SHEET C3.4 FOR INFORMATION.
2. PROVIDE DRAINAGE DITCH.
3. 2:1 SLOPE.
4. 2:1 MAX SLOPE.
5. PROVIDE SOIL STABILIZATION (EROSION CONTROL BLANKET AND HYDROSEEDING).
6. MATCH EXISTING GRADE.
7. FLOW LINE
8. GRADE FINAL SURFACE TO DRAIN TO DITCH.
9. PROVIDE HYDROSEEDING.

GENERAL BACKFILL AND GRADING NOTES:

1. USE MATERIAL FROM EXISTING SOIL STOCKPILE TO BACKFILL SPL AREA. PLACE BACKFILL IN MAXIMUM 6 TO 8 INCH LIFTS COMPACTED TO AT LEAST 90% OF MAXIMUM DRY DENSITY AS DETERMINED BY ASTM D1557 TEST PROCEDURE.
2. PLACE AND GRADE 3 INCH LAYER OF COMPACTED CRUSHED ASPHALT FROM ONSITE STOCKPILES AS FINAL SURFACING MATERIAL IN THE SPL AREA, EXCEPT FOR SOIL AREAS TO BE HYDROSEEDED.
3. GRADE FINAL SURFACES TO PROMOTE STORMWATER DRAINAGE TO DESIGNATED AREAS.



LANDAU ASSOCIATES
130 2nd AVENUE S.
EDMONDS, WA 98020
(425) 778-0907, FAX (425) 778-6409



CHECKED BY: DATE
DAKOTA CHAMBERLAIN MAY 17, 2013
DIRECTOR ENG. DATE: PROJ. ENGR DATE
MAY 17, 2013
PRINTED BY: JUDWIG MAY 17, 2013
PORT ADDRESS: ONE SITCUM PLAZA
TACOMA, WA 98401-1837

**FORMER KAISER FACILITY
INTERIM ACTION
SPL AREA
BACKFILL AND GRADING PLAN**

C3.3
SHEET 9 OF 15
CONT/CONS: 069646
PROJECT NO: 092837
PHASE: BID SET

THIS DRAWING IS THE PROPERTY OF THE PORT OF TACOMA AND SHALL NOT BE USED ON OTHER WORK, DISCLOSED, COPIED, IN WHOLE OR IN PART, WITHOUT WRITTEN PERMISSION

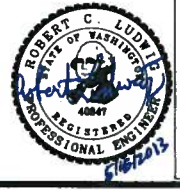
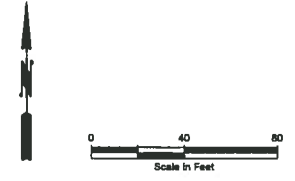

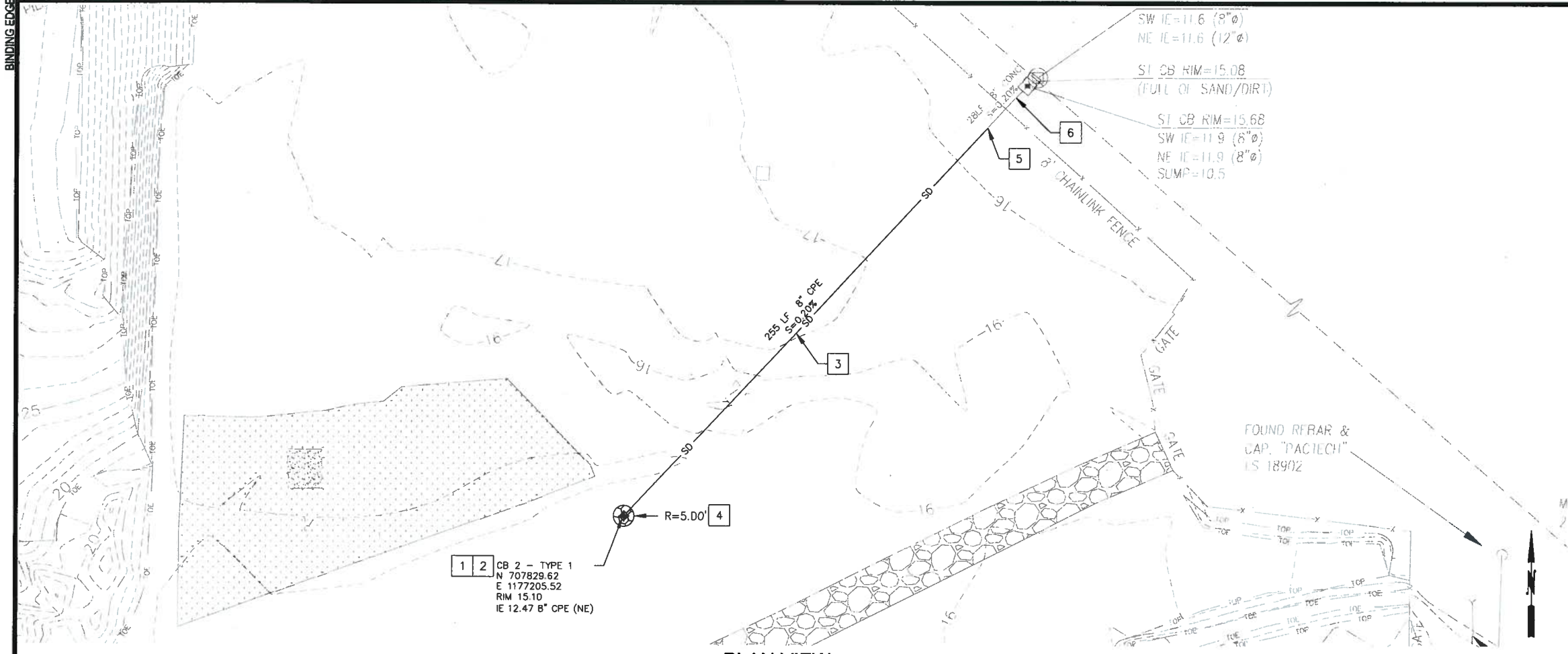

PLAN VIEW
SCALE: 1" = 30'

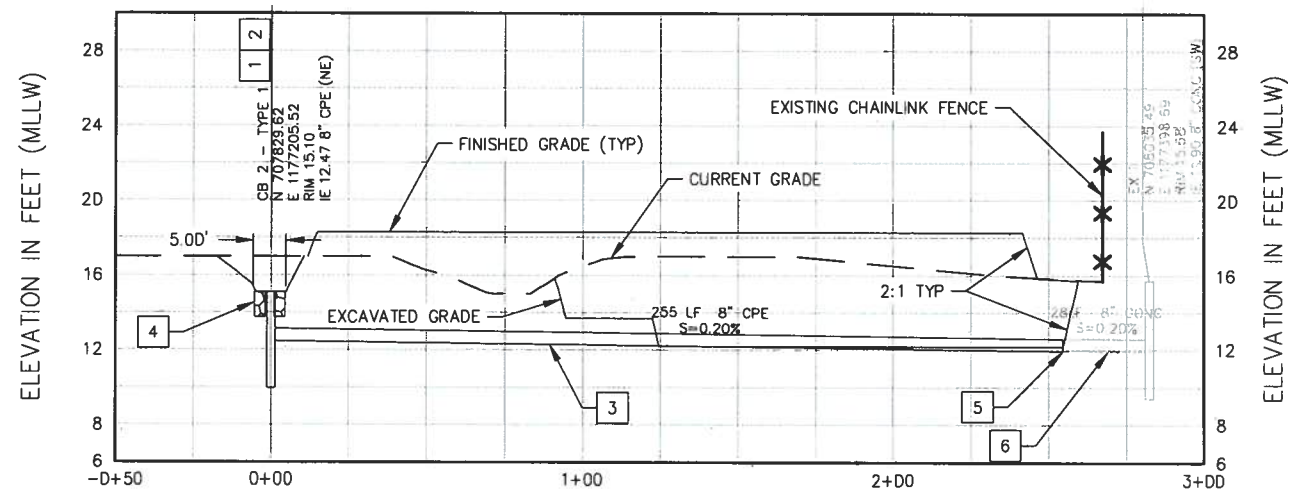

PROFILE VIEW
SCALE - H: 1" = 30'
V: 1" = 5'

X STORM DRAINAGE NOTES:

1. PROVIDE CATCH BASIN INLET PROTECTION. SEE SHEET C2.0 FOR MORE INFORMATION.
2. PROVIDE CATCH BASIN WITH GRATED LID.
3. PROVIDE CPE STORM DRAINAGE PIPE.
4. PROVIDE 1 FT THICK PAD OF QUARRY SPALLS AROUND CATCH BASIN.
5. CONNECT TO EXISTING STORM DRAIN PIPE.
6. EXISTING STORM DRAINAGE PIPE.



C3.4	FORMER KAISER FACILITY INTERIM ACTION SPL AREA STORM DRAINAGE PLAN	 Port of Tacoma 130 2nd Avenue S. Edmonds, WA 98020 (425) 778-9907, FAX (425) 778-6408	 Robert C. Ludvig Registered Professional Engineer License No. 48847	CHECKED BY: [Signature] DATE: MAY 22 2013 DIRECTOR ENG. DATE: [Signature] PROJ. ENGR DATE: May 17, 2013 PORT ADDRESS: ONE SITCUM PLAZA TACOMA, WA 98401-1837
SHEET 10 OF 15	PROJECT NO: 092837	PHASE: BID SET	MARK: [] REVISION: [] BY: [] APPR: [] DATE: []	THIS DRAWING IS THE PROPERTY OF THE PORT OF TACOMA AND SHALL NOT BE USED ON OTHER WORK, DISCLOSED, COPIED, IN WHOLE OR IN PART, WITHOUT WRITTEN PERMISSION

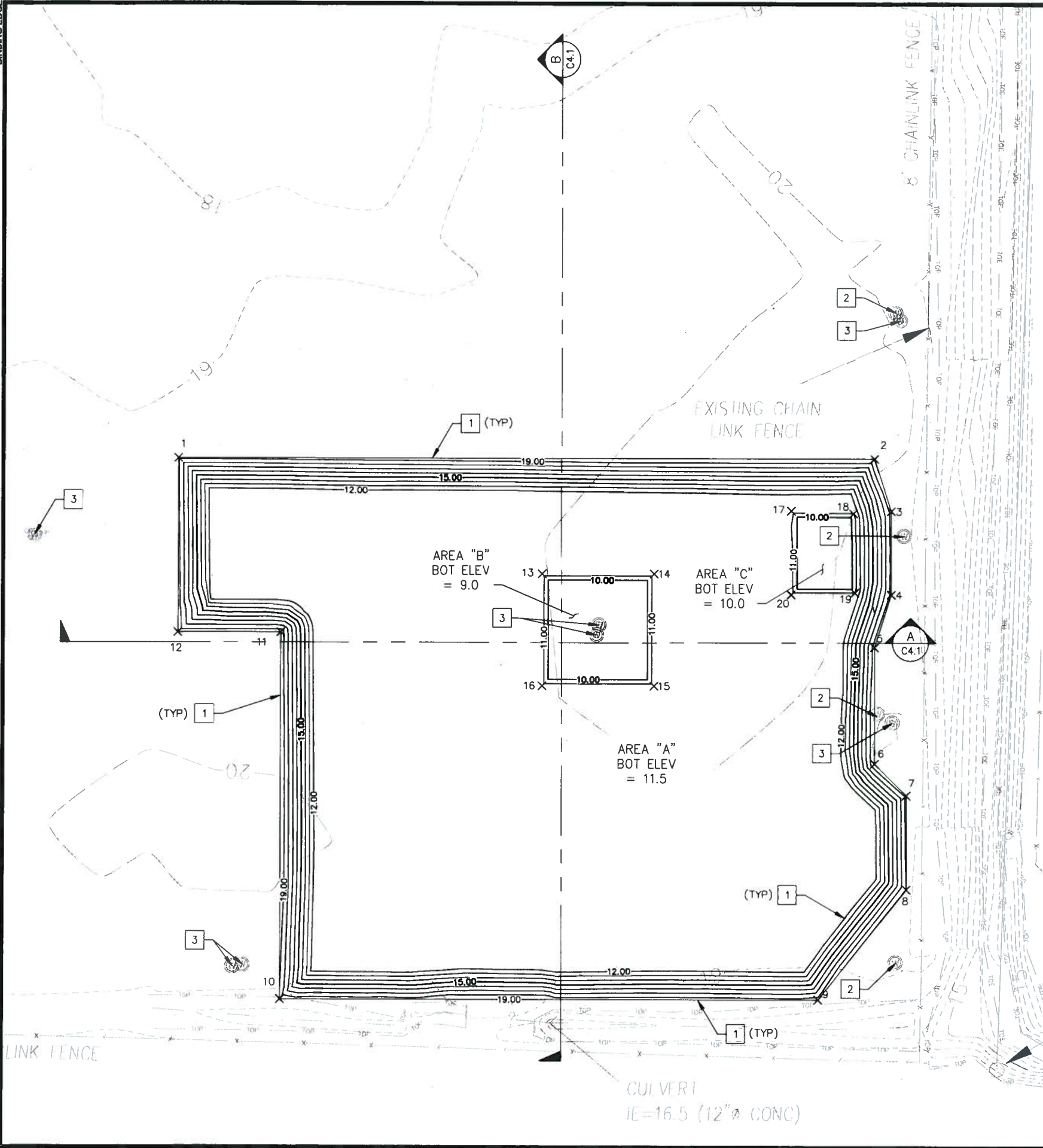

POINT TABLE		
POINT #	NORTHING	EASTING
1	707379.81	1177308.75
2	707379.81	1177558.75
3	707361.00	1177564.77
4	707331.00	1177564.77
5	707312.19	1177558.75
6	707270.37	1177558.75
7	707258.99	1177570.13
8	707225.27	1177570.13
9	707185.79	1177538.43
10	707185.79	1177345.77
11	707317.32	1177345.77
12	707317.32	1177308.75
13	707338.33	1177439.36
14	707338.33	1177479.36
15	707298.33	1177479.36
16	707298.33	1177439.36
17	707361.00	1177528.75
18	707360.25	1177551.22
19	707331.75	1177551.71
20	707331.00	1177528.75

x ROD MILL CLOSED LANDFILL EXCAVATION NOTES:

- ASSUMED BOUNDARY OF EXCAVATION WITH 1.5H:1V SIDE SLOPES AND UP TO 1 FOOT OF SOIL REMOVED BELOW CURRENTLY IDENTIFIED ROD MILL LANDFILL SOIL AND DEBRIS MATERIAL. ACTUAL EXTENT AND DEPTH OF LANDFILL SOIL AND DEBRIS TO BE REMOVED FOR DISPOSAL TO BE BASED ON DETERMINATIONS BY THE PORT'S REPRESENTATIVE AND LABORATORY RESULTS OBTAINED DURING CONTRACTOR'S EXCAVATION ACTIVITIES.
- PROTECT EXISTING GROUNDWATER MONITORING WELLS FROM DAMAGE DURING ROD MILL LANDFILL EXCAVATION AND BACKFILLING ACTIVITIES. DAMAGED/DESTROYED WELLS TO BE REPAIRED OR REPLACED AT CONTRACTORS EXPENSE.
- VERIFY WITH THE PORT THAT THE GROUNDWATER MONITORING WELLS ARE DECOMMISSIONED (BY OTHERS) PRIOR TO DEMOLITION OF ANY REMAINING WELL MONUMENTS, BOLLARDS, AND CONCRETE SEALS.

GENERAL ROD MILL CLOSED LANDFILL EXCAVATION NOTES:

- ANTICIPATE THAT OVERSIZED DEBRIS IS PRESENT THAT WILL NEED TO BE EXCAVATED AND SIZE REDUCED AS REQUIRED FOR LOADING AND OFFSITE DISPOSAL.
- PORTIONS OF THE LANDFILL EXCAVATION ARE ANTICIPATED TO EXTEND BELOW GROUNDWATER LEVEL. UNLESS OTHERWISE APPROVED BY THE PORT, CONTRACTOR SHALL FIRST EXCAVATE SURFICIAL MATERIALS TO A DEPTH THAT LEAVES SUFFICIENT MATERIAL ABOVE GROUNDWATER LEVEL TO SUPPORT CONSTRUCTION EQUIPMENT BEFORE EXTENDING FINAL EXCAVATIONS BELOW GROUNDWATER.
- SATURATED SOIL AND DEBRIS EXCAVATED BELOW GROUNDWATER LEVEL SHALL BE PLACED IN TEMPORARY STOCKPILES WITHIN THE LANDFILL EXCAVATION AREA WHERE EXCESS WATER IS ALLOWED TO DRAIN AND WETTER MATERIAL CAN BE MIXED WITH DRIER MATERIALS PRIOR TO LOADING FOR OFFSITE DISPOSAL.
- ANTICIPATE THAT PETROLEUM HYDROCARBON PRODUCT AND/OR SHEEN WILL BE PRESENT AT GROUNDWATER LEVEL, AND SKIM/VACUUM OFF FLOATING PETROLEUM HYDROCARBON MATERIAL PRIOR TO PLACING EXCAVATION BACKFILL MATERIALS.
- UNLESS OTHERWISE DIRECTED BY THE PORT, CONSTRUCTION STORMWATER SHALL BE MANAGED BY EVAPORATION AND/OR INFILTRATION AT LOCATIONS APPROVED BY THE PORT.
- OBTAIN CONFIRMATION FROM THE PORT THAT CONTAMINATED MATERIALS HAVE BEEN ADEQUATELY REMOVED IN EACH AREA PRIOR TO START OF BACKFILLING IN THAT AREA.



LANDAU ASSOCIATES
 130 2nd AVENUE S.
 EDMONDS, WA 98020
 (425) 778-0907, FAX (425) 778-6409



CHECKED BY: DATE
 PROJECTED BY: DATE
 DIRECTOR ENG. DATE: May 22, 2013
 PRINTED BY: rldwig, May 17, 2013
 PORT ADDRESS: ONE SITCUM PLAZA
 TACOMA, WA 98401-1837

**FORMER KAISER FACILITY
 INTERIM ACTION
 ROD MILL CLOSED LANDFILL AREA**

C4.0
 SHEET 11 OF 15
 CONT/CONS: 069646
 PROJECT NO: 092837
 PHASE: BID SET



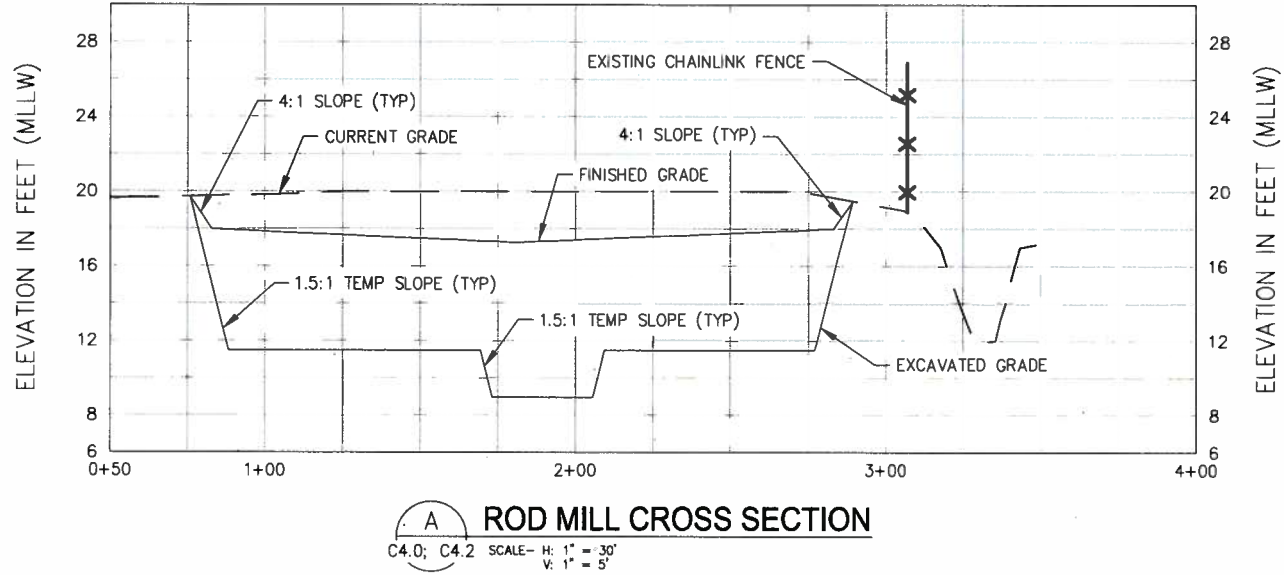
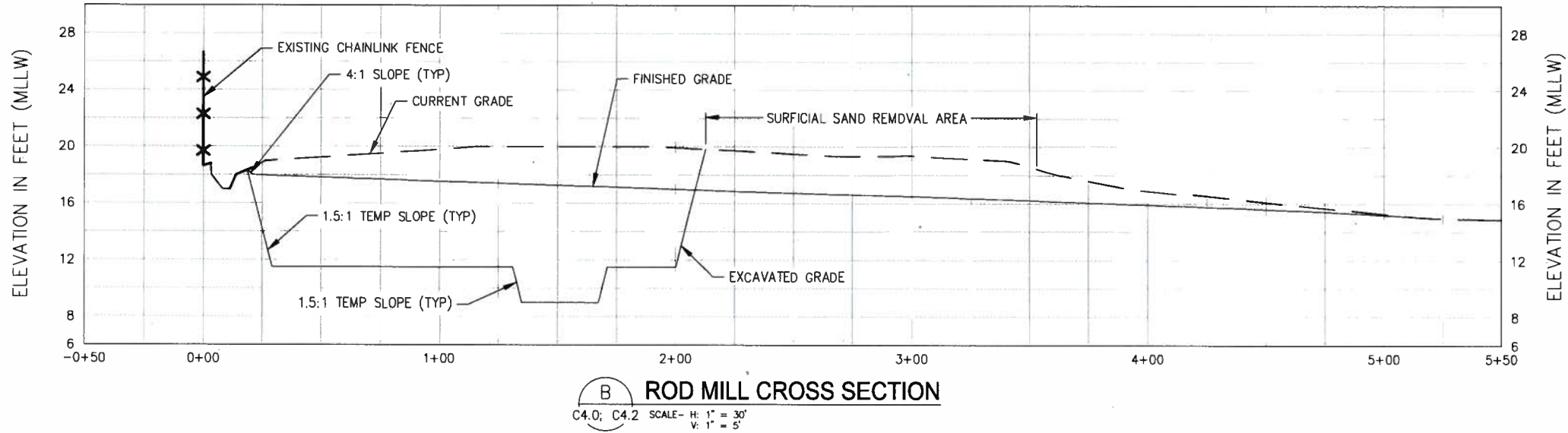

C4.1
 SHEET 12 OF 15
 CONT/CONS: 069646
 PROJECT NO: 092837
 PHASE: BID SET

**FORMER KAISER FACILITY
 INTERIM ACTION
 ROD MILL CLOSED LANDFILL AREA
 EXCAVATION SECTIONS**

TOWNSHIP: 21 NORTH RANGE: 3 EAST SECTION: SW 1/4-36
 DAT-HRZ: WA83-SF VERT: MLLW 19.39' @ Tide 22 1933
 PARCEL: 77 DRAWING SCALE: AS NOTED

APPROVED: *[Signature]*
 BARBARA CHAMBERLAN
 MAY 17 2013
 DIRECTOR ENGR. DATE
 PRINTED BY: cludwig, May 17, 2013

CHECKED BY: DATE
 PROJ. ENGR DATE
 PORT ADDRESS: ONE SITCUM PLAZA
 TACOMA, WA 98401-1837



LA LANDAU ASSOCIATES
 130 2ND AVENUE S.
 EDMONDS, WA 98020
 (425) 778-0907, FAX (425) 778-6409

MARK: REVISION: BY: DATE:
 APPR: DATE:



BINDING EDGE

PORT OF TACOMA FILE: V:\118003\010.0408\d Se1092837-C4.2

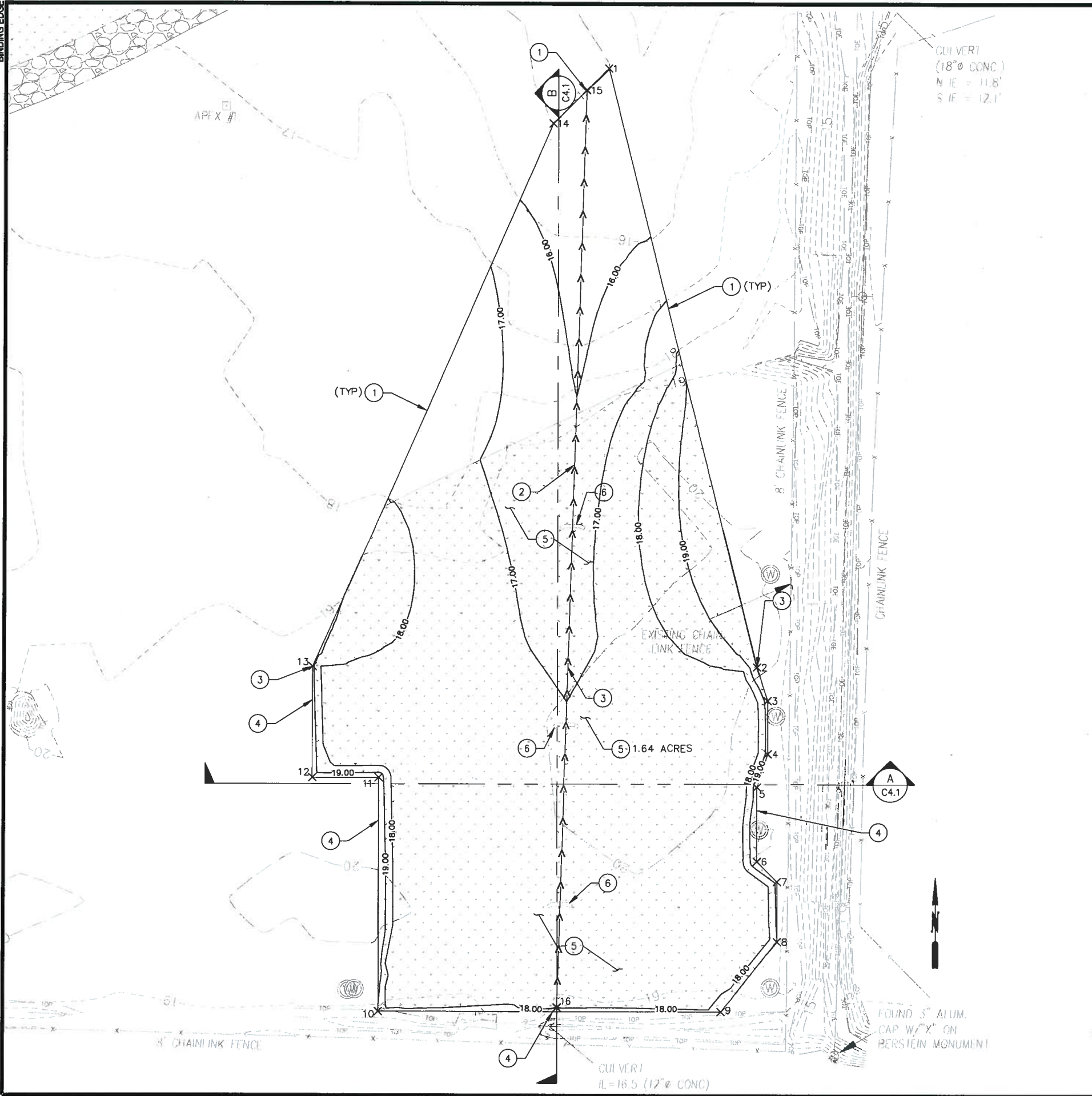

POINT TABLE			
POINT #	ELEV	NORTHING	EASTING
1	15.00	707717.02	1177474.90
2	20.11	707379.81	1177558.75
3	19.69	707361.00	1177564.77
4	19.42	707331.00	1177564.77
5	19.55	707312.19	1177558.75
6	19.92	707270.37	1177558.75
7	19.51	707258.99	1177570.13
8	19.17	707225.27	1177570.13
9	18.62	707185.79	1177538.43
10	18.59	707185.79	1177345.77
11	19.73	707317.32	1177345.77
12	19.74	707317.32	1177308.75
13	19.23	707379.81	1177308.75
14	15.00	707685.92	1177443.55
15	15.00	707704.64	1177462.41
16	18.00	707188.12	1177446.27

(X) BACKFILL AND GRADING NOTES:

1. MATCH INTO EXISTING AND/OR MODIFIED GRADES.
2. FLOW LINE SLOPE 0.50% MINIMUM.
3. NORTHERN EDGE OF LANDFILL EXCAVATION AREA AND SOUTHERN EDGE OF SURFICIAL SAND REMOVAL AREA. SURFICIAL SAND TO BE REMOVED AND USED AS LANDFILL EXCAVATION BACKFILL MATERIAL.
4. 4:1 SIDE SLOPES AROUND PERIMETER OF ROD MILL LANDFILL EXCAVATION AREA.
5. PROVIDE HYDROSEEDING.
6. PROVIDE QUARRY SPALL CHECK DAMS ACROSS FLOW LINE, MIN 15 FT WIDE AND 1 FT HIGH

GENERAL BACKFILL AND GRADING NOTES:

1. SKIM/VACUUM OFF ANY FLOATING PETROLEUM HYDROCARBON PRODUCT/SHEEN ON GROUNDWATER EXPOSED IN DEEPER LANDFILL EXCAVATIONS PRIOR TO PLACING QUARRY SPALLS TO RAISE THE BACKFILL SURFACE UP ABOVE GROUNDWATER LEVEL AND CREATE A STABLE BASE FOR OVERLYING FILL MATERIALS.
2. USE SURFICIAL SAND REMOVED FROM ADJACENT CUT AREA TO THE NORTH, MATERIAL FROM THE EXISTING SOIL STOCKPILE, AND RUBBLIZED CONCRETE/ASPHALT TO BACKFILL THE ROD MILL LANDFILL EXCAVATION. PLACE BACKFILL IN MAXIMUM 6 TO 8 INCH LIFTS COMPACTED TO AT LEAST 90% OF MAXIMUM DRY DENSITY AS DETERMINED BY THE ASTM D1557 TEST PROCEDURE. RUBBLIZED CONCRETE/ASPHALT SHALL BE PLACED AT LEAST 3 FEET ABOVE GROUNDWATER LEVEL AND INTERMIXED WITH ONSITE SOIL BACKFILL
3. GRADE FINAL SURFACES TO PROMOTE STORMWATER DRAINAGE.

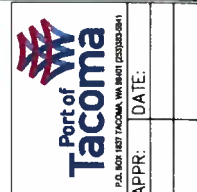

LA LINDAU ASSOCIATES
 130 2nd AVENUE S.
 EDMONDS, WA 98020
 (425) 778-0907, FAX (425) 778-6409



APPROVED: *[Signature]*
 DAVID A. FISCHER
 MAY 11, 2013
 DIRECTOR ENG. DATE
 PRINTED BY: rhdwlg May 17, 2013
 PORT ADDRESS: ONE SITCOM PLAZA
 TACOMA, WA 98401-1837

FORMER KAISER FACILITY
INTERIM ACTION
 ROD MILL CLOSED LANDFILL AREA
 BACKFILL AND GRADING PLAN
 TOWNSHIP: 21 NORTH | RANGE: 3 EAST | SECTION: SW 1/4-36
 DAT-HRZ: WA83-SF | VERT: MLLW 19.39' @ Tide 22 1933
 PARCEL: 77 | DRAWING SCALE: AS NOTED

C4.2
 SHEET 13 OF 15
 CONT/CONS: 069646
 PROJECT NO: 092837
 PHASE: BID SET



THIS DRAWING IS THE PROPERTY OF THE PORT OF TACOMA AND SHALL NOT BE USED ON OTHER WORK, DISCLOSED, COPIED, IN WHOLE OR IN PART, WITHOUT WRITTEN PERMISSION

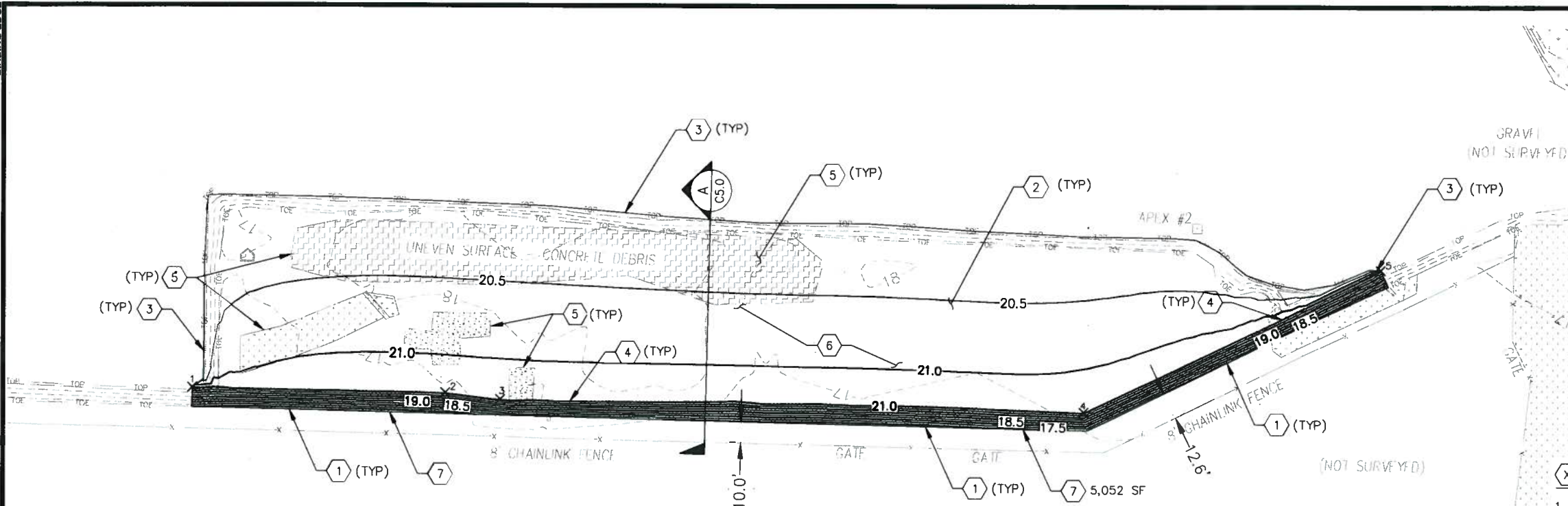

PLAN VIEW
SCALE: 1" = 30'

POINT TABLE			
POINT #	ELEV	NORTHING	EASTING
1	21.25	707542.50	1176182.07
2	21.25	707540.35	1176300.75
3	21.25	707537.19	1176326.63
4	21.25	707531.71	1176600.81
5	21.25	707598.39	1176740.29

(X) BACKFILL AND GRADING NOTES:

1. FILL SLOPE IS 2:1.
2. SLOPE FINAL FILL TO MATCH EXISTING SLOPE TO WEST.
3. TIE INTO EXISTING EDGE OF FILL.
4. TOP ELEVATION ALONG EDGE OF FILL IS 21.25 FT.
5. EXISTING CONCRETE, ASPHALT, AND OTHER DEBRIS TO BE BURIED.
6. EXISTING VEGETATION SHALL BE KNOCKED DOWN AND BURIED BELOW FILL.
7. PROVIDE SOIL STABILIZATION (EROSION CONTROL BLANKET AND HYDROSEEDING).

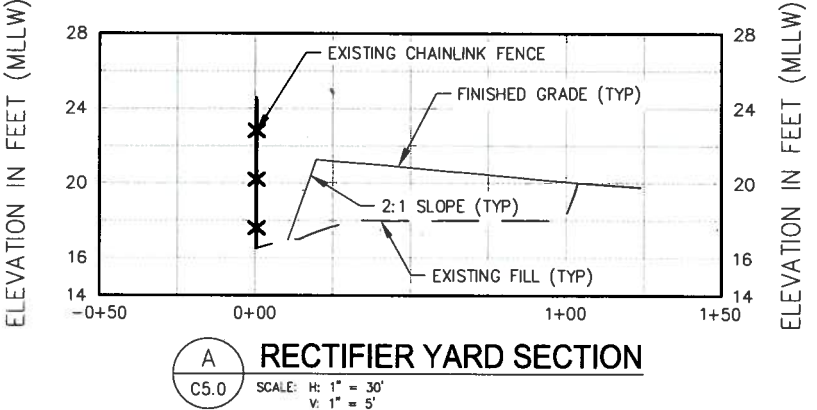

A RECTIFIER YARD SECTION
SCALE: H: 1" = 30'
V: 1" = 5'

GENERAL BACKFILL AND GRADING NOTES:

1. USE MATERIAL FROM EXISTING SOIL STOCKPILES AND RUBBLIZED CONCRETE AND ASPHALT TO BACKFILL THE FORMER RECTIFIER YARD AREA. PLACE BACKFILL IN MAXIMUM 6 TO 8 INCH LIFTS COMPACTED TO AT LEAST 90% OF MAXIMUM DRY DENSITY AS DETERMINED BY THE ASTM D1557 TEST PROCEDURE.
2. PLACE A 3 INCH LAYER OF COMPACTED CRUSHED ASPHALT FROM ONSITE STOCKPILES AS FINAL SURFACING MATERIAL IN THE RECTIFIER YARD FILL AREA.
3. GRADE FINAL SURFACES TO PROMOTE STORMWATER DRAINAGE NORTH TO EXISTING FILLED AREAS.



LANDAU ASSOCIATES
130 2ND AVENUE S.
EDMONDS, WA 98020
(425) 778-0907, FAX (425) 778-9409



APPROVED: JUDITH CHAMBERLAIN
MAY 27 2013
DIRECTOR ENG. DATE
PROJECTED BY: JUDITH CHAMBERLAIN
MAY 17, 2013
PORT ADDRESS: ONE SITCUM PLAZA
TACOMA, WA 98401-1837

FORMER KAISER FACILITY
INTERIM ACTION
RECTIFIER YARD AREA
BACKFILL AND GRADING PLAN
TOWNSHIP: 21 NORTH RANGE: 3 EAST SECTION: SW 1/4-36
DATE-HRZ: WAB3-SF VERT: MLLW 19.39' @ Tide 22 1933
DRAWING SCALE: AS NOTED
PARCEL: 77

C5.0
SHEET 14 OF 15
CONT/CONS: 069646
PROJECT NO: 092837
PHASE: BID SET



THIS DRAWING IS THE PROPERTY OF THE PORT OF TACOMA AND SHALL NOT BE USED ON OTHER WORK, DISCLOSED, COPIED, IN WHOLE OR IN PART, WITHOUT WRITTEN PERMISSION

KAISER INTERIM ACTION DESIGN TOPOGRAPHIC SURVEY

SITUATED IN A PORTION OF THE SOUTHEAST QUARTER OF SECTION 35,
TOWNSHIP 21 NORTH, RANGE 3 EAST, PIERCE COUNTY, WASHINGTON

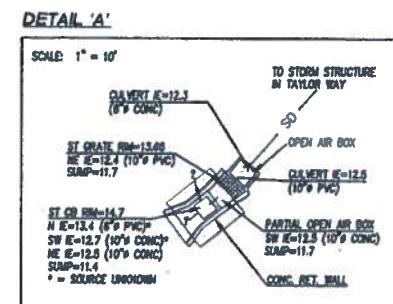

P.O.T. CONTROL

POINT	NORTHING	EASTING	ELEVATION
135	708889.8110	1178944.7480	18.18
175	708949.4850	1178475.6970	18.15

ST. CRK RM=15.13
SW E=11.8 (8'9")
NE E=11.8 (12'9")

ST. CRK RM=15.08
(FULL OF SAND/DIRT)

ST. CRK RM=15.88
SW E=11.8 (8'9")
NE E=11.9 (8'9")
SUMP=10.5

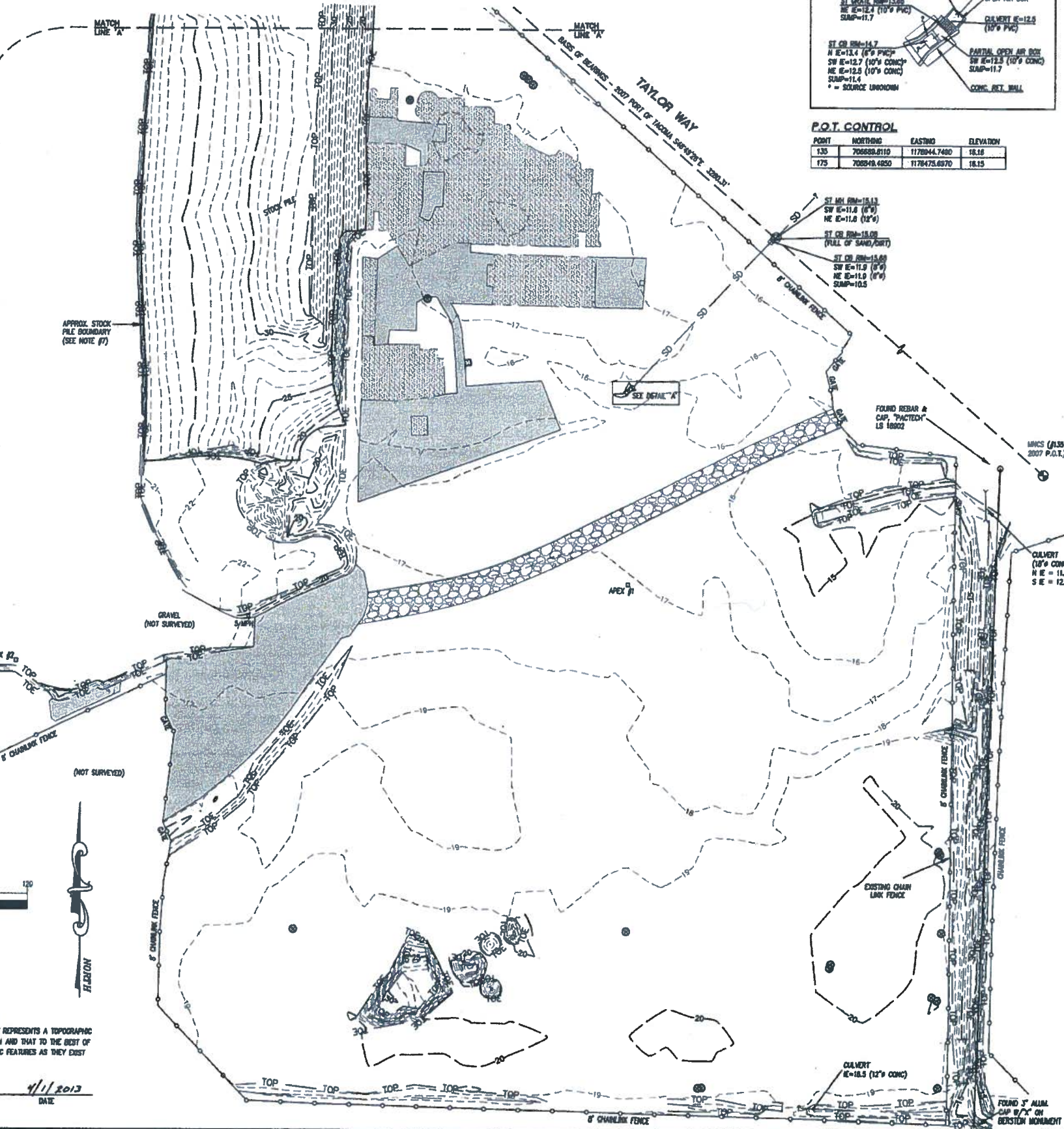
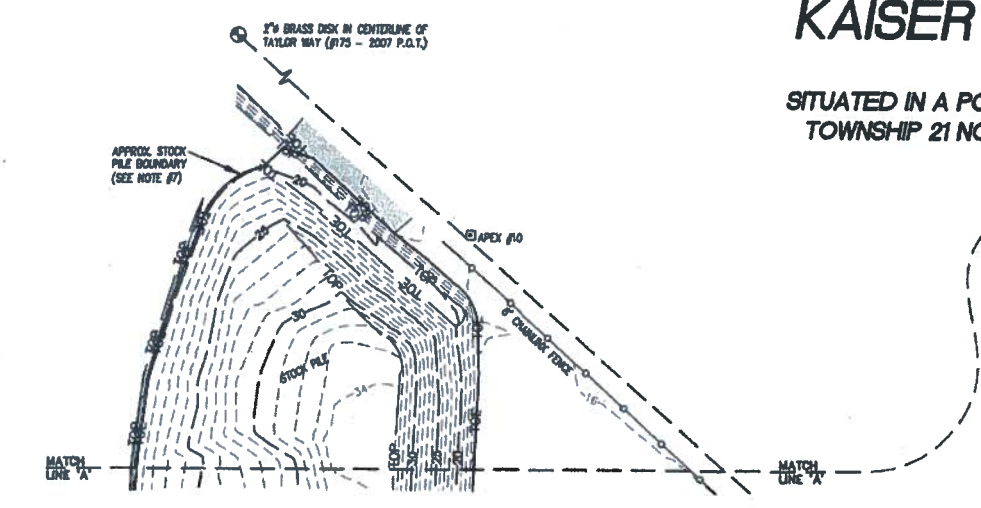

HORIZONTAL DATUM

WASHINGTON STATE PLANE COORDINATE SYSTEM, SOUTH ZONE, NAD 83/07.
AS DERIVED FROM GLOBAL POSITIONING SYSTEM (GPS) TIES TO PORT OF TACOMA SURVEY CONTROL MONUMENTS AS SHOWN ON PORT OF TACOMA (POT) 2007 SURVEY CONTROL MAP TITLED "TALAR-HYLEBOS PENINSULA SURVEY CONTROL MAP", PREPARED BY PARAMETRIX, DATED JANUARY 7, 2008.

POT MONUMENT #135 N 708889.81, E 1178944.75
POT MONUMENT #175 N 708949.485, E 1178475.697
HELD INVERSE BEARING BETWEEN #179 AND #135, BEING SOUTH 48°49'28" EAST (AS SHOWN HEREON).

NOTE:
1. ALL DISTANCES SHOWN ARE GROUND VALUES.

VERTICAL DATUM

PORT OF TACOMA - MLLW
BENCHMARK: POT MONUMENT #175
2" BRASS DISK ON THE SW SIDE OF TAYLOR WAY
ELEV: 18.15'
(NOTE: SUBTRACT 0.17' TO CONVERT TO CITY OF TACOMA (NGVD '29) VERTICAL DATUM)

METHODS AND EQUIPMENT

SURVEY PERFORMED WITH A 1" TOTAL STATION, USING TRAVERSE AND RADIAL SURVEY METHODS, AND SUPPLEMENTED USING A TOPCON HYPERLITE GPS RECEIVER UTILIZING RTK METHODS AND THE WASHINGTON STATE REFERENCE NETWORK. SURVEY MEETS OR EXCEEDS ACCURACY REQUIREMENTS CONTAINED IN W.A.C. 332.130.080.

SURVEYOR'S NOTE

1. DATA FOR THIS SURVEY WAS GATHERED BY FIELD TRAVERSE UTILIZING ELECTRONIC DATA COLLECTION ON 01-16-13.
2. CONTOUR INTERVALS ARE ONE FOOT AND ARE COMPUTER GENERATED FROM GROUND FIELD TOPOGRAPHY GATHERED FOR THIS SURVEY UTILIZING ELECTRONIC DATA COLLECTION.
3. APEX ENGINEERING PLLC ASSUMES NO LIABILITY FOR ANY SUBSURFACE CONDITIONS OR FEATURES THAT MAY EXIST THAT ARE UNDETECTABLE AND/OR NOT VISIBLE.
4. PURPOSE OF SURVEY: TO PROVIDE A TOPOGRAPHIC BASE MAP OF THE EXISTING CONDITIONS ON PROJECT SITE FOR PLANNING, DESIGN, AND CONSTRUCTION. THIS IS NOT A BOUNDARY SURVEY.
5. UTILITIES OTHER THAN SHOWN MAY EXIST ON THE SITE. ONLY THOSE UTILITIES VISIBLE AT GROUND SURFACE ARE SHOWN HEREON. THE SURVEYOR DOES NOT WARRANT THAT THE UNDERGROUND UTILITY LINES (IF ANY) SHOWN HEREON ARE IN THE EXACT LOCATION INDICATED. THE SURVEYOR DOES CERTIFY THAT THEY ARE SHOWN AS ACCURATELY AS POSSIBLE FROM FIELD SURVEY INFORMATION.
6. THE STORM AND SANITARY SEWER LINES (IF ANY) SHOWN HEREON ARE AN APPROXIMATE LOCATION AND DIRECTION AS SHOWN ON PORT OF TACOMA MAPS.
7. VOLUME OF THE STOCK PILE IS APPROXIMATELY 28,100 CUBIC YARDS. THE VOLUME IS BASED ON AN ASSUMPTION THAT THE GROUND UPON WHICH THE PILE WAS PLACED WAS A PLANE BASED ON THE PERIMETER SHOTS AT THE BASE OF THE PILE.

LEGEND

- EXISTING SURVEY MONUMENT
- EXISTING SURVEY MONUMENT - SECONDARY
- SURVEY CONTROL POINT
- STORMWATER CATCH BASIN
- STORMWATER MANHOLE
- STORMWATER CULVERT
- MONITORING WELL
- ▲ SIGN
- ASPHALT
- CONCRETE
- GRAVEL
- SD STORM DRAIN LINE
- CL CHAIN LINK FENCE
- TOP TOP OF SLOPE
- TOE TOE OF SLOPE
- MAJOR CONTOUR
- MINOR CONTOUR

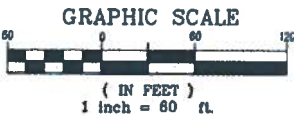
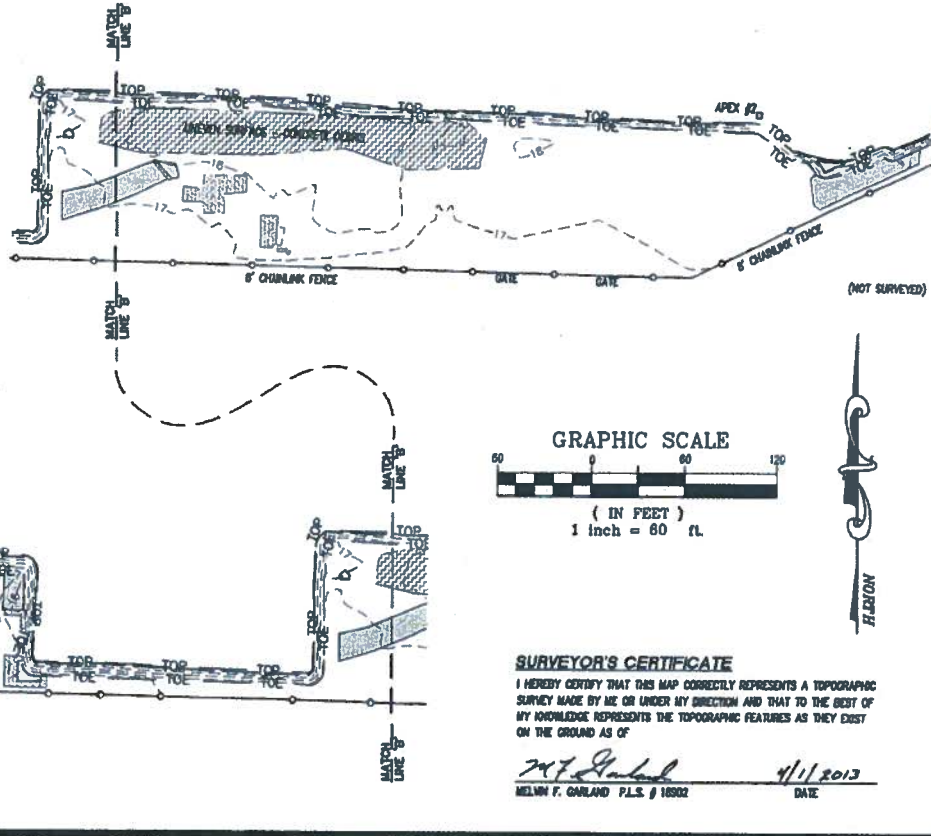

SURVEYOR'S CERTIFICATE
I HEREBY CERTIFY THAT THIS MAP CORRECTLY REPRESENTS A TOPOGRAPHIC SURVEY MADE BY ME OR UNDER MY DIRECTION AND THAT TO THE BEST OF MY KNOWLEDGE REPRESENTS THE TOPOGRAPHIC FEATURES AS THEY EXIST ON THE GROUND AS OF
Melvin F. Garland 4/11/2013
MELVIN F. GARLAND P.L.S. # 18992 DATE

Port of Tacoma
2007 SURVEY CONTROL MAP TITLED "TALAR-HYLEBOS PENINSULA SURVEY CONTROL MAP" PREPARED BY PARAMETRIX, DATED JANUARY 7, 2008.

Apex Engineering?

APPROVED: *[Signature]* 4/11/2013
DIRECTOR ENG. DATE: 5/22/13
PRINTED BY: smovok Apr 01, 2013
PORT ADDRESS: ONE SITCOM PLAZA TACOMA, WA 98401-1837

**KAISER INTERIM ACTION DESIGN
TOPOGRAPHIC SURVEY
3400 TAYLOR WAY
TACOMA, WA**

TOWNSHIP: 21 NORTH RANGE: 3 EAST SECTION: 35
DAT-HRZ: WA83-SF VERT: MLLW (SEE NOTES) DRAWING SCALE: 1" = 60'
PARCEL: []

CONTRACT 068411
PROJECT NO. 092637
SHEET 1 OF 1
CONT./CONS.
M. ID.:
PHASE: SURVEY SET

CHECKED BY: DATE
PROJ. ENGR. DATE
DATE: APR 01, 2013
TACOMA, WA 98401-1837

MARK: REVISION: BY: DATE

THIS DRAWING IS THE PROPERTY OF THE PORT OF TACOMA AND SHALL NOT BE USED ON OTHER WORK. DISCLOSED, COPIED, IN WHOLE OR IN PART, WITHOUT WRITTEN PERMISSION

As-Built Drawings

A PORTION OF THE SW 1/4 OF SECTION 36, TOWNSHIP 21 NORTH, RANGE 3 EAST, W.M.

PORT OF TACOMA

FORMER KAISER FACILITY INTERIM ACTION

BEYLER CONSULTING SURVEY CONTROL MAP

HORIZONTAL DATUM

WASHINGTON STATE PLANE COORDINATE SYSTEM,
SOUTH ZONE, NAD 83/07.

POT MONUMENT #135 N 706689.81, E 1178944.75
POT MONUMENT #175 N 708849.50, E 1176475.70

BASIS OF BEARING: SOUTH 48°49'26" EAST;
THE MONUMENT LINE OF TAYLOR WAY FROM
POT MONUMENT #175 TO POT MONUMENT #135

VERTICAL DATUM

PORT OF TACOMA - MLLW
BENCHMARK: POT MONUMENT #175
2" BRASS DISK, 13.5' WEST OF WEST CURB LINE OF
TAYLOR WAY

ELEV: 16.15'

[NOTE: SUBTRACT 6.17' TO CONVERT TO CITY OF
TACOMA (NGVD '29) VERTICAL DATUM]

METHODS AND EQUIPMENT

NIKON DTM 410 TOTAL STATION. STANDARD FIELD
TRAVERSE METHODS FOR CONTROL AND STAKING.

CONTROL POINT TABLE

BC CP#10: FOUND HUB & TACK; APEX#10
N: 708393.94
E: 1177001043
ELV: 16.15





BC CP#13: FOUND HUB & TACK; APEX#1
N: 707695.06
E: 1177258.71
ELV: 17.10

BC CP#14: FOUND HUB & TACK; APEX#2
N: 707617.98
E: 1176654.11
ELV: 20.55

BC CP#51: SET HUB & TACK
N: 707932.33
E: 1177586.57
ELV: 16.59

TBM: CENTER RIM OF STORM DRAIN MANHOLE
N: 708039.39
E: 1177403.70
ELV: 15.13

LEGEND

-  EXISTING SURVEY MONUMENT AS NOTED
-  SURVEY CONTROL POINT AS NOTED
-  MAJOR CONTOUR
-  MINOR CONTOUR

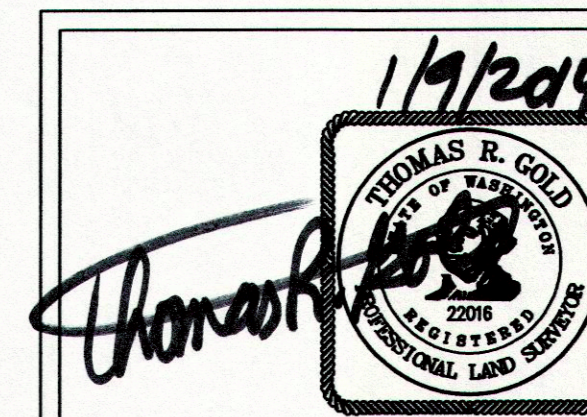
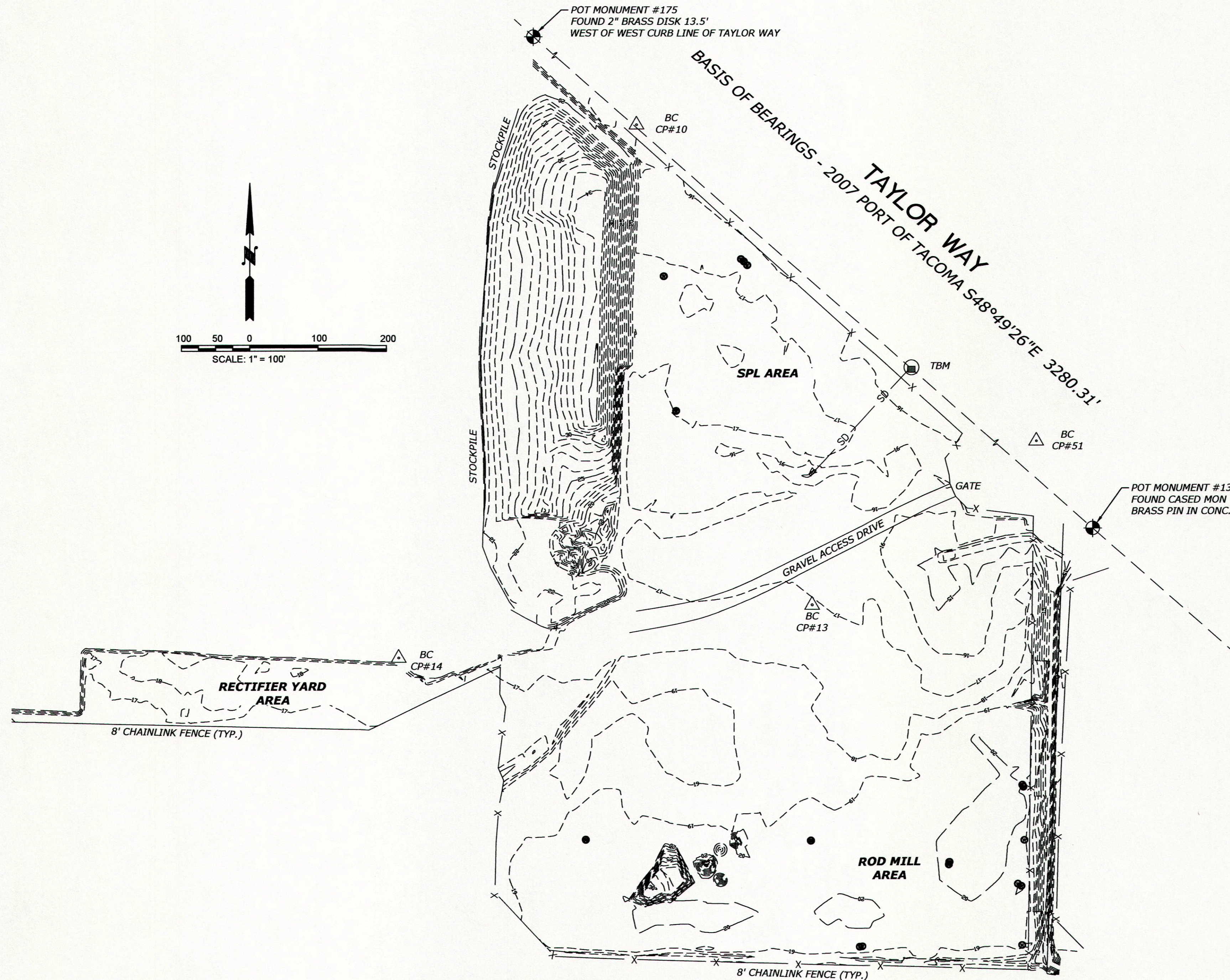
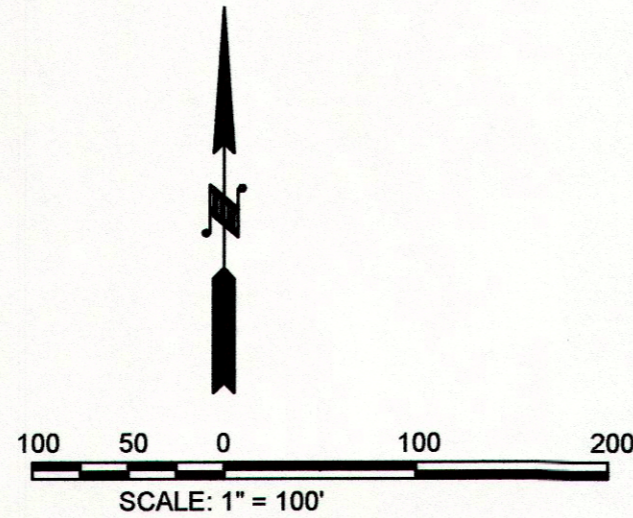

AS-BUILT CERTIFICATION
I HEREBY DECLARE THAT THE HORIZONTAL AND
VERTICAL ELEVATIONS OF THE GRADING AND
EXCAVATION AREA SHOWN HEREON IS THE RESULT
OF A FIELD SURVEY PERFORMED BY ME OR UNDER MY
DIRECTION

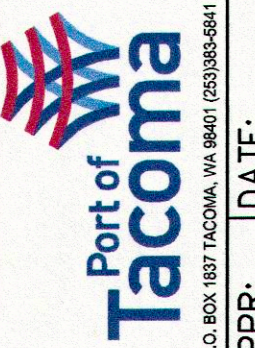

OFFICE
10314 100th St. SW
Lakewood, WA 98498
PHONE: 253-301-4157
FAX: 253-336-3950
CIVIL ENGINEERING | LAND SURVEYING | LAND PLANNING
PROJECT MANAGEMENT | PERMIT EXPEDITING | FEASIBILITY

BEYLER
CONSULTING

MARK: REVISION:
BY: DATE:
APPR: DATE:

APPROVED:
CHECKED BY: DATE:
DIRECTOR: ENG. DATE:
PRINTED BY: drew Jan 09, 2014
PORT ADDRESS: DNE SITCUM PLAZA
TACOMA, WA 98401-1837

FORMER KAISER FACILITY
INTERIM ACTION
PROJECT SITE
SURVEY CONTROL MAP

SC1.0
SHEET 1 OF 5
CONT/CONS: 069646
PROJECT NO: 092837
PHASE: AS-BUILT SET

TOWNSHIP: 21 NORTH | RANGE: 3 EAST | SECTION: SW 1/4-36
DAT-HRZ: WA83-SF | VERT: MLLW 19.39' @ Tide 22 1933
PARCEL: 77 | DRAWING SCALE: AS NOTED

THIS DRAWING IS THE PROPERTY OF THE PORT OF TACOMA AND SHALL NOT BE USED ON OTHER WORK, DISCLOSED, COPIED, IN WHOLE OR IN PART, WITHOUT WRITTEN PERMISSION

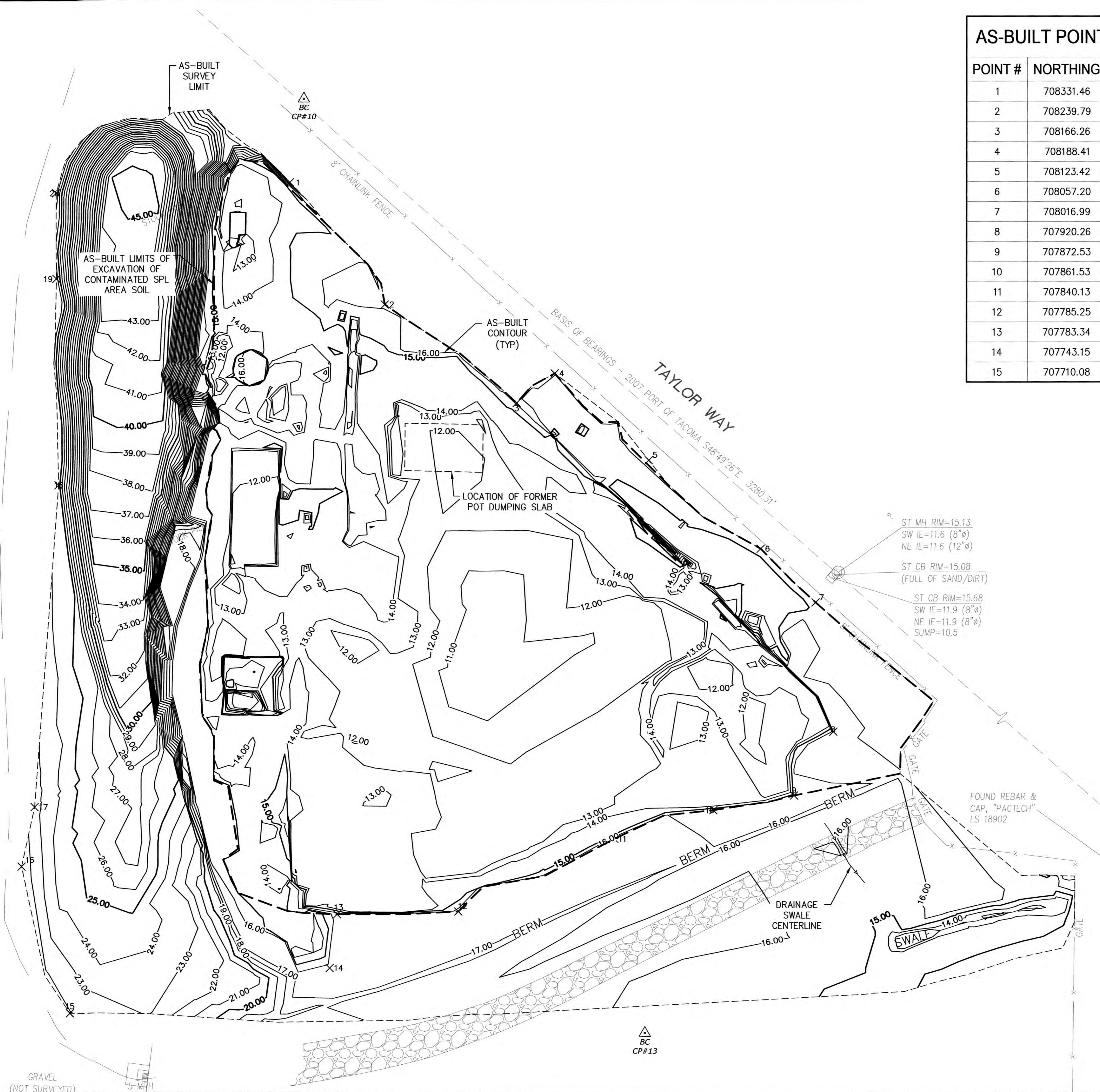

AS-BUILT POINT TABLE

POINT #	NORTHING	EASTING
1	708331.46	1176990.97
2	708239.79	1177062.46
3	708166.26	1177161.81
4	708188.41	1177190.37
5	708123.42	1177261.12
6	708057.20	1177345.42
7	708016.99	1177386.72
8	707920.26	1177400.17
9	707872.53	1177370.75
10	707861.53	1177310.04
11	707840.13	1177235.61
12	707785.25	1177118.28
13	707783.34	1177027.07
14	707743.15	1177021.54
15	707710.08	1176825.99

AS-BUILT POINT TABLE

POINT #	NORTHING	EASTING
16	707819.69	1176789.45
17	707864.21	1176799.20
18	708105.32	1176816.84
19	708259.99	1176815.16
20	708324.18	1176814.94

AS-BUILT VOLUMES

SPL CONTAMINATED SOIL EXCAVATION	28,761 CY
INITIAL OVERBURDEN REMOVED	340 CY
TOTAL CUT FROM SPL STOCKPILE	3,205 CY
STOCKPILE RELOCATION VOLUME	11,238 CY

3/15/2014

AS-BUILT CERTIFICATION
I HEREBY DECLARE THAT THE HORIZONTAL AND VERTICAL ELEVATIONS OF THE GRADING AND EXCAVATION AREA SHOWN HEREON IS THE RESULT OF A FIELD SURVEY PERFORMED BY ME OR UNDER MY DIRECTION

ST MH RIM=15.13
SW IE=11.6 (8"ø)
NE IE=11.6 (12"ø)

ST CB RIM=15.08
(FULL OF SAND/DIRT)

ST CB RIM=15.68
SW IE=11.9 (8"ø)
NE IE=11.9 (8"ø)
SUMP=10.5

FOUND REBAR & CAP, "PACTECH" LS 18902

Port of Tacoma
OFFICE: 10314 100th St. SW, Lakewood, WA 98498
PHONE: 253-536-3950, FAX: 253-536-3950
P.O. BOX 1807 TACOMA, WA 98401

BEYLER CONSULTING
PROJECT MANAGEMENT / PRELIMINARY DESIGN / FACILITY

MARK: REVISION: BY: DATE: APPR: DATE:

CHECKED BY	DATE	PROJ. ENGR.	DATE
		draw	Mar 14, 2014

APPROVED: DIRECTOR ENGR. DATE: PORT ADDRESS: ONE SITCUM PLAZA TACOMA, WA 98401-1837

FORMER KAISER FACILITY INTERIM ACTION SPL AREA

AS-BUILT EXCAVATION PLAN

TOWNSHIP: 21 NORTH RANGE: 3 EAST SECTION: SW 1/4-36 PRINTED BY: MLLW 19.39' @ Tide 22 1933 DRAWING SCALE: AS NOTED

AB1.0 SHEET 2 OF 5

CONT/CONS: 069646 PROJECT NO: 092837 DAT-HRZ: WA83-SF PARCEL: 77

PHASE: AS-BUILT SET

THIS DRAWING IS THE PROPERTY OF THE PORT OF TACOMA AND SHALL NOT BE USED ON OTHER WORK, DISCLOSED, COPIED, IN WHOLE OR IN PART, WITHOUT WRITTEN PERMISSION

New Groundwater Monitoring Well Logs

Soil Classification System

	MAJOR DIVISIONS		USCS GRAPHIC SYMBOL	LETTER SYMBOL ⁽¹⁾	TYPICAL DESCRIPTIONS ⁽²⁾⁽³⁾
COARSE-GRAINED SOIL <small>(More than 50% of material is larger than No. 200 sieve size)</small>	GRAVEL AND GRAVELLY SOIL <small>(More than 50% of coarse fraction retained on No. 4 sieve)</small>	CLEAN GRAVEL <small>(Little or no fines)</small>		GW	Well-graded gravel; gravel/sand mixture(s); little or no fines
		GRAVEL WITH FINES <small>(Appreciable amount of fines)</small>		GP GM GC	Poorly graded gravel; gravel/sand mixture(s); little or no fines Silty gravel; gravel/sand/silt mixture(s) Clayey gravel; gravel/sand/clay mixture(s)
	SAND AND SANDY SOIL <small>(More than 50% of coarse fraction passed through No. 4 sieve)</small>	CLEAN SAND <small>(Little or no fines)</small>		SW SP	Well-graded sand; gravelly sand; little or no fines Poorly graded sand; gravelly sand; little or no fines
		SAND WITH FINES <small>(Appreciable amount of fines)</small>		SM	Silty sand; sand/silt mixture(s)
				SC	Clayey sand; sand/clay mixture(s)
	FINE-GRAINED SOIL <small>(More than 50% of material is smaller than No. 200 sieve size)</small>	SILT AND CLAY <small>(Liquid limit less than 50)</small>		ML	Inorganic silt and very fine sand; rock flour; silty or clayey fine sand or clayey silt with slight plasticity
				CL	Inorganic clay of low to medium plasticity; gravelly clay; sandy clay; silty clay; lean clay
			OL	Organic silt; organic, silty clay of low plasticity	
SILT AND CLAY <small>(Liquid limit greater than 50)</small>			MH	Inorganic silt; micaceous or diatomaceous fine sand	
			CH	Inorganic clay of high plasticity; fat clay	
			OH	Organic clay of medium to high plasticity; organic silt	
	HIGHLY ORGANIC SOIL		PT	Peat; humus; swamp soil with high organic content	

OTHER MATERIALS	GRAPHIC SYMBOL	LETTER SYMBOL	TYPICAL DESCRIPTIONS
PAVEMENT		AC or PC	Asphalt concrete pavement or Portland cement pavement
ROCK		RK	Rock (See Rock Classification)
WOOD		WD	Wood, lumber, wood chips
DEBRIS		DB	Construction debris, garbage

NOTES:

1. USCS letter symbols correspond to symbols used by the Unified Soil Classification System and ASTM classification methods. Dual letter symbols (e.g., SP-SM for sand or gravel) indicate soil with an estimated 5-15% fines. Multiple letter symbols (e.g., ML/CL) indicate borderline or multiple soil classifications.
2. Soil descriptions are based on the general approach presented in the *Standard Practice for Description and Identification of Soils (Visual-Manual Procedure)*, outlined in ASTM D 2488. Where laboratory index testing has been conducted, soil classifications are based on the *Standard Test Method for Classification of Soils for Engineering Purposes*, as outlined in ASTM D 2487.
3. Soil description terminology is based on visual estimates (in the absence of laboratory test data) of the percentages of each soil type and is defined as follows:

Primary Constituent: > 50% - "GRAVEL," "SAND," "SILT," "CLAY," etc.
 Secondary Constituents: > 30% and ≤ 50% - "very gravelly," "very sandy," "very silty," etc.
 > 15% and ≤ 30% - "gravelly," "sandy," "silty," etc.
 Additional Constituents: > 5% and ≤ 15% - "with gravel," "with sand," "with silt," etc.
 ≤ 5% - "trace gravel," "trace sand," "trace silt," etc., or not noted.

Drilling and Sampling Key

SAMPLER TYPE

SAMPLE NUMBER & INTERVAL

Code	Description
a	3.25-inch O.D., 2.42-inch I.D. Split Spoon
b	2.00-inch O.D., 1.50-inch I.D. Split Spoon
c	Shelby Tube
d	Grab Sample
e	Single-Tube Core Barrel
f	Double-Tube Core Barrel
g	Other - See text if applicable
1	300-lb Hammer, 30-inch Drop
2	140-lb Hammer, 30-inch Drop
3	Pushed
4	Rotosonic
5	Air Rotary (Rock)
6	Wash Rotary (Rock)
7	Other - See text if applicable

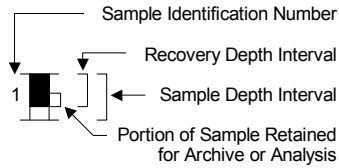

Field and Lab Test Data

Code	Description
PP = 1.0	Pocket Penetrometer, tsf
TV = 0.5	Torvane, tsf
PID = 100	Photoionization Detector VOC screening, ppm
W = 10	Moisture Content, %
D = 120	Dry Density, pcf
-200 = 60	Material smaller than No. 200 sieve, %
GS	Grain Size - See separate figure for data
AL	Atterberg Limits - See separate figure for data
VST	Vane Shear Test
GT	Other Geotechnical Testing
CA	Chemical Analysis

Groundwater

- ▽ Approximate water elevation at time of drilling (ATD).
 - ▼ Approximate water elevation at other time(s). When multiple water levels are obtained other than ATD, only a representative range is shown. See text for additional information.
- Note:** Groundwater levels can fluctuate due to precipitation, seasonal conditions, and other factors.

Well Log Graphics

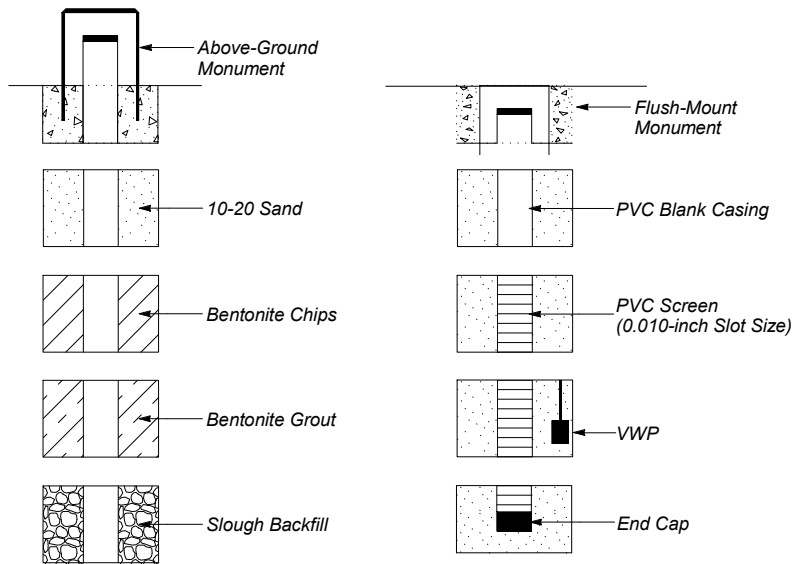

MW-SPL1

LAI Project No: 118033.010

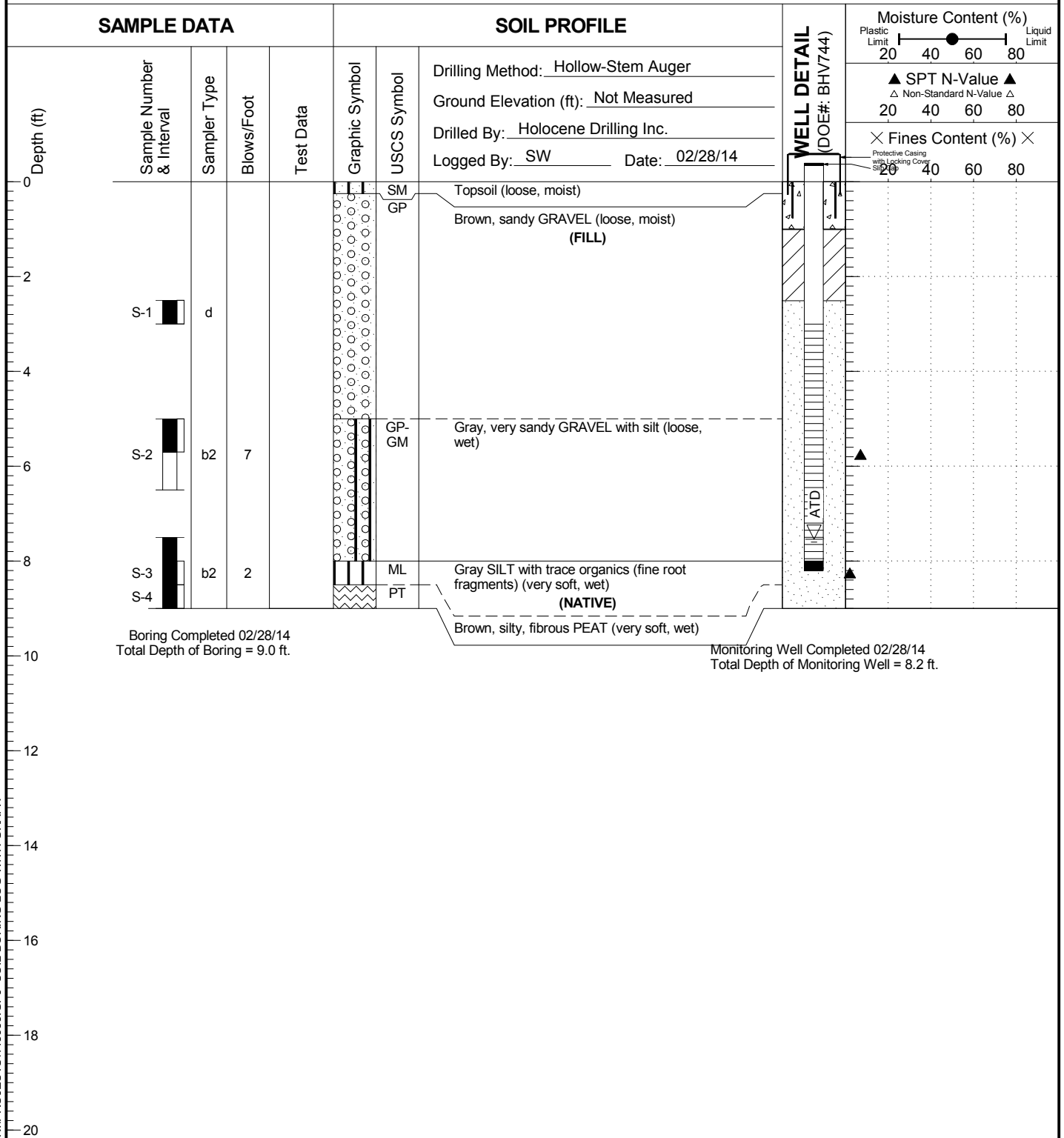

- Notes:
1. Stratigraphic contacts are based on field interpretations and are approximate.
 2. Reference to the text of this report is necessary for a proper understanding of subsurface conditions.
 3. Refer to "Soil Classification System and Key" figure for explanation of graphics and symbols.

118033.01 3/11/14 N:\PROJECTS\118033.GPJ SOIL BORING LOG WITH GRAPH



Kaiser
Tacoma, Washington

Log of Boring MW-SPL1

Figure
1-2

MW-SPL2

LAI Project No: 118033.010

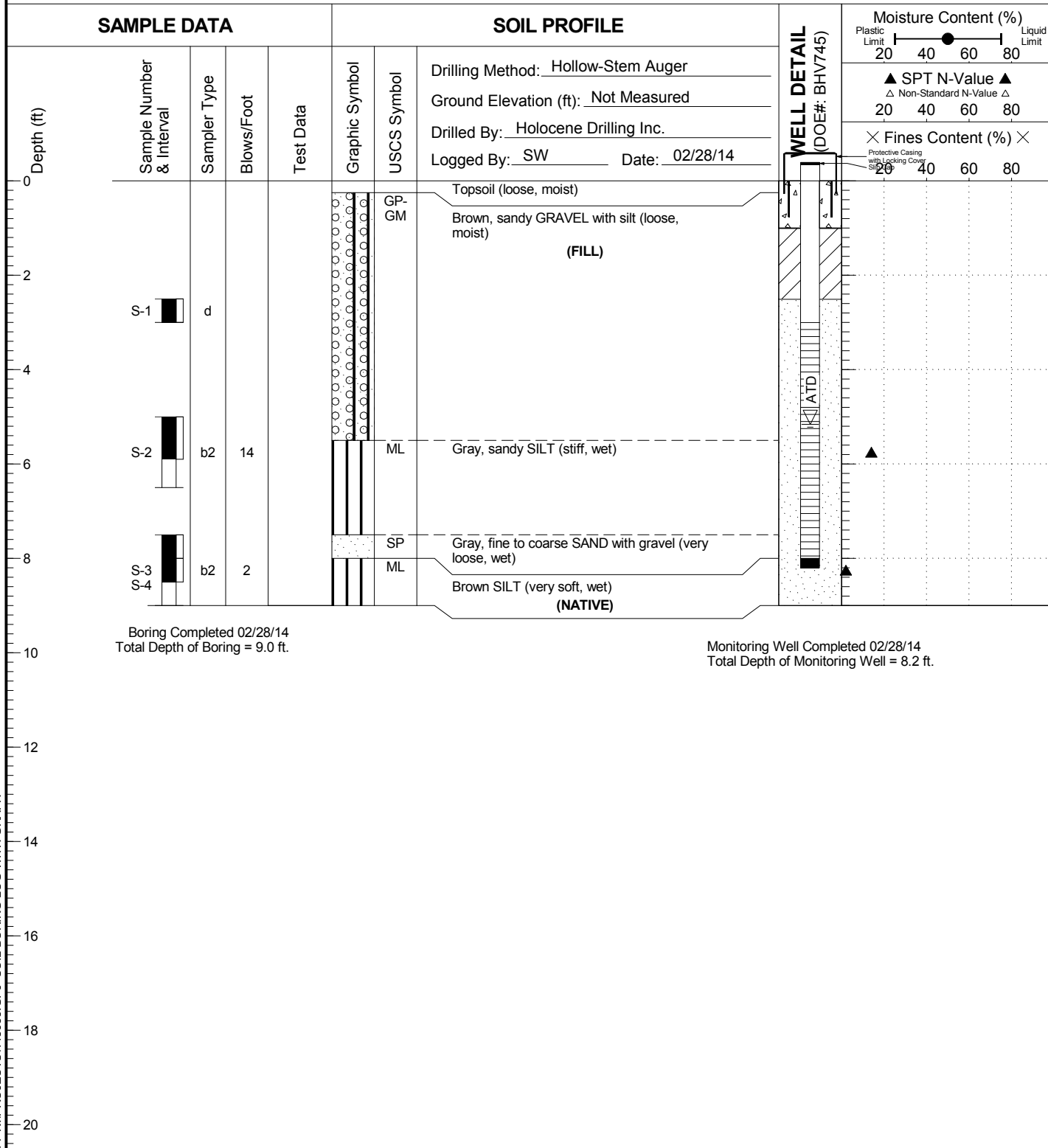

Boring Completed 02/28/14
Total Depth of Boring = 9.0 ft.

Monitoring Well Completed 02/28/14
Total Depth of Monitoring Well = 8.2 ft.

- Notes:
1. Stratigraphic contacts are based on field interpretations and are approximate.
 2. Reference to the text of this report is necessary for a proper understanding of subsurface conditions.
 3. Refer to "Soil Classification System and Key" figure for explanation of graphics and symbols.

118033.01 3/11/14 N:\PROJECTS\118033.GPJ SOIL BORING LOG WITH GRAPH

Kaiser Well Location and Elevation

Based on Port of Tacoma Horizontal and Vertical Datum

Point Number	Well Number	Ground Elevation	Top of Pipe Elevation	Top of Well Elevation	Northing	Easting
5005	SPL1	16.31	19.66	19.98	708160.389	1177232.746
5006	SPL2	16.12	20.01	20.30	708031.660	1177376.609

Analytical Laboratory Reports



Analytical Resources, Incorporated
Analytical Chemists and Consultants

August 6, 2013

Jessica Stone
Landau Associates, Inc.
950 Pacific Ave # 515
Tacoma, WA 98402

RE: Project: Kaiser IA
ARI Job No: WZ72

Dear Jessica:

Please find enclosed the original Chain-of-Custody (COC) record, sample receipt documentation, and the analytical results for the samples from the projects referenced above. Analytical Resources, Inc. (ARI) accepted four soil samples on August 2, 2013 in good condition. For further details regarding sample receipt, please refer to the enclosed Cooler Receipt Form

The samples were analyzed for cPAHs and Total Cyanide, as requested on the COC.

No analytical complications were noted.

An electronic copy of this report and all associated raw data will remain on file with ARI. If you have any questions or require additional information, please feel free to contact me at your convenience.

Sincerely,
ANALYTICAL RESOURCES, INC.

Kelly Bottem
Client Services Manager
206/695-6211
kellyb@arilabs.com

Enclosures

1 of 20

- Seattle/Edmonds (425) 778-0907
- Tacoma (253) 926-2493
- Spokane (509) 327-9737
- Portland (503) 542-1080



Chain-of-Custody Record

Date 8/2/13
Page 1 of 1

Project Name KAISER IA Project No. 118033.100.104
 Project Location/Event KAISER, PORT OF TACOMA
 Sampler's Name JCS
 Project Contact JESSICA STONE, DAVE FISCHER
 Send Results To ANNE HALVORSON, DAVE FISCHER

Testing Parameters

Turnaround Time
 Standard
 Accelerated
 1-2 DAY TAT

CYANIDE
 PAH - 8270 D

Sample I.D.	Date	Time	Matrix	No. of Containers
TPN-1-02082013	8/2/13	1015	SOIL	1
TPN-2-02082013	8/2/13	1020		1
TPE-1-02082013	8/2/13	1035		1
TPE-2-02082013	8/2/13	1030		1

Observations/Comments

Allow water samples to settle, collect aliquot from clear portion
 NWTPH-Dx - run acid wash/silica gel cleanup
 ___ run samples standardized to ___ product
 ___ Analyze for EPH if no specific product identified
 VOC/BTEX/VPH (soil):
 ___ non-preserved
 ___ preserved w/methanol
 ___ preserved w/sodium bisulfate
 ___ Freeze upon receipt
 ___ Dissolved metal water samples field filtered
 Other _____

Special Shipment/Handling or Storage Requirements

Method of Shipment

Relinquished by
 Signature [Signature]
 Printed Name JESSICA STONE
 Company LANDAU ASSOCIATES
 Date 8/2/13 Time 1400

Received by
 Signature [Signature]
 Printed Name William Cooley
 Company Landau Associates
 Date 8/2/13 Time 1400

Relinquished by
 Signature [Signature]
 Printed Name William Cooley
 Company Landau Associates
 Date 8/2/13 Time 1440

Received by
 Signature [Signature]
 Printed Name Rich Markov
 Company ARI
 Date 8/2/13 Time 1440



Cooler Receipt Form

ARI Client Landon

Project Name: Kaiser Port of Tacoma

COC No(s) _____ NA

Delivered by: Fed-Ex UPS Courier Hand Delivered Other

Assigned ARI Job No. W272

Tracking No: _____ NA

Preliminary Examination Phase:

Were intact, properly signed and dated custody seals attached to the outside of to cooler? YES NO

Were custody papers included with the cooler? YES NO

Were custody papers properly filled out (ink, signed, etc) YES NO

Temperature of Cooler(s) (°C) (recommended 2.0-6.0 °C for chemistry) 8.6

If cooler temperature is out of compliance fill out form 00070F

Cooler Accepted by: [Signature] Date: 8/2/13 Time: 1440 Temp Gun ID#: 90877952

Complete custody forms and attach all shipping documents

Log-In Phase:

Was a temperature blank included in the cooler? YES NO

What kind of packing material was used? Bubble Wrap Wet Ice Gel Packs Baggies Foam Block Paper Other: _____

Was sufficient ice used (if appropriate)? NA YES NO

Were all bottles sealed in individual plastic bags? YES NO

Did all bottles arrive in good condition (unbroken)? YES NO

Were all bottle labels complete and legible? YES NO

Did the number of containers listed on COC match with the number of containers received? YES NO

Did all bottle labels and tags agree with custody papers? YES NO

Were all bottles used correct for the requested analyses? YES NO

Do any of the analyses (bottles) require preservation? (attach preservation sheet, excluding VOCs) NA YES NO

Were all VOC vials free of air bubbles? NA YES NO

Was sufficient amount of sample sent in each bottle? YES NO

Date VOC Trip Blank was made at ARI NA

Was Sample Split by ARI: NA YES Date/Time: _____ Equipment: _____ Split by: _____

Samples Logged by TS Date: 8-2-13 Time 1440 1537

**** Notify Project Manager of discrepancies or concerns ****

Sample ID on Bottle	Sample ID on COC	Sample ID on Bottle	Sample ID on COC

Additional Notes, Discrepancies, & Resolutions:

By: _____ Date: _____

			Small → "sm"
			Peabubbles → "pb"
			Large → "lg"
			Headspace → "hs"

Sample ID Cross Reference Report



ARI Job No: WZ72
Client: Landau Associates, Inc.
Project Event: 118033.100.104
Project Name: Kaiser, Port of Tacoma

Sample ID	ARI Lab ID	ARI LIMS ID	Matrix	Sample Date/Time	VTSR
1. TPN-1-02082013	WZ72A	13-16104	Soil	08/02/13 10:15	08/02/13 14:40
2. TPN-2-02082013	WZ72B	13-16105	Soil	08/02/13 10:20	08/02/13 14:40
3. TPE-1-02082013	WZ72C	13-16106	Soil	08/02/13 10:35	08/02/13 14:40
4. TPE-2-02082013	WZ72D	13-16107	Soil	08/02/13 10:30	08/02/13 14:40

ORGANICS ANALYSIS DATA SHEET

PNA's by SW8270D GC/MS

Page 1 of 1



Sample ID: TPN-1-02082013

SAMPLE

Lab Sample ID: WZ72A

LIMS ID: 13-16104

Matrix: Soil

Data Release Authorized: *AS*

Reported: 08/05/13

QC Report No: WZ72-Landau Associates, Inc.

Project: Kaiser, Port of Tacoma

118033.100.104

Date Sampled: 08/02/13

Date Received: 08/02/13

Date Extracted: 08/03/13

Date Analyzed: 08/03/13 21:56

Instrument/Analyst: NT6/JZ

GPC Cleanup: No

Alumina: No

Silica Gel: No

Sample Amount: 8.18 g-dry-wt

Final Extract Volume: 0.5 mL

Dilution Factor: 1.00

Percent Moisture: 15.8%

CAS Number	Analyte	RL	Result
56-55-3	Benzo (a) anthracene	61	2,500
218-01-9	Chrysene	61	4,300
50-32-8	Benzo (a) pyrene	61	2,000
193-39-5	Indeno (1,2,3-cd) pyrene	61	1,000
53-70-3	Dibenz (a,h) anthracene	61	340
TOTBFA	Total Benzofluoranthenes	61	4,000

Reported in µg/kg (ppb)

Semivolatile Surrogate Recovery

d14-p-Terphenyl	49.2%
2-Fluorobiphenyl	76.0%

ORGANICS ANALYSIS DATA SHEET

PNAs by SW8270D GC/MS

Page 1 of 1

Sample ID: TPN-2-02082013

SAMPLE

Lab Sample ID: WZ72B

LIMS ID: 13-16105

Matrix: Soil

Data Release Authorized: 

Reported: 08/05/13

QC Report No: WZ72-Landau Associates, Inc.

Project: Kaiser, Port of Tacoma

118033.100.104

Date Sampled: 08/02/13

Date Received: 08/02/13

Date Extracted: 08/03/13

Date Analyzed: 08/03/13 22:30

Instrument/Analyst: NT6/JZ

GPC Cleanup: No

Alumina: No

Silica Gel: No

Sample Amount: 8.54 g-dry-wt

Final Extract Volume: 0.5 mL

Dilution Factor: 1.00

Percent Moisture: 9.0%

CAS Number	Analyte	RL	Result
56-55-3	Benzo(a)anthracene	58	< 58 U
218-01-9	Chrysene	58	< 58 U
50-32-8	Benzo(a)pyrene	58	< 58 U
193-39-5	Indeno(1,2,3-cd)pyrene	58	< 58 U
53-70-3	Dibenz(a,h)anthracene	58	< 58 U
TOTBFA	Total Benzofluoranthenes	58	< 58 U

Reported in µg/kg (ppb)

Semivolatile Surrogate Recovery

d14-p-Terphenyl	94.0%
2-Fluorobiphenyl	76.8%

ORGANICS ANALYSIS DATA SHEET

PNA's by SW8270D GC/MS

Page 1 of 1

Sample ID: TPE-1-02082013

SAMPLE

Lab Sample ID: WZ72C

LIMS ID: 13-16106

Matrix: Soil

Data Release Authorized: *B*

Reported: 08/05/13

QC Report No: WZ72-Landau Associates, Inc.

Project: Kaiser, Port of Tacoma

118033.100.104

Date Sampled: 08/02/13

Date Received: 08/02/13

Date Extracted: 08/03/13

Date Analyzed: 08/03/13 23:04

Instrument/Analyst: NT6/JZ

GPC Cleanup: No

Alumina: No

Silica Gel: No

Sample Amount: 8.07 g-dry-wt

Final Extract Volume: 0.5 mL

Dilution Factor: 1.00

Percent Moisture: 14.1%

CAS Number	Analyte	RL	Result
56-55-3	Benzo (a) anthracene	62	7,200 ES
218-01-9	Chrysene	62	8,400 ES
50-32-8	Benzo (a) pyrene	62	6,400 ES
193-39-5	Indeno (1,2,3-cd) pyrene	62	4,200
53-70-3	Dibenz (a,h) anthracene	62	1,700
TOTBFA	Total Benzofluoranthenes	62	9,000

Reported in µg/kg (ppb)

Semivolatile Surrogate Recovery

d14-p-Terphenyl	92.0%
2-Fluorobiphenyl	82.0%

ORGANICS ANALYSIS DATA SHEET

PNAs by SW8270D GC/MS

Page 1 of 1

Sample ID: TPE-1-02082013

DILUTION

Lab Sample ID: WZ72C

LIMS ID: 13-16106

Matrix: Soil

Data Release Authorized: *AS*

Reported: 08/05/13

QC Report No: WZ72-Landau Associates, Inc.

Project: Kaiser, Port of Tacoma

118033.100.104

Date Sampled: 08/02/13

Date Received: 08/02/13

Date Extracted: 08/03/13

Date Analyzed: 08/04/13 13:45

Instrument/Analyst: NT6/JZ

GPC Cleanup: No

Alumina: No

Silica Gel: No

Sample Amount: 8.07 g-dry-wt

Final Extract Volume: 0.5 mL

Dilution Factor: 3.00

Percent Moisture: 14.1%

CAS Number	Analyte	RL	Result
56-55-3	Benzo (a) anthracene	190	7,500
218-01-9	Chrysene	190	10,000
50-32-8	Benzo (a) pyrene	190	8,300
193-39-5	Indeno (1,2,3-cd) pyrene	190	5,000
53-70-3	Dibenz (a,h) anthracene	190	1,900
TOTBFA	Total Benzofluoranthenes	190	12,000

Reported in µg/kg (ppb)

Semivolatile Surrogate Recovery

d14-p-Terphenyl	79.8%
2-Fluorobiphenyl	78.2%

ORGANICS ANALYSIS DATA SHEET

PNAs by SW8270D GC/MS

Page 1 of 1

Sample ID: TPE-2-02082013

SAMPLE

Lab Sample ID: WZ72D
LIMS ID: 13-16107
Matrix: Soil
Data Release Authorized: *AS*
Reported: 08/05/13

QC Report No: WZ72-Landau Associates, Inc.
Project: Kaiser, Port of Tacoma
118033.100.104
Date Sampled: 08/02/13
Date Received: 08/02/13

Date Extracted: 08/03/13
Date Analyzed: 08/03/13 23:38
Instrument/Analyst: NT6/JZ
GPC Cleanup: No
Alumina: No
Silica Gel: No

Sample Amount: 8.67 g-dry-wt
Final Extract Volume: 0.5 mL
Dilution Factor: 1.00
Percent Moisture: 7.9%

CAS Number	Analyte	RL	Result
56-55-3	Benzo(a)anthracene	58	< 58 U
218-01-9	Chrysene	58	< 58 U
50-32-8	Benzo(a)pyrene	58	< 58 U
193-39-5	Indeno(1,2,3-cd)pyrene	58	< 58 U
53-70-3	Dibenz(a,h)anthracene	58	< 58 U
TOTBFA	Total Benzofluoranthenes	58	< 58 U

Reported in µg/kg (ppb)

Semivolatile Surrogate Recovery

d14-p-Terphenyl	78.8%
2-Fluorobiphenyl	70.4%

ORGANICS ANALYSIS DATA SHEET

PNAs by SW8270D GC/MS

Page 1 of 1



Sample ID: MB-080313

METHOD BLANK

Lab Sample ID: MB-080313

LIMS ID: 13-16104

Matrix: Soil

Data Release Authorized: *AS*

Reported: 08/05/13

QC Report No: WZ72-Landau Associates, Inc.

Project: Kaiser, Port of Tacoma

118033.100.104

Date Sampled: NA

Date Received: NA

Date Extracted: 08/03/13

Date Analyzed: 08/03/13 20:14

Instrument/Analyst: NT6/JZ

GPC Cleanup: No

Alumina: No

Silica Gel: No

Sample Amount: 7.50 g-dry-wt

Final Extract Volume: 0.5 mL

Dilution Factor: 1.00

Percent Moisture: NA

CAS Number	Analyte	RL	Result
56-55-3	Benzo(a)anthracene	67	< 67 U
218-01-9	Chrysene	67	< 67 U
50-32-8	Benzo(a)pyrene	67	< 67 U
193-39-5	Indeno(1,2,3-cd)pyrene	67	< 67 U
53-70-3	Dibenz(a,h)anthracene	67	< 67 U
TOTBFA	Total Benzofluoranthenes	67	< 67 U

Reported in µg/kg (ppb)

Semivolatile Surrogate Recovery

d14-p-Terphenyl	98.4%
2-Fluorobiphenyl	80.0%

SW8270 PNA SURROGATE RECOVERY SUMMARY



Matrix: Soil

QC Report No: WZ72-Landau Associates, Inc.
 Project: Kaiser, Port of Tacoma
 118033.100.104

Client ID	TER	FBP	TOT OUT
MB-080313	98.4%	80.0%	0
LCS-080313	95.2%	77.6%	0
LCSD-080313	91.2%	78.4%	0
TPN-1-02082013	49.2%	76.0%	0
TPN-2-02082013	94.0%	76.8%	0
TPE-1-02082013	92.0%	82.0%	0
TPE-1-02082013 DL	79.8%	78.2%	0
TPE-2-02082013	78.8%	70.4%	0

	LCS/MB LIMITS	QC LIMITS
(TER) = d14-p-Terphenyl	(30-160)	(30-160)
(FBP) = 2-Fluorobiphenyl	(30-160)	(30-160)

Prep Method: SW3546
 Log Number Range: 13-16104 to 13-16107

ORGANICS ANALYSIS DATA SHEET

PNAs by SW8270D GC/MS

Page 1 of 1

Sample ID: LCS-080313

LCS/LCSD

Lab Sample ID: LCS-080313

LIMS ID: 13-16104

Matrix: Soil

Data Release Authorized: *B*

Reported: 08/05/13

QC Report No: WZ72-Landau Associates, Inc.

Project: Kaiser, Port of Tacoma

118033.100.104

Date Sampled: NA

Date Received: 08/02/13

Date Extracted LCS/LCSD: 08/03/13

Sample Amount LCS: 7.50 g-dry-wt

LCSD: 7.50 g-dry-wt

Date Analyzed LCS: 08/03/13 20:48

Final Extract Volume LCS: 0.50 mL

LCSD: 08/03/13 21:22

LCSD: 0.50 mL

Instrument/Analyst LCS: NT6/JZ

Dilution Factor LCS: 1.00

LCSD: NT6/JZ

LCSD: 1.00

GPC Cleanup: No

Alumina Cleanup: No

Silica Gel Cleanup: No

Analyte	Spike		LCS		Spike		LCSD	
	LCS	Added-LCS	Recovery	LCS	Added-LCSD	Recovery	RPD	
Benzo(a)anthracene	1430	1670	85.6%	1470	1670	88.0%	2.8%	
Chrysene	1490	1670	89.2%	1520	1670	91.0%	2.0%	
Benzo(a)pyrene	1450	1670	86.8%	1490	1670	89.2%	2.7%	
Indeno(1,2,3-cd)pyrene	1560	1670	93.4%	1630	1670	97.6%	4.4%	
Dibenz(a,h)anthracene	1590	1670	95.2%	1670	1670	100%	4.9%	
Total Benzofluoranthenes	3120	3330	93.7%	3230	3330	97.0%	3.5%	

Semivolatile Surrogate Recovery

	LCS	LCSD
d14-p-Terphenyl	95.2%	91.2%
2-Fluorobiphenyl	77.6%	78.4%

Results reported in µg/kg

RPD calculated using sample concentrations per SW846.

SAMPLE RESULTS-CONVENTIONALS
WZ72-Landau Associates, Inc.



Matrix: Soil
Data Release Authorized:
Reported: 08/06/13

A handwritten signature in black ink, appearing to be 'JL' or similar, written over the 'Data Release Authorized' line.

Project: Kaiser, Port of Tacoma
Event: 118033.100.104
Date Sampled: 08/02/13
Date Received: 08/02/13

Client ID: TPN-1-02082013
ARI ID: 13-16104 WZ72A

Analyte	Date	Method	Units	RL	Sample
Total Solids	08/05/13 080513#1	SM2540B	Percent	0.01	86.76
Total Cyanide	08/05/13 080513#1	EPA 335.4	mg/kg	0.624	19.6

RL Analytical reporting limit
U Undetected at reported detection limit

SAMPLE RESULTS-CONVENTIONALS
WZ72-Landau Associates, Inc.



Matrix: Soil
Data Release Authorized:
Reported: 08/06/13

A handwritten signature in black ink, appearing to be 'GJ' or similar, written over the 'Data Release Authorized' text.

Project: Kaiser, Port of Tacoma
Event: 118033.100.104
Date Sampled: 08/02/13
Date Received: 08/02/13

Client ID: TPN-2-02082013
ARI ID: 13-16105 WZ72B

Analyte	Date	Method	Units	RL	Sample
Total Solids	08/05/13 080513#1	SM2540B	Percent	0.01	92.86
Total Cyanide	08/05/13 080513#1	EPA 335.4	mg/kg	0.109	4.17

RL Analytical reporting limit
U Undetected at reported detection limit

SAMPLE RESULTS-CONVENTIONALS
WZ72-Landau Associates, Inc.



Matrix: Soil
Data Release Authorized:
Reported: 08/06/13

A handwritten signature in black ink, appearing to be 'J. Landau', is written over the 'Data Release Authorized' text.

Project: Kaiser, Port of Tacoma
Event: 118033.100.104
Date Sampled: 08/02/13
Date Received: 08/02/13

Client ID: TPE-1-02082013
ARI ID: 13-16106 WZ72C

Analyte	Date	Method	Units	RL	Sample
Total Solids	08/05/13 080513#1	SM2540B	Percent	0.01	89.67
Total Cyanide	08/05/13 080513#1	EPA 335.4	mg/kg	2.34	58.1

RL Analytical reporting limit
U Undetected at reported detection limit

SAMPLE RESULTS-CONVENTIONALS
WZ72-Landau Associates, Inc.



Matrix: Soil
Data Release Authorized:
Reported: 08/06/13

A handwritten signature in black ink, appearing to be 'J. Landau', written over the 'Data Release Authorized' text.

Project: Kaiser, Port of Tacoma
Event: 118033.100.104
Date Sampled: 08/02/13
Date Received: 08/02/13

Client ID: TPE-2-02082013
ARI ID: 13-16107 WZ72D

Analyte	Date	Method	Units	RL	Sample
Total Solids	08/05/13 080513#1	SM2540B	Percent	0.01	91.47
Total Cyanide	08/05/13 080513#1	EPA 335.4	mg/kg	0.110	2.63

RL Analytical reporting limit
U Undetected at reported detection limit

METHOD BLANK RESULTS-CONVENTIONALS
WZ72-Landau Associates, Inc.

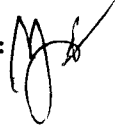

Matrix: Soil
Data Release Authorized: 
Reported: 08/06/13

Project: Kaiser, Port of Tacoma
Event: 118033.100.104
Date Sampled: NA
Date Received: NA

Analyte	Date	Units	Blank	QC ID
Total Solids	08/05/13	Percent	< 0.01 U	ICB
Total Cyanide	08/05/13	mg/kg	< 0.100 U	PREP

STANDARD REFERENCE RESULTS-CONVENTIONALS
WZ72-Landau Associates, Inc.

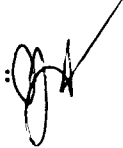

Matrix: Soil
Data Release Authorized: 
Reported: 08/06/13

Project: Kaiser, Port of Tacoma
Event: 118033.100.104
Date Sampled: NA
Date Received: NA

Analyte/SRM ID	Date	Units	SRM	True Value	Recovery
Total Cyanide ERA 220811	08/05/13	mg/kg	26.0	28.1	92.5%

REPLICATE RESULTS-CONVENTIONALS
WZ72-Landau Associates, Inc.



Matrix: Soil
Data Release Authorized:
Reported: 08/06/13

A handwritten signature in black ink, appearing to be 'J. Landau', written over the 'Data Release Authorized' line.

Project: Kaiser, Port of Tacoma
Event: 118033.100.104
Date Sampled: 08/02/13
Date Received: 08/02/13

Analyte	Date	Units	Sample	Replicate (s)	RPD/RSD
ARI ID: WZ72A Client ID: TPN-1-02082013					
Total Solids	08/05/13	Percent	86.76	90.26	4.0%
Total Cyanide	08/05/13	mg/kg	19.6	18.8	4.2%

MS/MSD RESULTS-CONVENTIONALS
WZ72-Landau Associates, Inc.

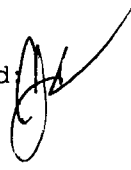

Matrix: Soil
Data Release Authorized: 
Reported: 08/06/13

Project: Kaiser, Port of Tacoma
Event: 118033.100.104
Date Sampled: 08/02/13
Date Received: 08/02/13

Analyte	Date	Units	Sample	Spike	Spike Added	Recovery
ARI ID: WZ72A Client ID: TPN-1-02082013						
Total Cyanide	08/05/13	mg/kg	19.6	23.3	3.58	103.4%



Analytical Resources, Incorporated
Analytical Chemists and Consultants

August 21, 2013

Jessica Stone
Landau Associates, Inc.
950 Pacific Ave # 515
Tacoma, WA 98402

RE: Project: Kaiser IA
ARI Job No: XB45

Dear Jessica:

Please find enclosed the original Chain-of-Custody (COC) record, sample receipt documentation, and the analytical results for the samples from the projects referenced above. Analytical Resources, Inc. (ARI) accepted three soil samples on August 16, 2013 in good condition. For further details regarding sample receipt, please refer to the enclosed Cooler Receipt Form

The samples were analyzed for cPAHs, as requested on the COC.

No analytical complications were noted.

An electronic copy of this report and all associated raw data will remain on file with ARI. If you have any questions or require additional information, please feel free to contact me at your convenience.

Sincerely,
ANALYTICAL RESOURCES, INC.

A handwritten signature in black ink that reads "Kelly Bottom".

Kelly Bottom
Client Services Manager
206/695-6211
kellyb@arilabs.com

Enclosures

1 of 10

XBLFS

Chain-of-Custody Record

Project Name Kaiser IA Project No. 118033.100.104
 Project Location/Event Kaiser, POT
 Sampler's Name Dave Rupert
 Project Contact Dave Pischer
 Send Results To Aime Halvorsen, Bill Evans, Dave Pischer

Testing Parameters

Turnaround Time
 Standard
 Accelerated
 1 Week

CPAH - 8270 D

Sample I.D.	Date	Time	Matrix	No. of Containers
SPL-SP2E-20130613	8/13	1516	soil	1
SPL-SP1-20130613	8/13	1452	soil	1
SPL-SP1W-20130813	8/13	1507	soil	1

Observations/Comments

Allow water samples to settle, collect aliquot from clear portion
 NWTPH-Dx - run acid wash/silica gel cleanup
 ___ run samples standardized to _____ product
 ___ Analyze for EPH if no specific product identified
 VOC/BTEX/VPH (soil):
 ___ non-preserved
 ___ preserved w/methanol
 ___ preserved w/sodium bisulfate
 ___ Freeze upon receipt
 ___ Dissolved metal water samples field filtered
 Other _____

Special Shipment/Handling or Storage Requirements on ice

Method of Shipment courier

Relinquished by
 Signature [Signature]
 Printed Name Stem Mort
 Company Landau Associates
 Date 8/16/13 Time 1300

Received by
 Signature [Signature]
 Printed Name ARI
 Company _____
 Date 8/16/13 Time 1300

Relinquished by
 Signature _____
 Printed Name _____
 Company _____
 Date _____ Time _____

Received by
 Signature _____
 Printed Name _____
 Company _____
 Date _____ Time _____



Cooler Receipt Form

ARI Client: Lanlan
 COC No(s): _____
 Assigned ARI Job No: XB45

Project Name: Kaiser IA
 Delivered by: Fed-Ex UPS Courier Hand Delivered Other: _____
 Tracking No: _____

Preliminary Examination Phase:

Were intact, properly signed and dated custody seals attached to the outside of to cooler? YES NO
 Were custody papers included with the cooler? YES NO
 Were custody papers properly filled out (ink, signed, etc.) YES NO
 Temperature of Cooler(s) (°C) (recommended 2.0-6.0 °C for chemistry) _____
 If cooler temperature is out of compliance fill out form 00070F _____
 Cooler Accepted by: _____ Date: 8/16/13 Time: 1300 Temp Gun ID#: 122412224 4.6

Complete custody forms and attach all shipping documents

Log-In Phase:

Was a temperature blank included in the cooler? YES NO
 What kind of packing material was used? ... Bubble Wrap Wet Ice Gel Packs Foam Block Paper Other: _____
 Was sufficient ice used (if appropriate)? NA YES NO
 Were all bottles sealed in individual plastic bags? YES NO
 Did all bottles arrive in good condition (unbroken)? YES NO
 Were all bottle labels complete and legible? YES NO
 Did the number of containers listed on COC match with the number of containers received? YES NO
 Did all bottle labels and tags agree with custody papers? YES NO
 Were all bottles used correct for the requested analyses? YES NO
 Do any of the analyses (bottles) require preservation? (attach preservation sheet, excluding VOCs) NA YES NO
 Were all VOC vials free of air bubbles? NA YES NO
 Was sufficient amount of sample sent in each bottle? YES NO
 Date VOC Trip Blank was made at ARI: NA _____
 Was Sample Split by ARI: NA YES Date/Time: _____ Equipment: _____ Split by: _____

Samples Logged by: AV Date: 8/16/13 Time: 1544

**** Notify Project Manager of discrepancies or concerns ****

Sample ID on Bottle	Sample ID on COC	Sample ID on Bottle	Sample ID on COC

Additional Notes, Discrepancies, & Resolutions:

By: _____ Date: _____

			Small → "sm"
			Peabubbles → "pb"
			Large → "lg"
			Headspace → "hs"

Sample ID Cross Reference Report



ARI Job No: XB45
Client: Landau Associates, Inc.
Project Event: 118033.100.104
Project Name: Kaiser IA

Sample ID	ARI Lab ID	ARI LIMS ID	Matrix	Sample Date/Time	VTSR
1. SPL-SP2E-20130813	XB45A	13-17188	Soil	08/13/13 15:16	08/16/13 13:00
2. SPL-SP1-20130813	XB45B	13-17189	Soil	08/13/13 14:52	08/16/13 13:00
3. SPL-SP2W-20130813	XB45C	13-17190	Soil	08/13/13 15:07	08/16/13 13:00

ORGANICS ANALYSIS DATA SHEET

PNA's by SW8270D GC/MS

Page 1 of 1



Sample ID: SPL-SP2E-20130813

SAMPLE

Lab Sample ID: XB45A

LIMS ID: 13-17188

Matrix: Soil

Data Release Authorized: *[Signature]*

Reported: 08/21/13

QC Report No: XB45-Landau Associates, Inc.

Project: Kaiser IA

118033.100.104

Date Sampled: 08/13/13

Date Received: 08/16/13

Date Extracted: 08/17/13

Date Analyzed: 08/19/13 21:21

Instrument/Analyst: NT6/JZ

GPC Cleanup: No

Alumina: No

Silica Gel: No

Sample Amount: 7.96 g-dry-wt

Final Extract Volume: 0.5 mL

Dilution Factor: 1.00

Percent Moisture: 2.9%

CAS Number	Analyte	RL	Result
56-55-3	Benzo (a) anthracene	63	290
218-01-9	Chrysene	63	1,400
50-32-8	Benzo (a) pyrene	63	220
193-39-5	Indeno (1,2,3-cd) pyrene	63	220
53-70-3	Dibenz (a,h) anthracene	63	97
TOTBFA	Total Benzofluoranthenes	63	1,300

Reported in µg/kg (ppb)

Semivolatile Surrogate Recovery

d14-p-Terphenyl	77.6%
2-Fluorobiphenyl	70.0%

ORGANICS ANALYSIS DATA SHEET

PNA's by SW8270D GC/MS

Page 1 of 1

**Sample ID: SPL-SP1-20130813
SAMPLE**

Lab Sample ID: XB45B
LIMS ID: 13-17189
Matrix: Soil
Data Release Authorized: *[Signature]*
Reported: 08/21/13

QC Report No: XB45-Landau Associates, Inc.
Project: Kaiser IA
118033.100.104
Date Sampled: 08/13/13
Date Received: 08/16/13

Date Extracted: 08/17/13
Date Analyzed: 08/19/13 21:55
Instrument/Analyst: NT6/JZ
GPC Cleanup: No
Alumina: No
Silica Gel: No

Sample Amount: 7.81 g-dry-wt
Final Extract Volume: 0.5 mL
Dilution Factor: 1.00
Percent Moisture: 4.0%

CAS Number	Analyte	RL	Result
56-55-3	Benzo(a)anthracene	64	< 64 U
218-01-9	Chrysene	64	< 64 U
50-32-8	Benzo(a)pyrene	64	< 64 U
193-39-5	Indeno(1,2,3-cd)pyrene	64	< 64 U
53-70-3	Dibenz(a,h)anthracene	64	< 64 U
TOTBFA	Total Benzofluoranthenes	64	100

Reported in µg/kg (ppb)

Semivolatile Surrogate Recovery

d14-p-Terphenyl	80.0%
2-Fluorobiphenyl	76.0%

ORGANICS ANALYSIS DATA SHEET

PNAs by SW8270D GC/MS

Page 1 of 1

Sample ID: SPL-SP2W-20130813

SAMPLE

Lab Sample ID: XB45C

LIMS ID: 13-17190

Matrix: Soil

Data Release Authorized: *[Signature]*

Reported: 08/21/13

QC Report No: XB45-Landau Associates, Inc.

Project: Kaiser IA

118033.100.104

Date Sampled: 08/13/13

Date Received: 08/16/13

Date Extracted: 08/17/13

Date Analyzed: 08/19/13 22:29

Instrument/Analyst: NT6/JZ

GPC Cleanup: No

Alumina: No

Silica Gel: No

Sample Amount: 7.91 g-dry-wt

Final Extract Volume: 0.5 mL

Dilution Factor: 1.00

Percent Moisture: 2.1%

CAS Number	Analyte	RL	Result
56-55-3	Benzo (a) anthracene	63	340
218-01-9	Chrysene	63	1,700
50-32-8	Benzo (a) pyrene	63	250
193-39-5	Indeno (1,2,3-cd) pyrene	63	200
53-70-3	Dibenz (a,h) anthracene	63	90
TOTBFA	Total Benzofluoranthenes	63	1,400

Reported in µg/kg (ppb)

Semivolatile Surrogate Recovery

d14-p-Terphenyl	79.2%
2-Fluorobiphenyl	74.0%

ORGANICS ANALYSIS DATA SHEET

PNA's by SW8270D GC/MS

Page 1 of 1



Sample ID: MB-081713

METHOD BLANK

Lab Sample ID: MB-081713

LIMS ID: 13-17188

Matrix: Soil

Data Release Authorized: *RB*

Reported: 08/21/13

QC Report No: XB45-Landau Associates, Inc.

Project: Kaiser IA

118033.100.104

Date Sampled: NA

Date Received: NA

Date Extracted: 08/17/13

Date Analyzed: 08/19/13 11:08

Instrument/Analyst: NT6/JZ

GPC Cleanup: No

Alumina: No

Silica Gel: No

Sample Amount: 7.50 g-dry-wt

Final Extract Volume: 0.5 mL

Dilution Factor: 1.00

Percent Moisture: NA

CAS Number	Analyte	RL	Result
56-55-3	Benzo(a)anthracene	67	< 67 U
218-01-9	Chrysene	67	< 67 U
50-32-8	Benzo(a)pyrene	67	< 67 U
193-39-5	Indeno(1,2,3-cd)pyrene	67	< 67 U
53-70-3	Dibenz(a,h)anthracene	67	< 67 U
TOTBFA	Total Benzofluoranthenes	67	< 67 U

Reported in µg/kg (ppb)

Semivolatile Surrogate Recovery

d14-p-Terphenyl	88.0%
2-Fluorobiphenyl	69.6%

SW8270 PNA SURROGATE RECOVERY SUMMARY



Matrix: Soil

QC Report No: XB45-Landau Associates, Inc.
 Project: Kaiser IA
 118033.100.104

<u>Client ID</u>	<u>TER</u>	<u>FBP</u>	<u>TOT OUT</u>
MB-081713	88.0%	69.6%	0
LCS-081713	86.0%	70.8%	0
LCSD-081713	89.2%	70.8%	0
SPL-SP2E-20130813	77.6%	70.0%	0
SPL-SP1-20130813	80.0%	76.0%	0
SPL-SP2W-20130813	79.2%	74.0%	0

	LCS/MB LIMITS	QC LIMITS
(TER) = d14-p-Terphenyl	(30-160)	(30-160)
(FBP) = 2-Fluorobiphenyl	(30-160)	(30-160)

Prep Method: SW3546
 Log Number Range: 13-17188 to 13-17190

ORGANICS ANALYSIS DATA SHEET

PNA's by SW8270D GC/MS

Page 1 of 1

**Sample ID: LCS-081713
LCS/LCSD**

Lab Sample ID: LCS-081713

LIMS ID: 13-17188

Matrix: Soil

Data Release Authorized: *[Signature]*

Reported: 08/21/13

QC Report No: XB45-Landau Associates, Inc.

Project: Kaiser IA

118033.100.104

Date Sampled: NA

Date Received: 08/16/13

Date Extracted LCS/LCSD: 08/17/13

Sample Amount LCS: 7.50 g-dry-wt

LCSD: 7.50 g-dry-wt

Date Analyzed LCS: 08/19/13 11:42

Final Extract Volume LCS: 0.50 mL

LCSD: 08/19/13 12:16

LCSD: 0.50 mL

Instrument/Analyst LCS: NT6/JZ

Dilution Factor LCS: 1.00

LCSD: NT6/JZ

LCSD: 1.00

GPC Cleanup: No

Alumina Cleanup: No

Silica Gel Cleanup: No

Analyte	Spike		LCS		Spike		LCSD	
	LCS	Added-LCS	Recovery	LCSD	Added-LCSD	Recovery	RPD	
Benzo(a)anthracene	1340	1670	80.2%	1460	1670	87.4%	8.6%	
Chrysene	1330	1670	79.6%	1440	1670	86.2%	7.9%	
Benzo(a)pyrene	1340	1670	80.2%	1430	1670	85.6%	6.5%	
Indeno(1,2,3-cd)pyrene	1350	1670	80.8%	1470	1670	88.0%	8.5%	
Dibenz(a,h)anthracene	1380	1670	82.6%	1500	1670	89.8%	8.3%	
Total Benzofluoranthenes	2910	3330	87.4%	3170	3330	95.2%	8.6%	

Semivolatile Surrogate Recovery

	LCS	LCSD
d14-p-Terphenyl	86.0%	89.2%
2-Fluorobiphenyl	70.8%	70.8%

Results reported in µg/kg

RPD calculated using sample concentrations per SW846.



Analytical Resources, Incorporated
Analytical Chemists and Consultants

August 29, 2013

Jessica Stone
Landau Associates, Inc.
950 Pacific Ave # 515
Tacoma, WA 98402

RE: Project: Kaiser IA
ARI Job No: XC60

Dear Jessica:

Please find enclosed the original Chain-of-Custody (COC) record, sample receipt documentation, and the analytical results for the samples from the projects referenced above. Analytical Resources, Inc. (ARI) accepted two soil samples on August 28, 2013 in good condition. For further details regarding sample receipt, please refer to the enclosed Cooler Receipt Form.

The samples were analyzed for cPAHs, as requested on the COC.

No analytical complications were noted.

An electronic copy of this report and all associated raw data will remain on file with ARI. If you have any questions or require additional information, please feel free to contact me at your convenience.

Sincerely,
ANALYTICAL RESOURCES, INC.

A handwritten signature in black ink, appearing to read "Kelly Bottem".

Kelly Bottem
Client Services Manager
206/695-6211
kellyb@arilabs.com

Enclosures

1 of 10

- Seattle/Edmonds (425) 778-0907
- Tacoma (253) 926-2493
- Spokane (509) 327-9737
- Portland (503) 542-1080



Chain-of-Custody Record

Date 8/27/13
Page 1 of 1

Project Name Kaiser IA Project No. 116032.100.104

Project Location/Event 3400 Taylor Way, Port of Tacoma

Sampler's Name Dave Rupert

Project Contact Dave Fischer

Send Results To Jess Stone Anne Halverson Bill Evans Dave Fischer

Sample I.D.	Date	Time	Matrix	No. of Containers	Testing Parameters	Observations/Comments	Method of Shipment
<u>SPL-1-20130827</u>	<u>8/27/13</u>	<u>1201</u>	<u>Soil</u>	<u>1</u>		<u>X</u> Allow water samples to settle, collect aliquot from clear portion	
<u>SPL-2-20130827</u>	<u>8/27/13</u>	<u>1215</u>	<u>Soil</u>	<u>1</u>		<u>X</u> NWTPH-Dx - run acid wash/silica gel cleanup	
						<u>run samples standardized to _____ product</u>	
						<u>Analyze for EPH if no specific product identified</u>	
						<u>VOC/BTEX/VPH (soil):</u>	
						<u>non-preserved</u>	
						<u>preserved w/methanol</u>	
						<u>preserved w/sodium bisulfate</u>	
						<u>Freeze upon receipt</u>	
						<u>Dissolved metal water samples field filtered</u>	
						<u>Other _____</u>	
Special Shipment/Handling or Storage Requirements <u>Ice</u>							Method of Shipment <u>Courier</u>

Turnaround Time
 Standard
 Accelerated
 1-2 day

Relinquished by
 Signature Dave Rupert
 Printed Name Dave Rupert
 Company Kaiser Associates
 Date 8/28/13 Time 1232

Received by
 Signature [Signature]
 Printed Name Rich Herber
 Company ARI
 Date 8/28/13 Time 1232

Relinquished by
 Signature _____
 Printed Name _____
 Company _____
 Date _____ Time _____

Received by
 Signature _____
 Printed Name _____
 Company _____
 Date _____ Time _____



Cooler Receipt Form

ARI Client Landau

Project Name Kaiser IA

COC No(s): _____ (NA)

Delivered by: Fed-Ex UPS Courier Hand Delivered Other: _____

Assigned ARI Job No XCL00

Tracking No _____ (NA)

Preliminary Examination Phase:

Were intact, properly signed and dated custody seals attached to the outside of to cooler? YES NO

Were custody papers included with the cooler? YES YES NO

Were custody papers properly filled out (ink, signed, etc.) YES YES NO

Temperature of Cooler(s) (°C) (recommended 2 0-6.0 °C for chemistry) _____ NO 6.6

If cooler temperature is out of compliance, fill out form 00070F

Cooler Accepted by: _____ Date: 8/29/13 Time: 1232 Temp Gun ID#: 122412224

Complete custody forms and attach all shipping documents

Log-In Phase:

Was a temperature blank included in the cooler? YES NO

What kind of packing material was used? ... Bubble Wrap Wet Ice Gel Packs Baggies Foam Block Paper Other: _____

Was sufficient ice used (if appropriate)? _____ NA YES NO

Were all bottles sealed in individual plastic bags? _____ YES NO

Did all bottles arrive in good condition (unbroken)? _____ YES NO

Were all bottle labels complete and legible? _____ YES NO

Did the number of containers listed on COC match with the number of containers received? _____ YES NO

Did all bottle labels and tags agree with custody papers? _____ YES NO

Were all bottles used correct for the requested analyses? _____ YES NO

Do any of the analyses (bottles) require preservation? (attach preservation sheet, excluding VOCs) ... (NA) YES NO

Were all VOC vials free of air bubbles? (NA) YES NO

Was sufficient amount of sample sent in each bottle? _____ YES NO

Date VOC Trip Blank was made at ARI: _____ (NA)

Was Sample Split by ARI: (NA) YES Date/Time: _____ Equipment: _____ Split by: _____

Samples Logged by: JM Date: 8/28/13 Time: 1454

**** Notify Project Manager of discrepancies or concerns ****

Sample ID on Bottle	Sample ID on COC	Sample ID on Bottle	Sample ID on COC

Additional Notes, Discrepancies, & Resolutions:

By: _____ Date: _____

<p>Small Air Bubbles - 2mm</p>	<p>Peabubbles 2-4 mm</p>	<p>LARGE Air Bubbles > 4 mm</p>	<p>Small → "sm"</p> <p>Peabubbles → "pb"</p> <p>Large → "lg"</p> <p>Headspace → "hs"</p>
------------------------------------	------------------------------	--	--



Cooler Temperature Compliance Form

XCL60

Cooler#:	<u>1</u>	Temperature(°C):	<u>6.6</u>
Sample ID	Bottle Count	Bottle Type	
SPL-1-20130827	1	802	WNG
SPL-2-20130827	1	802	WME

Cooler#:		Temperature(°C):	
Sample ID	Bottle Count	Bottle Type	

Cooler#:		Temperature(°C):	
Sample ID	Bottle Count	Bottle Type	

Cooler#:		Temperature(°C):	
Sample ID	Bottle Count	Bottle Type	

Completed by: JM Date: 8/28/13 Time: 1455

Sample ID Cross Reference Report



ARI Job No: XC60
Client: Landau Associates, Inc.
Project Event: 118033.100.104
Project Name: Kaiser IA

Sample ID	ARI Lab ID	ARI LIMS ID	Matrix	Sample Date/Time	VTSR
1. SPL-1-20130827	XC60A	13-17914	Soil	08/27/13 12:01	08/28/13 12:32
2. SPL-2-20130827	XC60B	13-17915	Soil	08/27/13 12:15	08/28/13 12:32

ORGANICS ANALYSIS DATA SHEET

PNAs by SW8270D GC/MS

Page 1 of 1

**Sample ID: SPL-1-20130827
SAMPLE**

Lab Sample ID: XC60A

LIMS ID: 13-17914

Matrix: Soil

Data Release Authorized: *[Signature]*

Reported: 08/29/13

QC Report No: XC60-Landau Associates, Inc.

Project: Kaiser IA

118033.100.104

Date Sampled: 08/27/13

Date Received: 08/28/13

Date Extracted: 08/29/13

Date Analyzed: 08/29/13 16:05

Instrument/Analyst: NT6/JZ

GPC Cleanup: No

Alumina: No

Silica Gel: No

Sample Amount: 8.23 g-dry-wt

Final Extract Volume: 0.5 mL

Dilution Factor: 1.00

Percent Moisture: 15.0%

CAS Number	Analyte	RL	Result
56-55-3	Benzo(a)anthracene	61	< 61 U
218-01-9	Chrysene	61	< 61 U
50-32-8	Benzo(a)pyrene	61	< 61 U
193-39-5	Indeno(1,2,3-cd)pyrene	61	< 61 U
53-70-3	Dibenz(a,h)anthracene	61	< 61 U
TOTBFA	Total Benzofluoranthenes	61	< 61 U

Reported in µg/kg (ppb)

Semivolatile Surrogate Recovery

d14-p-Terphenyl	90.4%
2-Fluorobiphenyl	69.6%

ORGANICS ANALYSIS DATA SHEET

PNAs by SW8270D GC/MS

Page 1 of 1



Sample ID: SPL-2-20130827
SAMPLE

Lab Sample ID: XC60B

LIMS ID: 13-17915

Matrix: Soil

Data Release Authorized: *[Signature]*

Reported: 08/29/13

QC Report No: XC60-Landau Associates, Inc.

Project: Kaiser IA

118033.100.104

Date Sampled: 08/27/13

Date Received: 08/28/13

Date Extracted: 08/29/13

Date Analyzed: 08/29/13 16:39

Instrument/Analyst: NT6/JZ

GPC Cleanup: No

Alumina: No

Silica Gel: No

Sample Amount: 8.82 g-dry-wt

Final Extract Volume: 0.5 mL

Dilution Factor: 1.00

Percent Moisture: 8.4%

CAS Number	Analyte	RL	Result
56-55-3	Benzo(a)anthracene	57	< 57 U
218-01-9	Chrysene	57	< 57 U
50-32-8	Benzo(a)pyrene	57	< 57 U
193-39-5	Indeno(1,2,3-cd)pyrene	57	< 57 U
53-70-3	Dibenz(a,h)anthracene	57	< 57 U
TOTBFA	Total Benzofluoranthenes	57	< 57 U

Reported in µg/kg (ppb)

Semivolatile Surrogate Recovery

d14-p-Terphenyl	86.0%
2-Fluorobiphenyl	71.6%

ORGANICS ANALYSIS DATA SHEET

PNAs by SW8270D GC/MS

Page 1 of 1

Sample ID: MB-082913

METHOD BLANK

Lab Sample ID: MB-082913

LIMS ID: 13-17914

Matrix: Soil

Data Release Authorized:

Reported: 08/29/13

QC Report No: XC60-Landau Associates, Inc.

Project: Kaiser IA

118033.100.104

Date Sampled: NA

Date Received: NA

Date Extracted: 08/29/13

Date Analyzed: 08/29/13 14:23

Instrument/Analyst: NT6/JZ

GPC Cleanup: No

Alumina: No

Silica Gel: No

Sample Amount: 7.50 g-dry-wt

Final Extract Volume: 0.5 mL

Dilution Factor: 1.00

Percent Moisture: NA

CAS Number	Analyte	RL	Result
56-55-3	Benzo(a)anthracene	67	< 67 U
218-01-9	Chrysene	67	< 67 U
50-32-8	Benzo(a)pyrene	67	< 67 U
193-39-5	Indeno(1,2,3-cd)pyrene	67	< 67 U
53-70-3	Dibenz(a,h)anthracene	67	< 67 U
TOTBFA	Total Benzofluoranthenes	67	< 67 U

Reported in µg/kg (ppb)

Semivolatile Surrogate Recovery

d14-p-Terphenyl	96.4%
2-Fluorobiphenyl	64.8%

SW8270 PNA SURROGATE RECOVERY SUMMARY



Matrix: Soil

QC Report No: XC60-Landau Associates, Inc.
Project: Kaiser IA
118033.100.104

<u>Client ID</u>	<u>TER</u>	<u>FBP</u>	<u>TOT OUT</u>
MB-082913	96.4%	64.8%	0
LCS-082913	94.8%	75.6%	0
LCSD-082913	87.2%	65.6%	0
SPL-1-20130827	90.4%	69.6%	0
SPL-2-20130827	86.0%	71.6%	0

	<u>LCS/MB LIMITS</u>	<u>QC LIMITS</u>
(TER) = d14-p-Terphenyl	(30-160)	(30-160)
(FBP) = 2-Fluorobiphenyl	(30-160)	(30-160)

Prep Method: SW3546
Log Number Range: 13-17914 to 13-17915

ORGANICS ANALYSIS DATA SHEET

PNA's by SW8270D GC/MS

Page 1 of 1

Sample ID: LCS-082913

LCS/LCSD

Lab Sample ID: LCS-082913

LIMS ID: 13-17914

Matrix: Soil

Data Release Authorized: 

Reported: 08/29/13

QC Report No: XC60-Landau Associates, Inc.

Project: Kaiser IA

118033.100.104

Date Sampled: NA

Date Received: 08/28/13

Date Extracted LCS/LCSD: 08/29/13

Sample Amount LCS: 7.50 g-dry-wt

LCSD: 7.50 g-dry-wt

Date Analyzed LCS: 08/29/13 14:57

Final Extract Volume LCS: 0.50 mL

LCSD: 08/29/13 15:31

LCSD: 0.50 mL

Instrument/Analyst LCS: NT6/JZ

Dilution Factor LCS: 1.00

LCSD: NT6/JZ

LCSD: 1.00

GPC Cleanup: No

Alumina Cleanup: No

Silica Gel Cleanup: No

Analyte	Spike		LCS		Spike		LCSD	
	LCS	Added-LCS	Recovery	LCSD	Added-LCSD	Recovery	RPD	
Benzo(a)anthracene	1420	1670	85.0%	1370	1670	82.0%	3.6%	
Chrysene	1420	1670	85.0%	1380	1670	82.6%	2.9%	
Benzo(a)pyrene	1410	1670	84.4%	1370	1670	82.0%	2.9%	
Indeno(1,2,3-cd)pyrene	1400	1670	83.8%	1350	1670	80.8%	3.6%	
Dibenz(a,h)anthracene	1400	1670	83.8%	1360	1670	81.4%	2.9%	
Total Benzofluoranthenes	3200	3330	96.1%	3140	3330	94.3%	1.9%	

Semivolatile Surrogate Recovery

	LCS	LCSD
d14-p-Terphenyl	94.8%	87.2%
2-Fluorobiphenyl	75.6%	65.6%

Results reported in µg/kg

RPD calculated using sample concentrations per SW846.



Analytical Resources, Incorporated
Analytical Chemists and Consultants

September 3, 2013

Jessica Stone
Landau Associates, Inc.
950 Pacific Ave # 515
Tacoma, WA 98402

RE: Project: Kaiser IA
ARI Job No: XC78

Dear Jessica:

Please find enclosed the original Chain-of-Custody (COC) record, sample receipt documentation, and the analytical results for the samples from the projects referenced above. Analytical Resources, Inc. (ARI) accepted two soil samples on August 29, 2013 in good condition. For further details regarding sample receipt, please refer to the enclosed Cooler Receipt Form.

The samples were analyzed for cPAHs, as requested on the COC.

No analytical complications were noted.

An electronic copy of this report and all associated raw data will remain on file with ARI. If you have any questions or require additional information, please feel free to contact me at your convenience.

Sincerely,
ANALYTICAL RESOURCES, INC.

A handwritten signature in black ink, appearing to read 'Kelly Bottem'.

Kelly Bottem
Client Services Manager
206/695-6211
kellyb@arilabs.com

Enclosures



Cooler Receipt Form

ARI Client Lanlan

Project Name Kaiser IA

COC No(s): _____ NA

Delivered by: Fed-Ex UPS Courier Hand Delivered Other: _____

Assigned ARI Job No X018

Tracking No. _____ NA

Preliminary Examination Phase:

Were intact, properly signed and dated custody seals attached to the outside of to cooler? YES NO

Were custody papers included with the cooler? YES YES NO

Were custody papers properly filled out (ink, signed, etc.)? YES YES NO

Temperature of Cooler(s) (°C) (recommended 2 0-6 0 °C for chemistry) _____ 3.3

If cooler temperature is out of compliance fill out form 00070F

Cooler Accepted by: [Signature] Date 8/29/13 Time 1102 Temp Gun ID#: 122412224

Complete custody forms and attach all shipping documents

Log-In Phase:

Was a temperature blank included in the cooler? YES NO

What kind of packing material was used? ... Bubble Wrap Wet Ice Gel Packs Baggies Foam Block Paper Other: _____

Was sufficient ice used (if appropriate)? NA YES YES NO NO

Were all bottles sealed in individual plastic bags? YES YES NO NO

Did all bottles arrive in good condition (unbroken)? YES YES NO

Were all bottle labels complete and legible? YES YES NO

Did the number of containers listed on COC match with the number of containers received? YES YES NO

Did all bottle labels and tags agree with custody papers? YES YES NO

Were all bottles used correct for the requested analyses? YES YES NO

Do any of the analyses (bottles) require preservation? (attach preservation sheet, excluding VOCs)... NA YES NO

Were all VOC vials free of air bubbles? NA YES NO

Was sufficient amount of sample sent in each bottle? YES YES NO

Date VOC Trip Blank was made at ARI: NA

Was Sample Split by ARI: NA YES Date/Time: _____ Equipment: _____ Split by: _____

Samples Logged by: [Signature] Date: 8-29-13 Time: 1236

**** Notify Project Manager of discrepancies or concerns ****

Sample ID on Bottle	Sample ID on COC	Sample ID on Bottle	Sample ID on COC

Additional Notes, Discrepancies, & Resolutions:

By: _____ Date: _____

			Small → "sm"
			Peabubbles → "pb"
			Large → "lg"
			Headspace → "hs"

Sample ID Cross Reference Report



ARI Job No: XC78
Client: Landau Associates, Inc.
Project Event: 118033.100.104
Project Name: Kaiser IA

Sample ID	ARI Lab ID	ARI LIMS ID	Matrix	Sample Date/Time	VTSR
1. SPL-3-20130829	XC78A	13-18029	Soil	08/29/13 10:00	08/29/13 11:02
2. SPL-4-20130829	XC78B	13-18030	Soil	08/29/13 10:10	08/29/13 11:02

ORGANICS ANALYSIS DATA SHEET

PNAs by SW8270D GC/MS

Page 1 of 1

Sample ID: SPL-3-20130829

SAMPLE

Lab Sample ID: XC78A

LIMS ID: 13-18029

Matrix: Soil

Data Release Authorized: 

Reported: 09/03/13

QC Report No: XC78-Landau Associates, Inc.

Project: Kaiser IA

118033.100.104

Date Sampled: 08/29/13

Date Received: 08/29/13

Date Extracted: 08/30/13

Date Analyzed: 08/30/13 22:08

Instrument/Analyst: NT6/JZ

GPC Cleanup: No

Alumina: No

Silica Gel: No

Sample Amount: 8.19 g-dry-wt

Final Extract Volume: 0.5 mL

Dilution Factor: 1.00

Percent Moisture: 9.2%

CAS Number	Analyte	RL	Result
56-55-3	Benzo(a)anthracene	61	< 61 U
218-01-9	Chrysene	61	< 61 U
50-32-8	Benzo(a)pyrene	61	< 61 U
193-39-5	Indeno(1,2,3-cd)pyrene	61	< 61 U
53-70-3	Dibenz(a,h)anthracene	61	< 61 U
TOTBFA	Total Benzofluoranthenes	61	< 61 U

Reported in µg/kg (ppb)

Semivolatile Surrogate Recovery

d14-p-Terphenyl	87.6%
2-Fluorobiphenyl	73.2%

ORGANICS ANALYSIS DATA SHEET

PNAs by SW8270D GC/MS

Page 1 of 1

Sample ID: SPL-4-20130829

SAMPLE

Lab Sample ID: XC78B

LIMS ID: 13-18030

Matrix: Soil

Data Release Authorized: *[Signature]*

Reported: 09/03/13

QC Report No: XC78-Landau Associates, Inc.

Project: Kaiser IA

118033.100.104

Date Sampled: 08/29/13

Date Received: 08/29/13

Date Extracted: 08/30/13

Date Analyzed: 08/30/13 22:42

Instrument/Analyst: NT6/JZ

GPC Cleanup: No

Alumina: No

Silica Gel: No

Sample Amount: 8.40 g-dry-wt

Final Extract Volume: 0.5 mL

Dilution Factor: 1.00

Percent Moisture: 6.8%

CAS Number	Analyte	RL	Result
56-55-3	Benzo(a)anthracene	60	< 60 U
218-01-9	Chrysene	60	< 60 U
50-32-8	Benzo(a)pyrene	60	< 60 U
193-39-5	Indeno(1,2,3-cd)pyrene	60	< 60 U
53-70-3	Dibenz(a,h)anthracene	60	< 60 U
TOTBFA	Total Benzofluoranthenes	60	< 60 U

Reported in µg/kg (ppb)

Semivolatile Surrogate Recovery

d14-p-Terphenyl	82.8%
2-Fluorobiphenyl	64.4%

ORGANICS ANALYSIS DATA SHEET

PNA's by SW8270D GC/MS

Page 1 of 1

Sample ID: SPL-4-20130829

MATRIX SPIKE

Lab Sample ID: XC78B

LIMS ID: 13-18030

Matrix: Soil

Data Release Authorized: *B*

Reported: 09/03/13

QC Report No: XC78-Landau Associates, Inc.

Project: Kaiser IA

118033.100.104

Date Sampled: 08/29/13

Date Received: 08/29/13

Date Extracted: 08/30/13

Date Analyzed: 08/30/13 23:16

Instrument/Analyst: NT6/JZ

GPC Cleanup: No

Alumina: No

Silica Gel: No

Sample Amount: 8.41 g-dry-wt

Final Extract Volume: 0.5 mL

Dilution Factor: 1.00

Percent Moisture: 6.8%

CAS Number	Analyte	RL	Result
56-55-3	Benzo(a)anthracene	60	---
218-01-9	Chrysene	60	---
50-32-8	Benzo(a)pyrene	60	---
193-39-5	Indeno(1,2,3-cd)pyrene	60	---
53-70-3	Dibenz(a,h)anthracene	60	---
TOTBFA	Total Benzofluoranthenes	60	---

Reported in µg/kg (ppb)

Semivolatile Surrogate Recovery

d14-p-Terphenyl	78.8%
2-Fluorobiphenyl	67.6%

ORGANICS ANALYSIS DATA SHEET

PNA's by SW8270D GC/MS

Page 1 of 1

Sample ID: SPL-4-20130829

MATRIX SPIKE DUPLICATE

Lab Sample ID: XC78B

LIMS ID: 13-18030

Matrix: Soil

Data Release Authorized: *B*

Reported: 09/03/13

QC Report No: XC78-Landau Associates, Inc.

Project: Kaiser IA

118033.100.104

Date Sampled: 08/29/13

Date Received: 08/29/13

Date Extracted: 08/30/13

Date Analyzed: 08/30/13 23:50

Instrument/Analyst: NT6/JZ

GPC Cleanup: No

Alumina: No

Silica Gel: No

Sample Amount: 8.43 g-dry-wt

Final Extract Volume: 0.5 mL

Dilution Factor: 1.00

Percent Moisture: 6.8%

CAS Number	Analyte	RL	Result
56-55-3	Benzo(a)anthracene	59	---
218-01-9	Chrysene	59	---
50-32-8	Benzo(a)pyrene	59	---
193-39-5	Indeno(1,2,3-cd)pyrene	59	---
53-70-3	Dibenz(a,h)anthracene	59	---
TOTBFA	Total Benzofluoranthenes	59	---

Reported in µg/kg (ppb)

Semivolatile Surrogate Recovery

d14-p-Terphenyl	79.6%
2-Fluorobiphenyl	64.8%

ORGANICS ANALYSIS DATA SHEET

PNAs by SW8270D GC/MS

Page 1 of 1



Sample ID: MB-083013

METHOD BLANK

Lab Sample ID: MB-083013

LIMS ID: 13-18030

Matrix: Soil

Data Release Authorized:

Reported: 09/03/13

QC Report No: XC78-Landau Associates, Inc.

Project: Kaiser IA

118033.100.104

Date Sampled: NA

Date Received: NA

Date Extracted: 08/30/13

Date Analyzed: 08/30/13 20:27

Instrument/Analyst: NT6/JZ

GPC Cleanup: No

Alumina: No

Silica Gel: No

Sample Amount: 7.50 g-dry-wt

Final Extract Volume: 0.5 mL

Dilution Factor: 1.00

Percent Moisture: NA

CAS Number	Analyte	RL	Result
56-55-3	Benzo(a)anthracene	67	< 67 U
218-01-9	Chrysene	67	< 67 U
50-32-8	Benzo(a)pyrene	67	< 67 U
193-39-5	Indeno(1,2,3-cd)pyrene	67	< 67 U
53-70-3	Dibenz(a,h)anthracene	67	< 67 U
TOTBFA	Total Benzofluoranthenes	67	< 67 U

Reported in µg/kg (ppb)

Semivolatile Surrogate Recovery

d14-p-Terphenyl	86.4%
2-Fluorobiphenyl	74.0%

SW8270 PNA SURROGATE RECOVERY SUMMARY



Matrix: Soil

QC Report No: XC78-Landau Associates, Inc.
Project: Kaiser IA
118033.100.104

<u>Client ID</u>	<u>TER</u>	<u>FBP</u>	<u>TOT OUT</u>
SPL-3-20130829	87.6%	73.2%	0
MB-083013	86.4%	74.0%	0
LCS-083013	84.4%	70.4%	0
LCSD-083013	77.6%	64.8%	0
SPL-4-20130829	82.8%	64.4%	0
SPL-4-20130829 MS	78.8%	67.6%	0
SPL-4-20130829 MSD	79.6%	64.8%	0

	<u>LCS/MB LIMITS</u>	<u>QC LIMITS</u>
(TER) = d14-p-Terphenyl	(30-160)	(30-160)
(FBP) = 2-Fluorobiphenyl	(30-160)	(30-160)

Prep Method: SW3546
Log Number Range: 13-18029 to 13-18030

ORGANICS ANALYSIS DATA SHEET

PNAs by SW8270D GC/MS

Page 1 of 1

Sample ID: SPL-4-20130829

MS/MSD

Lab Sample ID: XC78B

LIMS ID: 13-18030

Matrix: Soil

Data Release Authorized: 

Reported: 09/03/13

QC Report No: XC78-Landau Associates, Inc.

Project: Kaiser IA

118033.100.104

Date Sampled: 08/29/13

Date Received: 08/29/13

Date Extracted MS/MSD: 08/30/13

Sample Amount MS: 8.41 g-dry-wt

MSD: 8.43 g-dry-wt

Date Analyzed MS: 08/30/13 23:16

Final Extract Volume MS: 0.5 mL

MSD: 08/30/13 23:50

MSD: 0.5 mL

Instrument/Analyst MS: NT6/JZ

Dilution Factor MS: 1.00

MSD: NT6/JZ

MSD: 1.00

GPC Cleanup: No

Alumina Cleanup: No

Silica Gel Cleanup: No

Analyte	Sample	MS	Spike Added-MS	MS Recovery	MSD	Spike Added-MSD	MSD Recovery	RPD
Benzo(a)anthracene	< 60	1170	1490	78.5%	1210	1480	81.8%	3.4%
Chrysene	< 60	1160	1490	77.9%	1230	1480	83.1%	5.9%
Benzo(a)pyrene	< 60	1170	1490	78.5%	1240	1480	83.8%	5.8%
Indeno(1,2,3-cd)pyrene	< 60	1210	1490	81.2%	1250	1480	84.5%	3.3%
Dibenz(a,h)anthracene	< 60	1180	1490	79.2%	1260	1480	85.1%	6.6%
Total Benzofluoranthenes	< 60	2540	2970	85.5%	2690	2970	90.6%	5.7%

Results reported in µg/kg

RPD calculated using sample concentrations per SW846.

ORGANICS ANALYSIS DATA SHEET

PNAs by SW8270D GC/MS

Page 1 of 1

Sample ID: LCS-083013

LCS/LCSD

Lab Sample ID: LCS-083013

LIMS ID: 13-18030

Matrix: Soil

Data Release Authorized: *CB*

Reported: 09/03/13

QC Report No: XC78-Landau Associates, Inc.

Project: Kaiser IA

118033.100.104

Date Sampled: NA

Date Received: 08/29/13

Date Extracted LCS/LCSD: 08/30/13

Sample Amount LCS: 7.50 g-dry-wt

LCSD: 7.50 g-dry-wt

Date Analyzed LCS: 08/30/13 21:01

Final Extract Volume LCS: 0.50 mL

LCSD: 08/30/13 21:35

LCSD: 0.50 mL

Instrument/Analyst LCS: NT6/JZ

Dilution Factor LCS: 1.00

LCSD: NT6/JZ

LCSD: 1.00

GPC Cleanup: No

Alumina Cleanup: No

Silica Gel Cleanup: No

Analyte	Spike		LCS		Spike		LCSD	
	LCS	Added-LCS	Recovery	LCS	Added-LCSD	Recovery	RPD	
Benzo(a)anthracene	1400	1670	83.8%	1330	1670	79.6%	5.1%	
Chrysene	1390	1670	83.2%	1350	1670	80.8%	2.9%	
Benzo(a)pyrene	1380	1670	82.6%	1340	1670	80.2%	2.9%	
Indeno(1,2,3-cd)pyrene	1410	1670	84.4%	1380	1670	82.6%	2.2%	
Dibenz(a,h)anthracene	1420	1670	85.0%	1370	1670	82.0%	3.6%	
Total Benzofluoranthenes	2990	3330	89.8%	2920	3330	87.7%	2.4%	

Semivolatile Surrogate Recovery

	LCS	LCSD
d14-p-Terphenyl	84.4%	77.6%
2-Fluorobiphenyl	70.4%	64.8%

Results reported in µg/kg

RPD calculated using sample concentrations per SW846.



Analytical Resources, Incorporated
Analytical Chemists and Consultants

September 5, 2013

Jessica Stone
Landau Associates, Inc.
950 Pacific Ave # 515
Tacoma, WA 98402

RE: Project: Kaiser IA
ARI Job No: XD32

Dear Jessica:

Please find enclosed the original Chain-of-Custody (COC) record, sample receipt documentation, and the analytical results for the samples from the projects referenced above. Analytical Resources, Inc. (ARI) accepted two soil samples on September 3, 2013 in good condition. For further details regarding sample receipt, please refer to the enclosed Cooler Receipt Form.

The samples were analyzed for cPAHs, as requested on the COC.

No analytical complications were noted.

An electronic copy of this report and all associated raw data will remain on file with ARI. If you have any questions or require additional information, please feel free to contact me at your convenience.

Sincerely,
ANALYTICAL RESOURCES, INC.

Kelly Bottem
Client Services Manager
206/695-6211
kellyb@arilabs.com

Enclosures

- Seattle/Edmonds (425) 778-0907
- Tacoma (253) 926-2493
- Spokane (509) 327-9737
- Portland (503) 542-1080



Chain-of-Custody Record

Date 9/3/2013
Page 1 of 1

Project Name	Project No.	Testing Parameters				Turnaround Time			
<u>Kaiser IA</u>	<u>118033100104</u>	CPAH - 8270D				<input type="checkbox"/> Standard <input type="checkbox"/> Accelerated <input checked="" type="checkbox"/> <u>1-2 day</u>			
Project Location/Event	Sampler's Name	Project Contact	Send Results To	Sample I.D.	Date	Time	Matrix	No. of Containers	Observations/Comments
<u>Port of Tacoma</u>	<u>DAR, DAM</u>	<u>Dave Pischer</u>	<u>Jess Strong</u>	<u>SPL-5-20130903</u>	<u>9/3/13</u>	<u>1000</u>	<u>Soil</u>	<u>1</u>	<u>X</u> Allow water samples to settle, collect aliquot from clear portion <u>X</u> NWTPH-Dx - run acid wash/silica gel cleanup ___ run samples standardized to ___ product ___ Analyze for EPH if no specific product identified VOC/BTEX/VPH (soil): ___ non-preserved ___ preserved w/methanol ___ preserved w/sodium bisulfate ___ Freeze upon receipt ___ Dissolved metal water samples field filtered Other: ___
				<u>SPL-6-20130903</u>	<u>9/8/13</u>	<u>1010</u>	<u>Soil</u>	<u>1</u>	
Special Shipment/Handling or Storage Requirements: <u>ICE</u>									
Relinquished by Signature: <u>[Signature]</u> Printed Name: <u>Don Makkemus</u> Company: <u>LAI</u> Date: <u>9/3/13</u> Time: <u>1335</u>		Received by Signature: <u>[Signature]</u> Printed Name: <u>Rich Hudson</u> Company: <u>ARI</u> Date: <u>9/3/13</u> Time: <u>1335</u>		Relinquished by Signature: _____ Printed Name: _____ Company: _____ Date: _____ Time: _____		Received by Signature: _____ Printed Name: _____ Company: _____ Date: _____ Time: _____		Method of Shipment: <u>Carrier</u>	

Sample ID Cross Reference Report



ARI Job No: XD32
Client: Landau Associates, Inc.
Project Event: 118033.100.104
Project Name: Kaiser IA

Sample ID	ARI Lab ID	ARI LIMS ID	Matrix	Sample Date/Time	VTSR
1. SPL-5-20130903	XD32A	13-18341	Soil	09/03/13 10:00	09/03/13 13:35
2. SPL-6-20130903	XD32B	13-18342	Soil	09/03/13 10:10	09/03/13 13:35



Cooler Receipt Form

ARI Client Kaiser
COC No(s) _____ NA
Assigned ARI Job No X032

Project Name: Kaiser BA
Delivered by Fed-Ex UPS Courier Hand Delivered Other _____
Tracking No _____ NA

Preliminary Examination Phase:

Were intact, properly signed and dated custody seals attached to the outside of to cooler? YES NO
 Were custody papers included with the cooler? YES NO
 Were custody papers properly filled out (ink, signed, etc.) YES NO
 Temperature of Cooler(s) (°C) (recommended 2 0-6.0 °C for chemistry) _____
 If cooler temperature is out of compliance fill out form 00070F _____
 Cooler Accepted by: _____ Date: 9/3/13 Time: 1335 Temp Gun ID#: 122412224

Complete custody forms and attach all shipping documents

Log-In Phase:

Was a temperature blank included in the cooler? YES NO
 What kind of packing material was used? ... Bubble Wrap Wet Ice Gel Packs Baggies Foam Block Paper Other: _____
 Was sufficient ice used (if appropriate)? NA YES NO
 Were all bottles sealed in individual plastic bags? YES NO
 Did all bottles arrive in good condition (unbroken)? YES NO
 Were all bottle labels complete and legible? YES NO
 Did the number of containers listed on COC match with the number of containers received? YES NO
 Did all bottle labels and tags agree with custody papers? YES NO
 Were all bottles used correct for the requested analyses? YES NO
 Do any of the analyses (bottles) require preservation? (attach preservation sheet, excluding VOCs) NA YES NO
 Were all VOC vials free of air bubbles? NA YES NO
 Was sufficient amount of sample sent in each bottle? YES NO
 Date VOC Trip Blank was made at ARI: _____ NA
 Was Sample Split by ARI: NA YES Date/Time: _____ Equipment: _____ Split by: _____
 Samples Logged by: TJ Date: 9-3-13 Time: 1427

**** Notify Project Manager of discrepancies or concerns ****

Sample ID on Bottle	Sample ID on COC	Sample ID on Bottle	Sample ID on COC

Additional Notes, Discrepancies, & Resolutions:

By: _____ Date: _____

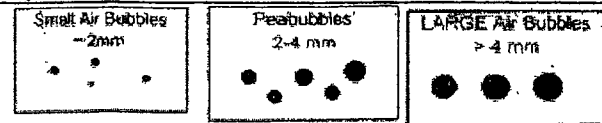

Small → "sm"
Peabubbles → "pb"
Large → "lg"
Headspace → "hs"

ORGANICS ANALYSIS DATA SHEET

PNAs by SW8270D GC/MS

Page 1 of 1

Sample ID: SPL-5-20130903

SAMPLE

Lab Sample ID: XD32A

LIMS ID: 13-18341

Matrix: Soil

Data Release Authorized: 

Reported: 09/05/13

QC Report No: XD32-Landau Associates, Inc.

Project: Kaiser IA

118033.100.104

Date Sampled: 09/03/13

Date Received: 09/03/13

Date Extracted: 09/04/13

Date Analyzed: 09/04/13 20:16

Instrument/Analyst: NT6/JZ

GPC Cleanup: No

Alumina: No

Silica Gel: Yes

Sample Amount: 7.66 g-dry-wt

Final Extract Volume: 0.5 mL

Dilution Factor: 1.00

Percent Moisture: 15.1%

CAS Number	Analyte	RL	Result
56-55-3	Benzo(a)anthracene	65	< 65 U
218-01-9	Chrysene	65	73
50-32-8	Benzo(a)pyrene	65	< 65 U
193-39-5	Indeno(1,2,3-cd)pyrene	65	< 65 U
53-70-3	Dibenz(a,h)anthracene	65	< 65 U
TOTBFA	Total Benzofluoranthenes	65	110

Reported in µg/kg (ppb)

Semivolatile Surrogate Recovery

d14-p-Terphenyl	88.0%
2-Fluorobiphenyl	58.8%

ORGANICS ANALYSIS DATA SHEET

PNAs by SW8270D GC/MS

Page 1 of 1

Sample ID: SPL-6-20130903

SAMPLE

Lab Sample ID: XD32B

LIMS ID: 13-18342

Matrix: Soil

Data Release Authorized: 

Reported: 09/05/13

QC Report No: XD32-Landau Associates, Inc.

Project: Kaiser IA

118033.100.104

Date Sampled: 09/03/13

Date Received: 09/03/13

Date Extracted: 09/04/13

Date Analyzed: 09/04/13 20:50

Instrument/Analyst: NT6/JZ

GPC Cleanup: No

Alumina: No

Silica Gel: Yes

Sample Amount: 8.19 g-dry-wt

Final Extract Volume: 0.5 mL

Dilution Factor: 1.00

Percent Moisture: 18.1%

CAS Number	Analyte	RL	Result
56-55-3	Benzo(a)anthracene	61	< 61 U
218-01-9	Chrysene	61	< 61 U
50-32-8	Benzo(a)pyrene	61	< 61 U
193-39-5	Indeno(1,2,3-cd)pyrene	61	< 61 U
53-70-3	Dibenz(a,h)anthracene	61	< 61 U
TOTBFA	Total Benzofluoranthenes	61	< 61 U

Reported in µg/kg (ppb)

Semivolatile Surrogate Recovery

d14-p-Terphenyl	81.2%
2-Fluorobiphenyl	57.6%

ORGANICS ANALYSIS DATA SHEET

PNAs by SW8270D GC/MS

Page 1 of 1

Sample ID: MB-090413

METHOD BLANK

Lab Sample ID: MB-090413

LIMS ID: 13-18341

Matrix: Soil

Data Release Authorized: *AB*

Reported: 09/05/13

QC Report No: XD32-Landau Associates, Inc.

Project: Kaiser IA

118033.100.104

Date Sampled: NA

Date Received: NA

Date Extracted: 09/04/13

Date Analyzed: 09/04/13 18:34

Instrument/Analyst: NT6/JZ

GPC Cleanup: No

Alumina: No

Silica Gel: Yes

Sample Amount: 7.50 g-dry-wt

Final Extract Volume: 0.5 mL

Dilution Factor: 1.00

Percent Moisture: NA

CAS Number	Analyte	RL	Result
56-55-3	Benzo(a)anthracene	67	< 67 U
218-01-9	Chrysene	67	< 67 U
50-32-8	Benzo(a)pyrene	67	< 67 U
193-39-5	Indeno(1,2,3-cd)pyrene	67	< 67 U
53-70-3	Dibenz(a,h)anthracene	67	< 67 U
TOTBFA	Total Benzofluoranthenes	67	< 67 U

Reported in µg/kg (ppb)

Semivolatile Surrogate Recovery

d14-p-Terphenyl	96.0%
2-Fluorobiphenyl	62.0%

SW8270 PNA SURROGATE RECOVERY SUMMARY

Matrix: Soil

QC Report No: XD32-Landau Associates, Inc.
Project: Kaiser IA
118033.100.104

<u>Client ID</u>	<u>TER</u>	<u>FBP</u>	<u>TOT OUT</u>
MB-090413	96.0%	62.0%	0
LCS-090413	90.0%	59.2%	0
LCSD-090413	88.8%	55.2%	0
SPL-5-20130903	88.0%	58.8%	0
SPL-6-20130903	81.2%	57.6%	0

LCS/MB LIMITS QC LIMITS

(TER) = d14-p-Terphenyl (30-160) (30-160)
(FBP) = 2-Fluorobiphenyl (30-160) (30-160)

Prep Method: SW3546
Log Number Range: 13-18341 to 13-18342

ORGANICS ANALYSIS DATA SHEET

PNA's by SW8270D GC/MS

Page 1 of 1

Sample ID: LCS-090413

LCS/LCSD

Lab Sample ID: LCS-090413

LIMS ID: 13-18341

Matrix: Soil

Data Release Authorized: *[Signature]*

Reported: 09/05/13

QC Report No: XD32-Landau Associates, Inc.

Project: Kaiser IA

118033.100.104

Date Sampled: NA

Date Received: 09/03/13

Date Extracted LCS/LCSD: 09/04/13

Sample Amount LCS: 7.50 g-dry-wt

LCSD: 7.50 g-dry-wt

Date Analyzed LCS: 09/04/13 19:08

Final Extract Volume LCS: 0.50 mL

LCSD: 09/04/13 19:42

LCSD: 0.50 mL

Instrument/Analyst LCS: NT6/JZ

Dilution Factor LCS: 1.00

LCSD: NT6/JZ

LCSD: 1.00

GPC Cleanup: No

Alumina Cleanup: No

Silica Gel Cleanup: Yes

Analyte	Spike		LCS	LCS	Spike		RPD
	LCS	Added-LCS	Recovery		LCS	Added-LCSD	
Benzo(a)anthracene	1370	1670	82.0%	1370	1670	82.0%	0.0%
Chrysene	1450	1670	86.8%	1430	1670	85.6%	1.4%
Benzo(a)pyrene	1360	1670	81.4%	1380	1670	82.6%	1.5%
Indeno(1,2,3-cd)pyrene	1410	1670	84.4%	1420	1670	85.0%	0.7%
Dibenz(a,h)anthracene	1440	1670	86.2%	1460	1670	87.4%	1.4%
Total Benzofluoranthenes	2840	3330	85.3%	2900	3330	87.1%	2.1%

Semivolatile Surrogate Recovery

	LCS	LCSD
d14-p-Terphenyl	90.0%	88.8%
2-Fluorobiphenyl	59.2%	55.2%

Results reported in µg/kg

RPD calculated using sample concentrations per SW846.



Analytical Resources, Incorporated
Analytical Chemists and Consultants

September 9, 2013

Jessica Stone
Landau Associates, Inc.
950 Pacific Ave # 515
Tacoma, WA 98402

RE: Project: Kaiser IA
ARI Job No: XD62

Dear Jessica:

Please find enclosed the original Chain-of-Custody (COC) record, sample receipt documentation, and the analytical results for the samples from the projects referenced above. Analytical Resources, Inc. (ARI) accepted four soil samples on September 5, 2013 in good condition. For further details regarding sample receipt, please refer to the enclosed Cooler Receipt Form.

The samples were analyzed for cPAHs, as requested on the COC.

A matrix spike (MS) and a matrix spike duplicate (MSD) were extracted and analyzed in conjunction with sample SPL-13-20130905. The percent recovery for benzo(a)pyrene was low following the analysis of the MS. The RPD for benzo(a)pyrene was high following the analysis of the MSD. Since the percent recoveries and RPD for benzo(a)pyrene were within acceptable QC limits for the corresponding LCS/LCSD, it was concluded that the sample matrix was the cause of the low percent recovery for the MS and the high RPD for the MSD. No corrective actions were taken.

No further analytical complications were noted.

An electronic copy of this report and all associated raw data will remain on file with ARI. If you have any questions or require additional information, please feel free to contact me at your convenience.

Sincerely,
ANALYTICAL RESOURCES, INC.

Kelly Bottem
Kelly Bottem
Client Services Manager
206/695-6211
kellyb@arilabs.com

Enclosures

- Seattle/Edmonds (425) 778-0907
- Tacoma (253) 926-2493
- Spokane (509) 327-9737
- Portland (503) 542-1080



Chain-of-Custody Record

Date 9/5/2013
Page 1 of 1

Project Name Kaiser IA Project No. 118033.100.104
 Project Location/Event Kaiser, Port of Tacoma
 Sampler's Name DAR / DAM
 Project Contact Dave Fischer
 Send Results To Jess Stone, Sierra Mont, Anna Halverson, Bill Evans, Dave Fischer

Testing Parameters

Turnaround Time
 Standard
 Accelerated
 1-2 Day FAT

CPAH 8270 D

Sample I.D.	Date	Time	Matrix	No. of Containers
SPL-9-20130905	9/5/13	8:47	Soil	1
SPL-10-20130905	9/5/13	8:55	Soil	1
SPL-13-20130905	9/5/13	9:22	Soil	1
SPL-14-20130905	9/5/13	9:35	Soil	1

Observations/Comments

Allow water samples to settle, collect aliquot from clear portion
 NWTPH-Dx - run acid wash/silica gel cleanup
 ___ run samples standardized to ___ product
 ___ Analyze for EPH if no specific product identified
 VOC/BTEX/VPH (soil):
 ___ non-preserved
 ___ preserved w/methanol
 ___ preserved w/sodium bisulfate
 ___ Freeze upon receipt
 ___ Dissolved metal water samples field filtered
 Other _____

Special Shipment/Handling or Storage Requirements Ice

Method of Shipment Courier

Relinquished by
 Signature
 Printed Name Daniel Mathews
 Company LAI
 Date 9/5/13 Time 11:15

Received by
 Signature
 Printed Name Richy Midson
 Company API
 Date 9/5/13 Time 11:15

Relinquished by
 Signature _____
 Printed Name _____
 Company _____
 Date _____ Time _____

Received by
 Signature _____
 Printed Name _____
 Company _____
 Date _____ Time _____

2000 : 000000



Cooler Receipt Form

ARI Client - ardan
COC No(s) _____ NA
Assigned ARI Job No X062

Project Name Kaiser IA
Delivered by: Fed-Ex UPS Courier (circled) Hand Delivered Other _____
Tracking No: _____ NA

Preliminary Examination Phase:

Were intact, properly signed and dated custody seals attached to the outside of to cooler? YES (circled) NO (circled)
 Were custody papers included with the cooler? YES (circled) NO
 Were custody papers properly filled out (ink, signed, etc.) YES (circled) NO
 Temperature of Cooler(s) (°C) (recommended 2 0-6 0 °C for chemistry).....
 If cooler temperature is out of compliance fill out form 00070F
 Cooler Accepted by: [Signature] Date: 9/5/13 Time: 1115 Temp Gun ID# 102412224

Complete custody forms and attach all shipping documents

Log-In Phase:

Was a temperature blank included in the cooler? YES NO
 What kind of packing material was used? ... Bubble Wrap (circled) Wet Ice Gel Packs (circled) Baggies Foam Block Paper Other: _____
 Was sufficient ice used (if appropriate)? NA YES (circled) NO
 Were all bottles sealed in individual plastic bags? YES (circled) NO
 Did all bottles arrive in good condition (unbroken)? YES (circled) NO
 Were all bottle labels complete and legible? YES (circled) NO
 Did the number of containers listed on COC match with the number of containers received? YES (circled) NO
 Did all bottle labels and tags agree with custody papers? YES (circled) NO
 Were all bottles used correct for the requested analyses? YES (circled) NO
 Do any of the analyses (bottles) require preservation? (attach preservation sheet, excluding VOCs) NA YES NO
 Were all VOC vials free of air bubbles? NA YES NO
 Was sufficient amount of sample sent in each bottle? YES (circled) NO
 Date VOC Trip Blank was made at ARI... NA YES NO
 Was Sample Split by ARI: NA YES Date/Time: _____ Equipment: _____ Split by: _____
 Samples Logged by: TS Date: 9.5-13 Time: 1320

**** Notify Project Manager of discrepancies or concerns ****

Sample ID on Bottle	Sample ID on COC	Sample ID on Bottle	Sample ID on COC

Additional Notes, Discrepancies, & Resolutions:

By: _____ Date: _____

			Small → "sm"
			Peabubbles → "pb"
			Large → "lg"
			Headspace → "hs"

Sample ID Cross Reference Report



ARI Job No: XD62
Client: Landau Associates, Inc.
Project Event: 118033.100.104
Project Name: Kaiser IA

Sample ID	ARI Lab ID	ARI LIMS ID	Matrix	Sample Date/Time	VTSR
1. SPL-9-20130905	XD62A	13-18527	Soil	09/05/13 08:47	09/05/13 11:15
2. SPL-10-20130905	XD62B	13-18528	Soil	09/05/13 08:55	09/05/13 11:15
3. SPL-13-20130905	XD62C	13-18529	Soil	09/05/13 09:22	09/05/13 11:15
4. SPL-14-20130905	XD62D	13-18530	Soil	09/05/13 09:35	09/05/13 11:15



Data Reporting Qualifiers

Effective 2/14/2011

Inorganic Data

- U Indicates that the target analyte was not detected at the reported concentration
- * Duplicate RPD is not within established control limits
- B Reported value is less than the CRDL but \geq the Reporting Limit
- N Matrix Spike recovery not within established control limits
- NA Not Applicable, analyte not spiked
- H The natural concentration of the spiked element is so much greater than the concentration spiked that an accurate determination of spike recovery is not possible
- L Analyte concentration is ≤ 5 times the Reporting Limit and the replicate control limit defaults to ± 1 RL instead of the normal 20% RPD

Organic Data

- U Indicates that the target analyte was not detected at the reported concentration
- * Flagged value is not within established control limits
- B Analyte detected in an associated Method Blank at a concentration greater than one-half of ARI's Reporting Limit or 5% of the regulatory limit or 5% of the analyte concentration in the sample.
- J Estimated concentration when the value is less than ARI's established reporting limits
- D The spiked compound was not detected due to sample extract dilution
- E Estimated concentration calculated for an analyte response above the valid instrument calibration range. A dilution is required to obtain an accurate quantification of the analyte.
- Q Indicates a detected analyte with an initial or continuing calibration that does not meet established acceptance criteria ($<20\%$ RSD, $<20\%$ Drift or minimum RRF).



- S Indicates an analyte response that has saturated the detector. The calculated concentration is not valid; a dilution is required to obtain valid quantification of the analyte
- NA The flagged analyte was not analyzed for
- NR Spiked compound recovery is not reported due to chromatographic interference
- NS The flagged analyte was not spiked into the sample
- M Estimated value for an analyte detected and confirmed by an analyst but with low spectral match parameters. This flag is used only for GC-MS analyses
- M2 The sample contains PCB congeners that do not match any standard Aroclor pattern. The PCBs are identified and quantified as the Aroclor whose pattern most closely matches that of the sample. The reported value is an estimate.
- N The analysis indicates the presence of an analyte for which there is presumptive evidence to make a "tentative identification"
- Y The analyte is not detected at or above the reported concentration. The reporting limit is raised due to chromatographic interference. The Y flag is equivalent to the U flag with a raised reporting limit.
- EMPC Estimated Maximum Possible Concentration (EMPC) defined in EPA Statement of Work DLM02.2 as a value "calculated for 2,3,7,8-substituted isomers for which the quantitation and /or confirmation ion(s) has signal to noise in excess of 2.5, but does not meet identification criteria" **(Dioxin/Furan analysis only)**
- C The analyte was positively identified on only one of two chromatographic columns. Chromatographic interference prevented a positive identification on the second column
- P The analyte was detected on both chromatographic columns but the quantified values differ by $\geq 40\%$ RPD with no obvious chromatographic interference
- X Analyte signal includes interference from polychlorinated diphenyl ethers. **(Dioxin/Furan analysis only)**
- Z Analyte signal includes interference from the sample matrix or perfluorokerosene ions. **(Dioxin/Furan analysis only)**



Geotechnical Data

- A The total of all fines fractions. This flag is used to report total fines when only sieve analysis is requested and balances total grain size with sample weight.
- F Samples were frozen prior to particle size determination
- SM Sample matrix was not appropriate for the requested analysis. This normally refers to samples contaminated with an organic product that interferes with the sieving process and/or moisture content, porosity and saturation calculations
- SS Sample did not contain the proportion of "fines" required to perform the pipette portion of the grain size analysis
- W Weight of sample in some pipette aliquots was below the level required for accurate weighting

ORGANICS ANALYSIS DATA SHEET

PNAs by SW8270D GC/MS

Page 1 of 1

Sample ID: SPL-9-20130905

SAMPLE

Lab Sample ID: XD62A

LIMS ID: 13-18527

Matrix: Soil

Data Release Authorized: *[Signature]*

Reported: 09/06/13

QC Report No: XD62-Landau Associates, Inc.

Project: Kaiser IA

118033.100.104

Date Sampled: 09/05/13

Date Received: 09/05/13

Date Extracted: 09/05/13

Date Analyzed: 09/06/13 13:24

Instrument/Analyst: NT6/JZ

GPC Cleanup: No

Alumina: No

Silica Gel: No

Sample Amount: 7.61 g-dry-wt

Final Extract Volume: 0.5 mL

Dilution Factor: 1.00

Percent Moisture: 15.7%

CAS Number	Analyte	RL	Result
56-55-3	Benzo(a)anthracene	66	< 66 U
218-01-9	Chrysene	66	< 66 U
50-32-8	Benzo(a)pyrene	66	< 66 U
193-39-5	Indeno(1,2,3-cd)pyrene	66	< 66 U
53-70-3	Dibenz(a,h)anthracene	66	< 66 U
TOTBFA	Total Benzofluoranthenes	66	< 66 U

Reported in µg/kg (ppb)

Semivolatile Surrogate Recovery

d14-p-Terphenyl	84.0%
2-Fluorobiphenyl	69.6%

ORGANICS ANALYSIS DATA SHEET

PNAs by SW8270D GC/MS

Page 1 of 1

Sample ID: SPL-10-20130905

SAMPLE

Lab Sample ID: XD62B

LIMS ID: 13-18528

Matrix: Soil

Data Release Authorized: 

Reported: 09/06/13

QC Report No: XD62-Landau Associates, Inc.

Project: Kaiser IA

118033.100.104

Date Sampled: 09/05/13

Date Received: 09/05/13

Date Extracted: 09/05/13

Date Analyzed: 09/06/13 13:58

Instrument/Analyst: NT6/JZ

GPC Cleanup: No

Alumina: No

Silica Gel: No

Sample Amount: 7.60 g-dry-wt

Final Extract Volume: 0.5 mL

Dilution Factor: 1.00

Percent Moisture: 15.6%

CAS Number	Analyte	RL	Result
56-55-3	Benzo(a)anthracene	66	< 66 U
218-01-9	Chrysene	66	< 66 U
50-32-8	Benzo(a)pyrene	66	< 66 U
193-39-5	Indeno(1,2,3-cd)pyrene	66	< 66 U
53-70-3	Dibenz(a,h)anthracene	66	< 66 U
TOTBFA	Total Benzofluoranthenes	66	< 66 U

Reported in µg/kg (ppb)

Semivolatile Surrogate Recovery

d14-p-Terphenyl	79.2%
2-Fluorobiphenyl	64.8%

ORGANICS ANALYSIS DATA SHEET

PNAs by SW8270D GC/MS

Page 1 of 1



Sample ID: SPL-13-20130905

SAMPLE

Lab Sample ID: XD62C

LIMS ID: 13-18529

Matrix: Soil

Data Release Authorized: *[Signature]*

Reported: 09/06/13

QC Report No: XD62-Landau Associates, Inc.

Project: Kaiser IA

118033.100.104

Date Sampled: 09/05/13

Date Received: 09/05/13

Date Extracted: 09/05/13

Date Analyzed: 09/06/13 14:32

Instrument/Analyst: NT6/JZ

GPC Cleanup: No

Alumina: No

Silica Gel: No

Sample Amount: 7.77 g-dry-wt

Final Extract Volume: 0.5 mL

Dilution Factor: 1.00

Percent Moisture: 13.9%

CAS Number	Analyte	RL	Result
56-55-3	Benzo(a)anthracene	64	< 64 U
218-01-9	Chrysene	64	< 64 U
50-32-8	Benzo(a)pyrene	64	< 64 U
193-39-5	Indeno(1,2,3-cd)pyrene	64	< 64 U
53-70-3	Dibenz(a,h)anthracene	64	< 64 U
TOTBFA	Total Benzofluoranthenes	64	< 64 U

Reported in µg/kg (ppb)

Semivolatile Surrogate Recovery

d14-p-Terphenyl	89.6%
2-Fluorobiphenyl	74.4%

ORGANICS ANALYSIS DATA SHEET

PNAs by SW8270D GC/MS

Page 1 of 1

Sample ID: SPL-14-20130905

SAMPLE

Lab Sample ID: XD62D

LIMS ID: 13-18530

Matrix: Soil

Data Release Authorized: 

Reported: 09/06/13

QC Report No: XD62-Landau Associates, Inc.

Project: Kaiser IA

118033.100.104

Date Sampled: 09/05/13

Date Received: 09/05/13

Date Extracted: 09/05/13

Date Analyzed: 09/06/13 16:14

Instrument/Analyst: NT6/JZ

GPC Cleanup: No

Alumina: No

Silica Gel: No

Sample Amount: 7.77 g-dry-wt

Final Extract Volume: 0.5 mL

Dilution Factor: 1.00

Percent Moisture: 14.0%

CAS Number	Analyte	RL	Result
56-55-3	Benzo (a) anthracene	64	430
218-01-9	Chrysene	64	710
50-32-8	Benzo (a) pyrene	64	400
193-39-5	Indeno (1,2,3-cd) pyrene	64	340
53-70-3	Dibenz (a,h) anthracene	64	140
TOTBFA	Total Benzofluoranthenes	64	1,000

Reported in µg/kg (ppb)

Semivolatile Surrogate Recovery

d14-p-Terphenyl	79.2%
2-Fluorobiphenyl	67.2%

ORGANICS ANALYSIS DATA SHEET

PNAs by SW8270D GC/MS

Page 1 of 1



Sample ID: SPL-13-20130905

MATRIX SPIKE

Lab Sample ID: XD62C

LIMS ID: 13-18529

Matrix: Soil

Data Release Authorized: *B*

Reported: 09/06/13

QC Report No: XD62-Landau Associates, Inc.

Project: Kaiser IA

118033.100.104

Date Sampled: 09/05/13

Date Received: 09/05/13

Date Extracted: 09/05/13

Date Analyzed: 09/06/13 15:06

Instrument/Analyst: NT6/JZ

GPC Cleanup: No

Alumina: No

Silica Gel: No

Sample Amount: 7.77 g-dry-wt

Final Extract Volume: 0.5 mL

Dilution Factor: 1.00

Percent Moisture: 13.9%

CAS Number	Analyte	RL	Result
56-55-3	Benzo(a)anthracene	64	---
218-01-9	Chrysene	64	---
50-32-8	Benzo(a)pyrene	64	---
193-39-5	Indeno(1,2,3-cd)pyrene	64	---
53-70-3	Dibenz(a,h)anthracene	64	---
TOTBFA	Total Benzofluoranthenes	64	---

Reported in µg/kg (ppb)

Semivolatile Surrogate Recovery

d14-p-Terphenyl	82.8%
2-Fluorobiphenyl	70.0%

ORGANICS ANALYSIS DATA SHEET

PNAs by SW8270D GC/MS

Page 1 of 1



Sample ID: SPL-13-20130905

MATRIX SPIKE DUPLICATE

Lab Sample ID: XD62C

LIMS ID: 13-18529

Matrix: Soil

Data Release Authorized: *AS*

Reported: 09/06/13

QC Report No: XD62-Landau Associates, Inc.

Project: Kaiser IA

118033.100.104

Date Sampled: 09/05/13

Date Received: 09/05/13

Date Extracted: 09/05/13

Date Analyzed: 09/06/13 15:40

Instrument/Analyst: NT6/JZ

GPC Cleanup: No

Alumina: No

Silica Gel: No

Sample Amount: 7.78 g-dry-wt

Final Extract Volume: 0.5 mL

Dilution Factor: 1.00

Percent Moisture: 13.9%

CAS Number	Analyte	RL	Result
56-55-3	Benzo(a)anthracene	64	---
218-01-9	Chrysene	64	---
50-32-8	Benzo(a)pyrene	64	---
193-39-5	Indeno(1,2,3-cd)pyrene	64	---
53-70-3	Dibenz(a,h)anthracene	64	---
TOTBFA	Total Benzofluoranthenes	64	---

Reported in µg/kg (ppb)

Semivolatile Surrogate Recovery

d14-p-Terphenyl	82.4%
2-Fluorobiphenyl	69.2%

ORGANICS ANALYSIS DATA SHEET

PNAs by SW8270D GC/MS

Page 1 of 1

**Sample ID: SPL-13-20130905
MS/MSD**

Lab Sample ID: XD62C
LIMS ID: 13-18529
Matrix: Soil
Data Release Authorized: *[Signature]*
Reported: 09/06/13

QC Report No: XD62-Landau Associates, Inc.
Project: Kaiser IA
118033.100.104
Date Sampled: 09/05/13
Date Received: 09/05/13

Date Extracted MS/MSD: 09/05/13
Date Analyzed MS: 09/06/13 15:06
MSD: 09/06/13 15:40
Instrument/Analyst MS: NT6/JZ
MSD: NT6/JZ
GPC Cleanup: No
Silica Gel Cleanup: No

Sample Amount MS: 7.77 g-dry-wt
MSD: 7.78 g-dry-wt
Final Extract Volume MS: 0.5 mL
MSD: 0.5 mL
Dilution Factor MS: 1.00
MSD: 1.00
Alumina Cleanup: No

Analyte	Sample	MS	Spike Added-MS	MS Recovery	MSD	Spike Added-MSD	MSD Recovery	RPD
Benzo(a)anthracene	< 64	921	1610	57.2%	1100	1610	68.3%	17.7%
Chrysene	< 64	1280	1610	79.5%	1310	1610	81.4%	2.3%
Benzo(a)pyrene	< 64	395	1610	24.5%	692	1610	43.0%	54.6%
Indeno(1,2,3-cd)pyrene	< 64	1200	1610	74.5%	1290	1610	80.1%	7.2%
Dibenz(a,h)anthracene	< 64	1180	1610	73.3%	1300	1610	80.7%	9.7%
Total Benzofluoranthenes	< 64	2530	3220	78.6%	2590	3210	80.7%	2.3%

Results reported in µg/kg
RPD calculated using sample concentrations per SW846.

ORGANICS ANALYSIS DATA SHEET

PNAs by SW8270D GC/MS

Page 1 of 1



Sample ID: MB-090513

METHOD BLANK

Lab Sample ID: MB-090513

LIMS ID: 13-18529

Matrix: Soil

Data Release Authorized:

Reported: 09/06/13

QC Report No: XD62-Landau Associates, Inc.

Project: Kaiser IA

118033.100.104

Date Sampled: NA

Date Received: NA

Date Extracted: 09/05/13

Date Analyzed: 09/06/13 11:41

Instrument/Analyst: NT6/JZ

GPC Cleanup: No

Alumina: No

Silica Gel: No

Sample Amount: 7.50 g-dry-wt

Final Extract Volume: 0.5 mL

Dilution Factor: 1.00

Percent Moisture: NA

CAS Number	Analyte	RL	Result
56-55-3	Benzo(a)anthracene	67	< 67 U
218-01-9	Chrysene	67	< 67 U
50-32-8	Benzo(a)pyrene	67	< 67 U
193-39-5	Indeno(1,2,3-cd)pyrene	67	< 67 U
53-70-3	Dibenz(a,h)anthracene	67	< 67 U
TOTBFA	Total Benzofluoranthenes	67	< 67 U

Reported in µg/kg (ppb)

Semivolatile Surrogate Recovery

d14-p-Terphenyl	92.0%
2-Fluorobiphenyl	74.0%

ORGANICS ANALYSIS DATA SHEET

PNAs by SW8270D GC/MS

Page 1 of 1

Sample ID: LCS-090513

LCS/LCSD

Lab Sample ID: LCS-090513

LIMS ID: 13-18529

Matrix: Soil

Data Release Authorized: *B*

Reported: 09/06/13

QC Report No: XD62-Landau Associates, Inc.

Project: Kaiser IA

118033.100.104

Date Sampled: NA

Date Received: 09/05/13

Date Extracted LCS/LCSD: 09/05/13

Sample Amount LCS: 7.50 g-dry-wt

LCSD: 7.50 g-dry-wt

Date Analyzed LCS: 09/06/13 12:15

Final Extract Volume LCS: 0.50 mL

LCSD: 09/06/13 12:50

LCSD: 0.50 mL

Instrument/Analyst LCS: NT6/JZ

Dilution Factor LCS: 1.00

LCSD: NT6/JZ

LCSD: 1.00

GPC Cleanup: No

Alumina Cleanup: No

Silica Gel Cleanup: No

Analyte	Spike		LCS		Spike		LCSD	
	LCS	Added-LCS	Recovery	LCS	Added-LCSD	Recovery	RPD	
Benzo(a)anthracene	1350	1670	80.8%	1350	1670	80.8%	0.0%	
Chrysene	1440	1670	86.2%	1440	1670	86.2%	0.0%	
Benzo(a)pyrene	1350	1670	80.8%	1400	1670	83.8%	3.6%	
Indeno(1,2,3-cd)pyrene	1440	1670	86.2%	1510	1670	90.4%	4.7%	
Dibenz(a,h)anthracene	1460	1670	87.4%	1590	1670	95.2%	8.5%	
Total Benzofluoranthenes	3000	3330	90.1%	3160	3330	94.9%	5.2%	

Semivolatile Surrogate Recovery

	LCS	LCSD
d14-p-Terphenyl	91.2%	89.6%
2-Fluorobiphenyl	72.4%	70.8%

Results reported in µg/kg

RPD calculated using sample concentrations per SW846.

SW8270 PNA SURROGATE RECOVERY SUMMARY

Matrix: Soil

QC Report No: XD62-Landau Associates, Inc.
Project: Kaiser IA
118033.100.104

<u>Client ID</u>	<u>TER</u>	<u>FBP</u>	<u>TOT OUT</u>
SPL-9-20130905	84.0%	69.6%	0
SPL-10-20130905	79.2%	64.8%	0
MB-090513	92.0%	74.0%	0
LCS-090513	91.2%	72.4%	0
LCSD-090513	89.6%	70.8%	0
SPL-13-20130905	89.6%	74.4%	0
SPL-13-20130905 MS	82.8%	70.0%	0
SPL-13-20130905 MSD	82.4%	69.2%	0
SPL-14-20130905	79.2%	67.2%	0

	LCS/MB LIMITS	QC LIMITS
(TER) = d14-p-Terphenyl	(30-160)	(30-160)
(FBP) = 2-Fluorobiphenyl	(30-160)	(30-160)

Prep Method: SW3546
Log Number Range: 13-18527 to 13-18530



Analytical Resources, Incorporated
Analytical Chemists and Consultants

September 13, 2013

Jessica Stone
Landau Associates, Inc.
950 Pacific Ave # 515
Tacoma, WA 98402

RE: Project: Kaiser IA
ARI Job No: XE56

Dear Jessica:

Please find enclosed the original Chain-of-Custody (COC) record, sample receipt documentation, and the analytical results for the samples from the projects referenced above. Analytical Resources, Inc. (ARI) accepted two soil samples on September 10, 2013 in good condition. For further details regarding sample receipt, please refer to the enclosed Cooler Receipt Form.

The samples were analyzed for cPAHs, as requested on the COC.

No analytical complications were noted.

An electronic copy of this report and all associated raw data will remain on file with ARI. If you have any questions or require additional information, please feel free to contact me at your convenience.

Sincerely,
ANALYTICAL RESOURCES, INC.

A handwritten signature in black ink, appearing to read "Kelly Bottem".

Kelly Bottem
Client Services Manager
206/695-6211
kellyb@arilabs.com

Enclosures

1 of 10

Seattle/Edmonds (425) 778-0907
 Tacoma (253) 926-2493
 Spokane (509) 327-9737
 Portland (503) 542-1080

LA LANDAU ASSOCIATES

XESS

Date 9/10/13
Page 1 of 1

Chain-of-Custody Record

Project Name Keiser IA Project No. 118033 100.104

Project Location/Event Kaiser site Port of Tacoma
 Sampler's Name DAR

Project Contact DAVE FISCHER
JESS STONE SICIM MATH
 Send Results To ANNAL HELMSTADT, BILL EVANS, DAVE FISCHER

Testing Parameters

Turnaround Time
 Standard
 Accelerated
 1-2 day TAT
Standard
9/10/13

Sample I.D.	Date	Time	Matrix	No. of Containers	Observations/Comments
<u>SPL-15-20130910</u>	<u>9/10/13</u>	<u>9:23</u>	<u>Soil</u>	<u>1</u>	<u>X</u> Allow water samples to settle, collect aliquot from clear portion
<u>SPL-16-20130910</u>	<u>9/10/13</u>	<u>9:37</u>	<u>Soil</u>	<u>1</u>	<u>X</u> NWTPH-Dx - run acid wash/silica gel cleanup

Special Shipment/Handling or Storage Requirements Ice

Relinquished by: David Rypert
 Signature David Rypert
 Printed Name Landau Associates
 Company Landau Associates

Received by: Rich Vukobrat
 Signature Rich Vukobrat
 Printed Name ARI
 Company ARI
 Date 9/10/13 Time 12:15

Relinquished by: _____
 Signature _____
 Printed Name _____
 Company _____
 Date _____ Time _____

Received by: _____
 Signature _____
 Printed Name _____
 Company _____
 Date _____ Time _____

Method of Shipment Courier

WHITE COPY - Project File

YELLOW COPY - Laboratory

PINK COPY - Client Representative

Rev 8/09



Cooler Receipt Form

ARI Client Landau

Project Name: Kaiser IA

COC No(s) _____ (NA)

Delivered by Fed-Ex UPS Courier Hand Delivered Other: _____

Assigned ARI Job No XE56

Tracking No: _____ (NA)

Preliminary Examination Phase:

Were intact, properly signed and dated custody seals attached to the outside of to cooler? YES NO

Were custody papers included with the cooler? YES NO

Were custody papers properly filled out (ink, signed, etc) YES NO

Temperature of Cooler(s) (°C) (recommended 2.0-6.0 °C for chemistry)..... 6.9

If cooler temperature is out of compliance fill out form 00070F

Cooler Accepted by: [Signature] Date: 9/10/13 Time: 1:15 Temp Gun ID# 1224/12224

Complete custody forms and attach all shipping documents

Log-In Phase:

Was a temperature blank included in the cooler? YES NO

What kind of packing material was used? ... Bubble Wrap Wet Ice Gel Packs Baggies Foam Block Paper Other: _____

Was sufficient ice used (if appropriate)? NA YES NO

Were all bottles sealed in individual plastic bags? YES NO

Did all bottles arrive in good condition (unbroken)? YES NO

Were all bottle labels complete and legible? YES NO

Did the number of containers listed on COC match with the number of containers received? YES NO

Did all bottle labels and tags agree with custody papers? YES NO

Were all bottles used correct for the requested analyses? YES NO

Do any of the analyses (bottles) require preservation? (attach preservation sheet, excluding VOCs) (NA) YES NO

Were all VOC vials free of air bubbles? (NA) YES NO

Was sufficient amount of sample sent in each bottle? YES NO

Date VOC Trip Blank was made at ARI..... (NA)

Was Sample Split by ARI: (NA) YES Date/Time: _____ Equipment: _____ Split by: _____

Samples Logged by: AV Date: 9/10/13 Time: 1430

**** Notify Project Manager of discrepancies or concerns ****

Sample ID on Bottle	Sample ID on COC	Sample ID on Bottle	Sample ID on COC

Additional Notes, Discrepancies, & Resolutions:

By: _____ Date: _____

			Small → "sm"
			Peabubbles → "pb"
			Large → "lg"
			Headspace → "hs"



Cooler Temperature Compliance Form

XES6

Cooler#:	Temperature(°C):	
Sample ID	Bottle Count	Bottle Type
Samples received above 6°C		

Cooler#:	Temperature(°C):	
Sample ID	Bottle Count	Bottle Type

Cooler#:	Temperature(°C):	
Sample ID	Bottle Count	Bottle Type

Cooler#:	Temperature(°C):	
Sample ID	Bottle Count	Bottle Type

Completed by: AV Date: 9/10/13 Time: 14:30

Sample ID Cross Reference Report



ARI Job No: XE56
Client: Landau Associates, Inc.
Project Event: 118033.100.104
Project Name: Kaiser IA

Sample ID	ARI Lab ID	ARI LIMS ID	Matrix	Sample Date/Time	VTSR
1. SPL-15-20130910	XE56A	13-19038	Soil	09/10/13 09:23	09/10/13 12:15
2. SPL-16-20130910	XE56B	13-19039	Soil	09/10/13 09:37	09/10/13 12:15

ORGANICS ANALYSIS DATA SHEET

PNA's by SW8270D GC/MS

Page 1 of 1



Sample ID: SPL-15-20130910

SAMPLE

Lab Sample ID: XE56A
LIMS ID: 13-19038
Matrix: Soil
Data Release Authorized: *[Signature]*
Reported: 09/13/13

QC Report No: XE56-Landau Associates, Inc.
Project: Kaiser IA
118033.100.104
Date Sampled: 09/10/13
Date Received: 09/10/13

Date Extracted: 09/10/13
Date Analyzed: 09/12/13 20:43
Instrument/Analyst: NT4/JZ
GPC Cleanup: No
Alumina: No
Silica Gel: No

Sample Amount: 9.92 g-dry-wt
Final Extract Volume: 0.5 mL
Dilution Factor: 1.00
Percent Moisture: 5.8%

CAS Number	Analyte	RL	Result
56-55-3	Benzo(a)anthracene	50	< 50 U
218-01-9	Chrysene	50	< 50 U
50-32-8	Benzo(a)pyrene	50	< 50 U
193-39-5	Indeno(1,2,3-cd)pyrene	50	< 50 U
53-70-3	Dibenz(a,h)anthracene	50	< 50 U
TOTBFA	Total Benzofluoranthenes	50	< 50 U

Reported in µg/kg (ppb)

Semivolatile Surrogate Recovery

d14-p-Terphenyl	84.8%
2-Fluorobiphenyl	70.0%

ORGANICS ANALYSIS DATA SHEET

PNA's by SW8270D GC/MS

Page 1 of 1

Sample ID: SPL-16-20130910

SAMPLE

Lab Sample ID: XE56B
LIMS ID: 13-19039
Matrix: Soil
Data Release Authorized: *AB*
Reported: 09/13/13

QC Report No: XE56-Landau Associates, Inc.
Project: Kaiser IA
118033.100.104
Date Sampled: 09/10/13
Date Received: 09/10/13

Date Extracted: 09/10/13
Date Analyzed: 09/12/13 21:13
Instrument/Analyst: NT4/JZ
GPC Cleanup: No
Alumina: No
Silica Gel: No

Sample Amount: 9.65 g-dry-wt
Final Extract Volume: 0.5 mL
Dilution Factor: 1.00
Percent Moisture: 8.4%

CAS Number	Analyte	RL	Result
56-55-3	Benzo(a)anthracene	52	< 52 U
218-01-9	Chrysene	52	< 52 U
50-32-8	Benzo(a)pyrene	52	< 52 U
193-39-5	Indeno(1,2,3-cd)pyrene	52	< 52 U
53-70-3	Dibenz(a,h)anthracene	52	< 52 U
TOTBFA	Total Benzofluoranthenes	52	< 52 U

Reported in µg/kg (ppb)

Semivolatile Surrogate Recovery

d14-p-Terphenyl	88.8%
2-Fluorobiphenyl	70.8%

ORGANICS ANALYSIS DATA SHEET

PNAs by SW8270D GC/MS

Page 1 of 1

Sample ID: MB-091013

METHOD BLANK

Lab Sample ID: MB-091013

LIMS ID: 13-19038

Matrix: Soil

Data Release Authorized: 

Reported: 09/13/13

QC Report No: XE56-Landau Associates, Inc.

Project: Kaiser IA

118033.100.104

Date Sampled: NA

Date Received: NA

Date Extracted: 09/10/13

Date Analyzed: 09/12/13 18:42

Instrument/Analyst: NT4/JZ

GPC Cleanup: No

Alumina: No

Silica Gel: No

Sample Amount: 7.50 g-dry-wt

Final Extract Volume: 0.5 mL

Dilution Factor: 1.00

Percent Moisture: NA

CAS Number	Analyte	RL	Result
56-55-3	Benzo(a)anthracene	67	< 67 U
218-01-9	Chrysene	67	< 67 U
50-32-8	Benzo(a)pyrene	67	< 67 U
193-39-5	Indeno(1,2,3-cd)pyrene	67	< 67 U
53-70-3	Dibenz(a,h)anthracene	67	< 67 U
TOTBFA	Total Benzofluoranthenes	67	< 67 U

Reported in µg/kg (ppb)

Semivolatile Surrogate Recovery

d14-p-Terphenyl	89.6%
2-Fluorobiphenyl	72.4%

SW8270 PNA SURROGATE RECOVERY SUMMARY



Matrix: Soil

QC Report No: XE56-Landau Associates, Inc.
Project: Kaiser IA
118033.100.104

<u>Client ID</u>	<u>TER</u>	<u>FBP</u>	<u>TOT OUT</u>
MB-091013	89.6%	72.4%	0
LCS-091013	88.8%	74.0%	0
LCSD-091013	90.8%	69.2%	0
SPL-15-20130910	84.8%	70.0%	0
SPL-16-20130910	88.8%	70.8%	0

	<u>LCS/MB LIMITS</u>	<u>QC LIMITS</u>
(TER) = d14-p-Terphenyl	(30-160)	(30-160)
(FBP) = 2-Fluorobiphenyl	(30-160)	(30-160)

Prep Method: SW3546
Log Number Range: 13-19038 to 13-19039

ORGANICS ANALYSIS DATA SHEET

PNAs by SW8270D GC/MS

Page 1 of 1

Sample ID: LCS-091013

LCS/LCSD

Lab Sample ID: LCS-091013

LIMS ID: 13-19038

Matrix: Soil

Data Release Authorized: *AS*

Reported: 09/13/13

QC Report No: XE56-Landau Associates, Inc.

Project: Kaiser IA

118033.100.104

Date Sampled: NA

Date Received: 09/10/13

Date Extracted LCS/LCSD: 09/10/13

Sample Amount LCS: 7.50 g-dry-wt

LCSD: 7.50 g-dry-wt

Date Analyzed LCS: 09/12/13 19:13

Final Extract Volume LCS: 0.50 mL

LCSD: 09/12/13 19:43

LCSD: 0.50 mL

Instrument/Analyst LCS: NT4/JZ

Dilution Factor LCS: 1.00

LCSD: NT4/JZ

LCSD: 1.00

GPC Cleanup: No

Alumina Cleanup: No

Silica Gel Cleanup: No

Analyte	Spike		LCS		Spike		LCSD	
	LCS	Added-LCS	Recovery	LCSD	Added-LCSD	Recovery	RPD	
Benzo(a)anthracene	1230	1670	73.7%	1250	1670	74.9%	1.6%	
Chrysene	1230	1670	73.7%	1280	1670	76.6%	4.0%	
Benzo(a)pyrene	1110	1670	66.5%	1040	1670	62.3%	6.5%	
Indeno(1,2,3-cd)pyrene	1220	1670	73.1%	1240	1670	74.3%	1.6%	
Dibenz(a,h)anthracene	1100	1670	65.9%	1280	1670	76.6%	15.1%	
Total Benzofluoranthenes	2690	3330	80.8%	2640	3330	79.3%	1.9%	

Semivolatile Surrogate Recovery

	LCS	LCSD
d14-p-Terphenyl	88.8%	90.8%
2-Fluorobiphenyl	74.0%	69.2%

Results reported in µg/kg

RPD calculated using sample concentrations per SW846.



Analytical Resources, Incorporated
Analytical Chemists and Consultants

September 16, 2013

Jessica Stone
Landau Associates, Inc.
950 Pacific Ave # 515
Tacoma, WA 98402

RE: Project: Kaiser IA
ARI Job No: XE88

Dear Jessica:

Please find enclosed the original Chain-of-Custody (COC) record, sample receipt documentation, and the analytical results for the samples from the projects referenced above. Analytical Resources, Inc. (ARI) accepted two soil samples on September 12, 2013 in good condition. For further details regarding sample receipt, please refer to the enclosed Cooler Receipt Form.

The samples were analyzed for cPAHs, as requested on the COC.

No analytical complications were noted.

An electronic copy of this report and all associated raw data will remain on file with ARI. If you have any questions or require additional information, please feel free to contact me at your convenience.

Sincerely,
ANALYTICAL RESOURCES, INC.

A handwritten signature in black ink, appearing to read "Kelly Bottem".

Kelly Bottem
Client Services Manager
206/695-6211
kellyb@arilabs.com

Enclosures



Chain-of-Custody Record

Project Name Kaiser IA Project No. 118053.100.104
 Project Location/Event Port of Tacoma WA
 Sampler's Name DAR
 Project Contact DAVE FISCHER
 Send Results To Jess Stone, Anne Halvorsen, Bill Evans, Dave Fischer, Matt

Sample I.D.	Date	Time	Matrix	No. of Containers	Testing Parameters	Observations/Comments
<u>SPL-17-20130912</u>	<u>9/12/13</u>	<u>11:43</u>	<u>Soil</u>	<u>1</u>		<u>X</u> Allow water samples to settle, collect aliquot from clear portion
<u>SPL-18-20130912</u>	<u>9/12/13</u>	<u>11:29</u>	<u>Soil</u>	<u>1</u>		<u>X</u> NWTPH-Dx - run acid wash/silica gel cleanup
						<u>run samples standardized to</u> _____ product _____
						<u>Analyze for EPH if no specific product identified</u>
						VOC/BTEX/VPH (soil): <u>non-preserved</u> <u>preserved w/methanol</u> <u>preserved w/sodium bisulfate</u> <u>Freeze upon receipt</u>
						<u>Dissolved metal water samples field filtered</u>
						Other _____

Turnaround Time
 Standard
 Accelerated
 1-2 Day TAT

Special Shipment/Handling or Storage Requirements Ice Method of Shipment Carrier

Relinquished by	Received by	Relinquished by	Received by
Signature _____ Printed Name <u>David Rupert</u> Company <u>Lander Associates</u> Date <u>9/12/13</u> Time <u>12:15</u>	Signature _____ Printed Name <u>Rich Williams</u> Company <u>ARI</u> Date <u>9/12/13</u> Time <u>12:15</u>	Signature _____ Printed Name _____ Company _____ Date _____ Time _____	Signature _____ Printed Name _____ Company _____ Date _____ Time _____



Cooler Receipt Form

ARI Client: Lanlan

Project Name: Kaiser IA

COC No(s): _____ NA

Delivered by: Fed-Ex UPS Courier Hand Delivered Other: _____

Assigned ARI Job No. XE88

Tracking No: _____ NA

Preliminary Examination Phase:

Were intact, properly signed and dated custody seals attached to the outside of to cooler? YES NO
 Were custody papers included with the cooler? YES NO
 Were custody papers properly filled out (ink, signed, etc.) YES NO
 Temperature of Cooler(s) (°C) (recommended 2.0-6.0 °C for chemistry).....

If cooler temperature is out of compliance fill out form 00070F
 Temp Gun ID#: 122412224

Cooler Accepted by: _____ Date: 9/12/13 Time: 1215

Complete custody forms and attach all shipping documents

Log-In Phase:

Was a temperature blank included in the cooler? YES NO
 What kind of packing material was used? ... Bubble Wrap Wet Ice Gel Packs Baggies Foam Block Paper Other: _____
 Was sufficient ice used (if appropriate)? .. NA YES NO
 Were all bottles sealed in individual plastic bags? YES NO
 Did all bottles arrive in good condition (unbroken)? YES NO
 Were all bottle labels complete and legible? YES NO
 Did the number of containers listed on COC match with the number of containers received? YES NO
 Did all bottle labels and tags agree with custody papers? YES NO
 Were all bottles used correct for the requested analyses? YES NO
 Do any of the analyses (bottles) require preservation? (attach preservation sheet, excluding VOCs)... NA YES NO
 Were all VOC vials free of air bubbles? NA YES NO
 Was sufficient amount of sample sent in each bottle? YES NO
 Date VOC Trip Blank was made at ARI..... NA
 Was Sample Split by ARI: NA YES Date/Time: _____ Equipment: _____ Split by: _____

Samples Logged by: JM Date: 9/12/13 Time: 1424

**** Notify Project Manager of discrepancies or concerns ****

Sample ID on Bottle	Sample ID on COC	Sample ID on Bottle	Sample ID on COC

Additional Notes, Discrepancies, & Resolutions:

By: _____ Date: _____

<p>Small Air Bubbles - 2mm</p>	<p>Peabubbles 2-4 mm</p>	<p>LARGE Air Bubbles > 4 mm</p>	<p>Small → "sm" (< 2 mm)</p> <p>Peabubbles → "pb" (2 to <4 mm)</p> <p>Large → "lg" (4 to <6 mm)</p> <p>Headspace → "hs" (>6 mm)</p>
------------------------------------	------------------------------	--	---

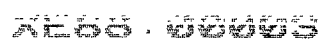

Sample ID Cross Reference Report



ARI Job No: XE88
Client: Landau Associates, Inc.
Project Event: 118053.100.104
Project Name: Kaiser IA

Sample ID	ARI Lab ID	ARI LIMS ID	Matrix	Sample Date/Time	VTSR
1. SPL-17-20130912	XE88A	13-19226	Soil	09/12/13 11:43	09/12/13 12:15
2. SPL-18-20130912	XE88B	13-19227	Soil	09/12/13 11:29	09/12/13 12:15

ORGANICS ANALYSIS DATA SHEET

PNAs by SW8270D GC/MS

Page 1 of 1

Sample ID: SPL-17-20130912

SAMPLE

Lab Sample ID: XE88A
LIMS ID: 13-19226
Matrix: Soil
Data Release Authorized: 
Reported: 09/16/13

QC Report No: XE88-Landau Associates, Inc.
Project: Kaiser IA
118053.100.104
Date Sampled: 09/12/13
Date Received: 09/12/13

Date Extracted: 09/13/13
Date Analyzed: 09/13/13 16:41
Instrument/Analyst: NT4/JZ
GPC Cleanup: No
Alumina: No
Silica Gel: No

Sample Amount: 8.37 g-dry-wt
Final Extract Volume: 0.5 mL
Dilution Factor: 1.00
Percent Moisture: 7.3%

CAS Number	Analyte	RL	Result
56-55-3	Benzo(a)anthracene	60	< 60 U
218-01-9	Chrysene	60	< 60 U
50-32-8	Benzo(a)pyrene	60	< 60 U
193-39-5	Indeno(1,2,3-cd)pyrene	60	< 60 U
53-70-3	Dibenz(a,h)anthracene	60	< 60 U
TOTBFA	Total Benzofluoranthenes	60	< 60 U

Reported in µg/kg (ppb)

Semivolatile Surrogate Recovery

d14-p-Terphenyl	87.2%
2-Fluorobiphenyl	70.0%

ORGANICS ANALYSIS DATA SHEET

PNAs by SW8270D GC/MS

Page 1 of 1

Sample ID: SPL-18-20130912

SAMPLE

Lab Sample ID: XE88B

LIMS ID: 13-19227

Matrix: Soil

Data Release Authorized: 

Reported: 09/16/13

QC Report No: XE88-Landau Associates, Inc.

Project: Kaiser IA

118053.100.104

Date Sampled: 09/12/13

Date Received: 09/12/13

Date Extracted: 09/13/13

Date Analyzed: 09/13/13 17:11

Instrument/Analyst: NT4/JZ

GPC Cleanup: No

Alumina: No

Silica Gel: No

Sample Amount: 8.33 g-dry-wt

Final Extract Volume: 0.5 mL

Dilution Factor: 1.00

Percent Moisture: 7.8%

CAS Number	Analyte	RL	Result
56-55-3	Benzo (a) anthracene	60	88
218-01-9	Chrysene	60	180
50-32-8	Benzo (a) pyrene	60	< 60 U
193-39-5	Indeno (1,2,3-cd) pyrene	60	< 60 U
53-70-3	Dibenz (a,h) anthracene	60	< 60 U
TOTBFA	Total Benzofluoranthenes	60	120

Reported in µg/kg (ppb)

Semivolatile Surrogate Recovery

d14-p-Terphenyl	81.2%
2-Fluorobiphenyl	67.6%

ORGANICS ANALYSIS DATA SHEET

PNAs by SW8270D GC/MS

Page 1 of 1

Sample ID: MB-091313

METHOD BLANK

Lab Sample ID: MB-091313

LIMS ID: 13-19226

Matrix: Soil

Data Release Authorized: *AS*

Reported: 09/16/13

QC Report No: XE88-Landau Associates, Inc.

Project: Kaiser IA

118053.100.104

Date Sampled: NA

Date Received: NA

Date Extracted: 09/13/13

Date Analyzed: 09/13/13 15:11

Instrument/Analyst: NT4/JZ

GPC Cleanup: No

Alumina: No

Silica Gel: No

Sample Amount: 7.50 g-dry-wt

Final Extract Volume: 0.5 mL

Dilution Factor: 1.00

Percent Moisture: NA

CAS Number	Analyte	RL	Result
56-55-3	Benzo(a)anthracene	67	< 67 U
218-01-9	Chrysene	67	< 67 U
50-32-8	Benzo(a)pyrene	67	< 67 U
193-39-5	Indeno(1,2,3-cd)pyrene	67	< 67 U
53-70-3	Dibenz(a,h)anthracene	67	< 67 U
TOTBFA	Total Benzofluoranthenes	67	< 67 U

Reported in µg/kg (ppb)

Semivolatile Surrogate Recovery

d14-p-Terphenyl	86.0%
2-Fluorobiphenyl	70.8%

SW8270 PNA SURROGATE RECOVERY SUMMARY

Matrix: Soil

QC Report No: XE88-Landau Associates, Inc.
Project: Kaiser IA
118053.100.104

<u>Client ID</u>	<u>TER</u>	<u>FBP</u>	<u>TOT OUT</u>
MB-091313	86.0%	70.8%	0
LCS-091313	85.2%	68.4%	0
LCSD-091313	81.6%	64.4%	0
SPL-17-20130912	87.2%	70.0%	0
SPL-18-20130912	81.2%	67.6%	0

	<u>LCS/MB LIMITS</u>	<u>QC LIMITS</u>
(TER) = d14-p-Terphenyl	(30-160)	(30-160)
(FBP) = 2-Fluorobiphenyl	(30-160)	(30-160)

Prep Method: SW3546
Log Number Range: 13-19226 to 13-19227

ORGANICS ANALYSIS DATA SHEET

PNAs by SW8270D GC/MS

Page 1 of 1

Sample ID: LCS-091313

LCS/LCSD

Lab Sample ID: LCS-091313

LIMS ID: 13-19226

Matrix: Soil

Data Release Authorized: *AS*

Reported: 09/16/13

QC Report No: XE88-Landau Associates, Inc.

Project: Kaiser IA

118053.100.104

Date Sampled: NA

Date Received: 09/12/13

Date Extracted LCS/LCSD: 09/13/13

Sample Amount LCS: 7.50 g-dry-wt

LCSD: 7.50 g-dry-wt

Date Analyzed LCS: 09/13/13 15:41

Final Extract Volume LCS: 0.50 mL

LCSD: 09/13/13 16:11

LCSD: 0.50 mL

Instrument/Analyst LCS: NT4/JZ

Dilution Factor LCS: 1.00

LCSD: NT4/JZ

LCSD: 1.00

GPC Cleanup: No

Alumina Cleanup: No

Silica Gel Cleanup: No

Analyte	Spike		LCS		Spike		LCSD	
	LCS	Added-LCS	Recovery	LCS	Added-LCSD	Recovery	RPD	
Benzo(a)anthracene	1190	1670	71.3%	1130	1670	67.7%	5.2%	
Chrysene	1180	1670	70.7%	1170	1670	70.1%	0.9%	
Benzo(a)pyrene	1070	1670	64.1%	963	1670	57.7%	10.5%	
Indeno(1,2,3-cd)pyrene	1260	1670	75.4%	1270	1670	76.0%	0.8%	
Dibenz(a,h)anthracene	1290	1670	77.2%	1300	1670	77.8%	0.8%	
Total Benzofluoranthenes	2510	3330	75.4%	2440	3330	73.3%	2.8%	

Semivolatile Surrogate Recovery

	LCS	LCSD
d14-p-Terphenyl	85.2%	81.6%
2-Fluorobiphenyl	68.4%	64.4%

Results reported in µg/kg

RPD calculated using sample concentrations per SW846.



Analytical Resources, Incorporated
Analytical Chemists and Consultants

September 17, 2013

Jessica Stone
Landau Associates, Inc.
950 Pacific Ave # 515
Tacoma, WA 98402

RE: Project: Kaiser IA
ARI Job No: XF22

Dear Jessica:

Please find enclosed the original Chain-of-Custody (COC) record, sample receipt documentation, and the analytical results for the samples from the projects referenced above. Analytical Resources, Inc. (ARI) accepted two soil samples on September 13, 2013 in good condition. For further details regarding sample receipt, please refer to the enclosed Cooler Receipt Form.

The samples were analyzed for cPAHs, as requested on the COC.

No analytical complications were noted.

An electronic copy of this report and all associated raw data will remain on file with ARI. If you have any questions or require additional information, please feel free to contact me at your convenience.

Sincerely,
ANALYTICAL RESOURCES, INC.

A handwritten signature in black ink, appearing to read "Kelly Bottem".

Kelly Bottem
Client Services Manager
206/695-6211
kellyb@arilabs.com

Enclosures

- Seattle/Edmonds (425) 778-0907
- Tacoma (253) 926-2493
- Spokane (509) 327-9737
- Portland (503) 542-1080



Chain-of-Custody Record

XFL

Date 9/13/13
Page 1 of 1

Project Name Kaiser IA Project No. 118033.100.104

Project Location/Event Kaiser Port of Tacoma

Sampler's Name DAR / DAM / SMM

Project Contact DAVE FISCHER

Send Results To Jessica Stone, Sierra Mott, Bill Evans, Dave Fischer

Sample I.D.	Date	Time	Matrix	No. of Containers	Testing Parameters	Observations/Comments
<u>SPL-19-20130913</u>	<u>9/15/13</u>	<u>10:00</u>	<u>Soil</u>	<u>1</u>	<u>X</u>	<u>X</u> Allow water samples to settle, collect aliquot from clear portion
<u>SPL-20-20130913</u>	<u>9/13/13</u>	<u>9:50</u>	<u>Soil</u>	<u>1</u>	<u>X</u>	<u>X</u> NWTPH-Dx - run acid wash/silica gel cleanup
						<u>run samples standardized to _____ product</u>
						<u>Analyze for EPH if no specific product identified</u>
						<u>VOC/BTEX/VPH (soil):</u>
						<u>non-preserved</u>
						<u>preserved w/methanol</u>
						<u>preserved w/sodium bisulfate</u>
						<u>Freeze upon receipt</u>
						<u>Dissolved metal water samples field filtered</u>
						<u>Other _____</u>

Turnaround Time
 Standard
 Accelerated
 1-2 Day TAT

Special Shipment/Handling or Storage Requirements Ice Method of Shipment Courier

Relinquished by	Received by
Signature <u>Sierra Mott</u> Printed Name <u>Sierra Mott</u> Company <u>Landau Associates</u> Date <u>9/13/13</u> Time <u>1434</u>	Signature <u>Rich Hudson</u> Printed Name <u>Rich Hudson</u> Company <u>API</u> Date <u>9/13/13</u> Time <u>1435</u>

Received by
 Signature _____
 Printed Name _____
 Company _____
 Date _____ Time _____

Relinquished by
 Signature _____
 Printed Name _____
 Company _____
 Date _____ Time _____



Cooler Receipt Form

ARI Client: Landau

Project Name: Kaiser LA

COC No(s): _____ NA

Delivered by: Fed-Ex UPS Courier Hand Delivered Other: _____

Assigned ARI Job No: 1522

Tracking No: _____ NA

Preliminary Examination Phase:

Were intact, properly signed and dated custody seals attached to the outside of to cooler? YES NO
 Were custody papers included with the cooler? YES NO
 Were custody papers properly filled out (ink, signed, etc.) YES NO
 Temperature of Cooler(s) (°C) (recommended 2.0-6.0 °C for chemistry) _____

If cooler temperature is out of compliance fill out form 00070F

Temp Gun ID#: 90877952

Cooler Accepted by: _____ Date: 9/13/13 Time: 1435
Complete custody forms and attach all shipping documents

Log-In Phase:

Was a temperature blank included in the cooler? YES NO
 What kind of packing material was used? ... Bubble Wrap Wet Ice Gel Packs Baggies Foam Block Paper Other: _____
 Was sufficient ice used (if appropriate)? NA YES NO
 Were all bottles sealed in individual plastic bags? YES NO
 Did all bottles arrive in good condition (unbroken)? YES NO
 Were all bottle labels complete and legible? YES NO
 Did the number of containers listed on COC match with the number of containers received? YES NO
 Did all bottle labels and tags agree with custody papers? YES NO
 Were all bottles used correct for the requested analyses? YES NO
 Do any of the analyses (bottles) require preservation? (attach preservation sheet, excluding VOCs)... NA YES NO
 Were all VOC vials free of air bubbles? NA YES NO
 Was sufficient amount of sample sent in each bottle? YES NO
 Date VOC Trip Blank was made at ARI: _____ NA
 Was Sample Split by ARI: NA YES Date/Time: _____ Equipment: _____ Split by: _____
 Samples Logged by: TS Date: 9/13/13 Time: 1704

**** Notify Project Manager of discrepancies or concerns ****

Sample ID on Bottle	Sample ID on COC	Sample ID on Bottle	Sample ID on COC

Additional Notes, Discrepancies, & Resolutions:

By: _____ Date: _____

			Small → "sm" (< 2 mm)
			Peabubbles → "pb" (2 to < 4 mm)
			Large → "lg" (4 to < 6 mm)
			Headspace → "hs" (> 6 mm)

Sample ID Cross Reference Report



ARI Job No: XF22
Client: Landau Associates, Inc.
Project Event: 118033.100.104
Project Name: Kaiser IA

Sample ID	ARI Lab ID	ARI LIMS ID	Matrix	Sample Date/Time	VTSR
1. SPL-19-20130913	XF22A	13-19547	Soil	09/13/13 10:00	09/13/13 14:35
2. SPL-20-20130913	XF22B	13-19548	Soil	09/13/13 09:50	09/13/13 14:35

ORGANICS ANALYSIS DATA SHEET

PNAs by SW8270D GC/MS

Page 1 of 1

Sample ID: SPL-19-20130913

SAMPLE

Lab Sample ID: XF22A

LIMS ID: 13-19547

Matrix: Soil

Data Release Authorized: *AB*

Reported: 09/17/13

QC Report No: XF22-Landau Associates, Inc.

Project: Kaiser IA

118033.100.104

Date Sampled: 09/13/13

Date Received: 09/13/13

Date Extracted: 09/16/13

Date Analyzed: 09/16/13 19:34

Instrument/Analyst: NT6/JZ

GPC Cleanup: No

Alumina: No

Silica Gel: No

Sample Amount: 7.63 g-dry-wt

Final Extract Volume: 0.5 mL

Dilution Factor: 1.00

Percent Moisture: 15.5%

CAS Number	Analyte	RL	Result
56-55-3	Benzo(a)anthracene	66	< 66 U
218-01-9	Chrysene	66	< 66 U
50-32-8	Benzo(a)pyrene	66	< 66 U
193-39-5	Indeno(1,2,3-cd)pyrene	66	< 66 U
53-70-3	Dibenz(a,h)anthracene	66	< 66 U
TOTBFA	Total Benzofluoranthenes	66	< 66 U

Reported in µg/kg (ppb)

Semivolatile Surrogate Recovery

d14-p-Terphenyl	78.0%
2-Fluorobiphenyl	65.6%

ORGANICS ANALYSIS DATA SHEET

PNA's by SW8270D GC/MS

Page 1 of 1

Sample ID: SPL-20-20130913

SAMPLE

Lab Sample ID: XF22B

LIMS ID: 13-19548

Matrix: Soil

Data Release Authorized: 

Reported: 09/17/13

QC Report No: XF22-Landau Associates, Inc.

Project: Kaiser IA

118033.100.104

Date Sampled: 09/13/13

Date Received: 09/13/13

Date Extracted: 09/16/13

Date Analyzed: 09/16/13 20:08

Instrument/Analyst: NT6/JZ

GPC Cleanup: No

Alumina: No

Silica Gel: No

Sample Amount: 7.76 g-dry-wt

Final Extract Volume: 0.5 mL

Dilution Factor: 1.00

Percent Moisture: 14.0%

CAS Number	Analyte	RL	Result
56-55-3	Benzo(a)anthracene	64	< 64 U
218-01-9	Chrysene	64	< 64 U
50-32-8	Benzo(a)pyrene	64	< 64 U
193-39-5	Indeno(1,2,3-cd)pyrene	64	< 64 U
53-70-3	Dibenz(a,h)anthracene	64	< 64 U
TOTBEA	Total Benzofluoranthenes	64	< 64 U

Reported in µg/kg (ppb)

Semivolatile Surrogate Recovery

d14-p-Terphenyl	80.0%
2-Fluorobiphenyl	62.4%

ORGANICS ANALYSIS DATA SHEET

PNAs by SW8270D GC/MS

Page 1 of 1

Sample ID: MB-091613

METHOD BLANK

Lab Sample ID: MB-091613

LIMS ID: 13-19547

Matrix: Soil

Data Release Authorized: 

Reported: 09/17/13

QC Report No: XF22-Landau Associates, Inc.

Project: Kaiser IA

118033.100.104

Date Sampled: NA

Date Received: NA

Date Extracted: 09/16/13

Date Analyzed: 09/16/13 17:52

Instrument/Analyst: NT6/JZ

GPC Cleanup: No

Alumina: No

Silica Gel: No

Sample Amount: 7.50 g-dry-wt

Final Extract Volume: 0.5 mL

Dilution Factor: 1.00

Percent Moisture: NA

CAS Number	Analyte	RL	Result
56-55-3	Benzo(a)anthracene	67	< 67 U
218-01-9	Chrysene	67	< 67 U
50-32-8	Benzo(a)pyrene	67	< 67 U
193-39-5	Indeno(1,2,3-cd)pyrene	67	< 67 U
53-70-3	Dibenz(a,h)anthracene	67	< 67 U
TOTBFA	Total Benzofluoranthenes	67	< 67 U

Reported in µg/kg (ppb)

Semivolatile Surrogate Recovery

d14-p-Terphenyl	83.2%
2-Fluorobiphenyl	68.8%

SW8270 PNA SURROGATE RECOVERY SUMMARY



Matrix: Soil

QC Report No: XF22-Landau Associates, Inc.
 Project: Kaiser IA
 118033.100.104

Client ID	TER	FBP	TOT OUT
MB-091613	83.2%	68.8%	0
LCS-091613	80.0%	66.0%	0
LCSD-091613	78.4%	67.6%	0
SPL-19-20130913	78.0%	65.6%	0
SPL-20-20130913	80.0%	62.4%	0

	LCS/MB LIMITS	QC LIMITS
(TER) = d14-p-Terphenyl	(30-160)	(30-160)
(FBP) = 2-Fluorobiphenyl	(30-160)	(30-160)

Prep Method: SW3546
 Log Number Range: 13-19547 to 13-19548

ORGANICS ANALYSIS DATA SHEET

PNA's by SW8270D GC/MS

Page 1 of 1

Sample ID: LCS-091613

LCS/LCSD

Lab Sample ID: LCS-091613

LIMS ID: 13-19547

Matrix: Soil

Data Release Authorized: *AB*

Reported: 09/17/13

QC Report No: XF22-Landau Associates, Inc.

Project: Kaiser IA

118033.100.104

Date Sampled: NA

Date Received: 09/13/13

Date Extracted LCS/LCSD: 09/16/13

Sample Amount LCS: 7.50 g-dry-wt

LCSD: 7.50 g-dry-wt

Date Analyzed LCS: 09/16/13 18:26

Final Extract Volume LCS: 0.50 mL

LCSD: 09/16/13 19:00

LCSD: 0.50 mL

Instrument/Analyst LCS: NT6/JZ

Dilution Factor LCS: 1.00

LCSD: NT6/JZ

LCSD: 1.00

GPC Cleanup: No

Alumina Cleanup: No

Silica Gel Cleanup: No

Analyte	LCS	Spike Added-LCS	LCS Recovery	LCSD	Spike Added-LCSD	LCSD Recovery	RPD
Benzo(a)anthracene	1310	1670	78.4%	1290	1670	77.2%	1.5%
Chrysene	1300	1670	77.8%	1270	1670	76.0%	2.3%
Benzo(a)pyrene	1300	1670	77.8%	1300	1670	77.8%	0.0%
Indeno(1,2,3-cd)pyrene	1390	1670	83.2%	1370	1670	82.0%	1.4%
Dibenz(a,h)anthracene	1390	1670	83.2%	1380	1670	82.6%	0.7%
Total Benzofluoranthenes	2660	3330	79.9%	2660	3330	79.9%	0.0%

Semivolatile Surrogate Recovery

	LCS	LCSD
d14-p-Terphenyl	80.0%	78.4%
2-Fluorobiphenyl	66.0%	67.6%

Results reported in µg/kg

RPD calculated using sample concentrations per SW846.



Analytical Resources, Incorporated
Analytical Chemists and Consultants

September 19, 2013

Jessica Stone
Landau Associates, Inc.
950 Pacific Ave # 515
Tacoma, WA 98402

RE: Project: Kaiser IA
ARI Job No: XF45

Dear Jessica:

Please find enclosed the original Chain-of-Custody (COC) record, sample receipt documentation, and the analytical results for the samples from the projects referenced above. Analytical Resources, Inc. (ARI) accepted seven soil samples on September 17, 2013 in good condition. For further details regarding sample receipt, please refer to the enclosed Cooler Receipt Form.

The samples were analyzed for cPAHs and NWTPH-Dx, as requested on the COC.

No analytical complications were noted.

An electronic copy of this report and all associated raw data will remain on file with ARI. If you have any questions or require additional information, please feel free to contact me at your convenience.

Sincerely,
ANALYTICAL RESOURCES, INC.

A handwritten signature in black ink that reads "Kelly Bottem".

Kelly Bottem
Client Services Manager
206/695-6211
kellyb@arilabs.com



Enclosures

- Seattle/Edmonds (425) 778-0907
- Tacoma (253) 926-2493
- Spokane (509) 927-9737
- Portland (503) 542-1080

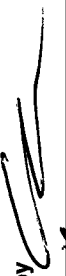

Chain-of-Custody Record

Date 9/17/13
 Page 1 of 1

Project Name <u>Keizer IA</u> Project No. <u>118033.100.104</u> Project Location/Event <u>Keizer Port of Tacoma</u> Sampler's Name <u>DAR I DAM</u> Project Contact <u>Dave Fischer</u> Send Results To <u>Anna Halvorsen, Bill Evans, Dave Fischer</u>	Turnaround Time <input type="checkbox"/> Standard <input type="checkbox"/> Accelerated <input checked="" type="checkbox"/> 1-2 day TAT	Observations/Comments <u>for R.M.L-1-20130917 and R.M.L-13-20130917 2 day TAT for BF-1-20130917</u> <u>and BF-2-20130917 and BF-3-20130917</u> <input checked="" type="checkbox"/> Allow water samples to settle, collect aliquot from clear portion <input checked="" type="checkbox"/> NWTPH-DX - run acid wash/silica gel cleanup				
Sample I.D. <u>R.M.L-1-20130917</u> <u>R.M.L-13-20130917</u> <u>BF-1-20130917</u> <u>BF-2-20130917</u> <u>BF-3-20130917</u>	Date <u>9/17/13</u> <u>↓</u> <u>↓</u> <u>↓</u>	Time <u>1244</u> <u>1227</u> <u>1340</u> <u>1250</u> <u>1306</u>	Matrix <u>SOIL</u> <u>↓</u> <u>↓</u> <u>↓</u>	No. of Containers <u>1</u> <u>↓</u> <u>↓</u> <u>↓</u>	Testing Parameters <u>CPH 8270 D</u> <u>NWTPH-DX</u>	run samples standardized to _____ product Analyze for EPH if no specific product identified VOC/BTEX/VPH (soil): <input type="checkbox"/> non-preserved <input type="checkbox"/> preserved w/methanol <input type="checkbox"/> preserved w/sodium bisulfate <input type="checkbox"/> Freeze upon receipt <input type="checkbox"/> Dissolved metal water samples field filtered Other _____ Method of Shipment <u>Courier</u>
Special Shipment/Handling or Storage Requirements <u>Ice</u>	Received by Signature  Printed Name <u>R. G. Heuser</u> Company _____ Date <u>9/17/13</u> Time <u>1955</u>	Relinquished by Signature  Printed Name <u>Dana Malkemus</u> Company <u>LA</u> Date <u>9/17/13</u> Time <u>1355</u>	Received by Signature _____ Printed Name _____ Company _____ Date _____ Time _____	Relinquished by Signature _____ Printed Name _____ Company _____ Date _____ Time _____		

Chain-of-Custody Record

Project Name Kaiser IA Project No. 118033.100.104

Project Location/Event Kaiser, Part of Tacoma

Sampler's Name DAIR / DAM

Project Contact David Fischer Sierra Mott

Send Results To Annal Halverson, Bill Evans, Dave Fischer

Testing Parameters

Turnaround Time
 Standard
 Accelerated
 1-2 Day TAT

Sample I.D. Date Time Matrix No. of Containers

SPL-21-20130917 9/17/13 11 35 Soil 1 X

SPL-22-20130917 9/17/13 11 25 Soil 1 X

(PAH 6270)

Observations/Comments

X Allow water samples to settle, collect aliquot from clear portion
X NWTPH-Dx - run acid wash/silica gel cleanup

___ run samples standardized to _____ product
 ___ Analyze for EPH if no specific product identified
 VOC/BTEX/VPH (soil):
 ___ non-preserved
 ___ preserved w/methanol
 ___ preserved w/sodium bisulfate
 ___ Freeze upon receipt
 ___ Dissolved metal water samples field filtered
 Other _____

Special Shipment/Handling or Storage Requirements Ice

Method of Shipment Courier

Relinquished by
 Signature [Signature]
 Printed Name MAKKENS
 Company CAI
 Date 9/17/13 Time 1355

Received by
 Signature [Signature]
 Printed Name R. S. Halverson
 Company AFI
 Date 9/17/13 Time 1755

Received by
 Signature _____
 Printed Name _____
 Company _____
 Date _____ Time _____

54 4 01 : 000000

Sample ID Cross Reference Report



ARI Job No: XF45
Client: Landau Associates, Inc.
Project Event: 118033.100.104
Project Name: Kaiser IA

Sample ID	ARI Lab ID	ARI LIMS ID	Matrix	Sample Date/Time	VTSR
1. RML-1-20130917	XF45A	13-19664	Soil	09/17/13 12:44	09/17/13 13:55
2. RML-13-20130917	XF45B	13-19665	Soil	09/17/13 12:27	09/17/13 13:55
3. BF-1-20130917	XF45C	13-19666	Soil	09/17/13 13:40	09/17/13 13:55
4. BF-2-20130917	XF45D	13-19667	Soil	09/17/13 12:50	09/17/13 13:55
5. BF-3-20130917	XF45E	13-19668	Soil	09/17/13 13:06	09/17/13 13:55
6. SPL-21-20130917	XF45F	13-19669	Soil	09/17/13 11:35	09/17/13 13:55
7. SPL-22-20130917	XF45G	13-19670	Soil	09/17/13 11:25	09/17/13 13:55



Cooler Receipt Form

ARI Client: Landa

Project Name: Haizer IA

COC No(s): _____ NA

Delivered by: Fed-Ex UPS Courier Hand Delivered Other: _____

Assigned ARI Job No: XF45

Tracking No. _____ NA

Preliminary Examination Phase:

Were intact, properly signed and dated custody seals attached to the outside of cooler? YES NO
 Were custody papers included with the cooler? YES NO
 Were custody papers properly filled out (ink, signed, etc.) YES NO
 Temperature of Cooler(s) (°C) (recommended 2.0-6.0 °C for chemistry)..... 4.1

If cooler temperature is out of compliance fill out form 00070F Temp Gun ID#: 122412229

Cooler Accepted by: _____ Date: 9/17/13 Time: 1355

Complete custody forms and attach all shipping documents

Log-In Phase:

Was a temperature blank included in the cooler? YES NO
 What kind of packing material was used? ... Bubble Wrap Wet Ice Gel Packs Baggies Foam Block Paper Other: _____
 Was sufficient ice used (if appropriate)? NA YES NO
 Were all bottles sealed in individual plastic bags? YES NO
 Did all bottles arrive in good condition (unbroken)? YES NO
 Were all bottle labels complete and legible? YES NO
 Did the number of containers listed on COC match with the number of containers received? YES NO
 Did all bottle labels and tags agree with custody papers? YES NO
 Were all bottles used correct for the requested analyses? YES NO
 Do any of the analyses (bottles) require preservation? (attach preservation sheet, excluding VOCs)... NA YES NO
 Were all VOC vials free of air bubbles? NA YES NO
 Was sufficient amount of sample sent in each bottle? YES NO
 Date VOC Trip Blank was made at ARI: _____ NA
 Was Sample Split by ARI: NA YES Date/Time: _____ Equipment: _____ Split by: _____

Samples Logged by: JIM Date: 9/17/13 Time: 1536

**** Notify Project Manager of discrepancies or concerns ****

Sample ID on Bottle	Sample ID on COC	Sample ID on Bottle	Sample ID on COC

Additional Notes, Discrepancies, & Resolutions:

By: _____ Date: _____

			Small → "sm" (< 2 mm)
			Peabubbles → "pb" (2 to <4 mm)
			Large → "lg" (4 to <6 mm)
			Headspace → "hs" (>6 mm)

**ORGANICS ANALYSIS DATA SHEET
TOTAL DIESEL RANGE HYDROCARBONS**

NWTPHD by GC/FID-Silica and Acid Cleaned
Extraction Method: SW3546
Page 1 of 1

QC Report No: XF45-Landau Associates, Inc.
Project: Kaiser IA
118033.100.104

Matrix: Soil
Data Release Authorized: 
Reported: 09/19/13

ARI ID	Sample ID	Extraction Date	Analysis Date	EFV DF	Range/Surrogate	RL	Result
MB-091813 13-19664	Method Blank HC ID: ---	09/18/13	09/18/13	1.00	Diesel Range	5.0	< 5.0 U
			FID9	1.0	Motor Oil Range o-Terphenyl	10	< 10 U 86.9%
XF45A 13-19664	RML-1-20130917 HC ID: ---	09/18/13	09/18/13	1.00	Diesel Range	7.9	< 7.9 U
			FID9	1.0	Motor Oil Range o-Terphenyl	16	< 16 U 64.7%
XF45B 13-19665	RML-13-20130917 HC ID: DIESEL	09/18/13	09/18/13	1.00	Diesel Range	7.9	34
			FID9	1.0	Motor Oil Range o-Terphenyl	16	< 16 U 70.4%
XF45C 13-19666	BF-1-20130917 HC ID: DRO/MOTOR OIL	09/18/13	09/18/13	1.00	Diesel Range	5.2	320 E
			FID9	1.0	Motor Oil Range o-Terphenyl	10	660 E 59.9%
XF45C DL 13-19666	BF-1-20130917 HC ID: DRO/MOTOR OIL	09/18/13	09/19/13	1.00	Diesel Range	52	340
			FID9	10	Motor Oil Range o-Terphenyl	100	680 61.3%
XF45D 13-19667	BF-2-20130917 HC ID: ---	09/18/13	09/18/13	1.00	Diesel Range	5.2	< 5.2 U
			FID9	1.0	Motor Oil Range o-Terphenyl	10	< 10 U 90.1%
XF45E 13-19668	BF-3-20130917 HC ID: ---	09/18/13	09/18/13	1.00	Diesel Range	5.3	< 5.3 U
			FID9	1.0	Motor Oil Range o-Terphenyl	11	< 11 U 90.2%

Reported in mg/kg (ppm)

EFV-Effective Final Volume in mL.
DL-Dilution of extract prior to analysis.
RL-Reporting limit.

Diesel range quantitation on total peaks in the range from C12 to C24.
Motor Oil range quantitation on total peaks in the range from C24 to C38.
HC ID: DRO/RRO indicate results of organics or additional hydrocarbons in ranges are not identifiable.

CLEANED TPHD SURROGATE RECOVERY SUMMARY

Matrix: Soil

QC Report No: XF45-Landau Associates, Inc.
Project: Kaiser IA
118033.100.104

<u>Client ID</u>	<u>OTER</u>	<u>TOT OUT</u>
MB-091813	86.9%	0
LCS-091813	86.7%	0
LCSD-091813	91.7%	0
RML-1-20130917	64.7%	0
RML-13-20130917	70.4%	0
BF-1-20130917	59.9%	0
BF-1-20130917 DL	61.3%	0
BF-2-20130917	90.1%	0
BF-3-20130917	90.2%	0

	LCS/MB LIMITS	QC LIMITS
(OTER) = o-Terphenyl	(50-150)	(50-150)

Prep Method: SW3546
Log Number Range: 13-19664 to 13-19668

ORGANICS ANALYSIS DATA SHEET

NWTPHD by GC/FID-Silica and Acid Cleaned

Page 1 of 1

Sample ID: LCS-091813

LCS/LCSD

Lab Sample ID: LCS-091813

LIMS ID: 13-19664

Matrix: Soil

Data Release Authorized: 

Reported: 09/19/13

QC Report No: XF45-Landau Associates, Inc.

Project: Kaiser IA

118033.100.104

Date Sampled: 09/17/13

Date Received: 09/17/13

Date Extracted LCS/LCSD: 09/18/13

Sample Amount LCS: 10.0 g

LCSD: 10.0 g

Date Analyzed LCS: 09/18/13 17:24

Final Extract Volume LCS: 1.0 mL

LCSD: 09/18/13 17:46

LCSD: 1.0 mL

Instrument/Analyst LCS: FID/JLW

Dilution Factor LCS: 1.0

LCSD: FID/JLW

LCSD: 1.0

Range	LCS	Spike Added-LCS	LCS Recovery	LCSD	Spike Added-LCSD	LCSD Recovery	RPD
Diesel	116	150	77.3%	124	150	82.7%	6.7%

TPHD Surrogate Recovery

	LCS	LCSD
o-Terphenyl	86.7%	91.7%

Results reported in mg/kg

RPD calculated using sample concentrations per SW846.

TOTAL DIESEL RANGE HYDROCARBONS-EXTRACTION REPORT

Matrix: Soil
Date Received: 09/17/13

ARI Job: XF45
Project: Kaiser IA
118033.100.104

ARI ID	Client ID	Client Amt	Final Vol	Basis	Prep Date
13-19664-091813MB1	Method Blank	10.0 g	1.00 mL	-	09/18/13
13-19664-091813LCS1	Lab Control	10.0 g	1.00 mL	-	09/18/13
13-19664-091813LCSD1	Lab Control Dup	10.0 g	1.00 mL	-	09/18/13
13-19664-XF45A	RML-1-20130917	6.31 g	1.00 mL	D	09/18/13
13-19665-XF45B	RML-13-20130917	6.31 g	1.00 mL	D	09/18/13
13-19666-XF45C	BF-1-20130917	9.54 g	1.00 mL	D	09/18/13
13-19667-XF45D	BF-2-20130917	9.63 g	1.00 mL	D	09/18/13
13-19668-XF45E	BF-3-20130917	9.47 g	1.00 mL	D	09/18/13

ORGANICS ANALYSIS DATA SHEET

PNA's by SW8270D GC/MS

Page 1 of 1

Sample ID: RML-1-20130917

SAMPLE

Lab Sample ID: XF45A

LIMS ID: 13-19664

Matrix: Soil

Data Release Authorized: *AS*

Reported: 09/19/13

QC Report No: XF45-Landau Associates, Inc.

Project: Kaiser IA

118033.100.104

Date Sampled: 09/17/13

Date Received: 09/17/13

Date Extracted: 09/18/13

Date Analyzed: 09/18/13 18:37

Instrument/Analyst: NT6/JZ

GPC Cleanup: No

Alumina: No

Silica Gel: No

Sample Amount: 7.55 g-dry-wt

Final Extract Volume: 0.5 mL

Dilution Factor: 1.00

Percent Moisture: 37.5%

CAS Number	Analyte	RL	Result
56-55-3	Benzo(a)anthracene	66	< 66 U
218-01-9	Chrysene	66	< 66 U
50-32-8	Benzo(a)pyrene	66	< 66 U
193-39-5	Indeno(1,2,3-cd)pyrene	66	< 66 U
53-70-3	Dibenz(a,h)anthracene	66	< 66 U
TOTBFA	Total Benzofluoranthenes	66	< 66 U

Reported in µg/kg (ppb)

Semivolatile Surrogate Recovery

d14-p-Terphenyl	69.6%
2-Fluorobiphenyl	70.0%

ORGANICS ANALYSIS DATA SHEET

PNAs by SW8270D GC/MS

Page 1 of 1

Sample ID: RML-13-20130917

SAMPLE

Lab Sample ID: XF45B

LIMS ID: 13-19665

Matrix: Soil

Data Release Authorized: *[Signature]*

Reported: 09/19/13

QC Report No: XF45-Landau Associates, Inc.

Project: Kaiser IA

118033.100.104

Date Sampled: 09/17/13

Date Received: 09/17/13

Date Extracted: 09/18/13

Date Analyzed: 09/18/13 19:11

Instrument/Analyst: NT6/JZ

GPC Cleanup: No

Alumina: No

Silica Gel: No

Sample Amount: 7.56 g-dry-wt

Final Extract Volume: 0.5 mL

Dilution Factor: 1.00

Percent Moisture: 37.3%

CAS Number	Analyte	RL	Result
56-55-3	Benzo(a)anthracene	66	< 66 U
218-01-9	Chrysene	66	< 66 U
50-32-8	Benzo(a)pyrene	66	< 66 U
193-39-5	Indeno(1,2,3-cd)pyrene	66	< 66 U
53-70-3	Dibenz(a,h)anthracene	66	< 66 U
TOTBFA	Total Benzofluoranthenes	66	< 66 U

Reported in µg/kg (ppb)

Semivolatile Surrogate Recovery

d14-p-Terphenyl	59.6%
2-Fluorobiphenyl	61.2%

ORGANICS ANALYSIS DATA SHEET

PNA's by SW8270D GC/MS

Page 1 of 1

Sample ID: BF-1-20130917

SAMPLE

Lab Sample ID: XF45C

LIMS ID: 13-19666

Matrix: Soil

Data Release Authorized: 

Reported: 09/19/13

QC Report No: XF45-Landau Associates, Inc.

Project: Kaiser IA

118033.100.104

Date Sampled: 09/17/13

Date Received: 09/17/13

Date Extracted: 09/18/13

Date Analyzed: 09/18/13 19:45

Instrument/Analyst: NT6/JZ

GPC Cleanup: No

Alumina: No

Silica Gel: No

Sample Amount: 7.57 g-dry-wt

Final Extract Volume: 0.5 mL

Dilution Factor: 1.00

Percent Moisture: 5.4%

CAS Number	Analyte	RL	Result
56-55-3	Benzo(a)anthracene	66	< 66 U
218-01-9	Chrysene	66	< 66 U
50-32-8	Benzo(a)pyrene	66	< 66 U
193-39-5	Indeno(1,2,3-cd)pyrene	66	< 66 U
53-70-3	Dibenz(a,h)anthracene	66	< 66 U
TOTBFA	Total Benzofluoranthenes	66	< 66 U

Reported in µg/kg (ppb)

Semivolatile Surrogate Recovery

d14-p-Terphenyl	62.0%
2-Fluorobiphenyl	76.4%

ORGANICS ANALYSIS DATA SHEET

PNAs by SW8270D GC/MS

Page 1 of 1

**Sample ID: BF-2-20130917
SAMPLE**

Lab Sample ID: XF45D

LIMS ID: 13-19667

Matrix: Soil

Data Release Authorized:

Reported: 09/19/13

QC Report No: XF45-Landau Associates, Inc.

Project: Kaiser IA

118033.100.104

Date Sampled: 09/17/13

Date Received: 09/17/13

Date Extracted: 09/18/13

Date Analyzed: 09/18/13 20:18

Instrument/Analyst: NT6/JZ

GPC Cleanup: No

Alumina: No

Silica Gel: No

Sample Amount: 7.69 g-dry-wt

Final Extract Volume: 0.5 mL

Dilution Factor: 1.00

Percent Moisture: 4.0%

CAS Number	Analyte	RL	Result
56-55-3	Benzo(a)anthracene	65	< 65 U
218-01-9	Chrysene	65	< 65 U
50-32-8	Benzo(a)pyrene	65	< 65 U
193-39-5	Indeno(1,2,3-cd)pyrene	65	< 65 U
53-70-3	Dibenz(a,h)anthracene	65	< 65 U
TOTBFA	Total Benzofluoranthenes	65	< 65 U

Reported in µg/kg (ppb)

Semivolatile Surrogate Recovery

d14-p-Terphenyl	69.6%
2-Fluorobiphenyl	64.8%

ORGANICS ANALYSIS DATA SHEET

PNA's by SW8270D GC/MS

Page 1 of 1



Sample ID: BF-3-20130917

SAMPLE

Lab Sample ID: XF45E
LIMS ID: 13-19668
Matrix: Soil
Data Release Authorized:
Reported: 09/19/13

QC Report No: XF45-Landau Associates, Inc.
Project: Kaiser IA
118033.100.104
Date Sampled: 09/17/13
Date Received: 09/17/13

Date Extracted: 09/18/13
Date Analyzed: 09/18/13 20:52
Instrument/Analyst: NT6/JZ
GPC Cleanup: No
Alumina: No
Silica Gel: No

Sample Amount: 7.57 g-dry-wt
Final Extract Volume: 0.5 mL
Dilution Factor: 1.00
Percent Moisture: 5.7%

CAS Number	Analyte	RL	Result
56-55-3	Benzo(a)anthracene	66	< 66 U
218-01-9	Chrysene	66	< 66 U
50-32-8	Benzo(a)pyrene	66	< 66 U
193-39-5	Indeno(1,2,3-cd)pyrene	66	< 66 U
53-70-3	Dibenz(a,h)anthracene	66	< 66 U
TOTBFA	Total Benzofluoranthenes	66	< 66 U

Reported in µg/kg (ppb)

Semivolatile Surrogate Recovery

d14-p-Terphenyl	72.4%
2-Fluorobiphenyl	68.4%

ORGANICS ANALYSIS DATA SHEET

PNA's by SW8270D GC/MS

Page 1 of 1



Sample ID: SPL-21-20130917

SAMPLE

Lab Sample ID: XF45F

LIMS ID: 13-19669

Matrix: Soil

Data Release Authorized: *AS*

Reported: 09/19/13

QC Report No: XF45-Landau Associates, Inc.

Project: Kaiser IA

118033.100.104

Date Sampled: 09/17/13

Date Received: 09/17/13

Date Extracted: 09/18/13

Date Analyzed: 09/18/13 21:26

Instrument/Analyst: NT6/JZ

GPC Cleanup: No

Alumina: No

Silica Gel: No

Sample Amount: 7.57 g-dry-wt

Final Extract Volume: 0.5 mL

Dilution Factor: 1.00

Percent Moisture: 16.0%

CAS Number	Analyte	RL	Result
56-55-3	Benzo(a)anthracene	66	< 66 U
218-01-9	Chrysene	66	< 66 U
50-32-8	Benzo(a)pyrene	66	< 66 U
193-39-5	Indeno(1,2,3-cd)pyrene	66	< 66 U
53-70-3	Dibenz(a,h)anthracene	66	< 66 U
TOTBFA	Total Benzofluoranthenes	66	< 66 U

Reported in µg/kg (ppb)

Semivolatile Surrogate Recovery

d14-p-Terphenyl	70.0%
2-Fluorobiphenyl	64.4%

ORGANICS ANALYSIS DATA SHEET

PNA's by SW8270D GC/MS

Page 1 of 1

Sample ID: SPL-22-20130917

SAMPLE

Lab Sample ID: XF45G

LIMS ID: 13-19670

Matrix: Soil

Data Release Authorized: 

Reported: 09/19/13

QC Report No: XF45-Landau Associates, Inc.

Project: Kaiser IA

118033.100.104

Date Sampled: 09/17/13

Date Received: 09/17/13

Date Extracted: 09/18/13

Date Analyzed: 09/18/13 22:00

Instrument/Analyst: NT6/JZ

GPC Cleanup: No

Alumina: No

Silica Gel: No

Sample Amount: 8.15 g-dry-wt

Final Extract Volume: 0.5 mL

Dilution Factor: 1.00

Percent Moisture: 9.8%

CAS Number	Analyte	RL	Result
56-55-3	Benzo(a)anthracene	61	< 61 U
218-01-9	Chrysene	61	71
50-32-8	Benzo(a)pyrene	61	< 61 U
193-39-5	Indeno(1,2,3-cd)pyrene	61	< 61 U
53-70-3	Dibenz(a,h)anthracene	61	< 61 U
TOTBFA	Total Benzofluoranthenes	61	74

Reported in µg/kg (ppb)

Semivolatile Surrogate Recovery

d14-p-Terphenyl	69.6%
2-Fluorobiphenyl	62.4%

ORGANICS ANALYSIS DATA SHEET

PNA's by SW8270D GC/MS

Page 1 of 1

Sample ID: MB-091813

METHOD BLANK

Lab Sample ID: MB-091813

LIMS ID: 13-19664

Matrix: Soil

Data Release Authorized: *[Signature]*

Reported: 09/19/13

QC Report No: XF45-Landau Associates, Inc.

Project: Kaiser IA

118033.100.104

Date Sampled: NA

Date Received: NA

Date Extracted: 09/18/13

Date Analyzed: 09/18/13 16:56

Instrument/Analyst: NT6/JZ

GPC Cleanup: No

Alumina: No

Silica Gel: No

Sample Amount: 7.50 g-dry-wt

Final Extract Volume: 0.5 mL

Dilution Factor: 1.00

Percent Moisture: NA

CAS Number	Analyte	RL	Result
56-55-3	Benzo(a)anthracene	67	< 67 U
218-01-9	Chrysene	67	< 67 U
50-32-8	Benzo(a)pyrene	67	< 67 U
193-39-5	Indeno(1,2,3-cd)pyrene	67	< 67 U
53-70-3	Dibenz(a,h)anthracene	67	< 67 U
TOTBFA	Total Benzofluoranthenes	67	< 67 U

Reported in µg/kg (ppb)

Semivolatile Surrogate Recovery

d14-p-Terphenyl	80.4%
2-Fluorobiphenyl	65.6%

SW8270 PNA SURROGATE RECOVERY SUMMARY

Matrix: Soil

QC Report No: XF45-Landau Associates, Inc.
Project: Kaiser IA
118033.100.104

<u>Client ID</u>	<u>TER</u>	<u>FBP</u>	<u>TOT OUT</u>
MB-091813	80.4%	65.6%	0
LCS-091813	84.8%	67.2%	0
LCSD-091813	86.4%	66.0%	0
RML-1-20130917	69.6%	70.0%	0
RML-13-20130917	59.6%	61.2%	0
BF-1-20130917	62.0%	76.4%	0
BF-2-20130917	69.6%	64.8%	0
BF-3-20130917	72.4%	68.4%	0
SPL-21-20130917	70.0%	64.4%	0
SPL-22-20130917	69.6%	62.4%	0

	LCS/MB LIMITS	QC LIMITS
(TER) = d14-p-Terphenyl	(30-160)	(30-160)
(FBP) = 2-Fluorobiphenyl	(30-160)	(30-160)

Prep Method: SW3546
Log Number Range: 13-19664 to 13-19670

ORGANICS ANALYSIS DATA SHEET

PNA's by SW8270D GC/MS

Page 1 of 1

Sample ID: LCS-091813

LCS/LCSD

Lab Sample ID: LCS-091813

LIMS ID: 13-19664

Matrix: Soil

Data Release Authorized: *[Signature]*

Reported: 09/19/13

QC Report No: XF45-Landau Associates, Inc.

Project: Kaiser IA

118033.100.104

Date Sampled: NA

Date Received: 09/17/13

Date Extracted LCS/LCSD: 09/18/13

Sample Amount LCS: 7.50 g-dry-wt

LCSD: 7.50 g-dry-wt

Date Analyzed LCS: 09/18/13 17:30

Final Extract Volume LCS: 0.50 mL

LCSD: 09/18/13 18:03

LCSD: 0.50 mL

Instrument/Analyst LCS: NT6/JZ

Dilution Factor LCS: 1.00

LCSD: NT6/JZ

LCSD: 1.00

GPC Cleanup: No

Alumina Cleanup: No

Silica Gel Cleanup: No

Analyte	LCS	Spike Added-LCS	LCS Recovery	LCSD	Spike Added-LCSD	LCSD Recovery	RPD
Benzo(a)anthracene	1340	1670	80.2%	1380	1670	82.6%	2.9%
Chrysene	1350	1670	80.8%	1380	1670	82.6%	2.2%
Benzo(a)pyrene	1360	1670	81.4%	1390	1670	83.2%	2.2%
Indeno(1,2,3-cd)pyrene	1550	1670	92.8%	1610	1670	96.4%	3.8%
Dibenz(a,h)anthracene	1550	1670	92.8%	1600	1670	95.8%	3.2%
Total Benzofluoranthenes	2690	3330	80.8%	2770	3330	83.2%	2.9%

Semivolatile Surrogate Recovery

	LCS	LCSD
d14-p-Terphenyl	84.8%	86.4%
2-Fluorobiphenyl	67.2%	66.0%

Results reported in µg/kg

RPD calculated using sample concentrations per SW846.



Analytical Resources, Incorporated
Analytical Chemists and Consultants

September 20, 2013

Dave Fischer
Landau Associates, Inc.
950 Pacific Ave # 515
Tacoma, WA 98402

RE: Project: Kaiser IA
ARI Job No: XF64

Dear Dave:

Please find enclosed the original Chain-of-Custody (COC) record, sample receipt documentation, and the analytical results for the samples from the projects referenced above. Analytical Resources, Inc. (ARI) accepted two soil samples on September 18, 2013 in good condition. For further details regarding sample receipt, please refer to the enclosed Cooler Receipt Form.

The samples were analyzed for cPAHs, as requested on the COC.

No analytical complications were noted.

An electronic copy of this report and all associated raw data will remain on file with ARI. If you have any questions or require additional information, please feel free to contact me at your convenience.

Sincerely,
ANALYTICAL RESOURCES, INC.

A handwritten signature in black ink, appearing to read "Kelly Bottem".

Kelly Bottem
Client Services Manager
206/695-6211
kellyb@arilabs.com

Enclosures

1 of 13

- Seattle/Edmonds (425) 778-0907
- Tacoma (253) 926-2493
- Spokane (509) 327-9737
- Portland (503) 542-1080



Chain-of-Custody Record

Date 9/18/13
Page 1 of 1

Project Name Kaiser IA Project No. 118033.100.104
 Project Location/Event Kaiser, Port of Tacoma
 Sampler's Name DAR/DAM
 Project Contact Dave Fischer Stena Mark
 Send Results To Anna Halvorsen, Bill Evans, Dave Fischer

Sample I.D. Date Time Matrix Containers No. of

SPL-7-20130918 9/18/13 11:15 Soil 1 X
SPL-8-20130918 9/18/13 11:10 Soil 1 X

Testing Parameters

Turnaround Time
 Standard
 Accelerated
 1-2 Day TAT

Observations/Comments

- Allow water samples to settle, collect aliquot from clear portion
- NWTPH-Dx - run acid wash/silica gel cleanup
- run samples standardized to _____ product
- Analyze for EPH if no specific product identified
- VOC/BTEX/VPH (soil):
 - non-preserved
 - preserved w/methanol
 - preserved w/sodium bisulfate
 - Freeze upon receipt
- Dissolved metal water samples field filtered
- Other _____

Special Shipment/Handling or Storage Requirements Ice

Method of Shipment Carrier

Relinquished by
 Signature [Signature]
 Printed Name Don Mulkomsy
 Company LA
 Date 9/18/13 Time 1320

Received by
 Signature [Signature]
 Printed Name K. d. Hiden
 Company AR1
 Date 9/18/13 Time 1320

Relinquished by
 Signature _____
 Printed Name _____
 Company _____
 Date _____ Time _____

Received by
 Signature _____
 Printed Name _____
 Company _____
 Date _____ Time _____



Cooler Receipt Form

ARI Client: Landon

Project Name: Kaiser IA

COC No(s): _____ (NA)

Delivered by: Fed-Ex UPS Courier Hand Delivered Other: _____

Assigned ARI Job No: XFL4

Tracking No: _____ (NA)

Preliminary Examination Phase:

Were intact, properly signed and dated custody seals attached to the outside of to cooler? YES NO

Were custody papers included with the cooler? YES NO

Were custody papers properly filled out (ink, signed, etc.) YES NO

Temperature of Cooler(s) (°C) (recommended 2.0-6.0 °C for chemistry)..... 6.7

If cooler temperature is out of compliance fill out form 00070F

Temp Gun ID#: 90877952

Cooler Accepted by: [Signature] Date: 9/18/13 Time: 1320

Complete custody forms and attach all shipping documents

Log-In Phase:

Was a temperature blank included in the cooler? YES NO

What kind of packing material was used? ... Bubble Wrap Wet Ice Gel Packs Eggies Foam Block Paper Other: _____

Was sufficient ice used (if appropriate)? NA YES NO

Were all bottles sealed in individual plastic bags? YES NO

Did all bottles arrive in good condition (unbroken)? YES NO

Were all bottle labels complete and legible? YES NO

Did the number of containers listed on COC match with the number of containers received? YES NO

Did all bottle labels and tags agree with custody papers? YES NO

Were all bottles used correct for the requested analyses? YES NO

Do any of the analyses (bottles) require preservation? (attach preservation sheet, excluding VOCs)... (NA) YES NO

Were all VOC vials free of air bubbles? (NA) YES NO

Was sufficient amount of sample sent in each bottle? YES NO

Date VOC Trip Blank was made at ARI..... (NA)

Was Sample Split by ARI: NA YES Date/Time: _____ Equipment: _____ Split by: _____

Samples Logged by: AV Date: 9/18/13 Time: 1600

**** Notify Project Manager of discrepancies or concerns ****

Sample ID on Bottle	Sample ID on COC	Sample ID on Bottle	Sample ID on COC

Additional Notes, Discrepancies, & Resolutions:

By: _____ Date: _____

<p>Small Air Bubbles - 2mm</p>	<p>Peabubbles 2-4 mm</p>	<p>LARGE Air Bubbles > 4 mm</p>	Small → "sm" (< 2 mm)
			Peabubbles → "pb" (2 to <4 mm)
			Large → "lg" (4 to <6 mm)
			Headspace → "hs" (>6 mm)



Analytical Resources,
 Incorporated
 Analytical Chemists and
 Consultants

Cooler Temperature Compliance Form

Cooler#:	<u>1</u>	Temperature(°C):	<u>6.7</u>
Sample ID	Bottle Count	Bottle Type	
All samples received above 6°C.			

Cooler#:		Temperature(°C):	
Sample ID	Bottle Count	Bottle Type	

Cooler#:		Temperature(°C):	
Sample ID	Bottle Count	Bottle Type	

Cooler#:		Temperature(°C):	
Sample ID	Bottle Count	Bottle Type	

Completed by: AV Date: 9/18/13 Time: 1555

Sample ID Cross Reference Report



ARI Job No: XF64
Client: Landau Associates, Inc.
Project Event: 118033.100.104
Project Name: Kaiser IA

Sample ID	ARI Lab ID	ARI LIMS ID	Matrix	Sample Date/Time	VTSR
1. SPL-7-20130918	XF64A	13-19856	Soil	09/18/13 11:15	09/18/13 13:20
2. SPL-8-20130918	XF64B	13-19857	Soil	09/18/13 11:10	09/18/13 13:20



Data Reporting Qualifiers

Effective 2/14/2011

Inorganic Data

- U Indicates that the target analyte was not detected at the reported concentration
- * Duplicate RPD is not within established control limits
- B Reported value is less than the CRDL but \geq the Reporting Limit
- N Matrix Spike recovery not within established control limits
- NA Not Applicable, analyte not spiked
- H The natural concentration of the spiked element is so much greater than the concentration spiked that an accurate determination of spike recovery is not possible
- L Analyte concentration is ≤ 5 times the Reporting Limit and the replicate control limit defaults to ± 1 RL instead of the normal 20% RPD

Organic Data

- U Indicates that the target analyte was not detected at the reported concentration
- * Flagged value is not within established control limits
- B Analyte detected in an associated Method Blank at a concentration greater than one-half of ARI's Reporting Limit or 5% of the regulatory limit or 5% of the analyte concentration in the sample.
- J Estimated concentration when the value is less than ARI's established reporting limits
- D The spiked compound was not detected due to sample extract dilution
- E Estimated concentration calculated for an analyte response above the valid instrument calibration range. A dilution is required to obtain an accurate quantification of the analyte.
- Q Indicates a detected analyte with an initial or continuing calibration that does not meet established acceptance criteria ($< 20\%$ RSD, $< 20\%$ Drift or minimum RRF).



- S Indicates an analyte response that has saturated the detector. The calculated concentration is not valid; a dilution is required to obtain valid quantification of the analyte
- NA The flagged analyte was not analyzed for
- NR Spiked compound recovery is not reported due to chromatographic interference
- NS The flagged analyte was not spiked into the sample
- M Estimated value for an analyte detected and confirmed by an analyst but with low spectral match parameters. This flag is used only for GC-MS analyses
- M2 The sample contains PCB congeners that do not match any standard Aroclor pattern. The PCBs are identified and quantified as the Aroclor whose pattern most closely matches that of the sample. The reported value is an estimate.
- N The analysis indicates the presence of an analyte for which there is presumptive evidence to make a "tentative identification"
- Y The analyte is not detected at or above the reported concentration. The reporting limit is raised due to chromatographic interference. The Y flag is equivalent to the U flag with a raised reporting limit.
- EMPC Estimated Maximum Possible Concentration (EMPC) defined in EPA Statement of Work DLM02.2 as a value "calculated for 2,3,7,8-substituted isomers for which the quantitation and /or confirmation ion(s) has signal to noise in excess of 2.5, but does not meet identification criteria" **(Dioxin/Furan analysis only)**
- C The analyte was positively identified on only one of two chromatographic columns. Chromatographic interference prevented a positive identification on the second column
- P The analyte was detected on both chromatographic columns but the quantified values differ by $\geq 40\%$ RPD with no obvious chromatographic interference
- X Analyte signal includes interference from polychlorinated diphenyl ethers. **(Dioxin/Furan analysis only)**
- Z Analyte signal includes interference from the sample matrix or perfluorokerosene ions. **(Dioxin/Furan analysis only)**



Analytical Resources, Incorporated
Analytical Chemists and Consultants

Geotechnical Data

- A The total of all fines fractions. This flag is used to report total fines when only sieve analysis is requested and balances total grain size with sample weight.
- F Samples were frozen prior to particle size determination
- SM Sample matrix was not appropriate for the requested analysis. This normally refers to samples contaminated with an organic product that interferes with the sieving process and/or moisture content, porosity and saturation calculations
- SS Sample did not contain the proportion of "fines" required to perform the pipette portion of the grain size analysis
- W Weight of sample in some pipette aliquots was below the level required for accurate weighting

ORGANICS ANALYSIS DATA SHEET

PNAs by SW8270D GC/MS

Page 1 of 1

Sample ID: MB-091913

METHOD BLANK

Lab Sample ID: MB-091913

LIMS ID: 13-19856

Matrix: Soil

Data Release Authorized: *mw*

Reported: 09/20/13

QC Report No: XF64-Landau Associates, Inc.

Project: Kaiser IA

118033.100.104

Date Sampled: NA

Date Received: NA

Date Extracted: 09/19/13

Date Analyzed: 09/19/13 16:50

Instrument/Analyst: NT4/JZ

GPC Cleanup: No

Alumina: No

Silica Gel: No

Sample Amount: 7.50 g-dry-wt

Final Extract Volume: 0.5 mL

Dilution Factor: 1.00

Percent Moisture: NA

CAS Number	Analyte	RL	Result
56-55-3	Benzo(a)anthracene	67	< 67 U
218-01-9	Chrysene	67	< 67 U
50-32-8	Benzo(a)pyrene	67	< 67 U
193-39-5	Indeno(1,2,3-cd)pyrene	67	< 67 U
53-70-3	Dibenz(a,h)anthracene	67	< 67 U
TOTBFA	Total Benzofluoranthenes	67	< 67 U

Reported in µg/kg (ppb)

Semivolatiles Surrogate Recovery

d14-p-Terphenyl	88.0%
2-Fluorobiphenyl	64.8%

ORGANICS ANALYSIS DATA SHEET

PNAs by SW8270D GC/MS

Page 1 of 1

**Sample ID: SPL-7-20130918
SAMPLE**

Lab Sample ID: XF64A

LIMS ID: 13-19856

Matrix: Soil

Data Release Authorized: *TW*

Reported: 09/20/13

QC Report No: XF64-Landau Associates, Inc.

Project: Kaiser IA

118033.100.104

Date Sampled: 09/18/13

Date Received: 09/18/13

Date Extracted: 09/19/13

Date Analyzed: 09/19/13 19:20

Instrument/Analyst: NT4/JZ

GPC Cleanup: No

Alumina: No

Silica Gel: No

Sample Amount: 7.80 g-dry-wt

Final Extract Volume: 0.5 mL

Dilution Factor: 1.00

Percent Moisture: 13.5%

CAS Number	Analyte	RL	Result
56-55-3	Benzo (a) anthracene	64	94
218-01-9	Chrysene	64	180
50-32-8	Benzo (a) pyrene	64	< 64 U
193-39-5	Indeno (1,2,3-cd) pyrene	64	< 64 U
53-70-3	Dibenz (a,h) anthracene	64	< 64 U
TOTBFA	Total Benzofluoranthenes	64	150

Reported in µg/kg (ppb)

Semivolatile Surrogate Recovery

d14-p-Terphenyl	74.4%
2-Fluorobiphenyl	65.6%

ORGANICS ANALYSIS DATA SHEET

PNAs by SW8270D GC/MS

Page 1 of 1

**Sample ID: SPL-8-20130918
SAMPLE**

Lab Sample ID: XF64B
LIMS ID: 13-19857
Matrix: Soil
Data Release Authorized: *mw*
Reported: 09/20/13

QC Report No: XF64-Landau Associates, Inc.
Project: Kaiser IA
118033.100.104
Date Sampled: 09/18/13
Date Received: 09/18/13

Date Extracted: 09/19/13
Date Analyzed: 09/19/13 19:50
Instrument/Analyst: NT4/JZ
GPC Cleanup: No
Alumina: No
Silica Gel: No

Sample Amount: 7.71 g-dry-wt
Final Extract Volume: 0.5 mL
Dilution Factor: 1.00
Percent Moisture: 4.4%

CAS Number	Analyte	RL	Result
56-55-3	Benzo(a)anthracene	65	< 65 U
218-01-9	Chrysene	65	< 65 U
50-32-8	Benzo(a)pyrene	65	< 65 U
193-39-5	Indeno(1,2,3-cd)pyrene	65	< 65 U
53-70-3	Dibenz(a,h)anthracene	65	< 65 U
TOTBFA	Total Benzofluoranthenes	65	< 65 U

Reported in µg/kg (ppb)

Semivolatile Surrogate Recovery

d14-p-Terphenyl	74.4%
2-Fluorobiphenyl	59.6%

SW8270 PNA SURROGATE RECOVERY SUMMARY

Matrix: Soil

QC Report No: XF64-Landau Associates, Inc.
Project: Kaiser IA
118033.100.104

<u>Client ID</u>	<u>TER</u>	<u>FBP</u>	<u>TOT OUT</u>
MB-091913	88.0%	64.8%	0
LCS-091913	82.8%	58.8%	0
LCSD-091913	79.2%	62.8%	0
SPL-7-20130918	74.4%	65.6%	0
SPL-8-20130918	74.4%	59.6%	0

LCS/MB LIMITS QC LIMITS

(TER) = d14-p-Terphenyl (30-160) (30-160)
(FBP) = 2-Fluorobiphenyl (30-160) (30-160)

Prep Method: SW3546
Log Number Range: 13-19856 to 13-19857

ORGANICS ANALYSIS DATA SHEET

PNAs by SW8270D GC/MS

Page 1 of 1

Sample ID: LCS-091913

LCS/LCSD

Lab Sample ID: LCS-091913

LIMS ID: 13-19856

Matrix: Soil

Data Release Authorized: *MW*

Reported: 09/20/13

QC Report No: XF64-Landau Associates, Inc.

Project: Kaiser IA

118033.100.104

Date Sampled: NA

Date Received: 09/18/13

Date Extracted LCS/LCSD: 09/19/13

Sample Amount LCS: 7.50 g-dry-wt

LCSD: 7.50 g-dry-wt

Date Analyzed LCS: 09/19/13 17:20

Final Extract Volume LCS: 0.50 mL

LCSD: 09/19/13 17:50

LCSD: 0.50 mL

Instrument/Analyst LCS: NT4/JZ

Dilution Factor LCS: 1.00

LCSD: NT4/JZ

LCSD: 1.00

GPC Cleanup: No

Alumina Cleanup: No

Silica Gel Cleanup: No

Analyte	Spike		LCS		Spike		LCSD	
	LCS	Added-LCS	Recovery	LCSD	Added-LCSD	Recovery	RPD	
Benzo(a)anthracene	1110	1670	66.5%	1080	1670	64.7%	2.7%	
Chrysene	1100	1670	65.9%	1010	1670	60.5%	8.5%	
Benzo(a)pyrene	1030	1670	61.7%	963	1670	57.7%	6.7%	
Indeno(1,2,3-cd)pyrene	1280	1670	76.6%	1230	1670	73.7%	4.0%	
Dibenz(a,h)anthracene	1340	1670	80.2%	1280	1670	76.6%	4.6%	
Total Benzofluoranthenes	2400	3330	72.1%	2300	3330	69.1%	4.3%	

Semivolatile Surrogate Recovery

	LCS	LCSD
d14-p-Terphenyl	82.8%	79.2%
2-Fluorobiphenyl	58.8%	62.8%

Results reported in µg/kg

RPD calculated using sample concentrations per SW846.



Analytical Resources, Incorporated
Analytical Chemists and Consultants

September 25, 2013

Dave Pischer
Landau Associates, Inc.
950 Pacific Ave # 515
Tacoma, WA 98402

RE: Project: Kaiser IA
ARI Job No: XG00

Dear Dave:

Please find enclosed the original Chain-of-Custody (COC) record, sample receipt documentation, and the analytical results for the samples from the projects referenced above. Analytical Resources, Inc. (ARI) accepted four soil samples on September 20, 2013 in good condition. For further details regarding sample receipt, please refer to the enclosed Cooler Receipt Form.

The samples were analyzed for cPAHs, as requested on the COC.

No analytical complications were noted.

An electronic copy of this report and all associated raw data will remain on file with ARI. If you have any questions or require additional information, please feel free to contact me at your convenience.

Sincerely,
ANALYTICAL RESOURCES, INC.

Kelly Bottem
Client Services Manager
206/695-6211
kellyb@arilabs.com

Enclosures

1 of 12

- Seattle/Edmonds (425) 778-0907
- Tacoma (253) 926-2493
- Spokane (509) 327-9737
- Portland (503) 542-1080



Chain-of-Custody Record

Date 9/20/2013
Page 1 of 1

Project Name Kaiser IA Project No. 118033.100.104
 Project Location/Event Kaiser Port of Tacoma
 Sampler's Name DAR / DAM
 Project Contact Dave Fischer Sierra Mott
 Send Results To Anne Halvorsen, Bill Evans, Dave Fischer

Testing Parameters

Turnaround Time
 Standard
 Accelerated
 1-2 Day TAT

Sample I.D.	Date	Time	Matrix	No. of Containers	Observations/Comments
SPL-11-20130920	9/20/13	9:40	Soil	1	X Allow water samples to settle, collect aliquot from clear portion
SPL-12-20130920	9/20/13	9:42	Soil	1	X NWTPH-Dx - run acid wash/silica gel cleanup
SPL-14-20130920	9/20/13	9:30	Soil	1	run samples standardized to product
SPL-18-20130920	9/20/13	9:35	Soil	1	Analyze for EPH if no specific product identified
					VOC/BTEX/VPH (soil):
					non-preserved
					preserved w/methanol
					preserved w/sodium bisulfate
					Freeze upon receipt
					Dissolved metal water samples field filtered
					Other

Special Shipment/Handling or Storage Requirements Ice Method of Shipment Courier

Relinquished by Signature <u>[Signature]</u> Printed Name <u>Sierra Mott</u> Company <u>Landau Associates</u> Date <u>9/20/13</u> Time <u>12:22</u>	Received by Signature <u>[Signature]</u> Printed Name <u>Sierra Mott</u> Company <u>Landau Associates</u> Date <u>9/20/13</u> Time <u>1612</u>
Relinquished by Signature <u>[Signature]</u> Printed Name <u>Sierra Mott</u> Company <u>Landau Associates</u> Date <u>9/20/13</u> Time <u>1612</u>	Received by Signature <u>[Signature]</u> Printed Name <u>Sierra Mott</u> Company <u>Landau Associates</u> Date <u>9/20/13</u> Time <u>1612</u>



Cooler Receipt Form

ARI Client: London

Project Name: Kaiser Port of Tacoma

COC No(s): _____ (NA)

Delivered by: Fed-Ex UPS Courier (circled) Hand Delivered Other: _____

Assigned ARI Job No: XG700

Tracking No: _____ (NA)

Preliminary Examination Phase:

Were intact, properly signed and dated custody seals attached to the outside of to cooler? YES (circled) NO (circled)

Were custody papers included with the cooler? YES (circled) NO

Were custody papers properly filled out (ink, signed, etc.) YES (circled) NO

Temperature of Cooler(s) (°C) (recommended 2.0-6.0 °C for chemistry)
Time: 1645 8.3

If cooler temperature is out of compliance fill out form 00070F Temp Gun ID#: 90977952

Cooler Accepted by: (Signature) Date: 9/20/13 Time: 1612

Complete custody forms and attach all shipping documents

Log-In Phase:

Was a temperature blank included in the cooler? YES (circled) NO (circled)

What kind of packing material was used? .. Bubble Wrap (circled) Wet Ice Gel Packs Baggies Foam Block Paper Other: _____

Was sufficient ice used (if appropriate)? NA YES (circled) NO (circled)

Were all bottles sealed in individual plastic bags? YES (circled) NO (circled)

Did all bottles arrive in good condition (unbroken)? YES (circled) NO

Were all bottle labels complete and legible? YES (circled) NO

Did the number of containers listed on COC match with the number of containers received? YES (circled) NO

Did all bottle labels and tags agree with custody papers? YES (circled) NO

Were all bottles used correct for the requested analyses? YES (circled) NO

Do any of the analyses (bottles) require preservation? (attach preservation sheet, excluding VOCs) NA (circled) YES NO

Were all VOC vials free of air bubbles? NA (circled) YES NO

Was sufficient amount of sample sent in each bottle? YES (circled) NO

Date VOC Trip Blank was made at ARI. NA (circled)

Was Sample Split by ARI (NA circled) YES Date/Time: _____ Equipment: _____ Split by: _____

Samples Logged by: JM Date: 9/20/13 Time: 1710

**** Notify Project Manager of discrepancies or concerns ****

Sample ID on Bottle	Sample ID on COC	Sample ID on Bottle	Sample ID on COC

Additional Notes, Discrepancies, & Resolutions:

By: _____ Date: _____

<p>Small Air Bubbles - 2mm</p>	<p>Peabubbles 2-4 mm</p>	<p>LARGE Air Bubbles > 4 mm</p>	<p>Small → "sm" (< 2 mm)</p> <p>Peabubbles → "pb" (2 to < 4 mm)</p> <p>Large → "lg" (4 to < 6 mm)</p> <p>Headspace → "hs" (> 6 mm)</p>
------------------------------------	------------------------------	--	--

Sample ID Cross Reference Report



ARI Job No: XG00
Client: Landau Associates, Inc.
Project Event: 118033.100.104
Project Name: Kaiser Port of Tacoma

Sample ID	ARI Lab ID	ARI LIMS ID	Matrix	Sample Date/Time	VTSR
1. SPL-11-20130920	XG00A	13-20205	Soil	09/20/13 09:40	09/20/13 16:12
2. SPL-12-20130920	XG00B	13-20206	Soil	09/20/13 09:42	09/20/13 16:12
3. SPL-14-20130920	XG00C	13-20207	Soil	09/20/13 09:30	09/20/13 16:12
4. SPL-18-20130920	XG00D	13-20208	Soil	09/20/13 09:35	09/20/13 16:12



Cooler Temperature Compliance Form

XG00 8.3

Cooler#: 1 Temperature(°C): 8.3

Sample ID	Bottle Count	Bottle Type
Samples recieved above 6°C		

Cooler#: _____ Temperature(°C): _____

Sample ID	Bottle Count	Bottle Type

Cooler#: _____ Temperature(°C): _____

Sample ID	Bottle Count	Bottle Type

Cooler#: _____ Temperature(°C): _____

Sample ID	Bottle Count	Bottle Type

Completed by: JM Date: 9/20/13 Time: 1710

ORGANICS ANALYSIS DATA SHEET
PNAs by SW8270D GC/MS
 Page 1 of 1

Sample ID: SPL-11-20130920
SAMPLE

Lab Sample ID: XG00A
 LIMS ID: 13-20205
 Matrix: Soil
 Data Release Authorized: *[Signature]*
 Reported: 09/25/13

QC Report No: XG00-Landau Associates, Inc.
 Project: Kaiser Port of Tacoma
 118033.100.104
 Date Sampled: 09/20/13
 Date Received: 09/20/13

Date Extracted: 09/24/13
 Date Analyzed: 09/24/13 17:37
 Instrument/Analyst: NT6/JZ
 GPC Cleanup: No
 Alumina: No
 Silica Gel: No

Sample Amount: 8.23 g-dry-wt
 Final Extract Volume: 0.5 mL
 Dilution Factor: 1.00
 Percent Moisture: 9.0%

CAS Number	Analyte	RL	Result
56-55-3	Benzo(a)anthracene	61	< 61 U
218-01-9	Chrysene	61	< 61 U
50-32-8	Benzo(a)pyrene	61	< 61 U
193-39-5	Indeno(1,2,3-cd)pyrene	61	< 61 U
53-70-3	Dibenz(a,h)anthracene	61	< 61 U
TOTBFA	Total Benzofluoranthenes	61	< 61 U

Reported in µg/kg (ppb)

Semivolatile Surrogate Recovery

d14-p-Terphenyl	69.6%
2-Fluorobiphenyl	60.4%

ORGANICS ANALYSIS DATA SHEET

PNAs by SW8270D GC/MS

Page 1 of 1

Sample ID: SPL-12-20130920

SAMPLE

Lab Sample ID: XG00B

LIMS ID: 13-20206

Matrix: Soil

Data Release Authorized: 

Reported: 09/25/13

QC Report No: XG00-Landau Associates, Inc.

Project: Kaiser Port of Tacoma

118033.100.104

Date Sampled: 09/20/13

Date Received: 09/20/13

Date Extracted: 09/24/13

Date Analyzed: 09/24/13 18:11

Instrument/Analyst: NT6/JZ

GPC Cleanup: No

Alumina: No

Silica Gel: No

Sample Amount: 7.93 g-dry-wt

Final Extract Volume: 0.5 mL

Dilution Factor: 1.00

Percent Moisture: 21.1%

CAS Number	Analyte	RL	Result
56-55-3	Benzo(a)anthracene	63	< 63 U
218-01-9	Chrysene	63	< 63 U
50-32-8	Benzo(a)pyrene	63	< 63 U
193-39-5	Indeno(1,2,3-cd)pyrene	63	< 63 U
53-70-3	Dibenz(a,h)anthracene	63	< 63 U
TOTBFA	Total Benzofluoranthenes	63	69

Reported in µg/kg (ppb)

Semivolatile Surrogate Recovery

d14-p-Terphenyl	54.8%
2-Fluorobiphenyl	56.0%

ORGANICS ANALYSIS DATA SHEET
PNA's by SW8270D GC/MS
 Page 1 of 1

Sample ID: SPL-14-20130920
SAMPLE

Lab Sample ID: XG00C
 LIMS ID: 13-20207
 Matrix: Soil
 Data Release Authorized: 
 Reported: 09/25/13

QC Report No: XG00-Landau Associates, Inc.
 Project: Kaiser Port of Tacoma
 118033.100.104
 Date Sampled: 09/20/13
 Date Received: 09/20/13

Date Extracted: 09/24/13
 Date Analyzed: 09/24/13 18:45
 Instrument/Analyst: NT6/JZ
 GPC Cleanup: No
 Alumina: No
 Silica Gel: No

Sample Amount: 7.92 g-dry-wt
 Final Extract Volume: 0.5 mL
 Dilution Factor: 1.00
 Percent Moisture: 28.0%

CAS Number	Analyte	RL	Result
56-55-3	Benzo (a) anthracene	63	810
218-01-9	Chrysene	63	1,400
50-32-8	Benzo (a) pyrene	63	680
193-39-5	Indeno (1,2,3-cd) pyrene	63	390
53-70-3	Dibenz (a,h) anthracene	63	170
TOTBFA	Total Benzofluoranthenes	63	1,600

Reported in µg/kg (ppb)

Semivolatile Surrogate Recovery

d14-p-Terphenyl	47.2%
2-Fluorobiphenyl	53.6%

ORGANICS ANALYSIS DATA SHEET
PNA's by SW8270D GC/MS
 Page 1 of 1

Sample ID: SPL-18-20130920
SAMPLE

Lab Sample ID: XG00D
 LIMS ID: 13-20208
 Matrix: Soil
 Data Release Authorized: *AB*
 Reported: 09/25/13

QC Report No: XG00-Landau Associates, Inc.
 Project: Kaiser Port of Tacoma
 118033.100.104
 Date Sampled: 09/20/13
 Date Received: 09/20/13

Date Extracted: 09/24/13
 Date Analyzed: 09/24/13 19:19
 Instrument/Analyst: NT6/JZ
 GPC Cleanup: No
 Alumina: No
 Silica Gel: No

Sample Amount: 7.71 g-dry-wt
 Final Extract Volume: 0.5 mL
 Dilution Factor: 1.00
 Percent Moisture: 3.8%

CAS Number	Analyte	RL	Result
56-55-3	Benzo(a)anthracene	65	< 65 U
218-01-9	Chrysene	65	< 65 U
50-32-8	Benzo(a)pyrene	65	< 65 U
193-39-5	Indeno(1,2,3-cd)pyrene	65	< 65 U
53-70-3	Dibenz(a,h)anthracene	65	< 65 U
TOTBFA	Total Benzofluoranthenes	65	< 65 U

Reported in µg/kg (ppb)

Semivolatile Surrogate Recovery

d14-p-Terphenyl	60.4%
2-Fluorobiphenyl	54.4%

ORGANICS ANALYSIS DATA SHEET

PNA's by SW8270D GC/MS

Page 1 of 1

Sample ID: MB-092413

METHOD BLANK

Lab Sample ID: MB-092413

LIMS ID: 13-20205

Matrix: Soil

Data Release Authorized: *AB*

Reported: 09/25/13

QC Report No: XG00-Landau Associates, Inc.

Project: Kaiser Port of Tacoma

118033.100.104

Date Sampled: NA

Date Received: NA

Date Extracted: 09/24/13

Date Analyzed: 09/24/13 15:55

Instrument/Analyst: NT6/JZ

GPC Cleanup: No

Alumina: No

Silica Gel: No

Sample Amount: 7.50 g-dry-wt

Final Extract Volume: 0.5 mL

Dilution Factor: 1.00

Percent Moisture: NA

CAS Number	Analyte	RL	Result
56-55-3	Benzo(a)anthracene	67	< 67 U
218-01-9	Chrysene	67	< 67 U
50-32-8	Benzo(a)pyrene	67	< 67 U
193-39-5	Indeno(1,2,3-cd)pyrene	67	< 67 U
53-70-3	Dibenz(a,h)anthracene	67	< 67 U
TOTBFA	Total Benzofluoranthenes	67	< 67 U

Reported in µg/kg (ppb)

Semivolatile Surrogate Recovery

d14-p-Terphenyl	77.6%
2-Fluorobiphenyl	60.0%

SW8270 PNA SURROGATE RECOVERY SUMMARY

Matrix: Soil

QC Report No: XG00-Landau Associates, Inc.
Project: Kaiser Port of Tacoma
118033.100.104

<u>Client ID</u>	<u>TER</u>	<u>FBP</u>	<u>TOT OUT</u>
MB-092413	77.6%	60.0%	0
LCS-092413	77.6%	63.6%	0
LCSD-092413	76.4%	60.4%	0
SPL-11-20130920	69.6%	60.4%	0
SPL-12-20130920	54.8%	56.0%	0
SPL-14-20130920	47.2%	53.6%	0
SPL-18-20130920	60.4%	54.4%	0

LCS/MB LIMITS QC LIMITS

(TER) = d14-p-Terphenyl (30-160) (30-160)
(FBP) = 2-Fluorobiphenyl (30-160) (30-160)

Prep Method: SW3546
Log Number Range: 13-20205 to 13-20208

ORGANICS ANALYSIS DATA SHEET
PNA's by SW8270D GC/MS
 Page 1 of 1

Sample ID: LCS-092413
LCS/LCSD

Lab Sample ID: LCS-092413
 LIMS ID: 13-20205
 Matrix: Soil
 Data Release Authorized: *AS*
 Reported: 09/25/13

QC Report No: XG00-Landau Associates, Inc.
 Project: Kaiser Port of Tacoma
 118033.100.104
 Date Sampled: NA
 Date Received: 09/20/13

Date Extracted LCS/LCSD: 09/24/13

Sample Amount LCS: 7.50 g-dry-wt
 LCSD: 7.50 g-dry-wt

Date Analyzed LCS: 09/24/13 16:29
 LCSD: 09/24/13 17:03

Final Extract Volume LCS: 0.50 mL
 LCSD: 0.50 mL

Instrument/Analyst LCS: NT6/JZ
 LCSD: NT6/JZ

Dilution Factor LCS: 1.00
 LCSD: 1.00

GPC Cleanup: No
 Silica Gel Cleanup: No

Alumina Cleanup: No

Analyte	Spike		LCS		Spike		LCSD		RPD
	LCS	Added-LCS	Recovery	LCSD	Added-LCSD	Recovery	RPD		
Benzo(a)anthracene	1210	1670	72.5%	1200	1670	71.9%	0.8%		
Chrysene	1220	1670	73.1%	1200	1670	71.9%	1.7%		
Benzo(a)pyrene	1210	1670	72.5%	1180	1670	70.7%	2.5%		
Indeno(1,2,3-cd)pyrene	1330	1670	79.6%	1330	1670	79.6%	0.0%		
Dibenz(a,h)anthracene	1370	1670	82.0%	1350	1670	80.8%	1.5%		
Total Benzofluoranthenes	2660	3330	79.9%	2550	3330	76.6%	4.2%		

Semivolatile Surrogate Recovery

	LCS	LCSD
d14-p-Terphenyl	77.6%	76.4%
2-Fluorobiphenyl	63.6%	60.4%

Results reported in µg/kg
 RPD calculated using sample concentrations per SW846.



Analytical Resources, Incorporated
Analytical Chemists and Consultants

September 30, 2013

Dave Fischer
Landau Associates, Inc.
950 Pacific Ave # 515
Tacoma, WA 98402

RE: Project: Kaiser IA
ARI Job No: XH06

Dear Dave:

Please find enclosed the original Chain-of-Custody (COC) record, sample receipt documentation, and the analytical results for the samples from the projects referenced above. Analytical Resources, Inc. (ARI) accepted three soil samples on September 27, 2013 in good condition. For further details regarding sample receipt, please refer to the enclosed Cooler Receipt Form.

The samples were analyzed for cPAHs, as requested on the COC.

No analytical complications were noted.

An electronic copy of this report and all associated raw data will remain on file with ARI. If you have any questions or require additional information, please feel free to contact me at your convenience.

Sincerely,
ANALYTICAL RESOURCES, INC.

A handwritten signature in black ink, appearing to read "Kelly Bottem".

Kelly Bottem
Client Services Manager
206/695-6211
kellyb@arilabs.com

Enclosures

1 of 11

XH106

Chain-of-Custody Record

Project Name <u>Kaiser IA</u> Project No. <u>118033.100.104</u> Project Location/Event <u>Kaiser Port of Tacoma</u> Sampler's Name <u>DAR / DAM</u> Project Contact <u>Dave Fischer</u> Send Results To <u>Sierra Matt, Bill Evans, Dave Fischer</u>						Turnaround Time <input type="checkbox"/> Standard <input type="checkbox"/> Accelerated <input checked="" type="checkbox"/> <u>1-2 Day TAT</u>						
Testing Parameters						Observations/Comments						
Sample I.D.	Date	Time	Matrix	No. of Containers								
<u>SPL-23-20130927</u>	<u>9/27/13</u>	<u>8:15</u>	<u>Soil</u>	<u>1</u>	<u>X</u>							<u>X</u> Allow water samples to settle, collect aliquot from clear portion
<u>SPL-24-20130927</u>	<u>↓</u>	<u>8:30</u>	<u>↓</u>	<u>1</u>	<u>X</u>							<u>X</u> NWTPH-Dx - run acid wash/silica gel cleanup
<u>SPL-25-20130927</u>		<u>8:40</u>		<u>1</u>	<u>X</u>							__ run samples standardized to _____ product
												__ Analyze for EPH if no specific product identified
												VOC/BTEX/VPH (soil):
												__ non-preserved
												__ preserved w/methanol
												__ preserved w/sodium bisulfate
												__ Freeze upon receipt
												__ Dissolved metal water samples field filtered
												Other _____
Special Shipment/Handling or Storage Requirements <u>On Ice</u>						Method of Shipment <u>Courier</u>						
Relinquished by <u>[Signature]</u> Signature <u>Don Mulkoms</u> Printed Name <u>DAM</u> Company <u>LAH</u> Date <u>9/27/13</u> Time <u>1215</u>		Received by <u>[Signature]</u> Signature <u>Rick Hudson</u> Printed Name <u>ARI</u> Company _____ Date <u>9/27/13</u> Time <u>1215</u>		Relinquished by Signature _____ Printed Name _____ Company _____ Date _____ Time _____		Received by Signature _____ Printed Name _____ Company _____ Date _____ Time _____						



Cooler Receipt Form

ARI Client Landon

Project Name Kaiser IA

COC No(s) _____ (NA)

Delivered by Fed-Ex UPS Courier Hand Delivered Other: _____

Assigned ARI Job No. XH06

Tracking No: _____ (NA)

Preliminary Examination Phase:

Were intact, properly signed and dated custody seals attached to the outside of to cooler? YES NO

Were custody papers included with the cooler? YES NO

Were custody papers properly filled out (ink, signed, etc.) YES NO

Temperature of Cooler(s) (°C) (recommended 2.0-6.0 °C for chemistry) _____

Time 14:00 _____

If cooler temperature is out of compliance fill out form 00070F

Cooler Accepted by [Signature] Date 9/27/13 Time: 1215 Temp Gun ID# 90877952

Complete custody forms and attach all shipping documents

Log-In Phase:

Was a temperature blank included in the cooler? YES NO

What kind of packing material was used? ... Bubble Wrap Wet Ice Gel Packs Baggies Foam Block Paper Other _____

Was sufficient ice used (if appropriate)? NA YES NO

Were all bottles sealed in individual plastic bags? YES NO

Did all bottles arrive in good condition (unbroken)? YES NO

Were all bottle labels complete and legible? YES NO

Did the number of containers listed on COC match with the number of containers received? YES NO

Did all bottle labels and tags agree with custody papers? YES NO

Were all bottles used correct for the requested analyses? YES NO

Do any of the analyses (bottles) require preservation? (attach preservation sheet, excluding VOCs) .. NA YES NO

Were all VOC vials free of air bubbles? NA YES NO

Was sufficient amount of sample sent in each bottle? YES NO

Date VOC Trip Blank was made at ARI: NA

Was Sample Split by ARI: NA YES Date/Time: _____ Equipment: _____ Split by: _____

Samples Logged by AV Date: 9/27/13 Time: 1520

**** Notify Project Manager of discrepancies or concerns ****

Sample ID on Bottle	Sample ID on COC	Sample ID on Bottle	Sample ID on COC

Additional Notes, Discrepancies, & Resolutions:

By: _____ Date: _____



Small → "sm" (< 2 mm)
Peabubbles → "pb" (2 to < 4 mm)
Large → "lg" (4 to < 6 mm)
Headspace → "hs" (> 6 mm)

Sample ID Cross Reference Report



ARI Job No: XH06
Client: Landau Associates, Inc.
Project Event: 118033.100.104
Project Name: Kaiser IA

Sample ID	ARI Lab ID	ARI LIMS ID	Matrix	Sample Date/Time	VTSR
1. SPL-23-20130927	XH06A	13-20993	Soil	09/27/13 08:15	09/27/13 12:15
2. SPL-24-20130927	XH06B	13-20994	Soil	09/27/13 08:30	09/27/13 12:15
3. SPL-25-20130927	XH06C	13-20995	Soil	09/27/13 08:40	09/27/13 12:15

ORGANICS ANALYSIS DATA SHEET

PNAs by SW8270D GC/MS

Page 1 of 1

Sample ID: SPL-23-20130927

SAMPLE

Lab Sample ID: XH06A

LIMS ID: 13-20993

Matrix: Soil

Data Release Authorized: 

Reported: 09/30/13

QC Report No: XH06-Landau Associates, Inc.

Project: Kaiser IA

118033.100.104

Date Sampled: 09/27/13

Date Received: 09/27/13

Date Extracted: 09/27/13

Date Analyzed: 09/27/13 21:40

Instrument/Analyst: NT8/JZ

GPC Cleanup: No

Alumina: No

Silica Gel: No

Sample Amount: 10.1 g-dry-wt

Final Extract Volume: 0.5 mL

Dilution Factor: 1.00

Percent Moisture: 16.0%

CAS Number	Analyte	RL	Result
56-55-3	Benzo(a)anthracene	50	< 50 U
218-01-9	Chrysene	50	67
50-32-8	Benzo(a)pyrene	50	< 50 U
193-39-5	Indeno(1,2,3-cd)pyrene	50	< 50 U
53-70-3	Dibenz(a,h)anthracene	50	< 50 U
TOTBFA	Total Benzofluoranthenes	50	59

Reported in µg/kg (ppb)

Semivolatile Surrogate Recovery

d14-p-Terphenyl	72.0%
2-Fluorobiphenyl	66.0%

ORGANICS ANALYSIS DATA SHEET

PNAs by SW8270D GC/MS

Page 1 of 1

**Sample ID: SPL-24-20130927
SAMPLE**

Lab Sample ID: XH06B
LIMS ID: 13-20994
Matrix: Soil
Data Release Authorized: 
Reported: 09/30/13

QC Report No: XH06-Landau Associates, Inc.
Project: Kaiser IA
118033.100.104
Date Sampled: 09/27/13
Date Received: 09/27/13

Date Extracted: 09/27/13
Date Analyzed: 09/27/13 22:08
Instrument/Analyst: NT8/JZ
GPC Cleanup: No
Alumina: No
Silica Gel: No

Sample Amount: 10.6 g-dry-wt
Final Extract Volume: 0.5 mL
Dilution Factor: 1.00
Percent Moisture: 11.6%

CAS Number	Analyte	RL	Result
56-55-3	Benzo (a) anthracene	47	1,600
218-01-9	Chrysene	47	3,800 ES
50-32-8	Benzo (a) pyrene	47	1,100
193-39-5	Indeno (1,2,3-cd) pyrene	47	680
53-70-3	Dibenz (a,h) anthracene	47	220
TOTBFA	Total Benzofluoranthenes	47	3,000

Reported in µg/kg (ppb)

Semivolatile Surrogate Recovery

d14-p-Terphenyl	82.0%
2-Fluorobiphenyl	79.2%

ORGANICS ANALYSIS DATA SHEET

PNAs by SW8270D GC/MS

Page 1 of 1

**Sample ID: SPL-24-20130927
DILUTION**

Lab Sample ID: XH06B

LIMS ID: 13-20994

Matrix: Soil

Data Release Authorized: 

Reported: 09/30/13

QC Report No: XH06-Landau Associates, Inc.

Project: Kaiser IA

118033.100.104

Date Sampled: 09/27/13

Date Received: 09/27/13

Date Extracted: 09/27/13

Date Analyzed: 09/30/13 11:58

Instrument/Analyst: NT8/JZ

GPC Cleanup: No

Alumina: No

Silica Gel: No

Sample Amount: 10.6 g-dry-wt

Final Extract Volume: 0.5 mL

Dilution Factor: 3.00

Percent Moisture: 11.6%

CAS Number	Analyte	RL	Result
56-55-3	Benzo (a) anthracene	140	1,600
218-01-9	Chrysene	140	4,000
50-32-8	Benzo (a) pyrene	140	1,000
193-39-5	Indeno (1,2,3-cd) pyrene	140	750
53-70-3	Dibenz (a,h) anthracene	140	230
TOTBFA	Total Benzofluoranthenes	140	3,000

Reported in µg/kg (ppb)

Semivolatile Surrogate Recovery

d14-p-Terphenyl	88.9%
2-Fluorobiphenyl	83.0%

ORGANICS ANALYSIS DATA SHEET

PNAs by SW8270D GC/MS

Page 1 of 1

Sample ID: SPL-25-20130927

SAMPLE

Lab Sample ID: XH06C

LIMS ID: 13-20995

Matrix: Soil

Data Release Authorized: 

Reported: 09/30/13

QC Report No: XH06-Landau Associates, Inc.

Project: Kaiser IA

118033.100.104

Date Sampled: 09/27/13

Date Received: 09/27/13

Date Extracted: 09/27/13

Date Analyzed: 09/27/13 22:37

Instrument/Analyst: NT8/JZ

GPC Cleanup: No

Alumina: No

Silica Gel: No

Sample Amount: 9.55 g-dry-wt

Final Extract Volume: 0.5 mL

Dilution Factor: 1.00

Percent Moisture: 20.4%

CAS Number	Analyte	RL	Result
56-55-3	Benzo(a)anthracene	52	< 52 U
218-01-9	Chrysene	52	87
50-32-8	Benzo(a)pyrene	52	< 52 U
193-39-5	Indeno(1,2,3-cd)pyrene	52	< 52 U
53-70-3	Dibenz(a,h)anthracene	52	< 52 U
TOTBFA	Total Benzofluoranthenes	52	65

Reported in µg/kg (ppb)

Semivolatile Surrogate Recovery

d14-p-Terphenyl	61.6%
2-Fluorobiphenyl	63.2%

ORGANICS ANALYSIS DATA SHEET
PNAs by SW8270D GC/MS
 Page 1 of 1

Sample ID: MB-092713
METHOD BLANK

Lab Sample ID: MB-092713
 LIMS ID: 13-20993
 Matrix: Soil
 Data Release Authorized: *[Signature]*
 Reported: 09/30/13

QC Report No: XH06-Landau Associates, Inc.
 Project: Kaiser IA
 118033.100.104
 Date Sampled: NA
 Date Received: NA

Date Extracted: 09/27/13
 Date Analyzed: 09/27/13 20:16
 Instrument/Analyst: NT8/JZ
 GPC Cleanup: No
 Alumina: No
 Silica Gel: No

Sample Amount: 7.50 g-dry-wt
 Final Extract Volume: 0.5 mL
 Dilution Factor: 1.00
 Percent Moisture: NA

CAS Number	Analyte	RL	Result
56-55-3	Benzo(a)anthracene	67	< 67 U
218-01-9	Chrysene	67	< 67 U
50-32-8	Benzo(a)pyrene	67	< 67 U
193-39-5	Indeno(1,2,3-cd)pyrene	67	< 67 U
53-70-3	Dibenz(a,h)anthracene	67	< 67 U
TOTBFA	Total Benzofluoranthenes	67	< 67 U

Reported in µg/kg (ppb)

Semivolatile Surrogate Recovery

d14-p-Terphenyl	91.6%
2-Fluorobiphenyl	83.2%

SW8270 PNA SURROGATE RECOVERY SUMMARY



Matrix: Soil

QC Report No: XH06-Landau Associates, Inc.
 Project: Kaiser IA
 118033.100.104

<u>Client ID</u>	<u>TER</u>	<u>FBP</u>	<u>TOT OUT</u>
MB-092713	91.6%	83.2%	0
LCS-092713	91.6%	83.2%	0
LCSD-092713	89.2%	82.0%	0
SPL-23-20130927	72.0%	66.0%	0
SPL-24-20130927	82.0%	79.2%	0
SPL-24-20130927 DL	88.9%	83.0%	0
SPL-25-20130927	61.6%	63.2%	0

LCS/MB LIMITS QC LIMITS

(TER) = d14-p-Terphenyl (30-160) (30-160)
 (FBP) = 2-Fluorobiphenyl (30-160) (30-160)

Prep Method: SW3546
 Log Number Range: 13-20993 to 13-20995

ORGANICS ANALYSIS DATA SHEET

PNAs by SW8270D GC/MS

Page 1 of 1

Sample ID: LCS-092713

LCS/LCSD

Lab Sample ID: LCS-092713

LIMS ID: 13-20993

Matrix: Soil

Data Release Authorized: *[Signature]*

Reported: 09/30/13

QC Report No: XH06-Landau Associates, Inc.

Project: Kaiser IA

118033.100.104

Date Sampled: NA

Date Received: 09/27/13

Date Extracted LCS/LCSD: 09/27/13

Sample Amount LCS: 7.50 g-dry-wt

LCSD: 7.50 g-dry-wt

Date Analyzed LCS: 09/27/13 20:44

Final Extract Volume LCS: 0.50 mL

LCSD: 09/27/13 21:12

LCSD: 0.50 mL

Instrument/Analyst LCS: NT8/JZ

Dilution Factor LCS: 1.00

LCSD: NT8/JZ

LCSD: 1.00

GPC Cleanup: No

Alumina Cleanup: No

Silica Gel Cleanup: No

Analyte	LCS	Spike Added-LCS	LCS Recovery	LCSD	Spike Added-LCSD	LCSD Recovery	RPD
Benzo(a)anthracene	1220	1670	73.1%	1260	1670	75.4%	3.2%
Chrysene	1290	1670	77.2%	1320	1670	79.0%	2.3%
Benzo(a)pyrene	1190	1670	71.3%	1240	1670	74.3%	4.1%
Indeno(1,2,3-cd)pyrene	1370	1670	82.0%	1400	1670	83.8%	2.2%
Dibenz(a,h)anthracene	1430	1670	85.6%	1470	1670	88.0%	2.8%
Total Benzofluoranthenes	2850	3330	85.6%	2930	3330	88.0%	2.8%

Semivolatile Surrogate Recovery

	LCS	LCSD
d14-p-Terphenyl	91.6%	89.2%
2-Fluorobiphenyl	83.2%	82.0%

Results reported in µg/kg

RPD calculated using sample concentrations per SW846.



Analytical Resources, Incorporated
Analytical Chemists and Consultants

October 8, 2013

Dave Pischer
Landau Associates, Inc.
950 Pacific Ave # 515
Tacoma, WA 98402

RE: Project: Kaiser IA
ARI Job No: XI63

Dear Dave:

Please find enclosed the original Chain-of-Custody (COC) record, sample receipt documentation, and the analytical results for the samples from the projects referenced above. Analytical Resources, Inc. (ARI) accepted two soil samples on October 4, 2013 in good condition. For further details regarding sample receipt, please refer to the enclosed Cooler Receipt Form.

The samples were analyzed for cPAHs, as requested on the COC.

No analytical complications were noted.

An electronic copy of this report and all associated raw data will remain on file with ARI. If you have any questions or require additional information, please feel free to contact me at your convenience.

Sincerely,
ANALYTICAL RESOURCES, INC.

A handwritten signature in black ink, appearing to read "Kelly Bottem".

Kelly Bottem
Client Services Manager
206/695-6211
kellyb@arilabs.com

Enclosures

1 of 9

Seattle/Edmonds (425) 778-0907

Tacoma (253) 926-2493

Spokane (509) 327-9737

Portland (503) 542-1080



Chain-of-Custody Record

Page 1 of 1

Date 10/4/2013

Page 1 of 1

Project Name Kaiser IA Project No. 118033.100.104

Project Location/Event Kaiser, Port of Tacoma

Sampler's Name DAR

Project Contact DAVE FISCHER

Send Results To Jess Stone, Sierra Mott, Anne Halverson, Bill Evans, Dave Fischer

Testing Parameters

Turnaround Time

Standard

Accelerated

1-2 Day TAT

Observations/Comments

Allow water samples to settle, collect aliquot from clear portion

NWTPH-Dx - run acid wash/silica gel cleanup

run samples standardized to _____ product

Analyze for EPH if no specific product identified

VOC/BTEX/VPH (soil):

non-preserved

preserved w/methanol

preserved w/sodium bisulfate

Freeze upon receipt

Dissolved metal water samples field filtered

Other _____

Special Shipment/Handling or Storage Requirements Ice

Method of Shipment

Delivered by LA1

Received by

Signature _____

Printed Name David Rupert

Company Landau Assoc. Inc

Date 10/4/2013 Time 14:22

Relinquished by

Signature _____

Printed Name Kenneth

Company _____

Date 10/4/13 Time 16:34

Received by

Signature _____

Printed Name Tony Street

Company _____

Date 10-4-13 Time 1634

CPAH 8270



Cooler Receipt Form

ARI Client: LAI

Project Name: Kaiser IA

COC No(s): _____ NA

Delivered by: Fed-Ex UPS Courier Hand Delivered Other: _____

Assigned ARI Job No: XI63

Tracking No: _____ NA

Preliminary Examination Phase:

Were intact, properly signed and dated custody seals attached to the outside of to cooler? YES NO

Were custody papers included with the cooler? YES NO

Were custody papers properly filled out (ink, signed, etc.) YES NO

Temperature of Cooler(s) (°C) (recommended 2 0-6.0 °C for chemistry)
Time: 1634

13 _____
Temp Gun ID#: 9287795 2

If cooler temperature is out of compliance fill out form 00070F

Cooler Accepted by: TS Date: 10-11-13 Time: 1634

Complete custody forms and attach all shipping documents

Log-In Phase:

Was a temperature blank included in the cooler? YES NO

What kind of packing material was used? ... Bubble Wrap Wet Ice Gel Packs Baggies Foam Block Paper Other: _____

Was sufficient ice used (if appropriate)? NA YES NO

Were all bottles sealed in individual plastic bags? YES NO

Did all bottles arrive in good condition (unbroken)? YES NO

Were all bottle labels complete and legible? YES NO

Did the number of containers listed on COC match with the number of containers received? YES NO

Did all bottle labels and tags agree with custody papers? YES NO

Were all bottles used correct for the requested analyses? YES NO

Do any of the analyses (bottles) require preservation? (attach preservation sheet, excluding VOCs). NA YES NO

Were all VOC vials free of air bubbles? NA YES NO

Was sufficient amount of sample sent in each bottle? YES NO

Date VOC Trip Blank was made at ARI... .. NA

Was Sample Split by ARI NA YES Date/Time: _____ Equipment: _____ Split by: _____

Samples Logged by TS Date: 10-11-13 Time: 1643

**** Notify Project Manager of discrepancies or concerns ****

Sample ID on Bottle	Sample ID on COC	Sample ID on Bottle	Sample ID on COC

Additional Notes, Discrepancies, & Resolutions:

By: _____ Date: _____

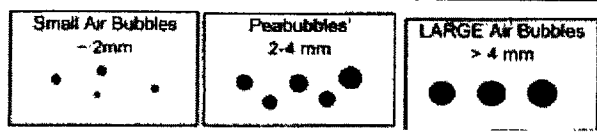

Small → "sm" (< 2 mm)
Peabubbles → "pb" (2 to < 4 mm)
Large → "lg" (4 to < 6 mm)
Headspace → "hs" (> 6 mm)

Sample ID Cross Reference Report



ARI Job No: XI63
Client: Landau Associates, Inc.
Project Event: 118033.100.104
Project Name: Kaiser IA

Sample ID	ARI Lab ID	ARI LIMS ID	Matrix	Sample Date/Time	VTSR
1. SPL-14-20131004	XI63A	13-21579	Soil	10/04/13 12:50	10/04/13 16:34
2. SPL-24-20131004	XI63B	13-21580	Soil	10/04/13 13:08	10/04/13 16:34

ORGANICS ANALYSIS DATA SHEET

PNAs by SW8270D GC/MS

Page 1 of 1

**Sample ID: SPL-14-20131004
SAMPLE**

Lab Sample ID: XI63A

LIMS ID: 13-21579

Matrix: Soil

Data Release Authorized: 

Reported: 10/08/13

QC Report No: XI63-Landau Associates, Inc.

Project: Kaiser IA

118033.100.104

Date Sampled: 10/04/13

Date Received: 10/04/13

Date Extracted: 10/07/13

Date Analyzed: 10/07/13 17:35

Instrument/Analyst: NT6/JZ

GPC Cleanup: No

Alumina: No

Silica Gel: No

Sample Amount: 7.52 g-dry-wt

Final Extract Volume: 0.5 mL

Dilution Factor: 1.00

Percent Moisture: 46.4%

CAS Number	Analyte	RL	Result
56-55-3	Benzo(a)anthracene	66	< 66 U
218-01-9	Chrysene	66	< 66 U
50-32-8	Benzo(a)pyrene	66	< 66 U
193-39-5	Indeno(1,2,3-cd)pyrene	66	< 66 U
53-70-3	Dibenz(a,h)anthracene	66	< 66 U
TOTBFA	Total Benzofluoranthenes	66	< 66 U

Reported in µg/kg (ppb)

Semivolatile Surrogate Recovery

d14-p-Terphenyl	56.0%
2-Fluorobiphenyl	57.6%

ORGANICS ANALYSIS DATA SHEET

PNAs by SW8270D GC/MS

Page 1 of 1

Sample ID: SPL-24-20131004

SAMPLE

Lab Sample ID: XI63B

LIMS ID: 13-21580

Matrix: Soil

Data Release Authorized: 

Reported: 10/08/13

QC Report No: XI63-Landau Associates, Inc.

Project: Kaiser IA

118033.100.104

Date Sampled: 10/04/13

Date Received: 10/04/13

Date Extracted: 10/07/13

Date Analyzed: 10/07/13 18:09

Instrument/Analyst: NT6/JZ

GPC Cleanup: No

Alumina: No

Silica Gel: No

Sample Amount: 8.00 g-dry-wt

Final Extract Volume: 0.5 mL

Dilution Factor: 1.00

Percent Moisture: 27.9%

CAS Number	Analyte	RL	Result
56-55-3	Benzo(a)anthracene	62	< 62 U
218-01-9	Chrysene	62	< 62 U
50-32-8	Benzo(a)pyrene	62	< 62 U
193-39-5	Indeno(1,2,3-cd)pyrene	62	< 62 U
53-70-3	Dibenz(a,h)anthracene	62	< 62 U
TOTBFA	Total Benzofluoranthenes	62	< 62 U

Reported in µg/kg (ppb)

Semivolatile Surrogate Recovery

d14-p-Terphenyl	61.6%
2-Fluorobiphenyl	64.4%

ORGANICS ANALYSIS DATA SHEET

PNAs by SW8270D GC/MS

Page 1 of 1

Sample ID: MB-100713

METHOD BLANK

Lab Sample ID: MB-100713

LIMS ID: 13-21579

Matrix: Soil

Data Release Authorized: 

Reported: 10/08/13

QC Report No: XI63-Landau Associates, Inc.

Project: Kaiser IA

118033.100.104

Date Sampled: NA

Date Received: NA

Date Extracted: 10/07/13

Date Analyzed: 10/07/13 15:53

Instrument/Analyst: NT6/JZ

GPC Cleanup: No

Alumina: No

Silica Gel: No

Sample Amount: 7.50 g-dry-wt

Final Extract Volume: 0.5 mL

Dilution Factor: 1.00

Percent Moisture: NA

CAS Number	Analyte	RL	Result
56-55-3	Benzo(a)anthracene	67	< 67 U
218-01-9	Chrysene	67	< 67 U
50-32-8	Benzo(a)pyrene	67	< 67 U
193-39-5	Indeno(1,2,3-cd)pyrene	67	< 67 U
53-70-3	Dibenz(a,h)anthracene	67	< 67 U
TOTBFA	Total Benzofluoranthenes	67	< 67 U

Reported in µg/kg (ppb)

Semivolatile Surrogate Recovery

d14-p-Terphenyl	76.4%
2-Fluorobiphenyl	71.6%

SW8270 PNA SURROGATE RECOVERY SUMMARY



Matrix: Soil

QC Report No: XI63-Landau Associates, Inc.
Project: Kaiser IA
118033.100.104

<u>Client ID</u>	<u>TER</u>	<u>FBP</u>	<u>TOT OUT</u>
MB-100713	76.4%	71.6%	0
LCS-100713	78.8%	66.8%	0
LCSD-100713	81.2%	67.6%	0
SPL-14-20131004	56.0%	57.6%	0
SPL-24-20131004	61.6%	64.4%	0

LCS/MB LIMITS QC LIMITS

(TER) = d14-p-Terphenyl (30-160) (30-160)
(FBP) = 2-Fluorobiphenyl (30-160) (30-160)

Prep Method: SW3546
Log Number Range: 13-21579 to 13-21580

ORGANICS ANALYSIS DATA SHEET

PNAs by SW8270D GC/MS

Page 1 of 1

Sample ID: LCS-100713

LCS/LCSD

Lab Sample ID: LCS-100713

LIMS ID: 13-21579

Matrix: Soil

Data Release Authorized: 

Reported: 10/08/13

QC Report No: XI63-Landau Associates, Inc.

Project: Kaiser IA

118033.100.104

Date Sampled: NA

Date Received: 10/04/13

Date Extracted LCS/LCSD: 10/07/13

Sample Amount LCS: 7.50 g-dry-wt

LCSD: 7.50 g-dry-wt

Date Analyzed LCS: 10/07/13 16:27

Final Extract Volume LCS: 0.50 mL

LCSD: 10/07/13 17:01

LCSD: 0.50 mL

Instrument/Analyst LCS: NT6/JZ

Dilution Factor LCS: 1.00

LCSD: NT6/JZ

LCSD: 1.00

GPC Cleanup: No

Alumina Cleanup: No

Silica Gel Cleanup: No

Analyte	Spike		LCS		Spike		LCSD	
	LCS	Added-LCS	Recovery	LCS	Added-LCSD	Recovery	RPD	
Benzo(a)anthracene	1320	1670	79.0%	1420	1670	85.0%	7.3%	
Chrysene	1350	1670	80.8%	1420	1670	85.0%	5.1%	
Benzo(a)pyrene	1360	1670	81.4%	1450	1670	86.8%	6.4%	
Indeno(1,2,3-cd)pyrene	1420	1670	85.0%	1530	1670	91.6%	7.5%	
Dibenz(a,h)anthracene	1460	1670	87.4%	1540	1670	92.2%	5.3%	
Total Benzofluoranthenes	2690	3330	80.8%	2850	3330	85.6%	5.8%	

Semivolatile Surrogate Recovery

	LCS	LCSD
d14-p-Terphenyl	78.8%	81.2%
2-Fluorobiphenyl	66.8%	67.6%

Results reported in µg/kg

RPD calculated using sample concentrations per SW846.



Analytical Resources, Incorporated
Analytical Chemists and Consultants

October 9, 2013

Dave Fischer
Landau Associates, Inc.
950 Pacific Ave # 515
Tacoma, WA 98402

RE: Project: Kaiser IA
ARI Job No: XI68

Dear Dave:

Please find enclosed the original Chain-of-Custody (COC) record, sample receipt documentation, and the analytical results for the samples from the projects referenced above. Analytical Resources, Inc. (ARI) accepted three soil samples on October 7, 2013 in good condition. For further details regarding sample receipt, please refer to the enclosed Cooler Receipt Form.

The samples were analyzed for cPAHs, as requested on the COC.

No analytical complications were noted.

An electronic copy of this report and all associated raw data will remain on file with ARI. If you have any questions or require additional information, please feel free to contact me at your convenience.

Sincerely,
ANALYTICAL RESOURCES, INC.

A handwritten signature in black ink, appearing to read "Kelly Bottem".

Kelly Bottem
Client Services Manager
206/695-6211
kellyb@arilabs.com

Enclosures



XI68

Chain-of-Custody Record

Project Name Kaiser IA Project No. 118033.100.104
 Project Location/Event Kaiser, Port of Tacoma
 Sampler's Name DAR
 Project Contact DAVE FISCHER
 Send Results To ANN HALVESEN, BILL EVANS, DAVE FISCHER

Sample I.D.	Date	Time	Matrix	No. of Containers	Testing Parameters	Observations/Comments	Turnaround Time
SPL-7-20131005	10/5/13	1120	Soil	1		X Allow water samples to settle, collect aliquot from clear portion	<input type="checkbox"/> Standard <input type="checkbox"/> Accelerated <input checked="" type="checkbox"/> 1-2 DAY TAT
SPL-26-20131005	10/5/13	1305	Soil	1			
SPL-BlackGneiss-20131007	10/7/13	1000	SOIL	1		X NWTPH-Dx - run acid wash/silica gel cleanup	
						run samples standardized to product	
						Analyze for EPH if no specific product identified	
						VOC/BTEX/VPH (soil):	
						non-preserved	
						preserved w/methanol	
						preserved w/sodium bisulfate	
						Freeze upon receipt	
						Dissolved metal water samples field filtered	
						Other	

Special Shipment/Handling or Storage Requirements Ice Method of Shipment Carrier

Received by	Relinquished by	Received by
Signature <u>[Signature]</u> Printed Name <u>R. G. Weber</u> Company <u>API</u> Date <u>10/7/13</u> Time <u>1225</u>	Signature _____ Printed Name _____ Company _____ Date _____ Time _____	Signature _____ Printed Name _____ Company _____ Date _____ Time _____

Sample ID Cross Reference Report



ARI Job No: XI68
Client: Landau Associates, Inc.
Project Event: 118033.100.104
Project Name: Kaiser IA

Sample ID	ARI Lab ID	ARI LIMS ID	Matrix	Sample Date/Time	VTSR
1. SPL-7-20131005	XI68A	13-21602	Soil	10/05/13 11:20	10/07/13 12:25
2. SPL-26-20131005	XI68B	13-21603	Soil	10/05/13 13:05	10/07/13 12:25
3. SPL-BLACKGRAVELSEAM-2013XI68C		13-21604	Soil	10/07/13 10:00	10/07/13 12:25



Cooler Receipt Form

ARI Client: Landau

Project Name: Kaiser IA

COC No(s): _____ (NA)

Delivered by: Fed-Ex UPS Courier Hand Delivered Other: _____

Assigned ARI Job No: XIICB

Tracking No: _____ (NA)

Preliminary Examination Phase:

Were intact, properly signed and dated custody seals attached to the outside of to cooler? YES NO

Were custody papers included with the cooler? YES NO

Were custody papers properly filled out (ink, signed, etc.) YES NO

Temperature of Cooler(s) (°C) (recommended 2.0-6.0 °C for chemistry)

Time: 1326

If cooler temperature is out of compliance fill out form 00070F

Temp Gun ID#: 90877952 ^{6.9}

Cooler Accepted by: _____ Date: 10/7/13 Time: 1225

Complete custody forms and attach all shipping documents

Log-In Phase:

Was a temperature blank included in the cooler? YES NO

What kind of packing material was used? ... Bubble Wrap Wet Ice Gel Packs Baggies Foam Block Paper Other: _____

Was sufficient ice used (if appropriate)? NA YES NO

Were all bottles sealed in individual plastic bags? YES NO

Did all bottles arrive in good condition (unbroken)? YES NO

Were all bottle labels complete and legible? YES NO

Did the number of containers listed on COC match with the number of containers received? YES NO

Did all bottle labels and tags agree with custody papers? YES NO

Were all bottles used correct for the requested analyses? YES NO

Do any of the analyses (bottles) require preservation? (attach preservation sheet, excluding VOCs) .. NA YES NO

Were all VOC vials free of air bubbles? NA YES NO

Was sufficient amount of sample sent in each bottle? YES NO

Date VOC Trip Blank was made at ARI: NA

Was Sample Split by ARI: YES Date/Time: _____ Equipment: _____ Split by: _____

Samples Logged by: AV Date: 10/7/13 Time: 1336

**** Notify Project Manager of discrepancies or concerns ****

Sample ID on Bottle	Sample ID on COC	Sample ID on Bottle	Sample ID on COC

Additional Notes, Discrepancies, & Resolutions:

By: _____ Date: _____

			Small → "sm" (< 2 mm)
			Peabubbles → "pb" (2 to < 4 mm)
			Large → "lg" (4 to < 6 mm)
			Headspace → "hs" (> 6 mm)



Cooler Temperature Compliance Form

XI68

Cooler#: <u>1</u>		Temperature(°C): <u>6.9</u>	
Sample ID	Bottle Count	Bottle Type	
Samples received above 10°C.			

Cooler#: _____		Temperature(°C): _____	
Sample ID	Bottle Count	Bottle Type	

Cooler#: _____		Temperature(°C): _____	
Sample ID	Bottle Count	Bottle Type	

Cooler#: _____		Temperature(°C): _____	
Sample ID	Bottle Count	Bottle Type	

Completed by: AV Date: 10/7/13 Time: 1330

ORGANICS ANALYSIS DATA SHEET

PNAs by SW8270D GC/MS

Page 1 of 1



Sample ID: SPL-7-20131005

SAMPLE

Lab Sample ID: XI68A

LIMS ID: 13-21602

Matrix: Soil

Data Release Authorized: *AS*

Reported: 10/09/13

QC Report No: XI68-Landau Associates, Inc.

Project: Kaiser IA

118033.100.104

Date Sampled: 10/05/13

Date Received: 10/07/13

Date Extracted: 10/08/13

Date Analyzed: 10/08/13 17:25

Instrument/Analyst: NT6/JZ

GPC Cleanup: No

Alumina: No

Silica Gel: No

Sample Amount: 7.82 g-dry-wt

Final Extract Volume: 0.5 mL

Dilution Factor: 1.00

Percent Moisture: 29.2%

CAS Number	Analyte	RL	Result
56-55-3	Benzo(a)anthracene	64	< 64 U
218-01-9	Chrysene	64	< 64 U
50-32-8	Benzo(a)pyrene	64	< 64 U
193-39-5	Indeno(1,2,3-cd)pyrene	64	< 64 U
53-70-3	Dibenz(a,h)anthracene	64	< 64 U
TOTBFA	Total Benzofluoranthenes	64	< 64 U

Reported in µg/kg (ppb)

Semivolatile Surrogate Recovery

d14-p-Terphenyl	60.8%
2-Fluorobiphenyl	63.2%

ORGANICS ANALYSIS DATA SHEET

PNAs by SW8270D GC/MS

Page 1 of 1

Sample ID: SPL-26-20131005

SAMPLE

Lab Sample ID: XI68B

LIMS ID: 13-21603

Matrix: Soil

Data Release Authorized: *AS*

Reported: 10/09/13

QC Report No: XI68-Landau Associates, Inc.

Project: Kaiser IA

118033.100.104

Date Sampled: 10/05/13

Date Received: 10/07/13

Date Extracted: 10/08/13

Date Analyzed: 10/08/13 18:32

Instrument/Analyst: NT6/JZ

GPC Cleanup: No

Alumina: No

Silica Gel: No

Sample Amount: 7.58 g-dry-wt

Final Extract Volume: 0.5 mL

Dilution Factor: 1.00

Percent Moisture: 24.4%

CAS Number	Analyte	RL	Result
56-55-3	Benzo(a)anthracene	66	< 66 U
218-01-9	Chrysene	66	< 66 U
50-32-8	Benzo(a)pyrene	66	< 66 U
193-39-5	Indeno(1,2,3-cd)pyrene	66	< 66 U
53-70-3	Dibenz(a,h)anthracene	66	< 66 U
TOTBFA	Total Benzofluoranthenes	66	< 66 U

Reported in µg/kg (ppb)

Semivolatile Surrogate Recovery

d14-p-Terphenyl	68.8%
2-Fluorobiphenyl	60.0%

ORGANICS ANALYSIS DATA SHEET

PNA's by SW8270D GC/MS

Page 1 of 1



Sample ID: SPL-BLACKGRAVELSEAM-20131007
DILUTION

Lab Sample ID: XI68C

LIMS ID: 13-21604

Matrix: Soil

Data Release Authorized: *[Signature]*

Reported: 10/09/13

QC Report No: XI68-Landau Associates, Inc.

Project: Kaiser IA

118033.100.104

Date Sampled: 10/07/13

Date Received: 10/07/13

Date Extracted: 10/08/13

Date Analyzed: 10/08/13 17:58

Instrument/Analyst: NT6/JZ

GPC Cleanup: No

Alumina: No

Silica Gel: No

Sample Amount: 7.95 g-dry-wt

Final Extract Volume: 0.5 mL

Dilution Factor: 3.00

Percent Moisture: 12.0%

CAS Number	Analyte	RL	Result
56-55-3	Benzo (a) anthracene	190	6,200
218-01-9	Chrysene	190	11,000
50-32-8	Benzo (a) pyrene	190	4,500
193-39-5	Indeno (1,2,3-cd) pyrene	190	3,900
53-70-3	Dibenz (a,h) anthracene	190	2,000
TOTBFA	Total Benzofluoranthenes	190	12,000

Reported in µg/kg (ppb)

Semivolatile Surrogate Recovery

d14-p-Terphenyl	83.2%
2-Fluorobiphenyl	83.3%

ORGANICS ANALYSIS DATA SHEET

PNA's by SW8270D GC/MS

Page 1 of 1



Sample ID: SPL-BLACKGRAVELSEAM-20131007
SAMPLE

Lab Sample ID: XI68C

LIMS ID: 13-21604

Matrix: Soil

Data Release Authorized: *[Signature]*

Reported: 10/09/13

QC Report No: XI68-Landau Associates, Inc.

Project: Kaiser IA

118033.100.104

Date Sampled: 10/07/13

Date Received: 10/07/13

Date Extracted: 10/08/13

Date Analyzed: 10/08/13 19:06

Instrument/Analyst: NT6/JZ

GPC Cleanup: No

Alumina: No

Silica Gel: No

Sample Amount: 7.95 g-dry-wt

Final Extract Volume: 0.5 mL

Dilution Factor: 1.00

Percent Moisture: 12.0%

CAS Number	Analyte	RL	Result
56-55-3	Benzo (a) anthracene	63	5,300 E
218-01-9	Chrysene	63	8,900 ES
50-32-8	Benzo (a) pyrene	63	3,800
193-39-5	Indeno (1,2,3-cd) pyrene	63	2,600
53-70-3	Dibenz (a,h) anthracene	63	1,400
TOTBFA	Total Benzofluoranthenes	63	9,400

Reported in µg/kg (ppb)

Semivolatile Surrogate Recovery

d14-p-Terphenyl	71.2%
2-Fluorobiphenyl	70.4%

ORGANICS ANALYSIS DATA SHEET

PNA's by SW8270D GC/MS

Page 1 of 1



Sample ID: MB-100813

METHOD BLANK

Lab Sample ID: MB-100813

LIMS ID: 13-21602

Matrix: Soil

Data Release Authorized: *AS*

Reported: 10/09/13

QC Report No: XI68-Landau Associates, Inc.

Project: Kaiser IA

118033.100.104

Date Sampled: NA

Date Received: NA

Date Extracted: 10/08/13

Date Analyzed: 10/08/13 15:43

Instrument/Analyst: NT6/JZ

GPC Cleanup: No

Alumina: No

Silica Gel: No

Sample Amount: 7.50 g-dry-wt

Final Extract Volume: 0.5 mL

Dilution Factor: 1.00

Percent Moisture: NA

CAS Number	Analyte	RL	Result
56-55-3	Benzo(a)anthracene	67	< 67 U
218-01-9	Chrysene	67	< 67 U
50-32-8	Benzo(a)pyrene	67	< 67 U
193-39-5	Indeno(1,2,3-cd)pyrene	67	< 67 U
53-70-3	Dibenz(a,h)anthracene	67	< 67 U
TOTBFA	Total Benzofluoranthenes	67	< 67 U

Reported in µg/kg (ppb)

Semivolatile Surrogate Recovery

d14-p-Terphenyl	85.6%
2-Fluorobiphenyl	70.8%

SW8270 PNA SURROGATE RECOVERY SUMMARY



Matrix: Soil

QC Report No: XI68-Landau Associates, Inc.
 Project: Kaiser IA
 118033.100.104

Client ID	TER	FBP	TOT OUT
MB-100813	85.6%	70.8%	0
LCS-100813	84.4%	66.8%	0
LCSD-100813	84.4%	67.6%	0
SPL-7-20131005	60.8%	63.2%	0
SPL-26-20131005	68.8%	60.0%	0
SPL-BLACKGRAVELSEAM-	71.2%	70.4%	0
SPL-BLACKGRAVELSEAM-DL	83.2%	83.3%	0

LCS/MB LIMITS QC LIMITS

(TER) = d14-p-Terphenyl (30-160) (30-160)
 (FBP) = 2-Fluorobiphenyl (30-160) (30-160)

Prep Method: SW3546
 Log Number Range: 13-21602 to 13-21604

ORGANICS ANALYSIS DATA SHEET

PNAs by SW8270D GC/MS

Page 1 of 1



Sample ID: LCS-100813

LCS/LCSD

Lab Sample ID: LCS-100813

LIMS ID: 13-21602

Matrix: Soil

Data Release Authorized: *AS*

Reported: 10/09/13

QC Report No: XI68-Landau Associates, Inc.

Project: Kaiser IA

118033.100.104

Date Sampled: NA

Date Received: 10/07/13

Date Extracted LCS/LCSD: 10/08/13

Sample Amount LCS: 7.50 g-dry-wt

LCSD: 7.50 g-dry-wt

Date Analyzed LCS: 10/08/13 16:17

Final Extract Volume LCS: 0.50 mL

LCSD: 10/08/13 16:51

LCSD: 0.50 mL

Instrument/Analyst LCS: NT6/JZ

Dilution Factor LCS: 1.00

LCSD: NT6/JZ

LCSD: 1.00

GPC Cleanup: No

Alumina Cleanup: No

Silica Gel Cleanup: No

Analyte	Spike		LCS	LCS	Spike		LCSD	RPD
	LCS	Added-LCS	Recovery		Added-LCSD	Recovery		
Benzo(a)anthracene	1340	1670	80.2%	1410	1670	84.4%	5.1%	
Chrysene	1330	1670	79.6%	1380	1670	82.6%	3.7%	
Benzo(a)pyrene	1340	1670	80.2%	1430	1670	85.6%	6.5%	
Indeno(1,2,3-cd)pyrene	1400	1670	83.8%	1470	1670	88.0%	4.9%	
Dibenz(a,h)anthracene	1390	1670	83.2%	1490	1670	89.2%	6.9%	
Total Benzofluoranthenes	2740	3330	82.3%	2910	3330	87.4%	6.0%	

Semivolatile Surrogate Recovery

	LCS	LCSD
d14-p-Terphenyl	84.4%	84.4%
2-Fluorobiphenyl	66.8%	67.6%

Results reported in µg/kg

RPD calculated using sample concentrations per SW846.



Analytical Resources, Incorporated
Analytical Chemists and Consultants

October 9, 2013

Dave Pischer
Landau Associates, Inc.
950 Pacific Ave # 515
Tacoma, WA 98402

RE: Project: Kaiser IA
ARI Job No: XJ15

Dear Dave:

Please find enclosed the original Chain-of-Custody (COC) record, sample receipt documentation, and the analytical results for the samples from the projects referenced above. Analytical Resources, Inc. (ARI) accepted two soil samples on October 9, 2013 in good condition. For further details regarding sample receipt, please refer to the enclosed Cooler Receipt Form.

The samples were analyzed for cPAHs, as requested on the COC.

No analytical complications were noted.

An electronic copy of this report and all associated raw data will remain on file with ARI. If you have any questions or require additional information, please feel free to contact me at your convenience.

Sincerely,
ANALYTICAL RESOURCES, INC.

A handwritten signature in black ink, appearing to read "Kelly Bottem".

Kelly Bottem
Client Services Manager
206/695-6211
kellyb@arilabs.com

Enclosures

Chain-of-Custody Record

Project Name <u>Kaiser IA</u> Project No. <u>118033.100.101</u> Project Location/Event <u>Kaiser Part of Tacoma</u> Sampler's Name <u>DAM</u> Project Contact <u>Dave Pischer</u> Send Results To <u>Anne Halverson, Jessica Stone, Bill Evans, Dave Pischer</u>		Testing Parameters <u>CPAs 8270D</u>	Turnaround Time <input type="checkbox"/> Standard <input type="checkbox"/> Accelerated <input checked="" type="checkbox"/> <u>12 day TAT</u>		
Sample I.D. <u>SPL-27-20B1009</u> <u>SPL-28-20B1009</u>	Date <u>10/1/13</u> <u>10/1/13</u>	Time <u>1100</u> <u>1120</u>	Matrix <u>Soil</u> <u>Soil</u>	No. of Containers <u>1</u> <u>1</u>	Observations/Comments <input checked="" type="checkbox"/> Allow water samples to settle, collect aliquot from clear portion <input checked="" type="checkbox"/> NWTPH-Dx - run acid wash/silica gel cleanup ___ run samples standardized to _____ product ___ Analyze for EPH if no specific product identified VOC/BTEX/VPH (soil): ___ non-preserved ___ preserved w/methanol ___ preserved w/sodium bisulfate ___ Freeze upon receipt ___ Dissolved metal water samples field filtered Other _____ _____ _____
Special Shipment/Handling or Storage Requirements <u>Ice</u> Method of Shipment <u>Carries</u>					
Relinquished by Signature <u>[Signature]</u> Printed Name <u>Dan Mulkenius</u> Company <u>LA</u> Date <u>10/1/13</u> Time <u>1440</u>	Received by Signature <u>[Signature]</u> Printed Name <u>Rick Hagan</u> Company <u>DRY</u> Date <u>10/9/13</u> Time <u>1440</u>	Relinquished by Signature _____ Printed Name _____ Company _____ Date _____ Time _____	Received by Signature _____ Printed Name _____ Company _____ Date _____ Time _____		



Cooler Receipt Form

ARI Client: LAI

Project Name: Kaiser IA

COC No(s): _____ NA

Delivered by: Fed-Ex UPS Courier Hand Delivered Other: _____

Assigned ARI Job No: X5 15

Tracking No: _____ NA

Preliminary Examination Phase:

Were intact, properly signed and dated custody seals attached to the outside of to cooler? YES NO

Were custody papers included with the cooler? ... YES NO

Were custody papers properly filled out (ink, signed, etc) ... YES NO

Temperature of Cooler(s) (°C) (recommended 2.0-6.0 °C for chemistry)
Time: 15:15

Temp Gun ID#: 90077952
10.2

If cooler temperature is out of compliance fill out form 00070F

Cooler Accepted by: _____ Date: 10/9/13 Time: 1440

Complete custody forms and attach all shipping documents

Log-In Phase:

Was a temperature blank included in the cooler? ... YES NO

What kind of packing material was used? ... Bubble Wrap Wet Ice Gel Packs Baggies Foam Block Paper Other: _____

Was sufficient ice used (if appropriate)? ... NA YES NO

Were all bottles sealed in individual plastic bags? ... YES NO

Did all bottles arrive in good condition (unbroken)? ... YES NO

Were all bottle labels complete and legible? ... YES NO

Did the number of containers listed on COC match with the number of containers received? ... YES NO

Did all bottle labels and tags agree with custody papers? ... YES NO

Were all bottles used correct for the requested analyses? ... YES NO

Do any of the analyses (bottles) require preservation? (attach preservation sheet, excluding VOCs) .. NA YES NO

Were all VOC vials free of air bubbles? ... NA YES NO

Was sufficient amount of sample sent in each bottle? ... YES NO

Date VOC Trip Blank was made at ARI: ... NA _____

Was Sample Split by ARI: NA YES Date/Time: _____ Equipment: _____ Split by: _____

Samples Logged by _____ Date: 10-9-13 Time: 1524

**** Notify Project Manager of discrepancies or concerns ****

Sample ID on Bottle	Sample ID on COC	Sample ID on Bottle	Sample ID on COC

Additional Notes, Discrepancies, & Resolutions:

By: _____ Date: _____

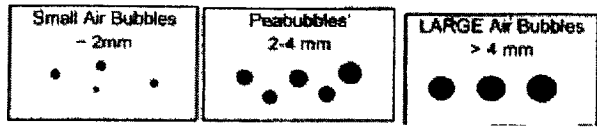

Small → "sm" (< 2 mm)
Peabubbles → "pb" (2 to < 4 mm)
Large → "lg" (4 to < 6 mm)
Headspace → "hs" (> 6 mm)

Sample ID Cross Reference Report



ARI Job No: XJ15
Client: Landau Associates, Inc.
Project Event: 118033.100.104
Project Name: Kaiser IA

Sample ID	ARI Lab ID	ARI LIMS ID	Matrix	Sample Date/Time	VTSR
1. SPL-27-20131009	XJ15A	13-21982	Soil	10/09/13 11:00	10/09/13 14:40
2. SPL-28-20131009	XJ15B	13-21983	Soil	10/09/13 11:20	10/09/13 14:40

ORGANICS ANALYSIS DATA SHEET

PNAs by SW8270D GC/MS

Page 1 of 1

Sample ID: SPL-27-20131009

SAMPLE

Lab Sample ID: XJ15A

LIMS ID: 13-21982

Matrix: Soil

Data Release Authorized: 

Reported: 10/10/13

QC Report No: XJ15-Landau Associates, Inc.

Project: Kaiser IA

118033.100.104

Date Sampled: 10/09/13

Date Received: 10/09/13

Date Extracted: 10/09/13

Date Analyzed: 10/10/13 11:01

Instrument/Analyst: NT6/JZ

GPC Cleanup: No

Alumina: No

Silica Gel: No

Sample Amount: 6.70 g-dry-wt

Final Extract Volume: 0.5 mL

Dilution Factor: 1.00

Percent Moisture: 48.6%

CAS Number	Analyte	RL	Result
56-55-3	Benzo(a)anthracene	75	< 75 U
218-01-9	Chrysene	75	< 75 U
50-32-8	Benzo(a)pyrene	75	< 75 U
193-39-5	Indeno(1,2,3-cd)pyrene	75	< 75 U
53-70-3	Dibenz(a,h)anthracene	75	< 75 U
TOTBFA	Total Benzofluoranthenes	75	< 75 U

Reported in µg/kg (ppb)

Semivolatile Surrogate Recovery

d14-p-Terphenyl	40.8%
2-Fluorobiphenyl	46.8%

ORGANICS ANALYSIS DATA SHEET

PNAs by SW8270D GC/MS

Page 1 of 1

**Sample ID: SPL-28-20131009
SAMPLE**

Lab Sample ID: XJ15B

LIMS ID: 13-21983

Matrix: Soil

Data Release Authorized: *[Signature]*

Reported: 10/10/13

QC Report No: XJ15-Landau Associates, Inc.

Project: Kaiser IA

118033.100.104

Date Sampled: 10/09/13

Date Received: 10/09/13

Date Extracted: 10/09/13

Date Analyzed: 10/10/13 11:35

Instrument/Analyst: NT6/JZ

GPC Cleanup: No

Alumina: No

Silica Gel: No

Sample Amount: 6.28 g-dry-wt

Final Extract Volume: 0.5 mL

Dilution Factor: 1.00

Percent Moisture: 52.1%

CAS Number	Analyte	RL	Result
56-55-3	Benzo(a)anthracene	80	< 80 U
218-01-9	Chrysene	80	< 80 U
50-32-8	Benzo(a)pyrene	80	< 80 U
193-39-5	Indeno(1,2,3-cd)pyrene	80	< 80 U
53-70-3	Dibenz(a,h)anthracene	80	< 80 U
TOTBFA	Total Benzofluoranthenes	80	< 80 U

Reported in µg/kg (ppb)

Semivolatile Surrogate Recovery

d14-p-Terphenyl	35.3%
2-Fluorobiphenyl	42.0%

ORGANICS ANALYSIS DATA SHEET

PNAs by SW8270D GC/MS

Page 1 of 1

Sample ID: MB-100913

METHOD BLANK

Lab Sample ID: MB-100913

LIMS ID: 13-21982

Matrix: Soil

Data Release Authorized: *AS*

Reported: 10/10/13

QC Report No: XJ15-Landau Associates, Inc.

Project: Kaiser IA

118033.100.104

Date Sampled: NA

Date Received: NA

Date Extracted: 10/09/13

Date Analyzed: 10/10/13 09:19

Instrument/Analyst: NT6/JZ

GPC Cleanup: No

Alumina: No

Silica Gel: No

Sample Amount: 7.50 g-dry-wt

Final Extract Volume: 0.5 mL

Dilution Factor: 1.00

Percent Moisture: NA

CAS Number	Analyte	RL	Result
56-55-3	Benzo(a)anthracene	67	< 67 U
218-01-9	Chrysene	67	< 67 U
50-32-8	Benzo(a)pyrene	67	< 67 U
193-39-5	Indeno(1,2,3-cd)pyrene	67	< 67 U
53-70-3	Dibenz(a,h)anthracene	67	< 67 U
TOTBFA	Total Benzofluoranthenes	67	< 67 U

Reported in µg/kg (ppb)

Semivolatile Surrogate Recovery

d14-p-Terphenyl	80.8%
2-Fluorobiphenyl	69.6%

SW8270 PNA SURROGATE RECOVERY SUMMARY



Matrix: Soil

QC Report No: XJ15-Landau Associates, Inc.
Project: Kaiser IA
118033.100.104

<u>Client ID</u>	<u>TER</u>	<u>FBP</u>	<u>TOT OUT</u>
MB-100913	80.8%	69.6%	0
LCS-100913	87.2%	74.0%	0
LCSD-100913	90.8%	74.8%	0
SPL-27-20131009	40.8%	46.8%	0
SPL-28-20131009	35.3%	42.0%	0

LCS/MB LIMITS QC LIMITS

(TER) = d14-p-Terphenyl (30-160) (30-160)
(FBP) = 2-Fluorobiphenyl (30-160) (30-160)

Prep Method: SW3546
Log Number Range: 13-21982 to 13-21983



ORGANICS ANALYSIS DATA SHEET

PNAs by SW8270D GC/MS

Page 1 of 1

Sample ID: LCS-100913

LCS/LCSD

Lab Sample ID: LCS-100913

LIMS ID: 13-21982

Matrix: Soil

Data Release Authorized: *[Signature]*

Reported: 10/10/13

QC Report No: XJ15-Landau Associates, Inc.

Project: Kaiser IA

118033.100.104

Date Sampled: NA

Date Received: 10/09/13

Date Extracted LCS/LCSD: 10/09/13

Sample Amount LCS: 7.50 g-dry-wt

LCSD: 7.50 g-dry-wt

Date Analyzed LCS: 10/10/13 09:53

Final Extract Volume LCS: 0.50 mL

LCSD: 10/10/13 10:27

LCSD: 0.50 mL

Instrument/Analyst LCS: NT6/JZ

Dilution Factor LCS: 1.00

LCSD: NT6/JZ

LCSD: 1.00

GPC Cleanup: No

Alumina Cleanup: No

Silica Gel Cleanup: No

Analyte	LCS	Spike Added-LCS	LCS Recovery	LCSD	Spike Added-LCSD	LCSD Recovery	RPD
Benzo(a)anthracene	1430	1670	85.6%	1510	1670	90.4%	5.4%
Chrysene	1390	1670	83.2%	1470	1670	88.0%	5.6%
Benzo(a)pyrene	1540	1670	92.2%	1660	1670	99.4%	7.5%
Indeno(1,2,3-cd)pyrene	1370	1670	82.0%	1450	1670	86.8%	5.7%
Dibenz(a,h)anthracene	1380	1670	82.6%	1470	1670	88.0%	6.3%
Total Benzofluoranthenes	2960	3330	88.9%	3220	3330	96.7%	8.4%

Semivolatile Surrogate Recovery

	LCS	LCSD
d14-p-Terphenyl	87.2%	90.8%
2-Fluorobiphenyl	74.0%	74.8%

Results reported in µg/kg

RPD calculated using sample concentrations per SW846.



Analytical Resources, Incorporated
Analytical Chemists and Consultants

October 14, 2013

Dave Pischer
Landau Associates, Inc.
950 Pacific Ave # 515
Tacoma, WA 98402

RE: Project: Kaiser IA
ARI Job No: XJ41

Dear Dave:

Please find enclosed the original Chain-of-Custody (COC) record, sample receipt documentation, and the analytical results for the samples from the projects referenced above. Analytical Resources, Inc. (ARI) accepted five soil samples on October 10, 2013 in good condition. For further details regarding sample receipt, please refer to the enclosed Cooler Receipt Form.

The samples were analyzed for cPAHs, as requested on the COC.

No analytical complications were noted.

An electronic copy of this report and all associated raw data will remain on file with ARI. If you have any questions or require additional information, please feel free to contact me at your convenience.

Sincerely,
ANALYTICAL RESOURCES, INC.

Kelly Bottem
Kelly Bottem
Client Services Manager
206/695-6211
kellyb@arilabs.com

Enclosures

1 of 15

- Seattle/Edmonds (425) 778-0907
- Tacoma (253) 926-2493
- Spokane (509) 327-9737
- Portland (503) 542-1080



XJ41

Date 10/10/13
Page 1 of 1

Chain-of-Custody Record

Project Name Kaiser IA Project No. 118033.100.104
 Project Location/Event Kaiser, Part of Tacoma
 Sampler's Name DAM
 Project Contact Dave Pischer
 Send Results To Anne Halverson, Jessica Stone, Bill Evans, Dave Pischer

Testing Parameters

Turnaround Time
 Standard
 Accelerated
 1-2 day TAT

Sample I.D.	Date	Time	Matrix	No. of Containers
SPL-29-20131010	10/10/13	930	SOIL	1
SPL-30-20131016	↓	940	↓	↓
SPL-31-20131010	↓	1000	↓	↓
SPL-32-20131010	↓	1230	↓	↓
SPL-33-20131010	↓	900	↓	↓

(PATHS)

Observations/Comments
 Allow water samples to settle, collect aliquot from clear portion
 NWTPH-Dx - run acid wash/silica gel cleanup
 ___ run samples standardized to ___ product
 ___ Analyze for EPH if no specific product identified
 VOC/BTEX/VPH (soil):
 ___ non-preserved
 ___ preserved w/methanol
 ___ preserved w/sodium bisulfate
 ___ Freeze upon receipt
 ___ Dissolved metal water samples field filtered
 Other _____

Special Shipment/Handling or Storage Requirements ON IC

Method of Shipment Carrier

Relinquished by
 Signature [Signature]
 Printed Name Don Mulkerns
 Company LA
 Date 10/10/13 Time 1322

Received by
 Signature [Signature]
 Printed Name Rich Halverson
 Company ARI
 Date 10/10/13 Time 1322

Relinquished by
 Signature _____
 Printed Name _____
 Company _____
 Date _____ Time _____

Received by
 Signature _____
 Printed Name _____
 Company _____
 Date _____ Time _____

XJ41 : 00002



Cooler Receipt Form

ARI Client: LAI

Project Name: Kaiser IA

COC No(s): _____ (NA)

Delivered by: Fed-Ex UPS Courier Hand Delivered Other: _____

Assigned ARI Job No: XJ41

Tracking No: _____ (NA)

Preliminary Examination Phase:

Were intact, properly signed and dated custody seals attached to the outside of to cooler? YES NO

Were custody papers included with the cooler? YES NO

Were custody papers properly filled out (ink, signed, etc.) YES NO

Temperature of Cooler(s) (°C) (recommended 2.0-6.0 °C for chemistry) 2.6

Time 14:45

If cooler temperature is out of compliance fill out form 00070F

Temp Gun ID#: 90877952

Cooler Accepted by: _____ Date: 10/10/13 Time: 1322

Complete custody forms and attach all shipping documents

Log-In Phase:

Was a temperature blank included in the cooler? YES NO

What kind of packing material was used? Bubble Wrap Wet Ice Gel Packs Baggies Foam Block Paper Other: _____

Was sufficient ice used (if appropriate)? NA YES NO

Were all bottles sealed in individual plastic bags? YES NO

Did all bottles arrive in good condition (unbroken)? YES NO

Were all bottle labels complete and legible? YES NO

Did the number of containers listed on COC match with the number of containers received? YES NO

Did all bottle labels and tags agree with custody papers? YES NO

Were all bottles used correct for the requested analyses? YES NO

Do any of the analyses (bottles) require preservation? (attach preservation sheet, excluding VOCs)... NA YES NO

Were all VOC vials free of air bubbles? NA YES NO

Was sufficient amount of sample sent in each bottle? YES NO

Date VOC Trip Blank was made at ARI: NA

Was Sample Split by ARI: NA YES Date/Time: _____ Equipment: _____ Split by: _____

Samples Logged by: AV Date: 10/10/13 Time: 1510

**** Notify Project Manager of discrepancies or concerns ****

Sample ID on Bottle	Sample ID on COC	Sample ID on Bottle	Sample ID on COC

Additional Notes, Discrepancies, & Resolutions:

By: _____ Date: _____

<p>Small Air Bubbles ~ 2mm</p>	<p>Peabubbles 2-4 mm</p>	<p>LARGE Air Bubbles > 4 mm</p>	Small → "sm" (< 2 mm)
			Peabubbles → "pb" (2 to < 4 mm)
			Large → "lg" (4 to < 6 mm)
			Headspace → "hs" (> 6 mm)

Sample ID Cross Reference Report



ARI Job No: XJ41
Client: Landau Associates, Inc.
Project Event: 118033.100.104
Project Name: Kaiser IA

Sample ID	ARI Lab ID	ARI LIMS ID	Matrix	Sample Date/Time	VTSR
1. SPL-29-20131010	XJ41A	13-22207	Soil	10/10/13 09:30	10/10/13 13:22
2. SPL-30-20131010	XJ41B	13-22208	Soil	10/10/13 09:40	10/10/13 13:22
3. SPL-31-20131010	XJ41C	13-22209	Soil	10/10/13 10:00	10/10/13 13:22
4. SPL-32-20131010	XJ41D	13-22210	Soil	10/10/13 12:30	10/10/13 13:22
5. SPL-33-20131010	XJ41E	13-22211	Soil	10/10/13 09:00	10/10/13 13:22



Data Reporting Qualifiers

Effective 2/14/2011

Inorganic Data

- U Indicates that the target analyte was not detected at the reported concentration
- * Duplicate RPD is not within established control limits
- B Reported value is less than the CRDL but \geq the Reporting Limit
- N Matrix Spike recovery not within established control limits
- NA Not Applicable, analyte not spiked
- H The natural concentration of the spiked element is so much greater than the concentration spiked that an accurate determination of spike recovery is not possible
- L Analyte concentration is ≤ 5 times the Reporting Limit and the replicate control limit defaults to ± 1 RL instead of the normal 20% RPD

Organic Data

- U Indicates that the target analyte was not detected at the reported concentration
- * Flagged value is not within established control limits
- B Analyte detected in an associated Method Blank at a concentration greater than one-half of ARI's Reporting Limit or 5% of the regulatory limit or 5% of the analyte concentration in the sample.
- J Estimated concentration when the value is less than ARI's established reporting limits
- D The spiked compound was not detected due to sample extract dilution
- E Estimated concentration calculated for an analyte response above the valid instrument calibration range. A dilution is required to obtain an accurate quantification of the analyte.
- Q Indicates a detected analyte with an initial or continuing calibration that does not meet established acceptance criteria ($< 20\%$ RSD, $< 20\%$ Drift or minimum RRF).



- S Indicates an analyte response that has saturated the detector. The calculated concentration is not valid; a dilution is required to obtain valid quantification of the analyte
- NA The flagged analyte was not analyzed for
- NR Spiked compound recovery is not reported due to chromatographic interference
- NS The flagged analyte was not spiked into the sample
- M Estimated value for an analyte detected and confirmed by an analyst but with low spectral match parameters. This flag is used only for GC-MS analyses
- M2 The sample contains PCB congeners that do not match any standard Aroclor pattern. The PCBs are identified and quantified as the Aroclor whose pattern most closely matches that of the sample. The reported value is an estimate.
- N The analysis indicates the presence of an analyte for which there is presumptive evidence to make a "tentative identification"
- Y The analyte is not detected at or above the reported concentration. The reporting limit is raised due to chromatographic interference. The Y flag is equivalent to the U flag with a raised reporting limit.
- EMPC Estimated Maximum Possible Concentration (EMPC) defined in EPA Statement of Work DLM02.2 as a value "calculated for 2,3,7,8-substituted isomers for which the quantitation and /or confirmation ion(s) has signal to noise in excess of 2.5, but does not meet identification criteria" **(Dioxin/Furan analysis only)**
- C The analyte was positively identified on only one of two chromatographic columns. Chromatographic interference prevented a positive identification on the second column
- P The analyte was detected on both chromatographic columns but the quantified values differ by $\geq 40\%$ RPD with no obvious chromatographic interference
- X Analyte signal includes interference from polychlorinated diphenyl ethers. **(Dioxin/Furan analysis only)**
- Z Analyte signal includes interference from the sample matrix or perfluorokerosene ions. **(Dioxin/Furan analysis only)**



Geotechnical Data

- A The total of all fines fractions. This flag is used to report total fines when only sieve analysis is requested and balances total grain size with sample weight.
- F Samples were frozen prior to particle size determination
- SM Sample matrix was not appropriate for the requested analysis. This normally refers to samples contaminated with an organic product that interferes with the sieving process and/or moisture content, porosity and saturation calculations
- SS Sample did not contain the proportion of "fines" required to perform the pipette portion of the grain size analysis
- W Weight of sample in some pipette aliquots was below the level required for accurate weighting

ORGANICS ANALYSIS DATA SHEET

PNAs by SW8270D GC/MS

Page 1 of 1

**Sample ID: SPL-29-20131010
SAMPLE**

Lab Sample ID: XJ41A
LIMS ID: 13-22207
Matrix: Soil
Data Release Authorized: *[Signature]*
Reported: 10/14/13

QC Report No: XJ41-Landau Associates, Inc.
Project: Kaiser IA
118033.100.104
Date Sampled: 10/10/13
Date Received: 10/10/13

Date Extracted: 10/11/13
Date Analyzed: 10/11/13 19:40
Instrument/Analyst: NT6/JZ
GPC Cleanup: No
Alumina: No
Silica Gel: No

Sample Amount: 7.55 g-dry-wt
Final Extract Volume: 0.5 mL
Dilution Factor: 1.00
Percent Moisture: 6.0%

CAS Number	Analyte	RL	Result
56-55-3	Benzo(a)anthracene	66	< 66 U
218-01-9	Chrysene	66	220
50-32-8	Benzo(a)pyrene	66	< 66 U
193-39-5	Indeno(1,2,3-cd)pyrene	66	< 66 U
53-70-3	Dibenz(a,h)anthracene	66	< 66 U
TOTBFA	Total Benzofluoranthenes	66	250

Reported in µg/kg (ppb)

Semivolatile Surrogate Recovery

d14-p-Terphenyl	76.4%
2-Fluorobiphenyl	62.4%

ORGANICS ANALYSIS DATA SHEET

PNAs by SW8270D GC/MS

Page 1 of 1

**Sample ID: SPL-30-20131010
SAMPLE**

Lab Sample ID: XJ41B
LIMS ID: 13-22208
Matrix: Soil
Data Release Authorized:
Reported: 10/14/13

QC Report No: XJ41-Landau Associates, Inc.
Project: Kaiser IA
118033.100.104
Date Sampled: 10/10/13
Date Received: 10/10/13

Date Extracted: 10/11/13
Date Analyzed: 10/11/13 20:14
Instrument/Analyst: NT6/JZ
GPC Cleanup: No
Alumina: No
Silica Gel: No

Sample Amount: 8.08 g-dry-wt
Final Extract Volume: 0.5 mL
Dilution Factor: 1.00
Percent Moisture: 10.6%

CAS Number	Analyte	RL	Result
56-55-3	Benzo (a) anthracene	62	960
218-01-9	Chrysene	62	1,400
50-32-8	Benzo (a) pyrene	62	1,100
193-39-5	Indeno (1,2,3-cd) pyrene	62	730
53-70-3	Dibenz (a,h) anthracene	62	260
TOTBFA	Total Benzofluoranthenes	62	1,600

Reported in µg/kg (ppb)

Semivolatile Surrogate Recovery

d14-p-Terphenyl	74.8%
2-Fluorobiphenyl	62.8%

ORGANICS ANALYSIS DATA SHEET

PNA's by SW8270D GC/MS

Page 1 of 1

**Sample ID: SPL-31-20131010
SAMPLE**

Lab Sample ID: XJ41C

LIMS ID: 13-22209

Matrix: Soil

Data Release Authorized: *B*

Reported: 10/14/13

QC Report No: XJ41-Landau Associates, Inc.

Project: Kaiser IA

118033.100.104

Date Sampled: 10/10/13

Date Received: 10/10/13

Date Extracted: 10/11/13

Date Analyzed: 10/11/13 20:48

Instrument/Analyst: NT6/JZ

GPC Cleanup: No

Alumina: No

Silica Gel: No

Sample Amount: 7.76 g-dry-wt

Final Extract Volume: 0.5 mL

Dilution Factor: 1.00

Percent Moisture: 22.7%

CAS Number	Analyte	RL	Result
56-55-3	Benzo(a)anthracene	64	< 64 U
218-01-9	Chrysene	64	< 64 U
50-32-8	Benzo(a)pyrene	64	< 64 U
193-39-5	Indeno(1,2,3-cd)pyrene	64	< 64 U
53-70-3	Dibenz(a,h)anthracene	64	< 64 U
TOTBFA	Total Benzofluoranthenes	64	< 64 U

Reported in µg/kg (ppb)

Semivolatile Surrogate Recovery

d14-p-Terphenyl	64.8%
2-Fluorobiphenyl	52.0%

ORGANICS ANALYSIS DATA SHEET

PNAs by SW8270D GC/MS

Page 1 of 1

**Sample ID: SPL-32-20131010
SAMPLE**

Lab Sample ID: XJ41D

LIMS ID: 13-22210

Matrix: Soil

Data Release Authorized: *AS*

Reported: 10/14/13

QC Report No: XJ41-Landau Associates, Inc.

Project: Kaiser IA

118033.100.104

Date Sampled: 10/10/13

Date Received: 10/10/13

Date Extracted: 10/11/13

Date Analyzed: 10/11/13 21:22

Instrument/Analyst: NT6/JZ

GPC Cleanup: No

Alumina: No

Silica Gel: No

Sample Amount: 7.62 g-dry-wt

Final Extract Volume: 0.5 mL

Dilution Factor: 1.00

Percent Moisture: 36.9%

CAS Number	Analyte	RL	Result
56-55-3	Benzo(a)anthracene	66	< 66 U
218-01-9	Chrysene	66	< 66 U
50-32-8	Benzo(a)pyrene	66	< 66 U
193-39-5	Indeno(1,2,3-cd)pyrene	66	< 66 U
53-70-3	Dibenz(a,h)anthracene	66	< 66 U
TOTBFA	Total Benzofluoranthenes	66	< 66 U

Reported in µg/kg (ppb)

Semivolatile Surrogate Recovery

d14-p-Terphenyl	44.4%
2-Fluorobiphenyl	47.2%

ORGANICS ANALYSIS DATA SHEET

PNAs by SW8270D GC/MS

Page 1 of 1

Sample ID: SPL-33-20131010

SAMPLE

Lab Sample ID: XJ41E

LIMS ID: 13-22211

Matrix: Soil

Data Release Authorized: 

Reported: 10/14/13

QC Report No: XJ41-Landau Associates, Inc.

Project: Kaiser IA

118033.100.104

Date Sampled: 10/10/13

Date Received: 10/10/13

Date Extracted: 10/11/13

Date Analyzed: 10/11/13 21:55

Instrument/Analyst: NT6/JZ

GPC Cleanup: No

Alumina: No

Silica Gel: No

Sample Amount: 8.43 g-dry-wt

Final Extract Volume: 0.5 mL

Dilution Factor: 1.00

Percent Moisture: 6.6%

CAS Number	Analyte	RL	Result
56-55-3	Benzo(a)anthracene	59	< 59 U
218-01-9	Chrysene	59	< 59 U
50-32-8	Benzo(a)pyrene	59	< 59 U
193-39-5	Indeno(1,2,3-cd)pyrene	59	< 59 U
53-70-3	Dibenz(a,h)anthracene	59	< 59 U
TOTBFA	Total Benzofluoranthenes	59	< 59 U

Reported in µg/kg (ppb)

Semivolatile Surrogate Recovery

d14-p-Terphenyl	68.4%
2-Fluorobiphenyl	52.0%

ORGANICS ANALYSIS DATA SHEET

PNAs by SW8270D GC/MS

Page 1 of 1

Sample ID: MB-101113

METHOD BLANK

Lab Sample ID: MB-101113

LIMS ID: 13-22207

Matrix: Soil

Data Release Authorized: *[Signature]*

Reported: 10/14/13

QC Report No: XJ41-Landau Associates, Inc.

Project: Kaiser IA

118033.100.104

Date Sampled: NA

Date Received: NA

Date Extracted: 10/11/13

Date Analyzed: 10/11/13 17:58

Instrument/Analyst: NT6/JZ

GPC Cleanup: No

Alumina: No

Silica Gel: No

Sample Amount: 7.50 g-dry-wt

Final Extract Volume: 0.5 mL

Dilution Factor: 1.00

Percent Moisture: NA

CAS Number	Analyte	RL	Result
56-55-3	Benzo(a)anthracene	67	< 67 U
218-01-9	Chrysene	67	< 67 U
50-32-8	Benzo(a)pyrene	67	< 67 U
193-39-5	Indeno(1,2,3-cd)pyrene	67	< 67 U
53-70-3	Dibenz(a,h)anthracene	67	< 67 U
TOTBFA	Total Benzofluoranthenes	67	< 67 U

Reported in µg/kg (ppb)

Semivolatile Surrogate Recovery

d14-p-Terphenyl	77.6%
2-Fluorobiphenyl	65.6%

ORGANICS ANALYSIS DATA SHEET

PNAs by SW8270D GC/MS

Page 1 of 1

Sample ID: LCS-101113

LCS/LCSD

Lab Sample ID: LCS-101113

LIMS ID: 13-22207

Matrix: Soil

Data Release Authorized: *B*

Reported: 10/14/13

QC Report No: XJ41-Landau Associates, Inc.

Project: Kaiser IA

118033.100.104

Date Sampled: NA

Date Received: 10/10/13

Date Extracted LCS/LCSD: 10/11/13

Sample Amount LCS: 7.50 g-dry-wt

LCSD: 7.50 g-dry-wt

Date Analyzed LCS: 10/11/13 18:32

Final Extract Volume LCS: 0.50 mL

LCSD: 10/11/13 19:06

LCSD: 0.50 mL

Instrument/Analyst LCS: NT6/JZ

Dilution Factor LCS: 1.00

LCSD: NT6/JZ

LCSD: 1.00

GPC Cleanup: No

Alumina Cleanup: No

Silica Gel Cleanup: No

Analyte	Spike		LCS		Spike		LCSD	
	LCS	Added-LCS	Recovery	LCS	Added-LCSD	Recovery	RPD	
Benzo(a)anthracene	1350	1670	80.8%	1320	1670	79.0%	2.2%	
Chrysene	1310	1670	78.4%	1260	1670	75.4%	3.9%	
Benzo(a)pyrene	1440	1670	86.2%	1410	1670	84.4%	2.1%	
Indeno(1,2,3-cd)pyrene	1450	1670	86.8%	1410	1670	84.4%	2.8%	
Dibenz(a,h)anthracene	1470	1670	88.0%	1430	1670	85.6%	2.8%	
Total Benzofluoranthenes	2730	3330	82.0%	2620	3330	78.7%	4.1%	

Semivolatile Surrogate Recovery

	LCS	LCSD
d14-p-Terphenyl	80.4%	73.2%
2-Fluorobiphenyl	65.2%	58.0%

Results reported in µg/kg

RPD calculated using sample concentrations per SW846.

SW8270 PNA SURROGATE RECOVERY SUMMARY

Matrix: Soil

QC Report No: XJ41-Landau Associates, Inc.
Project: Kaiser IA
118033.100.104

<u>Client ID</u>	<u>TER</u>	<u>FBP</u>	<u>TOT OUT</u>
MB-101113	77.6%	65.6%	0
LCS-101113	80.4%	65.2%	0
LCSD-101113	73.2%	58.0%	0
SPL-29-20131010	76.4%	62.4%	0
SPL-30-20131010	74.8%	62.8%	0
SPL-31-20131010	64.8%	52.0%	0
SPL-32-20131010	44.4%	47.2%	0
SPL-33-20131010	68.4%	52.0%	0

LCS/MB LIMITS QC LIMITS

(TER) = d14-p-Terphenyl (30-160) (30-160)
(FBP) = 2-Fluorobiphenyl (30-160) (30-160)

Prep Method: SW3546
Log Number Range: 13-22207 to 13-22211



Analytical Resources, Incorporated
Analytical Chemists and Consultants

October 17, 2013

Dave Fischer
Landau Associates, Inc.
950 Pacific Ave # 515
Tacoma, WA 98402

RE: Project: Kaiser IA
ARI Job No: XJ86

Dear Dave:

Please find enclosed the original Chain-of-Custody (COC) record, sample receipt documentation, and the analytical results for the samples from the projects referenced above. Analytical Resources, Inc. (ARI) accepted one soil sample on October 15, 2013 in good condition. For further details regarding sample receipt, please refer to the enclosed Cooler Receipt Form.

The samples were analyzed for cPAHs, as requested on the COC.

No analytical complications were noted.

An electronic copy of this report and all associated raw data will remain on file with ARI. If you have any questions or require additional information, please feel free to contact me at your convenience.

Sincerely,
ANALYTICAL RESOURCES, INC.

Kelly Bottem
Client Services Manager
206/695-6211
kellyb@arilabs.com

Enclosures

- Seattle/Edmonds (425) 778-0907
- Tacoma (253) 926-2493
- Spokane (509) 327-9737
- Portland (503) 542-1080

LANDAU ASSOCIATES

XJ86

Date 10/15/13

Page 1 of 1

Chain-of-Custody Record

Project Name Kaiser IA Project No. 118033.100.104
 Project Location/Event Kaiser, Port of Tacoma
 Sampler's Name DAM
 Project Contact Dave Fischer
 Send Results To Anne Halvorsen, Bill Evans, Jessica Stone, Dave Fischer

CPAH 92700

Sample I.D. SPL-35-20B1015 Date 10/15/13 Time 1107 Matrix SoTL No. of Containers 1

Testing Parameters	Observations/Comments	Turnaround Time
	<input checked="" type="checkbox"/> Allow water samples to settle, collect aliquot from clear portion	<input type="checkbox"/> Standard
	<input checked="" type="checkbox"/> NWTPH-Dx - run acid wash/silica gel cleanup	<input type="checkbox"/> Accelerated
	<input type="checkbox"/> run samples standardized to _____ product	<input checked="" type="checkbox"/> 1-2 Day/Tkt
	<input type="checkbox"/> Analyze for EPH if no specific product identified	
	VOC/BTEX/VPH (sol):	
	<input type="checkbox"/> non-preserved	
	<input type="checkbox"/> preserved w/methanol	
	<input type="checkbox"/> preserved w/sodium bisulfate	
	<input type="checkbox"/> Freeze upon receipt	
	<input type="checkbox"/> Dissolved metal water samples field filtered	
	Other _____	

Special Shipment/Handling or Storage Requirements ICE

Method of Shipment Carries

Relinquished by
 Signature 
 Printed Name Don Mallemo
 Company LAI
 Date 10/15/13 Time 1420

Received by
 Signature 
 Printed Name Rich Hudson
 Company ARI
 Date 10/15/13 Time 1420

Relinquished by
 Signature _____
 Printed Name _____
 Company _____
 Date _____ Time _____

Received by
 Signature _____
 Printed Name _____
 Company _____
 Date _____ Time _____

XJ86 : 00002



Cooler Receipt Form

ARI Client: LAI

Project Name: Kaiser IA

COC No(s): _____ (NA)

Delivered by: Fed-Ex UPS Courier Hand Delivered Other: _____

Assigned ARI Job No: XJ86

Tracking No: _____ (NA)

Preliminary Examination Phase:

Were intact, properly signed and dated custody seals attached to the outside of to cooler? YES (NO)

Were custody papers included with the cooler? (YES) NO

Were custody papers properly filled out (ink, signed, etc.) (YES) NO

Temperature of Cooler(s) (°C) (recommended 2.0-6.0 °C for chemistry)
Time: 1515 2.0

If cooler temperature is out of compliance fill out form 00070F
Temp Gun ID#: 90077952

Cooler Accepted by: _____ Date: 10/15/13 Time: H20

Complete custody forms and attach all shipping documents

Log-In Phase:

Was a temperature blank included in the cooler? YES (NO)

What kind of packing material was used? ... Bubble Wrap (Wet Ice) Gel Packs (Baggies) Foam Block Paper Other: _____

Was sufficient ice used (if appropriate)? NA (YES) NO

Were all bottles sealed in individual plastic bags? (YES) NO

Did all bottles arrive in good condition (unbroken)? (YES) NO

Were all bottle labels complete and legible? (YES) NO

Did the number of containers listed on COC match with the number of containers received? (YES) NO

Did all bottle labels and tags agree with custody papers? (YES) NO

Were all bottles used correct for the requested analyses? (YES) NO

Do any of the analyses (bottles) require preservation? (attach preservation sheet, excluding VOCs)... (NA) YES NO

Were all VOC vials free of air bubbles? (NA) YES NO

Was sufficient amount of sample sent in each bottle? (YES) NO

Date VOC Trip Blank was made at ARI... (NA)

Was Sample Split by ARI: (NA) YES Date/Time: _____ Equipment: _____ Split by: _____

Samples Logged by: AV Date: 10/15/13 Time: 1610

**** Notify Project Manager of discrepancies or concerns ****

Sample ID on Bottle	Sample ID on COC	Sample ID on Bottle	Sample ID on COC

Additional Notes, Discrepancies, & Resolutions:

By: _____ Date: _____

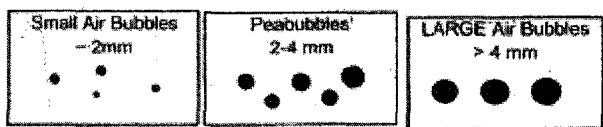

Small → "sm" (< 2 mm)
Peabubbles → "pb" (2 to < 4 mm)
Large → "lg" (4 to < 6 mm)
Headspace → "hs" (> 6 mm)

Sample ID Cross Reference Report



ARI Job No: XJ86
Client: Landau Associates, Inc.
Project Event: 118033.100.104
Project Name: Kaiser IA

Sample ID	ARI Lab ID	ARI LIMS ID	Matrix	Sample Date/Time	VTSR
1. SPL-35-20131015	XJ86A	13-22503	Soil	10/15/13 11:07	10/15/13 14:20

ORGANICS ANALYSIS DATA SHEET
PNAs by SW8270D GC/MS
 Page 1 of 1

Sample ID: SPL-35-20131015
SAMPLE

Lab Sample ID: XJ86A
 LIMS ID: 13-22503
 Matrix: Soil
 Data Release Authorized: *mm*
 Reported: 10/17/13

QC Report No: XJ86-Landau Associates, Inc.
 Project: Kaiser IA
 118033.100.104
 Date Sampled: 10/15/13
 Date Received: 10/15/13

Date Extracted: 10/16/13
 Date Analyzed: 10/16/13 16:17
 Instrument/Analyst: NT6/JZ
 GPC Cleanup: No
 Alumina: No
 Silica Gel: No

Sample Amount: 7.89 g-dry-wt
 Final Extract Volume: 0.5 mL
 Dilution Factor: 1.00
 Percent Moisture: 28.5%

CAS Number	Analyte	RL	Result
56-55-3	Benzo(a)anthracene	63	< 63 U
218-01-9	Chrysene	63	< 63 U
50-32-8	Benzo(a)pyrene	63	< 63 U
193-39-5	Indeno(1,2,3-cd)pyrene	63	< 63 U
53-70-3	Dibenz(a,h)anthracene	63	< 63 U
TOTBFA	Total Benzofluoranthenes	63	< 63 U

Reported in µg/kg (ppb)

Semivolatile Surrogate Recovery

d14-p-Terphenyl	66.8%
2-Fluorobiphenyl	65.2%

ORGANICS ANALYSIS DATA SHEET

PNAs by SW8270D GC/MS

Page 1 of 1

Sample ID: MB-101613

METHOD BLANK

Lab Sample ID: MB-101613

LIMS ID: 13-22503

Matrix: Soil

Data Release Authorized: *mm*

Reported: 10/17/13

QC Report No: XJ86-Landau Associates, Inc.

Project: Kaiser IA

118033.100.104

Date Sampled: NA

Date Received: NA

Date Extracted: 10/16/13

Date Analyzed: 10/16/13 14:35

Instrument/Analyst: NT6/JZ

GPC Cleanup: No

Alumina: No

Silica Gel: No

Sample Amount: 7.50 g-dry-wt

Final Extract Volume: 0.5 mL

Dilution Factor: 1.00

Percent Moisture: NA

CAS Number	Analyte	RL	Result
56-55-3	Benzo(a)anthracene	67	< 67 U
218-01-9	Chrysene	67	< 67 U
50-32-8	Benzo(a)pyrene	67	< 67 U
193-39-5	Indeno(1,2,3-cd)pyrene	67	< 67 U
53-70-3	Dibenz(a,h)anthracene	67	< 67 U
TOTBFA	Total Benzofluoranthenes	67	< 67 U

Reported in µg/kg (ppb)

Semivolatile Surrogate Recovery

d14-p-Terphenyl	76.8%
2-Fluorobiphenyl	64.4%

SW8270 PNA SURROGATE RECOVERY SUMMARY



Matrix: Soil

QC Report No: XJ86-Landau Associates, Inc.
 Project: Kaiser IA
 118033.100.104

<u>Client ID</u>	<u>TER</u>	<u>FBP</u>	<u>TOT OUT</u>
MB-101613	76.8%	64.4%	0
LCS-101613	75.6%	67.2%	0
LCSD-101613	81.6%	67.6%	0
SPL-35-20131015	66.8%	65.2%	0

	<u>LCS/MB LIMITS</u>	<u>QC LIMITS</u>
(TER) = d14-p-Terphenyl	(30-160)	(30-160)
(FBP) = 2-Fluorobiphenyl	(30-160)	(30-160)

Prep Method: SW3546
 Log Number Range: 13-22503 to 13-22503

ORGANICS ANALYSIS DATA SHEET

PNAs by SW8270D GC/MS

Page 1 of 1

Sample ID: LCS-101613

LCS/LCSD

Lab Sample ID: LCS-101613

LIMS ID: 13-22503

Matrix: Soil

Data Release Authorized: *MW*

Reported: 10/17/13

QC Report No: XJ86-Landau Associates, Inc.

Project: Kaiser IA

118033.100.104

Date Sampled: NA

Date Received: 10/15/13

Date Extracted LCS/LCSD: 10/16/13

Sample Amount LCS: 7.50 g-dry-wt

LCSD: 7.50 g-dry-wt

Date Analyzed LCS: 10/16/13 15:09

Final Extract Volume LCS: 0.50 mL

LCSD: 10/16/13 15:43

LCSD: 0.50 mL

Instrument/Analyst LCS: NT6/JZ

Dilution Factor LCS: 1.00

LCSD: NT6/JZ

LCSD: 1.00

GPC Cleanup: No

Alumina Cleanup: No

Silica Gel Cleanup: No

Analyte	Spike			LCSD			RPD
	LCS	Added-LCS	Recovery	LCS	Added-LCSD	Recovery	
Benzo(a)anthracene	1290	1670	77.2%	1440	1670	86.2%	11.0%
Chrysene	1270	1670	76.0%	1410	1670	84.4%	10.4%
Benzo(a)pyrene	1430	1670	85.6%	1600	1670	95.8%	11.2%
Indeno(1,2,3-cd)pyrene	1380	1670	82.6%	1600	1670	95.8%	14.8%
Dibenz(a,h)anthracene	1450	1670	86.8%	1660	1670	99.4%	13.5%
Total Benzofluoranthenes	2680	3330	80.5%	3040	3330	91.3%	12.6%

Semivolatile Surrogate Recovery

	LCS	LCSD
d14-p-Terphenyl	75.6%	81.6%
2-Fluorobiphenyl	67.2%	67.6%

Results reported in µg/kg

RPD calculated using sample concentrations per SW846.



Analytical Resources, Incorporated
Analytical Chemists and Consultants

October 18, 2013

Dave Pischer
Landau Associates, Inc.
950 Pacific Ave # 515
Tacoma, WA 98402

RE: Project: Kaiser IA
ARI Job No: XK04

Dear Dave:

Please find enclosed the original Chain-of-Custody (COC) record, sample receipt documentation, and the analytical results for the samples from the projects referenced above. Analytical Resources, Inc. (ARI) accepted two soil samples on October 16, 2013 in good condition. For further details regarding sample receipt, please refer to the enclosed Cooler Receipt Form.

The samples were analyzed for cPAHs, as requested on the COC.

No analytical complications were noted.

An electronic copy of this report and all associated raw data will remain on file with ARI. If you have any questions or require additional information, please feel free to contact me at your convenience.

Sincerely,
ANALYTICAL RESOURCES, INC.

Kelly Bottem
Client Services Manager
206/695-6211
kellyb@arilabs.com

Enclosures

1 of 9

- Seattle/Edmonds (425) 778-0907
- Tacoma (253) 926-2493
- Spokane (509) 327-9737
- Portland (503) 542-1080



XK04

Date _____
Page 1 of 1

Chain-of-Custody Record

Project Name Kaiser IA Project No. 118033.100.104

Project Location/Event Kaiser, Port of Tacoma

Sampler's Name DAM

Project Contact Dave Fischer

Send Results To Anne Helmsen, Jessica Stone, Bill Evans, Dave Fischer

Sample I.D.	Date	Time	Matrix	No. of Containers	Testing Parameters	Observations/Comments
<u>SPL-34-20131016</u>	<u>10/16/13</u>	<u>1000</u>	<u>SOIL</u>	<u>1</u>		<u>X</u> Allow water samples to settle, collect aliquot from clear portion
<u>SPL-36-20131016</u>	<u>10/16/13</u>	<u>1015</u>	<u>SOIL</u>	<u>1</u>		<u>X</u> NWTPH-Dx - run acid wash/silica gel cleanup
						<u> </u> run samples standardized to _____ product
						<u> </u> Analyze for EPH if no specific product identified
						VOC/BTEX/VPH (soil):
						<u> </u> non-preserved
						<u> </u> preserved w/methanol
						<u> </u> preserved w/sodium bisulfate
						<u> </u> Freeze upon receipt
						<u> </u> Dissolved metal water samples field filtered
						Other _____

Turnaround Time
 Standard
 Accelerated
 1-2 Day

Special Shipment/Handling or Storage Requirements ICE

Relinquished by	Received by	Relinquished by	Received by
Signature <u>Don Mulkenus</u> Printed Name <u>DAM</u> Company _____ Date <u>10/16/13</u> Time <u>1400</u>	Signature <u>[Signature]</u> Printed Name <u>Rich Madro</u> Company <u>ARI</u> Date <u>10/16/13</u> Time <u>1400</u>	Signature _____ Printed Name _____ Company _____ Date _____ Time _____	Signature _____ Printed Name _____ Company _____ Date _____ Time _____

Method of Shipment Carrier

Received by Signature _____
Printed Name _____
Company _____
Date _____ Time _____

XK04 : 00002



Cooler Receipt Form

ARI Client: LAI

Project Name: Kaisey IA

COC No(s): _____ (NA)

Delivered by: Fed-Ex UPS Courier / Hand Delivered Other: _____

Assigned ARI Job No. XK04

Tracking No: _____ (NA)

Preliminary Examination Phase:

Were intact, properly signed and dated custody seals attached to the outside of to cooler? YES (NO)

Were custody papers included with the cooler? (YES) YES NO

Were custody papers properly filled out (ink, signed, etc) (YES) YES NO

Temperature of Cooler(s) (°C) (recommended 2.0-6.0 °C for chemistry) 1.55 1.3

If cooler temperature is out of compliance-fill out form 00070F Temp Gun ID#: 90877952

Cooler Accepted by: _____ Date: 10/16/17 Time: 1400

Complete custody forms and attach all shipping documents

Log-In Phase:

Was a temperature blank included in the cooler? YES (NO)

What kind of packing material was used? ... Bubble Wrap (Wet Ice) Gel Packs (Bags) Foam Block Paper Other: _____

Was sufficient ice used (if appropriate)? NA (YES) YES NO

Were all bottles sealed in individual plastic bags? (YES) YES NO

Did all bottles arrive in good condition (unbroken)? (YES) YES NO

Were all bottle labels complete and legible? (YES) YES NO

Did the number of containers listed on COC match with the number of containers received? (YES) YES NO

Did all bottle labels and tags agree with custody papers? (YES) YES NO

Were all bottles used correct for the requested analyses? (YES) YES NO

Do any of the analyses (bottles) require preservation? (attach preservation sheet, excluding VOCs)... (NA) YES NO

Were all VOC vials free of air bubbles? (NA) YES NO

Was sufficient amount of sample sent in each bottle? (YES) YES NO

Date VOC Trip Blank was made at ARI. (NA) YES NO

Was Sample Split by ARI (NA) YES Date/Time: _____ Equipment: _____ Split by: _____

Samples Logged by: AV Date: 10/16/17 Time: 1503

**** Notify Project Manager of discrepancies or concerns ****

Sample ID on Bottle	Sample ID on COC	Sample ID on Bottle	Sample ID on COC

Additional Notes, Discrepancies, & Resolutions:

By: _____ Date: _____

			Small → "sm" (< 2 mm)
			Peabubbles → "pb" (2 to < 4 mm)
			Large → "lg" (4 to < 6 mm)
			Headspace → "hs" (> 6 mm)

Sample ID Cross Reference Report



ARI Job No: XK04
Client: Landau Associates, Inc.
Project Event: 118033.100.104
Project Name: Kaiser IA

Sample ID	ARI Lab ID	ARI LIMS ID	Matrix	Sample Date/Time	VTSR
1. SPL-34-20131016	XK04A	13-22565	Soil	10/16/13 10:00	10/16/13 14:00
2. SPL-36-20131016	XK04B	13-22566	Soil	10/16/13 10:15	10/16/13 14:00

ORGANICS ANALYSIS DATA SHEET

PNAs by SW8270D GC/MS

Page 1 of 1

Sample ID: SPL-34-20131016

SAMPLE

Lab Sample ID: XK04A

LIMS ID: 13-22565

Matrix: Soil

Data Release Authorized: *mw*

Reported: 10/18/13

QC Report No: XK04-Landau Associates, Inc.

Project: Kaiser IA

118033.100.104

Date Sampled: 10/16/13

Date Received: 10/16/13

Date Extracted: 10/17/13

Date Analyzed: 10/17/13 17:02

Instrument/Analyst: NT6/JZ

GPC Cleanup: No

Alumina: No

Silica Gel: No

Sample Amount: 7.96 g-dry-wt

Final Extract Volume: 0.5 mL

Dilution Factor: 1.00

Percent Moisture: 27.7%

CAS Number	Analyte	RL	Result
56-55-3	Benzo(a)anthracene	63	< 63 U
218-01-9	Chrysene	63	< 63 U
50-32-8	Benzo(a)pyrene	63	< 63 U
193-39-5	Indeno(1,2,3-cd)pyrene	63	< 63 U
53-70-3	Dibenz(a,h)anthracene	63	< 63 U
TOTBFA	Total Benzofluoranthenes	63	< 63 U

Reported in µg/kg (ppb)

Semivolatile Surrogate Recovery

d14-p-Terphenyl	60.0%
2-Fluorobiphenyl	60.0%

ORGANICS ANALYSIS DATA SHEET

PNAs by SW8270D GC/MS

Page 1 of 1

Sample ID: SPL-36-20131016

SAMPLE

Lab Sample ID: XK04B

LIMS ID: 13-22566

Matrix: Soil

Data Release Authorized: *mmw*

Reported: 10/18/13

QC Report No: XK04-Landau Associates, Inc.

Project: Kaiser IA

118033.100.104

Date Sampled: 10/16/13

Date Received: 10/16/13

Date Extracted: 10/17/13

Date Analyzed: 10/17/13 17:36

Instrument/Analyst: NT6/JZ

GPC Cleanup: No

Alumina: No

Silica Gel: No

Sample Amount: 8.10 g-dry-wt

Final Extract Volume: 0.5 mL

Dilution Factor: 1.00

Percent Moisture: 32.6%

CAS Number	Analyte	RL	Result
56-55-3	Benzo(a)anthracene	62	< 62 U
218-01-9	Chrysene	62	< 62 U
50-32-8	Benzo(a)pyrene	62	< 62 U
193-39-5	Indeno(1,2,3-cd)pyrene	62	< 62 U
53-70-3	Dibenz(a,h)anthracene	62	< 62 U
TOTBFA	Total Benzofluoranthenes	62	< 62 U

Reported in µg/kg (ppb)

Semivolatile Surrogate Recovery

d14-p-Terphenyl	53.6%
2-Fluorobiphenyl	58.8%

ORGANICS ANALYSIS DATA SHEET

PNAs by SW8270D GC/MS

Page 1 of 1

Sample ID: MB-101713

METHOD BLANK

Lab Sample ID: MB-101713

LIMS ID: 13-22565

Matrix: Soil

Data Release Authorized: *MMW*

Reported: 10/18/13

QC Report No: XK04-Landau Associates, Inc.

Project: Kaiser IA

118033.100.104

Date Sampled: NA

Date Received: NA

Date Extracted: 10/17/13

Date Analyzed: 10/17/13 15:20

Instrument/Analyst: NT6/JZ

GPC Cleanup: No

Alumina: No

Silica Gel: No

Sample Amount: 7.50 g-dry-wt

Final Extract Volume: 0.5 mL

Dilution Factor: 1.00

Percent Moisture: NA

CAS Number	Analyte	RL	Result
56-55-3	Benzo(a)anthracene	67	< 67 U
218-01-9	Chrysene	67	< 67 U
50-32-8	Benzo(a)pyrene	67	< 67 U
193-39-5	Indeno(1,2,3-cd)pyrene	67	< 67 U
53-70-3	Dibenz(a,h)anthracene	67	< 67 U
TOTBFA	Total Benzofluoranthenes	67	< 67 U

Reported in µg/kg (ppb)

Semivolatile Surrogate Recovery

d14-p-Terphenyl	74.0%
2-Fluorobiphenyl	58.8%

SW8270 PNA SURROGATE RECOVERY SUMMARY



Matrix: Soil

QC Report No: XK04-Landau Associates, Inc.
 Project: Kaiser IA
 118033.100.104

<u>Client ID</u>	<u>TER</u>	<u>FBP</u>	<u>TOT OUT</u>
MB-101713	74.0%	58.8%	0
LCS-101713	81.2%	60.8%	0
LCSD-101713	76.8%	64.0%	0
SPL-34-20131016	60.0%	60.0%	0
SPL-36-20131016	53.6%	58.8%	0

LCS/MB LIMITS QC LIMITS

(TER) = d14-p-Terphenyl (30-160) (30-160)
 (FBP) = 2-Fluorobiphenyl (30-160) (30-160)

Prep Method: SW3546
 Log Number Range: 13-22565 to 13-22566

ORGANICS ANALYSIS DATA SHEET

PNAs by SW8270D GC/MS

Page 1 of 1

Sample ID: LCS-101713

LCS/LCSD

Lab Sample ID: LCS-101713
LIMS ID: 13-22565
Matrix: Soil
Data Release Authorized: *mmw*
Reported: 10/18/13

QC Report No: XK04-Landau Associates, Inc.
Project: Kaiser IA
118033.100.104
Date Sampled: NA
Date Received: 10/16/13

Date Extracted LCS/LCSD: 10/17/13

Sample Amount LCS: 7.50 g-dry-wt

LCSD: 7.50 g-dry-wt

Date Analyzed LCS: 10/17/13 15:54

Final Extract Volume LCS: 0.50 mL

LCSD: 10/17/13 16:28

LCSD: 0.50 mL

Instrument/Analyst LCS: NT6/JZ

Dilution Factor LCS: 1.00

LCSD: NT6/JZ

LCSD: 1.00

GPC Cleanup: No

Alumina Cleanup: No

Silica Gel Cleanup: No

Analyte	LCS			LCSD			RPD
	LCS	Spike Added-LCS	LCS Recovery	LCSD	Spike Added-LCSD	LCSD Recovery	
Benzo(a)anthracene	1350	1670	80.8%	1320	1670	79.0%	2.2%
Chrysene	1330	1670	79.6%	1320	1670	79.0%	0.8%
Benzo(a)pyrene	1470	1670	88.0%	1460	1670	87.4%	0.7%
Indeno(1,2,3-cd)pyrene	1500	1670	89.8%	1420	1670	85.0%	5.5%
Dibenz(a,h)anthracene	1570	1670	94.0%	1490	1670	89.2%	5.2%
Total Benzofluoranthenes	2940	3330	88.3%	2830	3330	85.0%	3.8%

Semivolatile Surrogate Recovery

	LCS	LCSD
d14-p-Terphenyl	81.2%	76.8%
2-Fluorobiphenyl	60.8%	64.0%

Results reported in µg/kg
RPD calculated using sample concentrations per SW846.



Analytical Resources, Incorporated
Analytical Chemists and Consultants

October 23, 2013

Dave Pischer
Landau Associates, Inc.
950 Pacific Ave # 515
Tacoma, WA 98402

RE: Project: Kaiser IA
ARI Job No: XK75

Dear Dave:

Please find enclosed the original Chain-of-Custody (COC) record, sample receipt documentation, and the analytical results for the samples from the projects referenced above. Analytical Resources, Inc. (ARI) accepted four soil samples on October 21, 2013 in good condition. For further details regarding sample receipt, please refer to the enclosed Cooler Receipt Form.

The samples were analyzed for cPAHs, as requested on the COC.

No analytical complications were noted.

An electronic copy of this report and all associated raw data will remain on file with ARI. If you have any questions or require additional information, please feel free to contact me at your convenience.

Sincerely,
ANALYTICAL RESOURCES, INC.

Kelly Bottem
Client Services Manager
206/695-6211
kellyb@arilabs.com

Enclosures

1 of 11

- Seattle/Edmonds (425) 778-0907
- Tacoma (253) 926-2493
- Spokane (509) 327-9737
- Portland (503) 542-1080



Chain-of-Custody Record

Date 10/21/2013
Page 1 of 1

Project Name <u>Kaiser I A</u> Project No. <u>18033.100.104</u>		Turnaround Time <input type="checkbox"/> Standard <input type="checkbox"/> Accelerated <input checked="" type="checkbox"/> <u>1-2 Day JAT</u>				
Project Location/Event <u>Kaiser, Port of Tacoma</u>		Testing Parameters				
Sampler's Name <u>DAR, Dave Rupert</u>		Observations/Comments <input checked="" type="checkbox"/> Allow water samples to settle, collect aliquot from clear portion <input checked="" type="checkbox"/> NWTPH-DX - run acid wash/silica gel cleanup <input type="checkbox"/> run samples standardized to _____ product <input type="checkbox"/> Analyze for EPH if no specific product identified VOC/BTEX/VPH (soil): <input type="checkbox"/> non-preserved <input type="checkbox"/> preserved w/methanol <input type="checkbox"/> preserved w/sodium bisulfate <input type="checkbox"/> Freeze upon receipt <input type="checkbox"/> Dissolved metal water samples field filtered Other _____ 				
Project Contact <u>Dave Fischer</u>						
Send Results To <u>Anne Halvorsen, Jess Steing, Bill Evans, Sierra Mott, Dave Fischer</u>						
Sample I.D.	Date			Time	Matrix	No. of Containers
<u>SPL-39-2013</u>	<u>10/21/13</u>			<u>10:40</u>	<u>Soil</u>	<u>1</u>
<u>SPL-40-2013</u>	<u>10/21/13</u>	<u>10:51</u>	<u>Soil</u>	<u>1</u>		
<u>SPL-41-2013</u>	<u>10/21/13</u>	<u>11:16</u>	<u>Soil</u>	<u>1</u>		
<u>SPL-42-2013</u>	<u>10/21/13</u>	<u>11:28</u>	<u>Soil</u>	<u>1</u>		
Chain-of-Custody						
Special Shipment/Handling or Storage Requirements						
Received by <u>Brittany N Gordon</u> Signature <u>Brittany N Gordon</u> Printed Name <u>LAI</u> Company		Received by <u>R. G. Hudson</u> Signature <u>ARI</u> Printed Name <u>LAI</u> Company		Relinquished by Signature Printed Name Company		
Date <u>10/21/13</u> Time <u>1648</u>		Date <u>10/21/13</u> Time <u>650</u>		Date _____ Time _____		
Method of Shipment <u>Courier</u>						

XK75 : 00002



Cooler Receipt Form

ARI Client: LAI

Project Name: Ka. >er IA

COC No(s): _____ NA

Delivered by: Fed-Ex UPS Courier (Circled) Hand Delivered Other: _____

Assigned ARI Job No: XK75

Tracking No: _____ NA

Preliminary Examination Phase:

Were intact, properly signed and dated custody seals attached to the outside of to cooler? YES NO
 Were custody papers included with the cooler? YES NO
 Were custody papers properly filled out (ink, signed, etc.) YES NO

Temperature of Cooler(s) (°C) (recommended 2.0-6.0 °C for chemistry)
 Time: 1740

If cooler temperature is out of compliance fill out form 00070F

Temp Gun ID#: 90877952
S.G.
10/21/13 Date: _____ Time: 1650

Cooler Accepted by: _____

Complete custody forms and attach all shipping documents

Log-In Phase:

Was a temperature blank included in the cooler? YES NO
 What kind of packing material was used? ... Bubble Wrap Wet Ice Gel Packs Raggies Foam Block Paper Other: _____
 Was sufficient ice used (if appropriate)? _____ NA YES NO
 Were all bottles sealed in individual plastic bags? _____ YES NO
 Did all bottles arrive in good condition (unbroken)? _____ YES NO
 Were all bottle labels complete and legible? _____ YES NO
 Did the number of containers listed on COC match with the number of containers received? _____ YES NO
 Did all bottle labels and tags agree with custody papers? _____ YES NO
 Were all bottles used correct for the requested analyses? _____ YES NO
 Do any of the analyses (bottles) require preservation? (attach preservation sheet, excluding VOCs)... NA YES NO
 Were all VOC vials free of air bubbles? _____ NA YES NO
 Was sufficient amount of sample sent in each bottle? _____ YES NO
 Date VOC Trip Blank was made at ARI: _____ NA
 Was Sample Split by ARI: NA YES Date/Time: _____ Equipment: _____ Split by: _____
TS

Samples Logged by: _____ Date: 10-22-13 Time: 804

**** Notify Project Manager of discrepancies or concerns ****

Sample ID on Bottle	Sample ID on COC	Sample ID on Bottle	Sample ID on COC

Additional Notes, Discrepancies, & Resolutions:

By: _____ Date: _____

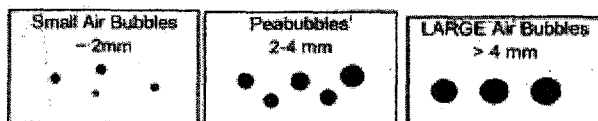

Small → "sm" (< 2 mm)
 Peabubbles → "pb" (2 to < 4 mm)
 Large → "lg" (4 to < 6 mm)
 Headspace → "hs" (> 6 mm)

Sample ID Cross Reference Report



ARI Job No: XK75
Client: Landau Associates, Inc.
Project Event: 118033.100.104
Project Name: Kaiser IA

Sample ID	ARI Lab ID	ARI LIMS ID	Matrix	Sample Date/Time	VTSR
1. SPL-39-20131021	XK75A	13-23125	Soil	10/21/13 10:40	10/21/13 16:50
2. SPL-40-20131021	XK75B	13-23126	Soil	10/21/13 10:51	10/21/13 16:50
3. SPL-41-20131021	XK75C	13-23127	Soil	10/21/13 11:16	10/21/13 16:50
4. SPL-42-20131021	XK75D	13-23128	Soil	10/21/13 11:28	10/21/13 16:50

ORGANICS ANALYSIS DATA SHEET

PNA's by SW8270D GC/MS

Page 1 of 1

Sample ID: SPL-39-20131021

SAMPLE

Lab Sample ID: XK75A

LIMS ID: 13-23125

Matrix: Soil

Data Release Authorized: 

Reported: 10/23/13

QC Report No: XK75-Landau Associates, Inc.

Project: Kaiser IA

118033.100.104

Date Sampled: 10/21/13

Date Received: 10/21/13

Date Extracted: 10/22/13

Date Analyzed: 10/22/13 17:49

Instrument/Analyst: NT6/JZ

GPC Cleanup: No

Alumina: No

Silica Gel: No

Sample Amount: 8.21 g-dry-wt

Final Extract Volume: 0.5 mL

Dilution Factor: 1.00

Percent Moisture: 25.7%

CAS Number	Analyte	RL	Result
56-55-3	Benzo(a)anthracene	61	< 61 U
218-01-9	Chrysene	61	< 61 U
50-32-8	Benzo(a)pyrene	61	< 61 U
193-39-5	Indeno(1,2,3-cd)pyrene	61	< 61 U
53-70-3	Dibenz(a,h)anthracene	61	< 61 U
TOTBFA	Total Benzofluoranthenes	61	< 61 U

Reported in µg/kg (ppb)

Semivolatile Surrogate Recovery

d14-p-Terphenyl	44.4%
2-Fluorobiphenyl	44.0%

ORGANICS ANALYSIS DATA SHEET

PNA's by SW8270D GC/MS

Page 1 of 1

Sample ID: SPL-40-20131021

SAMPLE

Lab Sample ID: XK75B

LIMS ID: 13-23126

Matrix: Soil

Data Release Authorized: *MS*

Reported: 10/23/13

QC Report No: XK75-Landau Associates, Inc.

Project: Kaiser IA

118033.100.104

Date Sampled: 10/21/13

Date Received: 10/21/13

Date Extracted: 10/22/13

Date Analyzed: 10/22/13 18:23

Instrument/Analyst: NT6/JZ

GPC Cleanup: No

Alumina: No

Silica Gel: No

Sample Amount: 7.78 g-dry-wt

Final Extract Volume: 0.5 mL

Dilution Factor: 1.00

Percent Moisture: 22.4%

CAS Number	Analyte	RL	Result
56-55-3	Benzo(a)anthracene	64	< 64 U
218-01-9	Chrysene	64	< 64 U
50-32-8	Benzo(a)pyrene	64	< 64 U
193-39-5	Indeno(1,2,3-cd)pyrene	64	< 64 U
53-70-3	Dibenz(a,h)anthracene	64	< 64 U
TOTBFA	Total Benzofluoranthenes	64	< 64 U

Reported in µg/kg (ppb)

Semivolatiles Surrogate Recovery

d14-p-Terphenyl	61.6%
2-Fluorobiphenyl	58.0%

ORGANICS ANALYSIS DATA SHEET

PNA's by SW8270D GC/MS

Page 1 of 1

Sample ID: SPL-41-20131021

SAMPLE

Lab Sample ID: XK75C

LIMS ID: 13-23127

Matrix: Soil

Data Release Authorized: *AS*

Reported: 10/23/13

QC Report No: XK75-Landau Associates, Inc.

Project: Kaiser IA

118033.100.104

Date Sampled: 10/21/13

Date Received: 10/21/13

Date Extracted: 10/22/13

Date Analyzed: 10/22/13 18:57

Instrument/Analyst: NT6/JZ

GPC Cleanup: No

Alumina: No

Silica Gel: No

Sample Amount: 7.60 g-dry-wt

Final Extract Volume: 0.5 mL

Dilution Factor: 1.00

Percent Moisture: 5.4%

CAS Number	Analyte	RL	Result
56-55-3	Benzo(a)anthracene	66	< 66 U
218-01-9	Chrysene	66	< 66 U
50-32-8	Benzo(a)pyrene	66	< 66 U
193-39-5	Indeno(1,2,3-cd)pyrene	66	< 66 U
53-70-3	Dibenz(a,h)anthracene	66	< 66 U
TOTBFA	Total Benzofluoranthenes	66	< 66 U

Reported in µg/kg (ppb)

Semivolatile Surrogate Recovery

d14-p-Terphenyl	67.2%
2-Fluorobiphenyl	56.0%

ORGANICS ANALYSIS DATA SHEET

PNA's by SW8270D GC/MS

Page 1 of 1

Sample ID: SPL-42-20131021

SAMPLE

Lab Sample ID: XK75D

LIMS ID: 13-23128

Matrix: Soil

Data Release Authorized: *[Signature]*

Reported: 10/23/13

QC Report No: XK75-Landau Associates, Inc.

Project: Kaiser IA

118033.100.104

Date Sampled: 10/21/13

Date Received: 10/21/13

Date Extracted: 10/22/13

Date Analyzed: 10/22/13 19:30

Instrument/Analyst: NT6/JZ

GPC Cleanup: No

Alumina: No

Silica Gel: No

Sample Amount: 7.76 g-dry-wt

Final Extract Volume: 0.5 mL

Dilution Factor: 1.00

Percent Moisture: 22.5%

CAS Number	Analyte	RL	Result
56-55-3	Benzo(a)anthracene	64	< 64 U
218-01-9	Chrysene	64	< 64 U
50-32-8	Benzo(a)pyrene	64	< 64 U
193-39-5	Indeno(1,2,3-cd)pyrene	64	< 64 U
53-70-3	Dibenz(a,h)anthracene	64	< 64 U
TOTBFA	Total Benzofluoranthenes	64	< 64 U

Reported in µg/kg (ppb)

Semivolatile Surrogate Recovery

d14-p-Terphenyl	55.6%
2-Fluorobiphenyl	42.4%

ORGANICS ANALYSIS DATA SHEET

PNA's by SW8270D GC/MS

Page 1 of 1

Sample ID: MB-102213

METHOD BLANK

Lab Sample ID: MB-102213

LIMS ID: 13-23125

Matrix: Soil

Data Release Authorized: *AS*

Reported: 10/23/13

QC Report No: XK75-Landau Associates, Inc.

Project: Kaiser IA

118033.100.104

Date Sampled: NA

Date Received: NA

Date Extracted: 10/22/13

Date Analyzed: 10/22/13 16:07

Instrument/Analyst: NT6/JZ

GPC Cleanup: No

Alumina: No

Silica Gel: No

Sample Amount: 7.50 g-dry-wt

Final Extract Volume: 0.5 mL

Dilution Factor: 1.00

Percent Moisture: NA

CAS Number	Analyte	RL	Result
56-55-3	Benzo(a)anthracene	67	< 67 U
218-01-9	Chrysene	67	< 67 U
50-32-8	Benzo(a)pyrene	67	< 67 U
193-39-5	Indeno(1,2,3-cd)pyrene	67	< 67 U
53-70-3	Dibenz(a,h)anthracene	67	< 67 U
TOTBFA	Total Benzofluoranthenes	67	< 67 U

Reported in µg/kg (ppb)

Semivolatile Surrogate Recovery

d14-p-Terphenyl	68.0%
2-Fluorobiphenyl	56.8%

SW8270 PNA SURROGATE RECOVERY SUMMARY



Matrix: Soil

QC Report No: XK75-Landau Associates, Inc.
 Project: Kaiser IA
 118033.100.104

Client ID	TER	FBP	TOT OUT
MB-102213	68.0%	56.8%	0
LCS-102213	75.2%	64.0%	0
LCSD-102213	72.4%	61.6%	0
SPL-39-20131021	44.4%	44.0%	0
SPL-40-20131021	61.6%	58.0%	0
SPL-41-20131021	67.2%	56.0%	0
SPL-42-20131021	55.6%	42.4%	0

	LCS/MB LIMITS	QC LIMITS
(TER) = d14-p-Terphenyl	(30-160)	(30-160)
(FBP) = 2-Fluorobiphenyl	(30-160)	(30-160)

Prep Method: SW3546
 Log Number Range: 13-23125 to 13-23128

ORGANICS ANALYSIS DATA SHEET

PNAs by SW8270D GC/MS

Page 1 of 1

Sample ID: LCS-102213

LCS/LCSD

Lab Sample ID: LCS-102213

LIMS ID: 13-23125

Matrix: Soil

Data Release Authorized: *[Signature]*

Reported: 10/23/13

QC Report No: XK75-Landau Associates, Inc.

Project: Kaiser IA

118033.100.104

Date Sampled: NA

Date Received: 10/21/13

Date Extracted LCS/LCSD: 10/22/13

Sample Amount LCS: 7.50 g-dry-wt

LCSD: 7.50 g-dry-wt

Date Analyzed LCS: 10/22/13 16:41

Final Extract Volume LCS: 0.50 mL

LCSD: 10/22/13 17:15

LCSD: 0.50 mL

Instrument/Analyst LCS: NT6/JZ

Dilution Factor LCS: 1.00

LCSD: NT6/JZ

LCSD: 1.00

GPC Cleanup: No

Alumina Cleanup: No

Silica Gel Cleanup: No

Analyte	Spike		LCS		Spike		LCSD	
	LCS	Added-LCS	Recovery	LCS	Added-LCSD	Recovery	RPD	
Benzo(a)anthracene	1260	1670	75.4%	1260	1670	75.4%	0.0%	
Chrysene	1230	1670	73.7%	1220	1670	73.1%	0.8%	
Benzo(a)pyrene	1360	1670	81.4%	1360	1670	81.4%	0.0%	
Indeno(1,2,3-cd)pyrene	1330	1670	79.6%	1320	1670	79.0%	0.8%	
Dibenz(a,h)anthracene	1360	1670	81.4%	1330	1670	79.6%	2.2%	
Total Benzofluoranthenes	2600	3330	78.1%	2550	3330	76.6%	1.9%	

Semivolatile Surrogate Recovery

	LCS	LCSD
d14-p-Terphenyl	75.2%	72.4%
2-Fluorobiphenyl	64.0%	61.6%

Results reported in µg/kg

RPD calculated using sample concentrations per SW846.



Analytical Resources, Incorporated
Analytical Chemists and Consultants

October 25, 2013

Dave Pischer
Landau Associates, Inc.
950 Pacific Ave # 515
Tacoma, WA 98402

RE: Project: Kaiser IA
ARI Job No: XL11

Dear Dave:

Please find enclosed the original Chain-of-Custody (COC) record, sample receipt documentation, and the analytical results for the samples from the projects referenced above. Analytical Resources, Inc. (ARI) accepted three soil samples on October 23, 2013 in good condition. For further details regarding sample receipt, please refer to the enclosed Cooler Receipt Form.

The samples were analyzed for cPAHs, as requested on the COC.

No analytical complications were noted.

An electronic copy of this report and all associated raw data will remain on file with ARI. If you have any questions or require additional information, please feel free to contact me at your convenience.

Sincerely,
ANALYTICAL RESOURCES, INC.

A handwritten signature in black ink, appearing to read "Kelly Bottem".

Kelly Bottem
Client Services Manager
206/695-6211
kellyb@arilabs.com

Enclosures

1 of 10

- Seattle/Edmonds (425) 778-0907
- Tacoma (253) 926-2493
- Spokane (509) 327-9737
- Portland (503) 542-1080



Chain-of-Custody Record

Date 10/23/2013
 Page 1 of 1

Project Name Kaiser IA Project No. 118033.100.104

Project Location/Event Port of Tacoma

Sampler's Name DAR

Project Contact DAVE FISCHER

Send Results To Jess Stone, Sierra Moth, Bill Ewins, Dave Fischer

Testing Parameters

Turnaround Time
 Standard
 Accelerated
 1-2 Day TAT

PAH 8270 v

Sample I.D.	Date	Time	Matrix	No. of Containers	Observations/Comments
SPL-43-20131023	10/23/13	9:27	Soil	1	X Allow water samples to settle, collect aliquot from clear portion
SPL-30-20131023	10/23/13	9:44	↓	1	X NWTPH-Dx - run acid wash/silica gel cleanup
SPL-29-20131023	10/23/13	9:55	↓	1	run samples standardized to _____ product
					Analyze for EPH if no specific product identified
					VOC/BTEX/VPH (soil):
					non-preserved
					preserved w/methanol
					preserved w/sodium bisulfate
					Freeze upon receipt
					Dissolved metal water samples field filtered
					Other _____

Special Shipment/Handling or Storage Requirements On Ice

Method of Shipment Courier

Relinquished by
 Signature David Rupert
 Printed Name David Rupert
 Company Landau Assoc., Inc
 Date 10/23/13 Time 14:08

Received by
 Signature [Signature]
 Printed Name Rich Walker
 Company ARI
 Date 10/23/13 Time 1410

Relinquished by
 Signature _____
 Printed Name _____
 Company _____
 Date _____ Time _____

Received by
 Signature _____
 Printed Name _____
 Company _____
 Date _____ Time _____



Cooler Receipt Form

ARI Client LAN

Project Name: Kaiser IA

COC No(s): _____ (NA)

Delivered by: Fed-Ex UPS (Courier) Hand Delivered Other: _____

Assigned ARI Job No: XL11

Tracking No: _____ NA

Preliminary Examination Phase:

Were intact, properly signed and dated custody seals attached to the outside of to cooler? YES NO
 Were custody papers included with the cooler? YES NO
 Were custody papers properly filled out (ink, signed, etc.) YES NO

Temperature of Cooler(s) (°C) (recommended 2.0-6.0 °C for chemistry)

Time: 1645

If cooler temperature is out of compliance fill out form 00070F

Temp Gun ID#: 90877952 ^{3.4}

Cooler Accepted by: _____ Date: 10/23/13 Time: 1410

Complete custody forms and attach all shipping documents

Log-In Phase:

Was a temperature blank included in the cooler? YES NO
 What kind of packing material was used? ... Bubble Wrap Wet Ice Gel Packs Baggies Foam Block Paper Other: _____
 Was sufficient ice used (if appropriate)? _____ NA YES NO
 Were all bottles sealed in individual plastic bags? YES NO
 Did all bottles arrive in good condition (unbroken)? YES NO
 Were all bottle labels complete and legible? YES NO
 Did the number of containers listed on COC match with the number of containers received? YES NO
 Did all bottle labels and tags agree with custody papers? YES NO
 Were all bottles used correct for the requested analyses? YES NO
 Do any of the analyses (bottles) require preservation? (attach preservation sheet, excluding VOCs). NA YES NO
 Were all VOC vials free of air bubbles? NA YES NO
 Was sufficient amount of sample sent in each bottle? YES NO
 Date VOC Trip Blank was made at ARI. NA _____
 Was Sample Split by ARI NA YES Date/Time: _____ Equipment: _____ Split by: _____

Samples Logged by: JM Date: 10/23/13 Time: 1655

**** Notify Project Manager of discrepancies or concerns ****

Sample ID on Bottle	Sample ID on COC	Sample ID on Bottle	Sample ID on COC

Additional Notes, Discrepancies, & Resolutions:

By: _____ Date: _____

 Small Air Bubbles ~2mm	 Peabubbles 2-4 mm	 LARGE Air Bubbles > 4 mm	Small → "sm" (< 2 mm)
			Peabubbles → "pb" (2 to < 4 mm)
			Large → "lg" (4 to < 6 mm)
			Headspace → "hs" (> 6 mm)

Sample ID Cross Reference Report



ARI Job No: XL11
Client: Landau Associates, Inc.
Project Event: 118033.100.104
Project Name: Kaiser IA

Sample ID	ARI Lab ID	ARI LIMS ID	Matrix	Sample Date/Time	VTSR
1. SPL-43-20131023	XL11A	13-23308	Soil	10/23/13 09:27	10/23/13 14:10
2. SPL-30-20131023	XL11B	13-23309	Soil	10/23/13 09:44	10/23/13 14:10
3. SPL-29-20131023	XL11C	13-23310	Soil	10/23/13 09:55	10/23/13 14:10

ORGANICS ANALYSIS DATA SHEET

PNAs by SW8270D GC/MS

Page 1 of 1

Sample ID: SPL-43-20131023

SAMPLE

Lab Sample ID: XL11A

LIMS ID: 13-23308

Matrix: Soil

Data Release Authorized: 

Reported: 10/25/13

QC Report No: XL11-Landau Associates, Inc.

Project: Kaiser IA

118033.100.104

Date Sampled: 10/23/13

Date Received: 10/23/13

Date Extracted: 10/24/13

Date Analyzed: 10/24/13 17:58

Instrument/Analyst: NT6/JZ

GPC Cleanup: No

Alumina: No

Silica Gel: No

Sample Amount: 8.21 g-dry-wt

Final Extract Volume: 0.5 mL

Dilution Factor: 1.00

Percent Moisture: 25.4%

CAS Number	Analyte	RL	Result
56-55-3	Benzo(a)anthracene	61	< 61 U
218-01-9	Chrysene	61	< 61 U
50-32-8	Benzo(a)pyrene	61	< 61 U
193-39-5	Indeno(1,2,3-cd)pyrene	61	< 61 U
53-70-3	Dibenz(a,h)anthracene	61	< 61 U
TOTBFA	Total Benzofluoranthenes	61	< 61 U

Reported in µg/kg (ppb)

Semivolatile Surrogate Recovery

d14-p-Terphenyl	73.2%
2-Fluorobiphenyl	62.4%

ORGANICS ANALYSIS DATA SHEET

PNAs by SW8270D GC/MS

Page 1 of 1

Sample ID: SPL-30-20131023

SAMPLE

Lab Sample ID: XL11B

LIMS ID: 13-23309

Matrix: Soil

Data Release Authorized: 

Reported: 10/25/13

QC Report No: XL11-Landau Associates, Inc.

Project: Kaiser IA

118033.100.104

Date Sampled: 10/23/13

Date Received: 10/23/13

Date Extracted: 10/24/13

Date Analyzed: 10/24/13 18:32

Instrument/Analyst: NT6/JZ

GPC Cleanup: No

Alumina: No

Silica Gel: No

Sample Amount: 8.29 g-dry-wt

Final Extract Volume: 0.5 mL

Dilution Factor: 1.00

Percent Moisture: 17.3%

CAS Number	Analyte	RL	Result
56-55-3	Benzo(a)anthracene	60	< 60 U
218-01-9	Chrysene	60	< 60 U
50-32-8	Benzo(a)pyrene	60	< 60 U
193-39-5	Indeno(1,2,3-cd)pyrene	60	< 60 U
53-70-3	Dibenz(a,h)anthracene	60	< 60 U
TOTBFA	Total Benzofluoranthenes	60	< 60 U

Reported in µg/kg (ppb)

Semivolatile Surrogate Recovery

d14-p-Terphenyl	75.6%
2-Fluorobiphenyl	63.2%

ORGANICS ANALYSIS DATA SHEET

PNAs by SW8270D GC/MS

Page 1 of 1

Sample ID: SPL-29-20131023

SAMPLE

Lab Sample ID: XL11C

LIMS ID: 13-23310

Matrix: Soil

Data Release Authorized: *AB*

Reported: 10/25/13

QC Report No: XL11-Landau Associates, Inc.

Project: Kaiser IA

118033.100.104

Date Sampled: 10/23/13

Date Received: 10/23/13

Date Extracted: 10/24/13

Date Analyzed: 10/24/13 19:05

Instrument/Analyst: NT6/JZ

GPC Cleanup: No

Alumina: No

Silica Gel: No

Sample Amount: 8.14 g-dry-wt

Final Extract Volume: 0.5 mL

Dilution Factor: 1.00

Percent Moisture: 26.1%

CAS Number	Analyte	RL	Result
56-55-3	Benzo(a)anthracene	61	< 61 U
218-01-9	Chrysene	61	< 61 U
50-32-8	Benzo(a)pyrene	61	< 61 U
193-39-5	Indeno(1,2,3-cd)pyrene	61	< 61 U
53-70-3	Dibenz(a,h)anthracene	61	< 61 U
TOTBFA	Total Benzofluoranthenes	61	< 61 U

Reported in µg/kg (ppb)

Semivolatile Surrogate Recovery

d14-p-Terphenyl	76.4%
2-Fluorobiphenyl	68.0%

ORGANICS ANALYSIS DATA SHEET

PNAs by SW8270D GC/MS

Page 1 of 1

Sample ID: MB-102413

METHOD BLANK

Lab Sample ID: MB-102413

LIMS ID: 13-23308

Matrix: Soil

Data Release Authorized: 

Reported: 10/25/13

QC Report No: XL11-Landau Associates, Inc.

Project: Kaiser IA

118033.100.104

Date Sampled: NA

Date Received: NA

Date Extracted: 10/24/13

Date Analyzed: 10/24/13 16:16

Instrument/Analyst: NT6/JZ

GPC Cleanup: No

Alumina: No

Silica Gel: No

Sample Amount: 7.50 g-dry-wt

Final Extract Volume: 0.5 mL

Dilution Factor: 1.00

Percent Moisture: NA

CAS Number	Analyte	RL	Result
56-55-3	Benzo(a)anthracene	67	< 67 U
218-01-9	Chrysene	67	< 67 U
50-32-8	Benzo(a)pyrene	67	< 67 U
193-39-5	Indeno(1,2,3-cd)pyrene	67	< 67 U
53-70-3	Dibenz(a,h)anthracene	67	< 67 U
TOTBFA	Total Benzofluoranthenes	67	< 67 U

Reported in µg/kg (ppb)

Semivolatile Surrogate Recovery

d14-p-Terphenyl	78.8%
2-Fluorobiphenyl	65.6%

SW8270 PNA SURROGATE RECOVERY SUMMARY

Matrix: Soil

QC Report No: XL11-Landau Associates, Inc.
Project: Kaiser IA
118033.100.104

<u>Client ID</u>	<u>TER</u>	<u>FBP</u>	<u>TOT OUT</u>
MB-102413	78.8%	65.6%	0
LCS-102413	82.8%	66.0%	0
LCSD-102413	76.8%	63.6%	0
SPL-43-20131023	73.2%	62.4%	0
SPL-30-20131023	75.6%	63.2%	0
SPL-29-20131023	76.4%	68.0%	0

LCS/MB LIMITS QC LIMITS

(TER) = d14-p-Terphenyl (30-160) (30-160)
(FBP) = 2-Fluorobiphenyl (30-160) (30-160)

Prep Method: SW3546
Log Number Range: 13-23308 to 13-23310

ORGANICS ANALYSIS DATA SHEET

PNAs by SW8270D GC/MS

Page 1 of 1

Sample ID: LCS-102413

LCS/LCSD

Lab Sample ID: LCS-102413

LIMS ID: 13-23308

Matrix: Soil

Data Release Authorized: *B*

Reported: 10/25/13

QC Report No: XL11-Landau Associates, Inc.

Project: Kaiser IA

118033.100.104

Date Sampled: NA

Date Received: 10/23/13

Date Extracted LCS/LCSD: 10/24/13

Sample Amount LCS: 7.50 g-dry-wt

LCSD: 7.50 g-dry-wt

Date Analyzed LCS: 10/24/13 16:50

Final Extract Volume LCS: 0.50 mL

LCSD: 10/24/13 17:24

LCSD: 0.50 mL

Instrument/Analyst LCS: NT6/JZ

Dilution Factor LCS: 1.00

LCSD: NT6/JZ

LCSD: 1.00

GPC Cleanup: No

Alumina Cleanup: No

Silica Gel Cleanup: No

Analyte	LCS	Spike	LCS	LCS	Spike	LCSD	RPD
		Added-LCS	Recovery		Added-LCSD	Recovery	
Benzo(a)anthracene	1450	1670	86.8%	1370	1670	82.0%	5.7%
Chrysene	1410	1670	84.4%	1350	1670	80.8%	4.3%
Benzo(a)pyrene	1560	1670	93.4%	1500	1670	89.8%	3.9%
Indeno(1,2,3-cd)pyrene	1610	1670	96.4%	1510	1670	90.4%	6.4%
Dibenz(a,h)anthracene	1630	1670	97.6%	1510	1670	90.4%	7.6%
Total Benzofluoranthenes	2910	3330	87.4%	2780	3330	83.5%	4.6%

Semivolatile Surrogate Recovery

	LCS	LCSD
d14-p-Terphenyl	82.8%	76.8%
2-Fluorobiphenyl	66.0%	63.6%

Results reported in µg/kg

RPD calculated using sample concentrations per SW846.



Analytical Resources, Incorporated
Analytical Chemists and Consultants

October 28, 2013

Dave Pischer
Landau Associates, Inc.
950 Pacific Ave # 515
Tacoma, WA 98402

RE: Project: Kaiser IA
ARI Job No: XL31

Dear Dave:

Please find enclosed the original Chain-of-Custody (COC) record, sample receipt documentation, and the analytical results for the samples from the projects referenced above. Analytical Resources, Inc. (ARI) accepted six soil samples on October 24, 2013 in good condition. For further details regarding sample receipt, please refer to the enclosed Cooler Receipt Form.

The samples were analyzed for total cyanide, as requested on the COC.

The sample duplicate RPD is outside of control limits. All other QC is in control and no further corrective action was taken.

No other analytical complications were noted.

An electronic copy of this report and all associated raw data will remain on file with ARI. If you have any questions or require additional information, please feel free to contact me at your convenience.

Sincerely,
ANALYTICAL RESOURCES, INC.

Kelly Bottem
Client Services Manager
206/695-6211
kellyb@arilabs.com

Enclosures

10/14

- Seattle/Edmonds (425) 778-0907
- Tacoma (253) 926-2493
- Spokane (509) 327-9737
- Portland (503) 542-1080



Chain-of-Custody Record

Date 10/24/13
Page 1 of 1

Project Name Kaiser IA Project No. 118033.100.104

Project Location/Event Port of Tacoma

Sampler's Name DAR

Project Contact Dave Fischer Sierra Mott

Send Results To Anna Halverson, Bill Evans, Dave Fischer

Sample I.D.	Date	Time	Matrix	No. of Containers	Testing Parameters	Observations/Comments	Turnaround Time
<u>SPL-M-51-20131024</u>	<u>10/24/13</u>	<u>10:42</u>	<u>Soil</u>	<u>1</u>		<u>Allow water samples to settle, collect aliquot from clear portion</u>	<input type="checkbox"/> Standard
<u>SPL-M-52-20131024</u>		<u>10:50</u>		<u>1</u>			<input type="checkbox"/> Accelerated
<u>SPL-N-53-20131024</u>		<u>10:58</u>		<u>1</u>			<input checked="" type="checkbox"/> <u>24 hour TAT</u>
<u>SPL-N-54-20131024</u>		<u>11:25</u>		<u>1</u>		<u>NWTPH-Dx - run acid wash/silica gel cleanup</u>	
<u>SPL-M-55-20131024</u>		<u>12:45</u>		<u>1</u>		<u>run samples standardized to _____ product</u>	
<u>SPL-M-56-20131024</u>		<u>13:08</u>		<u>1</u>		<u>Analyze for EPH if no specific product identified</u>	
						<u>VOC/BTEX/VPH (soil):</u>	
						<u>non-preserved</u>	
						<u>preserved w/methanol</u>	
						<u>preserved w/sodium bisulfate</u>	
						<u>Freeze upon receipt</u>	
						<u>Dissolved metal water samples field filtered</u>	
						<u>Other _____</u>	

Special Shipment/Handling or Storage Requirements Ice

Received by	Relinquished by	Received by
Signature <u>[Signature]</u> Printed Name <u>Dave Rupert</u> Company <u>Landau Assoc</u> Date <u>10/24/13</u> Time <u>14:50</u>	Signature <u>[Signature]</u> Printed Name <u>APL</u> Company <u></u> Date <u>10/24/13</u> Time <u>14:50</u>	Signature <u>[Signature]</u> Printed Name <u>R. S. Harbor</u> Company <u></u> Date <u>10/24/13</u> Time <u>14:50</u>

Method of Shipment Courier

118033.100.104



Cooler Receipt Form

ARI Client: LAI

Project Name: Kaiser IA

COC No(s): _____ (NA)

Delivered by: Fed-Ex UPS Courier Hand Delivered Other: _____

Assigned ARI Job No: XL31

Tracking No: _____ (NA)

Preliminary Examination Phase:

Were intact, properly signed and dated custody seals attached to the outside of to cooler? YES NO
 Were custody papers included with the cooler? YES NO
 Were custody papers properly filled out (ink, signed, etc.) YES NO

Temperature of Cooler(s) (°C) (recommended 2.0-6.0 °C for chemistry)

Time: 1545

-6

If cooler temperature is out of compliance, fill out form 00070F

Temp Gun ID#: 90877952

Cooler Accepted by: _____ Date: 10/24/13 Time: 1450

Complete custody forms and attach all shipping documents

Log-In Phase:

Was a temperature blank included in the cooler? YES NO

What kind of packing material was used? ... Bubble Wrap Wet Ice Gel Packs Baggies Foam Block Paper Other: _____

Was sufficient ice used (if appropriate)? NA YES NO

Were all bottles sealed in individual plastic bags? YES NO

Did all bottles arrive in good condition (unbroken)? YES NO

Were all bottle labels complete and legible? YES NO

Did the number of containers listed on COC match with the number of containers received? YES NO

Did all bottle labels and tags agree with custody papers? YES NO

Were all bottles used correct for the requested analyses? YES NO

Do any of the analyses (bottles) require preservation? (attach preservation sheet, excluding VOCs)... NA YES NO

Were all VOC vials free of air bubbles? NA YES NO

Was sufficient amount of sample sent in each bottle? YES NO

Date VOC Trip Blank was made at ARI: NA

Was Sample Split by ARI: NA YES Date/Time: _____ Equipment: _____ Split by: _____

Samples Logged by: JM Date: 10/24/13 Time: 1550

**** Notify Project Manager of discrepancies or concerns ****

Sample ID on Bottle	Sample ID on COC	Sample ID on Bottle	Sample ID on COC

Additional Notes, Discrepancies, & Resolutions:

By: _____ Date: _____

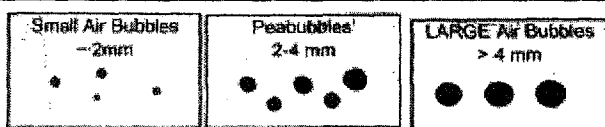

Small → "sm" (< 2 mm)
 Peabubbles → "pb" (2 to < 4 mm)
 Large → "lg" (4 to < 6 mm)
 Headspace → "hs" (> 6 mm)

Sample ID Cross Reference Report



ARI Job No: XL31
Client: Landau Associates, Inc.
Project Event: 118033.100.104
Project Name: Kaiser IA

Sample ID	ARI Lab ID	ARI LIMS ID	Matrix	Sample Date/Time	VTSR
1. SPL-M-S1-20131024	XL31A	13-23403	Soil	10/24/13 10:42	10/24/13 14:50
2. SPL-M-S2-20131024	XL31B	13-23404	Soil	10/24/13 10:50	10/24/13 14:50
3. SPL-N-S3-20131024	XL31C	13-23405	Soil	10/24/13 10:58	10/24/13 14:50
4. SPL-N-S4-20131024	XL31D	13-23406	Soil	10/24/13 11:25	10/24/13 14:50
5. SPL-M-S5-20131024	XL31E	13-23407	Soil	10/24/13 12:45	10/24/13 14:50
6. SPL-M-S6-20131024	XL31F	13-23408	Soil	10/24/13 13:08	10/24/13 14:50

SAMPLE RESULTS-CONVENTIONALS
XL31-Landau Associates, Inc.



Matrix: Soil
Data Release Authorized: *[Signature]*
Reported: 10/28/13

Project: Kaiser IA
Event: 118033.100.104
Date Sampled: 10/24/13
Date Received: 10/24/13

Client ID: SPL-M-S1-20131024
ARI ID: 13-23403 XL31A

Analyte	Date	Method	Units	RL	Sample
Total Solids	10/24/13 102413#1	SM2540G	Percent	0.01	88.52
Total Cyanide	10/25/13 102513#1	SW9010C	mg/kg	0.122	1.05

RL Analytical reporting limit
U Undetected at reported detection limit

SAMPLE RESULTS-CONVENTIONALS
XL31-Landau Associates, Inc.



Matrix: Soil
Data Release Authorized
Reported: 10/28/13

A handwritten signature in black ink, appearing to be 'JG', is written over the 'Data Release Authorized' text.

Project: Kaiser IA
Event: 118033.100.104
Date Sampled: 10/24/13
Date Received: 10/24/13

Client ID: SPL-M-S2-20131024
ARI ID: 13-23404 XL31B

Analyte	Date	Method	Units	RL	Sample
Total Solids	10/24/13 102413#1	SM2540G	Percent	0.01	88.23
Total Cyanide	10/25/13 102513#1	SW9010C	mg/kg	0.231	6.57

RL Analytical reporting limit
U Undetected at reported detection limit

SAMPLE RESULTS-CONVENTIONALS
XL31-Landau Associates, Inc.



Matrix: Soil
Data Release Authorized: *[Signature]*
Reported: 10/28/13

Project: Kaiser IA
Event: 118033.100.104
Date Sampled: 10/24/13
Date Received: 10/24/13

Client ID: SPL-N-S3-20131024
ARI ID: 13-23405 XL31C

Analyte	Date	Method	Units	RL	Sample
Total Solids	10/24/13 102413#1	SM2540G	Percent	0.01	88.96
Total Cyanide	10/25/13 102513#1	SW9010C	mg/kg	0.118	0.141

RL Analytical reporting limit
U Undetected at reported detection limit

SAMPLE RESULTS-CONVENTIONALS
XL31-Landau Associates, Inc.

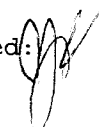

Matrix: Soil
Data Release Authorized: 
Reported: 10/28/13

Project: Kaiser IA
Event: 118033.100.104
Date Sampled: 10/24/13
Date Received: 10/24/13

Client ID: SPL-N-S4-20131024
ARI ID: 13-23406 XL31D

Analyte	Date	Method	Units	RL	Sample
Total Solids	10/24/13 102413#1	SM2540G	Percent	0.01	93.40
Total Cyanide	10/25/13 102513#1	SW9010C	mg/kg	0.107	< 0.107 U

RL Analytical reporting limit
U Undetected at reported detection limit

SAMPLE RESULTS-CONVENTIONALS
XL31-Landau Associates, Inc.

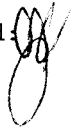

Matrix: Soil
Data Release Authorized: 
Reported: 10/28/13

Project: Kaiser IA
Event: 118033.100.104
Date Sampled: 10/24/13
Date Received: 10/24/13

Client ID: SPL-M-S5-20131024
ARI ID: 13-23407 XL31E

Analyte	Date	Method	Units	RL	Sample
Total Solids	10/24/13 102413#1	SM2540G	Percent	0.01	78.11
Total Cyanide	10/25/13 102513#1	SW9010C	mg/kg	2.77	53.7

RL Analytical reporting limit
U Undetected at reported detection limit

SAMPLE RESULTS-CONVENTIONALS
XL31-Landau Associates, Inc.

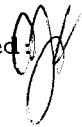

Matrix: Soil
Data Release Authorized: 
Reported: 10/28/13

Project: Kaiser IA
Event: 118033.100.104
Date Sampled: 10/24/13
Date Received: 10/24/13

Client ID: SPL-M-S6-20131024
ARI ID: 13-23408 XL31F

Analyte	Date	Method	Units	RL	Sample
Total Solids	10/24/13 102413#1	SM2540G	Percent	0.01	91.64
Total Cyanide	10/25/13 102513#1	SW9010C	mg/kg	0.112	< 0.112 U

RL Analytical reporting limit
U Undetected at reported detection limit

METHOD BLANK RESULTS-CONVENTIONALS
XL31-Landau Associates, Inc.

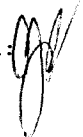

Matrix: Soil
Data Release Authorized: 
Reported: 10/28/13

Project: Kaiser IA
Event: 118033.100.104
Date Sampled: NA
Date Received: NA

Analyte	Date	Units	Blank	QC ID
Total Solids	10/24/13	Percent	< 0.01 U	ICB
Total Cyanide	10/25/13	mg/kg	< 0.050 U	PREP

STANDARD REFERENCE RESULTS-CONVENTIONALS
XL31-Landau Associates, Inc.



Matrix: Soil
Data Release Authorized: 
Reported: 10/28/13

Project: Kaiser IA
Event: 118033.100.104
Date Sampled: NA
Date Received: NA

Analyte/SRM ID	Date	Units	SRM	True Value	Recovery
Total Cyanide ERA 220811	10/25/13	mg/kg	27.0	28.1	96.1%

REPLICATE RESULTS-CONVENTIONALS
XL31-Landau Associates, Inc.



Matrix: Soil
Data Release Authorized: 
Reported: 10/28/13

Project: Kaiser IA
Event: 118033.100.104
Date Sampled: 10/24/13
Date Received: 10/24/13

Analyte	Date	Units	Sample	Replicate(s)	RPD/RSD
ARI ID: XL31A Client ID: SPL-M-S1-20131024					
Total Solids	10/24/13	Percent	88.52	88.95	0.5%
Total Cyanide	10/25/13	mg/kg	1.05	1.63	43.3%

MS/MSD RESULTS-CONVENTIONALS
XL31-Landau Associates, Inc.



Matrix: Soil
Data Release Authorized:
Reported: 10/28/13

A handwritten signature in black ink, appearing to be 'JH', is written over the 'Data Release Authorized' and 'Reported' lines.

Project: Kaiser IA
Event: 118033.100.104
Date Sampled: 10/24/13
Date Received: 10/24/13

Analyte	Date	Units	Sample	Spike	Spike Added	Recovery
ARI ID: XL31A Client ID: SPL-M-S1-20131024						
Total Cyanide	10/25/13	mg/kg	1.05	4.16	3.66	85.0%



Analytical Resources, Incorporated
Analytical Chemists and Consultants

October 28, 2013

Dave Fischer
Landau Associates, Inc.
950 Pacific Ave # 515
Tacoma, WA 98402

RE: Project: Kaiser IA
ARI Job No: XL39

Dear Dave:

Please find enclosed the original Chain-of-Custody (COC) record, sample receipt documentation, and the analytical results for the samples from the projects referenced above. Analytical Resources, Inc. (ARI) accepted three soil samples on October 25, 2013 in good condition. For further details regarding sample receipt, please refer to the enclosed Cooler Receipt Form.

The samples were analyzed for cPAHs, as requested on the COC.

No analytical complications were noted.

An electronic copy of this report and all associated raw data will remain on file with ARI. If you have any questions or require additional information, please feel free to contact me at your convenience.

Sincerely,
ANALYTICAL RESOURCES, INC.

A handwritten signature in black ink, appearing to read "K Bottem".

Kelly Bottem
Client Services Manager
206/695-6211
kellyb@arilabs.com

Enclosures

1 of 10

XL39

- Seattle/Edmonds (425) 778-0907
- Tacoma (253) 926-2493
- Spokane (509) 327-9737
- Portland (503) 542-1080



Date 10/25/2013
 Page 1 of 1

Chain-of-Custody Record

Project Name Kaiser IA Project No. 118033.100.104

Project Location/Event Kaiser, Port of Tacoma

Sampler's Name DAR

Project Contact David Pischer Sierra Mott

Send Results To Anne Halvorsen, Bill Evans, Dave Pischer

Sample I.D.	Date	Time	Matrix	No. of Containers	Testing Parameters	Observations/Comments
<u>SPL-45-20131025</u>	<u>10/25/13</u>	<u>10:36</u>	<u>Soil</u>	<u>1</u>	<u>X</u>	<u>X</u> Allow water samples to settle, collect aliquot from clear portion
<u>SPL-46-20131025</u>	<u>10:46</u>			<u>1</u>	<u>X</u>	
<u>SPL-47-20131025</u>	<u>10:57</u>			<u>1</u>	<u>X</u>	<u>X</u> NWTPH-Dx - run acid wash/silica gel cleanup
						<u>run samples standardized to _____ product</u>
						<u>Analyze for EPH if no specific product identified</u>
						<u>VOC/BTEX/VPH (soil):</u> <u>non-preserved</u> <u>preserved w/methanol</u> <u>preserved w/sodium bisulfate</u> <u>Freeze upon receipt</u>
						<u>Dissolved metal water samples field filtered</u>
						<u>Other</u>

Turnaround Time
 Standard
 Accelerated
 1-2 Day TAT

Special Shipment/Handling or Storage Requirements on ice Method of Shipment Carrier

Relinquished by	Received by	Relinquished by	Received by
Signature: <u>David Rupert</u> Printed Name: <u>David Rupert</u> Company: <u>Landau Assoc.</u> Date: <u>10/25/13</u> Time: <u>13:50</u>	Signature: <u>[Signature]</u> Printed Name: <u>[Name]</u> Company: <u>[Company]</u> Date: <u>10/25/13</u> Time: <u>1350</u>	Signature: _____ Printed Name: _____ Company: _____ Date: _____ Time: _____	Signature: _____ Printed Name: _____ Company: _____ Date: _____ Time: _____

XL 39 : 000002



Cooler Receipt Form

ARI Client: Landau

Project Name: Kaiser IA

COC No(s): _____ NA

Delivered by: Fed-Ex UPS Courier Hand Delivered Other: _____

Assigned ARI Job No: xL39

Tracking No. _____ NA

Preliminary Examination Phase:

- Were intact, properly signed and dated custody seals attached to the outside of to cooler? YES NO
- Were custody papers included with the cooler? YES NO
- Were custody papers properly filled out (ink, signed, etc.) YES NO

Temperature of Cooler(s) (°C) (recommended 2.0-6.0 °C for chemistry)
Time: 1435 2.9

If cooler temperature is out of compliance fill out form 00070F

Temp Gun ID# 9087795

Cooler Accepted by: AV Date: 10/25/13 Time: 1350

Complete custody forms and attach all shipping documents

Log-In Phase:

- Was a temperature blank included in the cooler? YES NO
- What kind of packing material was used? ... Bubble Wrap Wet Ice Gel Packs Baggies Foam Block Paper Other: _____
- Was sufficient ice used (if appropriate)? NA YES NO
- Were all bottles sealed in individual plastic bags? YES NO
- Did all bottles arrive in good condition (unbroken)? YES NO
- Were all bottle labels complete and legible? YES NO
- Did the number of containers listed on COC match with the number of containers received? YES NO
- Did all bottle labels and tags agree with custody papers? YES NO
- Were all bottles used correct for the requested analyses? YES NO
- Do any of the analyses (bottles) require preservation? (attach preservation sheet, excluding VOCs)... NA YES NO
- Were all VOC vials free of air bubbles? NA YES NO
- Was sufficient amount of sample sent in each bottle? YES NO
- Date VOC Trip Blank was made at ARI... NA _____
- Was Sample Split by ARI: NA YES Date/Time: _____ Equipment: _____ Split by: _____

Samples Logged by: JS Date: 10-25-13 Time: 1530

**** Notify Project Manager of discrepancies or concerns ****

Sample ID on Bottle	Sample ID on COC	Sample ID on Bottle	Sample ID on COC

Additional Notes, Discrepancies, & Resolutions:

By: _____ Date: _____

Small Air Bubbles ~2mm 	Peabubbles 2-4 mm 	LARGE Air Bubbles > 4 mm
--------------------------------------	---------------------------------	--

- Small → "sm" (< 2 mm)
- Peabubbles → "pb" (2 to < 4 mm)
- Large → "lg" (4 to < 6 mm)
- Headspace → "hs" (> 6 mm)

Sample ID Cross Reference Report



ARI Job No: XL39
Client: Landau Associates, Inc.
Project Event: 118033.100.104
Project Name: Kaiser IA

Sample ID	ARI Lab ID	ARI LIMS ID	Matrix	Sample Date/Time	VTSR
1. SPL-45-20131025	XL39A	13-23463	Soil	10/25/13 10:36	10/25/13 13:50
2. SPL-46-20131025	XL39B	13-23464	Soil	10/25/13 10:46	10/25/13 13:50
3. SPL-47-20131025	XL39C	13-23465	Soil	10/25/13 10:57	10/25/13 13:50

ORGANICS ANALYSIS DATA SHEET

PNAs by SW8270D GC/MS

Page 1 of 1

Sample ID: SPL-45-20131025

SAMPLE

Lab Sample ID: XL39A

LIMS ID: 13-23463

Matrix: Soil

Data Release Authorized: *AB*

Reported: 10/28/13

QC Report No: XL39-Landau Associates, Inc.

Project: Kaiser IA

118033.100.104

Date Sampled: 10/25/13

Date Received: 10/25/13

Date Extracted: 10/25/13

Date Analyzed: 10/25/13 21:23

Instrument/Analyst: NT6/JZ

GPC Cleanup: No

Alumina: No

Silica Gel: No

Sample Amount: 11.4 g-dry-wt

Final Extract Volume: 0.5 mL

Dilution Factor: 1.00

Percent Moisture: 12.6%

CAS Number	Analyte	RL	Result
56-55-3	Benzo(a)anthracene	44	< 44 U
218-01-9	Chrysene	44	< 44 U
50-32-8	Benzo(a)pyrene	44	< 44 U
193-39-5	Indeno(1,2,3-cd)pyrene	44	< 44 U
53-70-3	Dibenz(a,h)anthracene	44	< 44 U
TOTBFA	Total Benzofluoranthenes	44	< 44 U

Reported in µg/kg (ppb)

Semivolatile Surrogate Recovery

d14-p-Terphenyl	79.6%
2-Fluorobiphenyl	70.8%

ORGANICS ANALYSIS DATA SHEET

PNAs by SW8270D GC/MS

Page 1 of 1

Sample ID: SPL-46-20131025

SAMPLE

Lab Sample ID: XL39B

LIMS ID: 13-23464

Matrix: Soil

Data Release Authorized: 

Reported: 10/28/13

QC Report No: XL39-Landau Associates, Inc.

Project: Kaiser IA

118033.100.104

Date Sampled: 10/25/13

Date Received: 10/25/13

Date Extracted: 10/25/13

Date Analyzed: 10/25/13 21:57

Instrument/Analyst: NT6/JZ

GPC Cleanup: No

Alumina: No

Silica Gel: No

Sample Amount: 11.0 g-dry-wt

Final Extract Volume: 0.5 mL

Dilution Factor: 1.00

Percent Moisture: 15.7%

CAS Number	Analyte	RL	Result
56-55-3	Benzo(a)anthracene	46	< 46 U
218-01-9	Chrysene	46	< 46 U
50-32-8	Benzo(a)pyrene	46	< 46 U
193-39-5	Indeno(1,2,3-cd)pyrene	46	< 46 U
53-70-3	Dibenz(a,h)anthracene	46	< 46 U
TOTBFA	Total Benzofluoranthenes	46	< 46 U

Reported in µg/kg (ppb)

Semivolatile Surrogate Recovery

d14-p-Terphenyl	82.4%
2-Fluorobiphenyl	70.4%

ORGANICS ANALYSIS DATA SHEET

PNAs by SW8270D GC/MS

Page 1 of 1

Sample ID: SPL-47-20131025

SAMPLE

Lab Sample ID: XL39C

LIMS ID: 13-23465

Matrix: Soil

Data Release Authorized: *[Signature]*

Reported: 10/28/13

QC Report No: XL39-Landau Associates, Inc.

Project: Kaiser IA

118033.100.104

Date Sampled: 10/25/13

Date Received: 10/25/13

Date Extracted: 10/25/13

Date Analyzed: 10/25/13 22:31

Instrument/Analyst: NT6/JZ

GPC Cleanup: No

Alumina: No

Silica Gel: No

Sample Amount: 10.6 g-dry-wt

Final Extract Volume: 0.5 mL

Dilution Factor: 1.00

Percent Moisture: 18.9%

CAS Number	Analyte	RL	Result
56-55-3	Benzo(a)anthracene	47	< 47 U
218-01-9	Chrysene	47	< 47 U
50-32-8	Benzo(a)pyrene	47	< 47 U
193-39-5	Indeno(1,2,3-cd)pyrene	47	< 47 U
53-70-3	Dibenz(a,h)anthracene	47	< 47 U
TOTBFA	Total Benzofluoranthenes	47	< 47 U

Reported in µg/kg (ppb)

Semivolatile Surrogate Recovery

d14-p-Terphenyl	78.4%
2-Fluorobiphenyl	68.8%

ORGANICS ANALYSIS DATA SHEET

PNAs by SW8270D GC/MS

Page 1 of 1

Sample ID: MB-102513

METHOD BLANK

Lab Sample ID: MB-102513

LIMS ID: 13-23463

Matrix: Soil

Data Release Authorized: *AB*

Reported: 10/28/13

QC Report No: XL39-Landau Associates, Inc.

Project: Kaiser IA

118033.100.104

Date Sampled: NA

Date Received: NA

Date Extracted: 10/25/13

Date Analyzed: 10/25/13 19:42

Instrument/Analyst: NT6/JZ

GPC Cleanup: No

Alumina: No

Silica Gel: No

Sample Amount: 7.50 g-dry-wt

Final Extract Volume: 0.5 mL

Dilution Factor: 1.00

Percent Moisture: NA

CAS Number	Analyte	RL	Result
56-55-3	Benzo(a)anthracene	67	< 67 U
218-01-9	Chrysene	67	< 67 U
50-32-8	Benzo(a)pyrene	67	< 67 U
193-39-5	Indeno(1,2,3-cd)pyrene	67	< 67 U
53-70-3	Dibenz(a,h)anthracene	67	< 67 U
TOTBFA	Total Benzofluoranthenes	67	< 67 U

Reported in µg/kg (ppb)

Semivolatile Surrogate Recovery

d14-p-Terphenyl	81.6%
2-Fluorobiphenyl	55.2%

SW8270 PNA SURROGATE RECOVERY SUMMARY

Matrix: Soil

QC Report No: XL39-Landau Associates, Inc.
Project: Kaiser IA
118033.100.104

<u>Client ID</u>	<u>TER</u>	<u>FBP</u>	<u>TOT OUT</u>
MB-102513	81.6%	55.2%	0
LCS-102513	83.2%	74.0%	0
LCSD-102513	84.0%	71.6%	0
SPL-45-20131025	79.6%	70.8%	0
SPL-46-20131025	82.4%	70.4%	0
SPL-47-20131025	78.4%	68.8%	0

LCS/MB LIMITS QC LIMITS

(TER) = d14-p-Terphenyl (30-160) (30-160)
(FBP) = 2-Fluorobiphenyl (30-160) (30-160)

Prep Method: SW3546
Log Number Range: 13-23463 to 13-23465

ORGANICS ANALYSIS DATA SHEET

PNAs by SW8270D GC/MS

Page 1 of 1

Sample ID: LCS-102513

LCS/LCSD

Lab Sample ID: LCS-102513

LIMS ID: 13-23463

Matrix: Soil

Data Release Authorized: 

Reported: 10/28/13

QC Report No: XL39-Landau Associates, Inc.

Project: Kaiser IA

118033.100.104

Date Sampled: NA

Date Received: 10/25/13

Date Extracted LCS/LCSD: 10/25/13

Sample Amount LCS: 7.50 g-dry-wt

LCSD: 7.50 g-dry-wt

Date Analyzed LCS: 10/25/13 20:16

Final Extract Volume LCS: 0.50 mL

LCSD: 10/25/13 20:49

LCSD: 0.50 mL

Instrument/Analyst LCS: NT6/JZ

Dilution Factor LCS: 1.00

LCSD: NT6/JZ

LCSD: 1.00

GPC Cleanup: No

Alumina Cleanup: No

Silica Gel Cleanup: No

Analyte	Spike		LCS		Spike		LCSD	
	LCS	Added-LCS	Recovery	LCSD	Added-LCSD	Recovery	RPD	
Benzo(a)anthracene	1500	1670	89.8%	1500	1670	89.8%	0.0%	
Chrysene	1450	1670	86.8%	1460	1670	87.4%	0.7%	
Benzo(a)pyrene	1590	1670	95.2%	1610	1670	96.4%	1.2%	
Indeno(1,2,3-cd)pyrene	1560	1670	93.4%	1600	1670	95.8%	2.5%	
Dibenz(a,h)anthracene	1600	1670	95.8%	1650	1670	98.8%	3.1%	
Total Benzofluoranthenes	2910	3330	87.4%	2980	3330	89.5%	2.4%	

Semivolatile Surrogate Recovery

	LCS	LCSD
d14-p-Terphenyl	83.2%	84.0%
2-Fluorobiphenyl	74.0%	71.6%

Results reported in µg/kg

RPD calculated using sample concentrations per SW846.



Analytical Resources, Incorporated
Analytical Chemists and Consultants

October 29, 2013

Dave Fischer
Landau Associates, Inc.
950 Pacific Ave # 515
Tacoma, WA 98402

RE: Project: Kaiser IA, 118033.100.104
ARI Job No: XL49

Dear Dave:

Please find enclosed the original Chain-of-Custody record (COC), sample receipt documentation, and analytical results for samples from the projects referenced above. Analytical Resources, Inc. (ARI) accepted three soil samples on October 28, 2013 in good condition. For further details regarding sample receipt, please refer to the enclosed Cooler Receipt Form.

The samples were analyzed for cPAHs, as requested on the COC.

No analytical complications were noted.

An electronic copy of this report and all associated raw data will remain on file with ARI. If you have any questions or require additional information, please feel free to contact me at your convenience.

Sincerely,
ANALYTICAL RESOURCES, INC.

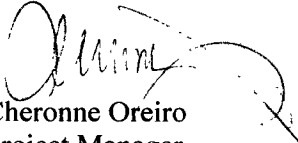

Cheronne Oreiro
Project Manager

-For-
Kelly Bottem
Client Services Manager
206/695-6211
kellyb@arilabs.com

Enclosures

1 of 10

- Seattle/Edmonds (425) 778-0907
- Tacoma (253) 926-2493
- Spokane (509) 327-9737
- Portland (503) 542-1080



Date 10/28/13
Page 1 of 1

Chain-of-Custody Record

Project Name Kaiser IA Project No. 113033.100.104

Project Location/Event Kaiser, Port of Tacoma

Sampler's Name DAR

Project Contact DAVE FISCHER

Send Results To Anna-Holmosen, Bill Evans, Dave Fischer

3555 Stone, Sierra Mott

Sample I.D.	Date	Time	Matrix	No. of Containers	Testing Parameters	Observations/Comments
<u>SPL-44-20131028</u>	<u>10/23/13</u>	<u>10:05</u>	<u>Soil</u>	<u>1</u>	<u>X</u>	<u>Allow water samples to settle, collect aliquot from clear portion</u>
<u>SPL-48-20131028</u>	<u>10:16</u>			<u>1</u>	<u>X</u>	
<u>SPL-38-20131028</u>	<u>10:31</u>			<u>1</u>	<u>X</u>	<u>NWTPH-Dx - run acid wash/silica gel cleanup</u>
						<u>run samples standardized to _____ product</u>
						<u>Analyze for EPH if no specific product identified</u>
						<u>VOC/BTEX/VPH (soil):</u>
						<u>non-preserved</u>
						<u>preserved w/methanol</u>
						<u>preserved w/sodium bisulfate</u>
						<u>Freeze upon receipt</u>
						<u>Dissolved metal water samples field filtered</u>
						<u>Other _____</u>

Turnaround Time
 Standard
 Accelerated
 1-2 Day TAT

Method of Shipment Courier

Relinquished by	Received by
Signature <u>[Signature]</u> Printed Name <u>David Rupert</u> Company <u>Landau Assoc</u> Date <u>10/28/13</u> Time <u>1405</u>	Signature <u>[Signature]</u> Printed Name <u>Rich Hecker</u> Company <u>ARL</u> Date <u>10/28/13</u> Time <u>1405</u>

Special Shipment/Handling or Storage Requirements ON ICE

Received by [Signature]
 Signature _____
 Printed Name _____
 Company _____
 Date _____ Time _____

XL 40 : 00002



Cooler Receipt Form

ARI Client: LA

Project Name: Pariser IA

COC No(s) _____ NA

Delivered by: Fed-Ex UPS Courier Hand Delivered Other: _____

Assigned ARI Job No: XL49

Tracking No. _____ NA

Preliminary Examination Phase:

Were intact, properly signed and dated custody seals attached to the outside of to cooler? YES NO

Were custody papers included with the cooler? YES NO

Were custody papers properly filled out (ink, signed, etc) YES NO

Temperature of Cooler(s) (°C) (recommended 2 0-6.0 °C for chemistry)

Time: 1600

If cooler temperature is out of compliance fill out form 00070F

Temp Gun ID#: 90877952 ^{1.3}

Cooler Accepted by: [Signature] Date: 10/28/13 Time: 1405

Complete custody forms and attach all shipping documents

Log-In Phase:

Was a temperature blank included in the cooler? YES NO

What kind of packing material was used? ... Bubble Wrap Wet Ice Gel Packs Baggies Foam Block Paper Other: _____

Was sufficient ice used (if appropriate)? NA YES NO

Were all bottles sealed in individual plastic bags? YES NO

Did all bottles arrive in good condition (unbroken)? YES NO

Were all bottle labels complete and legible? YES NO

Did the number of containers listed on COC match with the number of containers received? YES NO

Did all bottle labels and tags agree with custody papers? YES NO

Were all bottles used correct for the requested analyses? YES NO

Do any of the analyses (bottles) require preservation? (attach preservation sheet, excluding VOCs) NA YES NO

Were all VOC vials free of air bubbles? NA YES NO

Was sufficient amount of sample sent in each bottle? YES NO

Date VOC Trip Blank was made at ARI NA

Was Sample Split by ARI: NA YES Date/Time _____ Equipment: _____ Split by: _____

Samples Logged by: TJ Date: 10-28-13 Time: 1615

**** Notify Project Manager of discrepancies or concerns ****

Sample ID on Bottle	Sample ID on COC	Sample ID on Bottle	Sample ID on COC

Additional Notes, Discrepancies, & Resolutions:

By: _____ Date: _____

 Small Air Bubbles ~2mm	 Peabubbles 2-4 mm	 LARGE Air Bubbles > 4 mm	Small → "sm" (< 2 mm)
			Peabubbles → "pb" (2 to < 4 mm)
			Large → "lg" (4 to < 6 mm)
			Headspace → "hs" (> 6 mm)

Sample ID Cross Reference Report



ARI Job No: XL49
Client: Landau Associates, Inc.
Project Event: 118033.100.104
Project Name: Kaiser IA

Sample ID	ARI Lab ID	ARI LIMS ID	Matrix	Sample Date/Time	VTSR
1. SPL-44-20131028	XL49A	13-23488	Soil	10/28/13 10:05	10/28/13 14:05
2. SPL-48-20131028	XL49B	13-23489	Soil	10/28/13 10:16	10/28/13 14:05
3. SPL-38-20131028	XL49C	13-23490	Soil	10/28/13 10:31	10/28/13 14:05

ORGANICS ANALYSIS DATA SHEET

PNAs by SW8270D GC/MS

Page 1 of 1

Sample ID: SPL-44-20131028

SAMPLE

Lab Sample ID: XL49A

LIMS ID: 13-23488

Matrix: Soil

Data Release Authorized: 

Reported: 10/29/13

QC Report No: XL49-Landau Associates, Inc.

Project: Kaiser IA

118033.100.104

Date Sampled: 10/28/13

Date Received: 10/28/13

Date Extracted: 10/28/13

Date Analyzed: 10/29/13 10:58

Instrument/Analyst: NT6/JZ

GPC Cleanup: No

Alumina: No

Silica Gel: No

Sample Amount: 11.4 g-dry-wt

Final Extract Volume: 0.5 mL

Dilution Factor: 1.00

Percent Moisture: 12.2%

CAS Number	Analyte	RL	Result
56-55-3	Benzo(a)anthracene	44	< 44 U
218-01-9	Chrysene	44	< 44 U
50-32-8	Benzo(a)pyrene	44	< 44 U
193-39-5	Indeno(1,2,3-cd)pyrene	44	< 44 U
53-70-3	Dibenz(a,h)anthracene	44	< 44 U
TOTBFA	Total Benzofluoranthenes	44	< 44 U

Reported in µg/kg (ppb)

Semivolatile Surrogate Recovery

d14-p-Terphenyl	66.8%
2-Fluorobiphenyl	56.8%

ORGANICS ANALYSIS DATA SHEET

PNA's by SW8270D GC/MS

Page 1 of 1

Sample ID: SPL-48-20131028

SAMPLE

Lab Sample ID: XL49B

LIMS ID: 13-23489

Matrix: Soil

Data Release Authorized: *AS*

Reported: 10/29/13

QC Report No: XL49-Landau Associates, Inc.

Project: Kaiser IA

118033.100.104

Date Sampled: 10/28/13

Date Received: 10/28/13

Date Extracted: 10/28/13

Date Analyzed: 10/29/13 11:33

Instrument/Analyst: NT6/JZ

GPC Cleanup: No

Alumina: No

Silica Gel: No

Sample Amount: 10.8 g-dry-wt

Final Extract Volume: 0.5 mL

Dilution Factor: 1.00

Percent Moisture: 16.7%

CAS Number	Analyte	RL	Result
56-55-3	Benzo (a) anthracene	46	47
218-01-9	Chrysene	46	76
50-32-8	Benzo (a) pyrene	46	51
193-39-5	Indeno (1,2,3-cd) pyrene	46	73
53-70-3	Dibenz (a,h) anthracene	46	< 46 U
TOTBFA	Total Benzofluoranthenes	46	98

Reported in µg/kg (ppb)

Semivolatile Surrogate Recovery

d14-p-Terphenyl	69.6%
2-Fluorobiphenyl	64.4%

ORGANICS ANALYSIS DATA SHEET

PNAs by SW8270D GC/MS

Page 1 of 1

Sample ID: SPL-38-20131028

SAMPLE

Lab Sample ID: XL49C

LIMS ID: 13-23490

Matrix: Soil

Data Release Authorized: 

Reported: 10/29/13

QC Report No: XL49-Landau Associates, Inc.

Project: Kaiser IA

118033.100.104

Date Sampled: 10/28/13

Date Received: 10/28/13

Date Extracted: 10/28/13

Date Analyzed: 10/29/13 12:07

Instrument/Analyst: NT6/JZ

GPC Cleanup: No

Alumina: No

Silica Gel: No

Sample Amount: 12.0 g-dry-wt

Final Extract Volume: 0.5 mL

Dilution Factor: 1.00

Percent Moisture: 8.1%

CAS Number	Analyte	RL	Result
56-55-3	Benzo(a)anthracene	42	< 42 U
218-01-9	Chrysene	42	< 42 U
50-32-8	Benzo(a)pyrene	42	< 42 U
193-39-5	Indeno(1,2,3-cd)pyrene	42	< 42 U
53-70-3	Dibenz(a,h)anthracene	42	< 42 U
TOTBFA	Total Benzofluoranthenes	42	< 42 U

Reported in µg/kg (ppb)

Semivolatile Surrogate Recovery

d14-p-Terphenyl	70.8%
2-Fluorobiphenyl	58.0%

SW8270 PNA SURROGATE RECOVERY SUMMARY

Matrix: Soil

QC Report No: XL49-Landau Associates, Inc.
Project: Kaiser IA
118033.100.104

<u>Client ID</u>	<u>TER</u>	<u>FBP</u>	<u>TOT OUT</u>
MB-102813	74.0%	56.8%	0
LCS-102813	82.4%	64.8%	0
LCSD-102813	82.4%	67.2%	0
SPL-44-20131028	66.8%	56.8%	0
SPL-48-20131028	69.6%	64.4%	0
SPL-38-20131028	70.8%	58.0%	0

LCS/MB LIMITS QC LIMITS

(TER) = d14-p-Terphenyl (30-160) (30-160)
(FBP) = 2-Fluorobiphenyl (30-160) (30-160)

Prep Method: SW3546
Log Number Range: 13-23488 to 13-23490

ORGANICS ANALYSIS DATA SHEET

PNAs by SW8270D GC/MS

Page 1 of 1

Sample ID: LCS-102813

LCS/LCSD

Lab Sample ID: LCS-102813

LIMS ID: 13-23488

Matrix: Soil

Data Release Authorized: *[Signature]*

Reported: 10/29/13

QC Report No: XL49-Landau Associates, Inc.

Project: Kaiser IA

118033.100.104

Date Sampled: NA

Date Received: 10/28/13

Date Extracted LCS/LCSD: 10/28/13

Sample Amount LCS: 7.50 g-dry-wt

LCSD: 7.50 g-dry-wt

Date Analyzed LCS: 10/29/13 09:51

Final Extract Volume LCS: 0.50 mL

LCSD: 10/29/13 10:25

LCSD: 0.50 mL

Instrument/Analyst LCS: NT6/JZ

Dilution Factor LCS: 1.00

LCSD: NT6/JZ

LCSD: 1.00

GPC Cleanup: No

Alumina Cleanup: No

Silica Gel Cleanup: No

Analyte	LCS	Spike		LCS Recovery	LCS	Spike		RPD
		Added-LCS	Recovery			Added-LCSD	Recovery	
Benzo(a)anthracene	1480	1670	88.6%	1500	1670	89.8%	1.3%	
Chrysene	1450	1670	86.8%	1460	1670	87.4%	0.7%	
Benzo(a)pyrene	1600	1670	95.8%	1640	1670	98.2%	2.5%	
Indeno(1,2,3-cd)pyrene	1530	1670	91.6%	1540	1670	92.2%	0.7%	
Dibenz(a,h)anthracene	1570	1670	94.0%	1570	1670	94.0%	0.0%	
Total Benzofluoranthenes	3010	3330	90.4%	3070	3330	92.2%	2.0%	

Semivolatile Surrogate Recovery

	LCS	LCSD
d14-p-Terphenyl	82.4%	82.4%
2-Fluorobiphenyl	64.8%	67.2%

Results reported in µg/kg

RPD calculated using sample concentrations per SW846.

ORGANICS ANALYSIS DATA SHEET

PNAs by SW8270D GC/MS

Page 1 of 1

Sample ID: MB-102813

METHOD BLANK

Lab Sample ID: MB-102813

LIMS ID: 13-23488

Matrix: Soil

Data Release Authorized: 

Reported: 10/29/13

QC Report No: XL49-Landau Associates, Inc.

Project: Kaiser IA

118033.100.104

Date Sampled: NA

Date Received: NA

Date Extracted: 10/28/13

Date Analyzed: 10/29/13 09:17

Instrument/Analyst: NT6/JZ

GPC Cleanup: No

Alumina: No

Silica Gel: No

Sample Amount: 7.50 g-dry-wt

Final Extract Volume: 0.5 mL

Dilution Factor: 1.00

Percent Moisture: NA

CAS Number	Analyte	RL	Result
56-55-3	Benzo(a)anthracene	67	< 67 U
218-01-9	Chrysene	67	< 67 U
50-32-8	Benzo(a)pyrene	67	< 67 U
193-39-5	Indeno(1,2,3-cd)pyrene	67	< 67 U
53-70-3	Dibenz(a,h)anthracene	67	< 67 U
TOTBFA	Total Benzofluoranthenes	67	< 67 U

Reported in µg/kg (ppb)

Semivolatile Surrogate Recovery

d14-p-Terphenyl	74.0%
2-Fluorobiphenyl	56.8%



Analytical Resources, Incorporated
Analytical Chemists and Consultants

October 31, 2013

Dave Fischer
Landau Associates, Inc.
950 Pacific Ave # 515
Tacoma, WA 98402

RE: Project: Kaiser IA, 118033.100.104
ARI Job No: XL63

Dear Dave:

Please find enclosed the original Chain-of-Custody record (COC), sample receipt documentation, and analytical results for samples from the projects referenced above. Analytical Resources, Inc. (ARI) accepted five soil samples on October 29, 2013 in good condition. For further details regarding sample receipt, please refer to the enclosed Cooler Receipt Form.

The samples were analyzed for cPAHs, as requested on the COC.

No analytical complications were noted.

An electronic copy of this report and all associated raw data will remain on file with ARI. If you have any questions or require additional information, please feel free to contact me at your convenience.

Sincerely,
ANALYTICAL RESOURCES, INC.

A handwritten signature in black ink, appearing to read "Kelly Bottem".

Kelly Bottem
Client Services Manager
206/695-6211
kellyb@arilabs.com

Enclosures

1 OF 12

- Seattle/Edmonds (425) 778-0907
- Tacoma (253) 926-2493
- Spokane (509) 327-9737
- Portland (503) 542-1080



XL63

Date 10/29/13
Page 1 of 1

Chain-of-Custody Record

Project Name Kaiser I.A Project No. 118633.100.104

Project Location/Event Kaiser, Port of Tacoma

Sampler's Name DAR

Project Contact Dave Rischer

Send Results To Jess Stone, Sierra Mott, Anne Anderson, Bill Evans, Dave Rischer

Sample I.D.	Date	Time	Matrix	No. of Containers	Testing Parameters	Observations/Comments	Turnaround Time
SPL-37-20131029	10/29/13	10:14	Soil	1		X Allow water samples to settle, collect aliquot from clear portion	<input type="checkbox"/> Standard <input type="checkbox"/> Accelerated <input checked="" type="checkbox"/> 1-2 Day TAT
SPL-49-20131029	{	10:41	Soil	1			
SPL-50-20131029		10:51	Soil	1		X NWTPH-Dx - run acid wash/silica gel cleanup	
SPL-51-20131029		11:08	Soil	1			
SPL-52-20131029		11:18	Soil	1			
						run samples standardized to _____ product	
						Analyze for EPH if no specific product identified	
						VOC/BTEX/VPH (soil): non-preserved preserved w/methanol preserved w/sodium bisulfate Freeze upon receipt	
						Dissolved metal water samples field filtered	
						Other _____	

Method of Shipment Carrier

Relinquished by	Received by	Received by
Signature <u>[Signature]</u> Printed Name <u>Dave Rupert</u> Company <u>Landau Assoc</u> Date <u>10/29/13</u> Time <u>1400</u>	Signature <u>[Signature]</u> Printed Name <u>Rick Hudson</u> Company <u>ARI</u> Date <u>10/29/13</u> Time <u>1900</u>	Signature _____ Printed Name _____ Company _____ Date _____ Time _____

XL00 : 000002



Cooler Receipt Form

ARI Client: LAI

Project Name: Kaiser IA

COC No(s): _____ (NA)

Delivered by: Fed-Ex DPS Courier Hand Delivered Other: _____

Assigned ARI Job No: XL63

Tracking No: _____ (NA)

Preliminary Examination Phase:

Were intact, properly signed and dated custody seals attached to the outside of to cooler? YES NO
 Were custody papers included with the cooler? YES NO
 Were custody papers properly filled out (ink, signed, etc.) YES NO
 Temperature of Cooler(s) (°C) (recommended 2 0-6.0 °C for chemistry)
 Time: 1530 3.2

If cooler temperature is out of compliance fill out form 00070F
 Temp Gun ID#: 9CE77952

Cooler Accepted by: _____ Date: 10/29/13 Time: 1400

Complete custody forms and attach all shipping documents

Log-In Phase:

Was a temperature blank included in the cooler? YES NO AV
 What kind of packing material was used? ... Bubble Wrap Wet Ice Gel Packs Baggies Foam Block Paper Other: _____
 Was sufficient ice used (if appropriate)? NA YES NO
 Were all bottles sealed in individual plastic bags? YES NO
 Did all bottles arrive in good condition (unbroken)? YES NO
 Were all bottle labels complete and legible? YES NO
 Did the number of containers listed on COC match with the number of containers received? YES NO
 Did all bottle labels and tags agree with custody papers? YES NO
 Were all bottles used correct for the requested analyses? YES NO
 Do any of the analyses (bottles) require preservation? (attach preservation sheet, excluding VOCs)... NA YES NO
 Were all VOC vials free of air bubbles? NA YES NO
 Was sufficient amount of sample sent in each bottle? YES NO
 Date VOC Trip Blank was made at ARI... NA
 Was Sample Split by ARI NA YES Date/Time: _____ Equipment: _____ Split by: _____

Samples Logged by: AV Date: 10/29/13 Time: 1550

**** Notify Project Manager of discrepancies or concerns ****

Sample ID on Bottle	Sample ID on COC	Sample ID on Bottle	Sample ID on COC

Additional Notes, Discrepancies, & Resolutions:

By: _____ Date: _____

<p>Small Air Bubbles -2mm</p>	<p>Peabubbles 2-4 mm</p>	<p>LARGE Air Bubbles > 4 mm</p>	<p>Small → "sm" (< 2 mm)</p> <p>Peabubbles → "pb" (2 to < 4 mm)</p> <p>Large → "lg" (4 to < 6 mm)</p> <p>Headspace → "hs" (> 6 mm)</p>
-----------------------------------	------------------------------	--	--

Sample ID Cross Reference Report



ARI Job No: XL63
Client: Landau Associates, Inc.
Project Event: 118033.100.104
Project Name: Kaiser IA

Sample ID	ARI Lab ID	ARI LIMS ID	Matrix	Sample Date/Time	VTSR
1. SPL-37-20131029	XL63A	13-23590	Soil	10/29/13 10:14	10/29/13 14:00
2. SPL-49-20131029	XL63B	13-23591	Soil	10/29/13 10:41	10/29/13 14:00
3. SPL-50-20131029	XL63C	13-23592	Soil	10/29/13 10:51	10/29/13 14:00
4. SPL-51-20131029	XL63D	13-23593	Soil	10/29/13 11:08	10/29/13 14:00
5. SPL-52-20131029	XL63E	13-23594	Soil	10/29/13 11:18	10/29/13 14:00

ORGANICS ANALYSIS DATA SHEET

PNAs by SW8270D GC/MS

Page 1 of 1

Sample ID: SPL-37-20131029

SAMPLE

Lab Sample ID: XL63A

LIMS ID: 13-23590

Matrix: Soil

Data Release Authorized: 

Reported: 10/31/13

QC Report No: XL63-Landau Associates, Inc.

Project: Kaiser IA

118033.100.104

Date Sampled: 10/29/13

Date Received: 10/29/13

Date Extracted: 10/30/13

Date Analyzed: 10/30/13 19:23

Instrument/Analyst: NT6/JZ

GPC Cleanup: No

Alumina: No

Silica Gel: No

Sample Amount: 7.72 g-dry-wt

Final Extract Volume: 0.5 mL

Dilution Factor: 1.00

Percent Moisture: 36.0%

CAS Number	Analyte	RL	Result
56-55-3	Benzo(a)anthracene	65	< 65 U
218-01-9	Chrysene	65	< 65 U
50-32-8	Benzo(a)pyrene	65	< 65 U
193-39-5	Indeno(1,2,3-cd)pyrene	65	< 65 U
53-70-3	Dibenz(a,h)anthracene	65	< 65 U
TOTBFA	Total Benzofluoranthenes	65	< 65 U

Reported in µg/kg (ppb)

Semivolatile Surrogate Recovery

d14-p-Terphenyl	42.8%
2-Fluorobiphenyl	50.4%

ORGANICS ANALYSIS DATA SHEET

PNAs by SW8270D GC/MS

Page 1 of 1

Sample ID: SPL-49-20131029

SAMPLE

Lab Sample ID: XL63B

LIMS ID: 13-23591

Matrix: Soil

Data Release Authorized: 

Reported: 10/31/13

QC Report No: XL63-Landau Associates, Inc.

Project: Kaiser IA

118033.100.104

Date Sampled: 10/29/13

Date Received: 10/29/13

Date Extracted: 10/30/13

Date Analyzed: 10/30/13 19:57

Instrument/Analyst: NT6/JZ

GPC Cleanup: No

Alumina: No

Silica Gel: No

Sample Amount: 7.57 g-dry-wt

Final Extract Volume: 0.5 mL

Dilution Factor: 1.00

Percent Moisture: 5.9%

CAS Number	Analyte	RL	Result
56-55-3	Benzo(a)anthracene	66	< 66 U
218-01-9	Chrysene	66	< 66 U
50-32-8	Benzo(a)pyrene	66	< 66 U
193-39-5	Indeno(1,2,3-cd)pyrene	66	< 66 U
53-70-3	Dibenz(a,h)anthracene	66	< 66 U
TOTBFA	Total Benzofluoranthenes	66	< 66 U

Reported in µg/kg (ppb)

Semivolatile Surrogate Recovery

d14-p-Terphenyl	75.6%
2-Fluorobiphenyl	70.0%

ORGANICS ANALYSIS DATA SHEET

PNAs by SW8270D GC/MS

Page 1 of 1



Sample ID: SPL-50-20131029

SAMPLE

Lab Sample ID: XL63C

LIMS ID: 13-23592

Matrix: Soil

Data Release Authorized: *AB*

Reported: 10/31/13

QC Report No: XL63-Landau Associates, Inc.

Project: Kaiser IA

118033.100.104

Date Sampled: 10/29/13

Date Received: 10/29/13

Date Extracted: 10/30/13

Date Analyzed: 10/30/13 20:31

Instrument/Analyst: NT6/JZ

GPC Cleanup: No

Alumina: No

Silica Gel: No

Sample Amount: 7.96 g-dry-wt

Final Extract Volume: 0.5 mL

Dilution Factor: 1.00

Percent Moisture: 11.7%

CAS Number	Analyte	RL	Result
56-55-3	Benzo(a)anthracene	63	< 63 U
218-01-9	Chrysene	63	< 63 U
50-32-8	Benzo(a)pyrene	63	< 63 U
193-39-5	Indeno(1,2,3-cd)pyrene	63	< 63 U
53-70-3	Dibenz(a,h)anthracene	63	< 63 U
TOTBFA	Total Benzofluoranthenes	63	< 63 U

Reported in µg/kg (ppb)

Semivolatile Surrogate Recovery

d14-p-Terphenyl	76.4%
2-Fluorobiphenyl	71.6%

ORGANICS ANALYSIS DATA SHEET

PNA's by SW8270D GC/MS

Page 1 of 1



Sample ID: SPL-51-20131029

SAMPLE

Lab Sample ID: XL63D

LIMS ID: 13-23593

Matrix: Soil

Data Release Authorized:

Reported: 10/31/13

QC Report No: XL63-Landau Associates, Inc.

Project: Kaiser IA

118033.100.104

Date Sampled: 10/29/13

Date Received: 10/29/13

Date Extracted: 10/30/13

Date Analyzed: 10/30/13 21:05

Instrument/Analyst: NT6/JZ

GPC Cleanup: No

Alumina: No

Silica Gel: No

Sample Amount: 8.30 g-dry-wt

Final Extract Volume: 0.5 mL

Dilution Factor: 1.00

Percent Moisture: 8.0%

CAS Number	Analyte	RL	Result
56-55-3	Benzo(a)anthracene	60	< 60 U
218-01-9	Chrysene	60	120
50-32-8	Benzo(a)pyrene	60	66
193-39-5	Indeno(1,2,3-cd)pyrene	60	67
53-70-3	Dibenz(a,h)anthracene	60	< 60 U
TOTBFA	Total Benzofluoranthenes	60	250

Reported in µg/kg (ppb)

Semivolatile Surrogate Recovery

d14-p-Terphenyl	78.0%
2-Fluorobiphenyl	68.4%

ORGANICS ANALYSIS DATA SHEET

PNAs by SW8270D GC/MS

Page 1 of 1

Sample ID: SPL-52-20131029

SAMPLE

Lab Sample ID: XL63E

LIMS ID: 13-23594

Matrix: Soil

Data Release Authorized: *B*

Reported: 10/31/13

QC Report No: XL63-Landau Associates, Inc.

Project: Kaiser IA

118033.100.104

Date Sampled: 10/29/13

Date Received: 10/29/13

Date Extracted: 10/30/13

Date Analyzed: 10/30/13 21:38

Instrument/Analyst: NT6/JZ

GPC Cleanup: No

Alumina: No

Silica Gel: No

Sample Amount: 7.59 g-dry-wt

Final Extract Volume: 0.5 mL

Dilution Factor: 1.00

Percent Moisture: 16.0%

CAS Number	Analyte	RL	Result
56-55-3	Benzo(a)anthracene	66	< 66 U
218-01-9	Chrysene	66	< 66 U
50-32-8	Benzo(a)pyrene	66	< 66 U
193-39-5	Indeno(1,2,3-cd)pyrene	66	< 66 U
53-70-3	Dibenz(a,h)anthracene	66	< 66 U
TOTBFA	Total Benzofluoranthenes	66	< 66 U

Reported in µg/kg (ppb)

Semivolatile Surrogate Recovery

d14-p-Terphenyl	63.6%
2-Fluorobiphenyl	66.0%

ORGANICS ANALYSIS DATA SHEET

PNA's by SW8270D GC/MS

Page 1 of 1

Sample ID: MB-103013

METHOD BLANK

Lab Sample ID: MB-103013

LIMS ID: 13-23590

Matrix: Soil

Data Release Authorized:

Reported: 10/31/13

QC Report No: XL63-Landau Associates, Inc.

Project: Kaiser IA

118033.100.104

Date Sampled: NA

Date Received: NA

Date Extracted: 10/30/13

Date Analyzed: 10/30/13 17:42

Instrument/Analyst: NT6/JZ

GPC Cleanup: No

Alumina: No

Silica Gel: No

Sample Amount: 7.50 g-dry-wt

Final Extract Volume: 0.5 mL

Dilution Factor: 1.00

Percent Moisture: NA

CAS Number	Analyte	RL	Result
56-55-3	Benzo(a)anthracene	67	< 67 U
218-01-9	Chrysene	67	< 67 U
50-32-8	Benzo(a)pyrene	67	< 67 U
193-39-5	Indeno(1,2,3-cd)pyrene	67	< 67 U
53-70-3	Dibenz(a,h)anthracene	67	< 67 U
TOTBFA	Total Benzofluoranthenes	67	< 67 U

Reported in µg/kg (ppb)

Semivolatile Surrogate Recovery

d14-p-Terphenyl	79.2%
2-Fluorobiphenyl	70.8%

SW8270 PNA SURROGATE RECOVERY SUMMARY

Matrix: Soil

QC Report No: XL63-Landau Associates, Inc.
Project: Kaiser IA
118033.100.104

<u>Client ID</u>	<u>TER</u>	<u>FBP</u>	<u>TOT OUT</u>
MB-103013	79.2%	70.8%	0
LCS-103013	80.0%	72.0%	0
LCSD-103013	81.2%	70.4%	0
SPL-37-20131029	42.8%	50.4%	0
SPL-49-20131029	75.6%	70.0%	0
SPL-50-20131029	76.4%	71.6%	0
SPL-51-20131029	78.0%	68.4%	0
SPL-52-20131029	63.6%	66.0%	0

LCS/MB LIMITS QC LIMITS

(TER) = d14-p-Terphenyl (30-160) (30-160)
(FBP) = 2-Fluorobiphenyl (30-160) (30-160)

Prep Method: SW3546
Log Number Range: 13-23590 to 13-23594

ORGANICS ANALYSIS DATA SHEET

PNAs by SW8270D GC/MS

Page 1 of 1

Sample ID: LCS-103013

LCS/LCSD

Lab Sample ID: LCS-103013

LIMS ID: 13-23590

Matrix: Soil

Data Release Authorized: *AB*

Reported: 10/31/13

QC Report No: XL63-Landau Associates, Inc.

Project: Kaiser IA

118033.100.104

Date Sampled: NA

Date Received: 10/29/13

Date Extracted LCS/LCSD: 10/30/13

Sample Amount LCS: 7.50 g-dry-wt

LCSD: 7.50 g-dry-wt

Date Analyzed LCS: 10/30/13 18:16

Final Extract Volume LCS: 0.50 mL

LCSD: 10/30/13 18:50

LCSD: 0.50 mL

Instrument/Analyst LCS: NT6/JZ

Dilution Factor LCS: 1.00

LCSD: NT6/JZ

LCSD: 1.00

GPC Cleanup: No

Alumina Cleanup: No

Silica Gel Cleanup: No

Analyte	Spike		LCS		Spike		LCSD	
	LCS	Added-LCS	Recovery	LCS	Added-LCSD	Recovery	RPD	
Benzo(a)anthracene	1310	1670	78.4%	1370	1670	82.0%	4.5%	
Chrysene	1290	1670	77.2%	1350	1670	80.8%	4.5%	
Benzo(a)pyrene	1440	1670	86.2%	1540	1670	92.2%	6.7%	
Indeno(1,2,3-cd)pyrene	1410	1670	84.4%	1510	1670	90.4%	6.8%	
Dibenz(a,h)anthracene	1440	1670	86.2%	1560	1670	93.4%	8.0%	
Total Benzofluoranthenes	2680	3330	80.5%	2870	3330	86.2%	6.8%	

Semivolatile Surrogate Recovery

	LCS	LCSD
d14-p-Terphenyl	80.0%	81.2%
2-Fluorobiphenyl	72.0%	70.4%

Results reported in µg/kg

RPD calculated using sample concentrations per SW846.



Analytical Resources, Incorporated
Analytical Chemists and Consultants

November 8, 2013

Dave Fischer
Landau Associates, Inc.
950 Pacific Ave # 515
Tacoma, WA 98402

RE: Project: Kaiser IA, 118033.100.104
ARI Job No: XM90

Dear Dave:

Please find enclosed the original Chain-of-Custody record (COC), sample receipt documentation, and analytical results for samples from the projects referenced above. Analytical Resources, Inc. (ARI) accepted seven soil samples on November 6, 2013 in good condition. For further details regarding sample receipt, please refer to the enclosed Cooler Receipt Form.

The samples were analyzed for cPAHs, as requested on the COC.

No analytical complications were noted.

An electronic copy of this report and all associated raw data will remain on file with ARI. If you have any questions or require additional information, please feel free to contact me at your convenience.

Sincerely,
ANALYTICAL RESOURCES, INC.

A handwritten signature in black ink, appearing to read "Kelly Bottem".

Kelly Bottem
Client Services Manager
206/695-6211
kellyb@arilabs.com

Enclosures

1 of 14

- Seattle/Edmonds (425) 778-0907
- Tacoma (253) 926-2493
- Spokane (509) 327-9737
- Portland (503) 542-1080



Chain-of-Custody Record

Date 11-6-2013
 Page 1 of 1

Project Name Kaiser IA Project No. 118033.10D.104

Project Location/Event Kaiser, Port of Tacoma

Sampler's Name SMM, DAR

Project Contact Dave Pischer
Jess Stone
Sierra Mott

Send Results To Ann Halvorsen, Bill Evans, Dave Pischer

Turnaround Time
 Standard
 Accelerated
 1-2 Day IAT

Sample I.D.	Date	Time	Matrix	No. of Containers	Testing Parameters	Observations/Comments	
SPL-56-20131106	11-6-13	10:49	Soil	1	<input checked="" type="checkbox"/>	X Allow water samples to settle, collect aliquot from clear portion X NWTPH-Dx - run acid wash/silica gel cleanup _____ run samples standardized to _____ product _____ Analyze for EPH if no specific product identified VOC/BTEX/VPH (soil): _____ non-preserved _____ preserved w/methanol _____ preserved w/sodium bisulfate _____ Freeze upon receipt _____ Dissolved metal water samples field filtered Other _____	
SPL-57-20131106		11:03	}	1	<input checked="" type="checkbox"/>		
SPL-58-20131106		10:45		1	<input checked="" type="checkbox"/>		
SPL-59-20131106		10:29		1	<input checked="" type="checkbox"/>		
SPL-60-20131106		10:25		1	<input checked="" type="checkbox"/>		
SPL-61-20131106		10:15		1	<input checked="" type="checkbox"/>		
SPL-62-20131106		10:56		1	<input checked="" type="checkbox"/>		
Special Shipment/Handling or Storage Requirements <u>OK ICE</u>						Method of Shipment <u>Covier</u>	
Relinquished by Signature <u>David Rupert</u> Printed Name <u>David Rupert</u> Company <u>Landau Assoc.</u> Date <u>11/6/13</u> Time <u>1325</u>		Received by Signature <u>Rich Hansen</u> Printed Name <u>AR1</u> Company _____ Date <u>11/6/13</u> Time <u>1325</u>		Relinquished by Signature _____ Printed Name _____ Company _____ Date _____ Time _____		Received by Signature _____ Printed Name _____ Company _____ Date _____ Time _____	

XM96

2000 0000



Cooler Receipt Form

ARI Client LAI
 COC No(s) _____ (NA)
 Assigned ARI Job No: KM90

Project Name: Kaisey IA
 Delivered by Fed-Ex UPS Courier Hand Delivered Other: _____
 Tracking No: _____ (NA)

Preliminary Examination Phase:

Were intact, properly signed and dated custody seals attached to the outside of to cooler? YES NO
 Were custody papers included with the cooler? YES NO
 Were custody papers properly filled out (ink, signed, etc.) YES NO
 Temperature of Cooler(s) (°C) (recommended 2.0-6.0 °C for chemistry)
 Time 1900
 If cooler temperature is out of compliance fill out form 00070F

Cooler Accepted by: [Signature] Date 11/6/13 Time: 1325 Temp Gun ID#: 90877952 5.8
Complete custody forms and attach all shipping documents

Log-In Phase:

Was a temperature blank included in the cooler? YES (NO)
 What kind of packing material was used? Bubble Wrap Wet Ice Gel Packs Baggies Foam Block Paper Other: _____
 Was sufficient ice used (if appropriate)? NA YES NO
 Were all bottles sealed in individual plastic bags? YES NO
 Did all bottles arrive in good condition (unbroken)? YES NO
 Were all bottle labels complete and legible? YES NO
 Did the number of containers listed on COC match with the number of containers received? YES NO
 Did all bottle labels and tags agree with custody papers? YES NO
 Were all bottles used correct for the requested analyses? YES NO
 Do any of the analyses (bottles) require preservation? (attach preservation sheet, excluding VOCs).. (NA) YES NO
 Were all VOC vials free of air bubbles? (NA) YES NO
 Was sufficient amount of sample sent in each bottle? YES NO
 Date VOC Trip Blank was made at ARI (NA) _____
 Was Sample Split by ARI: (NA) YES Date/Time: _____ Equipment _____ Split by: _____

Samples Logged by AV Date 11/6/13 Time 1415

**** Notify Project Manager of discrepancies or concerns ****

Sample ID on Bottle	Sample ID on COC	Sample ID on Bottle	Sample ID on COC

Additional Notes, Discrepancies, & Resolutions:

By _____ Date: _____

			Small → "sm" (< 2 mm)
			Peabubbles → "pb" (2 to < 4 mm)
			Large → "lg" (4 to < 6 mm)
			Headspace → "hs" (> 6 mm)

KM90 . 00003

Sample ID Cross Reference Report



ARI Job No: XM90
Client: Landau Associates, Inc.
Project Event: 118033.100.104
Project Name: Kaiser IA

Sample ID	ARI Lab ID	ARI LIMS ID	Matrix	Sample Date/Time	VTSR
1. SPL-56-20131106	XM90A	13-24422	Soil	11/06/13 10:49	11/06/13 13:25
2. SPL-57-20131106	XM90B	13-24423	Soil	11/06/13 11:03	11/06/13 13:25
3. SPL-58-20131106	XM90C	13-24424	Soil	11/06/13 10:45	11/06/13 13:25
4. SPL-59-20131106	XM90D	13-24425	Soil	11/06/13 10:29	11/06/13 13:25
5. SPL-60-20131106	XM90E	13-24426	Soil	11/06/13 10:25	11/06/13 13:25
6. SPL-61-20131106	XM90F	13-24427	Soil	11/06/13 10:15	11/06/13 13:25
7. SPL-62-20131106	XM90G	13-24428	Soil	11/06/13 10:55	11/06/13 13:25

ORGANICS ANALYSIS DATA SHEET

PNAs by SW8270D GC/MS

Page 1 of 1

Sample ID: SPL-56-20131106

SAMPLE

Lab Sample ID: XM90A

LIMS ID: 13-24422

Matrix: Soil

Data Release Authorized: *AS*

Reported: 11/08/13

QC Report No: XM90-Landau Associates, Inc.

Project: Kaiser IA

118033.100.104

Date Sampled: 11/06/13

Date Received: 11/06/13

Date Extracted: 11/07/13

Date Analyzed: 11/07/13 20:07

Instrument/Analyst: NT6/JZ

GPC Cleanup: No

Alumina: No

Silica Gel: No

Sample Amount: 8.39 g-dry-wt

Final Extract Volume: 0.5 mL

Dilution Factor: 1.00

Percent Moisture: 9.0%

CAS Number	Analyte	RL	Result
56-55-3	Benzo(a)anthracene	60	< 60 U
218-01-9	Chrysene	60	< 60 U
50-32-8	Benzo(a)pyrene	60	< 60 U
193-39-5	Indeno(1,2,3-cd)pyrene	60	< 60 U
53-70-3	Dibenz(a,h)anthracene	60	< 60 U
TOTBFA	Total Benzofluoranthenes	60	< 60 U

Reported in µg/kg (ppb)

Semivolatile Surrogate Recovery

d14-p-Terphenyl	70.8%
2-Fluorobiphenyl	62.4%

ORGANICS ANALYSIS DATA SHEET

PNA's by SW8270D GC/MS

Page 1 of 1

**Sample ID: SPL-57-20131106
SAMPLE**

Lab Sample ID: XM90B
LIMS ID: 13-24423
Matrix: Soil
Data Release Authorized: 
Reported: 11/08/13

QC Report No: XM90-Landau Associates, Inc.
Project: Kaiser IA
118033.100.104
Date Sampled: 11/06/13
Date Received: 11/06/13

Date Extracted: 11/07/13
Date Analyzed: 11/07/13 20:40
Instrument/Analyst: NT6/JZ
GPC Cleanup: No
Alumina: No
Silica Gel: No

Sample Amount: 7.98 g-dry-wt
Final Extract Volume: 0.5 mL
Dilution Factor: 1.00
Percent Moisture: 15.5%

CAS Number	Analyte	RL	Result
56-55-3	Benzo(a)anthracene	63	< 63 U
218-01-9	Chrysene	63	< 63 U
50-32-8	Benzo(a)pyrene	63	< 63 U
193-39-5	Indeno(1,2,3-cd)pyrene	63	< 63 U
53-70-3	Dibenz(a,h)anthracene	63	< 63 U
TOTBFA	Total Benzofluoranthenes	63	< 63 U

Reported in µg/kg (ppb)

Semivolatile Surrogate Recovery

d14-p-Terphenyl	80.8%
2-Fluorobiphenyl	63.2%

ORGANICS ANALYSIS DATA SHEET

PNAs by SW8270D GC/MS

Page 1 of 1

Sample ID: SPL-58-20131106

SAMPLE

Lab Sample ID: XM90C

LIMS ID: 13-24424

Matrix: Soil

Data Release Authorized: *AB*

Reported: 11/08/13

QC Report No: XM90-Landau Associates, Inc.

Project: Kaiser IA

118033.100.104

Date Sampled: 11/06/13

Date Received: 11/06/13

Date Extracted: 11/07/13

Date Analyzed: 11/07/13 21:14

Instrument/Analyst: NT6/JZ

GPC Cleanup: No

Alumina: No

Silica Gel: No

Sample Amount: 8.24 g-dry-wt

Final Extract Volume: 0.5 mL

Dilution Factor: 1.00

Percent Moisture: 9.9%

CAS Number	Analyte	RL	Result
56-55-3	Benzo(a)anthracene	61	< 61 U
218-01-9	Chrysene	61	90
50-32-8	Benzo(a)pyrene	61	61
193-39-5	Indeno(1,2,3-cd)pyrene	61	< 61 U
53-70-3	Dibenz(a,h)anthracene	61	< 61 U
TOTBFA	Total Benzofluoranthenes	61	120

Reported in µg/kg (ppb)

Semivolatile Surrogate Recovery

d14-p-Terphenyl	80.8%
2-Fluorobiphenyl	69.6%

ORGANICS ANALYSIS DATA SHEET

PNAs by SW8270D GC/MS

Page 1 of 1

Sample ID: SPL-59-20131106

SAMPLE

Lab Sample ID: XM90D

LIMS ID: 13-24425

Matrix: Soil

Data Release Authorized: 

Reported: 11/08/13

QC Report No: XM90-Landau Associates, Inc.

Project: Kaiser IA

118033.100.104

Date Sampled: 11/06/13

Date Received: 11/06/13

Date Extracted: 11/07/13

Date Analyzed: 11/07/13 21:48

Instrument/Analyst: NT6/JZ

GPC Cleanup: No

Alumina: No

Silica Gel: No

Sample Amount: 8.30 g-dry-wt

Final Extract Volume: 0.5 mL

Dilution Factor: 1.00

Percent Moisture: 10.5%

CAS Number	Analyte	RL	Result
56-55-3	Benzo(a)anthracene	60	< 60 U
218-01-9	Chrysene	60	74
50-32-8	Benzo(a)pyrene	60	< 60 U
193-39-5	Indeno(1,2,3-cd)pyrene	60	< 60 U
53-70-3	Dibenz(a,h)anthracene	60	< 60 U
TOTBFA	Total Benzofluoranthenes	60	110

Reported in µg/kg (ppb)

Semivolatile Surrogate Recovery

d14-p-Terphenyl	76.0%
2-Fluorobiphenyl	66.4%

ORGANICS ANALYSIS DATA SHEET

PNAs by SW8270D GC/MS

Page 1 of 1

Sample ID: SPL-60-20131106

SAMPLE

Lab Sample ID: XM90E

LIMS ID: 13-24426

Matrix: Soil

Data Release Authorized:

Reported: 11/08/13

QC Report No: XM90-Landau Associates, Inc.

Project: Kaiser IA

118033.100.104

Date Sampled: 11/06/13

Date Received: 11/06/13

Date Extracted: 11/07/13

Date Analyzed: 11/07/13 22:22

Instrument/Analyst: NT6/JZ

GPC Cleanup: No

Alumina: No

Silica Gel: No

Sample Amount: 7.88 g-dry-wt

Final Extract Volume: 0.5 mL

Dilution Factor: 1.00

Percent Moisture: 12.4%

CAS Number	Analyte	RL	Result
56-55-3	Benzo(a)anthracene	64	< 64 U
218-01-9	Chrysene	64	< 64 U
50-32-8	Benzo(a)pyrene	64	< 64 U
193-39-5	Indeno(1,2,3-cd)pyrene	64	< 64 U
53-70-3	Dibenz(a,h)anthracene	64	< 64 U
TOTBFA	Total Benzofluoranthenes	64	< 64 U

Reported in µg/kg (ppb)

Semivolatile Surrogate Recovery

d14-p-Terphenyl	81.2%
2-Fluorobiphenyl	74.4%

ORGANICS ANALYSIS DATA SHEET

PNAs by SW8270D GC/MS

Page 1 of 1

Sample ID: SPL-61-20131106

SAMPLE

Lab Sample ID: XM90F

LIMS ID: 13-24427

Matrix: Soil

Data Release Authorized: 

Reported: 11/08/13

QC Report No: XM90-Landau Associates, Inc.

Project: Kaiser IA

118033.100.104

Date Sampled: 11/06/13

Date Received: 11/06/13

Date Extracted: 11/07/13

Date Analyzed: 11/07/13 22:56

Instrument/Analyst: NT6/JZ

GPC Cleanup: No

Alumina: No

Silica Gel: No

Sample Amount: 8.43 g-dry-wt

Final Extract Volume: 0.5 mL

Dilution Factor: 1.00

Percent Moisture: 14.0%

CAS Number	Analyte	RL	Result
56-55-3	Benzo(a)anthracene	59	< 59 U
218-01-9	Chrysene	59	< 59 U
50-32-8	Benzo(a)pyrene	59	< 59 U
193-39-5	Indeno(1,2,3-cd)pyrene	59	< 59 U
53-70-3	Dibenz(a,h)anthracene	59	< 59 U
TOTBFA	Total Benzofluoranthenes	59	< 59 U

Reported in µg/kg (ppb)

Semivolatile Surrogate Recovery

d14-p-Terphenyl	75.2%
2-Fluorobiphenyl	68.0%

ORGANICS ANALYSIS DATA SHEET

PNAs by SW8270D GC/MS

Page 1 of 1

Sample ID: SPL-62-20131106

SAMPLE

Lab Sample ID: XM90G

LIMS ID: 13-24428

Matrix: Soil

Data Release Authorized: *[Signature]*

Reported: 11/08/13

QC Report No: XM90-Landau Associates, Inc.

Project: Kaiser IA

118033.100.104

Date Sampled: 11/06/13

Date Received: 11/06/13

Date Extracted: 11/07/13

Date Analyzed: 11/07/13 23:30

Instrument/Analyst: NT6/JZ

GPC Cleanup: No

Alumina: No

Silica Gel: No

Sample Amount: 7.93 g-dry-wt

Final Extract Volume: 0.5 mL

Dilution Factor: 1.00

Percent Moisture: 12.6%

CAS Number	Analyte	RL	Result
56-55-3	Benzo (a) anthracene	63	140
218-01-9	Chrysene	63	840
50-32-8	Benzo (a) pyrene	63	130
193-39-5	Indeno (1,2,3-cd) pyrene	63	190
53-70-3	Dibenz (a,h) anthracene	63	76
TOTBFA	Total Benzofluoranthenes	63	590

Reported in µg/kg (ppb)

Semivolatile Surrogate Recovery

d14-p-Terphenyl	67.2%
2-Fluorobiphenyl	61.2%

ORGANICS ANALYSIS DATA SHEET

PNAs by SW8270D GC/MS

Page 1 of 1

Sample ID: MB-110713

METHOD BLANK

Lab Sample ID: MB-110713

LIMS ID: 13-24422

Matrix: Soil

Data Release Authorized:

Reported: 11/08/13

QC Report No: XM90-Landau Associates, Inc.

Project: Kaiser IA

118033.100.104

Date Sampled: NA

Date Received: NA

Date Extracted: 11/07/13

Date Analyzed: 11/07/13 18:25

Instrument/Analyst: NT6/JZ

GPC Cleanup: No

Alumina: No

Silica Gel: No

Sample Amount: 7.50 g-dry-wt

Final Extract Volume: 0.5 mL

Dilution Factor: 1.00

Percent Moisture: NA

CAS Number	Analyte	RL	Result
56-55-3	Benzo(a)anthracene	67	< 67 U
218-01-9	Chrysene	67	< 67 U
50-32-8	Benzo(a)pyrene	67	< 67 U
193-39-5	Indeno(1,2,3-cd)pyrene	67	< 67 U
53-70-3	Dibenz(a,h)anthracene	67	< 67 U
TOTBFA	Total Benzofluoranthenes	67	< 67 U

Reported in µg/kg (ppb)

Semivolatile Surrogate Recovery

d14-p-Terphenyl	77.6%
2-Fluorobiphenyl	66.0%

SW8270 PNA SURROGATE RECOVERY SUMMARY



Matrix: Soil

QC Report No: XM90-Landau Associates, Inc.
 Project: Kaiser IA
 118033.100.104

<u>Client ID</u>	<u>TER</u>	<u>FBP</u>	<u>TOT OUT</u>
MB-110713	77.6%	66.0%	0
LCS-110713	89.2%	72.4%	0
LCSD-110713	84.4%	70.0%	0
SPL-56-20131106	70.8%	62.4%	0
SPL-57-20131106	80.8%	63.2%	0
SPL-58-20131106	80.8%	69.6%	0
SPL-59-20131106	76.0%	66.4%	0
SPL-60-20131106	81.2%	74.4%	0
SPL-61-20131106	75.2%	68.0%	0
SPL-62-20131106	67.2%	61.2%	0

LCS/MB LIMITS QC LIMITS

(TER) = d14-p-Terphenyl (30-160) (30-160)
 (FBP) = 2-Fluorobiphenyl (30-160) (30-160)

Prep Method: SW3546
 Log Number Range: 13-24422 to 13-24428

ORGANICS ANALYSIS DATA SHEET

PNAs by SW8270D GC/MS

Page 1 of 1

Sample ID: LCS-110713

LCS/LCSD

Lab Sample ID: LCS-110713

LIMS ID: 13-24422

Matrix: Soil

Data Release Authorized: *AS*

Reported: 11/08/13

QC Report No: XM90-Landau Associates, Inc.

Project: Kaiser IA

118033.100.104

Date Sampled: NA

Date Received: 11/06/13

Date Extracted LCS/LCSD: 11/07/13

Sample Amount LCS: 7.50 g-dry-wt

LCSD: 7.50 g-dry-wt

Date Analyzed LCS: 11/07/13 18:59

Final Extract Volume LCS: 0.50 mL

LCSD: 11/07/13 19:33

LCSD: 0.50 mL

Instrument/Analyst LCS: NT6/JZ

Dilution Factor LCS: 1.00

LCSD: NT6/JZ

LCSD: 1.00

GPC Cleanup: No

Alumina Cleanup: No

Silica Gel Cleanup: No

Analyte	Spike		LCS		Spike		LCSD	
	LCS	Added-LCS	Recovery	LCS	Added-LCSD	Recovery	RPD	
Benzo(a)anthracene	1450	1670	86.8%	1440	1670	86.2%	0.7%	
Chrysene	1440	1670	86.2%	1440	1670	86.2%	0.0%	
Benzo(a)pyrene	1580	1670	94.6%	1530	1670	91.6%	3.2%	
Indeno(1,2,3-cd)pyrene	1490	1670	89.2%	1460	1670	87.4%	2.0%	
Dibenz(a,h)anthracene	1550	1670	92.8%	1510	1670	90.4%	2.6%	
Total Benzofluoranthenes	3130	3330	94.0%	3030	3330	91.0%	3.2%	

Semivolatile Surrogate Recovery

	LCS	LCSD
d14-p-Terphenyl	89.2%	84.4%
2-Fluorobiphenyl	72.4%	70.0%

Results reported in µg/kg

RPD calculated using sample concentrations per SW846.



Analytical Resources, Incorporated
Analytical Chemists and Consultants

November 12, 2013

Dave Pischer
Landau Associates, Inc.
950 Pacific Ave # 515
Tacoma, WA 98402

RE: Project: Kaiser IA, 118033.100.104
ARI Job No: XN53

Dear Dave:

Please find enclosed the original Chain-of-Custody record (COC), sample receipt documentation, and analytical results for samples from the projects referenced above. Analytical Resources, Inc. (ARI) accepted eight soil samples on November 11, 2013 in good condition. For further details regarding sample receipt, please refer to the enclosed Cooler Receipt Form.

The samples were analyzed for cPAHs, as requested on the COC.

The CCAL is out of control high for all associated FORM III "Q" flagged analytes. All associated samples that contain analyte have been flagged with a "Q" qualifier.

No other analytical complications were noted.

An electronic copy of this report and all associated raw data will remain on file with ARI. If you have any questions or require additional information, please feel free to contact me at your convenience.

Sincerely,
ANALYTICAL RESOURCES, INC.

A handwritten signature in black ink, appearing to read "Kelly Böttem".

Kelly Böttem
Client Services Manager
206/695-6211
kellyb@arilabs.com

Enclosures

- Seattle/Edmonds (425) 778-0907
- Tacoma (253) 926-2493
- Spokane (509) 327-9737
- Portland (503) 542-1080



Chain-of-Custody Record

Date 11/11/13
Page 1 of 1

Project Name KAISER IA Project No. 118083.100.104

Project Location/Event KAISER, Port of Tacoma

Sampler's Name DAR

Project Contact DAVE FISCHER

Send Results To Jess Stone, Steve Mott, Anne Helmersen, Bill Evans, Dave Fischer

Sample I.D.	Date	Time	Matrix	No. of Containers	Testing Parameters	Observations/Comments
SPL-53-20131111	11/11/13	10:28	Soil	1	X	Allow water samples to settle, collect aliquot from clear portion NWTPH-DX - run acid wash/silica gel cleanup run samples standardized to _____ product Analyze for EPH if no specific product identified VOC/BTEX/VPH (soil): non-preserved _____ preserved w/methanol _____ preserved w/sodium bisulfate _____ Freeze upon receipt _____ Dissolved metal water samples field filtered _____ Other _____
SPL-54-20131111		10:39		1	X	
SPL-55-20131111		10:49		1	X	
SPL-63-20131111		11:30		1	X	
SPL-65-20131111		12:27		1	X	
SPL-66-20131111		12:15		1	X	
SPL-67-20131111		12:01		1	X	
SPL-68-20131111		11:52		1	X	

Turnaround Time
 Standard
 Accelerated
 1-2 Day TAT

Special Shipment/Handling or Storage Requirements On Ice Method of Shipment Carrier

Relinquished by	Received by	Relinquished by	Received by
Signature <u>[Signature]</u> Printed Name <u>David Rupert</u> Company <u>Landau Assoc. Inc</u> Date <u>11/11/13</u> Time <u>13:40</u>	Signature <u>[Signature]</u> Printed Name <u>ARI</u> Company _____ Date <u>11/11/13</u> Time <u>13:40</u>	Signature _____ Printed Name _____ Company _____ Date _____ Time _____	Signature _____ Printed Name _____ Company _____ Date _____ Time _____

C PHT 6270D



Cooler Receipt Form

ARI Client: LAI
COC No(s): _____ NA
Assigned ARI Job No: XN33

Project Name: Karbo IA
Delivered by: Fed-Ex UPS Courier Hand Delivered Other: _____
Tracking No: _____ NA

Preliminary Examination Phase:

Were intact, properly signed and dated custody seals attached to the outside of to cooler? YES NO
 Were custody papers included with the cooler? YES NO
 Were custody papers properly filled out (ink, signed, etc.) YES NO
 Temperature of Cooler(s) (°C) (recommended 2.0-6.0 °C for chemistry)
 Time: 1435 9.1
 If cooler temperature is out of compliance fill out form 00070F
 Temp Gun ID#: 122412224
 Cooler Accepted by: [Signature] Date: 11/1/13 Time: 1340

Complete custody forms and attach all shipping documents

Log-In Phase:

Was a temperature blank included in the cooler? YES NO
 What kind of packing material was used? ... Bubble Wrap Wet Ice Gel Packs Eaggies Foam Block Paper Other: _____
 Was sufficient ice used (if appropriate)? NA YES NO
 Were all bottles sealed in individual plastic bags? YES NO
 Did all bottles arrive in good condition (unbroken)? YES NO
 Were all bottle labels complete and legible? YES NO
 Did the number of containers listed on COC match with the number of containers received? YES NO
 Did all bottle labels and tags agree with custody papers? YES NO
 Were all bottles used correct for the requested analyses? YES NO
 Do any of the analyses (bottles) require preservation? (attach preservation sheet, excluding VOCs)... NA YES NO
 Were all VOC vials free of air bubbles? NA YES NO
 Was sufficient amount of sample sent in each bottle? YES NO
 Date VOC Trip Blank was made at ARI: NA
 Was Sample Split by ARI: NA YES Date/Time: _____ Equipment: _____ Split by: _____

Samples Logged by: [Signature] Date: 11-1-13 Time: 1520

**** Notify Project Manager of discrepancies or concerns ****

Sample ID on Bottle	Sample ID on COC	Sample ID on Bottle	Sample ID on COC

Additional Notes, Discrepancies, & Resolutions:

By: _____ Date: _____

	Small → "sm" (< 2 mm)
	Peabubbles → "pb" (2 to < 4 mm)
	Large → "lg" (4 to < 6 mm)
	Headspace → "hs" (> 6 mm)

Sample ID Cross Reference Report



ARI Job No: XN53
Client: Landau Associates, Inc.
Project Event: 118033.100.104
Project Name: Kaiser IA

Sample ID	ARI Lab ID	ARI LIMS ID	Matrix	Sample Date/Time	VTSR
1. SPL-53-20131111	XN53A	13-24772	Soil	11/11/13 10:28	11/11/13 13:40
2. SPL-54-20131111	XN53B	13-24773	Soil	11/11/13 10:39	11/11/13 13:40
3. SPL-55-20131111	XN53C	13-24774	Soil	11/11/13 10:49	11/11/13 13:40
4. SPL-63-20131111	XN53D	13-24775	Soil	11/11/13 11:30	11/11/13 13:40
5. SPL-65-20131111	XN53E	13-24776	Soil	11/11/13 12:27	11/11/13 13:40
6. SPL-66-20131111	XN53F	13-24777	Soil	11/11/13 12:15	11/11/13 13:40
7. SPL-67-20131111	XN53G	13-24778	Soil	11/11/13 12:01	11/11/13 13:40
8. SPL-68-20131111	XN53H	13-24779	Soil	11/11/13 11:52	11/11/13 13:40

ORGANICS ANALYSIS DATA SHEET

PNAs by SW8270D GC/MS

Page 1 of 1

Sample ID: SPL-53-20131111

SAMPLE

Lab Sample ID: XN53A

LIMS ID: 13-24772

Matrix: Soil

Data Release Authorized: *AS*

Reported: 11/12/13

QC Report No: XN53-Landau Associates, Inc.

Project: Kaiser IA

118033.100.104

Date Sampled: 11/11/13

Date Received: 11/11/13

Date Extracted: 11/11/13

Date Analyzed: 11/12/13 11:28

Instrument/Analyst: NT6/JZ

GPC Cleanup: No

Alumina: No

Silica Gel: No

Sample Amount: 8.36 g-dry-wt

Final Extract Volume: 0.5 mL

Dilution Factor: 1.00

Percent Moisture: 7.2%

CAS Number	Analyte	RL	Result
56-55-3	Benzo (a) anthracene	60	1,800
218-01-9	Chrysene	60	2,300
50-32-8	Benzo (a) pyrene	60	2,200
193-39-5	Indeno (1,2,3-cd) pyrene	60	1,400
53-70-3	Dibenz (a,h) anthracene	60	690
TOTBFA	Total Benzofluoranthenes	60	3,200

Reported in µg/kg (ppb)

Semivolatile Surrogate Recovery

d14-p-Terphenyl	79.6%
2-Fluorobiphenyl	85.2%

ORGANICS ANALYSIS DATA SHEET

PNAs by SW8270D GC/MS

Page 1 of 1

**Sample ID: SPL-54-20131111
SAMPLE**

Lab Sample ID: XN53B
LIMS ID: 13-24773
Matrix: Soil
Data Release Authorized: *[Signature]*
Reported: 11/12/13

QC Report No: XN53-Landau Associates, Inc.
Project: Kaiser IA
118033.100.104
Date Sampled: 11/11/13
Date Received: 11/11/13

Date Extracted: 11/11/13
Date Analyzed: 11/12/13 12:02
Instrument/Analyst: NT6/JZ
GPC Cleanup: No
Alumina: No
Silica Gel: No

Sample Amount: 7.52 g-dry-wt
Final Extract Volume: 0.5 mL
Dilution Factor: 1.00
Percent Moisture: 16.5%

CAS Number	Analyte	RL	Result
56-55-3	Benzo (a) anthracene	66	1,800
218-01-9	Chrysene	66	2,300
50-32-8	Benzo (a) pyrene	66	2,200
193-39-5	Indeno (1,2,3-cd) pyrene	66	1,400
53-70-3	Dibenz (a,h) anthracene	66	720
TOTBFA	Total Benzofluoranthenes	66	3,200

Reported in µg/kg (ppb)

Semivolatile Surrogate Recovery

d14-p-Terphenyl	73.6%
2-Fluorobiphenyl	78.4%

ORGANICS ANALYSIS DATA SHEET

PNAs by SW8270D GC/MS

Page 1 of 1

Sample ID: SPL-55-20131111

SAMPLE

Lab Sample ID: XN53C

LIMS ID: 13-24774

Matrix: Soil

Data Release Authorized:

Reported: 11/12/13

QC Report No: XN53-Landau Associates, Inc.

Project: Kaiser IA

118033.100.104

Date Sampled: 11/11/13

Date Received: 11/11/13

Date Extracted: 11/11/13

Date Analyzed: 11/11/13 22:46

Instrument/Analyst: NT6/JZ

GPC Cleanup: No

Alumina: No

Silica Gel: No

Sample Amount: 8.34 g-dry-wt

Final Extract Volume: 0.5 mL

Dilution Factor: 1.00

Percent Moisture: 7.7%

CAS Number	Analyte	RL	Result
56-55-3	Benzo(a)anthracene	60	< 60 U
218-01-9	Chrysene	60	< 60 U
50-32-8	Benzo(a)pyrene	60	< 60 U
193-39-5	Indeno(1,2,3-cd)pyrene	60	< 60 U
53-70-3	Dibenz(a,h)anthracene	60	< 60 U
TOTBFA	Total Benzofluoranthenes	60	< 60 U

Reported in µg/kg (ppb)

Semivolatile Surrogate Recovery

d14-p-Terphenyl	74.4%
2-Fluorobiphenyl	74.0%

ORGANICS ANALYSIS DATA SHEET

PNAs by SW8270D GC/MS

Page 1 of 1

Sample ID: SPL-63-20131111

SAMPLE

Lab Sample ID: XN53D

LIMS ID: 13-24775

Matrix: Soil

Data Release Authorized: *AS*

Reported: 11/12/13

QC Report No: XN53-Landau Associates, Inc.

Project: Kaiser IA

118033.100.104

Date Sampled: 11/11/13

Date Received: 11/11/13

Date Extracted: 11/11/13

Date Analyzed: 11/11/13 23:19

Instrument/Analyst: NT6/JZ

GPC Cleanup: No

Alumina: No

Silica Gel: No

Sample Amount: 7.31 g-dry-wt

Final Extract Volume: 0.5 mL

Dilution Factor: 1.00

Percent Moisture: 19.0%

CAS Number	Analyte	RL	Result
56-55-3	Benzo(a)anthracene	68	< 68 U
218-01-9	Chrysene	68	< 68 U
50-32-8	Benzo(a)pyrene	68	< 68 U
193-39-5	Indeno(1,2,3-cd)pyrene	68	< 68 U
53-70-3	Dibenz(a,h)anthracene	68	< 68 U
TOTBFA	Total Benzofluoranthenes	68	< 68 U

Reported in µg/kg (ppb)

Semivolatile Surrogate Recovery

d14-p-Terphenyl	69.6%
2-Fluorobiphenyl	63.6%

ORGANICS ANALYSIS DATA SHEET

PNAs by SW8270D GC/MS

Page 1 of 1

**Sample ID: SPL-65-20131111
SAMPLE**

Lab Sample ID: XN53E
LIMS ID: 13-24776
Matrix: Soil
Data Release Authorized:
Reported: 11/12/13

QC Report No: XN53-Landau Associates, Inc.
Project: Kaiser IA
118033.100.104
Date Sampled: 11/11/13
Date Received: 11/11/13

Date Extracted: 11/11/13
Date Analyzed: 11/11/13 23:53
Instrument/Analyst: NT6/JZ
GPC Cleanup: No
Alumina: No
Silica Gel: No

Sample Amount: 7.96 g-dry-wt
Final Extract Volume: 0.5 mL
Dilution Factor: 1.00
Percent Moisture: 12.0%

CAS Number	Analyte	RL	Result
56-55-3	Benzo(a)anthracene	63	< 63 U
218-01-9	Chrysene	63	< 63 U
50-32-8	Benzo(a)pyrene	63	< 63 U
193-39-5	Indeno(1,2,3-cd)pyrene	63	< 63 U
53-70-3	Dibenz(a,h)anthracene	63	< 63 U
TOTBFA	Total Benzofluoranthenes	63	< 63 U

Reported in µg/kg (ppb)

Semivolatile Surrogate Recovery

d14-p-Terphenyl	68.4%
2-Fluorobiphenyl	65.2%

ORGANICS ANALYSIS DATA SHEET

PNAs by SW8270D GC/MS

Page 1 of 1

**Sample ID: SPL-66-20131111
SAMPLE**

Lab Sample ID: XN53F

LIMS ID: 13-24777

Matrix: Soil

Data Release Authorized: *AS*

Reported: 11/12/13

QC Report No: XN53-Landau Associates, Inc.

Project: Kaiser IA

118033.100.104

Date Sampled: 11/11/13

Date Received: 11/11/13

Date Extracted: 11/11/13

Date Analyzed: 11/12/13 00:27

Instrument/Analyst: NT6/JZ

GPC Cleanup: No

Alumina: No

Silica Gel: No

Sample Amount: 8.13 g-dry-wt

Final Extract Volume: 0.5 mL

Dilution Factor: 1.00

Percent Moisture: 9.8%

CAS Number	Analyte	RL	Result
56-55-3	Benzo(a)anthracene	62	< 62 U
218-01-9	Chrysene	62	< 62 U
50-32-8	Benzo(a)pyrene	62	< 62 U
193-39-5	Indeno(1,2,3-cd)pyrene	62	< 62 U
53-70-3	Dibenz(a,h)anthracene	62	< 62 U
TOTBFA	Total Benzofluoranthenes	62	< 62 U

Reported in µg/kg (ppb)

Semivolatile Surrogate Recovery

d14-p-Terphenyl	72.8%
2-Fluorobiphenyl	70.4%

ORGANICS ANALYSIS DATA SHEET

PNAs by SW8270D GC/MS

Page 1 of 1

Sample ID: SPL-67-20131111

SAMPLE

Lab Sample ID: XN53G

LIMS ID: 13-24778

Matrix: Soil

Data Release Authorized: *[Signature]*

Reported: 11/12/13

QC Report No: XN53-Landau Associates, Inc.

Project: Kaiser IA

118033.100.104

Date Sampled: 11/11/13

Date Received: 11/11/13

Date Extracted: 11/11/13

Date Analyzed: 11/12/13 01:01

Instrument/Analyst: NT6/JZ

GPC Cleanup: No

Alumina: No

Silica Gel: No

Sample Amount: 8.27 g-dry-wt

Final Extract Volume: 0.5 mL

Dilution Factor: 1.00

Percent Moisture: 8.6%

CAS Number	Analyte	RL	Result
56-55-3	Benzo(a)anthracene	60	< 60 U
218-01-9	Chrysene	60	< 60 U
50-32-8	Benzo(a)pyrene	60	< 60 U
193-39-5	Indeno(1,2,3-cd)pyrene	60	< 60 U
53-70-3	Dibenz(a,h)anthracene	60	< 60 U
TOTBFA	Total Benzofluoranthenes	60	< 60 U

Reported in µg/kg (ppb)

Semivolatile Surrogate Recovery

d14-p-Terphenyl	74.0%
2-Fluorobiphenyl	69.6%

ORGANICS ANALYSIS DATA SHEET

PNAs by SW8270D GC/MS

Page 1 of 1

Sample ID: SPL-68-20131111

SAMPLE

Lab Sample ID: XN53H

LIMS ID: 13-24779

Matrix: Soil

Data Release Authorized: *B*

Reported: 11/12/13

QC Report No: XN53-Landau Associates, Inc.

Project: Kaiser IA

118033.100.104

Date Sampled: 11/11/13

Date Received: 11/11/13

Date Extracted: 11/11/13

Date Analyzed: 11/12/13 12:36

Instrument/Analyst: NT6/JZ

GPC Cleanup: No

Alumina: No

Silica Gel: No

Sample Amount: 7.27 g-dry-wt

Final Extract Volume: 0.5 mL

Dilution Factor: 1.00

Percent Moisture: 19.5%

CAS Number	Analyte	RL	Result
56-55-3	Benzo (a) anthracene	69	510
218-01-9	Chrysene	69	630
50-32-8	Benzo (a) pyrene	69	510
193-39-5	Indeno (1,2,3-cd) pyrene	69	290
53-70-3	Dibenz (a,h) anthracene	69	130
TOTBFA	Total Benzofluoranthenes	69	980

Reported in µg/kg (ppb)

Semivolatile Surrogate Recovery

d14-p-Terphenyl	68.0%
2-Fluorobiphenyl	73.2%

ORGANICS ANALYSIS DATA SHEET

PNAs by SW8270D GC/MS

Page 1 of 1

Sample ID: MB-111113

METHOD BLANK

Lab Sample ID: MB-111113

LIMS ID: 13-24779

Matrix: Soil

Data Release Authorized:

Reported: 11/12/13

QC Report No: XN53-Landau Associates, Inc.

Project: Kaiser IA

118033.100.104

Date Sampled: NA

Date Received: NA

Date Extracted: 11/11/13

Date Analyzed: 11/11/13 19:56

Instrument/Analyst: NT6/JZ

GPC Cleanup: No

Alumina: No

Silica Gel: No

Sample Amount: 7.50 g-dry-wt

Final Extract Volume: 0.5 mL

Dilution Factor: 1.00

Percent Moisture: NA

CAS Number	Analyte	RL	Result
56-55-3	Benzo(a)anthracene	67	< 67 U
218-01-9	Chrysene	67	< 67 U
50-32-8	Benzo(a)pyrene	67	< 67 U
193-39-5	Indeno(1,2,3-cd)pyrene	67	< 67 U
53-70-3	Dibenz(a,h)anthracene	67	< 67 U
TOTBFA	Total Benzofluoranthenes	67	< 67 U

Reported in µg/kg (ppb)

Semivolatile Surrogate Recovery

d14-p-Terphenyl	82.8%
2-Fluorobiphenyl	81.2%

SW8270 PNA SURROGATE RECOVERY SUMMARY

Matrix: Soil

QC Report No: XN53-Landau Associates, Inc.
Project: Kaiser IA
118033.100.104

<u>Client ID</u>	<u>TER</u>	<u>FBP</u>	<u>TOT OUT</u>
SPL-53-20131111	79.6%	85.2%	0
SPL-54-20131111	73.6%	78.4%	0
SPL-55-20131111	74.4%	74.0%	0
SPL-63-20131111	69.6%	63.6%	0
SPL-65-20131111	68.4%	65.2%	0
SPL-66-20131111	72.8%	70.4%	0
SPL-67-20131111	74.0%	69.6%	0
MB-111113	82.8%	81.2%	0
LCS-111113	86.4%	78.8%	0
LCSD-111113	80.0%	77.6%	0
SPL-68-20131111	68.0%	73.2%	0

LCS/MB LIMITS QC LIMITS

(TER) = d14-p-Terphenyl (30-160) (30-160)
(FBP) = 2-Fluorobiphenyl (30-160) (30-160)

Prep Method: SW3546
Log Number Range: 13-24772 to 13-24779

ORGANICS ANALYSIS DATA SHEET

PNAs by SW8270D GC/MS

Page 1 of 1

**Sample ID: LCS-111113
LCS/LCSD**

Lab Sample ID: LCS-111113

LIMS ID: 13-24779

Matrix: Soil

Data Release Authorized: *[Signature]*

Reported: 11/12/13

QC Report No: XN53-Landau Associates, Inc.

Project: Kaiser IA

118033.100.104

Date Sampled: NA

Date Received: 11/11/13

Date Extracted LCS/LCSD: 11/11/13

Sample Amount LCS: 7.50 g-dry-wt

LCSD: 7.50 g-dry-wt

Date Analyzed LCS: 11/11/13 20:30

Final Extract Volume LCS: 0.50 mL

LCSD: 11/11/13 21:04

LCSD: 0.50 mL

Instrument/Analyst LCS: NT6/JZ

Dilution Factor LCS: 1.00

LCSD: NT6/JZ

LCSD: 1.00

GPC Cleanup: No

Alumina Cleanup: No

Silica Gel Cleanup: No

Analyte	LCS			LCSD			RPD
	LCS	Spike Added-LCS	LCS Recovery	LCSD	Spike Added-LCSD	LCSD Recovery	
Benzo(a)anthracene	1500	1670	89.8%	1480	1670	88.6%	1.3%
Chrysene	1470	1670	88.0%	1460	1670	87.4%	0.7%
Benzo(a)pyrene	1610	1670	96.4%	1600	1670	95.8%	0.6%
Indeno(1,2,3-cd)pyrene	1740 Q	1670	104%	1710 Q	1670	102%	1.7%
Dibenz(a,h)anthracene	1770 Q	1670	106%	1740 Q	1670	104%	1.7%
Total Benzofluoranthenes	2950	3330	88.6%	2900	3330	87.1%	1.7%

Semivolatile Surrogate Recovery

	LCS	LCSD
d14-p-Terphenyl	86.4%	80.0%
2-Fluorobiphenyl	78.8%	77.6%

Results reported in µg/kg

RPD calculated using sample concentrations per SW846.



Analytical Resources, Incorporated
Analytical Chemists and Consultants

November 13, 2013

Dave Pischer
Landau Associates, Inc.
950 Pacific Ave # 515
Tacoma, WA 98402

RE: Project: Kaiser IA, 118033.100.104
ARI Job No: XN66

Dear Dave:

Please find enclosed the original Chain-of-Custody record (COC), sample receipt documentation, and analytical results for samples from the projects referenced above. Analytical Resources, Inc. (ARI) accepted one soil sample on November 12, 2013 in good condition. For further details regarding sample receipt, please refer to the enclosed Cooler Receipt Form.

The samples were analyzed for cPAHs, as requested on the COC.

No analytical complications were noted.

An electronic copy of this report and all associated raw data will remain on file with ARI. If you have any questions or require additional information, please feel free to contact me at your convenience.

Sincerely,
ANALYTICAL RESOURCES, INC.

A handwritten signature in black ink, appearing to read "Kelly Bottem".

Kelly Bottem
Client Services Manager
206/695-6211
kellyb@arilabs.com

Enclosures

1 OF 8

XN266

Chain-of-Custody Record

Project Information			Testing Parameters		Observations/Comments
Project Name	Project No.	Turnaround Time			
Kaiser IA	118033.100.104	<input type="checkbox"/> Standard <input type="checkbox"/> Accelerated <input checked="" type="checkbox"/> 1-2 Day TAT			X Allow water samples to settle, collect aliquot from clear portion X NWTPH-Dx - run acid wash/silica gel cleanup ___ run samples standardized to ___ product ___ Analyze for EPH if no specific product identified VOC/BTEX/VPH (soil): ___ non-preserved ___ preserved w/methanol ___ preserved w/sodium bisulfate ___ Freeze upon receipt ___ Dissolved metal water samples field filtered Other _____
Project Location/Event	Date	Time	Matrix	No. of Containers	
Port of Tacoma	11/12/13	08:45	Soil	1	
Sampler's Name	Date	Time	Matrix	No. of Containers	
DAR					
Project Contact	Date	Time	Matrix	No. of Containers	
Send Results To	Date	Time	Matrix	No. of Containers	
DAVE FISCHER					
SISS STINE, SIERRA MOTT					
ANNE HELMSEN, BILL EVANS, DAVE FISCHER					
SPL-62-20131112	11/12/13	08:45	Soil	1	
Special Shipment/Handling or Storage Requirements: <u>On ice</u>					
Relinquished by			Relinquished by		Method of Shipment
Signature	Signature	Signature	Signature	Signature	Courier
David Rupert	Sierra Mott	Sierra Mott	Sierra Mott	Sierra Mott	
Printed Name	Printed Name	Printed Name	Printed Name	Printed Name	
Landau Assoc., Inc.	Landau Associates	Landau Associates	Landau Associates	Landau Associates	
Company	Company	Company	Company	Company	
Date	Date	Date	Date	Date	
11/12/13	11/12/13	11/12/13	11/12/13	11/12/13	
Time 11:50	Time 11:30	Time 11:30	Time 14:25	Time 14:25	

XN266 : 000002

Sample ID Cross Reference Report



ARI Job No: XN66
Client: Landau Associates, Inc.
Project Event: 118033.100.104
Project Name: Kaiser IA

Sample ID	ARI Lab ID	ARI LIMS ID	Matrix	Sample Date/Time	VTSR
1. SPL-62-20131112	XN66A	13-24880	Soil	11/12/13 08:45	11/12/13 14:25



Cooler Receipt Form

ARI Client: LAI

Project Name: Kaiser IA

COC No(s): _____ (NA)

Delivered by Fed-Ex UPS Courier Hand Delivered Other: _____

Assigned ARI Job No: XN66

Tracking No _____ (NA)

Preliminary Examination Phase:

Were intact, properly signed and dated custody seals attached to the outside of to cooler? YES NO
 Were custody papers included with the cooler? YES NO
 Were custody papers properly filled out (ink, signed, etc.) YES NO

Temperature of Cooler(s) (°C) (recommended 2.0-6.0 °C for chemistry)

Time 1550

If cooler temperature is out of compliance fill out form 00070F

Temp Gun ID#: 90877952 ⁵⁴

Cooler Accepted by _____ Date: 11/12/13 Time: 1425

Complete custody forms and attach all shipping documents

Log-In Phase:

Was a temperature blank included in the cooler? YES NO
 What kind of packing material was used? Bubble Wrap Wet Ice Gel Packs Baggies Foam Block Paper Other: _____
 Was sufficient ice used (if appropriate)? NA YES NO
 Were all bottles sealed in individual plastic bags? YES NO
 Did all bottles arrive in good condition (unbroken)? YES NO
 Were all bottle labels complete and legible? YES NO
 Did the number of containers listed on COC match with the number of containers received? YES NO
 Did all bottle labels and tags agree with custody papers? YES NO
 Were all bottles used correct for the requested analyses? YES NO
 Do any of the analyses (bottles) require preservation? (attach preservation sheet, excluding VOCs) NA YES NO
 Were all VOC vials free of air bubbles? NA YES NO
 Was sufficient amount of sample sent in each bottle? YES NO
 Date VOC Trip Blank was made at ARI NA
 Was Sample Split by ARI NA YES Date/Time: _____ Equipment: _____ Split by: _____

Samples Logged by AV Date: 11/12/13 Time: 1600

**** Notify Project Manager of discrepancies or concerns ****

Sample ID on Bottle	Sample ID on COC	Sample ID on Bottle	Sample ID on COC

Additional Notes, Discrepancies, & Resolutions:

By _____ Date: _____

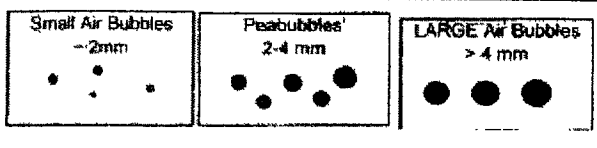

- Small → "sm" (< 2 mm)
- Peabubbles → "pb" (2 to < 4 mm)
- Large → "lg" (4 to < 6 mm)
- Headspace → "hs" (> 6 mm)

ORGANICS ANALYSIS DATA SHEET

PNAs by SW8270D GC/MS

Page 1 of 1

**Sample ID: SPL-62-20131112
SAMPLE**

Lab Sample ID: XN66A

LIMS ID: 13-24880

Matrix: Soil

Data Release Authorized: 

Reported: 11/13/13

QC Report No: XN66-Landau Associates, Inc.

Project: Kaiser IA

118033.100.104

Date Sampled: 11/12/13

Date Received: 11/12/13

Date Extracted: 11/12/13

Date Analyzed: 11/12/13 20:45

Instrument/Analyst: NT6/JZ

GPC Cleanup: No

Alumina: No

Silica Gel: No

Sample Amount: 9.04 g-dry-wt

Final Extract Volume: 0.5 mL

Dilution Factor: 1.00

Percent Moisture: 11.8%

CAS Number	Analyte	RL	Result
56-55-3	Benzo(a)anthracene	55	< 55 U
218-01-9	Chrysene	55	< 55 U
50-32-8	Benzo(a)pyrene	55	< 55 U
193-39-5	Indeno(1,2,3-cd)pyrene	55	< 55 U
53-70-3	Dibenz(a,h)anthracene	55	< 55 U
TOTBFA	Total Benzofluoranthenes	55	< 55 U

Reported in µg/kg (ppb)

Semivolatile Surrogate Recovery

d14-p-Terphenyl	79.6%
2-Fluorobiphenyl	75.6%

ORGANICS ANALYSIS DATA SHEET

PNAs by SW8270D GC/MS

Page 1 of 1

Sample ID: MB-111213

METHOD BLANK

Lab Sample ID: MB-111213

LIMS ID: 13-24880

Matrix: Soil

Data Release Authorized: *AB*

Reported: 11/13/13

QC Report No: XN66-Landau Associates, Inc.

Project: Kaiser IA

118033.100.104

Date Sampled: NA

Date Received: NA

Date Extracted: 11/12/13

Date Analyzed: 11/12/13 19:04

Instrument/Analyst: NT6/JZ

GPC Cleanup: No

Alumina: No

Silica Gel: No

Sample Amount: 7.50 g-dry-wt

Final Extract Volume: 0.5 mL

Dilution Factor: 1.00

Percent Moisture: NA

CAS Number	Analyte	RL	Result
56-55-3	Benzo(a)anthracene	67	< 67 U
218-01-9	Chrysene	67	< 67 U
50-32-8	Benzo(a)pyrene	67	< 67 U
193-39-5	Indeno(1,2,3-cd)pyrene	67	< 67 U
53-70-3	Dibenz(a,h)anthracene	67	< 67 U
TOTBFA	Total Benzofluoranthenes	67	< 67 U

Reported in µg/kg (ppb)

Semivolatile Surrogate Recovery

d14-p-Terphenyl	80.4%
2-Fluorobiphenyl	79.6%

SW8270 PNA SURROGATE RECOVERY SUMMARY

Matrix: Soil

QC Report No: XN66-Landau Associates, Inc.
Project: Kaiser IA
118033.100.104

<u>Client ID</u>	<u>TER</u>	<u>FBP</u>	<u>TOT OUT</u>
MB-111213	80.4%	79.6%	0
LCS-111213	81.2%	80.0%	0
LCSD-111213	86.8%	78.4%	0
SPL-62-20131112	79.6%	75.6%	0

LCS/MB LIMITS QC LIMITS

(TER) = d14-p-Terphenyl (30-160) (30-160)
(FBP) = 2-Fluorobiphenyl (30-160) (30-160)

Prep Method: SW3546
Log Number Range: 13-24880 to 13-24880



ORGANICS ANALYSIS DATA SHEET

PNAs by SW8270D GC/MS

Page 1 of 1

Sample ID: LCS-111213

LCS/LCSD

Lab Sample ID: LCS-111213

LIMS ID: 13-24880

Matrix: Soil

Data Release Authorized: *[Signature]*

Reported: 11/13/13

QC Report No: XN66-Landau Associates, Inc.

Project: Kaiser IA

118033.100.104

Date Sampled: NA

Date Received: 11/12/13

Date Extracted LCS/LCSD: 11/12/13

Sample Amount LCS: 7.50 g-dry-wt

LCSD: 7.50 g-dry-wt

Date Analyzed LCS: 11/12/13 19:37

Final Extract Volume LCS: 0.50 mL

LCSD: 11/12/13 20:11

LCSD: 0.50 mL

Instrument/Analyst LCS: NT6/JZ

Dilution Factor LCS: 1.00

LCSD: NT6/JZ

LCSD: 1.00

GPC Cleanup: No

Alumina Cleanup: No

Silica Gel Cleanup: No

Analyte	LCS	Spike Added-LCS	LCS Recovery	LCS	Spike Added-LCSD	LCSD Recovery	RPD
Benzo(a)anthracene	1500	1670	89.8%	1580	1670	94.6%	5.2%
Chrysene	1450	1670	86.8%	1520	1670	91.0%	4.7%
Benzo(a)pyrene	1640	1670	98.2%	1670	1670	100%	1.8%
Indeno(1,2,3-cd)pyrene	1640	1670	98.2%	1740	1670	104%	5.9%
Dibenz(a,h)anthracene	1660	1670	99.4%	1680	1670	101%	1.2%
Total Benzofluoranthenes	2940	3330	88.3%	3050	3330	91.6%	3.7%

Semivolatile Surrogate Recovery

	LCS	LCSD
d14-p-Terphenyl	81.2%	86.8%
2-Fluorobiphenyl	80.0%	78.4%

Results reported in µg/kg

RPD calculated using sample concentrations per SW846.



Analytical Resources, Incorporated
Analytical Chemists and Consultants

November 14, 2013

Dave Pischer
Landau Associates, Inc.
950 Pacific Ave # 515
Tacoma, WA 98402

RE: Project: Kaiser IA, 118033.100.104
ARI Job No: XN77

Dear Dave:

Please find enclosed the original Chain-of-Custody record (COC), sample receipt documentation, and analytical results for samples from the projects referenced above. Analytical Resources, Inc. (ARI) accepted three soil samples on November 13, 2013 in good condition. For further details regarding sample receipt, please refer to the enclosed Cooler Receipt Form.

The samples were analyzed for cPAHs, as requested on the COC.

No analytical complications were noted.

An electronic copy of this report and all associated raw data will remain on file with ARI. If you have any questions or require additional information, please feel free to contact me at your convenience.

Sincerely,
ANALYTICAL RESOURCES, INC.

Kelly Bottem
Client Services Manager
206/695-6211
kellyb@arilabs.com

Enclosures

1 OF 10

- Seattle/Edmonds (425) 778-0907
- Tacoma (253) 926-2493
- Spokane (509) 327-9737
- Portland (503) 542-1080



Chain-of-Custody Record

Date 11/13/2013
 Page 1 of 1

Project Name Kaiser IA Project No. 118033.100.104
 Project Location/Event Kaiser, Port of Tacoma
 Sampler's Name DAR
 Project Contact DAVE PISCHER
 Send Results To Jess Stone, Steve Metz, Anne Helverson, Bill Evans, Dave Fisher

Testing Parameters

Turnaround Time
 Standard
 Accelerated
 1-2 Day TAT

C PAK B270 D

Sample I.D.	Date	Time	Matrix	No. of Containers	Observations/Comments
SPL-53-20131113	11/13/13	08:58	Soil	1	X Allow water samples to settle, collect aliquot from clear portion
SPL-54-20131113	11/13/13	09:27	Soil	1	X NWTPH-Dx - run acid wash/silica gel cleanup
SPL-68-20131113	11/13/13	10:19	Soil	1	run samples standardized to product
					Analyze for EPH if no specific product identified
					VOC/BTEX/VPH (soil):
					non-preserved
					preserved w/methanol
					preserved w/sodium bisulfate
					Freeze upon receipt
					Dissolved metal water samples field filtered
					Other

Special Shipment/Handling or Storage Requirements On ice

Method of Shipment Courier

Received by
 Signature [Signature]
 Printed Name Dave Rupert
 Company Landau Assoc, Inc
 Date 11/13/13 Time 1145

Relinquished by
 Signature [Signature]
 Printed Name ARI
 Company [Signature]
 Date 11/13/13 Time 1145

Received by
 Signature _____
 Printed Name _____
 Company _____
 Date _____ Time _____

Relinquished by
 Signature _____
 Printed Name _____
 Company _____
 Date _____ Time _____



Cooler Receipt Form

ARI Client Landau

Project Name Kaiser IA

COC No(s): _____ (NA)

Delivered by Fed-Ex UPS Courier Hand Delivered Other _____

Assigned ARI Job No: XN77

Tracking No. _____ NA

Preliminary Examination Phase:

Were intact, properly signed and dated custody seals attached to the outside of to cooler? YES NO
 Were custody papers included with the cooler? YES NO
 Were custody papers properly filled out (ink, signed, etc) YES NO
 Temperature of Cooler(s) (°C) (recommended 2.0-6.0 °C for chemistry)
 Time 1340 4.3

If cooler temperature is out of compliance fill out form 00070F Temp Gun ID#: 90877952

Cooler Accepted by: _____ Date 11/13/13 Time: 1145

Complete custody forms and attach all shipping documents

Log-In Phase:

Was a temperature blank included in the cooler? YES NO
 What kind of packing material was used? Bubble Wrap Wet Ice Gel Packs Baggies Foam Block Paper Other _____
 Was sufficient ice used (if appropriate)? NA YES NO
 Were all bottles sealed in individual plastic bags? YES NO
 Did all bottles arrive in good condition (unbroken)? YES NO
 Were all bottle labels complete and legible? YES NO
 Did the number of containers listed on COC match with the number of containers received? YES NO
 Did all bottle labels and tags agree with custody papers? YES NO
 Were all bottles used correct for the requested analyses? YES NO
 Do any of the analyses (bottles) require preservation? (attach preservation sheet, excluding VOCs) NA YES NO
 Were all VOC vials free of air bubbles? NA YES NO
 Was sufficient amount of sample sent in each bottle? YES NO
 Date VOC Trip Blank was made at ARI NA _____
 Was Sample Split by ARI NA YES Date/Time: _____ Equipment _____ Split by: _____

Samples Logged by JM Date 11/13/13 Time: 1357

**** Notify Project Manager of discrepancies or concerns ****

Sample ID on Bottle	Sample ID on COC	Sample ID on Bottle	Sample ID on COC

Additional Notes, Discrepancies, & Resolutions:

By: _____ Date: _____

			Small → "sm" (< 2 mm)
			Peabubbles → "pb" (2 to < 4 mm)
			Large → "lg" (4 to < 6 mm)
			Headspace → "hs" (> 6 mm)

Sample ID Cross Reference Report



ARI Job No: XN77
Client: Landau Associates, Inc.
Project Event: 118033.100.104
Project Name: Kaiser IA

Sample ID	ARI Lab ID	ARI LIMS ID	Matrix	Sample Date/Time	VTSR
1. SPL-53-20131113	XN77A	13-24930	Soil	11/13/13 08:58	11/13/13 11:45
2. SPL-54-20131113	XN77B	13-24931	Soil	11/13/13 09:27	11/13/13 11:45
3. SPL-68-20131113	XN77C	13-24932	Soil	11/13/13 10:19	11/13/13 11:45

ORGANICS ANALYSIS DATA SHEET

PNAs by SW8270D GC/MS

Page 1 of 1

Sample ID: SPL-53-20131113

SAMPLE

Lab Sample ID: XN77A

LIMS ID: 13-24930

Matrix: Soil

Data Release Authorized: *B*

Reported: 11/14/13

QC Report No: XN77-Landau Associates, Inc.

Project: Kaiser IA

118033.100.104

Date Sampled: 11/13/13

Date Received: 11/13/13

Date Extracted: 11/13/13

Date Analyzed: 11/13/13 20:05

Instrument/Analyst: NT6/JZ

GPC Cleanup: No

Alumina: No

Silica Gel: No

Sample Amount: 7.89 g-dry-wt

Final Extract Volume: 0.5 mL

Dilution Factor: 1.00

Percent Moisture: 21.3%

CAS Number	Analyte	RL	Result
56-55-3	Benzo(a)anthracene	63	< 63 U
218-01-9	Chrysene	63	< 63 U
50-32-8	Benzo(a)pyrene	63	< 63 U
193-39-5	Indeno(1,2,3-cd)pyrene	63	< 63 U
53-70-3	Dibenz(a,h)anthracene	63	< 63 U
TOTBFA	Total Benzofluoranthenes	63	< 63 U

Reported in µg/kg (ppb)

Semivolatile Surrogate Recovery

d14-p-Terphenyl	75.2%
2-Fluorobiphenyl	67.6%

ORGANICS ANALYSIS DATA SHEET

PNAs by SW8270D GC/MS

Page 1 of 1

Sample ID: SPL-54-20131113

SAMPLE

Lab Sample ID: XN77B

LIMS ID: 13-24931

Matrix: Soil

Data Release Authorized: *AS*

Reported: 11/14/13

QC Report No: XN77-Landau Associates, Inc.

Project: Kaiser IA

118033.100.104

Date Sampled: 11/13/13

Date Received: 11/13/13

Date Extracted: 11/13/13

Date Analyzed: 11/13/13 20:38

Instrument/Analyst: NT6/JZ

GPC Cleanup: No

Alumina: No

Silica Gel: No

Sample Amount: 8.33 g-dry-wt

Final Extract Volume: 0.5 mL

Dilution Factor: 1.00

Percent Moisture: 16.8%

CAS Number	Analyte	RL	Result
56-55-3	Benzo(a)anthracene	60	< 60 U
218-01-9	Chrysene	60	< 60 U
50-32-8	Benzo(a)pyrene	60	< 60 U
193-39-5	Indeno(1,2,3-cd)pyrene	60	< 60 U
53-70-3	Dibenz(a,h)anthracene	60	< 60 U
TOTBFA	Total Benzofluoranthenes	60	< 60 U

Reported in µg/kg (ppb)

Semivolatile Surrogate Recovery

d14-p-Terphenyl	80.0%
2-Fluorobiphenyl	71.6%

ORGANICS ANALYSIS DATA SHEET

PNAs by SW8270D GC/MS

Page 1 of 1

Sample ID: SPL-68-20131113

SAMPLE

Lab Sample ID: XN77C

LIMS ID: 13-24932

Matrix: Soil

Data Release Authorized: *AB*

Reported: 11/14/13

QC Report No: XN77-Landau Associates, Inc.

Project: Kaiser IA

118033.100.104

Date Sampled: 11/13/13

Date Received: 11/13/13

Date Extracted: 11/13/13

Date Analyzed: 11/13/13 21:12

Instrument/Analyst: NT6/JZ

GPC Cleanup: No

Alumina: No

Silica Gel: No

Sample Amount: 7.93 g-dry-wt

Final Extract Volume: 0.5 mL

Dilution Factor: 1.00

Percent Moisture: 21.3%

CAS Number	Analyte	RL	Result
56-55-3	Benzo(a)anthracene	63	< 63 U
218-01-9	Chrysene	63	< 63 U
50-32-8	Benzo(a)pyrene	63	< 63 U
193-39-5	Indeno(1,2,3-cd)pyrene	63	< 63 U
53-70-3	Dibenz(a,h)anthracene	63	< 63 U
TOTBFA	Total Benzofluoranthenes	63	< 63 U

Reported in µg/kg (ppb)

Semivolatile Surrogate Recovery

d14-p-Terphenyl	77.6%
2-Fluorobiphenyl	69.6%

ORGANICS ANALYSIS DATA SHEET

PNAs by SW8270D GC/MS

Page 1 of 1

Sample ID: MB-111313

METHOD BLANK

Lab Sample ID: MB-111313

LIMS ID: 13-24930

Matrix: Soil

Data Release Authorized: *AB*

Reported: 11/14/13

QC Report No: XN77-Landau Associates, Inc.

Project: Kaiser IA

118033.100.104

Date Sampled: NA

Date Received: NA

Date Extracted: 11/13/13

Date Analyzed: 11/13/13 18:23

Instrument/Analyst: NT6/JZ

GPC Cleanup: No

Alumina: No

Silica Gel: No

Sample Amount: 7.50 g-dry-wt

Final Extract Volume: 0.5 mL

Dilution Factor: 1.00

Percent Moisture: NA

CAS Number	Analyte	RL	Result
56-55-3	Benzo(a)anthracene	67	< 67 U
218-01-9	Chrysene	67	< 67 U
50-32-8	Benzo(a)pyrene	67	< 67 U
193-39-5	Indeno(1,2,3-cd)pyrene	67	< 67 U
53-70-3	Dibenz(a,h)anthracene	67	< 67 U
TOTBFA	Total Benzofluoranthenes	67	< 67 U

Reported in µg/kg (ppb)

Semivolatile Surrogate Recovery

d14-p-Terphenyl	88.0%
2-Fluorobiphenyl	77.6%

SW8270 PNA SURROGATE RECOVERY SUMMARY

Matrix: Soil

QC Report No: XN77-Landau Associates, Inc.
Project: Kaiser IA
118033.100.104

<u>Client ID</u>	<u>TER</u>	<u>FBP</u>	<u>TOT OUT</u>
MB-111313	88.0%	77.6%	0
LCS-111313	88.8%	74.8%	0
LCSD-111313	88.0%	73.6%	0
SPL-53-20131113	75.2%	67.6%	0
SPL-54-20131113	80.0%	71.6%	0
SPL-68-20131113	77.6%	69.6%	0

LCS/MB LIMITS QC LIMITS

(TER) = d14-p-Terphenyl (30-160) (30-160)
(FBP) = 2-Fluorobiphenyl (30-160) (30-160)

Prep Method: SW3546
Log Number Range: 13-24930 to 13-24932

ORGANICS ANALYSIS DATA SHEET

PNAs by SW8270D GC/MS

Page 1 of 1

Sample ID: LCS-111313

LCS/LCSD

Lab Sample ID: LCS-111313

LIMS ID: 13-24930

Matrix: Soil

Data Release Authorized: *B*

Reported: 11/14/13

QC Report No: XN77-Landau Associates, Inc.

Project: Kaiser IA

118033.100.104

Date Sampled: NA

Date Received: 11/13/13

Date Extracted LCS/LCSD: 11/13/13

Sample Amount LCS: 7.50 g-dry-wt

LCSD: 7.50 g-dry-wt

Date Analyzed LCS: 11/13/13 18:57

Final Extract Volume LCS: 0.50 mL

LCSD: 11/13/13 19:31

LCSD: 0.50 mL

Instrument/Analyst LCS: NT6/JZ

Dilution Factor LCS: 1.00

LCSD: NT6/JZ

LCSD: 1.00

GPC Cleanup: No

Alumina Cleanup: No

Silica Gel Cleanup: No

Analyte	Spike		LCS		Spike		LCSD	
	LCS	Added-LCS	Recovery	LCS	Added-LCSD	Recovery	RPD	
Benzo(a)anthracene	1500	1670	89.8%	1540	1670	92.2%	2.6%	
Chrysene	1480	1670	88.6%	1500	1670	89.8%	1.3%	
Benzo(a)pyrene	1610	1670	96.4%	1660	1670	99.4%	3.1%	
Indeno(1,2,3-cd)pyrene	1560	1670	93.4%	1580	1670	94.6%	1.3%	
Dibenz(a,h)anthracene	1570	1670	94.0%	1580	1670	94.6%	0.6%	
Total Benzofluoranthenes	3060	3330	91.9%	3120	3330	93.7%	1.9%	

Semivolatile Surrogate Recovery

	LCS	LCSD
d14-p-Terphenyl	88.8%	88.0%
2-Fluorobiphenyl	74.8%	73.6%

Results reported in µg/kg

RPD calculated using sample concentrations per SW846.



Analytical Resources, Incorporated
Analytical Chemists and Consultants

November 18, 2013

Dave Pischer
Landau Associates, Inc.
950 Pacific Ave # 515
Tacoma, WA 98402

RE: Project: Kaiser IA, 118033.100.104
ARI Job No: XO06

Dear Dave:

Please find enclosed the original Chain-of-Custody record (COC), sample receipt documentation, and analytical results for samples from the projects referenced above. Analytical Resources, Inc. (ARI) accepted one soil sample on November 14, 2013 in good condition. For further details regarding sample receipt, please refer to the enclosed Cooler Receipt Form.

The samples were analyzed for cPAHs, as requested on the COC.

No analytical complications were noted.

An electronic copy of this report and all associated raw data will remain on file with ARI. If you have any questions or require additional information, please feel free to contact me at your convenience.

Sincerely,
ANALYTICAL RESOURCES, INC.

Kelly Bottem
Client Services Manager
206/695-6211
kellyb@arilabs.com

Enclosures

1 of 8

- Seattle/Edmonds (425) 778-0907
- Tacoma (253) 926-2493
- Spokane (509) 327-9737
- Portland (503) 542-1080



XCOB

Date 11/14/2013
Page 1 of 1

Chain-of-Custody Record

Project Name <u>Kaiser IA</u> Project No. <u>118 033.100.104</u> Project Location/Event <u>Kaiser, Port of Tacoma</u> Sampler's Name <u>DAR</u> Project Contact <u>Dave Fischer</u> Send Results To <u>Anne Halvorsen, Bill Evans, Dave Fischer</u>	Date <u>11/14/13</u> Time <u>9:53</u> Matrix <u>Soil</u> No. of Containers <u>1</u> <u>X</u> Sample I.D. <u>SPL-64-20131114</u>	Turnaround Time <input type="checkbox"/> Standard <input type="checkbox"/> Accelerated <input checked="" type="checkbox"/> <u>1-2 Day TAT</u>	Observations/Comments <input checked="" type="checkbox"/> Allow water samples to settle, collect aliquot from clear portion <input checked="" type="checkbox"/> NWTPH-Dx - run acid wash/silica gel cleanup ___ run samples standardized to ___ product ___ Analyze for EPH if no specific product identified VOC/BTEX/VPH (soil): ___ non-preserved ___ preserved w/methanol ___ preserved w/sodium bisulfate ___ Freeze upon receipt ___ Dissolved metal water samples field filtered Other _____
Testing Parameters			
<div style="border: 1px solid black; padding: 5px; transform: rotate(-45deg); display: inline-block;"> PRH 0270 D </div>			
Special Shipment/Handling or Storage Requirements <u>on-ice</u>		Method of Shipment <u>Courier</u>	
Relinquished by Signature <u>[Signature]</u> Printed Name <u>David Rupert</u> Company <u>Landau Assoc., Inc.</u> Date <u>11/14/13</u> Time <u>11:53</u>	Received by Signature <u>[Signature]</u> Printed Name <u>Sierra Mott</u> Company <u>Landan Associates, Inc.</u> Date <u>11/14/13</u> Time <u>11:53</u>	Relinquished by Signature <u>[Signature]</u> Printed Name <u>Sierra Mott</u> Company <u>Landan Associates</u> Date <u>11/14/13</u> Time <u>1431</u>	Received by Signature <u>[Signature]</u> Printed Name <u>Rich Halvorsen</u> Company <u>API</u> Date <u>11/14/13</u> Time <u>1430</u>

XCOB . 00000



Cooler Receipt Form

ARI Client LAI

Project Name Kaiser IA

COC No(s): _____ NA

Delivered by: Fed-Ex UPS Courier Hand Delivered Other _____

Assigned ARI Job No. X006

Tracking No: _____ NA

Preliminary Examination Phase:

Were intact, properly signed and dated custody seals attached to the outside of to cooler? YES NO

Were custody papers included with the cooler? YES NO

Were custody papers properly filled out (ink, signed, etc) YES NO

Temperature of Cooler(s) (°C) (recommended 2.0-6.0 °C for chemistry) 2.6

Time: 1505

If cooler temperature is out of compliance fill out form 00070F

Cooler Accepted by: _____ Date: 11/14/13 Time: 1430

Temp Bin ID#: 90877952

Complete custody forms and attach all shipping documents

Log-In Phase:

Was a temperature blank included in the cooler? YES NO

What kind of packing material was used? Bubble Wrap Wet Ice Gel Packs Baggies Foam Block Paper Other: _____

Was sufficient ice used (if appropriate)? NA YES NO

Were all bottles sealed in individual plastic bags? YES NO

Did all bottles arrive in good condition (unbroken)? YES NO

Were all bottle labels complete and legible? YES NO

Did the number of containers listed on COC match with the number of containers received? YES NO

Did all bottle labels and tags agree with custody papers? YES NO

Were all bottles used correct for the requested analyses? YES NO

Do any of the analyses (bottles) require preservation? (attach preservation sheet, excluding VOCs)... NA YES NO

Were all VOC vials free of air bubbles? NA YES NO

Was sufficient amount of sample sent in each bottle? YES NO

Date VOC Trip Blank was made at ARI. NA

Was Sample Split by ARI: NA YES Date/Time: _____ Equipment: _____ Split by: _____

Samples Logged by AV Date: 11/14/13 Time: 1525

**** Notify Project Manager of discrepancies or concerns ****

Sample ID on Bottle	Sample ID on COC	Sample ID on Bottle	Sample ID on COC

Additional Notes, Discrepancies, & Resolutions:

By: _____ Date: _____

			Small → "sm" (< 2 mm)
			Peabubbles → "pb" (2 to < 4 mm)
			Large → "lg" (4 to < 6 mm)
			Headspace → "hs" (> 6 mm)

Sample ID Cross Reference Report



ARI Job No: X006
Client: Landau Associates, Inc.
Project Event: 118033.100.104
Project Name: Kaiser IA

Sample ID	ARI Lab ID	ARI LIMS ID	Matrix	Sample Date/Time	VTSR
1. SPL-64-20131114	X006A	13-25187	Soil	11/14/13 09:53	11/14/13 14:30

ORGANICS ANALYSIS DATA SHEET

PNAs by SW8270D GC/MS

Page 1 of 1

Sample ID: SPL-64-20131114

SAMPLE

Lab Sample ID: X006A

LIMS ID: 13-25187

Matrix: Soil

Data Release Authorized: *B*

Reported: 11/18/13

QC Report No: X006-Landau Associates, Inc.

Project: Kaiser IA

118033.100.104

Date Sampled: 11/14/13

Date Received: 11/14/13

Date Extracted: 11/14/13

Date Analyzed: 11/16/13 16:09

Instrument/Analyst: NT6/JZ

GPC Cleanup: No

Alumina: No

Silica Gel: No

Sample Amount: 8.45 g-dry-wt

Final Extract Volume: 0.5 mL

Dilution Factor: 1.00

Percent Moisture: 23.5%

CAS Number	Analyte	RL	Result
56-55-3	Benzo(a)anthracene	59	< 59 U
218-01-9	Chrysene	59	< 59 U
50-32-8	Benzo(a)pyrene	59	< 59 U
193-39-5	Indeno(1,2,3-cd)pyrene	59	< 59 U
53-70-3	Dibenz(a,h)anthracene	59	< 59 U
TOTBFA	Total Benzofluoranthenes	59	< 59 U

Reported in µg/kg (ppb)

Semivolatile Surrogate Recovery

d14-p-Terphenyl	57.2%
2-Fluorobiphenyl	53.2%

ORGANICS ANALYSIS DATA SHEET

PNAs by SW8270D GC/MS

Page 1 of 1

Sample ID: MB-111413

METHOD BLANK

Lab Sample ID: MB-111413

LIMS ID: 13-25187

Matrix: Soil

Data Release Authorized: *[Signature]*

Reported: 11/18/13

QC Report No: X006-Landau Associates, Inc.

Project: Kaiser IA

118033.100.104

Date Sampled: NA

Date Received: NA

Date Extracted: 11/14/13

Date Analyzed: 11/16/13 14:28

Instrument/Analyst: NT6/JZ

GPC Cleanup: No

Alumina: No

Silica Gel: No

Sample Amount: 7.50 g-dry-wt

Final Extract Volume: 0.5 mL

Dilution Factor: 1.00

Percent Moisture: NA

CAS Number	Analyte	RL	Result
56-55-3	Benzo(a)anthracene	67	< 67 U
218-01-9	Chrysene	67	< 67 U
50-32-8	Benzo(a)pyrene	67	< 67 U
193-39-5	Indeno(1,2,3-cd)pyrene	67	< 67 U
53-70-3	Dibenz(a,h)anthracene	67	< 67 U
TOTBFA	Total Benzofluoranthenes	67	< 67 U

Reported in µg/kg (ppb)

Semivolatile Surrogate Recovery

d14-p-Terphenyl	85.6%
2-Fluorobiphenyl	68.4%

SW8270 PNA SURROGATE RECOVERY SUMMARY

Matrix: Soil

QC Report No: X006-Landau Associates, Inc.
Project: Kaiser IA
118033.100.104

<u>Client ID</u>	<u>TER</u>	<u>FBP</u>	<u>TOT OUT</u>
MB-111413	85.6%	68.4%	0
LCS-111413	84.0%	67.2%	0
LCSD-111413	81.2%	60.4%	0
SPL-64-20131114	57.2%	53.2%	0

	LCS/MB LIMITS	QC LIMITS
(TER) = d14-p-Terphenyl	(30-160)	(30-160)
(FBP) = 2-Fluorobiphenyl	(30-160)	(30-160)

Prep Method: SW3546
Log Number Range: 13-25187 to 13-25187

ORGANICS ANALYSIS DATA SHEET

PNAs by SW8270D GC/MS

Page 1 of 1

Sample ID: LCS-111413

LCS/LCSD

Lab Sample ID: LCS-111413

LIMS ID: 13-25187

Matrix: Soil

Data Release Authorized: 

Reported: 11/18/13

QC Report No: X006-Landau Associates, Inc.

Project: Kaiser IA

118033.100.104

Date Sampled: NA

Date Received: 11/14/13

Date Extracted LCS/LCSD: 11/14/13

Sample Amount LCS: 7.50 g-dry-wt

LCSD: 7.50 g-dry-wt

Date Analyzed LCS: 11/16/13 15:01

Final Extract Volume LCS: 0.50 mL

LCSD: 11/16/13 15:35

LCSD: 0.50 mL

Instrument/Analyst LCS: NT6/JZ

Dilution Factor LCS: 1.00

LCSD: NT6/JZ

LCSD: 1.00

GPC Cleanup: No

Alumina Cleanup: No

Silica Gel Cleanup: No

Analyte	Spike		LCS		Spike		LCSD	
	LCS	Added-LCS	Recovery	LCS	Added-LCSD	Recovery	RPD	
Benzo(a)anthracene	1450	1670	86.8%	1440	1670	86.2%	0.7%	
Chrysene	1430	1670	85.6%	1410	1670	84.4%	1.4%	
Benzo(a)pyrene	1570	1670	94.0%	1570	1670	94.0%	0.0%	
Indeno(1,2,3-cd)pyrene	1610	1670	96.4%	1580	1670	94.6%	1.9%	
Dibenz(a,h)anthracene	1610	1670	96.4%	1610	1670	96.4%	0.0%	
Total Benzofluoranthenes	2980	3330	89.5%	2950	3330	88.6%	1.0%	

Semivolatile Surrogate Recovery

	LCS	LCSD
d14-p-Terphenyl	84.0%	81.2%
2-Fluorobiphenyl	67.2%	60.4%

Results reported in µg/kg

RPD calculated using sample concentrations per SW846.

Waste Disposal Records

**APPENDIX G - TRUCK TONNAGE REPORT
INTERIM ACTION COMPLETION REPORT
SPENT POT LINING AREA
TACOMA, WASHINGTON**

Date Received at Waste Mangement	Recorded at Waste Management		Manifest/Disposal Certificate Information			Manifest Form (Y/N)	Weight Ticket (Y/N)	Disposal Certificate (Y/N)
	Weight (lbs)	Weight (tons)	Rcvd Date	Receipt #	Manifest #			
8/6/2013	1	61,860	30.93	1 8/6/2013	426983 010585319JJK	Y	Y	Y
	2	64,220	32.11	2 8/6/2013	426986 010585318JJK	Y	Y	Y
	3	64,540	32.27	3 8/6/2013	426989 010585317JJK	Y	Y	Y
	Total	190,620	95.31					
8/7/2013	1	61,380	30.69	1 8/7/2013	426993 010585328JJK	Y	Y	Y
	2	64,400	32.20	2 8/7/2013	426994 010585320JJK	Y	Y	Y
	3	60,180	30.09	3 8/7/2013	427011 010585326JJK	Y	Y	Y
	4	63,780	31.89	4 8/7/2013	427012 010585327JJK	Y	Y	Y
	5	64,160	32.08	5 8/7/2013	427013 010585325JJK	Y	Y	Y
	6	62,800	31.40	6 8/7/2013	427014 010585321JJK	Y	Y	Y
	7	63,640	31.82	7 8/7/2013	427015 010585324JJK	Y	Y	Y
	8	56,300	28.15	8 8/7/2013	427016 010585323JJK	Y	Y	Y
	9	65,180	32.59	9 8/7/2013	427017 010585322JJK	Y	Y	Y
	10	65,320	32.66	10 8/7/2013	427019 010585329JJK	Y	Y	Y
	11	66,140	33.07	11 8/7/2013	427020 010585336JJK	Y	Y	Y
	12	62,280	31.14	12 8/7/2013	427021 010585330JJK	Y	Y	Y
Total	755,560	377.78						
8/8/2013	1	63,540	31.77	1 8/8/2013	426988 010585316JJK	N	N	Y
	2	61,900	30.95	2 8/8/2013	427032 010585362JJK	Y	Y	Y
	3	64,500	32.25	3 8/8/2013	427033 010585361JJK	Y	Y	Y
	4	55,200	27.60	4 8/8/2013	427042 010585359JJK	Y	Y	Y
	5	67,520	33.76	5 8/8/2013	427043 010585363JJK	Y	Y	Y
	6	64,220	32.11	6 8/8/2013	427044 010585364JJK	Y	Y	Y
	7	63,140	31.57	7 8/8/2013	427045 010585353JJK	Y	Y	Y
	8	63,800	31.90	8 8/8/2013	427046 010585354JJK	Y	Y	Y
	9	73,220	36.61	9 8/8/2013	427047 010585357JJK	Y	Y	Y
	10	66,100	33.05	10 8/8/2013	427048 010585358JJK	Y	Y	Y
	11	63,840	31.92	11 8/8/2013	427050 010585356JJK	Y	Y	Y
Total	706,980	353.49						

**APPENDIX G - TRUCK TONNAGE REPORT
INTERIM ACTION COMPLETION REPORT
SPENT POT LINING AREA
TACOMA, WASHINGTON**

Date Received at Waste Management	Recorded at Waste Management		Manifest/Disposal Certificate Information			Manifest Form (Y/N)	Weight Ticket (Y/N)	Disposal Certificate (Y/N)
	Weight (lbs)	Weight (tons)	Rcvd Date	Receipt #	Manifest #			
8/9/2013	1	62,720	31.36	1 8/9/2013	427058 010585355JJK	Y	Y	Y
	2	65,460	32.73	2 8/9/2013	427073 010585351JJK	Y	Y	Y
	3	63,920	31.96	3 8/9/2013	427074 010585350JJK	Y	Y	Y
	4	65,400	32.70	4 8/9/2013	427076 010585352JJK	Y	Y	Y
	5	64,440	32.22	5 8/9/2013	427078 010585348JJK	Y	Y	Y
	6	67,260	33.63	6 8/9/2013	427079 010585334JJK	Y	Y	Y
	7	68,300	34.15	7 8/9/2013	427080 010585335JJK	Y	Y	Y
	8	63,400	31.70	8 8/9/2013	427081 010585349JJK	Y	Y	Y
	9	66,840	33.42	9 8/9/2013	427082 010585332JJK	Y	Y	Y
	10	64,120	32.06	10 8/9/2013	427084 010585333JJK	Y	Y	Y
	11	65,100	32.55	11 8/9/2013	427085 010585338JJK	Y	Y	Y
	12	68,040	34.02	12 8/9/2013	427086 010585331JJK	Y	Y	Y
	13	66,060	33.03	13 8/9/2013	427088 010585347JJK	Y	Y	Y
	14	66,540	33.27	14 8/9/2013	427089 010585337JJK	Y	Y	Y
Total	917,600	458.80						
8/12/2013	1	63,040	31.52	1 8/12/2013	427094 010585408JJK	Y	Y	Y
	2	61,300	30.65	2 8/12/2013	427095 010585409JJK	Y	Y	Y
	3	62,200	31.10	3 8/12/2013	427096 010585407JJK	Y	Y	Y
	4	60,080	30.04	4 8/12/2013	427098 010585410JJK	Y	Y	Y
	5	66,780	33.39	5 8/12/2013	427101 010585411JJK	Y	Y	Y
	6	68,260	34.13	6 8/12/2013	427107 010585418JJK	Y	Y	Y
	7	65,160	32.58	7 8/12/2013	427108 010585346JJK	Y	Y	Y
	8	67,040	33.52	8 8/12/2013	427109 010585412JJK	Y	Y	Y
	9	69,840	34.92	9 8/12/2013	427110 010585417JJK	Y	Y	Y
	10	66,560	33.28	10 8/12/2013	427111 010585419JJK	Y	Y	Y
	11	65,600	32.80	11 8/12/2013	427112 010585420JJK	Y	Y	Y
	12	63,620	31.81	12 8/12/2013	427113 010585406JJK	Y	Y	Y
	13	60,460	30.23	13 8/12/2013	427114 010585404JJK	Y	Y	Y
	14	65,660	32.83	14 8/12/2013	427115 010585405JJK	Y	Y	Y
Total	905,600	452.80						

**APPENDIX G - TRUCK TONNAGE REPORT
INTERIM ACTION COMPLETION REPORT
SPENT POT LINING AREA
TACOMA, WASHINGTON**

Date Received at Waste Management	Recorded at Waste Management		Manifest/Disposal Certificate Information			Manifest Form (Y/N)	Weight Ticket (Y/N)	Disposal Certificate (Y/N)
	Weight (lbs)	Weight (tons)	Rcvd Date	Receipt #	Manifest #			
8/13/2013	1	63,140	31.57	1 8/13/2013	427128 010585339JJK	Y	Y	Y
	2	64,380	32.19	2 8/13/2013	427129 010585340JJK	Y	Y	Y
	3	64,980	32.49	3 8/13/2013	427132 010585392JJK	Y	Y	Y
	4	70,400	35.20	4 8/13/2013	427133 010585345JJK	Y	Y	Y
	5	68,140	34.07	5 8/13/2013	427134 010585344JJK	Y	Y	Y
	6	65,420	32.71	6 8/13/2013	427135 010585403JJK	Y	Y	Y
	7	64,640	32.32	7 8/13/2013	427136 010585342JJK	Y	Y	Y
	8	64,680	32.34	8 8/13/2013	427141 010585343JJK	Y	Y	Y
	9	67,020	33.51	9 8/13/2013	427142 010585391JJK	Y	Y	Y
	10	66,380	33.19	10 8/13/2013	427143 010585390JJK	Y	Y	Y
	11	65,920	32.96	11 8/13/2013	427144 010585393JJK	Y	Y	Y
	12	58,860	29.43	12 8/13/2013	427145 010585394JJK	Y	Y	Y
	13	71,200	35.60	13 8/13/2013	427147 010585402JJK	Y	Y	Y
	14	63,700	31.85	14 8/13/2013	427148 010585395JJK	Y	Y	Y
Total	918,860	459.43						
8/14/2013	1	62,260	31.13	1 8/14/2013	427156 010585397JJK	Y	Y	Y
	2	65,820	32.91	2 8/14/2013	427168 010585396JJK	Y	Y	Y
	3	60,520	30.26	3 8/14/2013	427172 010585383JJK	Y	Y	Y
	4	60,520	30.26	4 8/14/2013	427173 010585388JJK	Y	Y	Y
	5	63,440	31.72	5 8/14/2013	427174 010585386JJK	Y	Y	Y
	6	57,400	28.70	6 8/14/2013	427175 010585387JJK	Y	Y	Y
	7	63,980	31.99	7 8/14/2013	427176 010585381JJK	Y	Y	Y
	8	66,420	33.21	8 8/14/2013	427178 010585380JJK	Y	Y	Y
	9	60,140	30.07	9 8/14/2013	427179 010585398JJK	Y	Y	Y
	10	67,860	33.93	10 8/14/2013	427185 010585382JJK	Y	Y	Y
	11	65,840	32.92	11 8/14/2013	427186 010585385JJK	Y	Y	Y
	12	68,280	34.14	12 8/14/2013	427187 010585401JJK	Y	Y	Y
	13	66,520	33.26	13 8/14/2013	427188 010585384JJK	Y	Y	Y
	14	66,900	33.45	14 8/14/2013	427189 010585400JJK	Y	Y	Y
	15	26,740	13.37	15 8/14/2013	427191 010585341JJK	Y	Y	Y
Total	922,640	461.32						

**APPENDIX G - TRUCK TONNAGE REPORT
 INTERIM ACTION COMPLETION REPORT
 SPENT POT LINING AREA
 TACOMA, WASHINGTON**

Date Received at Waste Mangement	Recorded at Waste Management		Manifest/Disposal Certificate Information			Manifest Form (Y/N)	Weight Ticket (Y/N)	Disposal Certificate (Y/N)
	Weight (lbs)	Weight (tons)	Rcvd Date	Receipt #	Manifest #			
8/15/2013	1	70,660	35.33	1 8/15/2013	427195 010585376JJK	Y	Y	Y
	2	62,900	31.45	2 8/15/2013	427211 010585375JJK	Y	Y	Y
	3	64,360	32.18	3 8/15/2013	427212 010585374JJK	Y	Y	Y
	4	64,940	32.47	4 8/15/2013	427213 010585373JJK	Y	Y	Y
	5	64,440	32.22	5 8/15/2013	427214 010585367JJK	Y	Y	Y
	6	66,020	33.01	6 8/15/2013	427215 010585372JJK	Y	Y	Y
	7	67,800	33.90	7 8/15/2013	427216 010585265JJK	Y	Y	Y
	8	65,440	32.72	8 8/15/2013	427217 010585389JJK	Y	Y	Y
	9	62,940	31.47	9 8/15/2013	427218 010585379JJK	Y	Y	Y
	10	62,560	31.28	10 8/15/2013	427219 010585399JJK	Y	Y	Y
	11	65,840	32.92	11 8/15/2013	427220 010585267JJK	Y	Y	Y
	12	65,300	32.65	12 8/15/2013	427222 010585378JJK	Y	Y	Y
	13	66,880	33.44	13 8/15/2013	427223 010585271JJK	Y	Y	Y
	14	68,580	34.29	14 8/15/2013	427224 010585270JJK	Y	Y	Y
	15	66,620	33.31	15 8/15/2013	427227 010585266JJK	Y	Y	Y
Total	985,280	492.64						
8/16/2013	1	66,320	33.16	1 8/16/2013	427240 010585269JJK	Y	Y	Y
	2	63,980	31.99	2 8/16/2013	427241 010585268JJK	Y	Y	Y
	3	64,080	32.04	3 8/16/2013	427243 010585377JJK	Y	Y	Y
	4	62,280	31.14	4 8/16/2013	427244 010585371JJK	Y	Y	Y
	5	66,220	33.11	5 8/16/2013	427245 010585370JJK	Y	Y	Y
	6	64,180	32.09	6 8/16/2013	427246 010585369JJK	Y	Y	Y
	7	67,120	33.56	7 8/16/2013	427247 010585368JJK	Y	Y	Y
	8	63,440	31.72	8 8/16/2013	427248 010585272JJK	Y	Y	Y
	9	65,200	32.60	9 8/16/2013	427249 010585273JJK	Y	Y	Y
	10	64,880	32.44	10 8/16/2013	427250 010585277JJK	Y	Y	Y
	11	63,080	31.54	11 8/16/2013	427251 010585276JJK	Y	Y	Y
	12	65,700	32.85	12 8/16/2013	427252 010585278JJK	Y	Y	Y
	13	65,600	32.80	13 8/16/2013	427253 010585280JJK	Y	Y	Y
	14	62,200	31.10	14 8/16/2013	427254 010585279JJK	Y	Y	Y

**APPENDIX G - TRUCK TONNAGE REPORT
 INTERIM ACTION COMPLETION REPORT
 SPENT POT LINING AREA
 TACOMA, WASHINGTON**

Date Received at Waste Mangement	Recorded at Waste Management		Manifest/Disposal Certificate Information			Manifest Form (Y/N)	Weight Ticket (Y/N)	Disposal Certificate (Y/N)
	Weight (lbs)	Weight (tons)	Rcvd Date	Receipt #	Manifest #			
Total	904,280	452.14						
8/19/2013	1	64,480	32.24	1 8/19/2013	427256 010585274JJK	Y	Y	Y
	2	64,420	32.21	2 8/19/2013	427259 011880504JJK	Y	Y	Y
	3	65,120	32.56	3 8/19/2013	427260 011880501JJK	Y	Y	Y
	4	64,640	32.32	4 8/19/2013	427261 011880503JJK	Y	Y	Y
	5	67,300	33.65	5 8/19/2013	427262 011880506JJK	Y	Y	Y
	6	67,120	33.56	6 8/19/2013	427263 011880505JJK	Y	Y	Y
	7	63,200	31.60	7 8/19/2013	427264 011880507JJK	Y	Y	Y
	8	61,720	30.86	8 8/19/2013	427265 011880509JJK	Y	Y	Y
	9	66,720	33.36	9 8/19/2013	427266 010585285JJK	Y	Y	Y
	10	63,300	31.65	10 8/19/2013	427267 010585284JJK	Y	Y	Y
	11	59,580	29.79	11 8/19/2013	427268 011880508JJK	Y	Y	Y
	12	54,260	27.13	12 8/19/2013	427269 011880502JJK	Y	Y	Y
	13	62,940	31.47	13 8/19/2013	427278 010585282JJK	Y	Y	Y
	14	62,820	31.41	14 8/19/2013	427280 010585281JJK	Y	Y	Y
	15	66,180	33.09	15 8/19/2013	427281 010585283JJK	Y	Y	Y
	16	66,740	33.37	16 8/19/2013	427283 011880523JJK	Y	Y	Y
	17	63,960	31.98	17 8/19/2013	427285 011880522JJK	Y	Y	Y
	18	61,660	30.83	18 8/19/2013	427286 011880521JJK	Y	Y	Y
	19	65,720	32.86	19 8/19/2013	427288 011880524JJK	Y	Y	Y
Total	1,211,880	605.94						

**APPENDIX G - TRUCK TONNAGE REPORT
 INTERIM ACTION COMPLETION REPORT
 SPENT POT LINING AREA
 TACOMA, WASHINGTON**

Date Received at Waste Mangement	Recorded at Waste Management		Manifest/Disposal Certificate Information			Manifest Form (Y/N)	Weight Ticket (Y/N)	Disposal Certificate (Y/N)
	Weight (lbs)	Weight (tons)	Rcvd Date	Receipt #	Manifest #			
8/20/2013	1	71,840	35.92	1 8/20/2013	427291 011880525JJK	Y	Y	Y
	2	64,800	32.40	2 8/20/2013	427302 011880511JJK	Y	Y	Y
	3	61,740	30.87	3 8/20/2013	427303 011880512JJK	Y	Y	Y
	4	68,340	34.17	4 8/20/2013	427304 011880510JJK	Y	Y	Y
	5	67,980	33.99	5 8/20/2013	427305 011880513JJK	Y	Y	Y
	6	65,780	32.89	6 8/20/2013	427306 011880514JJK	Y	Y	Y
	7	64,980	32.49	7 8/20/2013	427307 011880526JJK	Y	Y	Y
	8	68,120	34.06	8 8/20/2013	427310 010585275JJK	Y	Y	Y
	9	63,480	31.74	9 8/20/2013	427311 011880516JJK	Y	Y	Y
	10	65,880	32.94	10 8/20/2013	427312 011880515JJK	Y	Y	Y
	11	65,780	32.89	11 8/20/2013	427315 011880517JJK	Y	Y	Y
	12	66,280	33.14	12 8/20/2013	427316 011880518JJK	Y	Y	Y
	13	67,100	33.55	13 8/20/2013	427317 011880530JJK	Y	Y	Y
	14	63,780	31.89	14 8/20/2013	427320 011880529JJK	Y	Y	Y
	15	68,400	34.20	15 8/20/2013	427321 011880520JJK	Y	Y	Y
	16	70,380	35.19	16 8/20/2013	427322 011880519JJK	Y	Y	Y
	Total	1,064,660	532.33					

**APPENDIX G - TRUCK TONNAGE REPORT
 INTERIM ACTION COMPLETION REPORT
 SPENT POT LINING AREA
 TACOMA, WASHINGTON**

Date Received at Waste Mangement	Recorded at Waste Management		Manifest/Disposal Certificate Information			Manifest Form (Y/N)	Weight Ticket (Y/N)	Disposal Certificate (Y/N)
	Weight (lbs)	Weight (tons)	Rcvd Date	Receipt #	Manifest #			
8/21/2013	1	62,540	31.27	1 8/21/2013	427331 011880543JJK	Y	Y	Y
	2	62,100	31.05	2 8/21/2013	427347 011880545JJK	Y	Y	Y
	3	61,220	30.61	3 8/21/2013	427348 011880544JJK	Y	Y	Y
	4	63,220	31.61	4 8/21/2013	427349 011880555JJK	Y	Y	Y
	5	68,280	34.14	5 8/21/2013	427350 011880546JJK	Y	Y	Y
	6	67,960	33.98	6 8/21/2013	427351 011880547JJK	Y	Y	Y
	7	64,820	32.41	7 8/21/2013	427353 011880548JJK	Y	Y	Y
	8	63,320	31.66	8 8/21/2013	427354 011880541JJK	Y	Y	Y
	9	65,260	32.63	9 8/21/2013	427355 011880538JJK	Y	Y	Y
	10	58,800	29.40	10 8/21/2013	427356 011880549JJK	Y	Y	Y
	11	65,160	32.58	11 8/21/2013	427357 011880528JJK	Y	Y	Y
	12	66,140	33.07	12 8/21/2013	427358 011880539JJK	Y	Y	Y
	13	64,680	32.34	13 8/21/2013	427359 011880542JJK	Y	Y	Y
	14	64,960	32.48	14 8/21/2013	427361 011880537JJK	Y	Y	Y
	15	64,060	32.03	15 8/21/2013	427362 011880534JJK	Y	Y	Y
	16	69,480	34.74	16 8/21/2013	427363 011880535JJK	Y	Y	Y
	17	63,180	31.59	17 8/21/2013	427368 011880536JJK	Y	Y	Y
	18	67,020	33.51	18 8/21/2013	427369 011880531JJK	Y	Y	Y
	Total	1,162,200	581.10					

**APPENDIX G - TRUCK TONNAGE REPORT
INTERIM ACTION COMPLETION REPORT
SPENT POT LINING AREA
TACOMA, WASHINGTON**

Date Received at Waste Mangement	Recorded at Waste Management		Manifest/Disposal Certificate Information			Manifest Form (Y/N)	Weight Ticket (Y/N)	Disposal Certificate (Y/N)
	Weight (lbs)	Weight (tons)	Rcvd Date	Receipt #	Manifest #			
8/22/2013	1	68,740	34.37	1 8/22/2013	427381 011880583JJK	Y	Y	Y
	2	63,560	31.78	2 8/22/2013	427392 011880582JJK	Y	Y	Y
	3	63,620	31.81	3 8/22/2013	427393 011880581JJK	Y	Y	Y
	4	66,040	33.02	4 8/22/2013	427394 011880579JJK	Y	Y	Y
	5	60,800	30.40	5 8/22/2013	427395 011880580JJK	Y	Y	Y
	6	67,280	33.64	6 8/22/2013	427396 011880578JJK	Y	Y	Y
	7	68,260	34.13	7 8/22/2013	427397 011880576JJK	Y	Y	Y
	8	64,340	32.17	8 8/22/2013	427398 011880572JJK	Y	Y	Y
	9	64,520	32.26	9 8/22/2013	427399 011880574JJK			Y
	10	65,900	32.95	10 8/22/2013	427400 011880573JJK	Y	Y	Y
	11	58,060	29.03	11 8/22/2013	427401 011880577JJK	Y	Y	Y
	12	63,020	31.51	12 8/22/2013	427404 011880566JJK	Y	Y	Y
	13	62,520	31.26	13 8/22/2013	427405 011880569JJK	Y	Y	Y
	14	64,460	32.23	14 8/22/2013	427406 011880571JJK	Y	Y	Y
	15	64,940	32.47	15 8/22/2013	427407 011880570JJK	Y	Y	Y
	16	64,760	32.38	16 8/22/2013	427409 011880568JJK	Y	Y	Y
	17	65,980	32.99	17 8/22/2013	427412 011880567JJK	Y	Y	Y
	18	65,700	32.85	18 8/22/2013	427413 011880564JJK	Y	Y	Y
	19	60,380	30.19	19 8/22/2013	427414 011880565JJK	Y	Y	Y
	20	60,820	30.41	20 8/22/2013	427415 011880575JJK	Y	Y	Y
	Total	1,283,700	641.85					

**APPENDIX G - TRUCK TONNAGE REPORT
INTERIM ACTION COMPLETION REPORT
SPENT POT LINING AREA
TACOMA, WASHINGTON**

Date Received at Waste Mangement	Recorded at Waste Management		Manifest/Disposal Certificate Information			Manifest Form (Y/N)	Weight Ticket (Y/N)	Disposal Certificate (Y/N)
	Weight (lbs)	Weight (tons)	Rcvd Date	Receipt #	Manifest #			
8/23/2013	1	62,680	31.34	1 8/23/2013	427423 011880563JJK	Y	Y	Y
	2	55,180	27.59	2 8/23/2013	427429 011880562JJK	Y	Y	Y
	3	63,800	31.90	3 8/23/2013	427434 011880585JJK	Y	Y	Y
	4	65,540	32.77	4 8/23/2013	427435 011880588JJK	Y	Y	Y
	5	68,820	34.41	5 8/23/2013	427436 011880586JJK	Y	Y	Y
	6	64,160	32.08	6 8/23/2013	427437 011880592JJK	Y	Y	Y
	7	65,360	32.68	7 8/23/2013	427438 011880589JJK	Y	Y	Y
	8	65,480	32.74	8 8/23/2013	427439 011880587JJK	Y	Y	Y
	9	59,760	29.88	9 8/23/2013	427440 011880596JJK	Y	Y	Y
	10	65,180	32.59	10 8/23/2013	427441 011880602JJK	Y	Y	Y
	11	63,440	31.72	11 8/23/2013	427442 011880609JJK	Y	Y	Y
	12	64,720	32.36	12 8/23/2013	427443 011880594JJK	Y	Y	Y
	13	64,840	32.42	13 8/23/2013	427444 011880603JJK	Y	Y	Y
	14	68,160	34.08	14 8/23/2013	427445 011880598JJK	Y	Y	Y
	15	64,420	32.21	15 8/23/2013	427446 011880608JJK	Y	Y	Y
	16	67,240	33.62	16 8/23/2013	427447 011880606JJK	Y	Y	Y
	17	63,120	31.56	17 8/23/2013	427448 011880605JJK	Y	Y	Y
	18	64,900	32.45	18 8/23/2013	427449 011880600JJK	Y	Y	Y
	19	67,800	33.90	19 8/23/2013	427450 011880607JJK	Y	Y	Y
	20	66,180	33.09	20 8/23/2013	427451 011880604JJK	Y	Y	Y
	21	66,180	33.09	21 8/23/2013	427452 011880601JJK	Y	Y	Y
	22	66,380	33.19	22 8/23/2013	427453 011880595JJK	Y	Y	Y
	23	69,660	34.83	23 8/23/2013	427454 011880597JJK	Y	Y	Y
	24	66,240	33.12	24 8/23/2013	427455 011880599JJK	Y	Y	Y
Total		1,559,240	779.62					

**APPENDIX G - TRUCK TONNAGE REPORT
INTERIM ACTION COMPLETION REPORT
SPENT POT LINING AREA
TACOMA, WASHINGTON**

Date Received at Waste Mangement	Recorded at Waste Management		Manifest/Disposal Certificate Information			Manifest Form (Y/N)	Weight Ticket (Y/N)	Disposal Certificate (Y/N)
	Weight (lbs)	Weight (tons)	Rcvd Date	Receipt #	Manifest #			
8/26/2013	1	65,360	32.68	1 8/26/2013	427464 011880630JJK	Y	Y	Y
	2	65,240	32.62	2 8/26/2013	427465 011880631JJK	Y	Y	Y
	3	54,100	27.05	3 8/26/2013	427466 011880627JJK	Y	Y	Y
	4	62,560	31.28	4 8/26/2013	427467 011880629JJK	Y	Y	Y
	5	63,680	31.84	5 8/26/2013	427469 011880619JJK	Y	Y	Y
	6	59,280	29.64	6 8/26/2013	427470 011880626JJK	Y	Y	Y
	7	64,260	32.13	7 8/26/2013	427471 011880624JJK	Y	Y	Y
	8	60,820	30.41	8 8/26/2013	427472 011880620JJK	Y	Y	Y
	9	63,100	31.55	9 8/26/2013	427475 011880621JJK	Y	Y	Y
	10	65,860	32.93	10 8/26/2013	427477 011880625JJK	Y	Y	Y
	11	69,620	34.81	11 8/26/2013	427478 011880614JJK	Y	Y	Y
	12	65,960	32.98	12 8/26/2013	427479 011880628JJK	Y	Y	Y
	13	66,480	33.24	13 8/26/2013	427481 011880611JJK	Y	Y	Y
	14	68,500	34.25	14 8/26/2013	427482 011880610JJK	Y	Y	Y
	15	63,300	31.65	15 8/26/2013	427483 011880618JJK	Y	Y	Y
	16	67,520	33.76	16 8/26/2013	427484 011880617JJK	Y	Y	Y
	17	65,820	32.91	17 8/26/2013	427485 011880615JJK	Y	Y	Y
	18	66,060	33.03	18 8/26/2013	427486 011880593JJK	Y	Y	Y
	19	62,940	31.47	19 8/26/2013	427487 011880613JJK	Y	Y	Y
	20	65,560	32.78	20 8/26/2013	427488 011880612JJK	Y	Y	Y
	21	62,100	31.05	21 8/26/2013	427489 011880622JJK	Y	Y	Y
	22	63,340	31.67	22 8/26/2013	427490 011880623JJK	Y	Y	Y
	23	64,740	32.37	23 8/26/2013	427491 011880591JJK	Y	Y	Y
	Total	1,476,200	738.10					

**APPENDIX G - TRUCK TONNAGE REPORT
INTERIM ACTION COMPLETION REPORT
SPENT POT LINING AREA
TACOMA, WASHINGTON**

Date Received at Waste Mangement	Recorded at Waste Management		Manifest/Disposal Certificate Information			Manifest Form (Y/N)	Weight Ticket (Y/N)	Disposal Certificate (Y/N)
	Weight (lbs)	Weight (tons)	Rcvd Date	Receipt #	Manifest #			
8/27/2013	1	63,540	31.77	1 8/27/2013	427509 011880560JJK	Y	Y	Y
	2	66,960	33.48	2 8/27/2013	427510 011880559JJK	Y	Y	Y
	3	65,200	32.60	3 8/27/2013	427514 011880558JJK	Y	Y	Y
	4	62,780	31.39	4 8/27/2013	427515 011880556JJK	Y	Y	Y
	5	63,680	31.84	5 8/27/2013	427516 011880657JJK	Y	Y	Y
	6	62,500	31.25	6 8/27/2013	427517 011880647JJK	Y	Y	Y
	7	63,360	31.68	7 8/27/2013	427518 011880648JJK	Y	Y	Y
	8	60,100	30.05	8 8/27/2013	427521 011880646JJK	Y	Y	Y
	9	68,320	34.16	9 8/27/2013	427522 011880650JJK	Y	Y	Y
	10	66,380	33.19	10 8/27/2013	427523 011880653JJK	Y	Y	Y
	11	64,220	32.11	11 8/27/2013	427524 011880662JJK	Y	Y	Y
	12	66,560	33.28	12 8/27/2013	427525 011880640JJK	Y	Y	Y
	13	60,000	30.00	13 8/27/2013	427526 011880639JJK	Y	Y	Y
	14	64,840	32.42	14 8/27/2013	427527 011880616JJK	Y	Y	Y
	15	67,520	33.76	15 8/27/2013	427528 011880635JJK	Y	Y	Y
	16	67,180	33.59	16 8/27/2013	427529 011880641JJK	Y	Y	Y
	17	62,180	31.09	17 8/27/2013	427530 011880652JJK	Y	Y	Y
	18	64,540	32.27	18 8/27/2013	427531 011880660JJK	Y	Y	Y
	19	65,200	32.60	19 8/27/2013	427532 011880661JJK	Y	Y	Y
	20	68,280	34.14	20 8/27/2013	427533 011880664JJK	Y	Y	Y
	21	59,180	29.59	21 8/27/2013	427534 011880642JJK	Y	Y	Y
	22	62,920	31.46	22 8/27/2013	427536 011880671JJK	Y	Y	Y
	23	68,480	34.24	23 8/27/2013	427537 011880677JJK	Y	Y	Y
	24	61,800	30.90	24 8/27/2013	427538 011880680JJK	Y	Y	Y
	25	61,360	30.68	25 8/27/2013	427539 011880672JJK	Y	Y	Y
	26	65,680	32.84	26 8/27/2013	427540 011880634JJK	Y	Y	Y
	Total	1,672,760	836.38					

**APPENDIX G - TRUCK TONNAGE REPORT
 INTERIM ACTION COMPLETION REPORT
 SPENT POT LINING AREA
 TACOMA, WASHINGTON**

Date Received at Waste Mangement	Recorded at Waste Management		Manifest/Disposal Certificate Information			Manifest Form (Y/N)	Weight Ticket (Y/N)	Disposal Certificate (Y/N)
	Weight (lbs)	Weight (tons)	Rcvd Date	Receipt #	Manifest #			
8/28/2013	1	64,580	32.29	1 8/28/2013	427565 011880637JJK	Y	Y	Y
	2	65,520	32.76	2 8/28/2013	427566 011880668JJK	Y	Y	Y
	3	63,160	31.58	3 8/28/2013	427570 011880678JJK	Y	Y	Y
	4	63,360	31.68	4 8/28/2013	427571 011880669JJK	Y	Y	Y
	5	62,980	31.49	5 8/28/2013	427574 011880681JJK	Y	Y	Y
	6	63,860	31.93	6 8/28/2013	427576 011880684JJK	Y	Y	Y
	7	66,980	33.49	7 8/28/2013	427577 011880679JJK	Y	Y	Y
	8	64,040	32.02	8 8/28/2013	427579 011880675JJK	Y	Y	Y
	9	64,280	32.14	9 8/28/2013	427581 011880673JJK	Y	Y	Y
	10	61,400	30.70	10 8/28/2013	427583 011880670JJK	Y	Y	Y
	11	67,200	33.60	11 8/28/2013	427584 011880683JJK	Y	Y	Y
	12	61,960	30.98	12 8/28/2013	427585 011880674JJK	Y	Y	Y
	13	68,580	34.29	13 8/28/2013	427588 011880685JJK	Y	Y	Y
	14	63,940	31.97	14 8/28/2013	427590 011880686JJK	Y	Y	Y
	15	67,380	33.69	15 8/28/2013	427591 011880557JJK	Y	Y	Y
	Total	969,220	484.61					

**APPENDIX G - TRUCK TONNAGE REPORT
 INTERIM ACTION COMPLETION REPORT
 SPENT POT LINING AREA
 TACOMA, WASHINGTON**

Date Received at Waste Mangement	Recorded at Waste Management		Manifest/Disposal Certificate Information			Manifest Form	Weight Ticket	Disposal Certificate
	Weight (lbs)	Weight (tons)	Rcvd Date	Receipt #	Manifest #	(Y/N)	(Y/N)	(Y/N)
8/29/2013	1	66,020	33.01	1 8/29/2013	427597 011880687JJK	Y	Y	Y
	2	68,800	34.40	2 8/29/2013	427598 011880688JJK	Y	Y	Y
	3	64,600	32.30	3 8/29/2013	427609 010585291JJK	Y	Y	Y
	4	66,440	33.22	4 8/29/2013	427610 010585287JJK	Y	Y	Y
	5	61,880	30.94	5 8/29/2013	427612 010585288JJK	Y	Y	Y
	6	64,740	32.37	6 8/29/2013	427617 010585286JJK	Y	Y	Y
	7	65,680	32.84	7 8/29/2013	427618 010585296JJK	Y	Y	Y
	8	65,540	32.77	8 8/29/2013	427620 010585289JJK	Y	Y	Y
	9	66,360	33.18	9 8/29/2013	427621 010585295JJK	Y	Y	Y
	10	61,840	30.92	10 8/29/2013	427624 010585293JJK	Y	Y	Y
	11	66,860	33.43	11 8/29/2013	427625 010585301JJK	Y	Y	Y
	12	67,640	33.82	12 8/29/2013	427627 011880553JJK	Y	Y	Y
	13	63,700	31.85	13 8/29/2013	427628 010585294JJK	Y	Y	Y
	14	67,280	33.64	14 8/29/2013	427629 010585300JJK	Y	Y	Y
	15	62,180	31.09	15 8/29/2013	427630 010585299JJK	Y	Y	Y
	16	63,840	31.92	16 8/29/2013	427632 010585297JJK	Y	Y	Y
	17	61,540	30.77	17 8/29/2013	427633 010585298JJK	Y	Y	Y
	18	62,260	31.13	18 8/29/2013	427634 010585292JJK	Y	Y	Y
	19	66,120	33.06	19 8/29/2013	427637 010585290JJK	Y	Y	Y
	Total	1,233,320	616.66					

**APPENDIX G - TRUCK TONNAGE REPORT
INTERIM ACTION COMPLETION REPORT
SPENT POT LINING AREA
TACOMA, WASHINGTON**

Date Received at Waste Mangement	Recorded at Waste Management		Manifest/Disposal Certificate Information			Manifest Form (Y/N)	Weight Ticket (Y/N)	Disposal Certificate (Y/N)
	Weight (lbs)	Weight (tons)	Rcvd Date	Receipt #	Manifest #			
8/30/2013	1	67,580	33.79	1 8/30/2013	427646 010585305JJK	Y	Y	Y
	2	65,280	32.64	2 8/30/2013	427647 010585304JJK	Y	Y	Y
	3	66,000	33.00	3 8/30/2013	427650 010585302JJK	Y	Y	Y
	4	66,220	33.11	4 8/30/2013	427652 010585303JJK	Y	Y	Y
	5	64,880	32.44	5 8/30/2013	427656 011880533JJK	Y	Y	Y
	6	65,580	32.79	6 8/30/2013	427657 011880527JJK	Y	Y	Y
	7	63,120	31.56	7 8/30/2013	427658 011880532JJK	Y	Y	Y
	8	67,480	33.74	8 8/30/2013	427663 011880644JJK	Y	Y	Y
	9	66,280	33.14	9 8/30/2013	427665 011880584JJK	Y	Y	Y
	10	68,620	34.31	10 8/30/2013	427666 011880645JJK	Y	Y	Y
	11	64,380	32.19	11 8/30/2013	427667 011880590JJK	Y	Y	Y
	12	67,760	33.88	12 8/30/2013	427669 011880561JJK	Y	Y	Y
	13	71,640	35.82	13 8/30/2013	427670 011880643JJK	Y	Y	Y
	14	63,480	31.74	14 8/30/2013	427671 011880649JJK	Y	Y	Y
	15	58,320	29.16	15 8/30/2013	427672 011880655JJK	Y	Y	Y
	16	63,400	31.70	16 8/30/2013	427673 011880651JJK	Y	Y	Y
	17	66,120	33.06	17 8/30/2013	427674 011880654JJK	Y	Y	Y
Total	1,116,140	558.07						
9/3/2013	1	63,540	31.77	1 9/3/2013	427691 010585307JJK	Y	Y	Y
	2	63,720	31.86	2 9/3/2013	427692 011880554JJK	Y	Y	Y
	3	64,060	32.03	3 9/3/2013	427707 010585308JJK	Y	Y	Y
	4	67,000	33.50	4 9/3/2013	427709 010585312JJK	Y	Y	Y
	5	67,660	33.83	5 9/3/2013	427710 010585311JJK	Y	Y	Y
	6	61,140	30.57	6 9/3/2013	427711 010585306JJK	Y	Y	Y
	7	67,900	33.95	7 9/3/2013	427712 010585313JJK	Y	Y	Y
	8	62,720	31.36	8 9/3/2013	427713 010585310JJK	Y	Y	Y
	9	64,680	32.34	9 9/3/2013	427714 010585309JJK	Y	Y	Y
Total	582,420	291.21						

**APPENDIX G - TRUCK TONNAGE REPORT
INTERIM ACTION COMPLETION REPORT
SPENT POT LINING AREA
TACOMA, WASHINGTON**

Date Received at Waste Mangement	Recorded at Waste Management		Manifest/Disposal Certificate Information			Manifest Form (Y/N)	Weight Ticket (Y/N)	Disposal Certificate (Y/N)
	Weight (lbs)	Weight (tons)	Rcvd Date	Receipt #	Manifest #			
9/4/2013	1	67,460	33.73	1 9/4/2013	427743 010585314JJK	Y	Y	Y
	2	65,020	32.51	2 9/4/2013	427747 011880552JJK	Y	Y	Y
	3	64,640	32.32	3 9/4/2013	427756 011880705JJK	Y	Y	Y
	4	65,160	32.58	4 9/4/2013	427757 011880703JJK	Y	Y	Y
	5	61,920	30.96	5 9/4/2013	427759 011880704JJK	Y	Y	Y
	6	67,220	33.61	6 9/4/2013	427761 011880707JJK	Y	Y	Y
	7	61,560	30.78	7 9/4/2013	427762 011880706JJK	Y	Y	Y
	8	63,020	31.51	8 9/4/2013	427764 011880702JJK	Y	Y	Y
	9	64,140	32.07	9 9/4/2013	427770 011880692JJK	Y	Y	Y
	10	65,100	32.55	10 9/4/2013	427771 011880693JJK	Y	Y	Y
	11	67,560	33.78	11 9/4/2013	427773 011880696JJK	Y	Y	Y
	12	64,380	32.19	12 9/4/2013	427774 011880694JJK	Y	Y	Y
	13	66,160	33.08	13 9/4/2013	427775 011880699JJK	Y	Y	Y
	14	64,500	32.25	14 9/4/2013	427777 011880697JJK	Y	Y	Y
	15	59,060	29.53	15 9/4/2013	427778 011880698JJK	Y	Y	Y
	16	65,780	32.89	16 9/4/2013	427779 011880689JJK	Y	Y	Y
	17	62,580	31.29	17 9/4/2013	427780 011880700JJK	Y	Y	Y
	18	62,200	31.10	18 9/4/2013	427781 011880695JJK	Y	Y	Y
	19	61,900	30.95	19 9/4/2013	427782 011880701JJK	Y	Y	Y
	20	69,640	34.82	20 9/4/2013	427784 011880691JJK	Y	Y	Y
	Total	1,289,000	644.50					

**APPENDIX G - TRUCK TONNAGE REPORT
 INTERIM ACTION COMPLETION REPORT
 SPENT POT LINING AREA
 TACOMA, WASHINGTON**

Date Received at Waste Mangement	Recorded at Waste Management		Manifest/Disposal Certificate Information			Manifest Form (Y/N)	Weight Ticket (Y/N)	Disposal Certificate (Y/N)
	Weight (lbs)	Weight (tons)	Rcvd Date	Receipt #	Manifest #			
9/5/2013	1	68,280	34.14	1 9/5/2013	427801 011880708JJK	Y	Y	Y
	2	67,340	33.67	2 9/5/2013	427802 011880690JJK	Y	Y	Y
	3	65,080	32.54	3 9/5/2013	427811 011880712JJK	Y	Y	Y
	4	65,340	32.67	4 9/5/2013	427812 011880713JJK	Y	Y	Y
	5	66,640	33.32	5 9/5/2013	427813 011880715JJK	Y	Y	Y
	6	63,820	31.91	6 9/5/2013	427814 011880720JJK	Y	Y	Y
	7	61,860	30.93	7 9/5/2013	427816 011880722JJK	Y	Y	Y
	8	66,420	33.21	8 9/5/2013	427817 011880709JJK	Y	Y	Y
	9	64,860	32.43	9 9/5/2013	427818 011880716JJK	Y	Y	Y
	10	60,400	30.20	10 9/5/2013	427819 011880714JJK	Y	Y	Y
	11	66,540	33.27	11 9/5/2013	427821 011880721JJK	Y	Y	Y
	12	65,080	32.54	12 9/5/2013	427823 011880717JJK	Y	Y	Y
	13	66,700	33.35	13 9/5/2013	427824 011880719JJK	Y	Y	Y
	14	65,140	32.57	14 9/5/2013	427826 011880725JJK	Y	Y	Y
	15	61,500	30.75	15 9/5/2013	427827 011880711JJK	Y	Y	Y
	16	68,640	34.32	16 9/5/2013	427828 011880718JJK	Y	Y	Y
	17	68,540	34.27	17 9/5/2013	427829 011880723JJK	Y	Y	Y
	18	67,140	33.57	18 9/5/2013	427830 011880724JJK	Y	Y	Y
	19	64,440	32.22	19 9/5/2013	427831 011880710JJK	Y	Y	Y
	Total	1,243,760	621.88					

**APPENDIX G - TRUCK TONNAGE REPORT
 INTERIM ACTION COMPLETION REPORT
 SPENT POT LINING AREA
 TACOMA, WASHINGTON**

Date Received at Waste Mangement	Recorded at Waste Management		Manifest/Disposal Certificate Information			Manifest Form (Y/N)	Weight Ticket (Y/N)	Disposal Certificate (Y/N)
	Weight (lbs)	Weight (tons)	Rcvd Date	Receipt #	Manifest #			
9/6/2013	1	68,040	34.02	1 9/6/2013	427842 011880747JJK	Y	Y	Y
	2	66,680	33.34	2 9/6/2013	427844 011880748JJK	Y	Y	Y
	3	70,520	35.26	3 9/6/2013	427845 011880746JJK	Y	Y	Y
	4	66,140	33.07	4 9/6/2013	427847 011880750JJK	Y	Y	Y
	5	64,940	32.47	5 9/6/2013	427850 011880745JJK	Y	Y	Y
	6	62,020	31.01	6 9/6/2013	427851 011880744JJK	Y	Y	Y
	7	64,180	32.09	7 9/6/2013	427852 011880749JJK	Y	Y	Y
	8	65,240	32.62	8 9/6/2013	427854 011880741JJK	Y	Y	Y
	9	67,160	33.58	9 9/6/2013	427855 011880742JJK	Y	Y	Y
	10	64,840	32.42	10 9/6/2013	427856 011880743JJK	Y	Y	Y
	11	64,820	32.41	11 9/6/2013	427858 011880736JJK	Y	Y	Y
	12	64,400	32.20	12 9/6/2013	427864 011880735JJK	Y	Y	Y
	13	65,960	32.98	13 9/6/2013	427865 011880740JJK	Y	Y	Y
	14	67,880	33.94	14 9/6/2013	427866 011880737JJK	Y	Y	Y
	15	63,560	31.78	15 9/6/2013	427867 011880739JJK	Y	Y	Y
	16	57,680	28.84	16 9/6/2013	427868 011880738JJK	Y	Y	Y
	17	69,540	34.77	17 9/6/2013	427870 011880733JJK	Y	Y	Y
	18	68,180	34.09	18 9/6/2013	427871 011880734JJK	Y	Y	Y
	19	64,820	32.41	19 9/6/2013	427872 011880732JJK	Y	Y	Y
	Total	1,246,600	623.30					

**APPENDIX G - TRUCK TONNAGE REPORT
INTERIM ACTION COMPLETION REPORT
SPENT POT LINING AREA
TACOMA, WASHINGTON**

Date Received at Waste Mangement	Recorded at Waste Management		Manifest/Disposal Certificate Information			Manifest Form	Weight Ticket	Disposal Certificate
	Weight (lbs)	Weight (tons)	Rcvd Date	Receipt #	Manifest #	(Y/N)	(Y/N)	(Y/N)
9/9/2013	1	65,220	32.61	1 9/9/2013	427892 011870162JJK	Y	Y	Y
	2	65,160	32.58	2 9/9/2013	427893 011870163JJK	Y	Y	Y
	3	63,440	31.72	3 9/9/2013	427894 011870161JJK	Y	Y	Y
	4	65,120	32.56	4 9/9/2013	427896 011880729JJK	Y	Y	Y
	5	62,620	31.31	5 9/9/2013	427897 011870167JJK	Y	Y	Y
	6	68,540	34.27	6 9/9/2013	427898 011880727JJK	Y	Y	Y
	7	61,840	30.92	7 9/9/2013	427899 011870109JJK	Y	Y	Y
	8	62,060	31.03	8 9/9/2013	427900 011870166JJK	Y	Y	Y
	9	62,480	31.24	9 9/9/2013	427901 011880728JJK	Y	Y	Y
	10	58,940	29.47	10 9/9/2013	427907 011870168JJK	Y	Y	Y
	11	62,380	31.19	11 9/9/2013	427909 011880730JJK	Y	Y	Y
	12	62,280	31.14	12 9/9/2013	427910 011870164JJK	Y	Y	Y
	13	65,400	32.70	13 9/9/2013	427911 011870171JJK	Y	Y	Y
	14	65,060	32.53	14 9/9/2013	427912 011870103JJK	Y	Y	Y
	15	66,400	33.20	15 9/9/2013	427913 011870172JJK	Y	Y	Y
	16	60,460	30.23	16 9/9/2013	427914 011870108JJK	Y	Y	Y
	17	66,900	33.45	17 9/9/2013	427915 011870169JJK	Y	Y	Y
	18	67,900	33.95	18 9/9/2013	427916 011870165JJK	Y	Y	Y
	19	61,920	30.96	19 9/9/2013	427918 011870170JJK	Y	Y	Y
	20	64,680	32.34	20 9/9/2013	427920 011870107JJK	Y	Y	Y
	21	68,860	34.43	21 9/9/2013	427922 011870106JJK	Y	Y	Y
	22	67,300	33.65	22 9/9/2013	427923 011870105JJK	Y	Y	Y
	23	64,140	32.07	23 9/9/2013	427924 011870102JJK	Y	Y	Y
Total		1,479,100	739.55					

**APPENDIX G - TRUCK TONNAGE REPORT
INTERIM ACTION COMPLETION REPORT
SPENT POT LINING AREA
TACOMA, WASHINGTON**

Date Received at Waste Mangement	Recorded at Waste Management		Manifest/Disposal Certificate Information			Manifest Form (Y/N)	Weight Ticket (Y/N)	Disposal Certificate (Y/N)
	Weight (lbs)	Weight (tons)	Rcvd Date	Receipt #	Manifest #			
9/10/2013	1	64,260	32.13	1 9/10/2013	427940 011870100JJK	Y	Y	Y
	2	64,700	32.35	2 9/10/2013	427944 011870094JJK	Y	Y	Y
	3	66,040	33.02	3 9/10/2013	427946 011870093JJK	Y	Y	Y
	4	62,220	31.11	4 9/10/2013	427947 011870096JJK	Y	Y	Y
	5	64,640	32.32	5 9/10/2013	427948 011870091JJK	Y	Y	Y
	6	64,720	32.36	6 9/10/2013	427949 011870101JJK	Y	Y	Y
	7	62,500	31.25	7 9/10/2013	427951 011870095JJK	Y	Y	Y
	8	62,340	31.17	8 9/10/2013	427952 011870097JJK	Y	Y	Y
	9	70,280	35.14	9 9/10/2013	427953 011870087JJK	Y	Y	Y
	10	59,060	29.53	10 9/10/2013	427954 011870092JJK	Y	Y	Y
	11	63,960	31.98	11 9/10/2013	427956 011870084JJK	Y	Y	Y
	12	64,660	32.33	12 9/10/2013	427957 011870085JJK	Y	Y	Y
	13	66,460	33.23	13 9/10/2013	427958 011870083JJK	Y	Y	Y
	14	66,380	33.19	14 9/10/2013	427960 011870089JJK	Y	Y	Y
	15	62,040	31.02	15 9/10/2013	427961 011870090JJK	Y	Y	Y
	16	65,680	32.84	16 9/10/2013	427962 011870076JJK	Y	Y	Y
	17	63,140	31.57	17 9/10/2013	427963 011870072JJK	Y	Y	Y
	18	64,300	32.15	18 9/10/2013	427965 011870086JJK	Y	Y	Y
	19	68,260	34.13	19 9/10/2013	427966 011870073JJK	Y	Y	Y
	20	61,880	30.94	20 9/10/2013	427967 011870088JJK	Y	Y	Y
	21	59,540	29.77	21 9/10/2013	427968 011870075JJK	Y	Y	Y
	22	67,880	33.94	22 9/10/2013	427969 011870074JJK	Y	Y	Y
	23	63,040	31.52	23 9/10/2013	427971 011870077JJK	Y	Y	Y
	24	69,200	34.60	24 9/10/2013	427973 011870078JJK	Y	Y	Y
	25	65,760	32.88	25 9/10/2013	427974 011870080JJK	Y	Y	Y
	26	68,300	34.15	26 9/10/2013	427975 011870081JJK	Y	Y	Y
	27	60,760	30.38	27 9/10/2013	427976 011870082JJK	Y	Y	Y
	Total	1,742,000	871.00					

**APPENDIX G - TRUCK TONNAGE REPORT
INTERIM ACTION COMPLETION REPORT
SPENT POT LINING AREA
TACOMA, WASHINGTON**

Date Received at Waste Mangement	Recorded at Waste Management		Manifest/Disposal Certificate Information			Manifest Form (Y/N)	Weight Ticket (Y/N)	Disposal Certificate (Y/N)
	Weight (lbs)	Weight (tons)	Rcvd Date	Receipt #	Manifest #			
9/11/2013	1	62,980	31.49	1 9/11/2013	428002 011870079JJK	Y	Y	Y
	2	63,620	31.81	2 9/11/2013	428013 011870129JJK	Y	Y	Y
	3	63,460	31.73	3 9/11/2013	428016 011870132JJK	Y	Y	Y
	4	63,720	31.86	4 9/11/2013	428017 011870133JJK	Y	Y	Y
	5	63,100	31.55	5 9/11/2013	428018 011870128JJK	Y	Y	Y
	6	65,560	32.78	6 9/11/2013	428021 011870123JJK	Y	Y	Y
	7	63,200	31.60	7 9/11/2013	428022 011870130JJK	Y	Y	Y
	8	63,980	31.99	8 9/11/2013	428023 011870131JJK	Y	Y	Y
	9	64,000	32.00	9 9/11/2013	428025 011870124JJK	Y	Y	Y
	10	64,780	32.39	10 9/11/2013	428026 011870134JJK	Y	Y	Y
	11	58,200	29.10	11 9/11/2013	428027 011870122JJK	Y	Y	Y
	12	60,100	30.05	12 9/11/2013	428028 011870125JJK	Y	Y	Y
	13	67,180	33.59	13 9/11/2013	428029 011870120JJK	Y	Y	Y
	14	67,140	33.57	14 9/11/2013	428030 011870135JJK	Y	Y	Y
	15	68,260	34.13	15 9/11/2013	428032 011870121JJK	Y	Y	Y
	16	62,020	31.01	16 9/11/2013	428033 011870137JJK	Y	Y	Y
	17	63,980	31.99	17 9/11/2013	428034 011870127JJK	Y	Y	Y
	18	66,500	33.25	18 9/11/2013	428035 011870126JJK	Y	Y	Y
	19	67,880	33.94	19 9/11/2013	428036 011870136JJK	Y	Y	Y
	20	59,040	29.52	20 9/11/2013	428037 011870115JJK	Y	Y	Y
	21	63,520	31.76	21 9/11/2013	428038 011870119JJK	Y	Y	Y
	22	66,500	33.25	22 9/11/2013	428039 011870117JJK	Y	Y	Y
	23	67,560	33.78	23 9/11/2013	428040 011870116JJK	Y	Y	Y
	24	62,520	31.26	24 9/11/2013	428041 011870118JJK	Y	Y	Y
	25	71,140	35.57	25 9/11/2013	428043 011870114JJK	Y	Y	Y
	Total	1,609,940	804.97					

**APPENDIX G - TRUCK TONNAGE REPORT
INTERIM ACTION COMPLETION REPORT
SPENT POT LINING AREA
TACOMA, WASHINGTON**

Date Received at Waste Mangement	Recorded at Waste Management		Manifest/Disposal Certificate Information			Manifest Form (Y/N)	Weight Ticket (Y/N)	Disposal Certificate (Y/N)
	Weight (lbs)	Weight (tons)	Rcvd Date	Receipt #	Manifest #			
9/12/2013	1	61,580	30.79	1 9/12/2013	428066 011870138JJK	Y	Y	Y
	2	63,380	31.69	2 9/12/2013	428067 011870113JJK	Y	Y	Y
	3	70,960	35.48	3 9/12/2013	428074 011870112JJK	Y	Y	Y
	4	64,480	32.24	4 9/12/2013	428080 011870141JJK	Y	Y	Y
	5	62,620	31.31	5 9/12/2013	428081 011870142JJK	Y	Y	Y
	6	61,060	30.53	6 9/12/2013	428084 011870111JJK	Y	Y	Y
	7	65,940	32.97	7 9/12/2013	428085 011870143JJK	Y	Y	Y
	8	61,060	30.53	8 9/12/2013	428086 011870144JJK	Y	Y	Y
	9	65,300	32.65	9 9/12/2013	428089 011870146JJK	Y	Y	Y
	10	68,980	34.49	10 9/12/2013	428091 011870145JJK	Y	Y	Y
Total	645,360	322.68						
9/13/2013	1	67,560	33.78	1 9/13/2013	428107 011870139JJK	Y	Y	Y
	2	63,880	31.94	2 9/13/2013	428112 011870151JJK	Y	Y	Y
	3	63,260	31.63	3 9/13/2013	428113 011870150JJK	Y	Y	Y
	4	61,740	30.87	4 9/13/2013	428120 011870149JJK	Y	Y	Y
	5	63,160	31.58	5 9/13/2013	428122 011870154JJK	Y	Y	Y
	6	64,080	32.04	6 9/13/2013	428124 011870152JJK	Y	Y	Y
	7	64,640	32.32	7 9/13/2013	428126 011870153JJK	Y	Y	Y
	8	62,220	31.11	8 9/13/2013	428127 011870147JJK	Y	Y	Y
	9	67,300	33.65	9 9/13/2013	428128 011870148JJK	Y	Y	Y
	10	62,740	31.37	10 9/13/2013	428129 011870155JJK	Y	Y	Y
	11	68,920	34.46	11 9/13/2013	428132 011870156JJK	Y	Y	Y
Total	709,500	354.75						

**APPENDIX G - TRUCK TONNAGE REPORT
INTERIM ACTION COMPLETION REPORT
SPENT POT LINING AREA
TACOMA, WASHINGTON**

Date Received at Waste Mangement	Recorded at Waste Management		Manifest/Disposal Certificate Information			Manifest Form (Y/N)	Weight Ticket (Y/N)	Disposal Certificate (Y/N)
	Weight (lbs)	Weight (tons)	Rcvd Date	Receipt #	Manifest #			
9/16/2013	1	64,040	32.02	1 9/16/2013	428158 011870159JJK	Y	Y	Y
	2	63,660	31.83	2 9/16/2013	428159 011870158JJK	Y	Y	Y
	3	57,640	28.82	3 9/16/2013	428162 011870160JJK	Y	Y	Y
	4	62,960	31.48	4 9/16/2013	428165 011880892JJK	Y	Y	Y
	5	61,720	30.86	5 9/16/2013	428166 011880899JJK	Y	Y	Y
	6	61,760	30.88	6 9/16/2013	428167 011880897JJK	Y	Y	Y
	7	63,400	31.70	7 9/16/2013	428168 011870157JJK	Y	Y	Y
	8	65,260	32.63	8 9/16/2013	428169 011880898JJK	Y	Y	Y
	9	64,260	32.13	9 9/16/2013	428170 011880895JJK	Y	Y	Y
	10	65,680	32.84	10 9/16/2013	428171 011880896JJK	Y	Y	Y
	11	66,860	33.43	11 9/16/2013	428173 011880893JJK	Y	Y	Y
Total	697,240	348.62						
9/17/2013	1	64,140	32.07	1 9/17/2013	428206 011880894JJK	Y	Y	Y
	2	62,680	31.34	2 9/17/2013	428209 011880888JJK	Y	Y	Y
	3	64,900	32.45	3 9/17/2013	428210 011880890JJK	Y	Y	Y
	4	63,780	31.89	4 9/17/2013	428211 011880885JJK	Y	Y	Y
	5	63,440	31.72	5 9/17/2013	428213 011880868JJK	Y	Y	Y
	6	62,360	31.18	6 9/17/2013	428214 011880878JJK	Y	Y	Y
	7	64,520	32.26	7 9/17/2013	428217 011880882JJK	Y	Y	Y
	8	67,320	33.66	8 9/17/2013	428221 011880880JJK	Y	Y	Y
	9	65,080	32.54	9 9/17/2013	428222 011880877JJK	Y	Y	Y
	10	67,120	33.56	10 9/17/2013	428223 011880884JJK	Y	Y	Y
	11	66,640	33.32	11 9/17/2013	428224 011880879JJK	Y	Y	Y
	12	63,620	31.81	12 9/17/2013	428225 011880881JJK	Y	Y	Y
	13	70,640	35.32	13 9/17/2013	428226 011880883JJK	Y	Y	Y
	14	66,540	33.27	14 9/17/2013	428227 011880889JJK	Y	Y	Y
	15	66,200	33.10	15 9/17/2013	428228 011880886JJK	Y	Y	Y
	16	68,860	34.43	16 9/17/2013	428229 011880887JJK	Y	Y	Y
	17	64,740	32.37	17 9/17/2013	428230 011880891JJK	Y	Y	Y
Total	1,112,580	556.29						

**APPENDIX G - TRUCK TONNAGE REPORT
INTERIM ACTION COMPLETION REPORT
SPENT POT LINING AREA
TACOMA, WASHINGTON**

Date Received at Waste Mangement	Recorded at Waste Management		Manifest/Disposal Certificate Information			Manifest Form (Y/N)	Weight Ticket (Y/N)	Disposal Certificate (Y/N)
	Weight (lbs)	Weight (tons)	Rcvd Date	Receipt #	Manifest #			
9/18/2013	1	61,420	30.71	1 9/18/2013	428241 011880875JJK	Y	Y	Y
	2	35,160	17.58	2 9/18/2013	428253 011880876JJK	Y	Y	Y
	3	62,640	31.32	3 9/18/2013	428258 011880869JJK	Y	Y	Y
	4	61,400	30.70	4 9/18/2013	428259 011880867JJK	Y	Y	Y
	5	61,000	30.50	5 9/18/2013	428260 011880870JJK	Y	Y	Y
	6	66,640	33.32	6 9/18/2013	428262 011880866JJK	Y	Y	Y
	7	65,480	32.74	7 9/18/2013	428265 011880865JJK	Y	Y	Y
	8	66,320	33.16	8 9/18/2013	428267 011880864JJK	Y	Y	Y
	9	66,700	33.35	9 9/18/2013	428269 011880872JJK	Y	Y	Y
	10	64,780	32.39	10 9/18/2013	428271 011880871JJK	Y	Y	Y
	11	64,320	32.16	11 9/18/2013	428272 011880861JJK	Y	Y	Y
	12	65,720	32.86	12 9/18/2013	428274 011880873JJK	Y	Y	Y
	13	65,180	32.59	13 9/18/2013	428275 011880862JJK	Y	Y	Y
	14	65,120	32.56	14 9/18/2013	428276 011880863JJK	Y	Y	Y
	15	66,420	33.21	15 9/18/2013	428278 011880860JJK	Y	Y	Y
	16	67,280	33.64	16 9/18/2013	428280 011880874JJK	Y	Y	Y
	17	67,220	33.61	17 9/18/2013	428282 011880859JJK	Y	Y	Y
Total	1,072,800	536.40						
9/19/2013	1	62,820	31.41	1 9/19/2013	428299 011880854JJK	Y	Y	Y
	2	63,660	31.83	2 9/19/2013	428318 011880851JJK	Y	Y	Y
	3	65,200	32.60	3 9/19/2013	428319 011880853JJK	Y	Y	Y
	4	62,580	31.29	4 9/19/2013	428324 011880849JJK	Y	Y	Y
	5	64,360	32.18	5 9/19/2013	428325 011880852JJK	Y	Y	Y
	6	69,300	34.65	6 9/19/2013	428326 011880847JJK	Y	Y	Y
	7	67,920	33.96	7 9/19/2013	428327 011880856JJK	Y	Y	Y
	8	66,180	33.09	8 9/19/2013	428328 011880850JJK	Y	Y	Y
	9	65,000	32.50	9 9/19/2013	428330 011880848JJK	Y	Y	Y
	10	60,660	30.33	10 9/19/2013	428331 011880857JJK	Y	Y	Y
	11	66,980	33.49	11 9/19/2013	428336 011880855JJK	Y	Y	Y
	12	61,740	30.87	12 9/19/2013	428339 011880845JJK	Y	Y	Y
	13	62,740	31.37	13 9/19/2013	428340 011880858JJK	Y	Y	Y

**APPENDIX G - TRUCK TONNAGE REPORT
 INTERIM ACTION COMPLETION REPORT
 SPENT POT LINING AREA
 TACOMA, WASHINGTON**

Date Received at Waste Mangement	Recorded at Waste Management		Manifest/Disposal Certificate Information			Manifest Form (Y/N)	Weight Ticket (Y/N)	Disposal Certificate (Y/N)
	Weight (lbs)	Weight (tons)	Rcvd Date	Receipt #	Manifest #			
Total	839,140	419.57						
9/20/2013	1	63,760	31.88	1 9/20/2013	428359 011880844JJK	Y	Y	Y
	2	61,160	30.58	2 9/20/2013	428373 011880846JJK	Y	Y	Y
	3	64,640	32.32	3 9/20/2013	428374 011880837JJK	Y	Y	Y
	4	61,300	30.65	4 9/20/2013	428375 011880836JJK	Y	Y	Y
	5	66,320	33.16	5 9/20/2013	428377 011880838JJK	Y	Y	Y
	6	63,960	31.98	6 9/20/2013	428380 011880839JJK	Y	Y	Y
	7	67,100	33.55	7 9/20/2013	428385 011880842JJK	Y	Y	Y
	8	66,640	33.32	8 9/20/2013	428386 011880834JJK	Y	Y	Y
	9	61,860	30.93	9 9/20/2013	428387 011880835JJK	Y	Y	Y
	10	61,180	30.59	10 9/20/2013	428388 011880843JJK	Y	Y	Y
	11	63,260	31.63	11 9/20/2013	428389 011880841JJK	Y	Y	Y
	12	61,140	30.57	12 9/20/2013	428390 011880840JJK	Y	Y	Y
	13	65,200	32.60	13 9/20/2013	428393 011880831JJK	Y	Y	Y
	14	61,480	30.74	14 9/20/2013	428400 011880832JJK	Y	Y	Y
	15	66,960	33.48	15 9/20/2013	428406 011880833JJK	Y	Y	Y
Total	955,960	477.98						

**APPENDIX G - TRUCK TONNAGE REPORT
INTERIM ACTION COMPLETION REPORT
SPENT POT LINING AREA
TACOMA, WASHINGTON**

Date Received at Waste Mangement	Recorded at Waste Management		Manifest/Disposal Certificate Information			Manifest Form (Y/N)	Weight Ticket (Y/N)	Disposal Certificate (Y/N)
	Weight (lbs)	Weight (tons)	Rcvd Date	Receipt #	Manifest #			
9/23/2013	1	62,400	31.20	1 9/23/2013	428438 011880824JJK	Y	Y	Y
	2	65,920	32.96	2 9/23/2013	428440 011880822JJK	Y	Y	Y
	3	58,260	29.13	3 9/23/2013	428441 011880821JJK	Y	Y	Y
	4	63,640	31.82	4 9/23/2013	428442 011880820JJK	Y	Y	Y
	5	66,880	33.44	5 9/23/2013	428443 011880823JJK	Y	Y	Y
	6	66,020	33.01	6 9/23/2013	428446 011880818JJK	Y	Y	Y
	7	62,640	31.32	7 9/23/2013	428448 011880817JJK	Y	Y	Y
	8	66,280	33.14	8 9/23/2013	428449 011880815JJK	Y	Y	Y
	9	64,140	32.07	9 9/23/2013	428450 011880827JJK	Y	Y	Y
	10	57,380	28.69	10 9/23/2013	428451 011880819JJK	Y	Y	Y
	11	62,500	31.25	11 9/23/2013	428453 011880816JJK	Y	Y	Y
	12	62,860	31.43	12 9/23/2013	428455 011880828JJK	Y	Y	Y
	13	62,560	31.28	13 9/23/2013	428456 011880825JJK	Y	Y	Y
	14	61,460	30.73	14 9/23/2013	428457 011880826JJK	Y	Y	Y
	15	67,160	33.58	15 9/23/2013	428458 011880829JJK	Y	Y	Y
	16	66,700	33.35	16 9/23/2013	428459 011880813JJK	Y	Y	Y
	17	62,780	31.39	17 9/23/2013	428460 011880814JJK	Y	Y	Y
	18	66,080	33.04	18 9/23/2013	428461 011880812JJK	Y	Y	Y
	19	68,880	34.44	19 9/23/2013	428462 011880811JJK	Y	Y	Y
	20	65,540	32.77	20 9/23/2013	428464 011880810JJK	Y	Y	Y
	21	62,720	31.36	21 9/23/2013	428466 011880808JJK	Y	Y	Y
	22	68,860	34.43	22 9/23/2013	428467 011880809JJK	Y	Y	Y
	23	65,460	32.73	23 9/23/2013	428468 011880830JJK	Y	Y	Y
	24	65,380	32.69	24 9/23/2013	428471 011880800JJK	Y	Y	Y
	25	72,440	36.22	25 9/23/2013	428472 011880807JJK	Y	Y	Y
	Total	1,614,940	807.47					

**APPENDIX G - TRUCK TONNAGE REPORT
INTERIM ACTION COMPLETION REPORT
SPENT POT LINING AREA
TACOMA, WASHINGTON**

Date Received at Waste Mangement	Recorded at Waste Management		Manifest/Disposal Certificate Information			Manifest Form (Y/N)	Weight Ticket (Y/N)	Disposal Certificate (Y/N)
	Weight (lbs)	Weight (tons)	Rcvd Date	Receipt #	Manifest #			
9/24/2013	1	65,740	32.87	1 9/24/2013	428501 011880806JJK	Y	Y	Y
	2	66,920	33.46	2 9/24/2013	428502 011880803JJK	Y	Y	Y
	3	61,740	30.87	3 9/24/2013	428503 011880804JJK	Y	Y	Y
	4	66,500	33.25	4 9/24/2013	428504 011880805JJK	Y	Y	Y
	5	68,460	34.23	5 9/24/2013	428508 011880802JJK	Y	Y	Y
	6	61,940	30.97	6 9/24/2013	428509 011880801JJK	Y	Y	Y
	7	70,940	35.47	7 9/24/2013	428511 011880633JJK	Y	Y	Y
	8	66,760	33.38	8 9/24/2013	428512 011880632JJK	Y	Y	Y
	9	68,880	34.44	9 9/24/2013	428514 011880638JJK	Y	Y	Y
	10	66,720	33.36	10 9/24/2013	428515 011880663JJK	Y	Y	Y
	11	67,520	33.76	11 9/24/2013	428517 011880666JJK	Y	Y	Y
	12	66,620	33.31	12 9/24/2013	428518 011880665JJK	Y	Y	Y
	13	65,940	32.97	13 9/24/2013	428519 011880636JJK	Y	Y	Y
	14	63,820	31.91	14 9/24/2013	428520 011880658JJK	Y	Y	Y
	15	62,320	31.16	15 9/24/2013	428521 011880656JJK	Y	Y	Y
	16	61,640	30.82	16 9/24/2013	428522 011880659JJK	Y	Y	Y
	17	67,700	33.85	17 9/24/2013	428523 011880978JJK	Y	Y	Y
	18	62,620	31.31	18 9/24/2013	428527 011880667JJK	Y	Y	Y
	19	66,440	33.22	19 9/24/2013	428532 011880974JJK	Y	Y	Y
	20	63,700	31.85	20 9/24/2013	428533 011880975JJK	Y	Y	Y
	21	66,720	33.36	21 9/24/2013	428535 011880981JJK	Y	Y	Y
	22	68,260	34.13	22 9/24/2013	428539 011880976JJK	Y	Y	Y
	23	66,180	33.09	23 9/24/2013	428540 011880977JJK	Y	Y	Y
	Total	1,514,080	757.04					

**APPENDIX G - TRUCK TONNAGE REPORT
INTERIM ACTION COMPLETION REPORT
SPENT POT LINING AREA
TACOMA, WASHINGTON**

Date Received at Waste Management	Recorded at Waste Management		Manifest/Disposal Certificate Information			Manifest Form (Y/N)	Weight Ticket (Y/N)	Disposal Certificate (Y/N)
	Weight (lbs)	Weight (tons)	Rcvd Date	Receipt #	Manifest #			
9/25/2013	1	62,800	31.40	1 9/25/2013	428546 011880979JJK	Y	Y	Y
	2	68,680	34.34	2 9/25/2013	428547 011880980JJK	Y	Y	Y
	3	65,540	32.77	3 9/25/2013	428564 011880985JJK	Y	Y	Y
	4	70,140	35.07	4 9/25/2013	428565 011880990JJK	Y	Y	Y
	5	63,280	31.64	5 9/25/2013	428569 011880988JJK	Y	Y	Y
	6	62,840	31.42	6 9/25/2013	428570 011880989JJK	Y	Y	Y
	7	67,680	33.84	7 9/25/2013	428571 011880991JJK	Y	Y	Y
	8	67,320	33.66	8 9/25/2013	428574 011880986JJK	Y	Y	Y
	9	69,220	34.61	9 9/25/2013	428575 011880998JJK	Y	Y	Y
	10	57,980	28.99	10 9/25/2013	428576 011880982JJK	Y	Y	Y
	11	65,160	32.58	11 9/25/2013	428577 011880984JJK	Y	Y	Y
	12	64,920	32.46	12 9/25/2013	428578 011881000JJK	Y	Y	Y
	13	64,400	32.20	13 9/25/2013	428579 011880987JJK	Y	Y	Y
	14	61,320	30.66	14 9/25/2013	428580 011880983JJK	Y	Y	Y
	15	63,320	31.66	15 9/25/2013	428581 011880993JJK	Y	Y	Y
	16	62,320	31.16	16 9/25/2013	428582 011880996JJK	Y	Y	Y
	17	60,880	30.44	17 9/25/2013	428584 011880995JJK	Y	Y	Y
	18	65,420	32.71	18 9/25/2013	428586 011880973JJK	Y	Y	Y
	19	61,740	30.87	19 9/25/2013	428588 011880999JJK	Y	Y	Y
	20	67,620	33.81	20 9/25/2013	428591 011880992JJK	Y	Y	Y
	21	64,080	32.04	21 9/25/2013	428593 010585500JJK	Y	Y	Y
	22	62,280	31.14	22 9/25/2013	428594 011880972JJK	Y	Y	Y
	23	68,500	34.25	23 9/25/2013	428595 011880971JJK	Y	Y	Y
	24	57,580	28.79	24 9/25/2013	428596 011880970JJK	Y	Y	Y
	25	63,400	31.70	25 9/25/2013	428597 010585498JJK	Y	Y	Y
	26	67,280	33.64	26 9/25/2013	428599 011880969JJK	Y	Y	Y
	27	64,540	32.27	27 9/25/2013	428600 010585499JJK	Y	Y	Y
	Total	1,740,240	870.12					

**APPENDIX G - TRUCK TONNAGE REPORT
INTERIM ACTION COMPLETION REPORT
SPENT POT LINING AREA
TACOMA, WASHINGTON**

Date Received at Waste Mangement	Recorded at Waste Management		Manifest/Disposal Certificate Information			Manifest Form (Y/N)	Weight Ticket (Y/N)	Disposal Certificate (Y/N)
	Weight (lbs)	Weight (tons)	Rcvd Date	Receipt #	Manifest #			
9/26/2013	1	62,900	31.45	1 9/26/2013	428609 010585492JJK	Y	Y	Y
	2	68,880	34.44	2 9/26/2013	428611 010585497JJK	Y	Y	Y
	3	64,860	32.43	3 9/26/2013	428627 010585491JJK	Y	Y	Y
	4	61,640	30.82	4 9/26/2013	428628 010585489JJK	Y	Y	Y
	5	63,460	31.73	5 9/26/2013	428629 010585490JJK	Y	Y	Y
	6	65,620	32.81	6 9/26/2013	428630 010585494JJK	Y	Y	Y
	7	60,660	30.33	7 9/26/2013	428636 010585488JJK	Y	Y	Y
	8	64,440	32.22	8 9/26/2013	428637 010585493JJK	Y	Y	Y
	9	64,300	32.15	9 9/26/2013	428638 010585484JJK	Y	Y	Y
	10	62,280	31.14	10 9/26/2013	428639 010585482JJK	Y	Y	Y
	11	66,420	33.21	11 9/26/2013	428641 010585485JJK	Y	Y	Y
	12	55,360	27.68	12 9/26/2013	428642 010585496JJK	Y	Y	Y
	13	59,800	29.90	13 9/26/2013	428643 010585495JJK	Y	Y	Y
	14	65,340	32.67	14 9/26/2013	428644 010585487JJK	Y	Y	Y
	15	64,580	32.29	15 9/26/2013	428645 010585486JJK	Y	Y	Y
	16	66,960	33.48	16 9/26/2013	428646 010585480JJK	Y	Y	Y
	17	64,400	32.20	17 9/26/2013	428647 010585479JJK	Y	Y	Y
	18	60,160	30.08	18 9/26/2013	428648 010585483JJK	Y	Y	Y
	19	66,100	33.05	19 9/26/2013	428649 010585481JJK	Y	Y	Y
	20	64,880	32.44	20 9/26/2013	428650 010585478JJK	Y	Y	Y
	21	64,720	32.36	21 9/26/2013	428652 010585477JJK	Y	Y	Y
	22	65,060	32.53	22 9/26/2013	428653 010585476JJK	Y	Y	Y
	23	68,320	34.16	23 9/26/2013	428657 010585474JJK	Y	Y	Y
	24	73,780	36.89	24 9/26/2013	428658 010585475JJK	Y	Y	Y
	25	66,380	33.19	25 9/26/2013	428664 010585473JJK	Y	Y	Y
	Total	1,611,300	805.65					

**APPENDIX G - TRUCK TONNAGE REPORT
INTERIM ACTION COMPLETION REPORT
SPENT POT LINING AREA
TACOMA, WASHINGTON**

Date Received at Waste Mangement	Recorded at Waste Management		Manifest/Disposal Certificate Information			Manifest Form (Y/N)	Weight Ticket (Y/N)	Disposal Certificate (Y/N)
	Weight (lbs)	Weight (tons)	Rcvd Date	Receipt #	Manifest #			
9/27/2013	1	62180	31.09	1 9/27/2013	428668 010585470JJK	Y	Y	Y
	2	66980	33.49	2 9/27/2013	428670 010585454JJK	Y	Y	Y
	3	70380	35.19	3 9/27/2013	428675 010585469JJK	Y	Y	Y
	4	64500	32.25	4 9/27/2013	428681 010585459JJK	Y	Y	Y
	5	60240	30.12	5 9/27/2013	428682 010585467JJK	Y	Y	Y
	6	64320	32.16	6 9/27/2013	428687 010585456JJK	Y	Y	Y
	7	70140	35.07	7 9/27/2013	428689 010585462JJK	Y	Y	Y
	8	66660	33.33	8 9/27/2013	428690 010585455JJK	Y	Y	Y
	9	69740	34.87	9 9/27/2013	428691 010585466JJK	Y	Y	Y
	10	64760	32.38	10 9/27/2013	428692 010585463JJK	Y	Y	Y
	11	62520	31.26	11 9/27/2013	428694 010585447JJK	Y	Y	Y
	12	61100	30.55	12 9/27/2013	428695 010585471JJK	Y	Y	Y
	13	67160	33.58	13 9/27/2013	428697 010585457JJK	Y	Y	Y
	14	66540	33.27	14 9/27/2013	428698 010585468JJK	Y	Y	Y
	15	62520	31.26	15 9/27/2013	428699 010585449JJK	Y	Y	Y
	16	67700	33.85	16 9/27/2013	428700 010585464JJK	Y	Y	Y
	17	66220	33.11	17 9/27/2013	428701 010585446JJK	Y	Y	Y
	18	60560	30.28	18 9/27/2013	428702 010585448JJK	Y	Y	Y
	19	67700	33.85	19 9/27/2013	428703 010585445JJK	Y	Y	Y
	20	60460	30.23	20 9/27/2013	428704 010585465JJK	Y	Y	Y
	21	66200	33.1	21 9/27/2013	428705 010585472JJK	Y	Y	Y
	22	64100	32.05	22 9/27/2013	428706 010585450JJK	Y	Y	Y
	23	65320	32.66	23 9/27/2013	428710 010585460JJK	Y	Y	Y
	24	67740	33.87	24 9/27/2013	428711 010585458JJK	Y	Y	Y
	25	65700	32.85	25 9/27/2013	428713 010585451JJK	Y	Y	Y
	26	66720	33.36	26 9/27/2013	428714 010585461JJK	Y	Y	Y
	Total	1,698,160	849.08					

**APPENDIX G - TRUCK TONNAGE REPORT
 INTERIM ACTION COMPLETION REPORT
 SPENT POT LINING AREA
 TACOMA, WASHINGTON**

Date Received at Waste Mangement	Recorded at Waste Management		Manifest/Disposal Certificate Information			Manifest Form (Y/N)	Weight Ticket (Y/N)	Disposal Certificate (Y/N)
	Weight (lbs)	Weight (tons)	Rcvd Date	Receipt #	Manifest #			
9/30/2013	1	66,300	33.15	1 9/30/2013	428735 010585431JJK	Y	Y	Y
	2	67,380	33.69	2 9/30/2013	428736 010585432JJK	Y	Y	Y
	3	66,680	33.34	3 9/30/2013	428737 010585437JJK	Y	Y	Y
	4	63,820	31.91	4 9/30/2013	428740 010585436JJK	Y	Y	Y
	5	63,080	31.54	5 9/30/2013	428742 010585434JJK	Y	Y	Y
	6	61,980	30.99	6 9/30/2013	428743 010585442JJK	Y	Y	Y
	7	64,400	32.20	7 9/30/2013	428744 010585440JJK	Y	Y	Y
	8	69,420	34.71	8 9/30/2013	428745 010585438JJK	Y	Y	Y
	9	63,720	31.86	9 9/30/2013	428746 010585435JJK	Y	Y	Y
	10	72,120	36.06	10 9/30/2013	428747 010585441JJK	Y	Y	Y
	11	63,700	31.85	11 9/30/2013	428748 011886526JJK	Y	Y	Y
	12	65,440	32.72	12 9/30/2013	428749 010585439JJK	Y	Y	Y
	13	65,320	32.66	13 9/30/2013	428750 010585452JJK	Y	Y	Y
	14	69,100	34.55	14 9/30/2013	428751 010585444JJK	Y	Y	Y
	15	66,280	33.14	15 9/30/2013	428752 011886514JJK	Y	Y	Y
	16	61,380	30.69	16 9/30/2013	428754 011886515JJK	Y	Y	Y
	17	66,240	33.12	17 9/30/2013	428763 010585443JJK	Y	Y	Y
	Total	1,116,360	558.18					

**APPENDIX G - TRUCK TONNAGE REPORT
INTERIM ACTION COMPLETION REPORT
SPENT POT LINING AREA
TACOMA, WASHINGTON**

Date Received at Waste Mangement	Recorded at Waste Management		Manifest/Disposal Certificate Information			Manifest Form (Y/N)	Weight Ticket (Y/N)	Disposal Certificate (Y/N)	
	Weight (lbs)	Weight (tons)	Rcvd Date	Receipt #	Manifest #				
10/1/2013	1	64,940	32.47	1	10/1/2013	428783 011886506JJK	Y	Y	Y
	2	63,600	31.80	2	10/1/2013	428784 011886501JJK	Y	Y	Y
	3	64,980	32.49	3	10/1/2013	428785 011886503JJK	Y	Y	Y
	4	63,700	31.85	4	10/1/2013	428787 010585427JJK	Y	Y	Y
	5	64,380	32.19	5	10/1/2013	428788 011886524JJK	Y	Y	Y
	6	62,680	31.34	6	10/1/2013	428789 011886504JJK	Y	Y	Y
	7	71,280	35.64	7	10/1/2013	428790 010585428JJK	Y	Y	Y
	8	63,440	31.72	8	10/1/2013	428792 011886523JJK	Y	Y	Y
	9	62,480	31.24	9	10/1/2013	428798 011886525JJK	Y	Y	Y
	10	63,020	31.51	10	10/1/2013	428799 010585430JJK	Y	Y	Y
	11	59,620	29.81	11	10/1/2013	428800 010585429JJK	Y	Y	Y
	12	68,560	34.28	12	10/1/2013	428802 011886502JJK	Y	Y	Y
	13	64,360	32.18	13	10/1/2013	428804 011886508JJK	Y	Y	Y
	14	62,180	31.09	14	10/1/2013	428806 011886518JJK	Y	Y	Y
	15	70,120	35.06	15	10/1/2013	428807 011886519JJK	Y	Y	Y
	16	65,660	32.83	16	10/1/2013	428809 011886522JJK	Y	Y	Y
	17	69,280	34.64	17	10/1/2013	428810 011886521JJK	Y	Y	Y
	18	62,620	31.31	18	10/1/2013	428812 011886507JJK	Y	Y	Y
	19	66,760	33.38	19	10/1/2013	428813 011886517JJK	Y	Y	Y
	20	61,520	30.76	20	10/1/2013	428815 011886798JJK	Y	Y	Y
	21	61,200	30.60	21	10/1/2013	428817 011886797JJK	Y	Y	Y
	22	68,720	34.36	22	10/1/2013	428819 011886520JJK	Y	Y	Y
	Total	1,425,100	712.55						

**APPENDIX G - TRUCK TONNAGE REPORT
INTERIM ACTION COMPLETION REPORT
SPENT POT LINING AREA
TACOMA, WASHINGTON**

Date Received at Waste Mangement	Recorded at Waste Management		Manifest/Disposal Certificate Information			Manifest Form (Y/N)	Weight Ticket (Y/N)	Disposal Certificate (Y/N)
	Weight (lbs)	Weight (tons)	Rcvd Date	Receipt #	Manifest #			
10/2/2013	1	63,800	31.90	1 10/2/2013	428843 011886533JJK	Y	Y	Y
	2	66,600	33.30	2 10/2/2013	428848 011886547JJK	Y	Y	Y
	3	63,460	31.73	3 10/2/2013	428849 011886549JJK	Y	Y	Y
	4	62,000	31.00	4 10/2/2013	428850 011886530JJK	Y	Y	Y
	5	65,040	32.52	5 10/2/2013	428851 011886528JJK	Y	Y	Y
	6	68,640	34.32	6 10/2/2013	428852 011886529JJK	Y	Y	Y
	7	63,480	31.74	7 10/2/2013	428853 011886531JJK	Y	Y	Y
	8	66,180	33.09	8 10/2/2013	428854 011886543JJK	Y	Y	Y
	9	64,100	32.05	9 10/2/2013	428856 011886548JJK	Y	Y	Y
	10	62,700	31.35	10 10/2/2013	428857 011886540JJK	Y	Y	Y
	11	64,080	32.04	11 10/2/2013	428858 011886542JJK	Y	Y	Y
	12	61,580	30.79	12 10/2/2013	428859 011886539JJK	Y	Y	Y
	13	68,540	34.27	13 10/2/2013	428860 011886545JJK	Y	Y	Y
	14	67,220	33.61	14 10/2/2013	428862 011886538JJK	Y	Y	Y
	15	69,140	34.57	15 10/2/2013	428863 011886544JJK	Y	Y	Y
	16	68,220	34.11	16 10/2/2013	428865 011886546JJK	Y	Y	Y
	17	70,560	35.28	17 10/2/2013	428866 011886537JJK	Y	Y	Y
	18	66,000	33.00	18 10/2/2013	428867 011886536JJK	Y	Y	Y
	19	65,560	32.78	19 10/2/2013	428868 011886532JJK	Y	Y	Y
	20	65,700	32.85	20 10/2/2013	428871 011886541JJK	Y	Y	Y
	21	67,820	33.91	21 10/2/2013	428874 011886534JJK	Y	Y	Y
	22	66,380	33.19	22 10/2/2013	428875 011886559JJK	Y	Y	Y
	23	67,040	33.52	23 10/2/2013	428876 011886535JJK	Y	Y	Y
	24	59,420	29.71	24 10/2/2013	428879 011886527JJK	Y	Y	Y
	Total	1,573,260	786.63					

**APPENDIX G - TRUCK TONNAGE REPORT
INTERIM ACTION COMPLETION REPORT
SPENT POT LINING AREA
TACOMA, WASHINGTON**

Date Received at Waste Mangement	Recorded at Waste Management		Manifest/Disposal Certificate Information			Manifest Form (Y/N)	Weight Ticket (Y/N)	Disposal Certificate (Y/N)
	Weight (lbs)	Weight (tons)	Rcvd Date	Receipt #	Manifest #			
10/3/2013	1	69,240	34.62	1 10/3/2013	428894 011886516JJK	Y	Y	Y
	2	64,420	32.21	2 10/3/2013	428904 011886557JJK	Y	Y	Y
	3	63,640	31.82	3 10/3/2013	428905 011886558JJK	Y	Y	Y
	4	62,560	31.28	4 10/3/2013	428906 011886575JJK	Y	Y	Y
	5	60,240	30.12	5 10/3/2013	428907 011886571JJK	Y	Y	Y
	6	61,520	30.76	6 10/3/2013	428908 011886573JJK	Y	Y	Y
	7	64,540	32.27	7 10/3/2013	428911 011886578JJK	Y	Y	Y
	8	61,260	30.63	8 10/3/2013	428913 011886574JJK	Y	Y	Y
	9	64,620	32.31	9 10/3/2013	428914 011886576JJK	Y	Y	Y
	10	66,480	33.24	10 10/3/2013	428915 011886572JJK	Y	Y	Y
	11	67,700	33.85	11 10/3/2013	428917 011886561JJK	Y	Y	Y
	12	62,620	31.31	12 10/3/2013	428919 011886577JJK	Y	Y	Y
	13	61,300	30.65	13 10/3/2013	428920 011886560JJK	Y	Y	Y
	14	65,720	32.86	14 10/3/2013	428921 011886556JJK	Y	Y	Y
	15	68,860	34.43	15 10/3/2013	428922 011886562JJK	Y	Y	Y
	16	61,460	30.73	16 10/3/2013	428923 011886555JJK	Y	Y	Y
	17	63,900	31.95	17 10/3/2013	428927 011886553JJK	Y	Y	Y
	18	67,740	33.87	18 10/3/2013	428930 011886563JJK	Y	Y	Y
	19	63,020	31.51	19 10/3/2013	428931 011886550JJK	Y	Y	Y
	20	57,220	28.61	20 10/3/2013	428932 011886564JJK	Y	Y	Y
	21	66,620	33.31	21 10/3/2013	428934 011886554JJK	Y	Y	Y
	22	68,300	34.15	22 10/3/2013	428936 011886552JJK	Y	Y	Y
	23	65,020	32.51	23 10/3/2013	428937 011886551JJK	Y	Y	Y
	24	67,560	33.78	24 10/3/2013	428938 011886565JJK	Y	Y	Y
	Total	1,545,560	772.78					

**APPENDIX G - TRUCK TONNAGE REPORT
INTERIM ACTION COMPLETION REPORT
SPENT POT LINING AREA
TACOMA, WASHINGTON**

Date Received at Waste Mangement	Recorded at Waste Management		Manifest/Disposal Certificate Information			Manifest Form (Y/N)	Weight Ticket (Y/N)	Disposal Certificate (Y/N)
	Weight (lbs)	Weight (tons)	Rcvd Date	Receipt #	Manifest #			
10/4/2013	1	65,120	32.56	1 10/4/2013	428961 011886570JJK	Y	Y	Y
	2	61,780	30.89	2 10/4/2013	428962 011886569JJK	Y	Y	Y
	3	63,780	31.89	3 10/4/2013	428963 011886589JJK	Y	Y	Y
	4	64,180	32.09	4 10/4/2013	428964 011886593JJK	Y	Y	Y
	5	65,500	32.75	5 10/4/2013	428965 011886588JJK	Y	Y	Y
	6	65,480	32.74	6 10/4/2013	428966 011886595JJK	Y	Y	Y
	7	64,860	32.43	7 10/4/2013	428969 011886585JJK	Y	Y	Y
	8	67,360	33.68	8 10/4/2013	428973 011886586JJK	Y	Y	Y
	9	66,160	33.08	9 10/4/2013	428975 011886583JJK	Y	Y	Y
	10	62,160	31.08	10 10/4/2013	428976 011886587JJK	Y	Y	Y
	11	60,740	30.37	11 10/4/2013	428977 011886592JJK	Y	Y	Y
	12	63,740	31.87	12 10/4/2013	428978 011886594JJK	Y	Y	Y
	13	69,620	34.81	13 10/4/2013	428981 011886590JJK	Y	Y	Y
	14	61,780	30.89	14 10/4/2013	428982 011886785JJK	Y	Y	Y
	15	66,280	33.14	15 10/4/2013	428983 011886582JJK	Y	Y	Y
	16	66,860	33.43	16 10/4/2013	428984 011886591JJK	Y	Y	Y
	17	62,980	31.49	17 10/4/2013	428986 011886584JJK	Y	Y	Y
	18	65,200	32.60	18 10/4/2013	428987 011886581JJK	Y	Y	Y
	19	65,620	32.81	19 10/4/2013	428988 011886579JJK	Y	Y	Y
	20	74,140	37.07	20 10/4/2013	428989 011886580JJK	Y	Y	Y
	21	62,320	31.16	21 10/4/2013	428990 011886567JJK	Y	Y	Y
	22	69,780	34.89	22 10/4/2013	428992 011886566JJK	Y	Y	Y
	23	63,300	31.65	23 10/4/2013	428993 011886568JJK	Y	Y	Y
	Total	1,498,740	749.37					

**APPENDIX G - TRUCK TONNAGE REPORT
INTERIM ACTION COMPLETION REPORT
SPENT POT LINING AREA
TACOMA, WASHINGTON**

Date Received at Waste Mangement	Recorded at Waste Management			Manifest/Disposal Certificate Information			Manifest Form (Y/N)	Weight Ticket (Y/N)	Disposal Certificate (Y/N)
	Weight (lbs)	Weight (tons)		Rcvd Date	Receipt #	Manifest #			
10/7/2013	1	63,200	31.60	1 10/7/2013	429010	011886774JJK	Y	Y	Y
	2	65,420	32.71	2 10/7/2013	429011	011886794JJK	Y	Y	Y
	3	64,160	32.08	3 10/7/2013	429015	011886773JJK	Y	Y	Y
	4	64,440	32.22	4 10/7/2013	429016	011886792JJK	Y	Y	Y
	5	64,160	32.08	5 10/7/2013	429017	011886775JJK	Y	Y	Y
	6	63,900	31.95	6 10/7/2013	429018	011886795JJK	Y	Y	Y
	7	70,480	35.24	7 10/7/2013	429019	011886772JJK	Y	Y	Y
	8	64,260	32.13	8 10/7/2013	429020	011886796JJK	Y	Y	Y
	9	59,940	29.97	9 10/7/2013	429022	011886770JJK	Y	Y	Y
	10	67,140	33.57	10 10/7/2013	429023	011886771JJK	Y	Y	Y
	11	68,260	34.13	11 10/7/2013	429024	011886791JJK	Y	Y	Y
	12	61,360	30.68	12 10/7/2013	429025	011886787JJK	Y	Y	Y
	13	65,100	32.55	13 10/7/2013	429029	011886786JJK	Y	Y	Y
	14	64,880	32.44	14 10/7/2013	429034	011886788JJK	Y	Y	Y
	15	65,440	32.72	15 10/7/2013	429035	011886778JJK	Y	Y	Y
	16	64,280	32.14	16 10/7/2013	429036	011886790JJK	Y	Y	Y
	17	69,080	34.54	17 10/7/2013	429039	011886782JJK	Y	Y	Y
	18	70,180	35.09	18 10/7/2013	429041	011886789JJK	Y	Y	Y
	19	64,780	32.39	19 10/7/2013	429042	011886784JJK	Y	Y	Y
	20	71,280	35.64	20 10/7/2013	429044	011886777JJK	Y	Y	Y
	21	70,020	35.01	21 10/7/2013	429046	011886776JJK	Y	Y	Y
	22	65,340	32.67	22 10/7/2013	429047	011886783JJK	Y	Y	Y
	Total	1,447,100	723.55						

**APPENDIX G - TRUCK TONNAGE REPORT
INTERIM ACTION COMPLETION REPORT
SPENT POT LINING AREA
TACOMA, WASHINGTON**

Date Received at Waste Mangement	Recorded at Waste Management		Manifest/Disposal Certificate Information			Manifest Form (Y/N)	Weight Ticket (Y/N)	Disposal Certificate (Y/N)	
	Weight (lbs)	Weight (tons)	Rcvd Date	Receipt #	Manifest #				
10/8/2013	1	61,860	30.93	1	10/8/2013	429055 011886793JJK	Y	Y	Y
	2	64,520	32.26	2	10/8/2013	429068 011886729JJK	Y	Y	Y
	3	64,000	32.00	3	10/8/2013	429069 011886730JJK	Y	Y	Y
	4	67,200	33.60	4	10/8/2013	429070 011886728JJK	Y	Y	Y
	5	63,420	31.71	5	10/8/2013	429072 011886726JJK	Y	Y	Y
	6	64,800	32.40	6	10/8/2013	429073 011886732JJK	Y	Y	Y
	7	69,380	34.69	7	10/8/2013	429076 011886733JJK	Y	Y	Y
	8	62,800	31.40	8	10/8/2013	429077 011886734JJK	Y	Y	Y
	9	63,040	31.52	9	10/8/2013	429078 011886738JJK	Y	Y	Y
	10	63,360	31.68	10	10/8/2013	429079 011886736JJK	Y	Y	Y
	11	64,960	32.48	11	10/8/2013	429080 011886739JJK	Y	Y	Y
	12	65,680	32.84	12	10/8/2013	429082 011886735JJK	Y	Y	Y
	13	64,560	32.28	13	10/8/2013	429083 011886727JJK	Y	Y	Y
	14	68,820	34.41	14	10/8/2013	429084 011886731JJK	Y	Y	Y
	15	66,180	33.09	15	10/8/2013	429087 011886737JJK	Y	Y	Y
	16	71,780	35.89	16	10/8/2013	429092 011886740JJK	Y	Y	Y
	17	61,540	30.77	17	10/8/2013	429093 011886741JJK	Y	Y	Y
	18	67,260	33.63	18	10/8/2013	429094 011886742JJK	Y	Y	Y
	19	60,000	30.00	19	10/8/2013	429095 011886744JJK	Y	Y	Y
	20	66,780	33.39	20	10/8/2013	429096 011886743JJK	Y	Y	Y
	Total	1,301,940	650.97						

**APPENDIX G - TRUCK TONNAGE REPORT
 INTERIM ACTION COMPLETION REPORT
 SPENT POT LINING AREA
 TACOMA, WASHINGTON**

Date Received at Waste Mangement	Recorded at Waste Management		Manifest/Disposal Certificate Information			Manifest Form (Y/N)	Weight Ticket (Y/N)	Disposal Certificate (Y/N)	
	Weight (lbs)	Weight (tons)	Rcvd Date	Receipt #	Manifest #				
10/9/2013	1	61,500	30.75	1	10/9/2013	429105 011886725JJK	Y	Y	Y
	2	66,300	33.15	2	10/9/2013	429130 011886749JJK	Y	Y	Y
	3	64,320	32.16	3	10/9/2013	429131 011886747JJK	Y	Y	Y
	4	62,360	31.18	4	10/9/2013	429132 011886748JJK	Y	Y	Y
	5	60,460	30.23	5	10/9/2013	429136 011886751JJK	Y	Y	Y
	6	63,020	31.51	6	10/9/2013	429137 011886754JJK	Y	Y	Y
	7	64,080	32.04	7	10/9/2013	429140 011886753JJK	Y	Y	Y
	8	66,140	33.07	8	10/9/2013	429141 011886750JJK	Y	Y	Y
	9	67,080	33.54	9	10/9/2013	429142 011886746JJK	Y	Y	Y
	10	67,080	33.54	10	10/9/2013	429144 011886752JJK	Y	Y	Y
	11	71,660	35.83	11	10/9/2013	429145 011886756JJK	Y	Y	Y
	12	62,760	31.38	12	10/9/2013	429148 011886745JJK	Y	Y	Y
	13	67,860	33.93	13	10/9/2013	429149 011886755JJK	Y	Y	Y
	14	67,600	33.80	14	10/9/2013	429153 011886761JJK	Y	Y	Y
	15	67,260	33.63	15	10/9/2013	429154 011886759JJK	Y	Y	Y
	16	63,160	31.58	16	10/9/2013	429161 011886757JJK	Y	Y	Y
	17	67,560	33.78	17	10/9/2013	429162 011886758JJK	Y	Y	Y
	18	58,080	29.04	18	10/9/2013	429163 011886760JJK	Y	Y	Y
	Total	1,168,280	584.14						

**APPENDIX G - TRUCK TONNAGE REPORT
 INTERIM ACTION COMPLETION REPORT
 SPENT POT LINING AREA
 TACOMA, WASHINGTON**

Date Received at Waste Mangement	Recorded at Waste Management		Manifest/Disposal Certificate Information			Manifest Form (Y/N)	Weight Ticket (Y/N)	Disposal Certificate (Y/N)	
	Weight (lbs)	Weight (tons)	Rcvd Date	Receipt #	Manifest #				
10/10/2013	1	64,940	32.47	1	10/10/2013	429202 011886723JJK	Y	Y	Y
	2	53,160	26.58	2	10/10/2013	429203 011886724JJK	Y	Y	Y
	3	65,100	32.55	3	10/10/2013	429204 011886722JJK	Y	Y	Y
	4	63,380	31.69	4	10/10/2013	429205 011886721JJK	Y	Y	Y
	5	61,040	30.52	5	10/10/2013	429210 011886719JJK	Y	Y	Y
	6	60,800	30.40	6	10/10/2013	429211 011886720JJK	Y	Y	Y
	7	62,760	31.38	7	10/10/2013	429213 011886718JJK	Y	Y	Y
	8	66,700	33.35	8	10/10/2013	429215 011886716JJK	Y	Y	Y
	9	61,080	30.54	9	10/10/2013	429216 011886717JJK	Y	Y	Y
	10	65,360	32.68	10	10/10/2013	429221 011886769JJK	Y	Y	Y
	11	66,660	33.33	11	10/10/2013	429223 011886779JJK	Y	Y	Y
	12	64,360	32.18	12	10/10/2013	429224 011886781JJK	Y	Y	Y
	13	63,860	31.93	13	10/10/2013	429226 011886780JJK	Y	Y	Y
	14	67,740	33.87	14	10/10/2013	429229 011886763JJK	Y	Y	Y
	15	57,800	28.90	15	10/10/2013	429230 011886762JJK	Y	Y	Y
	Total	944,740	472.37						

**APPENDIX G - TRUCK TONNAGE REPORT
 INTERIM ACTION COMPLETION REPORT
 SPENT POT LINING AREA
 TACOMA, WASHINGTON**

Date Received at Waste Mangement	Recorded at Waste Management			Manifest/Disposal Certificate Information			Manifest Form (Y/N)	Weight Ticket (Y/N)	Disposal Certificate (Y/N)
	Weight (lbs)	Weight (tons)		Rcvd Date	Receipt #	Manifest #			
10/11/2013	1	63,360	31.68	1	10/11/2013	429254 011886705JJK	Y	Y	Y
	2	64,680	32.34	2	10/11/2013	429257 011886710JJK	Y	Y	Y
	3	65,900	32.95	3	10/11/2013	429259 011886765JJK	Y	Y	Y
	4	62,900	31.45	4	10/11/2013	429260 011886704JJK	Y	Y	Y
	5	64,480	32.24	5	10/11/2013	429261 011886767JJK	Y	Y	Y
	6	67,360	33.68	6	10/11/2013	429262 011886766JJK	Y	Y	Y
	7	68,040	34.02	7	10/11/2013	429273 011886714JJK	Y	Y	Y
	8	65,980	32.99	8	10/11/2013	429274 011886768JJK	Y	Y	Y
	9	64,900	32.45	9	10/11/2013	429276 011886715JJK	Y	Y	Y
	10	64,040	32.02	10	10/11/2013	429277 011886707JJK	Y	Y	Y
	11	68,300	34.15	11	10/11/2013	429278 011886764JJK	Y	Y	Y
	12	64,660	32.33	12	10/11/2013	429279 011886708JJK	Y	Y	Y
	13	64,820	32.41	13	10/11/2013	429280 011886709JJK	Y	Y	Y
	14	66,060	33.03	14	10/11/2013	429285 011886706JJK	Y	Y	Y
	15	65,440	32.72	15	10/11/2013	429286 011886713JJK	Y	Y	Y
	16	65,140	32.57	16	10/11/2013	429292 011886711JJK	Y	Y	Y
	17	60,500	30.25	17	10/11/2013	429294 011886703JJK	Y	Y	Y
	18	67,000	33.50	18	10/11/2013	429295 011886712JJK	Y	Y	Y
	19	66,280	33.14	19	10/11/2013	429298 011886702JJK	Y	Y	Y
	Total	1,239,840	619.92						

**APPENDIX G - TRUCK TONNAGE REPORT
 INTERIM ACTION COMPLETION REPORT
 SPENT POT LINING AREA
 TACOMA, WASHINGTON**

Date Received at Waste Mangement	Recorded at Waste Management		Manifest/Disposal Certificate Information			Manifest Form (Y/N)	Weight Ticket (Y/N)	Disposal Certificate (Y/N)
	Weight (lbs)	Weight (tons)	Rcvd Date	Receipt #	Manifest #			
10/14/2013	1	63,260	31.63	1 10/14/2013	429320 011886681JJK	Y	Y	Y
	2	64,860	32.43	2 10/14/2013	429321 011886680JJK	Y	Y	Y
	3	64,880	32.44	3 10/14/2013	429322 011886682JJK	Y	Y	Y
	4	62,980	31.49	4 10/14/2013	429325 011886701JJK	Y	Y	Y
	5	66,500	33.25	5 10/14/2013	429326 011886683JJK	Y	Y	Y
	6	65,640	32.82	6 10/14/2013	429327 011886684JJK	Y	Y	Y
	7	65,680	32.84	7 10/14/2013	429328 011886679JJK	Y	Y	Y
	8	64,580	32.29	8 10/14/2013	429329 011886678JJK	Y	Y	Y
	9	65,400	32.70	9 10/14/2013	429331 011886687JJK	Y	Y	Y
	10	70,460	35.23	10 10/14/2013	429335 011886688JJK	Y	Y	Y
	11	62,960	31.48	11 10/14/2013	429336 011886686JJK	Y	Y	Y
	12	67,300	33.65	12 10/14/2013	429337 011886685JJK	Y	Y	Y
	13	57,060	28.53	13 10/14/2013	429338 011886691JJK	Y	Y	Y
	14	67,400	33.70	14 10/14/2013	429341 011886689JJK	Y	Y	Y
	15	63,300	31.65	15 10/14/2013	429350 011886690JJK	Y	Y	Y
	16	56,360	28.18	16 10/14/2013	429355 011886692JJK	Y	Y	Y
	Total	1,028,620	514.31					

**APPENDIX G - TRUCK TONNAGE REPORT
 INTERIM ACTION COMPLETION REPORT
 SPENT POT LINING AREA
 TACOMA, WASHINGTON**

Date Received at Waste Mangement	Recorded at Waste Management		Manifest/Disposal Certificate Information			Manifest Form (Y/N)	Weight Ticket (Y/N)	Disposal Certificate (Y/N)
	Weight (lbs)	Weight (tons)	Rcvd Date	Receipt #	Manifest #			
10/15/2013	1	61,640	30.82	1 10/15/2013	429379 011886700JJK	Y	Y	Y
	2	64,320	32.16	2 10/15/2013	429380 011886698JJK	Y	Y	Y
	3	64,360	32.18	3 10/15/2013	429381 011886699JJK	Y	Y	Y
	4	61,400	30.70	4 10/15/2013	429383 011886697JJK	Y	Y	Y
	5	62,520	31.26	5 10/15/2013	429386 011886696JJK	Y	Y	Y
	6	63,300	31.65	6 10/15/2013	429387 011886693JJK	Y	Y	Y
	7	67,460	33.73	7 10/15/2013	429389 011886695JJK	Y	Y	Y
	8	65,280	32.64	8 10/15/2013	429392 011886694JJK	Y	Y	Y
	9	66,640	33.32	9 10/15/2013	429395 011886677JJK	Y	Y	Y
	10	58,780	29.39	10 10/15/2013	429396 011886676JJK	Y	Y	Y
	11	65,800	32.90	11 10/15/2013	429399 011886673JJK	Y	Y	Y
	12	67,840	33.92	12 10/15/2013	429400 011886675JJK	Y	Y	Y
	13	70,860	35.43	13 10/15/2013	429401 011886674JJK	Y	Y	Y
	14	65,820	32.91	14 10/15/2013	429404 011886667JJK	Y	Y	Y
	15	66,620	33.31	15 10/15/2013	429408 011886669JJK	Y	Y	Y
	16	64,500	32.25	16 10/15/2013	429409 011886666JJK	Y	Y	Y
	17	57,440	28.72	17 10/15/2013	429416 011886670JJK	Y	Y	Y
	Total	1,094,580	547.29					

**APPENDIX G - TRUCK TONNAGE REPORT
 INTERIM ACTION COMPLETION REPORT
 SPENT POT LINING AREA
 TACOMA, WASHINGTON**

Date Received at Waste Mangement	Recorded at Waste Management			Manifest/Disposal Certificate Information			Manifest Form (Y/N)	Weight Ticket (Y/N)	Disposal Certificate (Y/N)
	Weight (lbs)	Weight (tons)		Rcvd Date	Receipt #	Manifest #			
10/16/2013	1	65,040	32.52	1	10/16/2013	429462 011886662JJK	Y	Y	Y
	2	63,280	31.64	2	10/16/2013	429463 011886661JJK	Y	Y	Y
	3	64,140	32.07	3	10/16/2013	429464 011886663JJK	Y	Y	Y
	4	64,580	32.29	4	10/16/2013	429470 011886665JJK	Y	Y	Y
	5	70,240	35.12	5	10/16/2013	429471 011886664JJK	Y	Y	Y
	6	72,440	36.22	6	10/16/2013	429475 011886668JJK	Y	Y	Y
	7	64,200	32.10	7	10/16/2013	429478 011886671JJK	Y	Y	Y
	8	65,460	32.73	8	10/16/2013	429480 011886655JJK	Y	Y	Y
	9	64,160	32.08	9	10/16/2013	429481 011886660JJK	Y	Y	Y
	10	66,380	33.19	10	10/16/2013	429485 011886672JJK	Y	Y	Y
	11	67,180	33.59	11	10/16/2013	429486 011886658JJK	Y	Y	Y
	12	68,020	34.01	12	10/16/2013	429487 011886659JJK	Y	Y	Y
	13	64,680	32.34	13	10/16/2013	429488 011886657JJK	Y	Y	Y
	14	62,080	31.04	14	10/16/2013	429489 011886656JJK	Y	Y	Y
	15	61,680	30.84	15	10/16/2013	429491 011886653JJK	Y	Y	Y
	16	67,780	33.89	16	10/16/2013	429492 011886654JJK	Y	Y	Y
	Total	1,051,340	525.67						

**APPENDIX G - TRUCK TONNAGE REPORT
INTERIM ACTION COMPLETION REPORT
SPENT POT LINING AREA
TACOMA, WASHINGTON**

Date Received at Waste Mangement	Recorded at Waste Management			Manifest/Disposal Certificate Information			Manifest Form (Y/N)	Weight Ticket (Y/N)	Disposal Certificate (Y/N)
	Weight (lbs)	Weight (tons)		Rcvd Date	Receipt #	Manifest #			
10/17/2013	1	66,760	33.38	1	10/17/2013	429521 011886640JJK	Y	Y	Y
	2	62,040	31.02	2	10/17/2013	429522 011886642JJK	Y	Y	Y
	3	64,960	32.48	3	10/17/2013	429523 011886639JJK	Y	Y	Y
	4	68,860	34.43	4	10/17/2013	429526 011886647JJK	Y	Y	Y
	5	65,680	32.84	5	10/17/2013	429527 011886641JJK	Y	Y	Y
	6	64,620	32.31	6	10/17/2013	429529 011886638JJK	Y	Y	Y
	7	62,460	31.23	7	10/17/2013	429532 011886648JJK	Y	Y	Y
	8	61,040	30.52	8	10/17/2013	429534 011886644JJK	Y	Y	Y
	9	60,000	30.00	9	10/17/2013	429536 011886646JJK	Y	Y	Y
	10	66,840	33.42	10	10/17/2013	429537 011886649JJK	Y	Y	Y
	11	65,720	32.86	11	10/17/2013	429538 011886643JJK	Y	Y	Y
	12	65,280	32.64	12	10/17/2013	429542 011886637JJK	Y	Y	Y
	13	65,680	32.84	13	10/17/2013	429543 011886636JJK	Y	Y	Y
	14	65,060	32.53	14	10/17/2013	429544 011886645JJK	Y	Y	Y
	15	66,860	33.43	15	10/17/2013	429546 011886635JJK	Y	Y	Y
	16	64,220	32.11	16	10/17/2013	429547 011886650JJK	Y	Y	Y
	17	69,780	34.89	17	10/17/2013	429549 011886634JJK	Y	Y	Y
	18	65,280	32.64	18	10/17/2013	429551 011886651JJK	Y	Y	Y
Total	1,171,140	585.57							
10/18/2013	1	71,840	35.92	1	10/18/2013	429580 011886633JJK	Y	Y	Y
	2	64,520	32.26	2	10/18/2013	429581 011886632JJK	Y	Y	Y
	3	68,660	34.33	3	10/18/2013	429582 011886631JJK	Y	Y	Y
	4	62,280	31.14	4	10/18/2013	429586 011886629JJK	Y	Y	Y
	5	72,480	36.24	5	10/18/2013	429587 011886630JJK	Y	Y	Y
Total	339,780	169.89							

**APPENDIX G - TRUCK TONNAGE REPORT
INTERIM ACTION COMPLETION REPORT
SPENT POT LINING AREA
TACOMA, WASHINGTON**

Date Received at Waste Mangement	Recorded at Waste Management		Manifest/Disposal Certificate Information			Manifest Form (Y/N)	Weight Ticket (Y/N)	Disposal Certificate (Y/N)
	Weight (lbs)	Weight (tons)	Rcvd Date	Receipt #	Manifest #			
10/21/2013	1	60,660	30.33	1 10/21/2013	429642 011886624JJK	Y	Y	Y
	2	63,160	31.58	2 10/21/2013	429643 011886625JJK	Y	Y	Y
	3	64,620	32.31	3 10/21/2013	429644 011886626JJK	Y	Y	Y
	4	67,060	33.53	4 10/21/2013	429647 011886627JJK	Y	Y	Y
	5	61,420	30.71	5 10/21/2013	429650 011886621JJK	Y	Y	Y
	6	68,560	34.28	6 10/21/2013	429654 011886613JJK	Y	Y	Y
	7	68,220	34.11	7 10/21/2013	429655 011886622JJK	Y	Y	Y
	8	58,400	29.20	8 10/21/2013	429657 011886652JJK	Y	Y	Y
	9	66,660	33.33	9 10/21/2013	429658 011886628JJK	Y	Y	Y
	10	68,580	34.29	10 10/21/2013	429661 011886615JJK	Y	Y	Y
	11	62,040	31.02	11 10/21/2013	429662 011886614JJK	Y	Y	Y
	12	67,020	33.51	12 10/21/2013	429664 011886616JJK	Y	Y	Y
	13	62,580	31.29	13 10/21/2013	429666 011886623JJK	Y	Y	Y
	14	68,080	34.04	14 10/21/2013	429669 011886618JJK	Y	Y	Y
	15	60,260	30.13	15 10/21/2013	429671 011886617JJK	Y	Y	Y
Total	967,320	483.66						
10/22/2013	1	63,620	31.81	1 10/22/2013	429700 011886992JJK	Y	Y	Y
	2	65,980	32.99	2 10/22/2013	429701 011886993JJK	Y	Y	Y
	3	64,120	32.06	3 10/22/2013	429702 011886994JJK	Y	Y	Y
	4	56,960	28.48	4 10/22/2013	429703 011886999JJK	Y	Y	Y
	5	63,560	31.78	5 10/22/2013	429705 011886998JJK	Y	Y	Y
	6	65,200	32.60	6 10/22/2013	429706 011886609JJK	Y	Y	Y
	7	66,880	33.44	7 10/22/2013	429708 011886995JJK	Y	Y	Y
	8	66,120	33.06	8 10/22/2013	429710 011886608JJK	Y	Y	Y
	9	68,160	34.08	9 10/22/2013	429711 011886997JJK	Y	Y	Y
	10	61,940	30.97	10 10/22/2013	429713 011886610JJK	Y	Y	Y
	11	58,540	29.27	11 10/22/2013	429717 011886612JJK	Y	Y	Y
	12	62,320	31.16	12 10/22/2013	429720 011886996JJK	Y	Y	Y
	13	71,300	35.65	13 10/22/2013	429722 011886607JJK	Y	Y	Y
	14	64,160	32.08	14 10/22/2013	429726 011886611JJK	Y	Y	Y
	15	68,700	34.35	15 10/22/2013	429727 011886620JJK	Y	Y	Y

**APPENDIX G - TRUCK TONNAGE REPORT
INTERIM ACTION COMPLETION REPORT
SPENT POT LINING AREA
TACOMA, WASHINGTON**

Date Received at Waste Mangement	Recorded at Waste Management		Manifest/Disposal Certificate Information			Manifest Form (Y/N)	Weight Ticket (Y/N)	Disposal Certificate (Y/N)
	Weight (lbs)	Weight (tons)	Rcvd Date	Receipt #	Manifest #			
Total	967,560	483.78						
10/23/2013	1	62,980	31.49	1 10/23/2013	429737 011886619JJK	Y	Y	Y
	2	64,260	32.13	2 10/23/2013	429758 011886605JJK	Y	Y	Y
	3	66,620	33.31	3 10/23/2013	429759 011886604JJK	Y	Y	Y
	4	64,520	32.26	4 10/23/2013	429762 011886601JJK	Y	Y	Y
	5	63,600	31.80	5 10/23/2013	429765 011886600JJK	Y	Y	Y
	6	65,840	32.92	6 10/23/2013	429769 011886991JJK	Y	Y	Y
	7	66,140	33.07	7 10/23/2013	429772 011886989JJK	Y	Y	Y
	8	53,680	26.84	8 10/23/2013	429775 011886599JJK	Y	Y	Y
	9	63,600	31.80	9 10/23/2013	429776 011886990JJK	Y	Y	Y
	10	61,700	30.85	10 10/23/2013	429782 011886603JJK	Y	Y	Y
	11	70,320	35.16	11 10/23/2013	429788 011886602JJK	Y	Y	Y
Total	703,260	351.63						
10/24/2013	1	78,820	39.41	1 10/24/2013	429801 011886606JJK	Y	Y	Y
	2	65,840	32.92	2 10/24/2013	429835 011886984JJK	Y	Y	Y
	3	62,020	31.01	3 10/24/2013	429836 011886985JJK	Y	Y	Y
	4	68,000	34.00	4 10/24/2013	429840 011886988JJK	Y	Y	Y
	5	64,320	32.16	5 10/24/2013	429845 011886983JJK	Y	Y	Y
	6	63,680	31.84	6 10/24/2013	429846 011886981JJK	Y	Y	Y
	7	57,880	28.94	7 10/24/2013	429847 011886987JJK	Y	Y	Y
	8	65,140	32.57	8 10/24/2013	429848 011886982JJK	Y	Y	Y
	9	65,340	32.67	9 10/24/2013	429857 011886986JJK	Y	Y	Y
	10	67,260	33.63	10 10/24/2013	429858 011886974JJK	Y	Y	Y
Total	658,300	329.15						

**APPENDIX G - TRUCK TONNAGE REPORT
INTERIM ACTION COMPLETION REPORT
SPENT POT LINING AREA
TACOMA, WASHINGTON**

Date Received at Waste Management	Recorded at Waste Management		Manifest/Disposal Certificate Information			Manifest Form (Y/N)	Weight Ticket (Y/N)	Disposal Certificate (Y/N)
	Weight (lbs)	Weight (tons)	Rcvd Date	Receipt #	Manifest #			
10/25/2013	1	65,780	32.89	1 10/25/2013	429875 011886975JJK	Y	Y	Y
	2	62,440	31.22	2 10/25/2013	429897 011886979JJK	Y	Y	Y
	3	63,900	31.95	3 10/25/2013	429898 011886980JJK	Y	Y	Y
	4	63,820	31.91	4 10/25/2013	429899 011886967JJK	Y	Y	Y
	5	67,840	33.92	5 10/25/2013	429901 011886966JJK	Y	Y	Y
	6	68,940	34.47	6 10/25/2013	429903 011886970JJK	Y	Y	Y
	7	64,900	32.45	7 10/25/2013	429904 011886977JJK	Y	Y	Y
	8	64,680	32.34	8 10/25/2013	429905 011886968JJK	Y	Y	Y
	9	64,200	32.10	9 10/25/2013	429906 011886978JJK	Y	Y	Y
	10	64,860	32.43	10 10/25/2013	429909 011886976JJK	Y	Y	Y
	11	59,820	29.91	11 10/25/2013	429911 011886969JJK	Y	Y	Y
	12	65,900	32.95	12 10/25/2013	429912 011886971JJK	Y	Y	Y
	13	64,020	32.01	13 10/25/2013	429927 011886973JJK	Y	Y	Y
Total	841,100	420.55						
10/28/2013	1	64,620	32.31	1 10/28/2013	429965 011886965JJK	Y	Y	Y
	2	59,880	29.94	2 10/28/2013	429968 011886962JJK	Y	Y	Y
	3	64,680	32.34	3 10/28/2013	429970 011886963JJK	Y	Y	Y
	4	62,980	31.49	4 10/28/2013	429972 011886961JJK	Y	Y	Y
	5	63,560	31.78	5 10/28/2013	429973 011886960JJK	Y	Y	Y
	6	64,620	32.31	6 10/28/2013	429975 011886972JJK	Y	Y	Y
	7	62,820	31.41	7 10/28/2013	429978 011886964JJK	Y	Y	Y
Total	443,160	221.58						

**APPENDIX G - TRUCK TONNAGE REPORT
 INTERIM ACTION COMPLETION REPORT
 SPENT POT LINING AREA
 TACOMA, WASHINGTON**

Date Received at Waste Mangement	Recorded at Waste Management			Manifest/Disposal Certificate Information			Manifest Form (Y/N)	Weight Ticket (Y/N)	Disposal Certificate (Y/N)
	Weight (lbs)	Weight (tons)		Rcvd Date	Receipt #	Manifest #			
10/29/2013	1	62,080	31.04	1 10/29/2013	429999	011886959JJK	Y	Y	Y
	2	63,940	31.97	2 10/29/2013	430022	011886957JJK	Y	Y	Y
	3	65,980	32.99	3 10/29/2013	430026	011886952JJK	Y	Y	Y
	4	65,500	32.75	4 10/29/2013	430027	011886954JJK	Y	Y	Y
	5	66,840	33.42	5 10/29/2013	430028	011886950JJK	Y	Y	Y
	6	66,360	33.18	6 10/29/2013	430029	011886943JJK	Y	Y	Y
	7	64,700	32.35	7 10/29/2013	430030	011886955JJK	Y	Y	Y
	8	63,860	31.93	8 10/29/2013	430031	011886949JJK	Y	Y	Y
	9	61,580	30.79	9 10/29/2013	430033	011886948JJK	Y	Y	Y
	10	56,760	28.38	10 10/29/2013	430037	011886944JJK	Y	Y	Y
	11	62,760	31.38	11 10/29/2013	430038	011886951JJK	Y	Y	Y
	12	65,160	32.58	12 10/29/2013	430041	011886953JJK	Y	Y	Y
	13	62,640	31.32	13 10/29/2013	430042	011886942JJK	Y	Y	Y
	14	65,500	32.75	14 10/29/2013	430045	011886947JJK	Y	Y	Y
	Total	893,660	446.83						

**APPENDIX G - TRUCK TONNAGE REPORT
 INTERIM ACTION COMPLETION REPORT
 SPENT POT LINING AREA
 TACOMA, WASHINGTON**

Date Received at Waste Mangement	Recorded at Waste Management		Manifest/Disposal Certificate Information			Manifest Form (Y/N)	Weight Ticket (Y/N)	Disposal Certificate (Y/N)	
	Weight (lbs)	Weight (tons)	Rcvd Date	Receipt #	Manifest #				
10/30/2013	1	60,500	30.25	1	10/30/2013	430059 011886945JJK	Y	Y	Y
	2	65,740	32.87	2	10/30/2013	430084 011886933JJK	Y	Y	Y
	3	63,840	31.92	3	10/30/2013	430088 011886934JJK	Y	Y	Y
	4	64,640	32.32	4	10/30/2013	430089 011886935JJK	Y	Y	Y
	5	67,700	33.85	5	10/30/2013	430090 011886937JJK	Y	Y	Y
	6	61,840	30.92	6	10/30/2013	430091 011886936JJK	Y	Y	Y
	7	64,420	32.21	7	10/30/2013	430092 011886938JJK	Y	Y	Y
	8	65,500	32.75	8	10/30/2013	430093 011886941JJK	Y	Y	Y
	9	67,840	33.92	9	10/30/2013	430094 011886932JJK	Y	Y	Y
	10	65,840	32.92	10	10/30/2013	430095 011886940JJK	Y	Y	Y
	11	67,240	33.62	11	10/30/2013	430096 011886939JJK	Y	Y	Y
	12	64,260	32.13	12	10/30/2013	430098 011886929JJK	Y	Y	Y
	13	61,980	30.99	13	10/30/2013	430100 011886927JJK	Y	Y	Y
	14	67,580	33.79	14	10/30/2013	430101 011886930JJK	Y	Y	Y
	15	63,080	31.54	15	10/30/2013	430102 011886926JJK	Y	Y	Y
	16	63,640	31.82	16	10/30/2013	430105 011886925JJK	Y	Y	Y
	17	59,540	29.77	17	10/30/2013	430109 011886931JJK	Y	Y	Y
	18	69,400	34.70	18	10/30/2013	430099 011886928JJK	Y	Y	Y
	Total	1,164,580	582.29						

**APPENDIX G - TRUCK TONNAGE REPORT
 INTERIM ACTION COMPLETION REPORT
 SPENT POT LINING AREA
 TACOMA, WASHINGTON**

Date Received at Waste Mangement	Recorded at Waste Management		Manifest/Disposal Certificate Information			Manifest Form (Y/N)	Weight Ticket (Y/N)	Disposal Certificate (Y/N)	
	Weight (lbs)	Weight (tons)	Rcvd Date	Receipt #	Manifest #				
10/31/2013	1	63,380	31.69	1	10/31/2013	430126 011886924JJK	Y	Y	Y
	2	64,040	32.02	2	10/31/2013	430147 011886923JJK	Y	Y	Y
	3	63,340	31.67	3	10/31/2013	430148 011886922JJK	Y	Y	Y
	4	64,500	32.25	4	10/31/2013	430150 011886921JJK	Y	Y	Y
	5	66,900	33.45	5	10/31/2013	430153 011886920JJK	Y	Y	Y
	6	68,520	34.26	6	10/31/2013	430154 011886919JJK	Y	Y	Y
	7	64,900	32.45	7	10/31/2013	430155 011886915JJK	Y	Y	Y
	8	68,760	34.38	8	10/31/2013	430156 011886916JJK	Y	Y	Y
	9	64,080	32.04	9	10/31/2013	430157 011886917JJK	Y	Y	Y
	10	63,380	31.69	10	10/31/2013	430160 011886913JJK	Y	Y	Y
	11	62,360	31.18	11	10/31/2013	430161 011886914JJK	Y	Y	Y
	12	64,440	32.22	12	10/31/2013	430162 011886918JJK	Y	Y	Y
	13	63,960	31.98	13	10/31/2013	430164 011886908JJK	Y	Y	Y
	14	64,180	32.09	14	10/31/2013	430166 011886912JJK	Y	Y	Y
	15	60,320	30.16	15	10/31/2013	430171 011886907JJK	Y	Y	Y
	Total	967,060	483.53						

**APPENDIX G - TRUCK TONNAGE REPORT
INTERIM ACTION COMPLETION REPORT
SPENT POT LINING AREA
TACOMA, WASHINGTON**

Date Received at Waste Mangement	Recorded at Waste Management			Manifest/Disposal Certificate Information			Manifest Form (Y/N)	Weight Ticket (Y/N)	Disposal Certificate (Y/N)
	Weight (lbs)	Weight (tons)		Rcvd Date	Receipt #	Manifest #			
11/1/2013	1	61240.00	30.62	1	11/1/2013	430183 011886909JJK	Y	Y	Y
	2	65600.00	32.80	2	11/1/2013	430208 011886906JJK	Y	Y	Y
	3	62520.00	31.26	3	11/1/2013	430210 011886911JJK	Y	Y	Y
	4	61540.00	30.77	4	11/1/2013	430211 011886904JJK	Y	Y	Y
	5	63780.00	31.89	5	11/1/2013	430212 011886905JJK	Y	Y	Y
	6	65900.00	32.95	6	11/1/2013	430218 011886903JJK	Y	Y	Y
	7	65700.00	32.85	7	11/1/2013	430223 011886901JJK	Y	Y	Y
	8	68600.00	34.30	8	11/1/2013	430224 011886900JJK	Y	Y	Y
	9	65360.00	32.68	9	11/1/2013	430225 011886898JJK	Y	Y	Y
	10	69860.00	34.93	10	11/1/2013	430226 011886897JJK	Y	Y	Y
	11	61300.00	30.65	11	11/1/2013	430227 011886896JJK	Y	Y	Y
	12	61640.00	30.82	12	11/1/2013	430230 011886894JJK	Y	Y	Y
	13	64160.00	32.08	13	11/1/2013	430231 011886895JJK	Y	Y	Y
	14	59420.00	29.71	14	11/1/2013	430232 011886893JJK	Y	Y	Y
	15	64240.00	32.12	15	11/1/2013	430233 011886910JJK	Y	Y	Y
	16	68280.00	34.14	16	11/1/2013	430235 011886902JJK	Y	Y	Y
Total	1,029,140	514.57							
11/4/2013	1	67180.00	33.59	1	11/4/2013	430262 011886886JJK	Y	Y	Y
	2	61980.00	30.99	2	11/4/2013	430263 011886892JJK	Y	Y	Y
	3	63080.00	31.54	3	11/4/2013	430264 011886891JJK	Y	Y	Y
	4	61200.00	30.60	4	11/4/2013	430266 011886887JJK	Y	Y	Y
	5	63500.00	31.75	5	11/4/2013	430267 011886890JJK	Y	Y	Y
	6	64600.00	32.30	6	11/4/2013	430268 011886881JJK	Y	Y	Y
	7	60480.00	30.24	7	11/4/2013	430270 011886885JJK	Y	Y	Y
	8	64000.00	32.00	8	11/4/2013	430271 011886888JJK	Y	Y	Y
	9	62980.00	31.49	9	11/4/2013	430273 011886884JJK	Y	Y	Y
	10	62860.00	31.43	10	11/4/2013	430276 011886889JJK	Y	Y	Y
	11	65940.00	32.97	11	11/4/2013	430279 011886879JJK	Y	Y	Y
	12	67900.00	33.95	12	11/4/2013	430280 011886882JJK	Y	Y	Y
	13	71540.00	35.77	13	11/4/2013	430282 011886880JJK	Y	Y	Y
	14	64760.00	32.38	14	11/4/2013	430287 011886877JJK	Y	Y	Y

**APPENDIX G - TRUCK TONNAGE REPORT
 INTERIM ACTION COMPLETION REPORT
 SPENT POT LINING AREA
 TACOMA, WASHINGTON**

Date Received at Waste Mangement	Recorded at Waste Management		Manifest/Disposal Certificate Information			Manifest Form (Y/N)	Weight Ticket (Y/N)	Disposal Certificate (Y/N)	
	Weight (lbs)	Weight (tons)	Rcvd Date	Receipt #	Manifest #				
Total	902,000	451.00							
11/5/2013	1	66280.00	33.14	1	11/5/2013	430298 011886876JJK	Y	Y	Y
	2	30560.00	15.28	2	11/5/2013	430300 011886878JJK	Y	Y	Y
	3	64720.00	32.36	3	11/5/2013	430308 011886958JJK	Y	Y	Y
	4	63620.00	31.81	4	11/5/2013	430330 011886867JJK	Y	Y	Y
	5	68080.00	34.04	5	11/5/2013	430331 011886866JJK	Y	Y	Y
	6	64300.00	32.15	6	11/5/2013	430332 011886865JJK	Y	Y	Y
	7	64120.00	32.06	7	11/5/2013	430333 011886875JJK	Y	Y	Y
	8	63540.00	31.77	8	11/5/2013	430334 011886872JJK	Y	Y	Y
	9	65060.00	32.53	9	11/5/2013	430336 011886870JJK	Y	Y	Y
	10	65800.00	32.90	10	11/5/2013	430337 011886873JJK	Y	Y	Y
	11	68180.00	34.09	11	11/5/2013	430338 011886874JJK	Y	Y	Y
	12	67540.00	33.77	12	11/5/2013	430340 011886857JJK	Y	Y	Y
	13	67700.00	33.85	13	11/5/2013	430341 011886869JJK	Y	Y	Y
	14	62720.00	31.36	14	11/5/2013	430343 011886871JJK	Y	Y	Y
	15	63060.00	31.53	15	11/5/2013	430345 011886862JJK	Y	Y	Y
	16	65500.00	32.75	16	11/5/2013	430347 011886854JJK	Y	Y	Y
	17	63340.00	31.67	17	11/5/2013	430348 011886864JJK	Y	Y	Y
	18	65500.00	32.75	18	11/5/2013	430349 011886858JJK	Y	Y	Y
	19	62120.00	31.06	19	11/5/2013	430350 011886856JJK	Y	Y	Y
	20	61960.00	30.98	20	11/5/2013	430351 011886861JJK	Y	Y	Y
	21	63480.00	31.74	21	11/5/2013	430353 011886851JJK	Y	Y	Y
	22	66400.00	33.20	22	11/5/2013	430354 011886863JJK	Y	Y	Y
	23	66480.00	33.24	23	11/5/2013	430356 011886859JJK	Y	Y	Y
	24	73780.00	36.89	24	11/5/2013	430358 011886853JJK	Y	Y	Y
	25	65800.00	32.90	25	11/5/2013	430359 011886860JJK	Y	Y	Y
	26	68460.00	34.23	26	11/5/2013	430360 011886855JJK	Y	Y	Y
	27	61920.00	30.96	27	11/5/2013	430361 011886852JJK	Y	Y	Y
	28	65760.00	32.88	28	11/5/2013	430365 011886845JJK	Y	Y	Y
	29	65180.00	32.59	29	11/5/2013	430368 011886846JJK	Y	Y	Y
	30	62300.00	31.15	30	11/5/2013	430369 011886848JJK	Y	Y	Y

**APPENDIX G - TRUCK TONNAGE REPORT
 INTERIM ACTION COMPLETION REPORT
 SPENT POT LINING AREA
 TACOMA, WASHINGTON**

Date Received at Waste Mangement	Recorded at Waste Management		Manifest/Disposal Certificate Information			Manifest Form (Y/N)	Weight Ticket (Y/N)	Disposal Certificate (Y/N)		
	Weight (lbs)	Weight (tons)	Rcvd Date	Receipt #	Manifest #					
Total	1,923,260.00	961.63								
11/6/2013	1	64140.00	32.07	1	11/6/2013	430401	011886843JJK	Y	Y	Y
	2	62880.00	31.44	2	11/6/2013	430402	011886844JJK	Y	Y	Y
	3	61840.00	30.92	3	11/6/2013	430403	011886842JJK	Y	Y	Y
	4	64260.00	32.13	4	11/6/2013	430404	011886841JJK	Y	Y	Y
	5	64740.00	32.37	5	11/6/2013	430405	011886839JJK	Y	Y	Y
	6	65740.00	32.87	6	11/6/2013	430406	011886838JJK	Y	Y	Y
	7	63560.00	31.78	7	11/6/2013	430407	011886840JJK	Y	Y	Y
	8	57520.00	28.76	8	11/6/2013	430408	011886850JJK	Y	Y	Y
	9	66420.00	33.21	9	11/6/2013	430411	011886831JJK	Y	Y	Y
	10	67760.00	33.88	10	11/6/2013	430412	011886836JJK	Y	Y	Y
	11	65980.00	32.99	11	11/6/2013	430415	011886837JJK	Y	Y	Y
	12	64380.00	32.19	12	11/6/2013	430418	011886834JJK	Y	Y	Y
	13	62260.00	31.13	13	11/6/2013	430419	011886835JJK	Y	Y	Y
	14	66620.00	33.31	14	11/6/2013	430420	011886832JJK	Y	Y	Y
	15	65500.00	32.75	15	11/6/2013	430421	011886849JJK	Y	Y	Y
	16	66360.00	33.18	16	11/6/2013	430422	011886833JJK	Y	Y	Y
	17	71540.00	35.77	17	11/6/2013	430424	011886830JJK	Y	Y	Y
	18	66900.00	33.45	18	11/6/2013	430425	011886829JJK	Y	Y	Y
	19	61360.00	30.68	19	11/6/2013	430426	011886824JJK	Y	Y	Y
	20	69140.00	34.57	20	11/6/2013	430427	011886823JJK	Y	Y	Y
	21	64840.00	32.42	21	11/6/2013	430428	011886828JJK	Y	Y	Y
	22	68320.00	34.16	22	11/6/2013	430434	011886820JJK	Y	Y	Y
	23	67860.00	33.93	23	11/6/2013	430435	011886821JJK	Y	Y	Y
	24	59420.00	29.71	24	11/6/2013	430436	011886826JJK	Y	Y	Y
	25	67020.00	33.51	25	11/6/2013	430437	011886827JJK	Y	Y	Y
Total	1626360.00	813.18								

**APPENDIX G - TRUCK TONNAGE REPORT
INTERIM ACTION COMPLETION REPORT
SPENT POT LINING AREA
TACOMA, WASHINGTON**

Date Received at Waste Mangement	Recorded at Waste Management		Manifest/Disposal Certificate Information			Manifest Form (Y/N)	Weight Ticket (Y/N)	Disposal Certificate (Y/N)		
	Weight (lbs)	Weight (tons)	Rcvd Date	Receipt #	Manifest #					
11/7/2013	1	62620.00	31.31	1	11/7/2013	430448	011886825JJK	Y	Y	Y
	2	64840.00	32.42	2	11/7/2013	430487	011886818JJK	Y	Y	Y
	3	63140.00	31.57	3	11/7/2013	430499	011886819JJK	Y	Y	Y
	4	60200.00	30.10	4	11/7/2013	430500	011886812JJK	Y	Y	Y
	5	62980.00	31.49	5	11/7/2013	430501	011886814JJK	Y	Y	Y
	6	65460.00	32.73	6	11/7/2013	430502	011886815JJK	Y	Y	Y
	7	65340.00	32.67	7	11/7/2013	430503	011886813JJK	Y	Y	Y
	8	62940.00	31.47	8	11/7/2013	430504	011886816JJK	Y	Y	Y
	9	63320.00	31.66	9	11/7/2013	430506	011886807JJK	Y	Y	Y
	10	64980.00	32.49	10	11/7/2013	430509	011886822JJK	Y	Y	Y
	11	68740.00	34.37	11	11/7/2013	430510	011886811JJK	Y	Y	Y
	12	67040.00	33.52	12	11/7/2013	430513	011886817JJK	Y	Y	Y
	13	65140.00	32.57	13	11/7/2013	430516	011886809JJK	Y	Y	Y
	14	60920.00	30.46	14	11/7/2013	430517	011886808JJK	Y	Y	Y
	15	66060.00	33.03	15	11/7/2013	430518	011886806JJK	Y	Y	Y
	16	64280.00	32.14	16	11/7/2013	430520	011886799JJK	Y	Y	Y
	17	63460.00	31.73	17	11/7/2013	430521	011886800JJK	Y	Y	Y
	18	65000.00	32.50	18	11/7/2013	430522	011886801JJK	Y	Y	Y
	19	65420.00	32.71	19	11/7/2013	430524	011886805JJK	Y	Y	Y
	20	66420.00	33.21	20	11/7/2013	430527	011886810JJK	Y	Y	Y
	21	63680.00	31.84	21	11/7/2013	430529	011886803JJK	Y	Y	Y
	22	67300.00	33.65	22	11/7/2013	430530	011886804JJK	Y	Y	Y
Total		1,419,280	709.64							

**APPENDIX G - TRUCK TONNAGE REPORT
INTERIM ACTION COMPLETION REPORT
SPENT POT LINING AREA
TACOMA, WASHINGTON**

Date Received at Waste Mangement	Recorded at Waste Management		Manifest/Disposal Certificate Information			Manifest Form (Y/N)	Weight Ticket (Y/N)	Disposal Certificate (Y/N)		
	Weight (lbs)	Weight (tons)	Rcvd Date	Receipt #	Manifest #					
11/11/2013	1	63860.00	31.93	1	11/11/2013	430604	011871793JJK	Y	Y	Y
	2	60680.00	30.34	2	11/11/2013	430606	011871794JJK	Y	Y	Y
	3	60440.00	30.22	3	11/11/2013	430607	011871795JJK	Y	Y	Y
	4	61100.00	30.55	4	11/11/2013	430608	011871796JJK	Y	Y	Y
	5	63840.00	31.92	5	11/11/2013	430614	011871797JJK	Y	Y	Y
	6	67280.00	33.64	6	11/11/2013	430615	011871799JJK	Y	Y	Y
	7	61800.00	30.90	7	11/11/2013	430616	011886802JJK	Y	Y	Y
	8	61620.00	30.81	8	11/11/2013	430617	011871798JJK	Y	Y	Y
	9	66260.00	33.13	9	11/11/2013	430620	011871800JJK	Y	Y	Y
	10	67460.00	33.73	10	11/11/2013	430621	011871806JJK	Y	Y	Y
	11	66900.00	33.45	11	11/11/2013	430622	011871807JJK	Y	Y	Y
	12	66200.00	33.10	12	11/11/2013	430623	011871805JJK	Y	Y	Y
	13	69800.00	34.90	13	11/11/2013	430624	011871802JJK	Y	Y	Y
	14	63980.00	31.99	14	11/11/2013	430625	011871804JJK	Y	Y	Y
	15	67480.00	33.74	15	11/11/2013	430626	011871801JJK	Y	Y	Y
	16	67300.00	33.65	16	11/11/2013	430627	011871792JJK	Y	Y	Y
	17	60580.00	30.29	17	11/11/2013	430630	011871808JJK	Y	Y	Y
	18	61500.00	30.75	18	11/11/2013	430631	011871803JJK	Y	Y	Y
Total	1,158,080	579.04								
11/13/2013	1	63040.00	31.52	1	11/13/2013	430717	011871811JJK	Y	Y	Y
	2	62840.00	31.42	2	11/13/2013	430722	011871809JJK	Y	Y	Y
	3	61880.00	30.94	3	11/13/2013	430724	011871810JJK	Y	Y	Y
Total	187,760	93.88								

**APPENDIX G - TRUCK TONNAGE REPORT
 INTERIM ACTION COMPLETION REPORT
 SPENT POT LINING AREA
 TACOMA, WASHINGTON**

Date Received at Waste Mangement	Recorded at Waste Management		Manifest/Disposal Certificate Information			Manifest Form (Y/N)	Weight Ticket (Y/N)	Disposal Certificate (Y/N)		
	Weight (lbs)	Weight (tons)	Rcvd Date	Receipt #	Manifest #					
11/14/2013	1	62320.00	31.16	1	11/14/2013	430762	011871814JJK	Y	Y	Y
	2	61000.00	30.50	2	11/14/2013	430765	011871815JJK	Y	Y	Y
	3	62980.00	31.49	3	11/14/2013	430768	011871813JJK	Y	Y	Y
	4	62360.00	31.18	4	11/14/2013	430770	011871816JJK	Y	Y	Y
	5	68000.00	34.00	5	11/14/2013	430771	011871817JJK	Y	Y	Y
	6	68800.00	34.40	6	11/14/2013	430777	011871819JJK	Y	Y	Y
	7	59360.00	29.68	7	11/14/2013	430778	011871820JJK	Y	Y	Y
	8	71940.00	35.97	8	11/14/2013	430779	011871812JJK	Y	Y	Y
Total		516,760	258.38							

Total: 77,675,880 38,837.94



CHEMICAL WASTE MANAGEMENT OF THE NW

17629 Cedar Springs Lane
Arlington, OR 97812
(541) 454-2643
(541) 454-3279 Fax

PORT OF TACOMA
WAD001882984
3400 TAYLOR WAY
TACOMA WA 98421

CERTIFICATE OF DISPOSAL

Chemical Waste Management of the Northwest, Inc., ORD089452353, has received the following waste material:

GENERATOR:	PORT OF TACOMA
MANIFEST #:	010585316JJK
CWM TRACKING ID:	42698801
PROFILE #:	OR321468
LINE ITEM:	9b.1
QUANTITY:	1 DT
RECEIVED DATE:	08/06/13
DISPOSAL PROCESS(ES):	LANDFILL
FINAL DISPOSAL LOCATION:	LANDFILL 13
DISPOSAL DATE:	08/06/13

I certify, on behalf of the above listed treatment facility, that to the best of my knowledge, the above-described waste material was managed in compliance with all applicable laws, regulations, permits and licenses on the date listed above.



CWMNW RECORDS DEPARTMENT

Date: 08/12/13

213055



CHEMICAL WASTE MANAGEMENT OF THE NORTHWEST
17629 Cedar Springs Lane
Arlington, OR 97812

PORT OF TACOMA
WAD001882984
3400 TAYLOR WAY
TACOMA WA 98421

CERTIFICATE OF DISPOSAL

Chemical Waste Management of the Northwest, Inc., ORD089452353, has received the following waste material:

GENERATOR:	PORT OF TACOMA
MANIFEST #:	010585319JJK
CWM TRACKING ID:	42698301
PROFILE #:	OR321468
LINE ITEM:	9b.1
QUANTITY:	1 DT
RECEIVED DATE:	08/06/13
DISPOSAL PROCESS(ES):	LANDFILL
FINAL DISPOSAL LOCATION:	LANDFILL 14
DISPOSAL DATE:	08/06/13

I certify, on behalf of the above listed treatment facility, that to the best of my knowledge, the above-described waste material was managed in compliance with all applicable laws, regulations, permits and licenses on the date listed above.

Robbin Jo Galvin

CWMNW RECORDS DEPARTMENT
Date: 08/12/13



CHEMICAL WASTE MANAGEMENT OF THE NORTHWEST

17629 Cedar Springs Lane
Arlington, OR 97812

PORT OF TACOMA
WAD001882984
3400 TAYLOR WAY
TACOMA WA 98421

CERTIFICATE OF DISPOSAL

Chemical Waste Management of the Northwest, Inc., ORD089452353, has received the following waste material:

GENERATOR: PORT OF TACOMA
MANIFEST #: 010585318JJK
CWM TRACKING ID: 42698601
PROFILE #: OR321468
LINE ITEM: 9b.1
QUANTITY: 1 DT
RECEIVED DATE: 08/06/13

DISPOSAL PROCESS(ES): LANDFILL
FINAL DISPOSAL LOCATION: LANDFILL 13
DISPOSAL DATE: 08/06/13

I certify, on behalf of the above listed treatment facility, that to the best of my knowledge, the above-described waste material was managed in compliance with all applicable laws, regulations, permits and licenses on the date listed above.



CWMNW RECORDS DEPARTMENT

Date: 08/12/13



CHEMICAL WASTE MANAGEMENT OF THE NORTHWEST
17629 Cedar Springs Lane
Arlington, OR 97812

PORT OF TACOMA
WAD001882984
3400 TAYLOR WAY
TACOMA WA 98421

CERTIFICATE OF DISPOSAL

Chemical Waste Management of the Northwest, Inc., ORD089452353, has received the following waste material:

GENERATOR:	PORT OF TACOMA	
MANIFEST #:	010085317JJK	
CWM TRACKING ID:	42698901	
PROFILE #:	OR321468	
LINE ITEM:	9b.1	
QUANTITY:	1 DT	
RECEIVED DATE:	08/06/13	
DISPOSAL PROCESS(ES):	LANDFILL	
FINAL DISPOSAL LOCATION:	LANDFILL	13
DISPOSAL DATE:	08/06/13	

I certify, on behalf of the above listed treatment facility, that to the best of my knowledge, the above-described waste material was managed in compliance with all applicable laws, regulations, permits and licenses on the date listed above.



CWMNW RECORDS DEPARTMENT

Date: 08/12/13



CHEMICAL WASTE MANAGEMENT OF THE NORTHWEST
17629 Cedar Springs Lane
Arlington, OR 97812

PORT OF TACOMA
WAD001882984
3400 TAYLOR WAY
TACOMA WA 98421

CERTIFICATE OF DISPOSAL

Chemical Waste Management of the Northwest, Inc., ORD089452353, has received the following waste material:

GENERATOR:	PORT OF TACOMA
MANIFEST #:	010585328JJK
CWM TRACKING ID:	42699301
PROFILE #:	OR321468
LINE ITEM:	9b.1
QUANTITY:	1 DT
RECEIVED DATE:	08/07/13
DISPOSAL PROCESS(ES):	LANDFILL
FINAL DISPOSAL LOCATION:	LANDFILL 13
DISPOSAL DATE:	08/07/13

I certify, on behalf of the above listed treatment facility, that to the best of my knowledge, the above-described waste material was managed in compliance with all applicable laws, regulations, permits and licenses on the date listed above.

Bobbi Jo Galum

CWMNW RECORDS DEPARTMENT

Date: 08/12/13





CHEMICAL WASTE MANAGEMENT OF THE NORTHWEST

17629 Cedar Springs Lane
Arlington, OR 97812

PORT OF TACOMA
WAD001882984
3400 TAYLOR WAY
TACOMA WA 98421

CERTIFICATE OF DISPOSAL

Chemical Waste Management of the Northwest, Inc., ORD089452353, has received the following waste material:

GENERATOR: PORT OF TACOMA
MANIFEST #: 010585320JJK
CWM TRACKING ID: 42699401
PROFILE #: OR321468
LINE ITEM: 9b.1
QUANTITY: 1 DT
RECEIVED DATE: 08/07/13

DISPOSAL PROCESS(ES): LANDFILL
FINAL DISPOSAL LOCATION: LANDFILL 13
DISPOSAL DATE: 08/07/13

I certify, on behalf of the above listed treatment facility, that to the best of my knowledge, the above-described waste material was managed in compliance with all applicable laws, regulations, permits and licenses on the date listed above.



CWMNW RECORDS DEPARTMENT

Date: 08/12/13



CHEMICAL WASTE MANAGEMENT OF THE NORTHWEST
17629 Cedar Springs Lane
Arlington, OR 97812

PORT OF TACOMA
WAD001882984
3400 TAYLOR WAY
TACOMA WA 98421

CERTIFICATE OF DISPOSAL

Chemical Waste Management of the Northwest, Inc., ORD089452353, has received the following waste material:

GENERATOR:	PORT OF TACOMA
MANIFEST #:	010585326JJK
CWM TRACKING ID:	42701101
PROFILE #:	OR321468
LINE ITEM:	9b.1
QUANTITY:	1 DT
RECEIVED DATE:	08/07/13
DISPOSAL PROCESS(ES):	LANDFILL
FINAL DISPOSAL LOCATION:	LANDFILL 13
DISPOSAL DATE:	08/07/13

I certify, on behalf of the above listed treatment facility, that to the best of my knowledge, the above-described waste material was managed in compliance with all applicable laws, regulations, permits and licenses on the date listed above.

Bobbi Jo Galvin

CWMNW RECORDS DEPARTMENT

Date: 08/12/13



CHEMICAL WASTE MANAGEMENT OF THE NORTHWEST
17629 Cedar Springs Lane
Arlington, OR 97812

PORT OF TACOMA
WAD001882984
3400 TAYLOR WAY
TACOMA WA 98421

CERTIFICATE OF DISPOSAL

Chemical Waste Management of the Northwest, Inc., ORD089452353, has received the following waste material:

GENERATOR:	PORT OF TACOMA	
MANIFEST #:	010585327JJK	
CWM TRACKING ID:	42701201	
PROFILE #:	OR321468	
LINE ITEM:	9b.1	
QUANTITY:	1 DT	
RECEIVED DATE:	08/07/13	
DISPOSAL PROCESS(ES):	LANDFILL	
FINAL DISPOSAL LOCATION:	LANDFILL	13
DISPOSAL DATE:	08/07/13	

I certify, on behalf of the above listed treatment facility, that to the best of my knowledge, the above-described waste material was managed in compliance with all applicable laws, regulations, permits and licenses on the date listed above.

Bobbi Jo Galvin

CWMNW RECORDS DEPARTMENT

Date: 08/12/13



CHEMICAL WASTE MANAGEMENT OF THE NORTHWEST
17629 Cedar Springs Lane
Arlington, OR 97812

PORT OF TACOMA
WAD001882984
3400 TAYLOR WAY
TACOMA WA 98421

CERTIFICATE OF DISPOSAL

Chemical Waste Management of the Northwest, Inc., ORD089452353, has received the following waste material:

GENERATOR:	PORT OF TACOMA
MANIFEST #:	010585325JJK
CWM TRACKING ID:	42701301
PROFILE #:	OR321468
LINE ITEM:	9b.1
QUANTITY:	1 DT
RECEIVED DATE:	08/07/13
DISPOSAL PROCESS(ES):	LANDFILL
FINAL DISPOSAL LOCATION:	LANDFILL 13
DISPOSAL DATE:	08/07/13

I certify, on behalf of the above listed treatment facility, that to the best of my knowledge, the above-described waste material was managed in compliance with all applicable laws, regulations, permits and licenses on the date listed above.

Bobbi Jo Galvin

CWMNW RECORDS DEPARTMENT

Date: 08/12/13



CHEMICAL WASTE MANAGEMENT OF THE NORTHWEST
17629 Cedar Springs Lane
Arlington, OR 97812

PORT OF TACOMA
WAD001882984
3400 TAYLOR WAY
TACOMA WA 98421

CERTIFICATE OF DISPOSAL

Chemical Waste Management of the Northwest, Inc., ORD089452353, has received the following waste material:

GENERATOR:	PORT OF TACOMA
MANIFEST #:	010585321JJK
CWM TRACKING ID:	42701401
PROFILE #:	OR321468
LINE ITEM:	9b.1
QUANTITY:	1 DT
RECEIVED DATE:	08/07/13
DISPOSAL PROCESS(ES):	LANDFILL
FINAL DISPOSAL LOCATION:	LANDFILL 13
DISPOSAL DATE:	08/07/13

I certify, on behalf of the above listed treatment facility, that to the best of my knowledge, the above-described waste material was managed in compliance with all applicable laws, regulations, permits and licenses on the date listed above.

Bobbi Jo Galvin

CWMNW RECORDS DEPARTMENT

Date:

08/12/13



CHEMICAL WASTE MANAGEMENT OF THE NORTHWEST
17629 Cedar Springs Lane
Arlington, OR 97812

PORT OF TACOMA
WAD001882984
3400 TAYLOR WAY
TACOMA WA 98421

CERTIFICATE OF DISPOSAL

Chemical Waste Management of the Northwest, Inc., ORD089452353, has received the following waste material:

GENERATOR:	PORT OF TACOMA
MANIFEST #:	010585324JJK
CWM TRACKING ID:	42701501
PROFILE #:	OR321468
LINE ITEM:	9b.1
QUANTITY:	1 DT
RECEIVED DATE:	08/07/13
DISPOSAL PROCESS(ES):	LANDFILL
FINAL DISPOSAL LOCATION:	LANDFILL 13
DISPOSAL DATE:	08/07/13

I certify, on behalf of the above listed treatment facility, that to the best of my knowledge, the above-described waste material was managed in compliance with all applicable laws, regulations, permits and licenses on the date listed above.

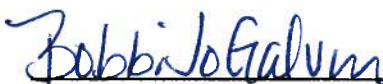

CWMNW RECORDS DEPARTMENT

Date: 08/12/13



CHEMICAL WASTE MANAGEMENT OF THE NORTHWEST
17629 Cedar Springs Lane
Arlington, OR 97812

PORT OF TACOMA
WAD001882984
3400 TAYLOR WAY
TACOMA WA 98421

CERTIFICATE OF DISPOSAL

Chemical Waste Management of the Northwest, Inc., ORD089452353, has received the following waste material:

GENERATOR:	PORT OF TACOMA
MANIFEST #:	010585323JJK
CWM TRACKING ID:	42701601
PROFILE #:	OR321468
LINE ITEM:	9b.1
QUANTITY:	1 DT
RECEIVED DATE:	08/07/13
DISPOSAL PROCESS(ES):	LANDFILL
FINAL DISPOSAL LOCATION:	LANDFILL 13
DISPOSAL DATE:	08/07/13

I certify, on behalf of the above listed treatment facility, that to the best of my knowledge, the above-described waste material was managed in compliance with all applicable laws, regulations, permits and licenses on the date listed above.



CWMNW RECORDS DEPARTMENT
Date: 08/12/13



CHEMICAL WASTE MANAGEMENT OF THE NORTHWEST
17629 Cedar Springs Lane
Arlington, OR 97812

PORT OF TACOMA
WAD001882984
3400 TAYLOR WAY
TACOMA WA 98421

CERTIFICATE OF DISPOSAL

Chemical Waste Management of the Northwest, Inc., ORD089452353, has received the following waste material:

GENERATOR:	PORT OF TACOMA
MANIFEST #:	010585322JJK
CWM TRACKING ID:	42701701
PROFILE #:	OR321468
LINE ITEM:	9b.1
QUANTITY:	1 DT
RECEIVED DATE:	08/07/13
DISPOSAL PROCESS(ES):	LANDFILL
FINAL DISPOSAL LOCATION:	LANDFILL 13
DISPOSAL DATE:	08/07/13

I certify, on behalf of the above listed treatment facility, that to the best of my knowledge, the above-described waste material was managed in compliance with all applicable laws, regulations, permits and licenses on the date listed above.

Robbin Alvin

CWMNW RECORDS DEPARTMENT

Date: 08/12/13



CHEMICAL WASTE MANAGEMENT OF THE NORTHWEST
17629 Cedar Springs Lane
Arlington, OR 97812

PORT OF TACOMA
WAD001882984
3400 TAYLOR WAY
TACOMA WA 98421

CERTIFICATE OF DISPOSAL

Chemical Waste Management of the Northwest, Inc., ORD089452353, has received the following waste material:

GENERATOR:	PORT OF TACOMA
MANIFEST #:	010585329JJK
CWM TRACKING ID:	42701901
PROFILE #:	OR321468
LINE ITEM:	9b.1
QUANTITY:	1 DT
RECEIVED DATE:	08/07/13
DISPOSAL PROCESS(ES):	LANDFILL
FINAL DISPOSAL LOCATION:	LANDFILL 13
DISPOSAL DATE:	08/07/13

I certify, on behalf of the above listed treatment facility, that to the best of my knowledge, the above-described waste material was managed in compliance with all applicable laws, regulations, permits and licenses on the date listed above.

Robbie Jo Galvin

CWMNW RECORDS DEPARTMENT

Date: 08/12/13



CHEMICAL WASTE MANAGEMENT OF THE NORTHWEST
17629 Cedar Springs Lane
Arlington, OR 97812

PORT OF TACOMA
WAD001882984
3400 TAYLOR WAY
TACOMA WA 98421

CERTIFICATE OF DISPOSAL

Chemical Waste Management of the Northwest, Inc., ORD089452353, has received the following waste material:

GENERATOR:	PORT OF TACOMA
MANIFEST #:	010585336JJK
CWM TRACKING ID:	42702001
PROFILE #:	OR321468
LINE ITEM:	9b.1
QUANTITY:	1 DT
RECEIVED DATE:	08/07/13
DISPOSAL PROCESS(ES):	LANDFILL
FINAL DISPOSAL LOCATION:	LANDFILL 13
DISPOSAL DATE:	08/07/13

I certify, on behalf of the above listed treatment facility, that to the best of my knowledge, the above-described waste material was managed in compliance with all applicable laws, regulations, permits and licenses on the date listed above.

Bobbi Jo Galvin

CWMNW RECORDS DEPARTMENT

Date: 08/12/13



CHEMICAL WASTE MANAGEMENT OF THE NORTHWEST
17629 Cedar Springs Lane
Arlington, OR 97812

PORT OF TACOMA
WAD001882984
3400 TAYLOR WAY
TACOMA WA 98421

CERTIFICATE OF DISPOSAL

Chemical Waste Management of the Northwest, Inc., ORD089452353, has received the following waste material:

GENERATOR:	PORT OF TACOMA
MANIFEST #:	010585330JJK
CWM TRACKING ID:	42702101
PROFILE #:	OR321468
LINE ITEM:	9b.1
QUANTITY:	1 DT
RECEIVED DATE:	08/07/13
DISPOSAL PROCESS(ES):	LANDFILL
FINAL DISPOSAL LOCATION:	LANDFILL 13
DISPOSAL DATE:	08/07/13

I certify, on behalf of the above listed treatment facility, that to the best of my knowledge, the above-described waste material was managed in compliance with all applicable laws, regulations, permits and licenses on the date listed above.

Bobbi Jo Galvin

CWMNW RECORDS DEPARTMENT

Date: 08/12/13



CHEMICAL WASTE MANAGEMENT OF THE NORTHWEST

17629 Cedar Springs Lane
Arlington, OR 97812

PORT OF TACOMA
WAD001882984
3400 TAYLOR WAY
TACOMA WA 98421

CERTIFICATE OF DISPOSAL

Chemical Waste Management of the Northwest, Inc., ORD089452353, has received the following waste material:

GENERATOR:	PORT OF TACOMA
MANIFEST #:	010585359JJK
CWM TRACKING ID:	42704201
PROFILE #:	OR321468
LINE ITEM:	9b.1
QUANTITY:	1 DT
RECEIVED DATE:	08/08/13
DISPOSAL PROCESS(ES):	LANDFILL
FINAL DISPOSAL LOCATION:	LANDFILL 13
DISPOSAL DATE:	08/08/13

I certify, on behalf of the above listed treatment facility, that to the best of my knowledge, the above-described waste material was managed in compliance with all applicable laws, regulations, permits and licenses on the date listed above.

Robbie Jo Galvin

CWMNW RECORDS DEPARTMENT

Date: 08/12/13



CHEMICAL WASTE MANAGEMENT OF THE NORTHWEST

17629 Cedar Springs Lane
Arlington, OR 97812

PORT OF TACOMA
WAD001882984
3400 TAYLOR WAY
TACOMA WA 98421

CERTIFICATE OF DISPOSAL

Chemical Waste Management of the Northwest, Inc., ORD089452353, has received the following waste material:

GENERATOR: PORT OF TACOMA
MANIFEST #: 010585363JJK
CWM TRACKING ID: 42704301
PROFILE #: OR321468
LINE ITEM: 9b.1
QUANTITY: 1 DT
RECEIVED DATE: 08/08/13

DISPOSAL PROCESS(ES): LANDFILL
FINAL DISPOSAL LOCATION: LANDFILL 13
DISPOSAL DATE: 08/08/13

I certify, on behalf of the above listed treatment facility, that to the best of my knowledge, the above-described waste material was managed in compliance with all applicable laws, regulations, permits and licenses on the date listed above.

CWMNW RECORDS DEPARTMENT

Date: 08/12/13



CHEMICAL WASTE MANAGEMENT OF THE NORTHWEST
17629 Cedar Springs Lane
Arlington, OR 97812

PORT OF TACOMA
WAD001882984
3400 TAYLOR WAY
TACOMA WA 98421

CERTIFICATE OF DISPOSAL

Chemical Waste Management of the Northwest, Inc., ORD089452353, has received the following waste material:

GENERATOR:	PORT OF TACOMA
MANIFEST #:	010585364JJK
CWM TRACKING ID:	42704401
PROFILE #:	OR321468
LINE ITEM:	9b.1
QUANTITY:	1 DT
RECEIVED DATE:	08/08/13
DISPOSAL PROCESS(ES):	LANDFILL
FINAL DISPOSAL LOCATION:	LANDFILL 13
DISPOSAL DATE:	08/08/13

I certify, on behalf of the above listed treatment facility, that to the best of my knowledge, the above-described waste material was managed in compliance with all applicable laws, regulations, permits and licenses on the date listed above.

Bobbi Jo Galvin

CWMNW RECORDS DEPARTMENT

Date: 08/12/13



CHEMICAL WASTE MANAGEMENT OF THE NORTHWEST
17629 Cedar Springs Lane
Arlington, OR 97812

PORT OF TACOMA
WAD001882984
3400 TAYLOR WAY
TACOMA WA 98421

CERTIFICATE OF DISPOSAL

Chemical Waste Management of the Northwest, Inc., ORD089452353, has received the following waste material:

GENERATOR: PORT OF TACOMA
MANIFEST #: 010585353JJK
CWM TRACKING ID: 42704501
PROFILE #: OR321468
LINE ITEM: 9b.1
QUANTITY: 1 DT
RECEIVED DATE: 08/08/13

DISPOSAL PROCESS(ES): LANDFILL
FINAL DISPOSAL LOCATION: LANDFILL 13
DISPOSAL DATE: 08/08/13

I certify, on behalf of the above listed treatment facility, that to the best of my knowledge, the above-described waste material was managed in compliance with all applicable laws, regulations, permits and licenses on the date listed above.

Robbinto Galvin

CWMNW RECORDS DEPARTMENT

Date: 08/12/13



CHEMICAL WASTE MANAGEMENT OF THE NORTHWEST

17629 Cedar Springs Lane
Arlington, OR 97812

PORT OF TACOMA
WAD001882984
3400 TAYLOR WAY
TACOMA WA 98421

CERTIFICATE OF DISPOSAL

Chemical Waste Management of the Northwest, Inc., ORD089452353, has received the following waste material:

GENERATOR:	PORT OF TACOMA
MANIFEST #:	010585354JJK
CWM TRACKING ID:	42704601
PROFILE #:	OR321468
LINE ITEM:	9b.1
QUANTITY:	1 DT
RECEIVED DATE:	08/08/13
DISPOSAL PROCESS(ES):	LANDFILL
FINAL DISPOSAL LOCATION:	LANDFILL 13
DISPOSAL DATE:	08/08/13

I certify, on behalf of the above listed treatment facility, that to the best of my knowledge, the above-described waste material was managed in compliance with all applicable laws, regulations, permits and licenses on the date listed above.

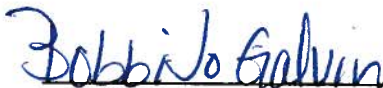

CWMNW RECORDS DEPARTMENT

Date: 08/12/13



CHEMICAL WASTE MANAGEMENT OF THE NORTHWEST
17629 Cedar Springs Lane
Arlington, OR 97812

PORT OF TACOMA
WAD001882984
3400 TAYLOR WAY
TACOMA WA 98421

CERTIFICATE OF DISPOSAL

Chemical Waste Management of the Northwest, Inc., ORD089452353, has received the following waste material:

GENERATOR:	PORT OF TACOMA
MANIFEST #:	010585357JJK
CWM TRACKING ID:	42704701
PROFILE #:	OR321468
LINE ITEM:	9b.1
QUANTITY:	1 DT
RECEIVED DATE:	08/08/13
DISPOSAL PROCESS(ES):	LANDFILL
FINAL DISPOSAL LOCATION:	LANDFILL 13
DISPOSAL DATE:	08/08/13

I certify, on behalf of the above listed treatment facility, that to the best of my knowledge, the above-described waste material was managed in compliance with all applicable laws, regulations, permits and licenses on the date listed above.



CWMNW RECORDS DEPARTMENT

Date: 08/12/13



CHEMICAL WASTE MANAGEMENT OF THE NORTHWEST
17629 Cedar Springs Lane
Arlington, OR 97812

PORT OF TACOMA
WAD001882984
3400 TAYLOR WAY
TACOMA WA 98421

CERTIFICATE OF DISPOSAL

Chemical Waste Management of the Northwest, Inc., ORD089452353, has received the following waste material:

GENERATOR:	PORT OF TACOMA
MANIFEST #:	010585358JJK
CWM TRACKING ID:	42404801
PROFILE #:	OR321468
LINE ITEM:	9b.1
QUANTITY:	1 DT
RECEIVED DATE:	08/08/13
DISPOSAL PROCESS(ES):	LANDFILL
FINAL DISPOSAL LOCATION:	LANDFILL 13
DISPOSAL DATE:	08/08/13

I certify, on behalf of the above listed treatment facility, that to the best of my knowledge, the above-described waste material was managed in compliance with all applicable laws, regulations, permits and licenses on the date listed above.

CWMNW RECORDS DEPARTMENT

Date: 08/12/13



CHEMICAL WASTE MANAGEMENT OF THE NORTHWEST

17629 Cedar Springs Lane
Arlington, OR 97812

PORT OF TACOMA
WAD001882984
3400 TAYLOR WAY
TACOMA WA 98421

CERTIFICATE OF DISPOSAL

Chemical Waste Management of the Northwest, Inc., ORD089452353, has received the following waste material:

GENERATOR: PORT OF TACOMA
MANIFEST #: 010585356JJK
CWM TRACKING ID: 42705001
PROFILE #: OR321468
LINE ITEM: 9b.1
QUANTITY: 1 DT
RECEIVED DATE: 08/08/13

DISPOSAL PROCESS(ES): LANDFILL
FINAL DISPOSAL LOCATION: LANDFILL 13
DISPOSAL DATE: 08/08/13

I certify, on behalf of the above listed treatment facility, that to the best of my knowledge, the above-described waste material was managed in compliance with all applicable laws, regulations, permits and licenses on the date listed above.

Bobbie G. Givins

CWMNW RECORDS DEPARTMENT

Date: 08/12/13



CHEMICAL WASTE MANAGEMENT OF THE NORTHWEST

17629 Cedar Springs Lane
Arlington, OR 97812

PORT OF TACOMA
WAD001882984
3400 TAYLOR WAY
TACOMA WA 98421

CERTIFICATE OF DISPOSAL

Chemical Waste Management of the Northwest, Inc., ORD089452353, has received the following waste material:

GENERATOR:	PORT OF TACOMA
MANIFEST #:	010585362JJK
CWM TRACKING ID:	42703201
PROFILE #:	OR321468
LINE ITEM:	9b.1
QUANTITY:	1 DT
RECEIVED DATE:	08/08/13
DISPOSAL PROCESS(ES):	LANDFILL
FINAL DISPOSAL LOCATION:	LANDFILL 13
DISPOSAL DATE:	08/08/13

I certify, on behalf of the above listed treatment facility, that to the best of my knowledge, the above-described waste material was managed in compliance with all applicable laws, regulations, permits and licenses on the date listed above.



CWMNW RECORDS DEPARTMENT

Date: 08/12/13



CHEMICAL WASTE MANAGEMENT OF THE NORTHWEST
17629 Cedar Springs Lane
Arlington, OR 97812

PORT OF TACOMA
WAD001882984
3400 TAYLOR WAY
TACOMA WA 98421

CERTIFICATE OF DISPOSAL

Chemical Waste Management of the Northwest, Inc., ORD089452353, has received the following waste material:

GENERATOR:	PORT OF TACOMA
MANIFEST #:	010585361JJK
CWM TRACKING ID:	42703301
PROFILE #:	OR321468
LINE ITEM:	9b.1
QUANTITY:	1 DT
RECEIVED DATE:	08/08/13
DISPOSAL PROCESS(ES):	LANDFILL
FINAL DISPOSAL LOCATION:	LANDFILL 13
DISPOSAL DATE:	08/08/13

I certify, on behalf of the above listed treatment facility, that to the best of my knowledge, the above-described waste material was managed in compliance with all applicable laws, regulations, permits and licenses on the date listed above.

Bobbi Jo Graham

CWMNW RECORDS DEPARTMENT

Date: 08/12/13



CHEMICAL WASTE MANAGEMENT OF THE NORTHWEST
17629 Cedar Springs Lane
Arlington, OR 97812

PORT OF TACOMA
WAD001882984
3400 TAYLOR WAY
TACOMA WA 98421

CERTIFICATE OF DISPOSAL

Chemical Waste Management of the Northwest, Inc., ORD089452353, has received the following waste material:

GENERATOR:	PORT OF TACOMA
MANIFEST #:	010585348JJK
CWM TRACKING ID:	42707801
PROFILE #:	OR321468
LINE ITEM:	9b.1
QUANTITY:	1 DT
RECEIVED DATE:	08/09/13
DISPOSAL PROCESS(ES):	LANDFILL
FINAL DISPOSAL LOCATION:	LANDFILL 13
DISPOSAL DATE:	08/09/13

I certify, on behalf of the above listed treatment facility, that to the best of my knowledge, the above-described waste material was managed in compliance with all applicable laws, regulations, permits and licenses on the date listed above.

Robbi Jo Galvin

CWMNW RECORDS DEPARTMENT

Date: 08/13/13



CHEMICAL WASTE MANAGEMENT OF THE NORTHWEST
17629 Cedar Springs Lane
Arlington, OR 97812

PORT OF TACOMA
WAD001882984
3400 TAYLOR WAY
TACOMA WA 98421

CERTIFICATE OF DISPOSAL

Chemical Waste Management of the Northwest, Inc., ORD089452353, has received the following waste material:

GENERATOR:	PORT OF TACOMA
MANIFEST #:	010585334JJK
CWM TRACKING ID:	42707901
PROFILE #:	OR321468
LINE ITEM:	9b.1
QUANTITY:	1 DT
RECEIVED DATE:	08/09/13
DISPOSAL PROCESS(ES):	LANDFILL
FINAL DISPOSAL LOCATION:	LANDFILL 13
DISPOSAL DATE:	08/09/13

I certify, on behalf of the above listed treatment facility, that to the best of my knowledge, the above-described waste material was managed in compliance with all applicable laws, regulations, permits and licenses on the date listed above.

Bobbi Jo Galvin

CWMNW RECORDS DEPARTMENT

Date: 08/13/13



CHEMICAL WASTE MANAGEMENT OF THE NORTHWEST
17629 Cedar Springs Lane
Arlington, OR 97812

PORT OF TACOMA
WAD001882984
3400 TAYLOR WAY
TACOMA WA 98421

CERTIFICATE OF DISPOSAL

Chemical Waste Management of the Northwest, Inc., ORD089452353, has received the following waste material:

GENERATOR:	PORT OF TACOMA
MANIFEST #:	010585335JJK
CWM TRACKING ID:	42708001
PROFILE #:	OR321468
LINE ITEM:	9b.1
QUANTITY:	1 DT
RECEIVED DATE:	08/09/13
DISPOSAL PROCESS(ES):	LANDFILL
FINAL DISPOSAL LOCATION:	LANDFILL 13
DISPOSAL DATE:	08/09/13

I certify, on behalf of the above listed treatment facility, that to the best of my knowledge, the above-described waste material was managed in compliance with all applicable laws, regulations, permits and licenses on the date listed above.



CWMNW RECORDS DEPARTMENT

Date: 08/13/13



CHEMICAL WASTE MANAGEMENT OF THE NORTHWEST
17629 Cedar Springs Lane
Arlington, OR 97812

PORT OF TACOMA
WAD001882984
3400 TAYLOR WAY
TACOMA WA 98421

CERTIFICATE OF DISPOSAL

Chemical Waste Management of the Northwest, Inc., ORD089452353, has received the following waste material:

GENERATOR:	PORT OF TACOMA	
MANIFEST #:	010585349JJK	
CWM TRACKING ID:	42708101	
PROFILE #:	OR321468	
LINE ITEM:	9b.1	
QUANTITY:	1 DT	
RECEIVED DATE:	08/09/13	
DISPOSAL PROCESS(ES):	LANDFILL	
FINAL DISPOSAL LOCATION:	LANDFILL	13
DISPOSAL DATE:	08/09/13	

I certify, on behalf of the above listed treatment facility, that to the best of my knowledge, the above-described waste material was managed in compliance with all applicable laws, regulations, permits and licenses on the date listed above.



CWMNW RECORDS DEPARTMENT

Date: 08/13/13



CHEMICAL WASTE MANAGEMENT OF THE NORTHWEST
17629 Cedar Springs Lane
Arlington, OR 97812

PORT OF TACOMA
WAD001882984
3400 TAYLOR WAY
TACOMA WA 98421

CERTIFICATE OF DISPOSAL

Chemical Waste Management of the Northwest, Inc., ORD089452353, has received the following waste material:

GENERATOR:	PORT OF TACOMA
MANIFEST #:	010585332JJK
CWM TRACKING ID:	42708201
PROFILE #:	OR321468
LINE ITEM:	9b.1
QUANTITY:	1 DT
RECEIVED DATE:	08/09/13
DISPOSAL PROCESS(ES):	LANDFILL
FINAL DISPOSAL LOCATION:	LANDFILL 13
DISPOSAL DATE:	08/09/13

I certify, on behalf of the above listed treatment facility, that to the best of my knowledge, the above-described waste material was managed in compliance with all applicable laws, regulations, permits and licenses on the date listed above.

Bobbi Jotkovic

CWMNW RECORDS DEPARTMENT

Date: 08/13/13



CHEMICAL WASTE MANAGEMENT OF THE NORTHWEST
17629 Cedar Springs Lane
Arlington, OR 97812

PORT OF TACOMA
WAD001882984
3400 TAYLOR WAY
TACOMA WA 98421

CERTIFICATE OF DISPOSAL

Chemical Waste Management of the Northwest, Inc., ORD089452353, has received the following waste material:

GENERATOR:	PORT OF TACOMA
MANIFEST #:	010585333JJK
CWM TRACKING ID:	42708401
PROFILE #:	OR321468
LINE ITEM:	9b.1
QUANTITY:	1 DT
RECEIVED DATE:	08/09/13

DISPOSAL PROCESS(ES):	LANDFILL	
FINAL DISPOSAL LOCATION:	LANDFILL	13
DISPOSAL DATE:	08/09/13	

I certify, on behalf of the above listed treatment facility, that to the best of my knowledge, the above-described waste material was managed in compliance with all applicable laws, regulations, permits and licenses on the date listed above.

Bobbi Jo Galvin

CWMNW RECORDS DEPARTMENT

Date: 08/13/13



CHEMICAL WASTE MANAGEMENT OF THE NORTHWEST
17629 Cedar Springs Lane
Arlington, OR 97812

PORT OF TACOMA
WAD001882984
3400 TAYLOR WAY
TACOMA WA 98421

CERTIFICATE OF DISPOSAL

Chemical Waste Management of the Northwest, Inc., ORD089452353, has received the following waste material:

GENERATOR: PORT OF TACOMA
MANIFEST #: 010585338JJK
CWM TRACKING ID: 42708501
PROFILE #: OR321468
LINE ITEM: 9b.1
QUANTITY: 1 DT
RECEIVED DATE: 08/09/13

DISPOSAL PROCESS(ES): LANDFILL
FINAL DISPOSAL LOCATION: LANDFILL 13
DISPOSAL DATE: 08/09/13

I certify, on behalf of the above listed treatment facility, that to the best of my knowledge, the above-described waste material was managed in compliance with all applicable laws, regulations, permits and licenses on the date listed above.



CWMNW RECORDS DEPARTMENT

Date: 08/13/13



CHEMICAL WASTE MANAGEMENT OF THE NORTHWEST
17629 Cedar Springs Lane
Arlington, OR 97812

PORT OF TACOMA
WAD001882984
3400 TAYLOR WAY
TACOMA WA 98421

CERTIFICATE OF DISPOSAL

Chemical Waste Management of the Northwest, Inc., ORD089452353, has received the following waste material:

GENERATOR:	PORT OF TACOMA
MANIFEST #:	010585331JJK
CWM TRACKING ID:	42708601
PROFILE #:	OR321468
LINE ITEM:	9b.1
QUANTITY:	1 D ³
RECEIVED DATE:	08/09/13
DISPOSAL PROCESS(ES):	LANDFILL
FINAL DISPOSAL LOCATION:	LANDFILL 13
DISPOSAL DATE:	08/09/13

I certify, on behalf of the above listed treatment facility, that to the best of my knowledge, the above-described waste material was managed in compliance with all applicable laws, regulations, permits and licenses on the date listed above.

Bobbi Jo Galvin

CWMNW RECORDS DEPARTMENT

Date: 08/13/13



CHEMICAL WASTE MANAGEMENT OF THE NORTHWEST

17629 Cedar Springs Lane
Arlington, OR 97812

PORT OF TACOMA
WAD001882984
3400 TAYLOR WAY
TACOMA WA 98421

CERTIFICATE OF DISPOSAL

Chemical Waste Management of the Northwest, Inc., ORD089452353, has received the following waste material:

GENERATOR:	PORT OF TACOMA
MANIFEST #:	010585347JJK
CWM TRACKING ID:	42708801
PROFILE #:	OR321468
LINE ITEM:	9b.1
QUANTITY:	1 DT
RECEIVED DATE:	08/09/13
DISPOSAL PROCESS(ES):	LANDFILL
FINAL DISPOSAL LOCATION:	LANDFILL 13
DISPOSAL DATE:	08/09/13

I certify, on behalf of the above listed treatment facility, that to the best of my knowledge, the above-described waste material was managed in compliance with all applicable laws, regulations, permits and licenses on the date listed above.

Bobbi Jo Galvin

CWMNW RECORDS DEPARTMENT

Date: 08/13/13



CHEMICAL WASTE MANAGEMENT OF THE NORTHWEST
17629 Cedar Springs Lane
Arlington, OR 97812

PORT OF TACOMA
WAD001882984
3400 TAYLOR WAY
TACOMA WA 98421

CERTIFICATE OF DISPOSAL

Chemical Waste Management of the Northwest, Inc., ORD089452353, has received the following waste material:

GENERATOR:	PORT OF TACOMA
MANIFEST #:	010585337JJK
CWM TRACKING ID:	42708901
PROFILE #:	OR321468
LINE ITEM:	9b.1
QUANTITY:	1 DT
RECEIVED DATE:	08/09/13
DISPOSAL PROCESS(ES):	LANDFILL
FINAL DISPOSAL LOCATION:	LANDFILL 13
DISPOSAL DATE:	08/09/13

I certify, on behalf of the above listed treatment facility, that to the best of my knowledge, the above-described waste material was managed in compliance with all applicable laws, regulations, permits and licenses on the date listed above.

Bobbi Jo Galvin

CWMNW RECORDS DEPARTMENT

Date: 08/13/13



CHEMICAL WASTE MANAGEMENT OF THE NORTHWEST
17629 Cedar Springs Lane
Arlington, OR 97812

PORT OF TACOMA
WAD001882984
3400 TAYLOR WAY
TACOMA WA 98421

CERTIFICATE OF DISPOSAL

Chemical Waste Management of the Northwest, Inc., ORD089452353, has received the following waste material:

GENERATOR:	PORT OF TACOMA
MANIFEST #:	010585351JJK
CWM TRACKING ID:	42707301
PROFILE #:	OR321468
LINE ITEM:	9b.1
QUANTITY:	1 DT
RECEIVED DATE:	08/09/13
DISPOSAL PROCESS(ES):	LANDFILL
FINAL DISPOSAL LOCATION:	LANDFILL 13
DISPOSAL DATE:	08/09/13

I certify, on behalf of the above listed treatment facility, that to the best of my knowledge, the above-described waste material was managed in compliance with all applicable laws, regulations, permits and licenses on the date listed above.



CWMNW RECORDS DEPARTMENT

Date: 08/13/13



CHEMICAL WASTE MANAGEMENT OF THE NORTHWEST
17629 Cedar Springs Lane
Arlington, OR 97812

PORT OF TACOMA
WAD001882984
3400 TAYLOR WAY
TACOMA WA 98421

CERTIFICATE OF DISPOSAL

Chemical Waste Management of the Northwest, Inc., ORD089452353, has received the following waste material:

GENERATOR:	PORT OF TACOMA
MANIFEST #:	010585350JJK
CWM TRACKING ID:	42707401
PROFILE #:	OR321468
LINE ITEM:	9b.1
QUANTITY:	1 DT
RECEIVED DATE:	08/09/13
DISPOSAL PROCESS(ES):	LANDFILL
FINAL DISPOSAL LOCATION:	LANDFILL 13
DISPOSAL DATE:	08/09/13

I certify, on behalf of the above listed treatment facility, that to the best of my knowledge, the above-described waste material was managed in compliance with all applicable laws, regulations, permits and licenses on the date listed above.



CWMNW RECORDS DEPARTMENT

Date: 08/13/13



CHEMICAL WASTE MANAGEMENT OF THE NORTHWEST
17629 Cedar Springs Lane
Arlington, OR 97812

PORT OF TACOMA
WAD001882984
3400 TAYLOR WAY
TACOMA WA 98421

CERTIFICATE OF DISPOSAL

Chemical Waste Management of the Northwest, Inc., ORD089452353, has received the following waste material:

GENERATOR: PORT OF TACOMA
MANIFEST #: 010585352JJK
CWM TRACKING ID: 42707601
PROFILE #: OR321468
LINE ITEM: 9b.1
QUANTITY: 1 DT
RECEIVED DATE: 08/09/13

DISPOSAL PROCESS(ES): LANDFILL
FINAL DISPOSAL LOCATION: LANDFILL 13
DISPOSAL DATE: 08/09/13

I certify, on behalf of the above listed treatment facility, that to the best of my knowledge, the above-described waste material was managed in compliance with all applicable laws, regulations, permits and licenses on the date listed above.



CWMNW RECORDS DEPARTMENT

Date: 08/13/13



CHEMICAL WASTE MANAGEMENT OF THE NORTHWEST

17629 Cedar Springs Lane
Arlington, OR 97812

PORT OF TACOMA
WAD001882984
3400 TAYLOR WAY
TACOMA WA 98421

CERTIFICATE OF DISPOSAL

Chemical Waste Management of the Northwest, Inc., ORD089452353, has received the following waste material:

GENERATOR:	PORT OF TACOMA
MANIFEST #:	010585355JJK
CWM TRACKING ID:	42705801
PROFILE #:	OR321468
LINE ITEM:	9b.1
QUANTITY:	1 D7
RECEIVED DATE:	08/09/13

DISPOSAL PROCESS(ES):	LANDFILL	
FINAL DISPOSAL LOCATION:	LANDFILL	13
DISPOSAL DATE:	08/09/13	

I certify, on behalf of the above listed treatment facility, that to the best of my knowledge, the above-described waste material was managed in compliance with all applicable laws, regulations, permits and licenses on the date listed above.



CWMNW RECORDS DEPARTMENT

Date: 08/13/13



CHEMICAL WASTE MANAGEMENT OF THE NW
17629 Cedar Springs Lane
Arlington, OR 97812
(541) 454-2643
(541) 454-3279 Fax

PORT OF TACOMA
WAD001882984
3400 TAYLOR WAY
TACOMA WA 98421

CERTIFICATE OF DISPOSAL

Chemical Waste Management of the Northwest, Inc., ORD089452353, has received the following waste material:

GENERATOR:	PORT OF TACOMA
MANIFEST #:	010585406JJK
CWM TRACKING ID:	42711301
PROFILE #:	OR321468
LINE ITEM:	9b.1
QUANTITY:	1 DT
RECEIVED DATE:	08/12/13
DISPOSAL PROCESS(ES):	LANDFILL
FINAL DISPOSAL LOCATION:	LANDFILL 13
DISPOSAL DATE:	08/12/13

I certify, on behalf of the above listed treatment facility, that to the best of my knowledge, the above-described waste material was managed in compliance with all applicable laws, regulations, permits and licenses on the date listed above.

CWMNW RECORDS DEPARTMENT

Date: 08/12/13



CHEMICAL WASTE MANAGEMENT OF THE NW
17629 Cedar Springs Lane
Arlington, OR 97812
(541) 454-2643
(541) 454-3279 Fax

PORT OF TACOMA
WAD001882984
3400 TAYLOR WAY
TACOMA WA 98421

CERTIFICATE OF DISPOSAL

Chemical Waste Management of the Northwest, Inc., ORD089452353, has received the following waste material:

GENERATOR:	PORT OF TACOMA
MANIFEST #:	010585420JJK
CWM TRACKING ID:	42711201
PROFILE #:	OR321468
LINE ITEM:	9b.1
QUANTITY:	1 DT
RECEIVED DATE:	08/12/13
DISPOSAL PROCESS(ES):	LANDFILL
FINAL DISPOSAL LOCATION:	LANDFILL 13
DISPOSAL DATE:	08/12/13

I certify, on behalf of the above listed treatment facility, that to the best of my knowledge, the above-described waste material was managed in compliance with all applicable laws, regulations, permits and licenses on the date listed above.



CWMNW RECORDS DEPARTMENT
Date: 08/12/13



CHEMICAL WASTE MANAGEMENT OF THE NW

17629 Cedar Springs Lane
Arlington, OR 97812
(541) 454-2643
(541) 454-3279 Fax

PORT OF TACOMA
WAD001882984
3400 TAYLOR WAY
TACOMA WA 98421

CERTIFICATE OF DISPOSAL

Chemical Waste Management of the Northwest, Inc., ORD089452353, has received the following waste material:

GENERATOR:	PORT OF TACOMA
MANIFEST #:	010585419JJK
CWM TRACKING ID:	42711101
PROFILE #:	OR321468
LINE ITEM:	9b.1
QUANTITY:	1 DT
RECEIVED DATE:	08/12/13
DISPOSAL PROCESS(ES):	LANDFILL
FINAL DISPOSAL LOCATION:	LANDFILL 13
DISPOSAL DATE:	08/12/13

I certify, on behalf of the above listed treatment facility, that to the best of my knowledge, the above-described waste material was managed in compliance with all applicable laws, regulations, permits and licenses on the date listed above.

Bobbi Jo Galvin

CWMNW RECORDS DEPARTMENT

Date: 08/12/13



CHEMICAL WASTE MANAGEMENT OF THE NORTHWEST

17629 Cedar Springs Lane
Arlington, OR 97812

PORT OF TACOMA
WAD001882984
3400 TAYLOR WAY
TACOMA WA 98421

CERTIFICATE OF DISPOSAL

Chemical Waste Management of the Northwest, Inc., ORD089452353, has received the following waste material:

GENERATOR: PORT OF TACOMA
MANIFEST #: 010585417JJK
CWM TRACKING ID: 42711001
PROFILE #: OR321468
LINE ITEM: 9b.1
QUANTITY: 1 DT
RECEIVED DATE: 08/12/13

DISPOSAL PROCESS(ES): LANDFILL
FINAL DISPOSAL LOCATION: LANDFILL 13
DISPOSAL DATE: 08/12/13

I certify, on behalf of the above listed treatment facility, that to the best of my knowledge, the above-described waste material was managed in compliance with all applicable laws, regulations, permits and licenses on the date listed above.



CWMNW RECORDS DEPARTMENT

Date: 08/12/13



CHEMICAL WASTE MANAGEMENT OF THE NORTHWEST
17629 Cedar Springs Lane
Arlington, OR 97812

PORT OF TACOMA
WAD001882984
3400 TAYLOR WAY
TACOMA WA 98421

CERTIFICATE OF DISPOSAL

Chemical Waste Management of the Northwest, Inc., ORD089452353, has received the following waste material:

GENERATOR:	PORT OF TACOMA
MANIFEST #:	010585412JJK
CWM TRACKING ID:	42710901
PROFILE #:	OR321468
LINE ITEM:	9b.1
QUANTITY:	1 DT
RECEIVED DATE:	08/12/13
DISPOSAL PROCESS(ES):	LANDFILL
FINAL DISPOSAL LOCATION:	LANDFILL 13
DISPOSAL DATE:	08/12/13

I certify, on behalf of the above listed treatment facility, that to the best of my knowledge, the above-described waste material was managed in compliance with all applicable laws, regulations, permits and licenses on the date listed above.



CWMNW RECORDS DEPARTMENT

Date: 08/12/13



CHEMICAL WASTE MANAGEMENT OF THE NORTHWEST
17629 Cedar Springs Lane
Arlington, OR 97812

PORT OF TACOMA
WAD001882984
3400 TAYLOR WAY
TACOMA WA 98421

CERTIFICATE OF DISPOSAL

Chemical Waste Management of the Northwest, Inc., ORD089452353, has received the following waste material:

GENERATOR: PORT OF TACOMA
MANIFEST #: 010585346JJK
CWM TRACKING ID: 42710801
PROFILE #: OR321468
LINE ITEM: 9b.1
QUANTITY: 1 DT
RECEIVED DATE: 08/12/13

DISPOSAL PROCESS(ES): LANDFILL
FINAL DISPOSAL LOCATION: LANDFILL 13
DISPOSAL DATE: 08/12/13

I certify, on behalf of the above listed treatment facility, that to the best of my knowledge, the above-described waste material was managed in compliance with all applicable laws, regulations, permits and licenses on the date listed above.



CWMNW RECORDS DEPARTMENT

Date: 08/12/13



CHEMICAL WASTE MANAGEMENT OF THE NORTHWEST
17629 Cedar Springs Lane
Arlington, OR 97812

PORT OF TACOMA
WAD001882984
3400 TAYLOR WAY
TACOMA WA 98421

CERTIFICATE OF DISPOSAL

Chemical Waste Management of the Northwest, Inc., ORD089452353, has received the following waste material:

GENERATOR: PORT OF TACOMA
MANIFEST #: 010585418JJK
CWM TRACKING ID: 42710701
PROFILE #: OR321468
LINE ITEM: 9b.1
QUANTITY: 1 DT
RECEIVED DATE: 08/12/13

DISPOSAL PROCESS(ES): LANDFILL
FINAL DISPOSAL LOCATION: LANDFILL 13
DISPOSAL DATE: 08/12/13

I certify, on behalf of the above listed treatment facility, that to the best of my knowledge, the above-described waste material was managed in compliance with all applicable laws, regulations, permits and licenses on the date listed above.



CWMNW RECORDS DEPARTMENT

Date: 08/12/13



CHEMICAL WASTE MANAGEMENT OF THE NORTHWEST
17629 Cedar Springs Lane
Arlington, OR 97812

PORT OF TACOMA
WAD001882984
3400 TAYLOR WAY
TACOMA WA 98421

CERTIFICATE OF DISPOSAL

Chemical Waste Management of the Northwest, Inc., ORD089452353, has received the following waste material:

GENERATOR:	PORT OF TACOMA
MANIFEST #:	010585411JJK
CWM TRACKING ID:	42710101
PROFILE #:	OR321468
LINE ITEM:	9b.1
QUANTITY:	1 DT
RECEIVED DATE:	08/12/13
DISPOSAL PROCESS(ES):	LANDFILL
FINAL DISPOSAL LOCATION:	LANDFILL 13
DISPOSAL DATE:	08/12/13

I certify, on behalf of the above listed treatment facility, that to the best of my knowledge, the above-described waste material was managed in compliance with all applicable laws, regulations, permits and licenses on the date listed above.



CWMNW RECORDS DEPARTMENT

Date: 08/12/13



CHEMICAL WASTE MANAGEMENT OF THE NORTHWEST
17629 Cedar Springs Lane
Arlington, OR 97812

PORT OF TACOMA
WAD001882984
3400 TAYLOR WAY
TACOMA WA 98421

CERTIFICATE OF DISPOSAL

Chemical Waste Management of the Northwest, Inc., ORD089452353, has received the following waste material:

GENERATOR:	PORT OF TACOMA
MANIFEST #:	010585410JJK
CWM TRACKING ID:	42709801
PROFILE #:	OR321468
LINE ITEM:	9b.1
QUANTITY:	1 DT
RECEIVED DATE:	08/12/13
DISPOSAL PROCESS(ES):	LANDFILL
FINAL DISPOSAL LOCATION:	LANDFILL 13
DISPOSAL DATE:	08/12/13

I certify, on behalf of the above listed treatment facility, that to the best of my knowledge, the above-described waste material was managed in compliance with all applicable laws, regulations, permits and licenses on the date listed above.



CWMNW RECORDS DEPARTMENT

Date: 08/12/13



CHEMICAL WASTE MANAGEMENT OF THE NORTHWEST
17629 Cedar Springs Lane
Arlington, OR 97812

PORT OF TACOMA
WAD001882984
3400 TAYLOR WAY
TACOMA WA 98421

CERTIFICATE OF DISPOSAL

Chemical Waste Management of the Northwest, Inc., ORD089452353, has received the following waste material:

GENERATOR:	PORT OF TACOMA
MANIFEST #:	010585407JJJ
CWM TRACKING ID:	42709601
PROFILE #:	OR321468
LINE ITEM:	9b.1
QUANTITY:	1 DT
RECEIVED DATE:	08/12/13
DISPOSAL PROCESS(ES):	LANDFILL
FINAL DISPOSAL LOCATION:	LANDFILL 13
DISPOSAL DATE:	08/12/13

I certify, on behalf of the above listed treatment facility, that to the best of my knowledge, the above-described waste material was managed in compliance with all applicable laws, regulations, permits and licenses on the date listed above.



CWMNW RECORDS DEPARTMENT

Date: 08/12/13



CHEMICAL WASTE MANAGEMENT OF THE NORTHWEST

17629 Cedar Springs Lane
Arlington, OR 97812

PORT OF TACOMA
WAD001882984
3400 TAYLOR WAY
TACOMA WA 98421

CERTIFICATE OF DISPOSAL

Chemical Waste Management of the Northwest, Inc., ORD089452353, has received the following waste material:

GENERATOR:	PORT OF TACOMA
MANIFEST #:	010585409JJK
CWM TRACKING ID:	42709501
PROFILE #:	OR321468
LINE ITEM:	9b.1
QUANTITY:	1 DT
RECEIVED DATE:	08/12/13
DISPOSAL PROCESS(ES):	LANDFILL
FINAL DISPOSAL LOCATION:	LANDFILL 13
DISPOSAL DATE:	08/12/13

I certify, on behalf of the above listed treatment facility, that to the best of my knowledge, the above-described waste material was managed in compliance with all applicable laws, regulations, permits and licenses on the date listed above.

CWMNW RECORDS DEPARTMENT

Date: 08/12/13



CHEMICAL WASTE MANAGEMENT OF THE NORTHWEST
17629 Cedar Springs Lane
Arlington, OR 97812

PORT OF TACOMA
WAD001882984
3400 TAYLOR WAY
TACOMA WA 98421

CERTIFICATE OF DISPOSAL

Chemical Waste Management of the Northwest, Inc., ORD089452353, has received the following waste material:

GENERATOR:	PORT OF TACOMA
MANIFEST #:	010585408JJK
CWM TRACKING ID:	42709401
PROFILE #:	OR321468
LINE ITEM:	9b.1
QUANTITY:	1 DT
RECEIVED DATE:	08/12/13
DISPOSAL PROCESS(ES):	LANDFILL
FINAL DISPOSAL LOCATION:	LANDFILL 13
DISPOSAL DATE:	08/12/13

I certify, on behalf of the above listed treatment facility, that to the best of my knowledge, the above-described waste material was managed in compliance with all applicable laws, regulations, permits and licenses on the date listed above.



CWMNW RECORDS DEPARTMENT

Date: 08/12/13



CHEMICAL WASTE MANAGEMENT OF THE NW
17629 Cedar Springs Lane
Arlington, OR 97812
(541) 454-2643
(541) 454-3279 Fax

PORT OF TACOMA
WAD001882984
3400 TAYLOR WAY
TACOMA WA 98421

CERTIFICATE OF DISPOSAL

Chemical Waste Management of the Northwest, Inc., ORD089452353, has received the following waste material:

GENERATOR:	PORT OF TACOMA
MANIFEST #:	010585404JJK
CWM TRACKING ID:	42711401
PROFILE #:	OR321468
LINE ITEM:	9b.1
QUANTITY:	1 DT
RECEIVED DATE:	08/12/13
DISPOSAL PROCESS(ES):	LANDFILL
FINAL DISPOSAL LOCATION:	LANDFILL 13
DISPOSAL DATE:	08/12/13

I certify, on behalf of the above listed treatment facility, that to the best of my knowledge, the above-described waste material was managed in compliance with all applicable laws, regulations, permits and licenses on the date listed above.

CWMNW RECORDS DEPARTMENT

Date: 08/16/13



CHEMICAL WASTE MANAGEMENT OF THE NW

17629 Cedar Springs Lane
Arlington, OR 97812
(541) 454-2643
(541) 454-3279 Fax

PORT OF TACOMA
WAD001882984
3400 TAYLOR WAY
TACOMA WA 98421

CERTIFICATE OF DISPOSAL

Chemical Waste Management of the Northwest, Inc., ORD089452353, has received the following waste material:

GENERATOR:	PORT OF TACOMA
MANIFEST #:	010585405JJK
CWM TRACKING ID:	42711501
PROFILE #:	OR321468
LINE ITEM:	9b.1
QUANTITY:	1 DT
RECEIVED DATE:	08/12/13
DISPOSAL PROCESS(ES):	LANDFILL
FINAL DISPOSAL LOCATION:	LANDFILL 13
DISPOSAL DATE:	08/12/13

I certify, on behalf of the above listed treatment facility, that to the best of my knowledge, the above-described waste material was managed in compliance with all applicable laws, regulations, permits and licenses on the date listed above.



CWMNW RECORDS DEPARTMENT

Date: 08/16/13



CHEMICAL WASTE MANAGEMENT OF THE NW

17629 Cedar Springs Lane
Arlington, OR 97812
(541) 454-2643
(541) 454-3279 Fax

PORT OF TACOMA
WAD001882984
3400 TAYLOR WAY
TACOMA WA 98421

CERTIFICATE OF DISPOSAL

Chemical Waste Management of the Northwest, Inc., ORD089452353, has received the following waste material:

GENERATOR:	PORT OF TACOMA
MANIFEST #:	010585343JJK
CWM TRACKING ID:	42714101
PROFILE #:	OR321468
LINE ITEM:	9b.1
QUANTITY:	1 DT
RECEIVED DATE:	08/13/13
DISPOSAL PROCESS(ES):	LANDFILL
FINAL DISPOSAL LOCATION:	LANDFILL 13
DISPOSAL DATE:	08/13/13

I certify, on behalf of the above listed treatment facility, that to the best of my knowledge, the above-described waste material was managed in compliance with all applicable laws, regulations, permits and licenses on the date listed above.



CWMNW RECORDS DEPARTMENT

Date: 08/16/13



CHEMICAL WASTE MANAGEMENT OF THE NW

17629 Cedar Springs Lane
Arlington, OR 97812
(541) 454-2643
(541) 454-3279 Fax

PORT OF TACOMA
WAD001882984
3400 TAYLOR WAY
TACOMA WA 98421

CERTIFICATE OF DISPOSAL

Chemical Waste Management of the Northwest, Inc., ORD089452353, has received the following waste material:

GENERATOR:	PORT OF TACOMA
MANIFEST #:	010585391JJK
CWM TRACKING ID:	42714201
PROFILE #:	OR321468
LINE ITEM:	9b.1
QUANTITY:	1 DT
RECEIVED DATE:	08/13/13
DISPOSAL PROCESS(ES):	LANDFILL
FINAL DISPOSAL LOCATION:	LANDFILL 13
DISPOSAL DATE:	08/13/13

I certify, on behalf of the above listed treatment facility, that to the best of my knowledge, the above-described waste material was managed in compliance with all applicable laws, regulations, permits and licenses on the date listed above.



CWMNW RECORDS DEPARTMENT

Date: 08/16/13



CHEMICAL WASTE MANAGEMENT OF THE NW

17629 Cedar Springs Lane
Arlington, OR 97812
(541) 454-2643
(541) 454-3279 Fax

PORT OF TACOMA
WAD001882984
3400 TAYLOR WAY
TACOMA WA 98421

CERTIFICATE OF DISPOSAL

Chemical Waste Management of the Northwest, Inc., ORD089452353, has received the following waste material:

GENERATOR:	PORT OF TACOMA
MANIFEST #:	010585390JJK
CWM TRACKING ID:	42714301
PROFILE #:	OR321468
LINE ITEM:	9b.1
QUANTITY:	1 DT
RECEIVED DATE:	08/13/13
DISPOSAL PROCESS(ES):	LANDFILL
FINAL DISPOSAL LOCATION:	LANDFILL 13
DISPOSAL DATE:	08/13/13

I certify, on behalf of the above listed treatment facility, that to the best of my knowledge, the above-described waste material was managed in compliance with all applicable laws, regulations, permits and licenses on the date listed above.



CWMNW RECORDS DEPARTMENT

Date: 08/16/13



CHEMICAL WASTE MANAGEMENT OF THE NW

17629 Cedar Springs Lane
Arlington, OR 97812
(541) 454-2643
(541) 454-3279 Fax

PORT OF TACOMA
WAD001882984
3400 TAYLOR WAY
TACOMA WA 98421

CERTIFICATE OF DISPOSAL

Chemical Waste Management of the Northwest, Inc., ORD089452353, has received the following waste material:

GENERATOR:	PORT OF TACOMA
MANIFEST #:	010585393JJK
CWM TRACKING ID:	42714401
PROFILE #:	OR321468
LINE ITEM:	9b.1
QUANTITY:	1 DT
RECEIVED DATE:	08/13/13
DISPOSAL PROCESS(ES):	LANDFILL
FINAL DISPOSAL LOCATION:	LANDFILL 13
DISPOSAL DATE:	08/13/13

I certify, on behalf of the above listed treatment facility, that to the best of my knowledge, the above-described waste material was managed in compliance with all applicable laws, regulations, permits and licenses on the date listed above.



CWMNW RECORDS DEPARTMENT

Date: 08/16/13



CHEMICAL WASTE MANAGEMENT OF THE NW

17629 Cedar Springs Lane
Arlington, OR 97812
(541) 454-2643
(541) 454-3279 Fax

PORT OF TACOMA
WAD001882984
3400 TAYLOR WAY
TACOMA WA 98421

CERTIFICATE OF DISPOSAL

Chemical Waste Management of the Northwest, Inc., ORD089452353, has received the following waste material:

GENERATOR:	PORT OF TACOMA
MANIFEST #:	010585394JJK
CWM TRACKING ID:	42714501
PROFILE #:	OR321468
LINE ITEM:	9b.1
QUANTITY:	1 DT
RECEIVED DATE:	08/13/13
DISPOSAL PROCESS(ES):	LANDFILL
FINAL DISPOSAL LOCATION:	LANDFILL 13
DISPOSAL DATE:	08/13/13

I certify, on behalf of the above listed treatment facility, that to the best of my knowledge, the above-described waste material was managed in compliance with all applicable laws, regulations, permits and licenses on the date listed above.

CWMNW RECORDS DEPARTMENT
Date:

08/16/13



CHEMICAL WASTE MANAGEMENT OF THE NW
17629 Cedar Springs Lane
Arlington, OR 97812
(541) 454-2643
(541) 454-3279 Fax

PORT OF TACOMA
WAD001882984
3400 TAYLOR WAY
TACOMA WA 98421

CERTIFICATE OF DISPOSAL

Chemical Waste Management of the Northwest, Inc., ORD089452353, has received the following waste material:

GENERATOR:	PORT OF TACOMA
MANIFEST #:	010585402JJK
CWM TRACKING ID:	42714701
PROFILE #:	OR321468
LINE ITEM:	9b.1
QUANTITY:	1 DT
RECEIVED DATE:	08/13/13
DISPOSAL PROCESS(ES):	LANDFILL
FINAL DISPOSAL LOCATION:	LANDFILL 13
DISPOSAL DATE:	08/13/13

I certify, on behalf of the above listed treatment facility, that to the best of my knowledge, the above-described waste material was managed in compliance with all applicable laws, regulations, permits and licenses on the date listed above.



CWMNW RECORDS DEPARTMENT

Date: 08/16/13



CHEMICAL WASTE MANAGEMENT OF THE NW

17629 Cedar Springs Lane
Arlington, OR 97812
(541) 454-2643
(541) 454-3279 Fax

PORT OF TACOMA
WAD001882984
3400 TAYLOR WAY
TACOMA WA 98421

CERTIFICATE OF DISPOSAL

Chemical Waste Management of the Northwest, Inc., ORD089452353, has received the following waste material:

GENERATOR:	PORT OF TACOMA
MANIFEST #:	010585395JJK
CWM TRACKING ID:	42714801
PROFILE #:	OR321468
LINE ITEM:	9b.1
QUANTITY:	1 DT
RECEIVED DATE:	08/13/13
DISPOSAL PROCESS(ES):	LANDFILL
FINAL DISPOSAL LOCATION:	LANDFILL 13
DISPOSAL DATE:	08/13/13

I certify, on behalf of the above listed treatment facility, that to the best of my knowledge, the above-described waste material was managed in compliance with all applicable laws, regulations, permits and licenses on the date listed above.



CWMNW RECORDS DEPARTMENT

Date: 08/16/13



CHEMICAL WASTE MANAGEMENT OF THE NW

17629 Cedar Springs Lane
Arlington, OR 97812
(541) 454-2643
(541) 454-3279 Fax

PORT OF TACOMA
WAD001882984
3400 TAYLOR WAY
TACOMA WA 98421

CERTIFICATE OF DISPOSAL

Chemical Waste Management of the Northwest, Inc., ORD089452353, has received the following waste material:

GENERATOR: PORT OF TACOMA
MANIFEST #: 010585392JJK
CWM TRACKING ID: 42713201
PROFILE #: OR321468
LINE ITEM: 9b.1
QUANTITY: 1 DT
RECEIVED DATE: 08/13/13

DISPOSAL PROCESS(ES): LANDFILL
FINAL DISPOSAL LOCATION: LANDFILL 13
DISPOSAL DATE: 08/13/13

I certify, on behalf of the above listed treatment facility, that to the best of my knowledge, the above-described waste material was managed in compliance with all applicable laws, regulations, permits and licenses on the date listed above.



CWMNW RECORDS DEPARTMENT

Date: 08/16/13



CHEMICAL WASTE MANAGEMENT OF THE NW

17629 Cedar Springs Lane
Arlington, OR 97812
(541) 454-2643
(541) 454-3279 Fax

PORT OF TACOMA
WAD001882984
3400 TAYLOR WAY
TACOMA WA 98421

CERTIFICATE OF DISPOSAL

Chemical Waste Management of the Northwest, Inc., ORD089452353, has received the following waste material:

GENERATOR:	PORT OF TACOMA
MANIFEST #:	010585345JJK
CWM TRACKING ID:	42713301
PROFILE #:	OR321468
LINE ITEM:	9b.1
QUANTITY:	1 DT
RECEIVED DATE:	08/13/13
DISPOSAL PROCESS(ES):	LANDFILL
FINAL DISPOSAL LOCATION:	LANDFILL 13
DISPOSAL DATE:	08/13/13

I certify, on behalf of the above listed treatment facility, that to the best of my knowledge, the above-described waste material was managed in compliance with all applicable laws, regulations, permits and licenses on the date listed above.



CWMNW RECORDS DEPARTMENT

Date: 08/16/13



CHEMICAL WASTE MANAGEMENT OF THE NW

17629 Cedar Springs Lane
Arlington, OR 97812
(541) 454-2643
(541) 454-3279 Fax

PORT OF TACOMA
WAD001882984
3400 TAYLOR WAY
TACOMA WA 98421

CERTIFICATE OF DISPOSAL

Chemical Waste Management of the Northwest, Inc., ORD089452353, has received the following waste material:

GENERATOR: PORT OF TACOMA
MANIFEST #: 010585344JJK
CWM TRACKING ID: 42713401
PROFILE #: OR321468
LINE ITEM: 9b.1
QUANTITY: 1 DT
RECEIVED DATE: 08/13/13

DISPOSAL PROCESS(ES): LANDFILL
FINAL DISPOSAL LOCATION: LANDFILL 13
DISPOSAL DATE: 08/13/13

I certify, on behalf of the above listed treatment facility, that to the best of my knowledge, the above-described waste material was managed in compliance with all applicable laws, regulations, permits and licenses on the date listed above.



CWMNW RECORDS DEPARTMENT

Date: 08/16/13



CHEMICAL WASTE MANAGEMENT OF THE NW

17629 Cedar Springs Lane
Arlington, OR 97812
(541) 454-2643
(541) 454-3279 Fax

PORT OF TACOMA
WAD001882984
3400 TAYLOR WAY
TACOMA WA 98421

CERTIFICATE OF DISPOSAL

Chemical Waste Management of the Northwest, Inc., ORD089452353, has received the following waste material:

GENERATOR: PORT OF TACOMA
MANIFEST #: 010585403JJK
CWM TRACKING ID: 42713501
PROFILE #: OR321468
LINE ITEM: 9b.1
QUANTITY: 1 DT
RECEIVED DATE: 08/13/13

DISPOSAL PROCESS(ES): LANDFILL
FINAL DISPOSAL LOCATION: LANDFILL 13
DISPOSAL DATE: 08/13/13

I certify, on behalf of the above listed treatment facility, that to the best of my knowledge, the above-described waste material was managed in compliance with all applicable laws, regulations, permits and licenses on the date listed above.

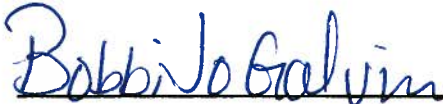

CWMNW RECORDS DEPARTMENT

Date: 08/16/13



CHEMICAL WASTE MANAGEMENT OF THE NW

17629 Cedar Springs Lane
Arlington, OR 97812
(541) 454-2643
(541) 454-3279 Fax

PORT OF TACOMA
WAD001882984
3400 TAYLOR WAY
TACOMA WA 98421

CERTIFICATE OF DISPOSAL

Chemical Waste Management of the Northwest, Inc., ORD089452353, has received the following waste material:

GENERATOR: PORT OF TACOMA
MANIFEST #: 010585342JJK
CWM TRACKING ID: 42713601
PROFILE #: OR021468
LINE ITEM: 9b.1
QUANTITY: 1 DT
RECEIVED DATE: 08/13/13

DISPOSAL PROCESS(ES): LANDFILL
FINAL DISPOSAL LOCATION: LANDFILL 13
DISPOSAL DATE: 08/13/13

I certify, on behalf of the above listed treatment facility, that to the best of my knowledge, the above-described waste material was managed in compliance with all applicable laws, regulations, permits and licenses on the date listed above.

CWMNW RECORDS DEPARTMENT

Date: 08/16/13



CHEMICAL WASTE MANAGEMENT OF THE NW

17629 Cedar Springs Lane
Arlington, OR 97812
(541) 454-2643
(541) 454-3279 Fax

PORT OF TACOMA
WAD001882984
3400 TAYLOR WAY
TACOMA WA 98421

CERTIFICATE OF DISPOSAL

Chemical Waste Management of the Northwest, Inc., ORD089452353, has received the following waste material:

GENERATOR:	PORT OF TACOMA
MANIFEST #:	010585339JJK
CWM TRACKING ID:	42712801
PROFILE #:	OR321468
LINE ITEM:	9b.1
QUANTITY:	1 DT
RECEIVED DATE:	08/13/13
DISPOSAL PROCESS(ES):	LANDFILL
FINAL DISPOSAL LOCATION:	LANDFILL 13
DISPOSAL DATE:	08/13/13

I certify, on behalf of the above listed treatment facility, that to the best of my knowledge, the above-described waste material was managed in compliance with all applicable laws, regulations, permits and licenses on the date listed above.



CWMNW RECORDS DEPARTMENT
Date: 08/16/13



CHEMICAL WASTE MANAGEMENT OF THE NW

17629 Cedar Springs Lane
Arlington, OR 97812
(541) 454-2643
(541) 454-3279 Fax

PORT OF TACOMA
WAD001882984
3400 TAYLOR WAY
TACOMA WA 98421

CERTIFICATE OF DISPOSAL

Chemical Waste Management of the Northwest, Inc., ORD089452353, has received the following waste material:

GENERATOR:	PORT OF TACOMA
MANIFEST #:	010585340JJK
CWM TRACKING ID:	42712901
PROFILE #:	OR321468
LINE ITEM:	9b.1
QUANTITY:	1 DT
RECEIVED DATE:	08/13/13
DISPOSAL PROCESS(ES):	LANDFILL
FINAL DISPOSAL LOCATION:	LANDFILL 13
DISPOSAL DATE:	08/13/13

I certify, on behalf of the above listed treatment facility, that to the best of my knowledge, the above-described waste material was managed in compliance with all applicable laws, regulations, permits and licenses on the date listed above.



CWMNW RECORDS DEPARTMENT
Date: 08/16/13



CHEMICAL WASTE MANAGEMENT OF THE NW

17629 Cedar Springs Lane
Arlington, OR 97812
(541) 454-2643
(541) 454-3279 Fax

PORT OF TACOMA
WAD001882984
3400 TAYLOR WAY
TACOMA WA 98421

CERTIFICATE OF DISPOSAL

Chemical Waste Management of the Northwest, Inc., ORD089452353, has received the following waste material:

GENERATOR:	PORT OF TACOMA
MANIFEST #:	010585382JJK
CWM TRACKING ID:	42718501
PROFILE #:	OR321468
LINE ITEM:	9b.1
QUANTITY:	1 DT
RECEIVED DATE:	08/14/13
DISPOSAL PROCESS(ES):	LANDFILL
FINAL DISPOSAL LOCATION:	LANDFILL 13
DISPOSAL DATE:	08/14/13

I certify, on behalf of the above listed treatment facility, that to the best of my knowledge, the above-described waste material was managed in compliance with all applicable laws, regulations, permits and licenses on the date listed above.

CWMNW RECORDS DEPARTMENT

Date: 08/19/13



CHEMICAL WASTE MANAGEMENT OF THE NW

17629 Cedar Springs Lane
Arlington, OR 97812
(541) 454-2643
(541) 454-3279 Fax

PORT OF TACOMA
WAD001882984
3400 TAYLOR WAY
TACOMA WA 98421

CERTIFICATE OF DISPOSAL

Chemical Waste Management of the Northwest, Inc., ORD089452353, has received the following waste material:

GENERATOR:	PORT OF TACOMA
MANIFEST #:	010585385JJK
CWM TRACKING ID:	42718601
PROFILE #:	OR321468
LINE ITEM:	9b.1
QUANTITY:	1 DT
RECEIVED DATE:	08/14/13
DISPOSAL PROCESS(ES):	LANDFILL
FINAL DISPOSAL LOCATION:	LANDFILL 13
DISPOSAL DATE:	08/14/13

I certify, on behalf of the above listed treatment facility, that to the best of my knowledge, the above-described waste material was managed in compliance with all applicable laws, regulations, permits and licenses on the date listed above.



CWMNW RECORDS DEPARTMENT

Date: 08/19/13



CHEMICAL WASTE MANAGEMENT OF THE NW

17629 Cedar Springs Lane
Arlington, OR 97812
(541) 454-2643
(541) 454-3279 Fax

PORT OF TACOMA
WAD001882984
3400 TAYLOR WAY
TACOMA WA 98421

CERTIFICATE OF DISPOSAL

Chemical Waste Management of the Northwest, Inc., ORD089452353, has received the following waste material:

GENERATOR:	PORT OF TACOMA
MANIFEST #:	010585401JJJ
CWM TRACKING ID:	42718701
PROFILE #:	OR321468
LINE ITEM:	9b.1
QUANTITY:	1 DT
RECEIVED DATE:	08/14/13
DISPOSAL PROCESS(ES):	LANDFILL
FINAL DISPOSAL LOCATION:	LANDFILL 13
DISPOSAL DATE:	08/14/13

I certify, on behalf of the above listed treatment facility, that to the best of my knowledge, the above-described waste material was managed in compliance with all applicable laws, regulations, permits and licenses on the date listed above.

CWMNW RECORDS DEPARTMENT

Date: 08/19/13



CHEMICAL WASTE MANAGEMENT OF THE NW

17629 Cedar Springs Lane
Arlington, OR 97812
(541) 454-2643
(541) 454-3279 Fax

PORT OF TACOMA
WAD001882984
3400 TAYLOR WAY
TACOMA WA 98421

CERTIFICATE OF DISPOSAL

Chemical Waste Management of the Northwest, Inc., ORD089452353, has received the following waste material:

GENERATOR: PORT OF TACOMA
MANIFEST #: 010585384JJK
CWM TRACKING ID: 42718801
PROFILE #: OR321468
LINE ITEM: 9b.1
QUANTITY: 1 DT
RECEIVED DATE: 08/14/13

DISPOSAL PROCESS(ES): LANDFILL
FINAL DISPOSAL LOCATION: LANDFILL 13
DISPOSAL DATE: 08/14/13

I certify, on behalf of the above listed treatment facility, that to the best of my knowledge, the above-described waste material was managed in compliance with all applicable laws, regulations, permits and licenses on the date listed above.

CWMNW RECORDS DEPARTMENT

Date: 08/19/13



CHEMICAL WASTE MANAGEMENT OF THE NW
17629 Cedar Springs Lane
Arlington, OR 97812
(541) 454-2643
(541) 454-3279 Fax

PORT OF TACOMA
WAD001882984
3400 TAYLOR WAY
TACOMA WA 98421

CERTIFICATE OF DISPOSAL

Chemical Waste Management of the Northwest, Inc., ORD089452353, has received the following waste material:

GENERATOR:	PORT OF TACOMA
MANIFEST #:	010585400JJK
CWM TRACKING ID:	42718901
PROFILE #:	OR321468
LINE ITEM:	9b.1
QUANTITY:	1 DT
RECEIVED DATE:	08/14/13
DISPOSAL PROCESS(ES):	LANDFILL
FINAL DISPOSAL LOCATION:	LANDFILL 13
DISPOSAL DATE:	08/14/13

I certify, on behalf of the above listed treatment facility, that to the best of my knowledge, the above-described waste material was managed in compliance with all applicable laws, regulations, permits and licenses on the date listed above.



CWMNW RECORDS DEPARTMENT
Date: 08/19/13



CHEMICAL WASTE MANAGEMENT OF THE NW

17629 Cedar Springs Lane
Arlington, OR 97812
(541) 454-2643
(541) 454-3279 Fax

PORT OF TACOMA
WAD001882984
3400 TAYLOR WAY
TACOMA WA 98421

CERTIFICATE OF DISPOSAL

Chemical Waste Management of the Northwest, Inc., ORD089452353, has received the following waste material:

GENERATOR:	PORT OF TACOMA
MANIFEST #:	010585341JJK
CWM TRACKING ID:	42719101
PROFILE #:	OR321468
LINE ITEM:	9b.1
QUANTITY:	1 DT
RECEIVED DATE:	08/14/13
DISPOSAL PROCESS(ES):	LANDFILL
FINAL DISPOSAL LOCATION:	LANDFILL 13
DISPOSAL DATE:	08/14/13

I certify, on behalf of the above listed treatment facility, that to the best of my knowledge, the above-described waste material was managed in compliance with all applicable laws, regulations, permits and licenses on the date listed above.



CWMNW RECORDS DEPARTMENT

Date: 08/19/13



CHEMICAL WASTE MANAGEMENT OF THE NW
17629 Cedar Springs Lane
Arlington, OR 97812
(541) 454-2643
(541) 454-3279 Fax

PORT OF TACOMA
WAD001882984
3400 TAYLOR WAY
TACOMA WA 98421

RECEIVED
SEP 23 2013
ENGINEERING DEPT.

CERTIFICATE OF DISPOSAL

Chemical Waste Management of the Northwest, Inc., ORD089452353, has received the following waste material:

GENERATOR:	PORT OF TACOMA
MANIFEST #:	010585388JJK
CWM TRACKING ID:	42717301
PROFILE #:	OR321468
LINE ITEM:	9b.1
QUANTITY:	1 DT
RECEIVED DATE:	08/14/13
DISPOSAL PROCESS(ES):	LANDFILL
FINAL DISPOSAL LOCATION:	LANDFILL 13
DISPOSAL DATE:	08/14/13

I certify, on behalf of the above listed treatment facility, that to the best of my knowledge, the above-described waste material was managed in compliance with all applicable laws, regulations, permits and licenses on the date listed above.

 _____

CWMNW RECORDS DEPARTMENT
Date: 08/19/13



CHEMICAL WASTE MANAGEMENT OF THE NW
17629 Cedar Springs Lane
Arlington, OR 97812
(541) 454-2643
(541) 454-3279 Fax

PORT OF TACOMA
WAD001882984
3400 TAYLOR WAY
TACOMA WA 98421

CERTIFICATE OF DISPOSAL

Chemical Waste Management of the Northwest, Inc., ORD089452353, has received the following waste material:

GENERATOR:	PORT OF TACOMA
MANIFEST #:	010585386JJK
CWM TRACKING ID:	42717401
PROFILE #:	OR321468
LINE ITEM:	9b.1
QUANTITY:	1 DT
RECEIVED DATE:	08/14/13
DISPOSAL PROCESS(ES):	LANDFILL
FINAL DISPOSAL LOCATION:	LANDFILL 13
DISPOSAL DATE:	08/14/13

I certify, on behalf of the above listed treatment facility, that to the best of my knowledge, the above-described waste material was managed in compliance with all applicable laws, regulations, permits and licenses on the date listed above.

Bobbie J. Galvin

CWMNW RECORDS DEPARTMENT
Date:

08/13/13



CHEMICAL WASTE MANAGEMENT OF THE NW

17629 Cedar Springs Lane
Arlington, OR 97812
(541) 454-2643
(541) 454-3279 Fax

PORT OF TACOMA
WAD001882984
3400 TAYLOR WAY
TACOMA WA 98421

CERTIFICATE OF DISPOSAL

Chemical Waste Management of the Northwest, Inc., ORD089452353, has received the following waste material:

GENERATOR:	PORT OF TACOMA
MANIFEST #:	010585387JJK
CWM TRACKING ID:	42717501
PROFILE #:	OR 21468
LINE ITEM:	9b.1
QUANTITY:	1 DT
RECEIVED DATE:	08/14/13
DISPOSAL PROCESS(ES):	LANDFILL
FINAL DISPOSAL LOCATION:	LANDFILL 13
DISPOSAL DATE:	08/14/13

I certify, on behalf of the above listed treatment facility, that to the best of my knowledge, the above-described waste material was managed in compliance with all applicable laws, regulations, permits and licenses on the date listed above.

CWMNW RECORDS DEPARTMENT

Date: 08/19/13



CHEMICAL WASTE MANAGEMENT OF THE NW

17629 Cedar Springs Lane
Arlington, OR 97812
(541) 454-2643
(541) 454-3279 Fax

PORT OF TACOMA
WAD001882984
3400 TAYLOR WAY
TACOMA WA 98421

CERTIFICATE OF DISPOSAL

Chemical Waste Management of the Northwest, Inc., ORD089452353, has received the following waste material:

GENERATOR:	PORT OF TACOMA
MANIFEST #:	010585381JJK
CWM TRACKING ID:	42717601
PROFILE #:	OR321468
LINE ITEM:	9b.1
QUANTITY:	1 DT
RECEIVED DATE:	08/14/13
DISPOSAL PROCESS(ES):	LANDFILL
FINAL DISPOSAL LOCATION:	LANDFILL 13
DISPOSAL DATE:	08/14/13

I certify, on behalf of the above listed treatment facility, that to the best of my knowledge, the above-described waste material was managed in compliance with all applicable laws, regulations, permits and licenses on the date listed above.



CWMNW RECORDS DEPARTMENT

Date:

08/19/13



CHEMICAL WASTE MANAGEMENT OF THE NW

17629 Cedar Springs Lane
Arlington, OR 97812
(541) 454-2643
(541) 454-3279 Fax

PORT OF TACOMA
WAD001882984
3400 TAYLOR WAY
TACOMA WA 98421

CERTIFICATE OF DISPOSAL

Chemical Waste Management of the Northwest, Inc., ORD089452353, has received the following waste material:

GENERATOR:	PORT OF TACOMA
MANIFEST #:	010585380JJK
CWM TRACKING ID:	42717801
PROFILE #:	OR321468
LINE ITEM:	9b.1'
QUANTITY:	1 DT
RECEIVED DATE:	08/14/13
DISPOSAL PROCESS(ES):	LANDFILL
FINAL DISPOSAL LOCATION:	LANDFILL 13
DISPOSAL DATE:	08/14/13

I certify, on behalf of the above listed treatment facility, that to the best of my knowledge, the above-described waste material was managed in compliance with all applicable laws, regulations, permits and licenses on the date listed above.

CWMNW RECORDS DEPARTMENT

Date: 08/19/13



CHEMICAL WASTE MANAGEMENT OF THE NW

17629 Cedar Springs Lane
Arlington, OR 97812
(541) 454-2643
(541) 454-3279 Fax

PORT OF TACOMA
WAD001882984
3400 TAYLOR WAY
TACOMA WA 98421

CERTIFICATE OF DISPOSAL

Chemical Waste Management of the Northwest, Inc., ORD089452353, has received the following waste material:

GENERATOR:	PORT OF TACOMA
MANIFEST #:	010585398JJK
CWM TRACKING ID:	42717901
PROFILE #:	OR321468
LINE ITEM:	9b.1
QUANTITY:	1 DT
RECEIVED DATE:	08/14/13
DISPOSAL PROCESS(ES):	LANDFILL
FINAL DISPOSAL LOCATION:	LANDFILL 13
DISPOSAL DATE:	08/14/13

I certify, on behalf of the above listed treatment facility, that to the best of my knowledge, the above-described waste material was managed in compliance with all applicable laws, regulations, permits and licenses on the date listed above.



CWMNW RECORDS DEPARTMENT
Date: 08/19/13



CHEMICAL WASTE MANAGEMENT OF THE NW

17629 Cedar Springs Lane
Arlington, OR 97812
(541) 454-2643
(541) 454-3279 Fax

PORT OF TACOMA
WAD001882984
3400 TAYLOR WAY
TACOMA WA 98421

CERTIFICATE OF DISPOSAL

Chemical Waste Management of the Northwest, Inc., ORD089452353, has received the following waste material:

GENERATOR:	PORT OF TACOMA
MANIFEST #:	010585396JJK
CWM TRACKING ID:	42716801
PROFILE #:	OR321468
LINE ITEM:	9b.1
QUANTITY:	1 D ⁷
RECEIVED DATE:	08/14/13
DISPOSAL PROCESS(ES):	LANDFILL
FINAL DISPOSAL LOCATION:	LANDFILL 13
DISPOSAL DATE:	08/14/13

I certify, on behalf of the above listed treatment facility, that to the best of my knowledge, the above-described waste material was managed in compliance with all applicable laws, regulations, permits and licenses on the date listed above.



CWMNW RECORDS DEPARTMENT
Date:

08/19/13



CHEMICAL WASTE MANAGEMENT OF THE NW

17629 Cedar Springs Lane
Arlington, OR 97812
(541) 454-2643
(541) 454-3279 Fax

PORT OF TACOMA
WAD001882984
3400 TAYLOR WAY
TACOMA WA 98421

CERTIFICATE OF DISPOSAL

Chemical Waste Management of the Northwest, Inc., ORD089452353, has received the following waste material:

GENERATOR:	PORT OF TACOMA
MANIFEST #:	010585397JJK
CWM TRACKING ID:	42715601
PROFILE #:	OR321468
LINE ITEM:	9b.1
QUANTITY:	1 DT
RECEIVED DATE:	08/14/13
DISPOSAL PROCESS(ES):	LANDFILL
FINAL DISPOSAL LOCATION:	LANDFILL 13
DISPOSAL DATE:	08/14/13

I certify, on behalf of the above listed treatment facility, that to the best of my knowledge, the above-described waste material was managed in compliance with all applicable laws, regulations, permits and licenses on the date listed above.



CWMNW RECORDS DEPARTMENT

Date: 08/19/13



CHEMICAL WASTE MANAGEMENT OF THE NW

17629 Cedar Springs Lane
Arlington, OR 97812
(541) 454-2643
(541) 454-3279 Fax

PORT OF TACOMA
WAD001882984
3400 TAYLOR WAY
TACOMA WA 98421

CERTIFICATE OF DISPOSAL

Chemical Waste Management of the Northwest, Inc., ORD089452353, has received the following waste material:

GENERATOR:	PORT OF TACOMA
MANIFEST #:	010585383JJK
CWM TRACKING ID:	42717201
PROFILE #:	OR321468
LINE ITEM:	9b.1
QUANTITY:	1 DT
RECEIVED DATE:	08/14/13
DISPOSAL PROCESS(ES):	LANDFILL
FINAL DISPOSAL LOCATION:	LANDFILL 13
DISPOSAL DATE:	08/14/13

I certify, on behalf of the above listed treatment facility, that to the best of my knowledge, the above-described waste material was managed in compliance with all applicable laws, regulations, permits and licenses on the date listed above.



CWMNW RECORDS DEPARTMENT
Date: 08/19/13



CHEMICAL WASTE MANAGEMENT OF THE NW

17629 Cedar Springs Lane
Arlington, OR 97812
(541) 454-2643
(541) 454-3279 Fax

PORT OF TACOMA
WAD001882984
3400 TAYLOR WAY
TACOMA WA 98421

CERTIFICATE OF DISPOSAL

Chemical Waste Management of the Northwest, Inc., ORD089452353, has received the following waste material:

GENERATOR:	PORT OF TACOMA
MANIFEST #:	010085266JJK
CWM TRACKING ID:	42722701
PROFILE #:	OR321468
LINE ITEM:	9b.1
QUANTITY:	1 DT
RECEIVED DATE:	08/15/13
DISPOSAL PROCESS(ES):	LANDFILL
FINAL DISPOSAL LOCATION:	LANDFILL 13
DISPOSAL DATE:	08/15/13

I certify, on behalf of the above listed treatment facility, that to the best of my knowledge, the above-described waste material was managed in compliance with all applicable laws, regulations, permits and licenses on the date listed above.

CWMNW RECORDS DEPARTMENT

Date: 08/19/13



CHEMICAL WASTE MANAGEMENT OF THE NW

17629 Cedar Springs Lane
Arlington, OR 97812
(541) 454-2643
(541) 454-3279 Fax

PORT OF TACOMA
WAD001882984
3400 TAYLOR WAY
TACOMA WA 98421

CERTIFICATE OF DISPOSAL

Chemical Waste Management of the Northwest, Inc., ORD089452353, has received the following waste material:

GENERATOR:	PORT OF TACOMA
MANIFEST #:	010585378JJK
CWM TRACKING ID:	42722201
PROFILE #:	OR321468
LINE ITEM:	9b.1
QUANTITY:	1 DT
RECEIVED DATE:	08/15/13
DISPOSAL PROCESS(ES):	LANDFILL
FINAL DISPOSAL LOCATION:	LANDFILL 13
DISPOSAL DATE:	08/15/13

I certify, on behalf of the above listed treatment facility, that to the best of my knowledge, the above-described waste material was managed in compliance with all applicable laws, regulations, permits and licenses on the date listed above.



CWMNW RECORDS DEPARTMENT

Date: 08/22/13



CHEMICAL WASTE MANAGEMENT OF THE NW

17629 Cedar Springs Lane
Arlington, OR 97812
(541) 454-2643
(541) 454-3279 Fax

PORT OF TACOMA
WAD001882984
3400 TAYLOR WAY
TACOMA WA 98421

CERTIFICATE OF DISPOSAL

Chemical Waste Management of the Northwest, Inc., ORD089452353, has received the following waste material:

GENERATOR: PORT OF TACOMA
MANIFEST #: 010585375JJK
CWM TRACKING ID: 42721101
PROFILE #: OR321468
LINE ITEM: 9b.1
QUANTITY: 1 DT
RECEIVED DATE: 08/15/13

DISPOSAL PROCESS(ES): LANDFILL
FINAL DISPOSAL LOCATION: LANDFILL 13
DISPOSAL DATE: 08/15/13

I certify, on behalf of the above listed treatment facility, that to the best of my knowledge, the above-described waste material was managed in compliance with all applicable laws, regulations, permits and licenses on the date listed above.

CWMNW RECORDS DEPARTMENT

Date: 08/19/13



CHEMICAL WASTE MANAGEMENT OF THE NW

17629 Cedar Springs Lane
Arlington, OR 97812
(541) 454-2643
(541) 454-3279 Fax

PORT OF TACOMA
WAD001882984
3400 TAYLOR WAY
TACOMA WA 98421

CERTIFICATE OF DISPOSAL

Chemical Waste Management of the Northwest, Inc., ORD089452353, has received the following waste material:

GENERATOR:	PORT OF TACOMA
MANIFEST #:	010585374JJK
CWM TRACKING ID:	42721201
PROFILE #:	OR321468
LINE ITEM:	9b.1
QUANTITY:	1 DT
RECEIVED DATE:	08/15/13
DISPOSAL PROCESS(ES):	LANDFILL
FINAL DISPOSAL LOCATION:	LANDFILL 13
DISPOSAL DATE:	08/15/13

I certify, on behalf of the above listed treatment facility, that to the best of my knowledge, the above-described waste material was managed in compliance with all applicable laws, regulations, permits and licenses on the date listed above.



CWMNW RECORDS DEPARTMENT

Date: 08/19/13



CHEMICAL WASTE MANAGEMENT OF THE NW

17629 Cedar Springs Lane
Arlington, OR 97812
(541) 454-2643
(541) 454-3279 Fax

PORT OF TACOMA
WAD001882984
3400 TAYLOR WAY
TACOMA WA 98421

CERTIFICATE OF DISPOSAL

Chemical Waste Management of the Northwest, Inc., ORD089452353, has received the following waste material:

GENERATOR:	PORT OF TACOMA
MANIFEST #:	010585373JJK
CWM TRACKING ID:	42721301
PROFILE #:	OR321468
LINE ITEM:	9b.1
QUANTITY:	1 DT
RECEIVED DATE:	08/15/13
DISPOSAL PROCESS(ES):	LANDFILL
FINAL DISPOSAL LOCATION:	LANDFILL 13
DISPOSAL DATE:	08/15/13

I certify, on behalf of the above listed treatment facility, that to the best of my knowledge, the above-described waste material was managed in compliance with all applicable laws, regulations, permits and licenses on the date listed above.

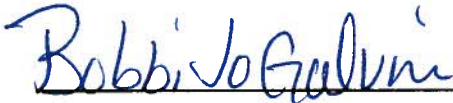

CWMNW RECORDS DEPARTMENT

Date: 08/19/13



CHEMICAL WASTE MANAGEMENT OF THE NW

17629 Cedar Springs Lane
Arlington, OR 97812
(541) 454-2643
(541) 454-3279 Fax

PORT OF TACOMA
WAD001882984
3400 TAYLOR WAY
TACOMA WA 98421

CERTIFICATE OF DISPOSAL

Chemical Waste Management of the Northwest, Inc., ORD089452353, has received the following waste material:

GENERATOR:	PORT OF TACOMA
MANIFEST #:	010585367JJK
CWM TRACKING ID:	42721401
PROFILE #:	OR321468
LINE ITEM:	9b.1
QUANTITY:	1 DT
RECEIVED DATE:	08/15/13
DISPOSAL PROCESS(ES):	LANDFILL
FINAL DISPOSAL LOCATION:	LANDFILL 13
DISPOSAL DATE:	08/15/13

I certify, on behalf of the above listed treatment facility, that to the best of my knowledge, the above-described waste material was managed in compliance with all applicable laws, regulations, permits and licenses on the date listed above.



CWMNW RECORDS DEPARTMENT

Date: 08/19/13



CHEMICAL WASTE MANAGEMENT OF THE NW

17629 Cedar Springs Lane
Arlington, OR 97812
(541) 454-2643
(541) 454-3279 Fax

PORT OF TACOMA
WAD001882984
3400 TAYLOR WAY
TACOMA WA 98421

CERTIFICATE OF DISPOSAL

Chemical Waste Management of the Northwest, Inc., ORD089452353, has received the following waste material:

GENERATOR:	PORT OF TACOMA
MANIFEST #:	010585372JJK
CWM TRACKING ID:	42721501
PROFILE #:	OR321468
LINE ITEM:	9b.1
QUANTITY:	1 DT
RECEIVED DATE:	08/15/13
DISPOSAL PROCESS(ES):	LANDFILL
FINAL DISPOSAL LOCATION:	LANDFILL 13
DISPOSAL DATE:	08/15/13

I certify, on behalf of the above listed treatment facility, that to the best of my knowledge, the above-described waste material was managed in compliance with all applicable laws, regulations, permits and licenses on the date listed above.

Bobbi Jo Galum

CWMNW RECORDS DEPARTMENT

Date: 08/19/13



CHEMICAL WASTE MANAGEMENT OF THE NW
17629 Cedar Springs Lane
Arlington, OR 97812
(541) 454-2643
(541) 454-3279 Fax

PORT OF TACOMA
WAD001882984
3400 TAYLOR WAY
TACOMA WA 98421

CERTIFICATE OF DISPOSAL

Chemical Waste Management of the Northwest, Inc., ORD089452353, has received the following waste material:

GENERATOR:	PORT OF TACOMA
MANIFEST #:	010585265JJK
CWM TRACKING ID:	42721601
PROFILE #:	OR321468
LINE ITEM:	9b.1
QUANTITY:	1 DT
RECEIVED DATE:	08/15/13
DISPOSAL PROCESS(ES):	LANDFILL
FINAL DISPOSAL LOCATION:	LANDFILL 13
DISPOSAL DATE:	08/15/13

I certify, on behalf of the above listed treatment facility, that to the best of my knowledge, the above-described waste material was managed in compliance with all applicable laws, regulations, permits and licenses on the date listed above.



CWMNW RECORDS DEPARTMENT

Date: 08/19/13



CHEMICAL WASTE MANAGEMENT OF THE NW
17629 Cedar Springs Lane
Arlington, OR 97812
(541) 454-2643
(541) 454-3279 Fax

PORT OF TACOMA
WAD001882984
3400 TAYLOR WAY
TACOMA WA 98421

CERTIFICATE OF DISPOSAL

Chemical Waste Management of the Northwest, Inc., ORD089452353, has received the following waste material:

GENERATOR:	PORT OF TACOMA
MANIFEST #:	010585389JJK
CWM TRACKING ID:	42721701
PROFILE #:	OR321468
LINE ITEM:	9b.1
QUANTITY:	1 DT
RECEIVED DATE:	08/15/13
DISPOSAL PROCESS(ES):	LANDFILL
FINAL DISPOSAL LOCATION:	LANDFILL 13
DISPOSAL DATE:	08/15/13

I certify, on behalf of the above listed treatment facility, that to the best of my knowledge, the above-described waste material was managed in compliance with all applicable laws, regulations, permits and licenses on the date listed above.



CWMNW RECORDS DEPARTMENT

Date: 08/19/13



CHEMICAL WASTE MANAGEMENT OF THE NW

17629 Cedar Springs Lane
Arlington, OR 97812
(541) 454-2643
(541) 454-3279 Fax

PORT OF TACOMA
WAD001882984
3400 TAYLOR WAY
TACOMA WA 98421

CERTIFICATE OF DISPOSAL

Chemical Waste Management of the Northwest, Inc., ORD089452353, has received the following waste material:

GENERATOR: PORT OF TACOMA
MANIFEST #: 010585379JJK
CWM TRACKING ID: 42721801
PROFILE #: OR321468
LINE ITEM: 9b.1
QUANTITY: 1 DT
RECEIVED DATE: 08/15/13

DISPOSAL PROCESS(ES): LANDFILL
FINAL DISPOSAL LOCATION: LANDFILL 13
DISPOSAL DATE: 08/15/13

I certify, on behalf of the above listed treatment facility, that to the best of my knowledge, the above-described waste material was managed in compliance with all applicable laws, regulations, permits and licenses on the date listed above.



CWMNW RECORDS DEPARTMENT

Date: 08/19/13



CHEMICAL WASTE MANAGEMENT OF THE NW

17629 Cedar Springs Lane
Arlington, OR 97812
(541) 454-2643
(541) 454-3279 Fax

PORT OF TACOMA
WAD001882984
3400 TAYLOR WAY
TACOMA WA 98421

CERTIFICATE OF DISPOSAL

Chemical Waste Management of the Northwest, Inc., ORD089452353, has received the following waste material:

GENERATOR: PORT OF TACOMA
MANIFEST #: 010585399JJK
CWM TRACKING ID: 42721901
PROFILE #: OR321468
LINE ITEM: 9b.1
QUANTITY: 1 DT
RECEIVED DATE: 08/15/13

DISPOSAL PROCESS(ES): LANDFILL
FINAL DISPOSAL LOCATION: LANDFILL 13
DISPOSAL DATE: 08/15/13

I certify, on behalf of the above listed treatment facility, that to the best of my knowledge, the above-described waste material was managed in compliance with all applicable laws, regulations, permits and licenses on the date listed above.



CWMNW RECORDS DEPARTMENT

Date: 08/19/13



CHEMICAL WASTE MANAGEMENT OF THE NW

17629 Cedar Springs Lane
Arlington, OR 97812
(541) 454-2643
(541) 454-3279 Fax

PORT OF TACOMA
WAD001882984
3400 TAYLOR WAY
TACOMA WA 98421

CERTIFICATE OF DISPOSAL

Chemical Waste Management of the Northwest, Inc., ORD089452353, has received the following waste material:

GENERATOR:	PORT OF TACOMA
MANIFEST #:	010585267JJK
CWM TRACKING ID:	4272201
PROFILE #:	OR321468
LINE ITEM:	9b.1
QUANTITY:	1 DT
RECEIVED DATE:	08/15/13
DISPOSAL PROCESS(ES):	LANDFILL
FINAL DISPOSAL LOCATION:	LANDFILL 13
DISPOSAL DATE:	08/15/13

I certify, on behalf of the above listed treatment facility, that to the best of my knowledge, the above-described waste material was managed in compliance with all applicable laws, regulations, permits and licenses on the date listed above.

CWMNW RECORDS DEPARTMENT

Date: 08/19/13



CHEMICAL WASTE MANAGEMENT OF THE NW

17629 Cedar Springs Lane
Arlington, OR 97812
(541) 454-2643
(541) 454-3279 Fax

PORT OF TACOMA
WAD001882984
3400 TAYLOR WAY
TACOMA WA 98421

CERTIFICATE OF DISPOSAL

Chemical Waste Management of the Northwest, Inc., ORD089452353, has received the following waste material:

GENERATOR: PORT OF TACOMA
MANIFEST #: 010585271JJK
CWM TRACKING ID: 42722301
PROFILE #: OR321468
LINE ITEM: 9b.1
QUANTITY: 1 DT
RECEIVED DATE: 08/15/13

DISPOSAL PROCESS(ES): LANDFILL
FINAL DISPOSAL LOCATION: LANDFILL 13
DISPOSAL DATE: 08/15/13

I certify, on behalf of the above listed treatment facility, that to the best of my knowledge, the above-described waste material was managed in compliance with all applicable laws, regulations, permits and licenses on the date listed above.



CWMNW RECORDS DEPARTMENT

Date: 08/19/13



CHEMICAL WASTE MANAGEMENT OF THE NW
17629 Cedar Springs Lane
Arlington, OR 97812
(541) 454-2643
(541) 454-3279 Fax

PORT OF TACOMA
WAD001882984
3400 TAYLOR WAY
TACOMA WA 98421

CERTIFICATE OF DISPOSAL

Chemical Waste Management of the Northwest, Inc., ORD089452353, has received the following waste material:

GENERATOR:	PORT OF TACOMA
MANIFEST #:	010585270JJK
CWM TRACKING ID:	42722401
PROFILE #:	OR321468
LINE ITEM:	9b.1
QUANTITY:	1 DT
RECEIVED DATE:	08/15/13
DISPOSAL PROCESS(ES):	LANDFILL
FINAL DISPOSAL LOCATION:	LANDFILL 13
DISPOSAL DATE:	08/15/13

I certify, on behalf of the above listed treatment facility, that to the best of my knowledge, the above-described waste material was managed in compliance with all applicable laws, regulations, permits and licenses on the date listed above.



CWMNW RECORDS DEPARTMENT

Date: 08/19/13



CHEMICAL WASTE MANAGEMENT OF THE NW

17629 Cedar Springs Lane
Arlington, OR 97812
(541) 454-2643
(541) 454-3279 Fax

PORT OF TACOMA
WAD001882984
3400 TAYLOR WAY
TACOMA WA 98421

CERTIFICATE OF DISPOSAL

Chemical Waste Management of the Northwest, Inc., ORD089452353, has received the following waste material:

GENERATOR:	PORT OF TACOMA
MANIFEST #:	010585376JJK
CWM TRACKING ID:	42719501
PROFILE #:	OR321468
LINE ITEM:	9b.1
QUANTITY:	1 DT
RECEIVED DATE:	08/15/13
DISPOSAL PROCESS(ES):	LANDFILL
FINAL DISPOSAL LOCATION:	LANDFILL 13
DISPOSAL DATE:	08/15/13

I certify, on behalf of the above listed treatment facility, that to the best of my knowledge, the above-described waste material was managed in compliance with all applicable laws, regulations, permits and licenses on the date listed above.

CWMNW RECORDS DEPARTMENT

Date: 08/19/13



CHEMICAL WASTE MANAGEMENT OF THE NW

17629 Cedar Springs Lane
Arlington, OR 97812
(541) 454-2643
(541) 454-3279 Fax

PORT OF TACOMA
WAD001882984
3400 TAYLOR WAY
TACOMA WA 98421

CERTIFICATE OF DISPOSAL

Chemical Waste Management of the Northwest, Inc., ORD089452353, has received the following waste material:

GENERATOR:	PORT OF TACOMA
MANIFEST #:	010585368JJK
CWM TRACKING ID:	42724701
PROFILE #:	OR321468
LINE ITEM:	9b.1
QUANTITY:	1 DT
RECEIVED DATE:	08/16/13
DISPOSAL PROCESS(ES):	LANDFILL
FINAL DISPOSAL LOCATION:	LANDFILL 13
DISPOSAL DATE:	08/16/13

I certify, on behalf of the above listed treatment facility, that to the best of my knowledge, the above-described waste material was managed in compliance with all applicable laws, regulations, permits and licenses on the date listed above.



CWMNW RECORDS DEPARTMENT

Date: 08/22/13



CHEMICAL WASTE MANAGEMENT OF THE NW

17629 Cedar Springs Lane
Arlington, OR 97812
(541) 454-2643
(541) 454-3279 Fax

PORT OF TACOMA
WAD001882984
3400 TAYLOR WAY
TACOMA WA 98421

CERTIFICATE OF DISPOSAL

Chemical Waste Management of the Northwest, Inc., ORD089452353, has received the following waste material:

GENERATOR:	PORT OF TACOMA
MANIFEST #:	010585371JJK
CWM TRACKING ID:	42724401
PROFILE #:	OR321468
LINE ITEM:	9b.1
QUANTITY:	1 DT
RECEIVED DATE:	08/16/13
DISPOSAL PROCESS(ES):	LANDFILL
FINAL DISPOSAL LOCATION:	LANDFILL 13
DISPOSAL DATE:	08/16/13

I certify, on behalf of the above listed treatment facility, that to the best of my knowledge, the above-described waste material was managed in compliance with all applicable laws, regulations, permits and licenses on the date listed above.



CWMNW RECORDS DEPARTMENT

Date: 08/22/13



CHEMICAL WASTE MANAGEMENT OF THE NW

17629 Cedar Springs Lane
Arlington, OR 97812
(541) 454-2643
(541) 454-3279 Fax

PORT OF TACOMA
WAD001882984
3400 TAYLOR WAY
TACOMA WA 98421

CERTIFICATE OF DISPOSAL

Chemical Waste Management of the Northwest, Inc., ORD089452353, has received the following waste material:

GENERATOR:	PORT OF TACOMA
MANIFEST #:	010585370JJK
CWM TRACKING ID:	42724501
PROFILE #:	OR321468
LINE ITEM:	9b.1
QUANTITY:	1 DT
RECEIVED DATE:	08/16/13
DISPOSAL PROCESS(ES):	LANDFILL
FINAL DISPOSAL LOCATION:	LANDFILL 13
DISPOSAL DATE:	08/16/13

I certify, on behalf of the above listed treatment facility, that to the best of my knowledge, the above-described waste material was managed in compliance with all applicable laws, regulations, permits and licenses on the date listed above.



CWMNW RECORDS DEPARTMENT
Date: 08/22/13



CHEMICAL WASTE MANAGEMENT OF THE NW

17629 Cedar Springs Lane
Arlington, OR 97812
(541) 454-2643
(541) 454-3279 Fax

PORT OF TACOMA
WAD001882984
3400 TAYLOR WAY
TACOMA WA 98421

CERTIFICATE OF DISPOSAL

Chemical Waste Management of the Northwest, Inc., ORD089452353, has received the following waste material:

GENERATOR:	PORT OF TACOMA
MANIFEST #:	010585369JJK
CWM TRACKING ID:	42724601
PROFILE #:	OR321468
LINE ITEM:	9b.1
QUANTITY:	1 DT
RECEIVED DATE:	08/16/13
DISPOSAL PROCESS(ES):	LANDFILL
FINAL DISPOSAL LOCATION:	LANDFILL 13
DISPOSAL DATE:	08/16/13

I certify, on behalf of the above listed treatment facility, that to the best of my knowledge, the above-described waste material was managed in compliance with all applicable laws, regulations, permits and licenses on the date listed above.



CWMNW RECORDS DEPARTMENT
Date:

08/22/13



CHEMICAL WASTE MANAGEMENT OF THE NW

17629 Cedar Springs Lane
Arlington, OR 97812
(541) 454-2643
(541) 454-3279 Fax

PORT OF TACOMA
WAD001882984
3400 TAYLOR WAY
TACOMA WA 98421

RECEIVED
SEP 23 2013
ENGINEERING DEPT.

CERTIFICATE OF DISPOSAL

Chemical Waste Management of the Northwest, Inc., ORD089452353, has received the following waste material:

GENERATOR:	PORT OF TACOMA
MANIFEST #:	010585272JJK
CWM TRACKING ID:	42724801
PROFILE #:	OR321468
LINE ITEM:	
QUANTITY:	1 DT
RECEIVED DATE:	08/16/13
DISPOSAL PROCESS(ES):	LANDFILL
FINAL DISPOSAL LOCATION:	LANDFILL 13
DISPOSAL DATE:	08/16/13

I certify, on behalf of the above listed treatment facility, that to the best of my knowledge, the above-described waste material was managed in compliance with all applicable laws, regulations, permits and licenses on the date listed above.



CWMNW RECORDS DEPARTMENT

Date: 08/22/13



CHEMICAL WASTE MANAGEMENT OF THE NW

17629 Cedar Springs Lane
Arlington, OR 97812
(541) 454-2643
(541) 454-3279 Fax

PORT OF TACOMA
WAD001882984
3400 TAYLOR WAY
TACOMA WA 98421

CERTIFICATE OF DISPOSAL

Chemical Waste Management of the Northwest, Inc., ORD089452353, has received the following waste material:

GENERATOR:	PORT OF TACOMA
MANIFEST #:	010585273JJK
CWM TRACKING ID:	42724901
PROFILE #:	OR321468
LINE ITEM:	
QUANTITY:	1 DT
RECEIVED DATE:	08/16/13
DISPOSAL PROCESS(ES):	LANDFILL
FINAL DISPOSAL LOCATION:	LANDFILL 13
DISPOSAL DATE:	08/16/13

I certify, on behalf of the above listed treatment facility, that to the best of my knowledge, the above-described waste material was managed in compliance with all applicable laws, regulations, permits and licenses on the date listed above.



CWMNW RECORDS DEPARTMENT

Date: 08/22/13



CHEMICAL WASTE MANAGEMENT OF THE NW

17629 Cedar Springs Lane
Arlington, OR 97812
(541) 454-2643
(541) 454-3279 Fax

PORT OF TACOMA
WAD001882984
3400 TAYLOR WAY
TACOMA WA 98421

CERTIFICATE OF DISPOSAL

Chemical Waste Management of the Northwest, Inc., ORD089452353, has received the following waste material:

GENERATOR:	PORT OF TACOMA
MANIFEST #:	010585277JJK
CWM TRACKING ID:	42725001
PROFILE #:	OR321468
LINE ITEM:	9b.1
QUANTITY:	1 DT
RECEIVED DATE:	08/16/13
DISPOSAL PROCESS(ES):	LANDFILL
FINAL DISPOSAL LOCATION:	LANDFILL 13
DISPOSAL DATE:	08/16/13

I certify, on behalf of the above listed treatment facility, that to the best of my knowledge, the above-described waste material was managed in compliance with all applicable laws, regulations, permits and licenses on the date listed above.



CWMNW RECORDS DEPARTMENT

Date: 08/22/13



CHEMICAL WASTE MANAGEMENT OF THE NW

17629 Cedar Springs Lane
Arlington, OR 97812
(541) 454-2643
(541) 454-3279 Fax

PORT OF TACOMA
WAD001882984
3400 TAYLOR WAY
TACOMA WA 98421

CERTIFICATE OF DISPOSAL

Chemical Waste Management of the Northwest, Inc., ORD089452353, has received the following waste material:

GENERATOR:	PORT OF TACOMA
MANIFEST #:	010585276JJK
CWM TRACKING ID:	42725101
PROFILE #:	OR321468
LINE ITEM:	9b.1
QUANTITY:	1 DT
RECEIVED DATE:	08/16/13
DISPOSAL PROCESS(ES):	LANDFILL
FINAL DISPOSAL LOCATION:	LANDFILL 13
DISPOSAL DATE:	08/13/13

I certify, on behalf of the above listed treatment facility, that to the best of my knowledge, the above-described waste material was managed in compliance with all applicable laws, regulations, permits and licenses on the date listed above.



CWMNW RECORDS DEPARTMENT

Date: 08/22/13



CHEMICAL WASTE MANAGEMENT OF THE NW

17629 Cedar Springs Lane
Arlington, OR 97812
(541) 454-2643
(541) 454-3279 Fax

PORT OF TACOMA
WAD001882984
3400 TAYLOR WAY
TACOMA WA 98421

CERTIFICATE OF DISPOSAL

Chemical Waste Management of the Northwest, Inc., ORD089452353, has received the following waste material:

GENERATOR:	PORT OF TACOMA
MANIFEST #:	010585278JJK
CWM TRACKING ID:	42725201
PROFILE #:	OR321468
LINE ITEM:	9b.1
QUANTITY:	1 DT
RECEIVED DATE:	08/16/13
DISPOSAL PROCESS(ES):	LANDFILL
FINAL DISPOSAL LOCATION:	LANDFILL 13
DISPOSAL DATE:	08/16/13

I certify, on behalf of the above listed treatment facility, that to the best of my knowledge, the above-described waste material was managed in compliance with all applicable laws, regulations, permits and licenses on the date listed above.



CWMNW RECORDS DEPARTMENT

Date: 08/22/13



CHEMICAL WASTE MANAGEMENT OF THE NW

17629 Cedar Springs Lane
Arlington, OR 97812
(541) 454-2643
(541) 454-3279 Fax

PORT OF TACOMA
WAD001882984
3400 TAYLOR WAY
TACOMA WA 98421

CERTIFICATE OF DISPOSAL

Chemical Waste Management of the Northwest, Inc., ORD089452353, has received the following waste material:

GENERATOR:	PORT OF TACOMA
MANIFEST #:	010585280JJK
CWM TRACKING ID:	42725301
PROFILE #:	OR321468
LINE ITEM:	9b.1
QUANTITY:	1 DT
RECEIVED DATE:	08/16/13
DISPOSAL PROCESS(ES):	LANDFILL
FINAL DISPOSAL LOCATION:	LANDFILL 13
DISPOSAL DATE:	08/16/13

I certify, on behalf of the above listed treatment facility, that to the best of my knowledge, the above-described waste material was managed in compliance with all applicable laws, regulations, permits and licenses on the date listed above.

CWMNW RECORDS DEPARTMENT

Date: 08/22/13



CHEMICAL WASTE MANAGEMENT OF THE NW

17629 Cedar Springs Lane
Arlington, OR 97812
(541) 454-2643
(541) 454-3279 Fax

PORT OF TACOMA
WAD001882984
3400 TAYLOR WAY
TACOMA WA 98421

CERTIFICATE OF DISPOSAL

Chemical Waste Management of the Northwest, Inc., ORD089452353, has received the following waste material:

GENERATOR:	PORT OF TACOMA
MANIFEST #:	010585279JJK
CWM TRACKING ID:	42725401
PROFILE #:	OR321468
LINE ITEM:	9b.1
QUANTITY:	1 DT
RECEIVED DATE:	08/16/13
DISPOSAL PROCESS(ES):	LANDFILL
FINAL DISPOSAL LOCATION:	LANDFILL 13
DISPOSAL DATE:	08/16/13

I certify, on behalf of the above listed treatment facility, that to the best of my knowledge, the above-described waste material was managed in compliance with all applicable laws, regulations, permits and licenses on the date listed above.



CWMNW RECORDS DEPARTMENT

Date: 08/22/13



CHEMICAL WASTE MANAGEMENT OF THE NW

17629 Cedar Springs Lane
Arlington, OR 97812
(541) 454-2643
(541) 454-3279 Fax

PORT OF TACOMA
WAD001882984
3400 TAYLOR WAY
TACOMA WA 98421

CERTIFICATE OF DISPOSAL

Chemical Waste Management of the Northwest, Inc., ORD089452353, has received the following waste material:

GENERATOR:	PORT OF TACOMA
MANIFEST #:	010585377JJK
CWM TRACKING ID:	42724301
PROFILE #:	OR321468
LINE ITEM:	9b.1
QUANTITY:	1 DT
RECEIVED DATE:	08/16/13
DISPOSAL PROCESS(ES):	LANDFILL
FINAL DISPOSAL LOCATION:	LANDFILL 13
DISPOSAL DATE:	08/13/13

I certify, on behalf of the above listed treatment facility, that to the best of my knowledge, the above-described waste material was managed in compliance with all applicable laws, regulations, permits and licenses on the date listed above.



CWMNW RECORDS DEPARTMENT
Date: 08/22/13



CHEMICAL WASTE MANAGEMENT OF THE NW

17629 Cedar Springs Lane
Arlington, OR 97812
(541) 454-2643
(541) 454-3279 Fax

PORT OF TACOMA
WAD001882984
3400 TAYLOR WAY
TACOMA WA 98421

CERTIFICATE OF DISPOSAL

Chemical Waste Management of the Northwest, Inc., ORD089452353, has received the following waste material:

GENERATOR:	PORT OF TACOMA
MANIFEST #:	010585269JJK
CWM TRACKING ID:	42724001
PROFILE #:	OR321468
LINE ITEM:	9b.1
QUANTITY:	1 DT
RECEIVED DATE:	08/16/13
DISPOSAL PROCESS(ES):	LANDFILL
FINAL DISPOSAL LOCATION:	LANDFILL 13
DISPOSAL DATE:	08/16/13

I certify, on behalf of the above listed treatment facility, that to the best of my knowledge, the above-described waste material was managed in compliance with all applicable laws, regulations, permits and licenses on the date listed above.

CWMNW RECORDS DEPARTMENT

Date: 08/22/13



CHEMICAL WASTE MANAGEMENT OF THE NW

17629 Cedar Springs Lane
Arlington, OR 97812
(541) 454-2643
(541) 454-3279 Fax

PORT OF TACOMA
WAD001882984
3400 TAYLOR WAY
TACOMA WA 98421

CERTIFICATE OF DISPOSAL

Chemical Waste Management of the Northwest, Inc., ORD089452353, has received the following waste material:

GENERATOR:	PORT OF TACOMA
MANIFEST #:	010585268JJK
CWM TRACKING ID:	42724101
PROFILE #:	OR321468
LINE ITEM:	9b.1
QUANTITY:	1 DT
RECEIVED DATE:	08/16/13
DISPOSAL PROCESS(ES):	LANDFILL
FINAL DISPOSAL LOCATION:	LANDFILL 13
DISPOSAL DATE:	08/16/13

I certify, on behalf of the above listed treatment facility, that to the best of my knowledge, the above-described waste material was managed in compliance with all applicable laws, regulations, permits and licenses on the date listed above.



CWMNW RECORDS DEPARTMENT

Date: 08/22/13



CHEMICAL WASTE MANAGEMENT OF THE NW

17629 Cedar Springs Lane
Arlington, OR 97812
(541) 454-2643
(541) 454-3279 Fax

PORT OF TACOMA
WAD001882984
3400 TAYLOR WAY
TACOMA WA 98421

CERTIFICATE OF DISPOSAL

Chemical Waste Management of the Northwest, Inc., ORD089452353, has received the following waste material:

GENERATOR:	PORT OF TACOMA
MANIFEST #:	010585282JJK
CWM TRACKING ID:	42727801
PROFILE #:	OR321468
LINE ITEM:	9b.1
QUANTITY:	1 DT
RECEIVED DATE:	08/19/13
DISPOSAL PROCESS(ES):	LANDFILL
FINAL DISPOSAL LOCATION:	LANDFILL 13
DISPOSAL DATE:	08/19/13

I certify, on behalf of the above listed treatment facility, that to the best of my knowledge, the above-described waste material was managed in compliance with all applicable laws, regulations, permits and licenses on the date listed above.



CWMNW RECORDS DEPARTMENT

Date: 08/22/13



CHEMICAL WASTE MANAGEMENT OF THE NW

17629 Cedar Springs Lane
Arlington, OR 97812
(541) 454-2643
(541) 454-3279 Fax

PORT OF TACOMA
WAD001882984
3400 TAYLOR WAY
TACOMA WA 98421

CERTIFICATE OF DISPOSAL

Chemical Waste Management of the Northwest, Inc., ORD089452353, has received the following waste material:

GENERATOR:	PORT OF TACOMA
MANIFEST #:	010585281JJK
CWM TRACKING ID:	42728001
PROFILE #:	OR321468
LINE ITEM:	9b.1
QUANTITY:	1 DT
RECEIVED DATE:	08/19/13
DISPOSAL PROCESS(ES):	LANDFILL
FINAL DISPOSAL LOCATION:	LANDFILL 13
DISPOSAL DATE:	08/19/13

I certify, on behalf of the above listed treatment facility, that to the best of my knowledge, the above-described waste material was managed in compliance with all applicable laws, regulations, permits and licenses on the date listed above.



CWMNW RECORDS DEPARTMENT

Date: 08/22/13



CHEMICAL WASTE MANAGEMENT OF THE NW

17629 Cedar Springs Lane
Arlington, OR 97812
(541) 454-2643
(541) 454-3279 Fax

PORT OF TACOMA
WAD001882984
3400 TAYLOR WAY
TACOMA WA 98421

CERTIFICATE OF DISPOSAL

Chemical Waste Management of the Northwest, Inc., ORD089452353, has received the following waste material:

GENERATOR:	PORT OF TACOMA
MANIFEST #:	010585283JJK
CWM TRACKING ID:	42728101
PROFILE #:	OR321468
LINE ITEM:	9b.1
QUANTITY:	1 DT
RECEIVED DATE:	08/19/13
DISPOSAL PROCESS(ES):	LANDFILL
FINAL DISPOSAL LOCATION:	LANDFILL 13
DISPOSAL DATE:	08/19/13

I certify, on behalf of the above listed treatment facility, that to the best of my knowledge, the above-described waste material was managed in compliance with all applicable laws, regulations, permits and licenses on the date listed above.

CWMNW RECORDS DEPARTMENT

Date: 08/22/13



CHEMICAL WASTE MANAGEMENT OF THE NW

17629 Cedar Springs Lane
Arlington, OR 97812
(541) 454-2643
(541) 454-3279 Fax

PORT OF TACOMA
WAD001882984
3400 TAYLOR WAY
TACOMA WA 98421

CERTIFICATE OF DISPOSAL

Chemical Waste Management of the Northwest, Inc., ORD089452353, has received the following waste material:

GENERATOR:	PORT OF TACOMA
MANIFEST #:	011880523JJK
CWM TRACKING ID:	42728301
PROFILE #:	OR321468
LINE ITEM:	9b.1
QUANTITY:	1 DT
RECEIVED DATE:	08/19/13
DISPOSAL PROCESS(ES):	LANDFILL
FINAL DISPOSAL LOCATION:	LANDFILL 13
DISPOSAL DATE:	08/19/13

I certify, on behalf of the above listed treatment facility, that to the best of my knowledge, the above-described waste material was managed in compliance with all applicable laws, regulations, permits and licenses on the date listed above.



CWMNW RECORDS DEPARTMENT

Date: 08/22/13



CHEMICAL WASTE MANAGEMENT OF THE NW

17629 Cedar Springs Lane
Arlington, OR 97812
(541) 454-2643
(541) 454-3279 Fax

PORT OF TACOMA
WAD001882984
3400 TAYLOR WAY
TACOMA WA 98421

CERTIFICATE OF DISPOSAL

Chemical Waste Management of the Northwest, Inc., ORD089452353, has received the following waste material:

GENERATOR:	PORT OF TACOMA
MANIFEST #:	011880522JJK
CWM TRACKING ID:	42728501
PROFILE #:	OR321468
LINE ITEM:	9b.1
QUANTITY:	1 DT
RECEIVED DATE:	08/19/13
DISPOSAL PROCESS(ES):	LANDFILL
FINAL DISPOSAL LOCATION:	LANDFILL 13
DISPOSAL DATE:	08/19/13

I certify, on behalf of the above listed treatment facility, that to the best of my knowledge, the above-described waste material was managed in compliance with all applicable laws, regulations, permits and licenses on the date listed above.



CWMNW RECORDS DEPARTMENT

Date: 08/22/13



CHEMICAL WASTE MANAGEMENT OF THE NW

17629 Cedar Springs Lane
Arlington, OR 97812
(541) 454-2643
(541) 454-3279 Fax

PORT OF TACOMA
WAD001882984
3400 TAYLOR WAY
TACOMA WA 98421

CERTIFICATE OF DISPOSAL

Chemical Waste Management of the Northwest, Inc., ORD089452353, has received the following waste material:

GENERATOR:	PORT OF TACOMA
MANIFEST #:	011180521JJK
CWM TRACKING ID:	42728601
PROFILE #:	OR321468
LINE ITEM:	9b.1
QUANTITY:	1 DT
RECEIVED DATE:	08/19/13
DISPOSAL PROCESS(ES):	LANDFILL
FINAL DISPOSAL LOCATION:	LANDFILL 13
DISPOSAL DATE:	08/19/13

I certify, on behalf of the above listed treatment facility, that to the best of my knowledge, the above-described waste material was managed in compliance with all applicable laws, regulations, permits and licenses on the date listed above.



CWMNW RECORDS DEPARTMENT

Date: 08/22/13



CHEMICAL WASTE MANAGEMENT OF THE NW

17629 Cedar Springs Lane
Arlington, OR 97812
(541) 454-2643
(541) 454-3279 Fax

PORT OF TACOMA
WAD001882984
3400 TAYLOR WAY
TACOMA WA 98421

CERTIFICATE OF DISPOSAL

Chemical Waste Management of the Northwest, Inc., ORD089452353, has received the following waste material:

GENERATOR:	PORT OF TACOMA
MANIFEST #:	011880524JJK
CWM TRACKING ID:	42728801
PROFILE #:	OR321468
LINE ITEM:	9b.1
QUANTITY:	1 DT
RECEIVED DATE:	08/19/13
DISPOSAL PROCESS(ES):	LANDFILL
FINAL DISPOSAL LOCATION:	LANDFILL 13
DISPOSAL DATE:	08/19/13

I certify, on behalf of the above listed treatment facility, that to the best of my knowledge, the above-described waste material was managed in compliance with all applicable laws, regulations, permits and licenses on the date listed above.



CWMNW RECORDS DEPARTMENT

Date: 08/22/13



CHEMICAL WASTE MANAGEMENT OF THE NW

17629 Cedar Springs Lane
Arlington, OR 97812
(541) 454-2643
(541) 454-3279 Fax

PORT OF TACOMA
WAD001882984
3400 TAYLOR WAY
TACOMA WA 98421

CERTIFICATE OF DISPOSAL

Chemical Waste Management of the Northwest, Inc., ORD089452353, has received the following waste material:

GENERATOR: PORT OF TACOMA
MANIFEST #: 010585274JJK
CWM TRACKING ID: 42725601
PROFILE #: OR321468
LINE ITEM: 9b.1
QUANTITY: 1 DT
RECEIVED DATE: 08/19/13

DISPOSAL PROCESS(ES): LANDFILL
FINAL DISPOSAL LOCATION: LANDFILL 13
DISPOSAL DATE: 08/19/13

I certify, on behalf of the above listed treatment facility, that to the best of my knowledge, the above-described waste material was managed in compliance with all applicable laws, regulations, permits and licenses on the date listed above.

CWMNW RECORDS DEPARTMENT

Date: 08/22/13



CHEMICAL WASTE MANAGEMENT OF THE NW

17629 Cedar Springs Lane
Arlington, OR 97812
(541) 454-2643
(541) 454-3279 Fax

PORT OF TACOMA
WAD001882984
3400 TAYLOR WAY
TACOMA WA 98421

CERTIFICATE OF DISPOSAL

Chemical Waste Management of the Northwest, Inc., ORD089452353, has received the following waste material:

GENERATOR:	PORT OF TACOMA
MANIFEST #:	011880504JJK
CWM TRACKING ID:	42725901
PROFILE #:	OR321468
LINE ITEM:	9b.1
QUANTITY:	1 DT
RECEIVED DATE:	08/19/13
DISPOSAL PROCESS(ES):	LANDFILL
FINAL DISPOSAL LOCATION:	LANDFILL 13
DISPOSAL DATE:	08/19/13

I certify, on behalf of the above listed treatment facility, that to the best of my knowledge, the above-described waste material was managed in compliance with all applicable laws, regulations, permits and licenses on the date listed above.



CWMNW RECORDS DEPARTMENT

Date: 08/22/13



CHEMICAL WASTE MANAGEMENT OF THE NW

17629 Cedar Springs Lane
Arlington, OR 97812
(541) 454-2643
(541) 454-3279 Fax

PORT OF TACOMA
WAD001882984
3400 TAYLOR WAY
TACOMA WA 98421

CERTIFICATE OF DISPOSAL

Chemical Waste Management of the Northwest, Inc., ORD089452353, has received the following waste material:

GENERATOR:	PORT OF TACOMA
MANIFEST #:	011880501JJK
CWM TRACKING ID:	42726001
PROFILE #:	OR321468
LINE ITEM:	9b.1
QUANTITY:	1 DT
RECEIVED DATE:	08/19/13
DISPOSAL PROCESS(ES):	LANDFILL
FINAL DISPOSAL LOCATION:	LANDFILL 13
DISPOSAL DATE:	08/13/13

I certify, on behalf of the above listed treatment facility, that to the best of my knowledge, the above-described waste material was managed in compliance with all applicable laws, regulations, permits and licenses on the date listed above.

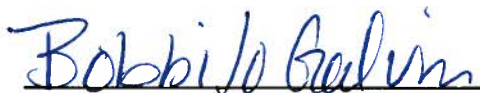

CWMNW RECORDS DEPARTMENT

Date: 08/22/13



CHEMICAL WASTE MANAGEMENT OF THE NW

17629 Cedar Springs Lane
Arlington, OR 97812
(541) 454-2643
(541) 454-3279 Fax

PORT OF TACOMA
WAD001882984
3400 TAYLOR WAY
TACOMA WA 98421

CERTIFICATE OF DISPOSAL

Chemical Waste Management of the Northwest, Inc., ORD089452353, has received the following waste material:

GENERATOR:	PORT OF TACOMA
MANIFEST #:	011880503JJK
CWM TRACKING ID:	42726101
PROFILE #:	OR321468
LINE ITEM:	9b.1
QUANTITY:	1 DT
RECEIVED DATE:	08/19/13
DISPOSAL PROCESS(ES):	LANDFILL
FINAL DISPOSAL LOCATION:	LANDFILL 13
DISPOSAL DATE:	08/19/13

I certify, on behalf of the above listed treatment facility, that to the best of my knowledge, the above-described waste material was managed in compliance with all applicable laws, regulations, permits and licenses on the date listed above.



CWMNW RECORDS DEPARTMENT

Date: 08/22/13



CHEMICAL WASTE MANAGEMENT OF THE NW

17629 Cedar Springs Lane
Arlington, OR 97812
(541) 454-2643
(541) 454-3279 Fax

PORT OF TACOMA
WAD001882984
3400 TAYLOR WAY
TACOMA WA 98421

CERTIFICATE OF DISPOSAL

Chemical Waste Management of the Northwest, Inc., ORD089452353, has received the following waste material:

GENERATOR:	PORT OF TACOMA
MANIFEST #:	011880506JJK
CWM TRACKING ID:	42726201
PROFILE #:	OR321468
LINE ITEM:	9b.1
QUANTITY:	1 DT
RECEIVED DATE:	08/19/13
DISPOSAL PROCESS(ES):	LANDFILL
FINAL DISPOSAL LOCATION:	LANDFILL 13
DISPOSAL DATE:	08/19/13

I certify, on behalf of the above listed treatment facility, that to the best of my knowledge, the above-described waste material was managed in compliance with all applicable laws, regulations, permits and licenses on the date listed above.



CWMNW RECORDS DEPARTMENT

Date: 08/22/13



CHEMICAL WASTE MANAGEMENT OF THE NW

17629 Cedar Springs Lane
Arlington, OR 97812
(541) 454-2643
(541) 454-3279 Fax

PORT OF TACOMA
WAD001882984
3400 TAYLOR WAY
TACOMA WA 98421

CERTIFICATE OF DISPOSAL

Chemical Waste Management of the Northwest, Inc., ORD089452353, has received the following waste material:

GENERATOR:	PORT OF TACOMA
MANIFEST #:	011880505JJK
CWM TRACKING ID:	42726301
PROFILE #:	OR321468
LINE ITEM:	9b.1
QUANTITY:	1 DT
RECEIVED DATE:	08/19/13
DISPOSAL PROCESS(ES):	LANDFILL
FINAL DISPOSAL LOCATION:	LANDFILL 13
DISPOSAL DATE:	08/19/13

I certify, on behalf of the above listed treatment facility, that to the best of my knowledge, the above-described waste material was managed in compliance with all applicable laws, regulations, permits and licenses on the date listed above.



CWMNW RECORDS DEPARTMENT

Date: 08/22/13



CHEMICAL WASTE MANAGEMENT OF THE NW

17629 Cedar Springs Lane
Arlington, OR 97812
(541) 454-2643
(541) 454-3279 Fax

PORT OF TACOMA
WAD001882984
3400 TAYLOR WAY
TACOMA WA 98421

CERTIFICATE OF DISPOSAL

Chemical Waste Management of the Northwest, Inc., ORD089452353, has received the following waste material:

GENERATOR:	PORT OF TACOMA
MANIFEST #:	011880507JJK
CWM TRACKING ID:	42726401
PROFILE #:	OR321468
LINE ITEM:	9b.1
QUANTITY:	1 DT
RECEIVED DATE:	08/19/13
DISPOSAL PROCESS(ES):	LANDFILL
FINAL DISPOSAL LOCATION:	LANDFILL 13
DISPOSAL DATE:	08/19/13

I certify, on behalf of the above listed treatment facility, that to the best of my knowledge, the above-described waste material was managed in compliance with all applicable laws, regulations, permits and licenses on the date listed above.



CWMNW RECORDS DEPARTMENT

Date: 08/22/13



CHEMICAL WASTE MANAGEMENT OF THE NW

17629 Cedar Springs Lane
Arlington, OR 97812
(541) 454-2643
(541) 454-3279 Fax

PORT OF TACOMA
WAD001882984
3400 TAYLOR WAY
TACOMA WA 98421

CERTIFICATE OF DISPOSAL

Chemical Waste Management of the Northwest, Inc., ORD089452353, has received the following waste material:

GENERATOR:	PORT OF TACOMA
MANIFEST #:	011880509JJK
CWM TRACKING ID:	42726501
PROFILE #:	OR321468
LINE ITEM:	9b.1
QUANTITY:	1 DT
RECEIVED DATE:	08/19/13
DISPOSAL PROCESS(ES):	LANDFILL
FINAL DISPOSAL LOCATION:	LANDFILL 13
DISPOSAL DATE:	08/19/13

I certify, on behalf of the above listed treatment facility, that to the best of my knowledge, the above-described waste material was managed in compliance with all applicable laws, regulations, permits and licenses on the date listed above.



CWMNW RECORDS DEPARTMENT

Date: 08/22/13



CHEMICAL WASTE MANAGEMENT OF THE NW

17629 Cedar Springs Lane
Arlington, OR 97812
(541) 454-2643
(541) 454-3279 Fax

PORT OF TACOMA
WAD001882984
3400 TAYLOR WAY
TACOMA WA 98421

CERTIFICATE OF DISPOSAL

Chemical Waste Management of the Northwest, Inc., ORD089452353, has received the following waste material:

GENERATOR:	PORT OF TACOMA
MANIFEST #:	010585285JJK
CWM TRACKING ID:	42726601
PROFILE #:	OR321468
LINE ITEM:	9b.1
QUANTITY:	1 DT
RECEIVED DATE:	08/19/13
DISPOSAL PROCESS(ES):	LANDFILL
FINAL DISPOSAL LOCATION:	LANDFILL 13
DISPOSAL DATE:	08/19/13

I certify, on behalf of the above listed treatment facility, that to the best of my knowledge, the above-described waste material was managed in compliance with all applicable laws, regulations, permits and licenses on the date listed above.



CWMNW RECORDS DEPARTMENT

Date: 08/22/13



CHEMICAL WASTE MANAGEMENT OF THE NW

17629 Cedar Springs Lane
Arlington, OR 97812
(541) 454-2643
(541) 454-3279 Fax

PORT OF TACOMA
WAD001882984
3400 TAYLOR WAY
TACOMA WA 98421

CERTIFICATE OF DISPOSAL

Chemical Waste Management of the Northwest, Inc., ORD089452353, has received the following waste material:

GENERATOR:	PORT OF TACOMA
MANIFEST #:	010585284JJK
CWM TRACKING ID:	42726701
PROFILE #:	OR321468
LINE ITEM:	9b.1
QUANTITY:	1 DT
RECEIVED DATE:	08/19/13
DISPOSAL PROCESS(ES):	LANDFILL
FINAL DISPOSAL LOCATION:	LANDFILL 13
DISPOSAL DATE:	08/19/13

I certify, on behalf of the above listed treatment facility, that to the best of my knowledge, the above-described waste material was managed in compliance with all applicable laws, regulations, permits and licenses on the date listed above.



CWMNW RECORDS DEPARTMENT
Date:

08/22/13



CHEMICAL WASTE MANAGEMENT OF THE NW

17629 Cedar Springs Lane
Arlington, OR 97812
(541) 454-2643
(541) 454-3279 Fax

PORT OF TACOMA
WAD001882984
3400 TAYLOR WAY
TACOMA WA 98421

CERTIFICATE OF DISPOSAL

Chemical Waste Management of the Northwest, Inc., ORD089452353, has received the following waste material:

GENERATOR:	PORT OF TACOMA
MANIFEST #:	011880508JJK
CWM TRACKING ID:	42726801
PROFILE #:	OR321468
LINE ITEM:	9b.1
QUANTITY:	1 DT
RECEIVED DATE:	08/19/13
DISPOSAL PROCESS(ES):	LANDFILL
FINAL DISPOSAL LOCATION:	LANDFILL 13
DISPOSAL DATE:	08/19/13

I certify, on behalf of the above listed treatment facility, that to the best of my knowledge, the above-described waste material was managed in compliance with all applicable laws, regulations, permits and licenses on the date listed above.



CWMNW RECORDS DEPARTMENT

Date: 08/22/13



CHEMICAL WASTE MANAGEMENT OF THE NW

17629 Cedar Springs Lane
Arlington, OR 97812
(541) 454-2643
(541) 454-3279 Fax

PORT OF TACOMA
WAD001882984
3400 TAYLOR WAY
TACOMA WA 98421

CERTIFICATE OF DISPOSAL

Chemical Waste Management of the Northwest, Inc., ORD089452353, has received the following waste material:

GENERATOR:	PORT OF TACOMA
MANIFEST #:	011880502JJK
CWM TRACKING ID:	42726901
PROFILE #:	OR321468
LINE ITEM:	9b.1
QUANTITY:	1 DT
RECEIVED DATE:	08/19/13
DISPOSAL PROCESS(ES):	LANDFILL
FINAL DISPOSAL LOCATION:	LANDFILL 13
DISPOSAL DATE:	08/19/13

I certify, on behalf of the above listed treatment facility, that to the best of my knowledge, the above-described waste material was managed in compliance with all applicable laws, regulations, permits and licenses on the date listed above.



CWMNW RECORDS DEPARTMENT

Date: 08/22/13



CHEMICAL WASTE MANAGEMENT OF THE NW

17629 Cedar Springs Lane
Arlington, OR 97812
(541) 454-2643
(541) 454-3279 Fax

PORT OF TACOMA
WAD001882984
3400 TAYLOR WAY
TACOMA WA 98421

CERTIFICATE OF DISPOSAL

Chemical Waste Management of the Northwest, Inc., ORD089452353, has received the following waste material:

GENERATOR:	PORT OF TACOMA
MANIFEST #:	011880510JJK
CWM TRACKING ID:	42730401
PROFILE #:	OR321468
LINE ITEM:	9b.1
QUANTITY:	1 DT
RECEIVED DATE:	08/20/13
DISPOSAL PROCESS(ES):	LANDFILL
FINAL DISPOSAL LOCATION:	LANDFILL 13
DISPOSAL DATE:	08/20/13

I certify, on behalf of the above listed treatment facility, that to the best of my knowledge, the above-described waste material was managed in compliance with all applicable laws, regulations, permits and licenses on the date listed above.



CWMNW RECORDS DEPARTMENT

Date: 08/28/13



CHEMICAL WASTE MANAGEMENT OF THE NW

17629 Cedar Springs Lane
Arlington, OR 97812
(541) 454-2643
(541) 454-3279 Fax

PORT OF TACOMA
WAD001882984
3400 TAYLOR WAY
TACOMA WA 98421

CERTIFICATE OF DISPOSAL

Chemical Waste Management of the Northwest, Inc., ORD089452353, has received the following waste material:

GENERATOR:	PORT OF TACOMA
MANIFEST #:	011880513JJK
CWM TRACKING ID:	42730501
PROFILE #:	OR321468
LINE ITEM:	9b.1
QUANTITY:	1 DT
RECEIVED DATE:	08/20/13
DISPOSAL PROCESS(ES):	LANDFILL
FINAL DISPOSAL LOCATION:	LANDFILL 13
DISPOSAL DATE:	08/20/13

I certify, on behalf of the above listed treatment facility, that to the best of my knowledge, the above-described waste material was managed in compliance with all applicable laws, regulations, permits and licenses on the date listed above.



CWMNW RECORDS DEPARTMENT

Date: 08/28/13



CHEMICAL WASTE MANAGEMENT OF THE NW

17629 Cedar Springs Lane
Arlington, OR 97812
(541) 454-2643
(541) 454-3279 Fax

PORT OF TACOMA
WAD001882984
3400 TAYLOR WAY
TACOMA WA 98421

CERTIFICATE OF DISPOSAL

Chemical Waste Management of the Northwest, Inc., ORD089452353, has received the following waste material:

GENERATOR:	PORT OF TACOMA
MANIFEST #:	011880514JJK
CWM TRACKING ID:	42730601
PROFILE #:	OR321468
LINE ITEM:	9b.1
QUANTITY:	1 DT
RECEIVED DATE:	08/20/13
DISPOSAL PROCESS(ES):	LANDFILL
FINAL DISPOSAL LOCATION:	LANDFILL 13
DISPOSAL DATE:	08/20/13

I certify, on behalf of the above listed treatment facility, that to the best of my knowledge, the above-described waste material was managed in compliance with all applicable laws, regulations, permits and licenses on the date listed above.



CWMNW RECORDS DEPARTMENT

Date: 08/28/13



CHEMICAL WASTE MANAGEMENT OF THE NW

17629 Cedar Springs Lane
Arlington, OR 97812
(541) 454-2643
(541) 454-3279 Fax

RECEIVED
SEP 23 2013
ENGINEERING DEPT.

PORT OF TACOMA
WAD001882984
3400 TAYLOR WAY
TACOMA WA 98421

CERTIFICATE OF DISPOSAL

Chemical Waste Management of the Northwest, Inc., ORD089452353, has received the following waste material:

GENERATOR:	PORT OF TACOMA
MANIFEST #:	011880526JJK
CWM TRACKING ID:	42730701
PROFILE #:	OR321468
LINE ITEM:	9b.1
QUANTITY:	1 DT
RECEIVED DATE:	08/20/13
DISPOSAL PROCESS(ES):	LANDFILL
FINAL DISPOSAL LOCATION:	LANDFILL 13
DISPOSAL DATE:	08/20/13

I certify, on behalf of the above listed treatment facility, that to the best of my knowledge, the above-described waste material was managed in compliance with all applicable laws, regulations, permits and licenses on the date listed above.

Robbi Galvin

CWMNW RECORDS DEPARTMENT

Date: 08/28/13



CHEMICAL WASTE MANAGEMENT OF THE NW

17629 Cedar Springs Lane
Arlington, OR 97812
(541) 454-2643
(541) 454-3279 Fax

PORT OF TACOMA
WAD001882984
3400 TAYLOR WAY
TACOMA WA 98421

CERTIFICATE OF DISPOSAL

Chemical Waste Management of the Northwest, Inc., ORD089452353, has received the following waste material:

GENERATOR:	PORT OF TACOMA
MANIFEST #:	010585275JJK
CWM TRACKING ID:	42731001
PROFILE #:	OR321468
LINE ITEM:	9b.1
QUANTITY:	1 DT
RECEIVED DATE:	08/20/13
DISPOSAL PROCESS(ES):	LANDFILL
FINAL DISPOSAL LOCATION:	LANDFILL 13
DISPOSAL DATE:	08/20/13

I certify, on behalf of the above listed treatment facility, that to the best of my knowledge, the above-described waste material was managed in compliance with all applicable laws, regulations, permits and licenses on the date listed above.

CWMNW RECORDS DEPARTMENT

Date: 08/28/13



CHEMICAL WASTE MANAGEMENT OF THE NW

17629 Cedar Springs Lane
Arlington, OR 97812
(541) 454-2643
(541) 454-3279 Fax

PORT OF TACOMA
WAD001882984
3400 TAYLOR WAY
TACOMA WA 98421

CERTIFICATE OF DISPOSAL

Chemical Waste Management of the Northwest, Inc., ORD089452353, has received the following waste material:

GENERATOR:	PORT OF TACOMA
MANIFEST #:	011880516JJK
CWM TRACKING ID:	42731101
PROFILE #:	OR321468
LINE ITEM:	9b.1
QUANTITY:	1 DT
RECEIVED DATE:	08/20/13
DISPOSAL PROCESS(ES):	LANDFILL
FINAL DISPOSAL LOCATION:	LANDFILL 13
DISPOSAL DATE:	08/20/13

I certify, on behalf of the above listed treatment facility, that to the best of my knowledge, the above-described waste material was managed in compliance with all applicable laws, regulations, permits and licenses on the date listed above.



CWMNW RECORDS DEPARTMENT

Date: 08/28/13



CHEMICAL WASTE MANAGEMENT OF THE NW

17629 Cedar Springs Lane
Arlington, OR 97812
(541) 454-2643
(541) 454-3279 Fax

PORT OF TACOMA
WAD001882984
3400 TAYLOR WAY
TACOMA WA 98421

CERTIFICATE OF DISPOSAL

Chemical Waste Management of the Northwest, Inc., ORD089452353, has received the following waste material:

GENERATOR:	PORT OF TACOMA
MANIFEST #:	011880515JJK
CWM TRACKING ID:	42731201
PROFILE #:	OR321468
LINE ITEM:	9b.1
QUANTITY:	1 DT
RECEIVED DATE:	08/20/13
DISPOSAL PROCESS(ES):	LANDFILL
FINAL DISPOSAL LOCATION:	LANDFILL 13
DISPOSAL DATE:	08/20/13

I certify, on behalf of the above listed treatment facility, that to the best of my knowledge, the above-described waste material was managed in compliance with all applicable laws, regulations, permits and licenses on the date listed above.



CWMNW RECORDS DEPARTMENT

Date: 08/28/13



CHEMICAL WASTE MANAGEMENT OF THE NW

17629 Cedar Springs Lane
Arlington, OR 97812
(541) 454-2643
(541) 454-3279 Fax

PORT OF TACOMA
WAD001882984
3400 TAYLOR WAY
TACOMA WA 98421

CERTIFICATE OF DISPOSAL

Chemical Waste Management of the Northwest, Inc., ORD089452353, has received the following waste material:

GENERATOR:	PORT OF TACOMA
MANIFEST #:	011880512JJK
CWM TRACKING ID:	42730301
PROFILE #:	OR321468
LINE ITEM:	9b.1
QUANTITY:	1 DT
RECEIVED DATE:	08/20/13
DISPOSAL PROCESS(ES):	LANDFILL
FINAL DISPOSAL LOCATION:	LANDFILL 13
DISPOSAL DATE:	08/20/13

I certify, on behalf of the above listed treatment facility, that to the best of my knowledge, the above-described waste material was managed in compliance with all applicable laws, regulations, permits and licenses on the date listed above.



CWMNW RECORDS DEPARTMENT

Date: 08/28/13



CHEMICAL WASTE MANAGEMENT OF THE NW

17629 Cedar Springs Lane
Arlington, OR 97812
(541) 454-2643
(541) 454-3279 Fax

PORT OF TACOMA
WAD001882984
3400 TAYLOR WAY
TACOMA WA 98421

CERTIFICATE OF DISPOSAL

Chemical Waste Management of the Northwest, Inc., ORD089452353, has received the following waste material:

GENERATOR:	PORT OF TACOMA
MANIFEST #:	011880511JJK
CWM TRACKING ID:	42730201
PROFILE #:	OR321468
LINE ITEM:	9b.1'
QUANTITY:	1 DT
RECEIVED DATE:	08/20/13
DISPOSAL PROCESS(ES):	LANDFILL
FINAL DISPOSAL LOCATION:	LANDFILL 13
DISPOSAL DATE:	08/20/13

I certify, on behalf of the above listed treatment facility, that to the best of my knowledge, the above-described waste material was managed in compliance with all applicable laws, regulations, permits and licenses on the date listed above.



CWMNW RECORDS DEPARTMENT

Date: 08/28/13



CHEMICAL WASTE MANAGEMENT OF THE NW

17629 Cedar Springs Lane
Arlington, OR 97812
(541) 454-2643
(541) 454-3279 Fax

PORT OF TACOMA
WAD001882984
3400 TAYLOR WAY
TACOMA WA 98421

CERTIFICATE OF DISPOSAL

Chemical Waste Management of the Northwest, Inc., ORD089452353, has received the following waste material:

GENERATOR:	PORT OF TACOMA
MANIFEST #:	011880525JJK
CWM TRACKING ID:	42729101
PROFILE #:	OR321468
LINE ITEM:	9b.1
QUANTITY:	1 DT
RECEIVED DATE:	08/20/13
DISPOSAL PROCESS(ES):	LANDFILL
FINAL DISPOSAL LOCATION:	LANDFILL 13
DISPOSAL DATE:	08/20/13

I certify, on behalf of the above listed treatment facility, that to the best of my knowledge, the above-described waste material was managed in compliance with all applicable laws, regulations, permits and licenses on the date listed above.



CWMNW RECORDS DEPARTMENT

Date: 08/28/13



CHEMICAL WASTE MANAGEMENT OF THE NW

17629 Cedar Springs Lane
Arlington, OR 97812
(541) 454-2643
(541) 454-3279 Fax

PORT OF TACOMA
WAD001882984
3400 TAYLOR WAY
TACOMA WA 99421

CERTIFICATE OF DISPOSAL

Chemical Waste Management of the Northwest, Inc., ORD089452353, has received the following waste material:

GENERATOR:	PORT OF TACOMA
MANIFEST #:	011880519JJK
CWM TRACKING ID:	42732201
PROFILE #:	OR321468
LINE ITEM:	9b.1
QUANTITY:	1 DT
RECEIVED DATE:	08/20/13
DISPOSAL PROCESS(ES):	LANDFILL
FINAL DISPOSAL LOCATION:	LANDFILL 13
DISPOSAL DATE:	08/20/13

I certify, on behalf of the above listed treatment facility, that to the best of my knowledge, the above-described waste material was managed in compliance with all applicable laws, regulations, permits and licenses on the date listed above.

Bobbi Jo Galvin

CWMNW RECORDS DEPARTMENT

Date: 08/28/13



CHEMICAL WASTE MANAGEMENT OF THE NW

17629 Cedar Springs Lane
Arlington, OR 97812
(541) 454-2643
(541) 454-3279 Fax

PORT OF TACOMA
WAD001882984
3400 TAYLOR WAY
TACOMA WA 99421

CERTIFICATE OF DISPOSAL

Chemical Waste Management of the Northwest, Inc., ORD089452353, has received the following waste material:

GENERATOR:	PORT OF TACOMA
MANIFEST #:	011880520JJK
CWM TRACKING ID:	42732101
PROFILE #:	OR321468
LINE ITEM:	9b.1
QUANTITY:	1 DT
RECEIVED DATE:	08/20/13
DISPOSAL PROCESS(ES):	LANDFILL
FINAL DISPOSAL LOCATION:	LANDFILL 13
DISPOSAL DATE:	08/20/13

I certify, on behalf of the above listed treatment facility, that to the best of my knowledge, the above-described waste material was managed in compliance with all applicable laws, regulations, permits and licenses on the date listed above.



CWMNW RECORDS DEPARTMENT

Date: 08/28/13



CHEMICAL WASTE MANAGEMENT OF THE NW

17629 Cedar Springs Lane
Arlington, OR 97812
(541) 454-2643
(541) 454-3279 Fax

PORT OF TACOMA
WAD001882984
3400 TAYLOR WAY
TACOMA WA 89421

CERTIFICATE OF DISPOSAL

Chemical Waste Management of the Northwest, Inc., ORD089452353, has received the following waste material:

GENERATOR:	PORT OF TACOMA
MANIFEST #:	011880529JJK
CWM TRACKING ID:	42732001
PROFILE #:	OR321468
LINE ITEM:	9b.1
QUANTITY:	1 DT
RECEIVED DATE:	08/20/13
DISPOSAL PROCESS(ES):	LANDFILL
FINAL DISPOSAL LOCATION:	LANDFILL 13
DISPOSAL DATE:	08/20/13

I certify, on behalf of the above listed treatment facility, that to the best of my knowledge, the above-described waste material was managed in compliance with all applicable laws, regulations, permits and licenses on the date listed above.

Robbie Graham

CWMNW RECORDS DEPARTMENT

Date: 08/28/13



CHEMICAL WASTE MANAGEMENT OF THE NW

17629 Cedar Springs Lane
Arlington, OR 97812
(541) 454-2643
(541) 454-3279 Fax

PORT OF TACOMA
WAD001882984
3400 TAYLOR WAY
TACOMA WA 98421

CERTIFICATE OF DISPOSAL

Chemical Waste Management of the Northwest, Inc., ORD089452353, has received the following waste material:

GENERATOR:	PORT OF TACOMA
MANIFEST #:	011880517JJK
CWM TRACKING ID:	42731501
PROFILE #:	OR321468
LINE ITEM:	9b.1
QUANTITY:	1 DT
RECEIVED DATE:	08/20/13
DISPOSAL PROCESS(ES):	LANDFILL
FINAL DISPOSAL LOCATION:	LANDFILL 13
DISPOSAL DATE:	08/20/13

I certify, on behalf of the above listed treatment facility, that to the best of my knowledge, the above-described waste material was managed in compliance with all applicable laws, regulations, permits and licenses on the date listed above.



CWMNW RECORDS DEPARTMENT

Date: 08/28/13



CHEMICAL WASTE MANAGEMENT OF THE NW

17629 Cedar Springs Lane
Arlington, OR 97812
(541) 454-2643
(541) 454-3279 Fax

PORT OF TACOMA
WAD001882984
3400 TAYLOR WAY
TACOMA WA 98421

CERTIFICATE OF DISPOSAL

Chemical Waste Management of the Northwest, Inc., ORD089452353, has received the following waste material:

GENERATOR:	PORT OF TACOMA
MANIFEST #:	011880518JJK
CWM TRACKING ID:	42731601
PROFILE #:	OR321468
LINE ITEM:	9b.1
QUANTITY:	1 DT
RECEIVED DATE:	08/20/13
DISPOSAL PROCESS(ES):	LANDFILL
FINAL DISPOSAL LOCATION:	LANDFILL 13
DISPOSAL DATE:	08/20/13

I certify, on behalf of the above listed treatment facility, that to the best of my knowledge, the above-described waste material was managed in compliance with all applicable laws, regulations, permits and licenses on the date listed above.

Bobbi Jo Galvin

CWMNW RECORDS DEPARTMENT

Date: 08/28/13



CHEMICAL WASTE MANAGEMENT OF THE NW

17629 Cedar Springs Lane
Arlington, OR 97812
(541) 454-2643
(541) 454-3279 Fax

PORT OF TACOMA
WAD001882984
3400 TAYLOR WAY
TACOMA WA 98421

CERTIFICATE OF DISPOSAL

Chemical Waste Management of the Northwest, Inc., ORD089452353, has received the following waste material:

GENERATOR:	PORT OF TACOMA
MANIFEST #:	011880530JJK
CWM TRACKING ID:	42731701
PROFILE #:	OR321468
LINE ITEM:	9b.1
QUANTITY:	1 DT
RECEIVED DATE:	08/20/13
DISPOSAL PROCESS(ES):	LANDFILL
FINAL DISPOSAL LOCATION:	LANDFILL 13
DISPOSAL DATE:	08/20/13

I certify, on behalf of the above listed treatment facility, that to the best of my knowledge, the above-described waste material was managed in compliance with all applicable laws, regulations, permits and licenses on the date listed above.



CWMNW RECORDS DEPARTMENT
Date: 08/28/13



CHEMICAL WASTE MANAGEMENT OF THE NW

17629 Cedar Springs Lane
Arlington, OR 97812
(541) 454-2643
(541) 454-3279 Fax

PORT OF TACOMA
WAD001882984
3400 TAYLOR WAY
TACOMA WA 98421

CERTIFICATE OF DISPOSAL

Chemical Waste Management of the Northwest, Inc., ORD089452353, has received the following waste material:

GENERATOR:	PORT OF TACOMA
MANIFEST #:	011880531JJK
CWM TRACKING ID:	42736901
PROFILE #:	OR321468
LINE ITEM:	9b.1
QUANTITY:	1 DT
RECEIVED DATE:	08/21/13
DISPOSAL PROCESS(ES):	LANDFILL
FINAL DISPOSAL LOCATION:	LANDFILL 13
DISPOSAL DATE:	08/21/13

I certify, on behalf of the above listed treatment facility, that to the best of my knowledge, the above-described waste material was managed in compliance with all applicable laws, regulations, permits and licenses on the date listed above.



CWMNW RECORDS DEPARTMENT

Date: 08/28/13



CHEMICAL WASTE MANAGEMENT OF THE NW

17629 Cedar Springs Lane
Arlington, OR 97812
(541) 454-2643
(541) 454-3279 Fax

PORT OF TACOMA
WAD001882984
3400 TAYLOR WAY
TACOMA WA 98421

CERTIFICATE OF DISPOSAL

Chemical Waste Management of the Northwest, Inc., ORD089452353, has received the following waste material:

GENERATOR:	PORT OF TACOMA
MANIFEST #:	011880536JJK
CWM TRACKING ID:	42736801
PROFILE #:	OR321468
LINE ITEM:	9b.1
QUANTITY:	1 DT
RECEIVED DATE:	08/21/13
DISPOSAL PROCESS(ES):	LANDFILL
FINAL DISPOSAL LOCATION:	LANDFILL 13
DISPOSAL DATE:	08/21/13

I certify, on behalf of the above listed treatment facility, that to the best of my knowledge, the above-described waste material was managed in compliance with all applicable laws, regulations, permits and licenses on the date listed above.

Robb J. Galvin

CWMNW RECORDS DEPARTMENT

Date: 08/28/13



CHEMICAL WASTE MANAGEMENT OF THE NORTHWEST

17629 Cedar Springs Lane
Arlington, OR 97812

PORT OF TACOMA
WAD001882984
3400 TAYLOR WAY
TACOMA WA 98421

CERTIFICATE OF DISPOSAL

Chemical Waste Management of the Northwest, Inc., ORD089452353, has received the following waste material:

GENERATOR:	PORT OF TACOMA
MANIFEST #:	011880535JJK
CWM TRACKING ID:	42736301
PROFILE #:	OR321468
LINE ITEM:	9b.1
QUANTITY:	1 DT
RECEIVED DATE:	08/21/13
DISPOSAL PROCESS(ES):	LANDFILL
FINAL DISPOSAL LOCATION:	LANDFILL 13
DISPOSAL DATE:	08/21/13

I certify, on behalf of the above listed treatment facility, that to the best of my knowledge, the above-described waste material was managed in compliance with all applicable laws, regulations, permits and licenses on the date listed above.

Bobbi Jo Galvin

CWMNW RECORDS DEPARTMENT

Date: 08/28/13



CHEMICAL WASTE MANAGEMENT OF THE NORTHWEST

17629 Cedar Springs Lane
Arlington, OR 97812

PORT OF TACOMA
WAD001882984
3400 TAYLOR WAY
TACOMA WA 98421

CERTIFICATE OF DISPOSAL

Chemical Waste Management of the Northwest, Inc., ORD089452353, has received the following waste material:

GENERATOR:	PORT OF TACOMA
MANIFEST #:	011880534JJK
CWM TRACKING ID:	42736201
PROFILE #:	OR321468
LINE ITEM:	9b.1
QUANTITY:	1 DT
RECEIVED DATE:	08/21/13
DISPOSAL PROCESS(ES):	LANDFILL
FINAL DISPOSAL LOCATION:	LANDFILL 13
DISPOSAL DATE:	08/21/13

I certify, on behalf of the above listed treatment facility, that to the best of my knowledge, the above-described waste material was managed in compliance with all applicable laws, regulations, permits and licenses on the date listed above.

Bobbi Jo Galvin

CWMNW RECORDS DEPARTMENT

Date: 08/28/13



CHEMICAL WASTE MANAGEMENT OF THE NW

17629 Cedar Springs Lane
Arlington, OR 97812
(541) 454-2643
(541) 454-3279 Fax

PORT OF TACOMA
WAD001882984
3400 TAYLOR WAY
TACOMA WA 98421

CERTIFICATE OF DISPOSAL

Chemical Waste Management of the Northwest, Inc., ORD089452353, has received the following waste material:

GENERATOR:	PORT OF TACOMA
MANIFEST #:	011880537JJK
CWM TRACKING ID:	42736101
PROFILE #:	OR321468
LINE ITEM:	9b.1
QUANTITY:	1 DT
RECEIVED DATE:	08/21/13
DISPOSAL PROCESS(ES):	LANDFILL
FINAL DISPOSAL LOCATION:	LANDFILL 13
DISPOSAL DATE:	08/21/13

I certify, on behalf of the above listed treatment facility, that to the best of my knowledge, the above-described waste material was managed in compliance with all applicable laws, regulations, permits and licenses on the date listed above.



CWMNW RECORDS DEPARTMENT

Date: 08/28/13



CHEMICAL WASTE MANAGEMENT OF THE NW

17629 Cedar Springs Lane
Arlington, OR 97812
(541) 454-2643
(541) 454-3279 Fax

PORT OF TACOMA
WAD001882984
3400 TAYLOR WAY
TACOMA WA 98421

CERTIFICATE OF DISPOSAL

Chemical Waste Management of the Northwest, Inc., ORD089452353, has received the following waste material:

GENERATOR:	PORT OF TACOMA
MANIFEST #:	011880546JJK
CWM TRACKING ID:	42735001
PROFILE #:	OR321468
LINE ITEM:	9b.1
QUANTITY:	1 DT
RECEIVED DATE:	08/21/13
DISPOSAL PROCESS(ES):	LANDFILL
FINAL DISPOSAL LOCATION:	LANDFILL 13
DISPOSAL DATE:	08/21/13

I certify, on behalf of the above listed treatment facility, that to the best of my knowledge, the above-described waste material was managed in compliance with all applicable laws, regulations, permits and licenses on the date listed above.



CWMNW RECORDS DEPARTMENT

Date: 08/28/13



CHEMICAL WASTE MANAGEMENT OF THE NW

17629 Cedar Springs Lane
Arlington, OR 97812
(541) 454-2643
(541) 454-3279 Fax

PORT OF TACOMA
WAD001882984
3400 TAYLOR WAY
TACOMA WA 98421

CERTIFICATE OF DISPOSAL

Chemical Waste Management of the Northwest, Inc., ORD089452353, has received the following waste material:

GENERATOR:	PORT OF TACOMA
MANIFEST #:	011880547JJK
CWM TRACKING ID:	42735101
PROFILE #:	OR321468
LINE ITEM:	9b.1
QUANTITY:	1 DT
RECEIVED DATE:	08/21/13
DISPOSAL PROCESS(ES):	LANDFILL
FINAL DISPOSAL LOCATION:	LANDFILL 13
DISPOSAL DATE:	08/21/13

I certify, on behalf of the above listed treatment facility, that to the best of my knowledge, the above-described waste material was managed in compliance with all applicable laws, regulations, permits and licenses on the date listed above.

Robin Jo Galvin

CWMNW RECORDS DEPARTMENT

Date: 08/28/13



CHEMICAL WASTE MANAGEMENT OF THE NW

17629 Cedar Springs Lane
Arlington, OR 97812
(541) 454-2643
(541) 454-3279 Fax

PORT OF TACOMA
WAD001882984
3400 TAYLOR WAY
TACOMA WA 98421

CERTIFICATE OF DISPOSAL

Chemical Waste Management of the Northwest, Inc., ORD089452353, has received the following waste material:

GENERATOR:	PORT OF TACOMA
MANIFEST #:	011880548JJK
CWM TRACKING ID:	42735301
PROFILE #:	OR321468
LINE ITEM:	9b.1
QUANTITY:	1 DT
RECEIVED DATE:	08/21/13
DISPOSAL PROCESS(ES):	LANDFILL
FINAL DISPOSAL LOCATION:	LANDFILL 13
DISPOSAL DATE:	08/21/13

I certify, on behalf of the above listed treatment facility, that to the best of my knowledge, the above-described waste material was managed in compliance with all applicable laws, regulations, permits and licenses on the date listed above.



CWMNW RECORDS DEPARTMENT

Date: 08/28/13



CHEMICAL WASTE MANAGEMENT OF THE NW

17629 Cedar Springs Lane
Arlington, OR 97812
(541) 454-2643
(541) 454-3279 Fax

PORT OF TACOMA
WAD001882984
3400 TAYLOR WAY
TACOMA WA 98421

CERTIFICATE OF DISPOSAL

Chemical Waste Management of the Northwest, Inc., ORD089452353, has received the following waste material:

GENERATOR:	PORT OF TACOMA
MANIFEST #:	011880541JJK
CWM TRACKING ID:	42735401
PROFILE #:	OR321468
LINE ITEM:	9b.1
QUANTITY:	1 DT
RECEIVED DATE:	08/21/13
DISPOSAL PROCESS(ES):	LANDFILL
FINAL DISPOSAL LOCATION:	LANDFILL 13
DISPOSAL DATE:	08/21/13

I certify, on behalf of the above listed treatment facility, that to the best of my knowledge, the above-described waste material was managed in compliance with all applicable laws, regulations, permits and licenses on the date listed above.

Bobbi Jo Galvin

CWMNW RECORDS DEPARTMENT

Date: 08/28/13



CHEMICAL WASTE MANAGEMENT OF THE NW

17629 Cedar Springs Lane
Arlington, OR 97812
(541) 454-2643
(541) 454-3279 Fax

PORT OF TACOMA
WAD001882984
3400 TAYLOR WAY
TACOMA WA 98421

CERTIFICATE OF DISPOSAL

Chemical Waste Management of the Northwest, Inc., ORD089452353, has received the following waste material:

GENERATOR:	PORT OF TACOMA
MANIFEST #:	011880538JJK
CWM TRACKING ID:	42735501
PROFILE #:	OR321468
LINE ITEM:	9b.1
QUANTITY:	1 DT
RECEIVED DATE:	08/21/13
DISPOSAL PROCESS(ES):	LANDFILL
FINAL DISPOSAL LOCATION:	LANDFILL 13
DISPOSAL DATE:	08/21/13

I certify, on behalf of the above listed treatment facility, that to the best of my knowledge, the above-described waste material was managed in compliance with all applicable laws, regulations, permits and licenses on the date listed above.

Bobbi Galvin

CWMNW RECORDS DEPARTMENT

Date: 08/28/13



CHEMICAL WASTE MANAGEMENT OF THE NW

17629 Cedar Springs Lane
Arlington, OR 97812
(541) 454-2643
(541) 454-3279 Fax

PORT OF TACOMA
WAD001882984
3400 TAYLOR WAY
TACOMA WA 98421

CERTIFICATE OF DISPOSAL

Chemical Waste Management of the Northwest, Inc., ORD089452353, has received the following waste material:

GENERATOR:	PORT OF TACOMA
MANIFEST #:	011880549JJK
CWM TRACKING ID:	42735601
PROFILE #:	OR321468
LINE ITEM:	9b.1
QUANTITY:	1 DT
RECEIVED DATE:	08/21/13
DISPOSAL PROCESS(ES):	LANDFILL
FINAL DISPOSAL LOCATION:	LANDFILL 13
DISPOSAL DATE:	08/21/13

I certify, on behalf of the above listed treatment facility, that to the best of my knowledge, the above-described waste material was managed in compliance with all applicable laws, regulations, permits and licenses on the date listed above.



CWMNW RECORDS DEPARTMENT

Date: 08/28/13



CHEMICAL WASTE MANAGEMENT OF THE NW

17629 Cedar Springs Lane
Arlington, OR 97812
(541) 454-2643
(541) 454-3279 Fax

PORT OF TACOMA
WAD001882984
3400 TAYLOR WAY
TACOMA WA 98421

CERTIFICATE OF DISPOSAL

Chemical Waste Management of the Northwest, Inc., ORD089452353, has received the following waste material:

GENERATOR:	PORT OF TACOMA
MANIFEST #:	011880528JJK
CWM TRACKING ID:	42735701
PROFILE #:	OR321468
LINE ITEM:	9b.1
QUANTITY:	1 DT
RECEIVED DATE:	08/21/13
DISPOSAL PROCESS(ES):	LANDFILL
FINAL DISPOSAL LOCATION:	LANDFILL 13
DISPOSAL DATE:	08/21/13

I certify, on behalf of the above listed treatment facility, that to the best of my knowledge, the above-described waste material was managed in compliance with all applicable laws, regulations, permits and licenses on the date listed above.



CWMNW RECORDS DEPARTMENT

Date: 08/28/13



CHEMICAL WASTE MANAGEMENT OF THE NW

17629 Cedar Springs Lane
Arlington, OR 97812
(541) 454-2643
(541) 454-3279 Fax

PORT OF TACOMA
WAD001882984
3400 TAYLOR WAY
TACOMA WA 98421

CERTIFICATE OF DISPOSAL

Chemical Waste Management of the Northwest, Inc., ORD089452353, has received the following waste material:

GENERATOR:	PORT OF TACOMA
MANIFEST #:	011880539JJK
CWM TRACKING ID:	42735801
PROFILE #:	OR321468
LINE ITEM:	9b.1
QUANTITY:	1 DT
RECEIVED DATE:	08/21/13
DISPOSAL PROCESS(ES):	LANDFILL
FINAL DISPOSAL LOCATION:	LANDFILL 13
DISPOSAL DATE:	08/21/13

I certify, on behalf of the above listed treatment facility, that to the best of my knowledge, the above-described waste material was managed in compliance with all applicable laws, regulations, permits and licenses on the date listed above.

CWMNW RECORDS DEPARTMENT

Date: 08/28/13



CHEMICAL WASTE MANAGEMENT OF THE NW

17629 Cedar Springs Lane
Arlington, OR 97812
(541) 454-2643
(541) 454-3279 Fax

PORT OF TACOMA
WAD001882984
3400 TAYLOR WAY
TACOMA WA 98421

CERTIFICATE OF DISPOSAL

Chemical Waste Management of the Northwest, Inc., ORD089452353, has received the following waste material:

GENERATOR:	PORT OF TACOMA
MANIFEST #:	011880542JJK
CWM TRACKING ID:	42735901
PROFILE #:	OR321468
LINE ITEM:	9b.1
QUANTITY:	1 DT
RECEIVED DATE:	08/21/13
DISPOSAL PROCESS(ES):	LANDFILL
FINAL DISPOSAL LOCATION:	LANDFILL 13
DISPOSAL DATE:	08/21/13

I certify, on behalf of the above listed treatment facility, that to the best of my knowledge, the above-described waste material was managed in compliance with all applicable laws, regulations, permits and licenses on the date listed above.

Robbi Jobalvin

CWMNW RECORDS DEPARTMENT

Date: 08/28/13



CHEMICAL WASTE MANAGEMENT OF THE NW

17629 Cedar Springs Lane
Arlington, OR 97812
(541) 454-2643
(541) 454-3279 Fax

PORT OF TACOMA
WAD001882984
3400 TAYLOR WAY
TACOMA WA 98421

CERTIFICATE OF DISPOSAL

Chemical Waste Management of the Northwest, Inc., ORD089452353, has received the following waste material:

GENERATOR:	PORT OF TACOMA
MANIFEST #:	011880555JJK
CWM TRACKING ID:	42734901
PROFILE #:	OR321468
LINE ITEM:	9b.1
QUANTITY:	1 DT
RECEIVED DATE:	08/21/13
DISPOSAL PROCESS(ES):	LANDFILL
FINAL DISPOSAL LOCATION:	LANDFILL 13
DISPOSAL DATE:	08/21/13

I certify, on behalf of the above listed treatment facility, that to the best of my knowledge, the above-described waste material was managed in compliance with all applicable laws, regulations, permits and licenses on the date listed above.



CWMNW RECORDS DEPARTMENT

Date: 08/28/13



CHEMICAL WASTE MANAGEMENT OF THE NW

17629 Cedar Springs Lane
Arlington, OR 97812
(541) 454-2643
(541) 454-3279 Fax

PORT OF TACOMA
WAD001882984
3400 TAYLOR WAY
TACOMA WA 98421

CERTIFICATE OF DISPOSAL

Chemical Waste Management of the Northwest, Inc., ORD089452353, has received the following waste material:

GENERATOR:	PORT OF TACOMA
MANIFEST #:	011880544JJK
CWM TRACKING ID:	42734801
PROFILE #:	OR321468
LINE ITEM:	9b.1
QUANTITY:	1 DT
RECEIVED DATE:	08/21/13
DISPOSAL PROCESS(ES):	LANDFILL
FINAL DISPOSAL LOCATION:	LANDFILL 13
DISPOSAL DATE:	08/21/13

I certify, on behalf of the above listed treatment facility, that to the best of my knowledge, the above-described waste material was managed in compliance with all applicable laws, regulations, permits and licenses on the date listed above.



CWMNW RECORDS DEPARTMENT

Date: 08/28/13



CHEMICAL WASTE MANAGEMENT OF THE NW

17629 Cedar Springs Lane
Arlington, OR 97812
(541) 454-2643
(541) 454-3279 Fax

PORT OF TACOMA
WAD001882984
3400 TAYLOR WAY
TACOMA WA 98421

CERTIFICATE OF DISPOSAL

Chemical Waste Management of the Northwest, Inc., ORD089452353, has received the following waste material:

GENERATOR:	PORT OF TACOMA
MANIFEST #:	011880545JJK
CWM TRACKING ID:	42734701
PROFILE #:	OR321468
LINE ITEM:	9b.1
QUANTITY:	1 DT
RECEIVED DATE:	08/21/13
DISPOSAL PROCESS(ES):	LANDFILL
FINAL DISPOSAL LOCATION:	LANDFILL 13
DISPOSAL DATE:	08/21/13

I certify, on behalf of the above listed treatment facility, that to the best of my knowledge, the above-described waste material was managed in compliance with all applicable laws, regulations, permits and licenses on the date listed above.



CWMNW RECORDS DEPARTMENT

Date: 08/28/13



CHEMICAL WASTE MANAGEMENT OF THE NW

17629 Cedar Springs Lane
Arlington, OR 97812
(541) 454-2643
(541) 454-3279 Fax

PORT OF TACOMA
WAD001882984
3400 TAYLOR WAY
TACOMA WA 98421

CERTIFICATE OF DISPOSAL

Chemical Waste Management of the Northwest, Inc., ORD089452353, has received the following waste material:

GENERATOR:	PORT OF TACOMA
MANIFEST #:	011880543JJK
CWM TRACKING ID:	42733101
PROFILE #:	OR321468
LINE ITEM:	9b.1
QUANTITY:	1 DT
RECEIVED DATE:	08/21/13
DISPOSAL PROCESS(ES):	LANDFILL
FINAL DISPOSAL LOCATION:	LANDFILL 13
DISPOSAL DATE:	08/21/13

I certify, on behalf of the above listed treatment facility, that to the best of my knowledge, the above-described waste material was managed in compliance with all applicable laws, regulations, permits and licenses on the date listed above.

Robbie Galvin

CWMNW RECORDS DEPARTMENT

Date: 08/28/13



CHEMICAL WASTE MANAGEMENT OF THE NW

17629 Cedar Springs Lane
Arlington, OR 97812
(541) 454-2643
(541) 454-3279 Fax

RECEIVED
SEP 23 2013
ENGINEERING DEPT.

PORT OF TACOMA
WAD001882984
3400 TAYLOR WAY
TACOMA WA 98421

CERTIFICATE OF DISPOSAL

Chemical Waste Management of the Northwest, Inc., ORD089452353, has received the following waste material:

GENERATOR:	PORT OF TACOMA
MANIFEST #:	011880577JJK
CWM TRACKING ID:	42740101
PROFILE #:	OR321468
LINE ITEM:	9b.1
QUANTITY:	1 DT
RECEIVED DATE:	08/22/13
DISPOSAL PROCESS(ES):	LANDFILL
FINAL DISPOSAL LOCATION:	LANDFILL 13
DISPOSAL DATE:	08/22/13

I certify, on behalf of the above listed treatment facility, that to the best of my knowledge, the above-described waste material was managed in compliance with all applicable laws, regulations, permits and licenses on the date listed above.

Robbi Jo Galvin

CWMNW RECORDS DEPARTMENT
Date: 08/29/13



CHEMICAL WASTE MANAGEMENT OF THE NW

17629 Cedar Springs Lane
Arlington, OR 97812
(541) 454-2643
(541) 454-3279 Fax

PORT OF TACOMA
WAD001882984
3400 TAYLOR WAY
TACOMA WA 98421

CERTIFICATE OF DISPOSAL

Chemical Waste Management of the Northwest, Inc., ORD089452353, has received the following waste material:

GENERATOR:	PORT OF TACOMA
MANIFEST #:	011880573JJK
CWM TRACKING ID:	42740001
PROFILE #:	OR321468
LINE ITEM:	9b.1
QUANTITY:	1 DT
RECEIVED DATE:	08/22/13
DISPOSAL PROCESS(ES):	LANDFILL
FINAL DISPOSAL LOCATION:	LANDFILL 13
DISPOSAL DATE:	08/22/13

I certify, on behalf of the above listed treatment facility, that to the best of my knowledge, the above-described waste material was managed in compliance with all applicable laws, regulations, permits and licenses on the date listed above.



CWMNW RECORDS DEPARTMENT

Date: 08/29/13



CHEMICAL WASTE MANAGEMENT OF THE NW

17629 Cedar Springs Lane
Arlington, OR 97812
(541) 454-2643
(541) 454-3279 Fax

PORT OF TACOMA
WAD001882984
3400 TAYLOR WAY
TACOMA WA 98421

CERTIFICATE OF DISPOSAL

Chemical Waste Management of the Northwest, Inc., ORD089452353, has received the following waste material:

GENERATOR:	PORT OF TACOMA
MANIFEST #:	011880574JJK
CWM TRACKING ID:	42739901
PROFILE #:	OR321468
LINE ITEM:	9b.1
QUANTITY:	1 DT ₄
RECEIVED DATE:	08/22/13
DISPOSAL PROCESS(ES):	LANDFILL
FINAL DISPOSAL LOCATION:	LANDFILL 13
DISPOSAL DATE:	08/22/13

I certify, on behalf of the above listed treatment facility, that to the best of my knowledge, the above-described waste material was managed in compliance with all applicable laws, regulations, permits and licenses on the date listed above.

Bobbi Jo Galvin

CWMNW RECORDS DEPARTMENT

Date: 08/29/13



CHEMICAL WASTE MANAGEMENT OF THE NW

17629 Cedar Springs Lane
Arlington, OR 97812
(541) 454-2643
(541) 454-3279 Fax

PORT OF TACOMA
WAD001882984
3400 TAYLOR WAY
TACOMA WA 98421

CERTIFICATE OF DISPOSAL

Chemical Waste Management of the Northwest, Inc., ORD089452353, has received the following waste material:

GENERATOR:	PORT OF TACOMA
MANIFEST #:	011880572JJK
CWM TRACKING ID:	42739801
PROFILE #:	OR321468
LINE ITEM:	9b.1
QUANTITY:	1 DT
RECEIVED DATE:	08/22/13
DISPOSAL PROCESS(ES):	LANDFILL
FINAL DISPOSAL LOCATION:	LANDFILL 13
DISPOSAL DATE:	08/22/13

I certify, on behalf of the above listed treatment facility, that to the best of my knowledge, the above-described waste material was managed in compliance with all applicable laws, regulations, permits and licenses on the date listed above.



CWMNW RECORDS DEPARTMENT

Date: 08/29/13



CHEMICAL WASTE MANAGEMENT OF THE NW

17629 Cedar Springs Lane
Arlington, OR 97812
(541) 454-2643
(541) 454-3279 Fax

PORT OF TACOMA
WAD001882984
3400 TAYLOR WAY
TACOMA WA 98421

CERTIFICATE OF DISPOSAL

Chemical Waste Management of the Northwest, Inc., ORD089452353, has received the following waste material:

GENERATOR:	PORT OF TACOMA
MANIFEST #:	011880576JJK
CWM TRACKING ID:	42739701
PROFILE #:	OR321468
LINE ITEM:	9b.1
QUANTITY:	1 DT
RECEIVED DATE:	08/22/13
DISPOSAL PROCESS(ES):	LANDFILL
FINAL DISPOSAL LOCATION:	LANDFILL 13
DISPOSAL DATE:	08/22/13

I certify, on behalf of the above listed treatment facility, that to the best of my knowledge, the above-described waste material was managed in compliance with all applicable laws, regulations, permits and licenses on the date listed above.

Bobbi Jo Galun

CWMNW RECORDS DEPARTMENT

Date: 08/29/13



CHEMICAL WASTE MANAGEMENT OF THE NW

17629 Cedar Springs Lane
Arlington, OR 97812
(541) 454-2643
(541) 454-3279 Fax

PORT OF TACOMA
WAD001882984
3400 TAYLOR WAY
TACOMA WA 98421

CERTIFICATE OF DISPOSAL

Chemical Waste Management of the Northwest, Inc., ORD089452353, has received the following waste material:

GENERATOR:	PORT OF TACOMA
MANIFEST #:	011880578JJK
CWM TRACKING ID:	42739601
PROFILE #:	OR321468
LINE ITEM:	9b.1
QUANTITY:	1 DT
RECEIVED DATE:	08/22/13
DISPOSAL PROCESS(ES):	LANDFILL
FINAL DISPOSAL LOCATION:	LANDFILL 13
DISPOSAL DATE:	08/22/13

I certify, on behalf of the above listed treatment facility, that to the best of my knowledge, the above-described waste material was managed in compliance with all applicable laws, regulations, permits and licenses on the date listed above.



CWMNW RECORDS DEPARTMENT

Date: 08/29/13



CHEMICAL WASTE MANAGEMENT OF THE NW

17629 Cedar Springs Lane
Arlington, OR 97812
(541) 454-2643
(541) 454-3279 Fax

PORT OF TACOMA
WAD001882984
3400 TAYLOR WAY
TACOMA WA 98421

CERTIFICATE OF DISPOSAL

Chemical Waste Management of the Northwest, Inc., ORD089452353, has received the following waste material:

GENERATOR:	PORT OF TACOMA
MANIFEST #:	011880580JJK
CWM TRACKING ID:	42739501
PROFILE #:	OR321468
LINE ITEM:	9b.1
QUANTITY:	1 DT
RECEIVED DATE:	08/22/13
DISPOSAL PROCESS(ES):	LANDFILL
FINAL DISPOSAL LOCATION:	LANDFILL 13
DISPOSAL DATE:	08/22/13

I certify, on behalf of the above listed treatment facility, that to the best of my knowledge, the above-described waste material was managed in compliance with all applicable laws, regulations, permits and licenses on the date listed above.

Bobbi Jo Galvin

CWMNW RECORDS DEPARTMENT

Date: 08/29/13



CHEMICAL WASTE MANAGEMENT OF THE NW

17629 Cedar Springs Lane
Arlington, OR 97812
(541) 454-2643
(541) 454-3279 Fax

PORT OF TACOMA
WAD001882984
3400 TAYLOR WAY
TACOMA WA 98421

CERTIFICATE OF DISPOSAL

Chemical Waste Management of the Northwest, Inc., ORD089452353, has received the following waste material:

GENERATOR:	PORT OF TACOMA
MANIFEST #:	011880582JJK
CWM TRACKING ID:	42739201
PROFILE #:	OR321468
LINE ITEM:	9b.1
QUANTITY:	1 DT
RECEIVED DATE:	08/22/13
DISPOSAL PROCESS(ES):	LANDFILL
FINAL DISPOSAL LOCATION:	LANDFILL 13
DISPOSAL DATE:	08/22/13

I certify, on behalf of the above listed treatment facility, that to the best of my knowledge, the above-described waste material was managed in compliance with all applicable laws, regulations, permits and licenses on the date listed above.



CWMNW RECORDS DEPARTMENT

Date: 08/29/13



CHEMICAL WASTE MANAGEMENT OF THE NW

17629 Cedar Springs Lane
Arlington, OR 97812
(541) 454-2643
(541) 454-3279 Fax

PORT OF TACOMA
WAD001882984
3400 TAYLOR WAY
TACOMA WA 98421

CERTIFICATE OF DISPOSAL

Chemical Waste Management of the Northwest, Inc., ORD089452353, has received the following waste material:

GENERATOR:	PORT OF TACOMA
MANIFEST #:	011880579JJK
CWM TRACKING ID:	42739401
PROFILE #:	OR321468
LINE ITEM:	9b.1
QUANTITY:	1 DT
RECEIVED DATE:	08/22/13
DISPOSAL PROCESS(ES):	LANDFILL
FINAL DISPOSAL LOCATION:	LANDFILL 13
DISPOSAL DATE:	08/22/13

I certify, on behalf of the above listed treatment facility, that to the best of my knowledge, the above-described waste material was managed in compliance with all applicable laws, regulations, permits and licenses on the date listed above.



CWMNW RECORDS DEPARTMENT

Date: 08/29/13



CHEMICAL WASTE MANAGEMENT OF THE NW

17629 Cedar Springs Lane
Arlington, OR 97812
(541) 454-2643
(541) 454-3279 Fax

PORT OF TACOMA
WAD001882984
3400 TAYLOR WAY
TACOMA WA 98421

CERTIFICATE OF DISPOSAL

Chemical Waste Management of the Northwest, Inc., ORD089452353, has received the following waste material:

GENERATOR:	PORT OF TACOMA
MANIFEST #:	011880583JJK
CWM TRACKING ID:	42738101
PROFILE #:	OR321468
LINE ITEM:	9b.1
QUANTITY:	1 DT
RECEIVED DATE:	08/22/13
DISPOSAL PROCESS(ES):	LANDFILL
FINAL DISPOSAL LOCATION:	LANDFILL 13
DISPOSAL DATE:	08/22/13

I certify, on behalf of the above listed treatment facility, that to the best of my knowledge, the above-described waste material was managed in compliance with all applicable laws, regulations, permits and licenses on the date listed above.



CWMNW RECORDS DEPARTMENT

Date: 08/29/13



CHEMICAL WASTE MANAGEMENT OF THE NW

17629 Cedar Springs Lane
Arlington, OR 97812
(541) 454-2643
(541) 454-3279 Fax

PORT OF TACOMA
WAD001882984
3400 TAYLOR WAY
TACOMA WA 98421

CERTIFICATE OF DISPOSAL

Chemical Waste Management of the Northwest, Inc., ORD089452353, has received the following waste material:

GENERATOR:	PORT OF TACOMA
MANIFEST #:	011880566JJK
CWM TRACKING ID:	42740401
PROFILE #:	OR321468
LINE ITEM:	9b.1
QUANTITY:	1 DT
RECEIVED DATE:	08/22/13
DISPOSAL PROCESS(ES):	LANDFILL
FINAL DISPOSAL LOCATION:	LANDFILL 13
DISPOSAL DATE:	08/22/13

I certify, on behalf of the above listed treatment facility, that to the best of my knowledge, the above-described waste material was managed in compliance with all applicable laws, regulations, permits and licenses on the date listed above.

Bobbi Galvin

CWMNW RECORDS DEPARTMENT

Date: 08/29/13



CHEMICAL WASTE MANAGEMENT OF THE NW

17629 Cedar Springs Lane
Arlington, OR 97812
(541) 454-2643
(541) 454-3279 Fax

PORT OF TACOMA
WAD001882984
3400 TAYLOR WAY
TACOMA WA 98421

CERTIFICATE OF DISPOSAL

Chemical Waste Management of the Northwest, Inc., ORD089452353, has received the following waste material:

GENERATOR:	PORT OF TACOMA
MANIFEST #:	011880569JJK
CWM TRACKING ID:	42740501
PROFILE #:	OR321468
LINE ITEM:	9b.1
QUANTITY:	1 DT
RECEIVED DATE:	08/22/13
DISPOSAL PROCESS(ES):	LANDFILL
FINAL DISPOSAL LOCATION:	LANDFILL 13
DISPOSAL DATE:	08/22/13

I certify, on behalf of the above listed treatment facility, that to the best of my knowledge, the above-described waste material was managed in compliance with all applicable laws, regulations, permits and licenses on the date listed above.



CWMNW RECORDS DEPARTMENT

Date: 08/29/13



CHEMICAL WASTE MANAGEMENT OF THE NW

17629 Cedar Springs Lane
Arlington, OR 97812
(541) 454-2643
(541) 454-3279 Fax

PORT OF TACOMA
WAD001882984
3400 TAYLOR WAY
TACOMA WA 98421

CERTIFICATE OF DISPOSAL

Chemical Waste Management of the Northwest, Inc., ORD089452353, has received the following waste material:

GENERATOR:	PORT OF TACOMA
MANIFEST #:	011880571JJK
CWM TRACKING ID:	42740601
PROFILE #:	OR321468
LINE ITEM:	9b.1
QUANTITY:	1 DT
RECEIVED DATE:	08/22/13
DISPOSAL PROCESS(ES):	LANDFILL
FINAL DISPOSAL LOCATION:	LANDFILL 13
DISPOSAL DATE:	08/22/13

I certify, on behalf of the above listed treatment facility, that to the best of my knowledge, the above-described waste material was managed in compliance with all applicable laws, regulations, permits and licenses on the date listed above.

Bobbi Jo Gavin

CWMNW RECORDS DEPARTMENT
Date:

08/29/13



CHEMICAL WASTE MANAGEMENT OF THE NW

17629 Cedar Springs Lane
Arlington, OR 97812
(541) 454-2643
(541) 454-3279 Fax

PORT OF TACOMA
WAD001882984
3400 TAYLOR WAY
TACOMA WA 98421

CERTIFICATE OF DISPOSAL

Chemical Waste Management of the Northwest, Inc., ORD089452353, has received the following waste material:

GENERATOR:	PORT OF TACOMA
MANIFEST #:	011880568JJK
CWM TRACKING ID:	42740901
PROFILE #:	OR321468
LINE ITEM:	9b.1
QUANTITY:	1 DT
RECEIVED DATE:	08/22/13
DISPOSAL PROCESS(ES):	LANDFILL
FINAL DISPOSAL LOCATION:	LANDFILL 13
DISPOSAL DATE:	08/22/13

I certify, on behalf of the above listed treatment facility, that to the best of my knowledge, the above-described waste material was managed in compliance with all applicable laws, regulations, permits and licenses on the date listed above.



CWMNW RECORDS DEPARTMENT

Date: 08/30/13



CHEMICAL WASTE MANAGEMENT OF THE NW

17629 Cedar Springs Lane
Arlington, OR 97812
(541) 454-2643
(541) 454-3279 Fax

PORT OF TACOMA
WAD001882984
3400 TAYLOR WAY
TACOMA WA 98421

CERTIFICATE OF DISPOSAL

Chemical Waste Management of the Northwest, Inc., ORD089452353, has received the following waste material:

GENERATOR:	PORT OF TACOMA
MANIFEST #:	011880567JJK
CWM TRACKING ID:	42741201
PROFILE #:	OR321468
LINE ITEM:	9b.1
QUANTITY:	1 DT
RECEIVED DATE:	08/22/13
DISPOSAL PROCESS(ES):	LANDFILL
FINAL DISPOSAL LOCATION:	LANDFILL 13
DISPOSAL DATE:	08/22/13

I certify, on behalf of the above listed treatment facility, that to the best of my knowledge, the above-described waste material was managed in compliance with all applicable laws, regulations, permits and licenses on the date listed above.

CWMNW RECORDS DEPARTMENT

Date: 08/30/13



CHEMICAL WASTE MANAGEMENT OF THE NW

17629 Cedar Springs Lane
Arlington, OR 97812
(541) 454-2643
(541) 454-3279 Fax

PORT OF TACOMA
WAD001882984
3400 TAYLOR WAY
TACOMA WA 98421

CERTIFICATE OF DISPOSAL

Chemical Waste Management of the Northwest, Inc., ORD089452353, has received the following waste material:

GENERATOR:	PORT OF TACOMA
MANIFEST #:	011880564JJK
CWM TRACKING ID:	42741301
PROFILE #:	OR321468
LINE ITEM:	9b.1
QUANTITY:	1 DT
RECEIVED DATE:	08/22/13
DISPOSAL PROCESS(ES):	LANDFILL
FINAL DISPOSAL LOCATION:	LANDFILL 13
DISPOSAL DATE:	08/22/13

I certify, on behalf of the above listed treatment facility, that to the best of my knowledge, the above-described waste material was managed in compliance with all applicable laws, regulations, permits and licenses on the date listed above.



CWMNW RECORDS DEPARTMENT

Date: 08/30/13



CHEMICAL WASTE MANAGEMENT OF THE NW

17629 Cedar Springs Lane
Arlington, OR 97812
(541) 454-2643
(541) 454-3279 Fax

PORT OF TACOMA
WAD001882984
3400 TAYLOR WAY
TACOMA WA 98421

CERTIFICATE OF DISPOSAL

Chemical Waste Management of the Northwest, Inc., ORD089452353, has received the following waste material:

GENERATOR:	PORT OF TACOMA
MANIFEST #:	011880565JJK
CWM TRACKING ID:	42741401
PROFILE #:	OR321468
LINE ITEM:	9b.1
QUANTITY:	1 DT
RECEIVED DATE:	08/22/13
DISPOSAL PROCESS(ES):	LANDFILL
FINAL DISPOSAL LOCATION:	LANDFILL 13
DISPOSAL DATE:	08/22/13

I certify, on behalf of the above listed treatment facility, that to the best of my knowledge, the above-described waste material was managed in compliance with all applicable laws, regulations, permits and licenses on the date listed above.



CWMNW RECORDS DEPARTMENT

Date: 08/30/13



CHEMICAL WASTE MANAGEMENT OF THE NW

17629 Cedar Springs Lane
Arlington, OR 97812
(541) 454-2643
(541) 454-3279 Fax

PORT OF TACOMA
WAD001882984
3400 TAYLOR WAY
TACOMA WA 98421

CERTIFICATE OF DISPOSAL

Chemical Waste Management of the Northwest, Inc., ORD089452353, has received the following waste material:

GENERATOR:	PORT OF TACOMA
MANIFEST #:	011880575JJK
CWM TRACKING ID:	42741501
PROFILE #:	OR321468
LINE ITEM:	9b.1
QUANTITY:	1 DT
RECEIVED DATE:	08/22/13
DISPOSAL PROCESS(ES):	LANDFILL
FINAL DISPOSAL LOCATION:	LANDFILL 13
DISPOSAL DATE:	08/22/13

I certify, on behalf of the above listed treatment facility, that to the best of my knowledge, the above-described waste material was managed in compliance with all applicable laws, regulations, permits and licenses on the date listed above.



CWMNW RECORDS DEPARTMENT

Date: 08/30/13



CHEMICAL WASTE MANAGEMENT OF THE NW

17629 Cedar Springs Lane
Arlington, OR 97812
(541) 454-2643
(541) 454-3279 Fax

PORT OF TACOMA
WAD001882984
3400 TAYLOR WAY
TACOMA WA 98421

CERTIFICATE OF DISPOSAL

Chemical Waste Management of the Northwest, Inc., ORD089452353, has received the following waste material:

GENERATOR:	PORT OF TACOMA
MANIFEST #:	011880563JJK
CWM TRACKING ID:	42742301
PROFILE #:	OR321468
LINE ITEM:	9b.1
QUANTITY:	1 DT
RECEIVED DATE:	08/22/13
DISPOSAL PROCESS(ES):	LANDFILL
FINAL DISPOSAL LOCATION:	LANDFILL 13
DISPOSAL DATE:	08/22/13

I certify, on behalf of the above listed treatment facility, that to the best of my knowledge, the above-described waste material was managed in compliance with all applicable laws, regulations, permits and licenses on the date listed above.



CWMNW RECORDS DEPARTMENT

Date: 08/30/13



CHEMICAL WASTE MANAGEMENT OF THE NW

17629 Cedar Springs Lane
Arlington, OR 97812
(541) 454-2643
(541) 454-3279 Fax

PORT OF TACOMA
WAD001882984
3400 TAYLOR WAY
TACOMA WA 98421

CERTIFICATE OF DISPOSAL

Chemical Waste Management of the Northwest, Inc., ORD089452353, has received the following waste material:

GENERATOR:	PORT OF TACOMA
MANIFEST #:	011880570JJK
CWM TRACKING ID:	42740701
PROFILE #:	OR321468
LINE ITEM:	9b.1
QUANTITY:	1 DT
RECEIVED DATE:	08/22/13
DISPOSAL PROCESS(ES):	LANDFILL
FINAL DISPOSAL LOCATION:	LANDFILL 13
DISPOSAL DATE:	08/22/13

I certify, on behalf of the above listed treatment facility, that to the best of my knowledge, the above-described waste material was managed in compliance with all applicable laws, regulations, permits and licenses on the date listed above.



CWMNW RECORDS DEPARTMENT

Date: 08/30/13



CHEMICAL WASTE MANAGEMENT OF THE NW

17629 Cedar Springs Lane
Arlington, OR 97812
(541) 454-2643
(541) 454-3279 Fax

PORT OF TACOMA
WAD001882984
3400 TAYLOR WAY
TACOMA WA 98421

CERTIFICATE OF DISPOSAL

Chemical Waste Management of the Northwest, Inc., ORD089452353, has received the following waste material:

GENERATOR:	PORT OF TACOMA
MANIFEST #:	011880581JJK
CWM TRACKING ID:	42739301
PROFILE #:	OR321468
LINE ITEM:	9b.1
QUANTITY:	1 DT
RECEIVED DATE:	08/22/13
DISPOSAL PROCESS(ES):	LANDFILL
FINAL DISPOSAL LOCATION:	LANDFILL 13
DISPOSAL DATE:	08/22/13

I certify, on behalf of the above listed treatment facility, that to the best of my knowledge, the above-described waste material was managed in compliance with all applicable laws, regulations, permits and licenses on the date listed above.



CWMNW RECORDS DEPARTMENT
Date: 08/30/13



CHEMICAL WASTE MANAGEMENT OF THE NW

17629 Cedar Springs Lane
Arlington, OR 97812
(541) 454-2643
(541) 454-3279 Fax

PORT OF TACOMA
WAD001882984
3400 TAYLOR WAY
TACOMA WA 98421

CERTIFICATE OF DISPOSAL

Chemical Waste Management of the Northwest, Inc., ORD089452353, has received the following waste material:

GENERATOR:	PORT OF TACOMA
MANIFEST #:	011880588JJK
CWM TRACKING ID:	42743501
PROFILE #:	OR321468
LINE ITEM:	9b.1
QUANTITY:	1 DT
RECEIVED DATE:	08/23/13
DISPOSAL PROCESS(ES):	LANDFILL
FINAL DISPOSAL LOCATION:	LANDFILL 13
DISPOSAL DATE:	08/23/13

I certify, on behalf of the above listed treatment facility, that to the best of my knowledge, the above-described waste material was managed in compliance with all applicable laws, regulations, permits and licenses on the date listed above.

Bobbin Galvin

CWMNW RECORDS DEPARTMENT

Date: 08/30/13



CHEMICAL WASTE MANAGEMENT OF THE NW

17629 Cedar Springs Lane
Arlington, OR 97812
(541) 454-2643
(541) 454-3279 Fax

PORT OF TACOMA
WAD001882984
3400 TAYLOR WAY
TACOMA WA 98421

CERTIFICATE OF DISPOSAL

Chemical Waste Management of the Northwest, Inc., ORD089452353, has received the following waste material:

GENERATOR:	PORT OF TACOMA
MANIFEST #:	011880592JJK
CWM TRACKING ID:	42743701
PROFILE #:	OR321468
LINE ITEM:	9b.1
QUANTITY:	1 DT
RECEIVED DATE:	08/23/13
DISPOSAL PROCESS(ES):	LANDFILL
FINAL DISPOSAL LOCATION:	LANDFILL 13
DISPOSAL DATE:	08/23/13

I certify, on behalf of the above listed treatment facility, that to the best of my knowledge, the above-described waste material was managed in compliance with all applicable laws, regulations, permits and licenses on the date listed above.



CWMNW RECORDS DEPARTMENT

Date: 08/30/13



CHEMICAL WASTE MANAGEMENT OF THE NW

17629 Cedar Springs Lane
Arlington, OR 97812
(541) 454-2643
(541) 454-3279 Fax

PORT OF TACOMA
WAD001882984
3400 TAYLOR WAY
TACOMA WA 98421

CERTIFICATE OF DISPOSAL

Chemical Waste Management of the Northwest, Inc., ORD089452353, has received the following waste material:

GENERATOR:	PORT OF TACOMA
MANIFEST #:	011880589JJK
CWM TRACKING ID:	42743801
PROFILE #:	OR321468
LINE ITEM:	9b.1
QUANTITY:	1 DT
RECEIVED DATE:	08/23/13
DISPOSAL PROCESS(ES):	LANDFILL
FINAL DISPOSAL LOCATION:	LANDFILL 13
DISPOSAL DATE:	08/23/13

I certify, on behalf of the above listed treatment facility, that to the best of my knowledge, the above-described waste material was managed in compliance with all applicable laws, regulations, permits and licenses on the date listed above.



CWMNW RECORDS DEPARTMENT

Date: 08/30/13



CHEMICAL WASTE MANAGEMENT OF THE NW

17629 Cedar Springs Lane
Arlington, OR 97812
(541) 454-2643
(541) 454-3279 Fax

PORT OF TACOMA
WAD001882984
3400 TAYLOR WAY
TACOMA WA 98421

CERTIFICATE OF DISPOSAL

Chemical Waste Management of the Northwest, Inc., ORD089452353, has received the following waste material:

GENERATOR:	PORT OF TACOMA
MANIFEST #:	011880587JJK
CWM TRACKING ID:	42743901
PROFILE #:	OR321468
LINE ITEM:	9b.1
QUANTITY:	1 DT
RECEIVED DATE:	08/23/13
DISPOSAL PROCESS(ES):	LANDFILL
FINAL DISPOSAL LOCATION:	LANDFILL 13
DISPOSAL DATE:	08/23/13

I certify, on behalf of the above listed treatment facility, that to the best of my knowledge, the above-described waste material was managed in compliance with all applicable laws, regulations, permits and licenses on the date listed above.



CWMNW RECORDS DEPARTMENT

Date: 08/30/13



CHEMICAL WASTE MANAGEMENT OF THE NW

17629 Cedar Springs Lane
Arlington, OR 97812
(541) 454-2643
(541) 454-3279 Fax

PORT OF TACOMA
WAD001882984
3400 TAYLOR WAY
TACOMA WA 98421

CERTIFICATE OF DISPOSAL

Chemical Waste Management of the Northwest, Inc., ORD089452353, has received the following waste material:

GENERATOR:	PORT OF TACOMA
MANIFEST #:	011880596JJK
CWM TRACKING ID:	42744001
PROFILE #:	OR321468
LINE ITEM:	9b.1
QUANTITY:	1 DT
RECEIVED DATE:	08/23/13
DISPOSAL PROCESS(ES):	LANDFILL
FINAL DISPOSAL LOCATION:	LANDFILL 13
DISPOSAL DATE:	08/23/13

I certify, on behalf of the above listed treatment facility, that to the best of my knowledge, the above-described waste material was managed in compliance with all applicable laws, regulations, permits and licenses on the date listed above.



CWMNW RECORDS DEPARTMENT

Date: 08/30/13



CHEMICAL WASTE MANAGEMENT OF THE NW

17629 Cedar Springs Lane
Arlington, OR 97812
(541) 454-2643
(541) 454-3279 Fax

PORT OF TACOMA
WAD001882984
3400 TAYLOR WAY
TACOMA WA 98421

CERTIFICATE OF DISPOSAL

Chemical Waste Management of the Northwest, Inc., ORD089452353, has received the following waste material:

GENERATOR:	PORT OF TACOMA
MANIFEST #:	011880602JJK
CWM TRACKING ID:	42744101
PROFILE #:	OR321468
LINE ITEM:	9b.1
QUANTITY:	1 DT
RECEIVED DATE:	08/23/13
DISPOSAL PROCESS(ES):	LANDFILL
FINAL DISPOSAL LOCATION:	LANDFILL 13
DISPOSAL DATE:	08/23/13

I certify, on behalf of the above listed treatment facility, that to the best of my knowledge, the above-described waste material was managed in compliance with all applicable laws, regulations, permits and licenses on the date listed above.

Bobbi Jo Graham

CWMNW RECORDS DEPARTMENT

Date: 08/30/13



CHEMICAL WASTE MANAGEMENT OF THE NW

17629 Cedar Springs Lane
Arlington, OR 97812
(541) 454-2643
(541) 454-3279 Fax

PORT OF TACOMA
WAD001882984
3400 TAYLOR WAY
TACOMA WA 98421

CERTIFICATE OF DISPOSAL

Chemical Waste Management of the Northwest, Inc., ORD089452353, has received the following waste material:

GENERATOR:	PORT OF TACOMA
MANIFEST #:	011880609JJK
CWM TRACKING ID:	42744201
PROFILE #:	OR321468
LINE ITEM:	9b.1
QUANTITY:	1 DT
RECEIVED DATE:	08/23/13
DISPOSAL PROCESS(ES):	LANDFILL
FINAL DISPOSAL LOCATION:	LANDFILL 13
DISPOSAL DATE:	08/23/13

I certify, on behalf of the above listed treatment facility, that to the best of my knowledge, the above-described waste material was managed in compliance with all applicable laws, regulations, permits and licenses on the date listed above.

Bobbi J. Galvin

CWMNW RECORDS DEPARTMENT

Date: 08/30/13



CHEMICAL WASTE MANAGEMENT OF THE NW

17629 Cedar Springs Lane
Arlington, OR 97812
(541) 454-2643
(541) 454-3279 Fax

PORT OF TACOMA
WAD001882984
3400 TAYLOR WAY
TACOMA WA 98421

CERTIFICATE OF DISPOSAL

Chemical Waste Management of the Northwest, Inc., ORD089452353, has received the following waste material:

GENERATOR:	PORT OF TACOMA
MANIFEST #:	011880594JJK
CWM TRACKING ID:	42744301
PROFILE #:	OR321468
LINE ITEM:	9b.1
QUANTITY:	1 DT
RECEIVED DATE:	08/23/13
DISPOSAL PROCESS(ES):	LANDFILL
FINAL DISPOSAL LOCATION:	LANDFILL 13
DISPOSAL DATE:	08/23/13

I certify, on behalf of the above listed treatment facility, that to the best of my knowledge, the above-described waste material was managed in compliance with all applicable laws, regulations, permits and licenses on the date listed above.



CWMNW RECORDS DEPARTMENT

Date: 08/30/13



CHEMICAL WASTE MANAGEMENT OF THE NW

17629 Cedar Springs Lane
Arlington, OR 97812
(541) 454-2643
(541) 454-3279 Fax

PORT OF TACOMA
WAD001882984
3400 TAYLOR WAY
TACOMA WA 98421

CERTIFICATE OF DISPOSAL

Chemical Waste Management of the Northwest, Inc., ORD089452353, has received the following waste material:

GENERATOR:	PORT OF TACOMA
MANIFEST #:	011880603JJK
CWM TRACKING ID:	42744401
PROFILE #:	OR321468
LINE ITEM:	9b.1
QUANTITY:	1 DT
RECEIVED DATE:	08/23/13
DISPOSAL PROCESS(ES):	LANDFILL
FINAL DISPOSAL LOCATION:	LANDFILL 13
DISPOSAL DATE:	08/23/13

I certify, on behalf of the above listed treatment facility, that to the best of my knowledge, the above-described waste material was managed in compliance with all applicable laws, regulations, permits and licenses on the date listed above.



CWMNW RECORDS DEPARTMENT

Date: 08/30/13



CHEMICAL WASTE MANAGEMENT OF THE NW

17629 Cedar Springs Lane
Arlington, OR 97812
(541) 454-2643
(541) 454-3279 Fax

PORT OF TACOMA
WAD001882984
3400 TAYLOR WAY
TACOMA WA 98421

CERTIFICATE OF DISPOSAL

Chemical Waste Management of the Northwest, Inc., ORD089452353, has received the following waste material:

GENERATOR:	PORT OF TACOMA
MANIFEST #:	011880598JJK
CWM TRACKING ID:	42744501
PROFILE #:	OR321468
LINE ITEM:	9b.1
QUANTITY:	1 DT
RECEIVED DATE:	08/23/13
DISPOSAL PROCESS(ES):	LANDFILL
FINAL DISPOSAL LOCATION:	LANDFILL 13
DISPOSAL DATE:	08/23/13

I certify, on behalf of the above listed treatment facility, that to the best of my knowledge, the above-described waste material was managed in compliance with all applicable laws, regulations, permits and licenses on the date listed above.



CWMNW RECORDS DEPARTMENT
Date:

08/30/13



CHEMICAL WASTE MANAGEMENT OF THE NW

17629 Cedar Springs Lane
Arlington, OR 97812
(541) 454-2643
(541) 454-3279 Fax

PORT OF TACOMA
WAD001882984
3400 TAYLOR WAY
TACOMA WA 98421

CERTIFICATE OF DISPOSAL

Chemical Waste Management of the Northwest, Inc., ORD089452353, has received the following waste material:

GENERATOR:	PORT OF TACOMA
MANIFEST #:	011880608JJK
CWM TRACKING ID:	42744601
PROFILE #:	OR321468
LINE ITEM:	9b.1
QUANTITY:	1 DT
RECEIVED DATE:	08/23/13
DISPOSAL PROCESS(ES):	LANDFILL
FINAL DISPOSAL LOCATION:	LANDFILL 13
DISPOSAL DATE:	08/23/13

I certify, on behalf of the above listed treatment facility, that to the best of my knowledge, the above-described waste material was managed in compliance with all applicable laws, regulations, permits and licenses on the date listed above.



CWMNW RECORDS DEPARTMENT
Date:

08/30/13



CHEMICAL WASTE MANAGEMENT OF THE NW

17629 Cedar Springs Lane
Arlington, OR 97812
(541) 454-2643
(541) 454-3279 Fax

PORT OF TACOMA
WAD001882984
3400 TAYLOR WAY
TACOMA WA 98421

CERTIFICATE OF DISPOSAL

Chemical Waste Management of the Northwest, Inc., ORD089452353, has received the following waste material:

GENERATOR:	PORT OF TACOMA
MANIFEST #:	011880606JJK
CWM TRACKING ID:	42744701
PROFILE #:	OR321468
LINE ITEM:	9b.1
QUANTITY:	1 DT
RECEIVED DATE:	08/23/13
DISPOSAL PROCESS(ES):	LANDFILL
FINAL DISPOSAL LOCATION:	LANDFILL 13
DISPOSAL DATE:	08/23/13

I certify, on behalf of the above listed treatment facility, that to the best of my knowledge, the above-described waste material was managed in compliance with all applicable laws, regulations, permits and licenses on the date listed above.



CWMNW RECORDS DEPARTMENT

Date: 08/30/13



CHEMICAL WASTE MANAGEMENT OF THE NW

17629 Cedar Springs Lane
Arlington, OR 97812
(541) 454-2643
(541) 454-3279 Fax

PORT OF TACOMA
WAD001882984
3400 TAYLOR WAY
TACOMA WA 98421

CERTIFICATE OF DISPOSAL

Chemical Waste Management of the Northwest, Inc., ORD089452353, has received the following waste material:

GENERATOR:	PORT OF TACOMA
MANIFEST #:	011880605JJK
CWM TRACKING ID:	42744801
PROFILE #:	OR321468
LINE ITEM:	9b.1
QUANTITY:	1 DT
RECEIVED DATE:	08/23/13
DISPOSAL PROCESS(ES):	LANDFILL
FINAL DISPOSAL LOCATION:	LANDFILL 13
DISPOSAL DATE:	08/23/13

I certify, on behalf of the above listed treatment facility, that to the best of my knowledge, the above-described waste material was managed in compliance with all applicable laws, regulations, permits and licenses on the date listed above.



CWMNW RECORDS DEPARTMENT

Date: 08/30/13



CHEMICAL WASTE MANAGEMENT OF THE NW

17629 Cedar Springs Lane
Arlington, OR 97812
(541) 454-2643
(541) 454-3279 Fax

PORT OF TACOMA
WAD001882984
3400 TAYLOR WAY
TACOMA WA 98421

CERTIFICATE OF DISPOSAL

Chemical Waste Management of the Northwest, Inc., ORD089452353, has received the following waste material:

GENERATOR:	PORT OF TACOMA
MANIFEST #:	011880600JJK
CWM TRACKING ID:	42744901
PROFILE #:	OR321468
LINE ITEM:	9b.1
QUANTITY:	1 DT
RECEIVED DATE:	08/23/13
DISPOSAL PROCESS(ES):	LANDFILL
FINAL DISPOSAL LOCATION:	LANDFILL 13
DISPOSAL DATE:	08/23/13

I certify, on behalf of the above listed treatment facility, that to the best of my knowledge, the above-described waste material was managed in compliance with all applicable laws, regulations, permits and licenses on the date listed above.



CWMNW RECORDS DEPARTMENT

Date: 08/30/13



CHEMICAL WASTE MANAGEMENT OF THE NW

17629 Cedar Springs Lane
Arlington, OR 97812
(541) 454-2643
(541) 454-3279 Fax

PORT OF TACOMA
WAD001882984
3400 TAYLOR WAY
TACOMA WA 98421

CERTIFICATE OF DISPOSAL

Chemical Waste Management of the Northwest, Inc., ORD089452353, has received the following waste material:

GENERATOR:	PORT OF TACOMA
MANIFEST #:	011880607JJK
CWM TRACKING ID:	42745001
PROFILE #:	OR321468
LINE ITEM:	9b.1
QUANTITY:	1 DT
RECEIVED DATE:	08/23/13
DISPOSAL PROCESS(ES):	LANDFILL
FINAL DISPOSAL LOCATION:	LANDFILL 13
DISPOSAL DATE:	08/23/13

I certify, on behalf of the above listed treatment facility, that to the best of my knowledge, the above-described waste material was managed in compliance with all applicable laws, regulations, permits and licenses on the date listed above.

CWMNW RECORDS DEPARTMENT

Date: 08/30/13



CHEMICAL WASTE MANAGEMENT OF THE NW

17629 Cedar Springs Lane
Arlington, OR 97812
(541) 454-2643
(541) 454-3279 Fax

PORT OF TACOMA
WAD001882984
3400 TAYLOR WAY
TACOMA WA 98421

CERTIFICATE OF DISPOSAL

Chemical Waste Management of the Northwest, Inc., ORD089452353, has received the following waste material:

GENERATOR:	PORT OF TACOMA
MANIFEST #:	011880604JJK
CWM TRACKING ID:	42745101
PROFILE #:	OR321468
LINE ITEM:	9b.1
QUANTITY:	1 DT
RECEIVED DATE:	08/23/13
DISPOSAL PROCESS(ES):	LANDFILL
FINAL DISPOSAL LOCATION:	LANDFILL 13
DISPOSAL DATE:	08/23/13

I certify, on behalf of the above listed treatment facility, that to the best of my knowledge, the above-described waste material was managed in compliance with all applicable laws, regulations, permits and licenses on the date listed above.

Robin Galvin

CWMNW RECORDS DEPARTMENT

Date: 08/30/13



CHEMICAL WASTE MANAGEMENT OF THE NW

17629 Cedar Springs Lane
Arlington, OR 97812
(541) 454-2643
(541) 454-3279 Fax

PORT OF TACOMA
WAD001882984
3400 TAYLOR WAY
TACOMA WA 98421

CERTIFICATE OF DISPOSAL

Chemical Waste Management of the Northwest, Inc., ORD089452353, has received the following waste material:

GENERATOR:	PORT OF TACOMA
MANIFEST #:	011880601JJK
CWM TRACKING ID:	42745201
PROFILE #:	OR321468
LINE ITEM:	9b.1
QUANTITY:	1 DT
RECEIVED DATE:	08/23/13
DISPOSAL PROCESS(ES):	LANDFILL
FINAL DISPOSAL LOCATION:	LANDFILL 13
DISPOSAL DATE:	08/23/13

I certify, on behalf of the above listed treatment facility, that to the best of my knowledge, the above-described waste material was managed in compliance with all applicable laws, regulations, permits and licenses on the date listed above.

Robbin Galvin

CWMNW RECORDS DEPARTMENT

Date: 08/30/13



CHEMICAL WASTE MANAGEMENT OF THE NW

17629 Cedar Springs Lane
Arlington, OR 97812
(541) 454-2643
(541) 454-3279 Fax

PORT OF TACOMA
WAD001882984
3400 TAYLOR WAY
TACOMA WA 98421

CERTIFICATE OF DISPOSAL

Chemical Waste Management of the Northwest, Inc., ORD089452353, has received the following waste material:

GENERATOR:	PORT OF TACOMA
MANIFEST #:	011880595JJK
CWM TRACKING ID:	42745301
PROFILE #:	OR321468
LINE ITEM:	9b.1
QUANTITY:	1 DT
RECEIVED DATE:	08/23/13
DISPOSAL PROCESS(ES):	LANDFILL
FINAL DISPOSAL LOCATION:	LANDFILL 13
DISPOSAL DATE:	08/23/13

I certify, on behalf of the above listed treatment facility, that to the best of my knowledge, the above-described waste material was managed in compliance with all applicable laws, regulations, permits and licenses on the date listed above.

Bobbie Jo Galvin

CWMNW RECORDS DEPARTMENT

Date: 08/30/13



CHEMICAL WASTE MANAGEMENT OF THE NW

17629 Cedar Springs Lane
Arlington, OR 97812
(541) 454-2643
(541) 454-3279 Fax

PORT OF TACOMA
WAD001882984
3400 TAYLOR WAY
TACOMA WA 98421

CERTIFICATE OF DISPOSAL

Chemical Waste Management of the Northwest, Inc., ORD089452353, has received the following waste material:

GENERATOR:	PORT OF TACOMA
MANIFEST #:	011880597JJK
CWM TRACKING ID:	42745401
PROFILE #:	OR321468
LINE ITEM:	9b.1
QUANTITY:	1 DT
RECEIVED DATE:	08/23/13
DISPOSAL PROCESS(ES):	LANDFILL
FINAL DISPOSAL LOCATION:	LANDFILL 13
DISPOSAL DATE:	08/23/13

I certify, on behalf of the above listed treatment facility, that to the best of my knowledge, the above-described waste material was managed in compliance with all applicable laws, regulations, permits and licenses on the date listed above.

Bobbi Jo Galvin

CWMNW RECORDS DEPARTMENT
Date: 08/30/13



CHEMICAL WASTE MANAGEMENT OF THE NW

17629 Cedar Springs Lane
Arlington, OR 97812
(541) 454-2643
(541) 454-3279 Fax

PORT OF TACOMA
WAD001882984
3400 TAYLOR WAY
TACOMA WA 98421

CERTIFICATE OF DISPOSAL

Chemical Waste Management of the Northwest, Inc., ORD089452353, has received the following waste material:

GENERATOR:	PORT OF TACOMA
MANIFEST #:	011880599JJK
CWM TRACKING ID:	42745501
PROFILE #:	OR321468
LINE ITEM:	9b.1
QUANTITY:	1 DT
RECEIVED DATE:	08/23/13
DISPOSAL PROCESS(ES):	LANDFILL
FINAL DISPOSAL LOCATION:	LANDFILL 13
DISPOSAL DATE:	08/23/13

I certify, on behalf of the above listed treatment facility, that to the best of my knowledge, the above-described waste material was managed in compliance with all applicable laws, regulations, permits and licenses on the date listed above.

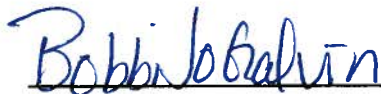

CWMNW RECORDS DEPARTMENT

Date: 08/30/13



CHEMICAL WASTE MANAGEMENT OF THE NW

17629 Cedar Springs Lane
Arlington, OR 97812
(541) 454-2643
(541) 454-3279 Fax

RECEIVED

SEP 23 2013

ENGINEERING DEPT.

PORT OF TACOMA
WAD001882984
3400 TAYLOR WAY
TACOMA WA 98421

CERTIFICATE OF DISPOSAL

Chemical Waste Management of the Northwest, Inc., ORD089452353, has received the following waste material:

GENERATOR:	PORT OF TACOMA
MANIFEST #:	011880585JJK
CWM TRACKING ID:	42743401
PROFILE #:	OR321468
LINE ITEM:	9b.1
QUANTITY:	1 DT
RECEIVED DATE:	08/23/13
DISPOSAL PROCESS(ES):	LANDFILL
FINAL DISPOSAL LOCATION:	LANDFILL 13
DISPOSAL DATE:	08/23/13

I certify, on behalf of the above listed treatment facility, that to the best of my knowledge, the above-described waste material was managed in compliance with all applicable laws, regulations, permits and licenses on the date listed above.



CWMNW RECORDS DEPARTMENT

Date: 08/30/13



CHEMICAL WASTE MANAGEMENT OF THE NW

17629 Cedar Springs Lane
Arlington, OR 97812
(541) 454-2643
(541) 454-3279 Fax

PORT OF TACOMA
WAD001882984
3400 TAYLOR WAY
TACOMA WA 98421

CERTIFICATE OF DISPOSAL

Chemical Waste Management of the Northwest, Inc., ORD089452353, has received the following waste material:

GENERATOR:	PORT OF TACOMA
MANIFEST #:	011880562JJK
CWM TRACKING ID:	42742901
PROFILE #:	OR321468
LINE ITEM:	9b.1
QUANTITY:	1 DT
RECEIVED DATE:	08/23/13
DISPOSAL PROCESS(ES):	LANDFILL
FINAL DISPOSAL LOCATION:	LANDFILL 13
DISPOSAL DATE:	08/23/13

I certify, on behalf of the above listed treatment facility, that to the best of my knowledge, the above-described waste material was managed in compliance with all applicable laws, regulations, permits and licenses on the date listed above.



CWMNW RECORDS DEPARTMENT

Date: 08/30/13



CHEMICAL WASTE MANAGEMENT OF THE NW

17629 Cedar Springs Lane
Arlington, OR 97812
(541) 454-2643
(541) 454-3279 Fax

PORT OF TACOMA
WAD001882984
3400 TAYLOR WAY
TACOMA WA 98421

CERTIFICATE OF DISPOSAL

Chemical Waste Management of the Northwest, Inc., ORD089452353, has received the following waste material:

GENERATOR:	PORT OF TACOMA
MANIFEST #:	011880586JJK
CWM TRACKING ID:	42743601
PROFILE #:	OR321648
LINE ITEM:	9b.1
QUANTITY:	1 DT
RECEIVED DATE:	08/23/13
DISPOSAL PROCESS(ES):	LANDFILL
FINAL DISPOSAL LOCATION:	LANDFILL 13
DISPOSAL DATE:	08/23/13

I certify, on behalf of the above listed treatment facility, that to the best of my knowledge, the above-described waste material was managed in compliance with all applicable laws, regulations, permits and licenses on the date listed above.

Bobbi J. Galvin

CWMNW RECORDS DEPARTMENT

Date: 09/03/13



CHEMICAL WASTE MANAGEMENT OF THE NW

17629 Cedar Springs Lane
Arlington, OR 97812
(541) 454-2643
(541) 454-3279 Fax

PORT OF TACOMA
WAD001882984
3400 TAYLOR WAY
TACOMA WA 98421

CERTIFICATE OF DISPOSAL

Chemical Waste Management of the Northwest, Inc., ORD089452353, has received the following waste material:

GENERATOR:	PORT OF TACOMA
MANIFEST #:	011880625JJK
CWM TRACKING ID:	42747701
PROFILE #:	OR321468
LINE ITEM:	9b.1
QUANTITY:	1 DT
RECEIVED DATE:	08/26/13
DISPOSAL PROCESS(ES):	LANDFILL
FINAL DISPOSAL LOCATION:	LANDFILL 13
DISPOSAL DATE:	08/26/13

I certify, on behalf of the above listed treatment facility, that to the best of my knowledge, the above-described waste material was managed in compliance with all applicable laws, regulations, permits and licenses on the date listed above.



CWMNW RECORDS DEPARTMENT

Date: 09/03/13



CHEMICAL WASTE MANAGEMENT OF THE NW

17629 Cedar Springs Lane
Arlington, OR 97812
(541) 454-2643
(541) 454-3279 Fax

PORT OF TACOMA
WAD001882984
3400 TAYLOR WAY
TACOMA WA 98421

CERTIFICATE OF DISPOSAL

Chemical Waste Management of the Northwest, Inc., ORD089452353, has received the following waste material:

GENERATOR:	PORT OF TACOMA
MANIFEST #:	011880614JJK
CWM TRACKING ID:	42747801
PROFILE #:	OR321468
LINE ITEM:	9b.1
QUANTITY:	1 DT
RECEIVED DATE:	08/26/13
DISPOSAL PROCESS(ES):	LANDFILL
FINAL DISPOSAL LOCATION:	LANDFILL 13
DISPOSAL DATE:	08/26/13

I certify, on behalf of the above listed treatment facility, that to the best of my knowledge, the above-described waste material was managed in compliance with all applicable laws, regulations, permits and licenses on the date listed above.

Bobbi b Balvin

CWMNW RECORDS DEPARTMENT

Date: 09/03/13



CHEMICAL WASTE MANAGEMENT OF THE NW

17629 Cedar Springs Lane
Arlington, OR 97812
(541) 454-2643
(541) 454-3279 Fax

PORT OF TACOMA
WAD001882984
3400 TAYLOR WAY
TACOMA WA 98421

CERTIFICATE OF DISPOSAL

Chemical Waste Management of the Northwest, Inc., ORD089452353, has received the following waste material:

GENERATOR:	PORT OF TACOMA
MANIFEST #:	011880628JJK
CWM TRACKING ID:	42747901
PROFILE #:	OR321468
LINE ITEM:	9b.1
QUANTITY:	1 DT
RECEIVED DATE:	08/26/13
DISPOSAL PROCESS(ES):	LANDFILL
FINAL DISPOSAL LOCATION:	LANDFILL 13
DISPOSAL DATE:	08/26/13

I certify, on behalf of the above listed treatment facility, that to the best of my knowledge, the above-described waste material was managed in compliance with all applicable laws, regulations, permits and licenses on the date listed above.



CWMNW RECORDS DEPARTMENT

Date: 09/03/13



CHEMICAL WASTE MANAGEMENT OF THE NW

17629 Cedar Springs Lane
Arlington, OR 97812
(541) 454-2643
(541) 454-3279 Fax

PORT OF TACOMA
WAD001882984
3400 TAYLOR WAY
TACOMA WA 98421

CERTIFICATE OF DISPOSAL

Chemical Waste Management of the Northwest, Inc., ORD089452353, has received the following waste material:

GENERATOR:	PORT OF TACOMA
MANIFEST #:	011880611JJK
CWM TRACKING ID:	42748101
PROFILE #:	OR321468
LINE ITEM:	9b.1
QUANTITY:	1 DT
RECEIVED DATE:	08/26/13
DISPOSAL PROCESS(ES):	LANDFILL
FINAL DISPOSAL LOCATION:	LANDFILL 13
DISPOSAL DATE:	08/26/13

I certify, on behalf of the above listed treatment facility, that to the best of my knowledge, the above-described waste material was managed in compliance with all applicable laws, regulations, permits and licenses on the date listed above.

Robert Jo Galvin

CWMNW RECORDS DEPARTMENT

Date: 09/03/13



CHEMICAL WASTE MANAGEMENT OF THE NW

17629 Cedar Springs Lane
Arlington, OR 97812
(541) 454-2643
(541) 454-3279 Fax

PORT OF TACOMA
WAD001882984
3400 TAYLOR WAY
TACOMA WA 98421

CERTIFICATE OF DISPOSAL

Chemical Waste Management of the Northwest, Inc., ORD089452353, has received the following waste material:

GENERATOR:	PORT OF TACOMA
MANIFEST #:	011880610JJK
CWM TRACKING ID:	42748201
PROFILE #:	OR321468
LINE ITEM:	9b.1
QUANTITY:	1 DT
RECEIVED DATE:	08/26/13
DISPOSAL PROCESS(ES):	LANDFILL
FINAL DISPOSAL LOCATION:	LANDFILL 13
DISPOSAL DATE:	08/26/13

I certify, on behalf of the above listed treatment facility, that to the best of my knowledge, the above-described waste material was managed in compliance with all applicable laws, regulations, permits and licenses on the date listed above.



CWMNW RECORDS DEPARTMENT

Date: 09/03/13



CHEMICAL WASTE MANAGEMENT OF THE NW

17629 Cedar Springs Lane
Arlington, OR 97812
(541) 454-2643
(541) 454-3279 Fax

PORT OF TACOMA
WAD001882984
3400 TAYLOR WAY
TACOMA WA 98421

CERTIFICATE OF DISPOSAL

Chemical Waste Management of the Northwest, Inc., ORD089452353, has received the following waste material:

GENERATOR:	PORT OF TACOMA
MANIFEST #:	011880618JJK
CWM TRACKING ID:	42748301
PROFILE #:	OR321468
LINE ITEM:	9b.1
QUANTITY:	1 DT
RECEIVED DATE:	08/26/13
DISPOSAL PROCESS(ES):	LANDFILL
FINAL DISPOSAL LOCATION:	LANDFILL 13
DISPOSAL DATE:	08/26/13

I certify, on behalf of the above listed treatment facility, that to the best of my knowledge, the above-described waste material was managed in compliance with all applicable laws, regulations, permits and licenses on the date listed above.

Robbie Galvin

CWMNW RECORDS DEPARTMENT

Date: 09/03/13



CHEMICAL WASTE MANAGEMENT OF THE NW

17629 Cedar Springs Lane
Arlington, OR 97812
(541) 454-2643
(541) 454-3279 Fax

PORT OF TACOMA
WAD001882984
3400 TAYLOR WAY
TACOMA WA 98421

CERTIFICATE OF DISPOSAL

Chemical Waste Management of the Northwest, Inc., ORD089452353, has received the following waste material:

GENERATOR:	PORT OF TACOMA
MANIFEST #:	011880617JJK
CWM TRACKING ID:	42748401
PROFILE #:	OR321468
LINE ITEM:	9b.1
QUANTITY:	1 DT
RECEIVED DATE:	08/26/13
DISPOSAL PROCESS(ES):	LANDFILL
FINAL DISPOSAL LOCATION:	LANDFILL 13
DISPOSAL DATE:	08/26/13

I certify, on behalf of the above listed treatment facility, that to the best of my knowledge, the above-described waste material was managed in compliance with all applicable laws, regulations, permits and licenses on the date listed above.

Bobbi Galvin

CWMNW RECORDS DEPARTMENT

Date: 09/03/13



CHEMICAL WASTE MANAGEMENT OF THE NW

17629 Cedar Springs Lane
Arlington, OR 97812
(541) 454-2643
(541) 454-3279 Fax

PORT OF TACOMA
WAD001882984
3400 TAYLOR WAY
TACOMA WA 98421

CERTIFICATE OF DISPOSAL

Chemical Waste Management of the Northwest, Inc., ORD089452353, has received the following waste material:

GENERATOR:	PORT OF TACOMA
MANIFEST #:	011880615JJK
CWM TRACKING ID:	42748501
PROFILE #:	OR321468
LINE ITEM:	9b.1
QUANTITY:	1 DT
RECEIVED DATE:	08/26/13
DISPOSAL PROCESS(ES):	LANDFILL
FINAL DISPOSAL LOCATION:	LANDFILL 13
DISPOSAL DATE:	08/26/13

I certify, on behalf of the above listed treatment facility, that to the best of my knowledge, the above-described waste material was managed in compliance with all applicable laws, regulations, permits and licenses on the date listed above.

Bobbi Jo Galvin

CWMNW RECORDS DEPARTMENT

Date: 09/03/13



CHEMICAL WASTE MANAGEMENT OF THE NW

17629 Cedar Springs Lane
Arlington, OR 97812
(541) 454-2643
(541) 454-3279 Fax

PORT OF TACOMA
WAD001882984
3400 TAYLOR WAY
TACOMA WA 98421

CERTIFICATE OF DISPOSAL

Chemical Waste Management of the Northwest, Inc., ORD089452353, has received the following waste material:

GENERATOR:	PORT OF TACOMA
MANIFEST #:	011880593JJK
CWM TRACKING ID:	42748601
PROFILE #:	OR321468
LINE ITEM:	9b.1
QUANTITY:	1 DT
RECEIVED DATE:	08/26/13
DISPOSAL PROCESS(ES):	LANDFILL
FINAL DISPOSAL LOCATION:	LANDFILL 13
DISPOSAL DATE:	08/26/13

I certify, on behalf of the above listed treatment facility, that to the best of my knowledge, the above-described waste material was managed in compliance with all applicable laws, regulations, permits and licenses on the date listed above.

Bobbi Galvin

CWMNW RECORDS DEPARTMENT

Date: 09/03/13



CHEMICAL WASTE MANAGEMENT OF THE NW

17629 Cedar Springs Lane
Arlington, OR 97812
(541) 454-2643
(541) 454-3279 Fax

PORT OF TACOMA
WAD001882984
3400 TAYLOR WAY
TACOMA WA 98421

CERTIFICATE OF DISPOSAL

Chemical Waste Management of the Northwest, Inc., ORD089452353, has received the following waste material:

GENERATOR:	PORT OF TACOMA
MANIFEST #:	011880613JJK
CWM TRACKING ID:	42748701
PROFILE #:	OR321468
LINE ITEM:	9b.1
QUANTITY:	1 DT
RECEIVED DATE:	08/26/13
DISPOSAL PROCESS(ES):	LANDFILL
FINAL DISPOSAL LOCATION:	LANDFILL 13
DISPOSAL DATE:	08/26/13

I certify, on behalf of the above listed treatment facility, that to the best of my knowledge, the above-described waste material was managed in compliance with all applicable laws, regulations, permits and licenses on the date listed above.

Bobbi Jobalvin

CWMNW RECORDS DEPARTMENT

Date: 09/03/13



CHEMICAL WASTE MANAGEMENT OF THE NW

17629 Cedar Springs Lane
Arlington, OR 97812
(541) 454-2643
(541) 454-3279 Fax

PORT OF TACOMA
WAD001882984
3400 TAYLOR WAY
TACOMA WA 98421

CERTIFICATE OF DISPOSAL

Chemical Waste Management of the Northwest, Inc., ORD089452353, has received the following waste material:

GENERATOR:	PORT OF TACOMA
MANIFEST #:	011880612JJK
CWM TRACKING ID:	42748801
PROFILE #:	OR321468
LINE ITEM:	9b.1
QUANTITY:	1 DT
RECEIVED DATE:	08/26/13
DISPOSAL PROCESS(ES):	LANDFILL
FINAL DISPOSAL LOCATION:	LANDFILL 13
DISPOSAL DATE:	08/26/13

I certify, on behalf of the above listed treatment facility, that to the best of my knowledge, the above-described waste material was managed in compliance with all applicable laws, regulations, permits and licenses on the date listed above.



CWMNW RECORDS DEPARTMENT

Date: 09/03/13



CHEMICAL WASTE MANAGEMENT OF THE NW

17629 Cedar Springs Lane
Arlington, OR 97812
(541) 454-2643
(541) 454-3279 Fax

PORT OF TACOMA
WAD001882984
3400 TAYLOR WAY
TACOMA WA 98421

CERTIFICATE OF DISPOSAL

Chemical Waste Management of the Northwest, Inc., ORD089452353, has received the following waste material:

GENERATOR:	PORT OF TACOMA
MANIFEST #:	011880622JJK
CWM TRACKING ID:	42748901
PROFILE #:	OR321468
LINE ITEM:	9b.1
QUANTITY:	1 DT
RECEIVED DATE:	08/26/13
DISPOSAL PROCESS(ES):	LANDFILL
FINAL DISPOSAL LOCATION:	LANDFILL 13
DISPOSAL DATE:	08/26/13

I certify, on behalf of the above listed treatment facility, that to the best of my knowledge, the above-described waste material was managed in compliance with all applicable laws, regulations, permits and licenses on the date listed above.

Bobbi Jo Galvin

CWMNW RECORDS DEPARTMENT

Date: 09/03/13



CHEMICAL WASTE MANAGEMENT OF THE NW

17629 Cedar Springs Lane
Arlington, OR 97812
(541) 454-2643
(541) 454-3279 Fax

PORT OF TACOMA
WAD001882984
3400 TAYLOR WAY
TACOMA WA 98421

CERTIFICATE OF DISPOSAL

Chemical Waste Management of the Northwest, Inc., ORD089452353, has received the following waste material:

GENERATOR:	PORT OF TACOMA
MANIFEST #:	011880623JJK
CWM TRACKING ID:	42749001
PROFILE #:	OR321468
LINE ITEM:	9b.1
QUANTITY:	1 D ₁
RECEIVED DATE:	08/26/13
DISPOSAL PROCESS(ES):	LANDFILL
FINAL DISPOSAL LOCATION:	LANDFILL 13
DISPOSAL DATE:	08/26/13

I certify, on behalf of the above listed treatment facility, that to the best of my knowledge, the above-described waste material was managed in compliance with all applicable laws, regulations, permits and licenses on the date listed above.



CWMNW RECORDS DEPARTMENT

Date: 09/03/13



CHEMICAL WASTE MANAGEMENT OF THE NW

17629 Cedar Springs Lane
Arlington, OR 97812
(541) 454-2643
(541) 454-3279 Fax

PORT OF TACOMA
WAD001882984
3400 TAYLOR WAY
TACOMA WA 98421

CERTIFICATE OF DISPOSAL

Chemical Waste Management of the Northwest, Inc., ORD089452353, has received the following waste material:

GENERATOR:	PORT OF TACOMA
MANIFEST #:	011880591JJK
CWM TRACKING ID:	42749101
PROFILE #:	OR321468
LINE ITEM:	9b.1
QUANTITY:	1 DT
RECEIVED DATE:	08/26/13
DISPOSAL PROCESS(ES):	LANDFILL
FINAL DISPOSAL LOCATION:	LANDFILL 13
DISPOSAL DATE:	08/26/13

I certify, on behalf of the above listed treatment facility, that to the best of my knowledge, the above-described waste material was managed in compliance with all applicable laws, regulations, permits and licenses on the date listed above.

Bobbi Jo Galvin

CWMNW RECORDS DEPARTMENT

Date: 09/03/13



CHEMICAL WASTE MANAGEMENT OF THE NW

17629 Cedar Springs Lane
Arlington, OR 97812
(541) 454-2643
(541) 454-3279 Fax

PORT OF TACOMA
WAD001882984
3400 TAYLOR WAY
TACOMA WA 98421

CERTIFICATE OF DISPOSAL

Chemical Waste Management of the Northwest, Inc., ORD089452353, has received the following waste material:

GENERATOR:	PORT OF TACOMA
MANIFEST #:	011880620JJK
CWM TRACKING ID:	42747201
PROFILE #:	OR321468
LINE ITEM:	9b.1
QUANTITY:	1 DT
RECEIVED DATE:	08/26/13
DISPOSAL PROCESS(ES):	LANDFILL
FINAL DISPOSAL LOCATION:	LANDFILL 13
DISPOSAL DATE:	08/26/13

I certify, on behalf of the above listed treatment facility, that to the best of my knowledge, the above-described waste material was managed in compliance with all applicable laws, regulations, permits and licenses on the date listed above.

Bobbi Jo Galvin

CWMNW RECORDS DEPARTMENT

Date: 09/03/13



CHEMICAL WASTE MANAGEMENT OF THE NW

17629 Cedar Springs Lane
Arlington, OR 97812
(541) 454-2643
(541) 454-3279 Fax

PORT OF TACOMA
WAD001882984
3400 TAYLOR WAY
TACOMA WA 98421

CERTIFICATE OF DISPOSAL

Chemical Waste Management of the Northwest, Inc., ORD089452353, has received the following waste material:

GENERATOR:	PORT OF TACOMA
MANIFEST #:	011880621JJK
CWM TRACKING ID:	42747501
PROFILE #:	OR321468
LINE ITEM:	9b.1
QUANTITY:	1 DT
RECEIVED DATE:	08/26/13
DISPOSAL PROCESS(ES):	LANDFILL
FINAL DISPOSAL LOCATION:	LANDFILL 13
DISPOSAL DATE:	08/26/13

I certify, on behalf of the above listed treatment facility, that to the best of my knowledge, the above-described waste material was managed in compliance with all applicable laws, regulations, permits and licenses on the date listed above.



CWMNW RECORDS DEPARTMENT

Date: 09/03/13



CHEMICAL WASTE MANAGEMENT OF THE NW

17629 Cedar Springs Lane
Arlington, OR 97812
(541) 454-2643
(541) 454-3279 Fax

PORT OF TACOMA
WAD001882984
3400 TAYLOR WAY
TACOMA WA 98421

CERTIFICATE OF DISPOSAL

Chemical Waste Management of the Northwest, Inc., ORD089452353, has received the following waste material:

GENERATOR:	PORT OF TACOMA
MANIFEST #:	011880624JJK
CWM TRACKING ID:	42747101
PROFILE #:	OR321468
LINE ITEM:	9b.1
QUANTITY:	1 DT
RECEIVED DATE:	08/26/13
DISPOSAL PROCESS(ES):	LANDFILL
FINAL DISPOSAL LOCATION:	LANDFILL 13
DISPOSAL DATE:	08/25/13

I certify, on behalf of the above listed treatment facility, that to the best of my knowledge, the above-described waste material was managed in compliance with all applicable laws, regulations, permits and licenses on the date listed above.



CWMNW RECORDS DEPARTMENT

Date: 09/03/13



CHEMICAL WASTE MANAGEMENT OF THE NW

17629 Cedar Springs Lane
Arlington, OR 97812
(541) 454-2643
(541) 454-3279 Fax

PORT OF TACOMA
WAD001882984
3400 TAYLOR WAY
TACOMA WA 98421

CERTIFICATE OF DISPOSAL

Chemical Waste Management of the Northwest, Inc., ORD089452353, has received the following waste material:

GENERATOR:	PORT OF TACOMA
MANIFEST #:	011880626JJK
CWM TRACKING ID:	42747001
PROFILE #:	OR321468
LINE ITEM:	9b.1
QUANTITY:	1 DT
RECEIVED DATE:	08/26/13
DISPOSAL PROCESS(ES):	LANDFILL
FINAL DISPOSAL LOCATION:	LANDFILL 13
DISPOSAL DATE:	08/26/13

I certify, on behalf of the above listed treatment facility, that to the best of my knowledge, the above-described waste material was managed in compliance with all applicable laws, regulations, permits and licenses on the date listed above.



CWMNW RECORDS DEPARTMENT

Date: 09/03/13



CHEMICAL WASTE MANAGEMENT OF THE NW

17629 Cedar Springs Lane
Arlington, OR 97812
(541) 454-2643
(541) 454-3279 Fax

PORT OF TACOMA
WAD001882984
3400 TAYLOR WAY
TACOMA WA 98421

CERTIFICATE OF DISPOSAL

Chemical Waste Management of the Northwest, Inc., ORD089452353, has received the following waste material:

GENERATOR:	PORT OF TACOMA
MANIFEST #:	011880631JJK
CWM TRACKING ID:	42746501
PROFILE #:	OR?21468
LINE ITEM:	9b.1
QUANTITY:	1 DT
RECEIVED DATE:	08/26/13
DISPOSAL PROCESS(ES):	LANDFILL
FINAL DISPOSAL LOCATION:	LANDFILL 13
DISPOSAL DATE:	08/26/13

I certify, on behalf of the above listed treatment facility, that to the best of my knowledge, the above-described waste material was managed in compliance with all applicable laws, regulations, permits and licenses on the date listed above.

Bobbi Jo Galvin

CWMNW RECORDS DEPARTMENT

Date: 09/03/13



CHEMICAL WASTE MANAGEMENT OF THE NW

17629 Cedar Springs Lane
Arlington, OR 97812
(541) 454-2643
(541) 454-3279 Fax

PORT OF TACOMA
WAD001882984
3400 TAYLOR WAY
TACOMA WA 98421

CERTIFICATE OF DISPOSAL

Chemical Waste Management of the Northwest, Inc., ORD089452353, has received the following waste material:

GENERATOR:	PORT OF TACOMA
MANIFEST #:	011880630JJK
CWM TRACKING ID:	42746401
PROFILE #:	OR321468
LINE ITEM:	9b.1
QUANTITY:	1 DT
RECEIVED DATE:	08/26/13
DISPOSAL PROCESS(ES):	LANDFILL
FINAL DISPOSAL LOCATION:	LANDFILL 13
DISPOSAL DATE:	08/26/13

I certify, on behalf of the above listed treatment facility, that to the best of my knowledge, the above-described waste material was managed in compliance with all applicable laws, regulations, permits and licenses on the date listed above.



CWMNW RECORDS DEPARTMENT
Date: 09/03/13



CHEMICAL WASTE MANAGEMENT OF THE NW

17629 Cedar Springs Lane
Arlington, OR 97812
(541) 454-2643
(541) 454-3279 Fax

PORT OF TACOMA
WAD001882984
3400 TAYLOR WAY
TACOMA WA 98421

CERTIFICATE OF DISPOSAL

Chemical Waste Management of the Northwest, Inc., ORD089452353, has received the following waste material:

GENERATOR:	PORT OF TACOMA
MANIFEST #:	011880627JJK
CWM TRACKING ID:	42746601
PROFILE #:	OR321468
LINE ITEM:	9b.1
QUANTITY:	1 DT
RECEIVED DATE:	08/26/13
DISPOSAL PROCESS(ES):	LANDFILL
FINAL DISPOSAL LOCATION:	LANDFILL 13
DISPOSAL DATE:	08/26/13

I certify, on behalf of the above listed treatment facility, that to the best of my knowledge, the above-described waste material was managed in compliance with all applicable laws, regulations, permits and licenses on the date listed above.

Bobbi Jo Galum _____

CWMNW RECORDS DEPARTMENT

Date: 09/05/13



CHEMICAL WASTE MANAGEMENT OF THE NW

17629 Cedar Springs Lane
Arlington, OR 97812
541 454 2643

PORT OF TACOMA
WAD001882984
3400 TAYLOR WAY
TACOMA WA 98421

CERTIFICATE OF DISPOSAL

Chemical Waste Management of the Northwest, Inc., ORD089452353, has received the following waste material:

GENERATOR:	PORT OF TACOMA
MANIFEST #:	011880619JJK
CWM TRACKING ID:	42746901
PROFILE #:	OR321468
LINE ITEM:	9b.1
QUANTITY:	1 DT
RECEIVED DATE:	08/26/13
DISPOSAL PROCESS(ES):	LANDFILL
FINAL DISPOSAL LOCATION:	LANDFILL 13
DISPOSAL DATE:	08/26/13

I certify, on behalf of the above listed treatment facility, that to the best of my knowledge, the above-described waste material was managed in compliance with all applicable laws, regulations, permits and licenses on the date listed above.

CWMNW RECORDS DEPARTMENT

Date: 08/26/13



CHEMICAL WASTE MANAGEMENT OF THE NW

17629 Cedar Springs Lane
Arlington, OR 97812
(541) 454-2643
(541) 454-3279 Fax

PORT OF TACOMA
WAD001882984
3400 TAYLOR WAY
TACOMA WA 98421

CERTIFICATE OF DISPOSAL

Chemical Waste Management of the Northwest, Inc., ORD089452353, has received the following waste material:

GENERATOR:	PORT OF TACOMA
MANIFEST #:	011880629JJK
CWM TRACKING ID:	42746701
PROFILE #:	OR321468
LINE ITEM:	9b.1
QUANTITY:	1 DT
RECEIVED DATE:	08/26/13
DISPOSAL PROCESS(ES):	LANDFILL
FINAL DISPOSAL LOCATION:	LANDFILL 13
DISPOSAL DATE:	08/26/13

I certify, on behalf of the above listed treatment facility, that to the best of my knowledge, the above-described waste material was managed in compliance with all applicable laws, regulations, permits and licenses on the date listed above.

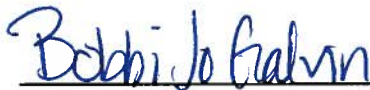

CWMNW RECORDS DEPARTMENT
Date:

09/03/13



CHEMICAL WASTE MANAGEMENT OF THE NW

17629 Cedar Springs Lane
Arlington, OR 97812
(541) 454-2643
(541) 454-3279 Fax

PORT OF TACOMA
WAD001882984
3400 TAYLOR WAY
TACOMA WA 98421

CERTIFICATE OF DISPOSAL

Chemical Waste Management of the Northwest, Inc., ORD089452353, has received the following waste material:

GENERATOR:	PORT OF TACOMA
MANIFEST #:	011080634JJK
CWM TRACKING ID:	42754001
PROFILE #:	OR321468
LINE ITEM:	9b.1
QUANTITY:	1 DT
RECEIVED DATE:	08/27/13
DISPOSAL PROCESS(ES):	LANDFILL
FINAL DISPOSAL LOCATION:	LANDFILL 13
DISPOSAL DATE:	08/27/13

I certify, on behalf of the above listed treatment facility, that to the best of my knowledge, the above-described waste material was managed in compliance with all applicable laws, regulations, permits and licenses on the date listed above.



CWMNW RECORDS DEPARTMENT

Date: 09/05/13



CHEMICAL WASTE MANAGEMENT OF THE NW

17629 Cedar Springs Lane
Arlington, OR 97812
(541) 454-2643
(541) 454-3279 Fax

PORT OF TACOMA
WAD001882984
3400 TAYLOR WAY
TACOMA WA 98421

CERTIFICATE OF DISPOSAL

Chemical Waste Management of the Northwest, Inc., ORD089452353, has received the following waste material:

GENERATOR:	PORT OF TACOMA
MANIFEST #:	011880672JJK
CWM TRACKING ID:	42753901
PROFILE #:	OR321468
LINE ITEM:	9b.1
QUANTITY:	1 DT
RECEIVED DATE:	08/27/13
DISPOSAL PROCESS(ES):	LANDFILL
FINAL DISPOSAL LOCATION:	LANDFILL 13
DISPOSAL DATE:	08/27/13

I certify, on behalf of the above listed treatment facility, that to the best of my knowledge, the above-described waste material was managed in compliance with all applicable laws, regulations, permits and licenses on the date listed above.

Robbin Galvin

CWMNW RECORDS DEPARTMENT

Date: 09/05/13



CHEMICAL WASTE MANAGEMENT OF THE NW

17629 Cedar Springs Lane
Arlington, OR 97812
(541) 454-2643
(541) 454-3279 Fax

RECEIVED

SEP 23 2013

ENGINEERING DEPT.

PORT OF TACOMA
WAD001882984
3400 TAYLOR WAY
TACOMA WA 98421

CERTIFICATE OF DISPOSAL

Chemical Waste Management of the Northwest, Inc., ORD089452353, has received the following waste material:

GENERATOR:	PORT OF TACOMA
MANIFEST #:	011880680JJK
CWM TRACKING ID:	42753801
PROFILE #:	OR321468
LINE ITEM:	9b.1
QUANTITY:	1 DT
RECEIVED DATE:	08/27/13
DISPOSAL PROCESS(ES):	LANDFILL
FINAL DISPOSAL LOCATION:	LANDFILL 13
DISPOSAL DATE:	08/27/13

I certify, on behalf of the above listed treatment facility, that to the best of my knowledge, the above-described waste material was managed in compliance with all applicable laws, regulations, permits and licenses on the date listed above.



CWMNW RECORDS DEPARTMENT

Date: 09/05/13



CHEMICAL WASTE MANAGEMENT OF THE NW

17629 Cedar Springs Lane
Arlington, OR 97812
(541) 454-2643
(541) 454-3279 Fax

PORT OF TACOMA
WAD001882984
3400 TAYLOR WAY
TACOMA WA 98421

CERTIFICATE OF DISPOSAL

Chemical Waste Management of the Northwest, Inc., ORD089452353, has received the following waste material:

GENERATOR:	PORT OF TACOMA
MANIFEST #:	011880677JJK
CWM TRACKING ID:	42753701
PROFILE #:	OR321468
LINE ITEM:	9b.1
QUANTITY:	1 DT
RECEIVED DATE:	08/27/13
DISPOSAL PROCESS(ES):	LANDFILL
FINAL DISPOSAL LOCATION:	LANDFILL 13
DISPOSAL DATE:	08/27/13

I certify, on behalf of the above listed treatment facility, that to the best of my knowledge, the above-described waste material was managed in compliance with all applicable laws, regulations, permits and licenses on the date listed above.

Bobbi Galvin

CWMNW RECORDS DEPARTMENT

Date: 09/05/13



CHEMICAL WASTE MANAGEMENT OF THE NW

17629 Cedar Springs Lane
Arlington, OR 97812
(541) 454-2643
(541) 454-3279 Fax

PORT OF TACOMA
WAD001882984
3400 TAYLOR WAY
TACOMA WA 98421

CERTIFICATE OF DISPOSAL

Chemical Waste Management of the Northwest, Inc., ORD089452353, has received the following waste material:

GENERATOR:	PORT OF TACOMA
MANIFEST #:	011880671JJK
CWM TRACKING ID:	42753601
PROFILE #:	OR321468
LINE ITEM:	9b.1
QUANTITY:	1 DT
RECEIVED DATE:	08/27/13
DISPOSAL PROCESS(ES):	LANDFILL
FINAL DISPOSAL LOCATION:	LANDFILL 13
DISPOSAL DATE:	08/27/13

I certify, on behalf of the above listed treatment facility, that to the best of my knowledge, the above-described waste material was managed in compliance with all applicable laws, regulations, permits and licenses on the date listed above.



CWMNW RECORDS DEPARTMENT

Date: 09/05/13



CHEMICAL WASTE MANAGEMENT OF THE NW

17629 Cedar Springs Lane
Arlington, OR 97812
(541) 454-2643
(541) 454-3279 Fax

PORT OF TACOMA
WAD001882984
3400 TAYLOR WAY
TACOMA WA 98421

CERTIFICATE OF DISPOSAL

Chemical Waste Management of the Northwest, Inc., ORD089452353, has received the following waste material:

GENERATOR:	PORT OF TACOMA
MANIFEST #:	011880642JJK
CWM TRACKING ID:	42753401
PROFILE #:	OR321468
LINE ITEM:	9b.1
QUANTITY:	1 DT
RECEIVED DATE:	08/27/13
DISPOSAL PROCESS(ES):	LANDFILL
FINAL DISPOSAL LOCATION:	LANDFILL 13
DISPOSAL DATE:	08/27/13

I certify, on behalf of the above listed treatment facility, that to the best of my knowledge, the above-described waste material was managed in compliance with all applicable laws, regulations, permits and licenses on the date listed above.



CWMNW RECORDS DEPARTMENT

Date: 09/05/13



CHEMICAL WASTE MANAGEMENT OF THE NW

17629 Cedar Springs Lane
Arlington, OR 97812
(541) 454-2643
(541) 454-3279 Fax

PORT OF TACOMA
WAD001882984
3400 TAYLOR WAY
TACOMA WA 98421

CERTIFICATE OF DISPOSAL

Chemical Waste Management of the Northwest, Inc., ORD089452353, has received the following waste material:

GENERATOR:	PORT OF TACOMA
MANIFEST #:	011880664JJK
CWM TRACKING ID:	42753301
PROFILE #:	OR321468
LINE ITEM:	9b.1
QUANTITY:	1 DT
RECEIVED DATE:	08/27/13
DISPOSAL PROCESS(ES):	LANDFILL
FINAL DISPOSAL LOCATION:	LANDFILL 13
DISPOSAL DATE:	08/27/13

I certify, on behalf of the above listed treatment facility, that to the best of my knowledge, the above-described waste material was managed in compliance with all applicable laws, regulations, permits and licenses on the date listed above.

Bobbi Jo Galvin

CWMNW RECORDS DEPARTMENT

Date: 09/05/13



CHEMICAL WASTE MANAGEMENT OF THE NW

17629 Cedar Springs Lane
Arlington, OR 97812
(541) 454-2643
(541) 454-3279 Fax

PORT OF TACOMA
WAD001882984
3400 TAYLOR WAY
TACOMA WA 98421

CERTIFICATE OF DISPOSAL

Chemical Waste Management of the Northwest, Inc., ORD089452353, has received the following waste material:

GENERATOR:	PORT OF TACOMA
MANIFEST #:	011880661JJK
CWM TRACKING ID:	42753201
PROFILE #:	OR321468
LINE ITEM:	9b.1
QUANTITY:	1 DT
RECEIVED DATE:	08/27/13
DISPOSAL PROCESS(ES):	LANDFILL
FINAL DISPOSAL LOCATION:	LANDFILL 13
DISPOSAL DATE:	08/27/13

I certify, on behalf of the above listed treatment facility, that to the best of my knowledge, the above-described waste material was managed in compliance with all applicable laws, regulations, permits and licenses on the date listed above.

Robb Jo Galvin

CWMNW RECORDS DEPARTMENT
Date: 09/05/13



CHEMICAL WASTE MANAGEMENT OF THE NW

17629 Cedar Springs Lane
Arlington, OR 97812
(541) 454-2643
(541) 454-3279 Fax

PORT OF TACOMA
WAD001882984
3400 TAYLOR WAY
TACOMA WA 98421

CERTIFICATE OF DISPOSAL

Chemical Waste Management of the Northwest, Inc., ORD089452353, has received the following waste material:

GENERATOR:	PORT OF TACOMA
MANIFEST #:	011880660JJK
CWM TRACKING ID:	42753101
PROFILE #:	OR321468
LINE ITEM:	9b.1
QUANTITY:	1 DT
RECEIVED DATE:	08/27/13
DISPOSAL PROCESS(ES):	LANDFILL
FINAL DISPOSAL LOCATION:	LANDFILL 13
DISPOSAL DATE:	08/27/13

I certify, on behalf of the above listed treatment facility, that to the best of my knowledge, the above-described waste material was managed in compliance with all applicable laws, regulations, permits and licenses on the date listed above.

Robbio Galvin

CWMNW RECORDS DEPARTMENT

Date: 09/05/13



CHEMICAL WASTE MANAGEMENT OF THE NW

17629 Cedar Springs Lane
Arlington, OR 97812
(541) 454-2643
(541) 454-3279 Fax

PORT OF TACOMA
WAD001882984
3400 TAYLOR WAY
TACOMA WA 98421

CERTIFICATE OF DISPOSAL

Chemical Waste Management of the Northwest, Inc., ORD089452353, has received the following waste material:

GENERATOR:	PORT OF TACOMA
MANIFEST #:	011880652JJK
CWM TRACKING ID:	42753001
PROFILE #:	OR321468
LINE ITEM:	9b.1
QUANTITY:	1 DT
RECEIVED DATE:	08/27/13
DISPOSAL PROCESS(ES):	LANDFILL
FINAL DISPOSAL LOCATION:	LANDFILL 13
DISPOSAL DATE:	08/27/13

I certify, on behalf of the above listed treatment facility, that to the best of my knowledge, the above-described waste material was managed in compliance with all applicable laws, regulations, permits and licenses on the date listed above.



CWMNW RECORDS DEPARTMENT

Date: 09/05/13



CHEMICAL WASTE MANAGEMENT OF THE NW

17629 Cedar Springs Lane
Arlington, OR 97812
(541) 454-2643
(541) 454-3279 Fax

PORT OF TACOMA
WAD001882984
3400 TAYLOR WAY
TACOMA WA 98421

CERTIFICATE OF DISPOSAL

Chemical Waste Management of the Northwest, Inc., ORD089452353, has received the following waste material:

GENERATOR:	PORT OF TACOMA
MANIFEST #:	011880641JJK
CWM TRACKING ID:	42752901
PROFILE #:	OR321468
LINE ITEM:	9b.1
QUANTITY:	1 DT
RECEIVED DATE:	08/27/13
DISPOSAL PROCESS(ES):	LANDFILL
FINAL DISPOSAL LOCATION:	LANDFILL 13
DISPOSAL DATE:	08/27/13

I certify, on behalf of the above listed treatment facility, that to the best of my knowledge, the above-described waste material was managed in compliance with all applicable laws, regulations, permits and licenses on the date listed above.

Bobbi Jo Galvin

CWMNW RECORDS DEPARTMENT

Date: 09/05/13



CHEMICAL WASTE MANAGEMENT OF THE NW

17629 Cedar Springs Lane
Arlington, OR 97812
(541) 454-2643
(541) 454-3279 Fax

PORT OF TACOMA
WAD001882984
3400 TAYLOR WAY
TACOMA WA 98421

CERTIFICATE OF DISPOSAL

Chemical Waste Management of the Northwest, Inc., ORD089452353, has received the following waste material:

GENERATOR:	PORT OF TACOMA
MANIFEST #:	011880635JJK
CWM TRACKING ID:	42752801
PROFILE #:	OR321468
LINE ITEM:	9b.1
QUANTITY:	1 DT
RECEIVED DATE:	08/27/13
DISPOSAL PROCESS(ES):	LANDFILL
FINAL DISPOSAL LOCATION:	LANDFILL 13
DISPOSAL DATE:	08/27/13

I certify, on behalf of the above listed treatment facility, that to the best of my knowledge, the above-described waste material was managed in compliance with all applicable laws, regulations, permits and licenses on the date listed above.

Bobbi Jo Galvin

CWMNW RECORDS DEPARTMENT

Date: 09/05/13



CHEMICAL WASTE MANAGEMENT OF THE NW

17629 Cedar Springs Lane
Arlington, OR 97812
(541) 454-2643
(541) 454-3279 Fax

PORT OF TACOMA
WAD001882984
3400 TAYLOR WAY
TACOMA WA 98421

CERTIFICATE OF DISPOSAL

Chemical Waste Management of the Northwest, Inc., ORD089452353, has received the following waste material:

GENERATOR:	PORT OF TACOMA
MANIFEST #:	011880616JJK
CWM TRACKING ID:	42752701
PROFILE #:	OR321468
LINE ITEM:	9b.1
QUANTITY:	1 DT
RECEIVED DATE:	08/27/13
DISPOSAL PROCESS(ES):	LANDFILL
FINAL DISPOSAL LOCATION:	LANDFILL 13
DISPOSAL DATE:	08/27/13

I certify, on behalf of the above listed treatment facility, that to the best of my knowledge, the above-described waste material was managed in compliance with all applicable laws, regulations, permits and licenses on the date listed above.



CWMNW RECORDS DEPARTMENT

Date: 09/05/13



CHEMICAL WASTE MANAGEMENT OF THE NW

17629 Cedar Springs Lane
Arlington, OR 97812
(541) 454-2643
(541) 454-3279 Fax

PORT OF TACOMA
WAD001882984
3400 TAYLOR WAY
TACOMA WA 98421

CERTIFICATE OF DISPOSAL

Chemical Waste Management of the Northwest, Inc., ORD089452353, has received the following waste material:

GENERATOR:	PORT OF TACOMA
MANIFEST #:	011880639JJK
CWM TRACKING ID:	42752601
PROFILE #:	OR321468
LINE ITEM:	9b.1
QUANTITY:	1 DT
RECEIVED DATE:	08/27/13
DISPOSAL PROCESS(ES):	LANDFILL
FINAL DISPOSAL LOCATION:	LANDFILL 13
DISPOSAL DATE:	08/27/13

I certify, on behalf of the above listed treatment facility, that to the best of my knowledge, the above-described waste material was managed in compliance with all applicable laws, regulations, permits and licenses on the date listed above.



CWMNW RECORDS DEPARTMENT

Date: 09/05/13



CHEMICAL WASTE MANAGEMENT OF THE NW

17629 Cedar Springs Lane
Arlington, OR 97812
(541) 454-2643
(541) 454-3279 Fax

PORT OF TACOMA
WAD001882984
3400 TAYLOR WAY
TACOMA WA 98421

CERTIFICATE OF DISPOSAL

Chemical Waste Management of the Northwest, Inc., ORD089452353, has received the following waste material:

GENERATOR:	PORT OF TACOMA
MANIFEST #:	011880640JJK
CWM TRACKING ID:	42752501
PROFILE #:	OR321468
LINE ITEM:	9b.1
QUANTITY:	1 DT
RECEIVED DATE:	08/27/13
DISPOSAL PROCESS(ES):	LANDFILL
FINAL DISPOSAL LOCATION:	LANDFILL 13
DISPOSAL DATE:	08/27/13

I certify, on behalf of the above listed treatment facility, that to the best of my knowledge, the above-described waste material was managed in compliance with all applicable laws, regulations, permits and licenses on the date listed above.



CWMNW RECORDS DEPARTMENT

Date: 09/05/13



CHEMICAL WASTE MANAGEMENT OF THE NW

17629 Cedar Springs Lane
Arlington, OR 97812
(541) 454-2643
(541) 454-3279 Fax

PORT OF TACOMA
WAD001882984
3400 TAYLOR WAY
TACOMA WA 98421

CERTIFICATE OF DISPOSAL

Chemical Waste Management of the Northwest, Inc., ORD089452353, has received the following waste material:

GENERATOR:	PORT OF TACOMA
MANIFEST #:	011880662JJK
CWM TRACKING ID:	42752401
PROFILE #:	OR321468
LINE ITEM:	9b.1
QUANTITY:	1 DT
RECEIVED DATE:	08/27/13
DISPOSAL PROCESS(ES):	LANDFILL
FINAL DISPOSAL LOCATION:	LANDFILL 13
DISPOSAL DATE:	08/27/13

I certify, on behalf of the above listed treatment facility, that to the best of my knowledge, the above-described waste material was managed in compliance with all applicable laws, regulations, permits and licenses on the date listed above.

Bobbi Jo Galvin

CWMNW RECORDS DEPARTMENT

Date: 09/05/13



CHEMICAL WASTE MANAGEMENT OF THE NW

17629 Cedar Springs Lane
Arlington, OR 97812
(541) 454-2643
(541) 454-3279 Fax

PORT OF TACOMA
WAD001882984
3400 TAYLOR WAY
TACOMA WA 98421

CERTIFICATE OF DISPOSAL

Chemical Waste Management of the Northwest, Inc., ORD089452353, has received the following waste material:

GENERATOR:	PORT OF TACOMA
MANIFEST #:	011880653JJK
CWM TRACKING ID:	42752301
PROFILE #:	OR321468
LINE ITEM:	9b.1
QUANTITY:	1 DT
RECEIVED DATE:	08/27/13
DISPOSAL PROCESS(ES):	LANDFILL
FINAL DISPOSAL LOCATION:	LANDFILL 13
DISPOSAL DATE:	08/27/13

I certify, on behalf of the above listed treatment facility, that to the best of my knowledge, the above-described waste material was managed in compliance with all applicable laws, regulations, permits and licenses on the date listed above.



CWMNW RECORDS DEPARTMENT

Date: 09/05/13



CHEMICAL WASTE MANAGEMENT OF THE NW

17629 Cedar Springs Lane
Arlington, OR 97812
(541) 454-2643
(541) 454-3279 Fax

PORT OF TACOMA
WAD001882984
3400 TAYLOR WAY
TACOMA WA 98421

CERTIFICATE OF DISPOSAL

Chemical Waste Management of the Northwest, Inc., ORD089452353, has received the following waste material:

GENERATOR:	PORT OF TACOMA
MANIFEST #:	011880650JJK
CWM TRACKING ID:	42752201
PROFILE #:	OR321468
LINE ITEM:	9b.1
QUANTITY:	1 DT
RECEIVED DATE:	08/27/13
DISPOSAL PROCESS(ES):	LANDFILL
FINAL DISPOSAL LOCATION:	LANDFILL 13
DISPOSAL DATE:	08/27/13

I certify, on behalf of the above listed treatment facility, that to the best of my knowledge, the above-described waste material was managed in compliance with all applicable laws, regulations, permits and licenses on the date listed above.



CWMNW RECORDS DEPARTMENT

Date: 09/05/13



CHEMICAL WASTE MANAGEMENT OF THE NW

17629 Cedar Springs Lane
Arlington, OR 97812
(541) 454-2643
(541) 454-3279 Fax

PORT OF TACOMA
WAD001882984
3400 TAYLOR WAY
TACOMA WA 98421

CERTIFICATE OF DISPOSAL

Chemical Waste Management of the Northwest, Inc., ORD089452353, has received the following waste material:

GENERATOR:	PORT OF TACOMA
MANIFEST #:	011880646JJK
CWM TRACKING ID:	42752101
PROFILE #:	OR321468
LINE ITEM:	9b.1
QUANTITY:	1 DT
RECEIVED DATE:	08/27/13
DISPOSAL PROCESS(ES):	LANDFILL
FINAL DISPOSAL LOCATION:	LANDFILL 13
DISPOSAL DATE:	08/27/13

I certify, on behalf of the above listed treatment facility, that to the best of my knowledge, the above-described waste material was managed in compliance with all applicable laws, regulations, permits and licenses on the date listed above.

Robbi Jo Galvin

CWMNW RECORDS DEPARTMENT

Date: 09/05/13



CHEMICAL WASTE MANAGEMENT OF THE NW

17629 Cedar Springs Lane
Arlington, OR 97812
(541) 454-2643
(541) 454-3279 Fax

PORT OF TACOMA
WAD001882984
3400 TAYLOR WAY
TACOMA WA 98421

CERTIFICATE OF DISPOSAL

Chemical Waste Management of the Northwest, Inc., ORD089452353, has received the following waste material:

GENERATOR:	PORT OF TACOMA
MANIFEST #:	011880648JJK
CWM TRACKING ID:	42751801
PROFILE #:	OR321468
LINE ITEM:	9b.1
QUANTITY:	1 DT
RECEIVED DATE:	08/27/13
DISPOSAL PROCESS(ES):	LANDFILL
FINAL DISPOSAL LOCATION:	LANDFILL 13
DISPOSAL DATE:	08/27/13

I certify, on behalf of the above listed treatment facility, that to the best of my knowledge, the above-described waste material was managed in compliance with all applicable laws, regulations, permits and licenses on the date listed above.

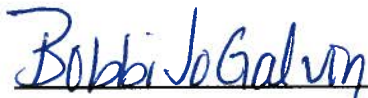

CWMNW RECORDS DEPARTMENT

Date: 09/05/13



CHEMICAL WASTE MANAGEMENT OF THE NW

17629 Cedar Springs Lane
Arlington, OR 97812
(541) 454-2643
(541) 454-3279 Fax

PORT OF TACOMA
WAD001882984
3400 TAYLOR WAY
TACOMA WA 98421

CERTIFICATE OF DISPOSAL

Chemical Waste Management of the Northwest, Inc., ORD089452353, has received the following waste material:

GENERATOR:	PORT OF TACOMA
MANIFEST #:	011880647JJK
CWM TRACKING ID:	42751701
PROFILE #:	OR321468
LINE ITEM:	9b.1
QUANTITY:	1 DT
RECEIVED DATE:	08/27/13
DISPOSAL PROCESS(ES):	LANDFILL
FINAL DISPOSAL LOCATION:	LANDFILL 13
DISPOSAL DATE:	08/27/13

I certify, on behalf of the above listed treatment facility, that to the best of my knowledge, the above-described waste material was managed in compliance with all applicable laws, regulations, permits and licenses on the date listed above.

Bobbi Jo Galvin

CWMNW RECORDS DEPARTMENT

Date: 09/05/13



CHEMICAL WASTE MANAGEMENT OF THE NW

17629 Cedar Springs Lane
Arlington, OR 97812
(541) 454-2643
(541) 454-3279 Fax

PORT OF TACOMA
WAD001882984
3400 TAYLOR WAY
TACOMA WA 98421

CERTIFICATE OF DISPOSAL

Chemical Waste Management of the Northwest, Inc., ORD089452353, has received the following waste material:

GENERATOR:	PORT OF TACOMA
MANIFEST #:	011880657JJK
CWM TRACKING ID:	42751601
PROFILE #:	OR321468
LINE ITEM:	9b.1
QUANTITY:	1 DT
RECEIVED DATE:	08/27/13
DISPOSAL PROCESS(ES):	LANDFILL
FINAL DISPOSAL LOCATION:	LANDFILL 13
DISPOSAL DATE:	08/27/13

I certify, on behalf of the above listed treatment facility, that to the best of my knowledge, the above-described waste material was managed in compliance with all applicable laws, regulations, permits and licenses on the date listed above.

Robbi Galvin

CWMNW RECORDS DEPARTMENT

Date: 09/05/13



CHEMICAL WASTE MANAGEMENT OF THE NW

17629 Cedar Springs Lane
Arlington, OR 97812
(541) 454-2643
(541) 454-3279 Fax

PORT OF TACOMA
WAD001882984
3400 TAYLOR WAY
TACOMA WA 98421

CERTIFICATE OF DISPOSAL

Chemical Waste Management of the Northwest, Inc., ORD089452353, has received the following waste material:

GENERATOR:	PORT OF TACOMA
MANIFEST #:	011880556JJK
CWM TRACKING ID:	42751501
PROFILE #:	OR321468
LINE ITEM:	9b.1
QUANTITY:	1 DT
RECEIVED DATE:	08/27/13
DISPOSAL PROCESS(ES):	LANDFILL
FINAL DISPOSAL LOCATION:	LANDFILL 13
DISPOSAL DATE:	08/27/13

I certify, on behalf of the above listed treatment facility, that to the best of my knowledge, the above-described waste material was managed in compliance with all applicable laws, regulations, permits and licenses on the date listed above.

Bobbi Jo Galvin

CWMNW RECORDS DEPARTMENT

Date: 09/05/13



CHEMICAL WASTE MANAGEMENT OF THE NW

17629 Cedar Springs Lane
Arlington, OR 97812
(541) 454-2643
(541) 454-3279 Fax

PORT OF TACOMA
WAD001882984
3400 TAYLOR WAY
TACOMA WA 98421

CERTIFICATE OF DISPOSAL

Chemical Waste Management of the Northwest, Inc., ORD089452353, has received the following waste material:

GENERATOR:	PORT OF TACOMA
MANIFEST #:	011880558JJK
CWM TRACKING ID:	42751401
PROFILE #:	OR321468
LINE ITEM:	9b.1
QUANTITY:	1 DT
RECEIVED DATE:	08/27/13
DISPOSAL PROCESS(ES):	LANDFILL
FINAL DISPOSAL LOCATION:	LANDFILL 13
DISPOSAL DATE:	08/27/13

I certify, on behalf of the above listed treatment facility, that to the best of my knowledge, the above-described waste material was managed in compliance with all applicable laws, regulations, permits and licenses on the date listed above.

Bobbi Jo Galvin

CWMNW RECORDS DEPARTMENT

Date: 09/05/13



CHEMICAL WASTE MANAGEMENT OF THE NW

17629 Cedar Springs Lane
Arlington, OR 97812
(541) 454-2643
(541) 454-3279 Fax

PORT OF TACOMA
WAD001882984
3400 TAYLOR WAY
TACOMA WA 98421

CERTIFICATE OF DISPOSAL

Chemical Waste Management of the Northwest, Inc., ORD089452353, has received the following waste material:

GENERATOR:	PORT OF TACOMA
MANIFEST #:	011880559JJK
CWM TRACKING ID:	42751001
PROFILE #:	OR321468
LINE ITEM:	9b.1
QUANTITY:	1 DT
RECEIVED DATE:	08/27/13
DISPOSAL PROCESS(ES):	LANDFILL
FINAL DISPOSAL LOCATION:	LANDFILL 13
DISPOSAL DATE:	08/27/13

I certify, on behalf of the above listed treatment facility, that to the best of my knowledge, the above-described waste material was managed in compliance with all applicable laws, regulations, permits and licenses on the date listed above.

Bobbi Jo Galvin

CWMNW RECORDS DEPARTMENT
Date: 09/05/13



CHEMICAL WASTE MANAGEMENT OF THE NW

17629 Cedar Springs Lane
Arlington, OR 97812
(541) 454-2643
(541) 454-3279 Fax

PORT OF TACOMA
WAD001882984
3400 TAYLOR WAY
TACOMA WA 98421

CERTIFICATE OF DISPOSAL

Chemical Waste Management of the Northwest, Inc., ORD089452353, has received the following waste material:

GENERATOR:	PORT OF TACOMA
MANIFEST #:	011880560JJK
CWM TRACKING ID:	42750901
PROFILE #:	OR321468
LINE ITEM:	9b.1
QUANTITY:	1 DT
RECEIVED DATE:	08/27/13
DISPOSAL PROCESS(ES):	LANDFILL
FINAL DISPOSAL LOCATION:	LANDFILL 13
DISPOSAL DATE:	08/27/13

I certify, on behalf of the above listed treatment facility, that to the best of my knowledge, the above-described waste material was managed in compliance with all applicable laws, regulations, permits and licenses on the date listed above.

Bobbi Jo Galvin

CWMNW RECORDS DEPARTMENT

Date: 09/05/13



CHEMICAL WASTE MANAGEMENT OF THE NW

17629 Cedar Springs Lane
Arlington, OR 97812
(541) 454-2643
(541) 454-3279 Fax

PORT OF TACOMA
WAD001882984
3400 TAYLOR WAY
TACOMA WA 98421

CERTIFICATE OF DISPOSAL

Chemical Waste Management of the Northwest, Inc., ORD089452353, has received the following waste material:

GENERATOR:	PORT OF TACOMA
MANIFEST #:	011880670JJK
CWM TRACKING ID:	42758301
PROFILE #:	OR321468
LINE ITEM:	9b.1
QUANTITY:	1 DT
RECEIVED DATE:	08/28/13
DISPOSAL PROCESS(ES):	LANDFILL
FINAL DISPOSAL LOCATION:	LANDFILL 13
DISPOSAL DATE:	08/28/13

I certify, on behalf of the above listed treatment facility, that to the best of my knowledge, the above-described waste material was managed in compliance with all applicable laws, regulations, permits and licenses on the date listed above.



CWMNW RECORDS DEPARTMENT

Date: 09/09/13



CHEMICAL WASTE MANAGEMENT OF THE NW

17629 Cedar Springs Lane
Arlington, OR 97812
(541) 454-2643
(541) 454-3279 Fax

PORT OF TACOMA
WAD001882984
3400 TAYLOR WAY
TACOMA WA 98421

CERTIFICATE OF DISPOSAL

Chemical Waste Management of the Northwest, Inc., ORD089452353, has received the following waste material:

GENERATOR:	PORT OF TACOMA
MANIFEST #:	011880685JJK
CWM TRACKING ID:	42758801
PROFILE #:	OR321468
LINE ITEM:	9b.1
QUANTITY:	1 DT
RECEIVED DATE:	08/28/13
DISPOSAL PROCESS(ES):	LANDFILL
FINAL DISPOSAL LOCATION:	LANDFILL 13
DISPOSAL DATE:	08/28/13

I certify, on behalf of the above listed treatment facility, that to the best of my knowledge, the above-described waste material was managed in compliance with all applicable laws, regulations, permits and licenses on the date listed above.



CWMNW RECORDS DEPARTMENT

Date: 09/09/13



CHEMICAL WASTE MANAGEMENT OF THE NW

17629 Cedar Springs Lane
Arlington, OR 97812
(541) 454-2643
(541) 454-3279 Fax

PORT OF TACOMA
WAD001882984
3400 TAYLOR WAY
TACOMA WA 98421

CERTIFICATE OF DISPOSAL

Chemical Waste Management of the Northwest, Inc., ORD089452353, has received the following waste material:

GENERATOR:	PORT OF TACOMA
MANIFEST #:	011880686JJK
CWM TRACKING ID:	42759001
PROFILE #:	OR321468
LINE ITEM:	9b.1
QUANTITY:	1 DT
RECEIVED DATE:	08/28/13
DISPOSAL PROCESS(ES):	LANDFILL
FINAL DISPOSAL LOCATION:	LANDFILL 13
DISPOSAL DATE:	08/28/13

I certify, on behalf of the above listed treatment facility, that to the best of my knowledge, the above-described waste material was managed in compliance with all applicable laws, regulations, permits and licenses on the date listed above.

Bobbi Jo Galvin

CWMNW RECORDS DEPARTMENT

Date: 09/09/13



CHEMICAL WASTE MANAGEMENT OF THE NW

17629 Cedar Springs Lane
Arlington, OR 97812
(541) 454-2643
(541) 454-3279 Fax

PORT OF TACOMA
WAD001882984
3400 TAYLOR WAY
TACOMA WA 98421

CERTIFICATE OF DISPOSAL

Chemical Waste Management of the Northwest, Inc., ORD089452353, has received the following waste material:

GENERATOR:	PORT OF TACOMA
MANIFEST #:	011880557JJK
CWM TRACKING ID:	42759101
PROFILE #:	OR321468
LINE ITEM:	9b.1
QUANTITY:	1 DT
RECEIVED DATE:	08/28/13
DISPOSAL PROCESS(ES):	LANDFILL
FINAL DISPOSAL LOCATION:	LANDFILL 13
DISPOSAL DATE:	08/28/13

I certify, on behalf of the above listed treatment facility, that to the best of my knowledge, the above-described waste material was managed in compliance with all applicable laws, regulations, permits and licenses on the date listed above.



CWMNW RECORDS DEPARTMENT

Date: 09/09/13



CHEMICAL WASTE MANAGEMENT OF THE NW

17629 Cedar Springs Lane
Arlington, OR 97812
(541) 454-2643
(541) 454-3279 Fax

PORT OF TACOMA
WAD001882984
3400 TAYLOR WAY
TACOMA WA 98421

CERTIFICATE OF DISPOSAL

Chemical Waste Management of the Northwest, Inc., ORD089452353, has received the following waste material:

GENERATOR:	PORT OF TACOMA
MANIFEST #:	011880675JJK
CWM TRACKING ID:	42757901
PROFILE #:	OR321468
LINE ITEM:	9b.1
QUANTITY:	1 DT
RECEIVED DATE:	08/28/13
DISPOSAL PROCESS(ES):	LANDFILL
FINAL DISPOSAL LOCATION:	LANDFILL 13
DISPOSAL DATE:	08/28/13

I certify, on behalf of the above listed treatment facility, that to the best of my knowledge, the above-described waste material was managed in compliance with all applicable laws, regulations, permits and licenses on the date listed above.

Bebbi J. Galvin

CWMNW RECORDS DEPARTMENT

Date: 09/09/13



CHEMICAL WASTE MANAGEMENT OF THE NW

17629 Cedar Springs Lane
Arlington, OR 97812
(541) 454-2643
(541) 454-3279 Fax

PORT OF TACOMA
WAD001882984
3400 TAYLOR WAY
TACOMA WA 98421

CERTIFICATE OF DISPOSAL

Chemical Waste Management of the Northwest, Inc., ORD089452353, has received the following waste material:

GENERATOR:	PORT OF TACOMA
MANIFEST #:	011880679JJK
CWM TRACKING ID:	42757701
PROFILE #:	OR321468
LINE ITEM:	9b.1
QUANTITY:	1 DT
RECEIVED DATE:	08/28/13
DISPOSAL PROCESS(ES):	LANDFILL
FINAL DISPOSAL LOCATION:	LANDFILL 13
DISPOSAL DATE:	08/28/13

I certify, on behalf of the above listed treatment facility, that to the best of my knowledge, the above-described waste material was managed in compliance with all applicable laws, regulations, permits and licenses on the date listed above.



CWMNW RECORDS DEPARTMENT

Date: 09/09/13



CHEMICAL WASTE MANAGEMENT OF THE NW

17629 Cedar Springs Lane
Arlington, OR 97812
(541) 454-2643
(541) 454-3279 Fax

PORT OF TACOMA
WAD001882984
3400 TAYLOR WAY
TACOMA WA 98421

CERTIFICATE OF DISPOSAL

Chemical Waste Management of the Northwest, Inc., ORD089452353, has received the following waste material:

GENERATOR:	PORT OF TACOMA
MANIFEST #:	011880637JJK
CWM TRACKING ID:	42756501
PROFILE #:	OR321468
LINE ITEM:	9b.1
QUANTITY:	1 DT
RECEIVED DATE:	08/28/13
DISPOSAL PROCESS(ES):	LANDFILL
FINAL DISPOSAL LOCATION:	LANDFILL 13
DISPOSAL DATE:	08/28/13

I certify, on behalf of the above listed treatment facility, that to the best of my knowledge, the above-described waste material was managed in compliance with all applicable laws, regulations, permits and licenses on the date listed above.

Robbi Jo Galvin

CWMNW RECORDS DEPARTMENT

Date: 09/05/13



CHEMICAL WASTE MANAGEMENT OF THE NW

17629 Cedar Springs Lane
Arlington, OR 97812
(541) 454-2643
(541) 454-3279 Fax

PORT OF TACOMA
WAD001882884
3400 TAYLOR WAY
TACOMA WA 98421

CERTIFICATE OF DISPOSAL

Chemical Waste Management of the Northwest, Inc., ORD089452353, has received the following waste material:

GENERATOR:	PORT OF TACOMA
MANIFEST #:	011880883JJK
CWM TRACKING ID:	42758401
PROFILE #:	OR321488
LINE ITEM:	9b.1
QUANTITY:	1 DT
RECEIVED DATE:	08/28/13
DISPOSAL PROCESS(ES):	LANDFILL
FINAL DISPOSAL LOCATION:	LANDFILL 13
DISPOSAL DATE:	08/28/13

I certify, on behalf of the above listed treatment facility, that to the best of my knowledge, the above-described waste material was managed in compliance with all applicable laws, regulations, permits and licenses on the date listed above.

Bobbi Jo Galvin

CWMNW RECORDS DEPARTMENT

Date: 09/09/13



CHEMICAL WASTE MANAGEMENT OF THE NW

17629 Cedar Springs Lane
Arlington, OR 97812
(541) 454-2643
(541) 454-3279 Fax

PORT OF TACOMA
WAD001882984
3400 TAYLOR WAY
TACOMA WA 98421

CERTIFICATE OF DISPOSAL

Chemical Waste Management of the Northwest, Inc., ORD089452353, has received the following waste material:

GENERATOR:	PORT OF TACOMA
MANIFEST #:	011880674JJK
CWM TRACKING ID:	42758501
PROFILE #:	OR321468
LINE ITEM:	9b.1
QUANTITY:	1 DT
RECEIVED DATE:	08/28/13
DISPOSAL PROCESS(ES):	LANDFILL
FINAL DISPOSAL LOCATION:	LANDFILL 13
DISPOSAL DATE:	08/28/13

I certify, on behalf of the above listed treatment facility, that to the best of my knowledge, the above-described waste material was managed in compliance with all applicable laws, regulations, permits and licenses on the date listed above.

Bobbi Jo Galvin

CWMNW RECORDS DEPARTMENT

Date:

09/09/13



CHEMICAL WASTE MANAGEMENT OF THE NW

17629 Cedar Springs Lane
Arlington, OR 97812
(541) 454-2643
(541) 454-3279 Fax

PORT OF TACOMA
WAD001882984
3400 TAYLOR WAY
TACOMA WA 98421

CERTIFICATE OF DISPOSAL

Chemical Waste Management of the Northwest, Inc., ORD089452353, has received the following waste material:

GENERATOR:	PORT OF TACOMA
MANIFEST #:	011880668JJK
CWM TRACKING ID:	42756601
PROFILE #:	OR321468
LINE ITEM:	9b.1
QUANTITY:	1 DT
RECEIVED DATE:	08/28/13
DISPOSAL PROCESS(ES):	LANDFILL
FINAL DISPOSAL LOCATION:	LANDFILL 13
DISPOSAL DATE:	08/28/13

I certify, on behalf of the above listed treatment facility, that to the best of my knowledge, the above-described waste material was managed in compliance with all applicable laws, regulations, permits and licenses on the date listed above.



CWMNW RECORDS DEPARTMENT

Date: 09/09/13



CHEMICAL WASTE MANAGEMENT OF THE NW

17629 Cedar Springs Lane
Arlington, OR 97812
(541) 454-2643
(541) 454-3279 Fax

PORT OF TACOMA
WAD001882984
3400 TAYLOR WAY
TACOMA WA 98421

CERTIFICATE OF DISPOSAL

Chemical Waste Management of the Northwest, Inc., ORD089452353, has received the following waste material:

GENERATOR:	PORT OF TACOMA
MANIFEST #:	011880678JJK
CWM TRACKING ID:	42757001
PROFILE #:	OR321468
LINE ITEM:	9b.1
QUANTITY:	1 DT
RECEIVED DATE:	08/28/13
DISPOSAL PROCESS(ES):	LANDFILL
FINAL DISPOSAL LOCATION:	LANDFILL 13
DISPOSAL DATE:	08/28/13

I certify, on behalf of the above listed treatment facility, that to the best of my knowledge, the above-described waste material was managed in compliance with all applicable laws, regulations, permits and licenses on the date listed above.

Bobbi Galvin

CWMNW RECORDS DEPARTMENT

Date: 09/09/13



CHEMICAL WASTE MANAGEMENT OF THE NW

17629 Cedar Springs Lane
Arlington, OR 97812
(541) 454-2643
(541) 454-3279 Fax

PORT OF TACOMA
WAD001882984
3400 TAYLOR WAY
TACOMA WA 98421

CERTIFICATE OF DISPOSAL

Chemical Waste Management of the Northwest, Inc., ORD089452353, has received the following waste material:

GENERATOR:	PORT OF TACOMA
MANIFEST #:	011880669JJK
CWM TRACKING ID:	42757101
PROFILE #:	OR321468
LINE ITEM:	9b.1
QUANTITY:	1 DT
RECEIVED DATE:	08/28/13
DISPOSAL PROCESS(ES):	LANDFILL
FINAL DISPOSAL LOCATION:	LANDFILL 13
DISPOSAL DATE:	08/28/13

I certify, on behalf of the above listed treatment facility, that to the best of my knowledge, the above-described waste material was managed in compliance with all applicable laws, regulations, permits and licenses on the date listed above.



CWMNW RECORDS DEPARTMENT

Date: 09/09/13



CHEMICAL WASTE MANAGEMENT OF THE NW

17629 Cedar Springs Lane
Arlington, OR 97812
(541) 454-2643
(541) 454-3279 Fax

PORT OF TACOMA
WAD001882984
3400 TAYLOR WAY
TACOMA WA 98421

CERTIFICATE OF DISPOSAL

Chemical Waste Management of the Northwest, Inc., ORD089452353, has received the following waste material:

GENERATOR:	PORT OF TACOMA
MANIFEST #:	011080681JJK
CWM TRACKING ID:	427527401
PROFILE #:	OR321468
LINE ITEM:	9b.1
QUANTITY:	1 DT
RECEIVED DATE:	08/28/13
DISPOSAL PROCESS(ES):	LANDFILL
FINAL DISPOSAL LOCATION:	LANDFILL 13
DISPOSAL DATE:	08/28/13

I certify, on behalf of the above listed treatment facility, that to the best of my knowledge, the above-described waste material was managed in compliance with all applicable laws, regulations, permits and licenses on the date listed above.



CWMNW RECORDS DEPARTMENT

Date: 09/09/13



CHEMICAL WASTE MANAGEMENT OF THE NW

17629 Cedar Springs Lane
Arlington, OR 97812
(541) 454-2643
(541) 454-3279 Fax

PORT OF TACOMA
WAD001882984
3400 TAYLOR WAY
TACOMA WA 98421

CERTIFICATE OF DISPOSAL

Chemical Waste Management of the Northwest, Inc., ORD089452353, has received the following waste material:

GENERATOR:	PORT OF TACOMA
MANIFEST #:	011880684JJK
CWM TRACKING ID:	452757601
PROFILE #:	OR321468
LINE ITEM:	9b.1
QUANTITY:	1 DT
RECEIVED DATE:	08/28/13
DISPOSAL PROCESS(ES):	LANDFILL
FINAL DISPOSAL LOCATION:	LANDFILL 13
DISPOSAL DATE:	08/28/13

I certify, on behalf of the above listed treatment facility, that to the best of my knowledge, the above-described waste material was managed in compliance with all applicable laws, regulations, permits and licenses on the date listed above.



CWMNW RECORDS DEPARTMENT

Date: 09/09/13



CHEMICAL WASTE MANAGEMENT OF THE NW
17629 Cedar Springs Lane
Arlington, OR 97812
(541) 454-2643
(541) 454-3279 Fax

PORT OF TACOMA
WAD001882984
3400 TAYLOR WAY
TACOMA WA 98421

CERTIFICATE OF DISPOSAL

Chemical Waste Management of the Northwest, Inc., ORD089452353, has received the following waste material:

GENERATOR:	PORT OF TACOMA
MANIFEST #:	010585291JJK
CWM TRACKING ID:	42760901
PROFILE #:	OR321468
LINE ITEM:	9b.1
QUANTITY:	1 DT
RECEIVED DATE:	08/29/13
DISPOSAL PROCESS(ES):	LANDFILL
FINAL DISPOSAL LOCATION:	LANDFILL 13
DISPOSAL DATE:	08/29/13

I certify, on behalf of the above listed treatment facility, that to the best of my knowledge, the above-described waste material was managed in compliance with all applicable laws, regulations, permits and licenses on the date listed above.



CWMNW RECORDS DEPARTMENT

Date: 09/12/13



CHEMICAL WASTE MANAGEMENT OF THE NW

17629 Cedar Springs Lane
Arlington, OR 97812
(541) 454-2643
(541) 454-3279 Fax

PORT OF TACOMA
WAD001882984
3400 TAYLOR WAY
TACOMA WA 98421

CERTIFICATE OF DISPOSAL

Chemical Waste Management of the Northwest, Inc., ORD089452353, has received the following waste material:

GENERATOR:	PORT OF TACOMA
MANIFEST #:	010585294JJK
CWM TRACKING ID:	42762801
PROFILE #:	OR321468
LINE ITEM:	9b.1
QUANTITY:	1 DT
RECEIVED DATE:	08/29/13
DISPOSAL PROCESS(ES):	LANDFILL
FINAL DISPOSAL LOCATION:	LANDFILL 13
DISPOSAL DATE:	08/29/13

I certify, on behalf of the above listed treatment facility, that to the best of my knowledge, the above-described waste material was managed in compliance with all applicable laws, regulations, permits and licenses on the date listed above.

Bobbi Jo Galvin

CWMNW RECORDS DEPARTMENT

Date: 09/12/13



CHEMICAL WASTE MANAGEMENT OF THE NW

17629 Cedar Springs Lane
Arlington, OR 97812
(541) 454-2643
(541) 454-3279 Fax

PORT OF TACOMA
WAD001882984
3400 TAYLOR WAY
TACOMA WA 98421

CERTIFICATE OF DISPOSAL

Chemical Waste Management of the Northwest, Inc., ORD089452353, has received the following waste material:

GENERATOR:	PORT OF TACOMA
MANIFEST #:	010585288JJK
CWM TRACKING ID:	42761201
PROFILE #:	OR321468
LINE ITEM:	9b.1
QUANTITY:	1 DT
RECEIVED DATE:	08/23/13
DISPOSAL PROCESS(ES):	LANDFILL
FINAL DISPOSAL LOCATION:	LANDFILL 13
DISPOSAL DATE:	08/29/13

I certify, on behalf of the above listed treatment facility, that to the best of my knowledge, the above-described waste material was managed in compliance with all applicable laws, regulations, permits and licenses on the date listed above.



CWMNW RECORDS DEPARTMENT

Date: 09/10/13



CHEMICAL WASTE MANAGEMENT OF THE NW

17629 Cedar Springs Lane
Arlington, OR 97812
(541) 454-2643
(541) 454-3279 Fax

PORT OF TACOMA
WAD001882984
3400 TAYLOR WAY
TACOMA WA 98421

CERTIFICATE OF DISPOSAL

Chemical Waste Management of the Northwest, Inc., ORD089452353, has received the following waste material:

GENERATOR:	PORT OF TACOMA
MANIFEST #:	010585286JJK
CWM TRACKING ID:	42761701
PROFILE #:	OR321468
LINE ITEM:	9b.1
QUANTITY:	1 DT
RECEIVED DATE:	08/29/13
DISPOSAL PROCESS(ES):	LANDFILL
FINAL DISPOSAL LOCATION:	LANDFILL 13
DISPOSAL DATE:	08/29/13

I certify, on behalf of the above listed treatment facility, that to the best of my knowledge, the above-described waste material was managed in compliance with all applicable laws, regulations, permits and licenses on the date listed above.



CWMNW RECORDS DEPARTMENT

Date: 09/10/13



CHEMICAL WASTE MANAGEMENT OF THE NW
17629 Cedar Springs Lane
Arlington, OR 97812
(541) 454-2643
(541) 454-3279 Fax

PORT OF TACOMA
WAD001882984
3400 TAYLOR WAY
TACOMA WA 98421

CERTIFICATE OF DISPOSAL

Chemical Waste Management of the Northwest, Inc., ORD089452353, has received the following waste material:

GENERATOR:	PORT OF TACOMA
MANIFEST #:	010585296JJK
CWM TRACKING ID:	42761801
PROFILE #:	OR321468
LINE ITEM:	9b.1
QUANTITY:	1 DT
RECEIVED DATE:	08/29/13
DISPOSAL PROCESS(ES):	LANDFILL
FINAL DISPOSAL LOCATION:	LANDFILL 13
DISPOSAL DATE:	08/29/13

I certify, on behalf of the above listed treatment facility, that to the best of my knowledge, the above-described waste material was managed in compliance with all applicable laws, regulations, permits and licenses on the date listed above.

Robbin Galvan

CWMNW RECORDS DEPARTMENT

Date: 09/10/13



CHEMICAL WASTE MANAGEMENT OF THE NW

17629 Cedar Springs Lane
Arlington, OR 97812
(541) 454-2643
(541) 454-3279 Fax

PORT OF TACOMA
WAD001882984
3400 TAYLOR WAY
TACOMA WA 98421

CERTIFICATE OF DISPOSAL

Chemical Waste Management of the Northwest, Inc., ORD089452353, has received the following waste material:

GENERATOR:	PORT OF TACOMA
MANIFEST #:	010585289JJK
CWM TRACKING ID:	42762001
PROFILE #:	OR321468
LINE ITEM:	9b.1
QUANTITY:	1 DT
RECEIVED DATE:	08/29/13
DISPOSAL PROCESS(ES):	LANDFILL
FINAL DISPOSAL LOCATION:	LANDFILL 13
DISPOSAL DATE:	08/29/13

I certify, on behalf of the above listed treatment facility, that to the best of my knowledge, the above-described waste material was managed in compliance with all applicable laws, regulations, permits and licenses on the date listed above.



CWMNW RECORDS DEPARTMENT

Date: 09/10/13



CHEMICAL WASTE MANAGEMENT OF THE NW
17629 Cedar Springs Lane
Arlington, OR 97812
(541) 454-2643
(541) 454-3279 Fax

PORT OF TACOMA
WAD001882984
3400 TAYLOR WAY
TACOMA WA 98421

CERTIFICATE OF DISPOSAL

Chemical Waste Management of the Northwest, Inc., ORD089452353, has received the following waste material:

GENERATOR:	PORT OF TACOMA
MANIFEST #:	010585295JJK
CWM TRACKING ID:	42762101
PROFILE #:	OR?21468
LINE ITEM:	9b.1
QUANTITY:	1 DT
RECEIVED DATE:	08/29/13
DISPOSAL PROCESS(ES):	LANDFILL
FINAL DISPOSAL LOCATION:	LANDFILL 13
DISPOSAL DATE:	08/29/13

I certify, on behalf of the above listed treatment facility, that to the best of my knowledge, the above-described waste material was managed in compliance with all applicable laws, regulations, permits and licenses on the date listed above.

Robbich Bohlin

CWMNW RECORDS DEPARTMENT

Date: 09/10/13



CHEMICAL WASTE MANAGEMENT OF THE NW

17629 Cedar Springs Lane
Arlington, OR 97812
(541) 454-2643
(541) 454-3279 Fax

PORT OF TACOMA
WAD001882984
3400 TAYLOR WAY
TACOMA WA 98421

CERTIFICATE OF DISPOSAL

Chemical Waste Management of the Northwest, Inc., ORD089452353, has received the following waste material:

GENERATOR:	PORT OF TACOMA
MANIFEST #:	010585293JJK
CWM TRACKING ID:	42762401
PROFILE #:	OR321468
LINE ITEM:	9b.1
QUANTITY:	1 DT
RECEIVED DATE:	08/29/13
DISPOSAL PROCESS(ES):	LANDFILL
FINAL DISPOSAL LOCATION:	LANDFILL 13
DISPOSAL DATE:	08/29/13

I certify, on behalf of the above listed treatment facility, that to the best of my knowledge, the above-described waste material was managed in compliance with all applicable laws, regulations, permits and licenses on the date listed above.



CWMNW RECORDS DEPARTMENT

Date: 09/10/13



CHEMICAL WASTE MANAGEMENT OF THE NW

17629 Cedar Springs Lane
Arlington, OR 97812
(541) 454-2643
(541) 454-3279 Fax

PORT OF TACOMA
WAD001882984
3400 TAYLOR WAY
TACOMA WA 98421

CERTIFICATE OF DISPOSAL

Chemical Waste Management of the Northwest, Inc., ORD089452353, has received the following waste material:

GENERATOR:	PORT OF TACOMA
MANIFEST #:	010585301JJK
CWM TRACKING ID:	42762501
PROFILE #:	OR321468
LINE ITEM:	9b.1
QUANTITY:	1 DT
RECEIVED DATE:	08/29/13
DISPOSAL PROCESS(ES):	LANDFILL
FINAL DISPOSAL LOCATION:	LANDFILL 13
DISPOSAL DATE:	08/29/13

I certify, on behalf of the above listed treatment facility, that to the best of my knowledge, the above-described waste material was managed in compliance with all applicable laws, regulations, permits and licenses on the date listed above.



CWMNW RECORDS DEPARTMENT

Date: 09/10/13





CHEMICAL WASTE MANAGEMENT OF THE NW
17629 Cedar Springs Lane
Arlington, OR 97812
(541) 454-2643
(541) 454-3279 Fax

PORT OF TACOMA
WAD001882984
3400 TAYLOR WAY
TACOMA WA 98421

RECEIVED
SEP 23 2013
ENGINEERING DEPT.

CERTIFICATE OF DISPOSAL

Chemical Waste Management of the Northwest, Inc., ORD089452353, has received the following waste material:

GENERATOR:	PORT OF TACOMA
MANIFEST #:	011880553JJK
CWM TRACKING ID:	42762701
PROFILE #:	OR321468
LINE ITEM:	9b.1
QUANTITY:	1 DT
RECEIVED DATE:	08/29/13
DISPOSAL PROCESS(ES):	LANDFILL
FINAL DISPOSAL LOCATION:	LANDFILL 13
DISPOSAL DATE:	08/29/13

I certify, on behalf of the above listed treatment facility, that to the best of my knowledge, the above-described waste material was managed in compliance with all applicable laws, regulations, permits and licenses on the date listed above.

Robbi J Galvin

CWMNW RECORDS DEPARTMENT

Date: 09/10/13



CHEMICAL WASTE MANAGEMENT OF THE NW

17629 Cedar Springs Lane
Arlington, OR 97812
(541) 454-2643
(541) 454-3279 Fax

PORT OF TACOMA
WAD001882984
3400 TAYLOR WAY
TACOMA WA 98421

CERTIFICATE OF DISPOSAL

Chemical Waste Management of the Northwest, Inc., ORD089452353, has received the following waste material:

GENERATOR:	PORT OF TACOMA
MANIFEST #:	010585300JJK
CWM TRACKING ID:	42762901
PROFILE #:	OR321468
LINE ITEM:	9b.1
QUANTITY:	1 DT
RECEIVED DATE:	08/29/13
DISPOSAL PROCESS(ES):	LANDFILL
FINAL DISPOSAL LOCATION:	LANDFILL 13
DISPOSAL DATE:	08/29/13

I certify, on behalf of the above listed treatment facility, that to the best of my knowledge, the above-described waste material was managed in compliance with all applicable laws, regulations, permits and licenses on the date listed above.



CWMNW RECORDS DEPARTMENT

Date: 09/10/13



CHEMICAL WASTE MANAGEMENT OF THE NW

17629 Cedar Springs Lane
Arlington, OR 97812
(541) 454-2643
(541) 454-3279 Fax

PORT OF TACOMA
WAD001882984
3400 TAYLOR WAY
TACOMA WA 98421

CERTIFICATE OF DISPOSAL

Chemical Waste Management of the Northwest, Inc., ORD089452353, has received the following waste material:

GENERATOR:	PORT OF TACOMA
MANIFEST #:	010585299JJK
CWM TRACKING ID:	42763001
PROFILE #:	OR321468
LINE ITEM:	9b.1
QUANTITY:	1 DT
RECEIVED DATE:	08/29/13
DISPOSAL PROCESS(ES):	LANDFILL
FINAL DISPOSAL LOCATION:	LANDFILL 13
DISPOSAL DATE:	08/29/13

I certify, on behalf of the above listed treatment facility, that to the best of my knowledge, the above-described waste material was managed in compliance with all applicable laws, regulations, permits and licenses on the date listed above.

Robbi Jo Galvin

CWMNW RECORDS DEPARTMENT

Date: 09/10/13



CHEMICAL WASTE MANAGEMENT OF THE NW

17629 Cedar Springs Lane
Arlington, OR 97812
(541) 454-2643
(541) 454-3279 Fax

PORT OF TACOMA
WAD001882984
3400 TAYLOR WAY
TACOMA WA 98421

CERTIFICATE OF DISPOSAL

Chemical Waste Management of the Northwest, Inc., ORD089452353, has received the following waste material:

GENERATOR:	PORT OF TACOMA
MANIFEST #:	010585297JJK
CWM TRACKING ID:	42763201
PROFILE #:	OR321468
LINE ITEM:	9b.1
QUANTITY:	1 DT
RECEIVED DATE:	08/29/13
DISPOSAL PROCESS(ES):	LANDFILL
FINAL DISPOSAL LOCATION:	LANDFILL 13
DISPOSAL DATE:	08/29/13

I certify, on behalf of the above listed treatment facility, that to the best of my knowledge, the above-described waste material was managed in compliance with all applicable laws, regulations, permits and licenses on the date listed above.

Bobbi Jo Galwin

CWMNW RECORDS DEPARTMENT

Date: 09/10/13



CHEMICAL WASTE MANAGEMENT OF THE NW

17629 Cedar Springs Lane
Arlington, OR 97812
(541) 454-2643
(541) 454-3279 Fax

PORT OF TACOMA
WAD001882984
3400 TAYLOR WAY
TACOMA WA 98421

CERTIFICATE OF DISPOSAL

Chemical Waste Management of the Northwest, Inc., ORD089452353, has received the following waste material:

GENERATOR:	PORT OF TACOMA
MANIFEST #:	010585298JJK
CWM TRACKING ID:	42763301
PROFILE #:	OR321468
LINE ITEM:	9b.1
QUANTITY:	1 DT
RECEIVED DATE:	08/29/13
DISPOSAL PROCESS(ES):	LANDFILL
FINAL DISPOSAL LOCATION:	LANDFILL 13
DISPOSAL DATE:	08/29/13

I certify, on behalf of the above listed treatment facility, that to the best of my knowledge, the above-described waste material was managed in compliance with all applicable laws, regulations, permits and licenses on the date listed above.

Robbie J Galvin

CWMNW RECORDS DEPARTMENT

Date: 09/10/13



CHEMICAL WASTE MANAGEMENT OF THE NW

17629 Cedar Springs Lane
Arlington, OR 97812
(541) 454-2643
(541) 454-3279 Fax

PORT OF TACOMA
WAD001882984
3400 TAYLOR WAY
TACOMA WA 98421

CERTIFICATE OF DISPOSAL

Chemical Waste Management of the Northwest, Inc., ORD089452353, has received the following waste material:

GENERATOR:	PORT OF TACOMA
MANIFEST #:	010585292JJK
CWM TRACKING ID:	42763401
PROFILE #:	OR321468
LINE ITEM:	9b.1
QUANTITY:	1 DT
RECEIVED DATE:	08/29/13
DISPOSAL PROCESS(ES):	LANDFILL
FINAL DISPOSAL LOCATION:	LANDFILL 13
DISPOSAL DATE:	08/29/13

I certify, on behalf of the above listed treatment facility, that to the best of my knowledge, the above-described waste material was managed in compliance with all applicable laws, regulations, permits and licenses on the date listed above.

Robbilo Galvin

CWMNW RECORDS DEPARTMENT

Date: 09/10/13



CHEMICAL WASTE MANAGEMENT OF THE NW

17629 Cedar Springs Lane
Arlington, OR 97812
(541) 454-2643
(541) 454-3279 Fax

PORT OF TACOMA
WAD001882984
3400 TAYLOR WAY
TACOMA WA 98421

CERTIFICATE OF DISPOSAL

Chemical Waste Management of the Northwest, Inc., ORD089452353, has received the following waste material:

GENERATOR:	PORT OF TACOMA
MANIFEST #:	010585290JJK
CWM TRACKING ID:	42703701
PROFILE #:	OR321468
LINE ITEM:	9b.1
QUANTITY:	1 DT
RECEIVED DATE:	08/29/13
DISPOSAL PROCESS(ES):	LANDFILL
FINAL DISPOSAL LOCATION:	LANDFILL 13
DISPOSAL DATE:	08/29/13

I certify, on behalf of the above listed treatment facility, that to the best of my knowledge, the above-described waste material was managed in compliance with all applicable laws, regulations, permits and licenses on the date listed above.

Robbilo Galvin

CWMNW RECORDS DEPARTMENT

Date: 09/10/13



CHEMICAL WASTE MANAGEMENT OF THE NW
17629 Cedar Springs Lane
Arlington, OR 97812
(541) 454-2643
(541) 454-3279 Fax

PORT OF TACOMA
WAD001882984
3400 TAYLOR WAY
TACOMA WA 98421

CERTIFICATE OF DISPOSAL

Chemical Waste Management of the Northwest, Inc., ORD089452353, has received the following waste material:

GENERATOR:	PORT OF TACOMA
MANIFEST #:	010585305JJK
CWM TRACKING ID:	42764601
PROFILE #:	OR321468
LINE ITEM:	9b.1
QUANTITY:	1 DT
RECEIVED DATE:	08/29/13
DISPOSAL PROCESS(ES):	LANDFILL
FINAL DISPOSAL LOCATION:	LANDFILL 13
DISPOSAL DATE:	08/29/13

I certify, on behalf of the above listed treatment facility, that to the best of my knowledge, the above-described waste material was managed in compliance with all applicable laws, regulations, permits and licenses on the date listed above.

Roberto Galvin

CWMNW RECORDS DEPARTMENT

Date: 09/10/13



CHEMICAL WASTE MANAGEMENT OF THE NW

17629 Cedar Springs Lane
Arlington, OR 97812
(541) 454-2643
(541) 454-3279 Fax

PORT OF TACOMA
WAD001882984
3400 TAYLOR WAY
TACOMA WA 98421

CERTIFICATE OF DISPOSAL

Chemical Waste Management of the Northwest, Inc., ORD089452353, has received the following waste material:

GENERATOR:	POFT OF TACOMA
MANIFEST #:	010585304JJK
CWM TRACKING ID:	42764701
PROFILE #:	OR321468
LINE ITEM:	9b.1
QUANTITY:	1 DT
RECEIVED DATE:	08/29/13
DISPOSAL PROCESS(ES):	LANDFILL
FINAL DISPOSAL LOCATION:	LANDFILL 13
DISPOSAL DATE:	08/29/13

I certify, on behalf of the above listed treatment facility, that to the best of my knowledge, the above-described waste material was managed in compliance with all applicable laws, regulations, permits and licenses on the date listed above.

Bobbi Jo Galvin

CWMNW RECORDS DEPARTMENT

Date: 09/10/13



CHEMICAL WASTE MANAGEMENT OF THE NW

17629 Cedar Springs Lane
Arlington, OR 97812
(541) 454-2643
(541) 454-3279 Fax

PORT OF TACOMA
WAD001882984
3400 TAYLOR WAY
TACOMA WA 98421

CERTIFICATE OF DISPOSAL

Chemical Waste Management of the Northwest, Inc., ORD089452353, has received the following waste material:

GENERATOR:	PORT OF TACOMA
MANIFEST #:	010585302JJK
CWM TRACKING ID:	42765001
PROFILE #:	OR321468
LINE ITEM:	9b.1
QUANTITY:	1 DT
RECEIVED DATE:	08/29/13
DISPOSAL PROCESS(ES):	LANDFILL
FINAL DISPOSAL LOCATION:	LANDFILL 13
DISPOSAL DATE:	08/29/13

I certify, on behalf of the above listed treatment facility, that to the best of my knowledge, the above-described waste material was managed in compliance with all applicable laws, regulations, permits and licenses on the date listed above.

Robbi Jobalvin

CWMNW RECORDS DEPARTMENT

Date: 09/10/13



CHEMICAL WASTE MANAGEMENT OF THE NW

17629 Cedar Springs Lane
Arlington, OR 97812
(541) 454-2643
(541) 454-3279 Fax

PORT OF TACOMA
WAD001882984
3400 TAYLOR WAY
TACOMA WA 98421

CERTIFICATE OF DISPOSAL

Chemical Waste Management of the Northwest, Inc., ORD089452353, has received the following waste material:

GENERATOR:	PORT OF TACOMA
MANIFEST #:	010585303JJK
CWM TRACKING ID:	42765201
PROFILE #:	OR321468
LINE ITEM:	9b.1
QUANTITY:	1 DT
RECEIVED DATE:	08/29/13
DISPOSAL PROCESS(ES):	LANDFILL
FINAL DISPOSAL LOCATION:	LANDFILL 13
DISPOSAL DATE:	08/29/13

I certify, on behalf of the above listed treatment facility, that to the best of my knowledge, the above-described waste material was managed in compliance with all applicable laws, regulations, permits and licenses on the date listed above.



CWMNW RECORDS DEPARTMENT

Date: 09/10/13



CHEMICAL WASTE MANAGEMENT OF THE NW

17629 Cedar Springs Lane
Arlington, OR 97812
(541) 454-2643
(541) 454-3279 Fax

PORT OF TACOMA
WAD001882984
3400 TAYLOR WAY
TACOMA WA 98421

CERTIFICATE OF DISPOSAL

Chemical Waste Management of the Northwest, Inc., ORD089452353, has received the following waste material:

GENERATOR:	PORT OF TACOMA
MANIFEST #:	011880533JJK
CWM TRACKING ID:	42765601
PROFILE #:	OR321468
LINE ITEM:	9b.1
QUANTITY:	1 DT
RECEIVED DATE:	08/29/13
DISPOSAL PROCESS(ES):	LANDFILL
FINAL DISPOSAL LOCATION:	LANDFILL 13
DISPOSAL DATE:	08/29/13

I certify, on behalf of the above listed treatment facility, that to the best of my knowledge, the above-described waste material was managed in compliance with all applicable laws, regulations, permits and licenses on the date listed above.

Bobbi Jo Galvin

CWMNW RECORDS DEPARTMENT

Date: 09/10/13



CHEMICAL WASTE MANAGEMENT OF THE NW

17629 Cedar Springs Lane
Arlington, OR 97812
(541) 454-2643
(541) 454-3279 Fax

PORT OF TACOMA
WAD001882984
3400 TAYLOR WAY
TACOMA WA 98421

CERTIFICATE OF DISPOSAL

Chemical Waste Management of the Northwest, Inc., ORD089452353, has received the following waste material:

GENERATOR: PORT OF TACOMA
MANIFEST #: 011880527JJK
CWM TRACKING ID: 42765701
PROFILE #: OR321468
LINE ITEM: 9b.1
QUANTITY: 1 DT
RECEIVED DATE: 08/29/13

DISPOSAL PROCESS(ES): LANDFILL
FINAL DISPOSAL LOCATION: LANDFILL 13
DISPOSAL DATE: 08/29/13

I certify, on behalf of the above listed treatment facility, that to the best of my knowledge, the above-described waste material was managed in compliance with all applicable laws, regulations, permits and licenses on the date listed above.

Robbie Galvin

CWMNW RECORDS DEPARTMENT

Date: 09/10/13



CHEMICAL WASTE MANAGEMENT OF THE NV

17629 Cedar Springs Lane
Arlington, OR 97812
(541) 454-2643
(541) 454-3279 Fax

PORT OF TACOMA
WAD001882984
3400 TAYLOR WAY
TACOMA WA 98421

CERTIFICATE OF DISPOSAL

Chemical Waste Management of the Northwest, Inc., ORD089452353, has received the following waste material:

GENERATOR:	PORT OF TACOMA
MANIFEST #:	011880532JJK
CWM TRACKING ID:	42765801
PROFILE #:	OR321468
LINE ITEM:	9b.1
QUANTITY:	1 DT
RECEIVED DATE:	08/29/13
DISPOSAL PROCESS(ES):	LANDFILL
FINAL DISPOSAL LOCATION:	LANDFILL 13
DISPOSAL DATE:	08/29/13

I certify, on behalf of the above listed treatment facility, that to the best of my knowledge, the above-described waste material was managed in compliance with all applicable laws, regulations, permits and licenses on the date listed above.

Bobbi Galvin _____

CWMNW RECORDS DEPARTMENT
Date: 09/10/13



CHEMICAL WASTE MANAGEMENT OF THE NW

17629 Cedar Springs Lane
Arlington, OR 97812
(541) 454-2643
(541) 454-3279 Fax

PORT OF TACOMA
WAD001882984
3400 TAYLOR WAY
TACOMA WA 98421

CERTIFICATE OF DISPOSAL

Chemical Waste Management of the Northwest, Inc., ORD089452353, has received the following waste material:

GENERATOR:	PORT OF TACOMA
MANIFEST #:	011880644JJK
CWM TRACKING ID:	42766301
PROFILE #:	OR321468
LINE ITEM:	9b.1
QUANTITY:	1 DT
RECEIVED DATE:	08/29/13
DISPOSAL PROCESS(ES):	LANDFILL
FINAL DISPOSAL LOCATION:	LANDFILL 13
DISPOSAL DATE:	08/29/13

I certify, on behalf of the above listed treatment facility, that to the best of my knowledge, the above-described waste material was managed in compliance with all applicable laws, regulations, permits and licenses on the date listed above.



CWMNW RECORDS DEPARTMENT

Date: 09/10/13



CHEMICAL WASTE MANAGEMENT OF THE NW

17629 Cedar Springs Lane
Arlington, OR 97812
(541) 454-2643
(541) 454-3279 Fax

PORT OF TACOMA
WAD001882984
3400 TAYLOR WAY
TACOMA WA 98421

CERTIFICATE OF DISPOSAL

Chemical Waste Management of the Northwest, Inc., ORD089452353, has received the following waste material:

GENERATOR:	PORT OF TACOMA
MANIFEST #:	011880584JJK
CWM TRACKING ID:	42766501
PROFILE #:	OR321468
LINE ITEM:	9b.1
QUANTITY:	1 DT
RECEIVED DATE:	08/29/13
DISPOSAL PROCESS(ES):	LANDFILL
FINAL DISPOSAL LOCATION:	LANDFILL 13
DISPOSAL DATE:	08/29/13

I certify, on behalf of the above listed treatment facility, that to the best of my knowledge, the above-described waste material was managed in compliance with all applicable laws, regulations, permits and licenses on the date listed above.

Robbi Jo Galvin

CWMNW RECORDS DEPARTMENT

Date: 09/10/13



CHEMICAL WASTE MANAGEMENT OF THE NW

17629 Cedar Springs Lane
Arlington, OR 97812
(541) 454-2643
(541) 454-3279 Fax

PORT OF TACOMA
WAD001882984
3400 TAYLOR WAY
TACOMA WA 98421

CERTIFICATE OF DISPOSAL

Chemical Waste Management of the Northwest, Inc., ORD089452353, has received the following waste material:

GENERATOR:	PORT OF TACOMA
MANIFEST #:	011880645JJK
CWM TRACKING ID:	42766601
PROFILE #:	OR321468
LINE ITEM:	9b.1
QUANTITY:	1 DT
RECEIVED DATE:	08/29/13
DISPOSAL PROCESS(ES):	LANDFILL
FINAL DISPOSAL LOCATION:	LANDFILL 13
DISPOSAL DATE:	08/29/13

I certify, on behalf of the above listed treatment facility, that to the best of my knowledge, the above-described waste material was managed in compliance with all applicable laws, regulations, permits and licenses on the date listed above.

Bobbi Jo Galvin

CWMNW RECORDS DEPARTMENT

Date: 09/10/13



CHEMICAL WASTE MANAGEMENT OF THE NW

17629 Cedar Springs Lane
Arlington, OR 97812
(541) 454-2643
(541) 454-3279 Fax

PORT OF TACOMA
WAD001882984
3400 TAYLOR WAY
TACOMA WA 98421

CERTIFICATE OF DISPOSAL

Chemical Waste Management of the Northwest, Inc., ORD089452353, has received the following waste material:

GENERATOR:	PORT OF TACOMA
MANIFEST #:	011880590JJK
CWM TRACKING ID:	42766701
PROFILE #:	OR321468
LINE ITEM:	9b.1
QUANTITY:	1 DT
RECEIVED DATE:	08/29/13
DISPOSAL PROCESS(ES):	LANDFILL
FINAL DISPOSAL LOCATION:	LANDFILL 13
DISPOSAL DATE:	08/29/13

I certify, on behalf of the above listed treatment facility, that to the best of my knowledge, the above-described waste material was managed in compliance with all applicable laws, regulations, permits and licenses on the date listed above.

Bobbi Jo Galvin

CWMNW RECORDS DEPARTMENT

Date: 09/10/13



CHEMICAL WASTE MANAGEMENT OF THE NW

17629 Cedar Springs Lane
Arlington, OR 97812
(541) 454-2643
(541) 454-3279 Fax

PORT OF TACOMA
WAD001882984
3400 TAYLOR WAY
TACOMA WA 98421

CERTIFICATE OF DISPOSAL

Chemical Waste Management of the Northwest, Inc., ORD089452353, has received the following waste material:

GENERATOR:	PORT OF TACOMA
MANIFEST #:	011880561JJK
CWM TRACKING ID:	42766901
PROFILE #:	OR321468
LINE ITEM:	9b.1
QUANTITY:	1 DT
RECEIVED DATE:	08/29/13
DISPOSAL PROCESS(ES):	LANDFILL
FINAL DISPOSAL LOCATION:	LANDFILL 13
DISPOSAL DATE:	08/29/13

I certify, on behalf of the above listed treatment facility, that to the best of my knowledge, the above-described waste material was managed in compliance with all applicable laws, regulations, permits and licenses on the date listed above.

Bobbi Jo Galvin

CWMNW RECORDS DEPARTMENT

Date: 09/10/13



CHEMICAL WASTE MANAGEMENT OF THE NW

17629 Cedar Springs Lane
Arlington, OR 97812
(541) 454-2643
(541) 454-3279 Fax

PORT OF TACOMA
WAD001882984
3400 TAYLOR WAY
TACOMA WA 98421

CERTIFICATE OF DISPOSAL

Chemical Waste Management of the Northwest, Inc., ORD089452353, has received the following waste material:

GENERATOR:	PORT OF TACOMA
MANIFEST #:	011880643JJK
CWM TRACKING ID:	42767001
PROFILE #:	OR321468
LINE ITEM:	9b.1
QUANTITY:	1 DT
RECEIVED DATE:	08/29/13
DISPOSAL PROCESS(ES):	LANDFILL
FINAL DISPOSAL LOCATION:	LANDFILL 13
DISPOSAL DATE:	08/29/13

I certify, on behalf of the above listed treatment facility, that to the best of my knowledge, the above-described waste material was managed in compliance with all applicable laws, regulations, permits and licenses on the date listed above.

Bobbi Jo Galvin

CWMNW RECORDS DEPARTMENT

Date: 09/10/13



CHEMICAL WASTE MANAGEMENT OF THE NW

17629 Cedar Springs Lane
Arlington, OR 97812
(541) 454-2643
(541) 454-3279 Fax

PORT OF TACOMA
WAD001882984
3400 TAYLOR WAY
TACOMA WA 98421

CERTIFICATE OF DISPOSAL

Chemical Waste Management of the Northwest, Inc., ORD089452353, has received the following waste material:

GENERATOR:	PORT OF TACOMA
MANIFEST #:	011880649JJK
CWM TRACKING ID:	42767101
PROFILE #:	OR321468
LINE ITEM:	9b.1
QUANTITY:	1 DT
RECEIVED DATE:	08/29/13
DISPOSAL PROCESS(ES):	LANDFILL
FINAL DISPOSAL LOCATION:	LANDFILL 13
DISPOSAL DATE:	08/29/13

I certify, on behalf of the above listed treatment facility, that to the best of my knowledge, the above-described waste material was managed in compliance with all applicable laws, regulations, permits and licenses on the date listed above.

Robb Galvin

CWMNW RECORDS DEPARTMENT

Date: 09/10/13



CHEMICAL WASTE MANAGEMENT OF THE NW

17629 Cedar Springs Lane
Arlington, OR 97812
(541) 454-2643
(541) 454-3279 Fax

PORT OF TACOMA
WAD001882984
3400 TAYLOR WAY
TACOMA WA 98421

CERTIFICATE OF DISPOSAL

Chemical Waste Management of the Northwest, Inc., ORD089452353, has received the following waste material:

GENERATOR:	PORT OF TACOMA
MANIFEST #:	010585287JJK
CWM TRACKING ID:	42761001
PROFILE #:	OR:21468
LINE ITEM:	9b.1
QUANTITY:	1 DT
RECEIVED DATE:	08/29/13
DISPOSAL PROCESS(ES):	LANDFILL
FINAL DISPOSAL LOCATION:	LANDFILL 13
DISPOSAL DATE:	08/29/13

I certify, on behalf of the above listed treatment facility, that to the best of my knowledge, the above-described waste material was managed in compliance with all applicable laws, regulations, permits and licenses on the date listed above.



CWMNW RECORDS DEPARTMENT
Date:

09/10/13



CHEMICAL WASTE MANAGEMENT OF THE NW

17629 Cedar Springs Lane
Arlington, OR 97812
(541) 454-2643
(541) 454-3279 Fax

PORT OF TACOMA
WAD001882984
3400 TAYLOR WAY
TACOMA WA 98421

CERTIFICATE OF DISPOSAL

Chemical Waste Management of the Northwest, Inc., ORD089452353, has received the following waste material:

GENERATOR:	PORT OF TACOMA
MANIFEST #:	011880687JJK
CWM TRACKING ID:	42759701
PROFILE #:	OR321468
LINE ITEM:	9b.1
QUANTITY:	1 DT
RECEIVED DATE:	08/29/13
DISPOSAL PROCESS(ES):	LANDFILL
FINAL DISPOSAL LOCATION:	LANDFILL 13
DISPOSAL DATE:	08/29/13

I certify, on behalf of the above listed treatment facility, that to the best of my knowledge, the above-described waste material was managed in compliance with all applicable laws, regulations, permits and licenses on the date listed above.

Bobbi Jo Galvin

CWMNW RECORDS DEPARTMENT

Date: 09/10/13



CHEMICAL WASTE MANAGEMENT OF THE NW

17629 Cedar Springs Lane
Arlington, OR 97812
(541) 454-2643
(541) 454-3279 Fax

PORT OF TACOMA
WAD001882984
3400 TAYLOR WAY
TACOMA WA 98421

CERTIFICATE OF DISPOSAL

Chemical Waste Management of the Northwest, Inc., ORD089452353, has received the following waste material:

GENERATOR: PORT OF TACOMA
MANIFEST #: 011880688JJK
CWM TRACKING ID: 42759801
PROFILE #: OR321468
LINE ITEM: 9b.1
QUANTITY: 1 DT
RECEIVED DATE: 08/29/13

DISPOSAL PROCESS(ES): LANDFILL
FINAL DISPOSAL LOCATION: LANDFILL 13
DISPOSAL DATE: 08/29/13

I certify, on behalf of the above listed treatment facility, that to the best of my knowledge, the above-described waste material was managed in compliance with all applicable laws, regulations, permits and licenses on the date listed above.

Bubbin Galvin

CWMNW RECORDS DEPARTMENT

Date: 09/10/13



CHEMICAL WASTE MANAGEMENT OF THE NW

17629 Cedar Springs Lane
Arlington, OR 97812
(541) 454-2643
(541) 454-3279 Fax

PORT OF TACOMA
WAD001882984
3400 TAYLOR WAY
TACOMA WA 98421

CERTIFICATE OF DISPOSAL

Chemical Waste Management of the Northwest, Inc., ORD089452353, has received the following waste material:

GENERATOR:	PORT OF TACOMA
MANIFEST #:	011880655JJK
CWM TRACKING ID:	42767201
PROFILE #:	OR321468
LINE ITEM:	9b.1
QUANTITY:	1 DT
RECEIVED DATE:	08/29/13
DISPOSAL PROCESS(ES):	LANDFILL
FINAL DISPOSAL LOCATION:	LANDFILL 13
DISPOSAL DATE:	08/29/13

I certify, on behalf of the above listed treatment facility, that to the best of my knowledge, the above-described waste material was managed in compliance with all applicable laws, regulations, permits and licenses on the date listed above.

Bobbi Jo Galvin

CWMNW RECORDS DEPARTMENT

Date: 09/10/13



CHEMICAL WASTE MANAGEMENT OF THE NW

17629 Cedar Springs Lane
Arlington, OR 97812
(541) 454-2643
(541) 454-3279 Fax

PORT OF TACOMA
WAD001882984
3400 TAYLOR WAY
TACOMA WA 98421

CERTIFICATE OF DISPOSAL

Chemical Waste Management of the Northwest, Inc., ORD089452353, has received the following waste material:

GENERATOR:	PORT OF TACOMA
MANIFEST #:	011880651JJK
CWM TRACKING ID:	42767301
PROFILE #:	OR321468
LINE ITEM:	9b.1
QUANTITY:	1 DT
RECEIVED DATE:	08/29/13
DISPOSAL PROCESS(ES):	LANDFILL
FINAL DISPOSAL LOCATION:	LANDFILL 13
DISPOSAL DATE:	08/29/13

I certify, on behalf of the above listed treatment facility, that to the best of my knowledge, the above-described waste material was managed in compliance with all applicable laws, regulations, permits and licenses on the date listed above.



CWMNW RECORDS DEPARTMENT

Date: 09/10/13



CHEMICAL WASTE MANAGEMENT OF THE NW

17629 Cedar Springs Lane
Arlington, OR 97812
(541) 454-2643
(541) 454-3279 Fax

PORT OF TACOMA
WAD001882984
3400 TAYLOR WAY
TACOMA WA 98421

CERTIFICATE OF DISPOSAL

Chemical Waste Management of the Northwest, Inc., ORD089452353, has received the following waste material:

GENERATOR:	PORT OF TACOMA
MANIFEST #:	01180654JJK
CWM TRACKING ID:	42767401
PROFILE #:	OR321468
LINE ITEM:	9b.1
QUANTITY:	1 DT
RECEIVED DATE:	08/29/13
DISPOSAL PROCESS(ES):	LANDFILL
FINAL DISPOSAL LOCATION:	LANDFILL 13
DISPOSAL DATE:	08/29/13

I certify, on behalf of the above listed treatment facility, that to the best of my knowledge, the above-described waste material was managed in compliance with all applicable laws, regulations, permits and licenses on the date listed above.

Bobbi J. Galvin

CWMNW RECORDS DEPARTMENT

Date: 09/10/13



CHEMICAL WASTE MANAGEMENT OF THE NW
17629 Cedar Springs Lane
Arlington, OR 97812
(541) 454-2643
(541) 454-3279 Fax

PORT OF TACOMA
WAD001882984
3400 TAYLOR WAY
TACOMA WA 98421

CERTIFICATE OF DISPOSAL

Chemical Waste Management of the Northwest, Inc., ORD089452353, has received the following waste material:

GENERATOR:	PORT OF TACOMA
MANIFEST #:	010585308JJK
CWM TRACKING ID:	42770701
PROFILE #:	OR321468
LINE ITEM:	9b.1
QUANTITY:	1 DT
RECEIVED DATE:	09/03/13
DISPOSAL PROCESS(ES):	LANDFILL
FINAL DISPOSAL LOCATION:	LANDFILL 13
DISPOSAL DATE:	09/03/13

I certify, on behalf of the above listed treatment facility, that to the best of my knowledge, the above-described waste material was managed in compliance with all applicable laws, regulations, permits and licenses on the date listed above.



CWMNW RECORDS DEPARTMENT

Date: 09/12/13



CHEMICAL WASTE MANAGEMENT OF THE NW
17629 Cedar Springs Lane
Arlington, OR 97812
(541) 454-2643
(541) 454-3279 Fax

PORT OF TACOMA
WAD001882984
3400 TAYLOR WAY
TACOMA WA 98421

CERTIFICATE OF DISPOSAL

Chemical Waste Management of the Northwest, Inc., ORD089452353, has received the following waste material:

GENERATOR:	PORT OF TACOMA
MANIFEST #:	010585312JJK
CWM TRACKING ID:	42770901
PROFILE #:	OR321468
LINE ITEM:	9b.1
QUANTITY:	1 DT
RECEIVED DATE:	09/03/13
DISPOSAL PROCESS(ES):	LANDFILL
FINAL DISPOSAL LOCATION:	LANDFILL 13
DISPOSAL DATE:	09/03/13

I certify, on behalf of the above listed treatment facility, that to the best of my knowledge, the above-described waste material was managed in compliance with all applicable laws, regulations, permits and licenses on the date listed above.



CWMNW RECORDS DEPARTMENT
Date: 09/12/13



CHEMICAL WASTE MANAGEMENT OF THE NW
17629 Cedar Springs Lane
Arlington, OR 97812
(541) 454-2643
(541) 454-3279 Fax

PORT OF TACOMA
WAD001882984
3400 TAYLOR WAY
TACOMA WA 98421

CERTIFICATE OF DISPOSAL

Chemical Waste Management of the Northwest, Inc., ORD089452353, has received the following waste material:

GENERATOR:	PORT OF TACOMA
MANIFEST #:	010585311JJK
CWM TRACKING ID:	42771001
PROFILE #:	OR321468
LINE ITEM:	9b.1
QUANTITY:	1 DT
RECEIVED DATE:	09/03/13
DISPOSAL PROCESS(ES):	LANDFILL
FINAL DISPOSAL LOCATION:	LANDFILL 13
DISPOSAL DATE:	09/03/13

I certify, on behalf of the above listed treatment facility, that to the best of my knowledge, the above-described waste material was managed in compliance with all applicable laws, regulations, permits and licenses on the date listed above.

Robbin Babin

CWMNW RECORDS DEPARTMENT

Date: 09/12/13



CHEMICAL WASTE MANAGEMENT OF THE NW

17629 Cedar Springs Lane
Arlington, OR 97812
(541) 454-2643
(541) 454-3279 Fax

PORT OF TACOMA
WAD001882984
3400 TAYLOR WAY
TACOMA WA 98421

CERTIFICATE OF DISPOSAL

Chemical Waste Management of the Northwest, Inc., ORD089452353, has received the following waste material:

GENERATOR:	PORT OF TACOMA
MANIFEST #:	010585306JJK
CWM TRACKING ID:	42771101
PROFILE #:	OR321468
LINE ITEM:	9b.1
QUANTITY:	1 DT
RECEIVED DATE:	09/03/13
DISPOSAL PROCESS(ES):	LANDFILL
FINAL DISPOSAL LOCATION:	LANDFILL 13
DISPOSAL DATE:	09/03/13

I certify, on behalf of the above listed treatment facility, that to the best of my knowledge, the above-described waste material was managed in compliance with all applicable laws, regulations, permits and licenses on the date listed above.

Bebbi Advin

CWMNW RECORDS DEPARTMENT

Date: 09/12/13



CHEMICAL WASTE MANAGEMENT OF THE NW
17629 Cedar Springs Lane
Arlington, OR 97812
(541) 454-2643
(541) 454-3279 Fax

PORT OF TACOMA
WAD001882984
3400 TAYLOR WAY
TACOMA WA 98421

CERTIFICATE OF DISPOSAL

Chemical Waste Management of the Northwest, Inc., ORD089452353, has received the following waste material:

GENERATOR:	PORT OF TACOMA
MANIFEST #:	010585313JJK
CWM TRACKING ID:	42771201
PROFILE #:	OR321468
LINE ITEM:	9b.1
QUANTITY:	1 DT
RECEIVED DATE:	09/03/13
DISPOSAL PROCESS(ES):	LANDFILL
FINAL DISPOSAL LOCATION:	LANDFILL 13
DISPOSAL DATE:	09/03/13

I certify, on behalf of the above listed treatment facility, that to the best of my knowledge, the above-described waste material was managed in compliance with all applicable laws, regulations, permits and licenses on the date listed above.



CWMNW RECORDS DEPARTMENT
Date: 09/12/13



CHEMICAL WASTE MANAGEMENT OF THE NW
17629 Cedar Springs Lane
Arlington, OR 97812
(541) 454-2643
(541) 454-3279 Fax

PORT OF TACOMA
WAD001882984
3400 TAYLOR WAY
TACOMA WA 98421

CERTIFICATE OF DISPOSAL

Chemical Waste Management of the Northwest, Inc., ORD089452353, has received the following waste material:

GENERATOR:	PORT OF TACOMA
MANIFEST #:	010585310JJK
CWM TRACKING ID:	42771301
PROFILE #:	OR321468
LINE ITEM:	9b.1
QUANTITY:	1 DT
RECEIVED DATE:	09/03/13
DISPOSAL PROCESS(ES):	LANDFILL
FINAL DISPOSAL LOCATION:	LANDFILL 13
DISPOSAL DATE:	09/03/13

I certify, on behalf of the above listed treatment facility, that to the best of my knowledge, the above-described waste material was managed in compliance with all applicable laws, regulations, permits and licenses on the date listed above.

Bobbi Jobalvin

CWMNW RECORDS DEPARTMENT
Date: 09/12/13



CHEMICAL WASTE MANAGEMENT OF THE NW
17629 Cedar Springs Lane
Arlington, OR 97812
(541) 454-2643
(541) 454-3279 Fax

PORT OF TACOMA
WAD001882984
3400 TAYLOR WAY
TACOMA WA 98421

CERTIFICATE OF DISPOSAL

Chemical Waste Management of the Northwest, Inc., ORD089452353, has received the following waste material:

GENERATOR:	PORT OF TACOMA
MANIFEST #:	010585307JJK
CWM TRACKING ID:	42769101
PROFILE #:	OR321468
LINE ITEM:	9b.1
QUANTITY:	1 DT
RECEIVED DATE:	09/03/13
DISPOSAL PROCESS(ES):	LANDFILL
FINAL DISPOSAL LOCATION:	LANDFILL 13
DISPOSAL DATE:	09/03/13

I certify, on behalf of the above listed treatment facility, that to the best of my knowledge, the above-described waste material was managed in compliance with all applicable laws, regulations, permits and licenses on the date listed above.

Bobbi Jo Galvin

CWMNW RECORDS DEPARTMENT

Date: 09/12/13



CHEMICAL WASTE MANAGEMENT OF THE NW

17629 Cedar Springs Lane
Arlington, OR 97812
(541) 454-2643
(541) 454-3279 Fax

PORT OF TACOMA
WAD001882984
3400 TAYLOR WAY
TACOMA WA 98421

CERTIFICATE OF DISPOSAL

Chemical Waste Management of the Northwest, Inc., ORD089452353, has received the following waste material:

GENERATOR:	PORT OF TACOMA
MANIFEST #:	010585309JJK
CWM TRACKING ID:	42771401
PROFILE #:	OR321468
LINE ITEM:	9b.1
QUANTITY:	1 DT
RECEIVED DATE:	09/03/13
DISPOSAL PROCESS(ES):	LANDFILL
FINAL DISPOSAL LOCATION:	LANDFILL 13
DISPOSAL DATE:	09/03/13

I certify, on behalf of the above listed treatment facility, that to the best of my knowledge, the above-described waste material was managed in compliance with all applicable laws, regulations, permits and licenses on the date listed above.

Bobbi Galvin

CWMNW RECORDS DEPARTMENT

Date: 09/12/13



CHEMICAL WASTE MANAGEMENT OF THE NW

17629 Cedar Springs Lane
Arlington, OR 97812
(541) 454-2643
(541) 454-3279 Fax

PORT OF TACOMA
WAD001882984
3400 TAYLOR WAY
TACOMA WA 98421

CERTIFICATE OF DISPOSAL

Chemical Waste Management of the Northwest, Inc., ORD089452353, has received the following waste material:

GENERATOR: PORT OF TACOMA
MANIFEST #: 011880554JJK
CWM TRACKING ID: 42769201
PROFILE #: OR321468
LINE ITEM: 9b.1
QUANTITY: 1 DT
RECEIVED DATE: 09/03/13

DISPOSAL PROCESS(ES): LANDFILL
FINAL DISPOSAL LOCATION: LANDFILL 13
DISPOSAL DATE: 09/03/13

I certify, on behalf of the above listed treatment facility, that to the best of my knowledge, the above-described waste material was managed in compliance with all applicable laws, regulations, permits and licenses on the date listed above.



CWMNW RECORDS DEPARTMENT

Date: 09/16/13



CHEMICAL WASTE MANAGEMENT OF THE NW

17629 Cedar Springs Lane
Arlington, OR 97812
(541) 454-2643
(541) 454-3279 Fax

PORT OF TACOMA
WAD001882984
3400 TAYLOR WAY
TACOMA WA 98421

CERTIFICATE OF DISPOSAL

Chemical Waste Management of the Northwest, Inc., ORD089452353, has received the following waste material:

GENERATOR:	PORT OF TACOMA
MANIFEST #:	010585314JJK
CWM TRACKING ID:	42774301
PROFILE #:	OR321468
LINE ITEM:	9b.1
QUANTITY:	1 DT
RECEIVED DATE:	09/04/13
DISPOSAL PROCESS(ES):	LANDFILL
FINAL DISPOSAL LOCATION:	LANDFILL 13
DISPOSAL DATE:	09/04/13

I certify, on behalf of the above listed treatment facility, that to the best of my knowledge, the above-described waste material was managed in compliance with all applicable laws, regulations, permits and licenses on the date listed above.

Bobbi Jobalvin

CWMNW RECORDS DEPARTMENT

Date: 09/13/13



CHEMICAL WASTE MANAGEMENT OF THE NW

17629 Cedar Springs Lane
Arlington, OR 97812
(541) 454-2643
(541) 454-3279 Fax

PORT OF TACOMA
WAD001882984
3400 TAYLOR WAY
TACOMA WA 98421

CERTIFICATE OF DISPOSAL

Chemical Waste Management of the Northwest, Inc., ORD089452353, has received the following waste material:

GENERATOR:	PORT OF TACOMA
MANIFEST #:	011880552JJK
CWM TRACKING ID:	42774701
PROFILE #:	OR321468
LINE ITEM:	9b.1
QUANTITY:	1 DT
RECEIVED DATE:	09/04/13
DISPOSAL PROCESS(ES):	LANDFILL
FINAL DISPOSAL LOCATION:	LANDFILL 13
DISPOSAL DATE:	09/04/13

I certify, on behalf of the above listed treatment facility, that to the best of my knowledge, the above-described waste material was managed in compliance with all applicable laws, regulations, permits and licenses on the date listed above.

Bobbi Jobalvin

CWMNW RECORDS DEPARTMENT

Date: 09/13/13



CHEMICAL WASTE MANAGEMENT OF THE NW
17629 Cedar Springs Lane
Arlington, OR 97812
(541) 454-2643
(541) 454-3279 Fax

PORT OF TACOMA
WAD001882984
3400 TAYLOR WAY
TACOMA WA 98421

CERTIFICATE OF DISPOSAL

Chemical Waste Management of the Northwest, Inc., ORD089452353, has received the following waste material:

GENERATOR:	PORT OF TACOMA
MANIFEST #:	011880705JJK
CWM TRACKING ID:	42775601
PROFILE #:	OR321468
LINE ITEM:	9b.1
QUANTITY:	1 DT
RECEIVED DATE:	09/04/13
DISPOSAL PROCESS(ES):	LANDFILL
FINAL DISPOSAL LOCATION:	LANDFILL 13
DISPOSAL DATE:	09/04/13

I certify, on behalf of the above listed treatment facility, that to the best of my knowledge, the above-described waste material was managed in compliance with all applicable laws, regulations, permits and licenses on the date listed above.

Robbi Jo Balvin

CWMNW RECORDS DEPARTMENT

Date: 09/13/13



CHEMICAL WASTE MANAGEMENT OF THE NW

17629 Cedar Springs Lane
Arlington, OR 97812
(541) 454-2643
(541) 454-3279 Fax

PORT OF TACOMA
WAD001882984
3400 TAYLOR WAY
TACOMA WA 98421

CERTIFICATE OF DISPOSAL

Chemical Waste Management of the Northwest, Inc., ORD089452353, has received the following waste material:

GENERATOR: PORT OF TACOMA
MANIFEST #: 011880703JJK
CWM TRACKING ID: 42775701
PROFILE #: OR321468
LINE ITEM: 9b.1
QUANTITY: 1 DT
RECEIVED DATE: 09/04/13

DISPOSAL PROCESS(ES): LANDFILL
FINAL DISPOSAL LOCATION: LANDFILL 13
DISPOSAL DATE: 09/04/13

I certify, on behalf of the above listed treatment facility, that to the best of my knowledge, the above-described waste material was managed in compliance with all applicable laws, regulations, permits and licenses on the date listed above.



CWMNW RECORDS DEPARTMENT

Date: 09/13/13



CHEMICAL WASTE MANAGEMENT OF THE NW
17629 Cedar Springs Lane
Arlington, OR 97812
(541) 454-2643
(541) 454-3279 Fax

PORT OF TACOMA
WAD001882984
3400 TAYLOR WAY
TACOMA WA 98421

CERTIFICATE OF DISPOSAL

Chemical Waste Management of the Northwest, Inc., ORD089452353, has received the following waste material:

GENERATOR:	PORT OF TACOMA
MANIFEST #:	011880704JJK
CWM TRACKING ID:	42775901
PROFILE #:	OR321468
LINE ITEM:	9b.1
QUANTITY:	1 DT
RECEIVED DATE:	09/04/13
DISPOSAL PROCESS(ES):	LANDFILL
FINAL DISPOSAL LOCATION:	LANDFILL 13
DISPOSAL DATE:	09/04/13

I certify, on behalf of the above listed treatment facility, that to the best of my knowledge, the above-described waste material was managed in compliance with all applicable laws, regulations, permits and licenses on the date listed above.

Bobbi Galun

CWMNW RECORDS DEPARTMENT

Date: 09/13/13



CHEMICAL WASTE MANAGEMENT OF THE NW
17629 Cedar Springs Lane
Arlington, OR 97812
(541) 454-2643
(541) 454-3279 Fax

PORT OF TACOMA
WAD001882984
3400 TAYLOR WAY
TACOMA WA 98421

CERTIFICATE OF DISPOSAL

Chemical Waste Management of the Northwest, Inc., ORD089452353, has received the following waste material:

GENERATOR: PORT OF TACOMA
MANIFEST #: 011880707JJK
CWM TRACKING ID: 42776101
PROFILE #: OR321468
LINE ITEM: 9b.1
QUANTITY: 1 D7
RECEIVED DATE: 09/04/13

DISPOSAL PROCESS(ES): LANDFILL
FINAL DISPOSAL LOCATION: LANDFILL 13
DISPOSAL DATE: 09/04/13

I certify, on behalf of the above listed treatment facility, that to the best of my knowledge, the above-described waste material was managed in compliance with all applicable laws, regulations, permits and licenses on the date listed above.



CWMNW RECORDS DEPARTMENT

Date: 09/13/13



CHEMICAL WASTE MANAGEMENT OF THE NW
17629 Cedar Springs Lane
Arlington, OR 97812
(541) 454-2643
(541) 454-3279 Fax

PORT OF TACOMA
WAD001882984
3400 TAYLOR WAY
TACOMA WA 98421

CERTIFICATE OF DISPOSAL

Chemical Waste Management of the Northwest, Inc., ORD089452353, has received the following waste material:

GENERATOR:	PORT OF TACOMA
MANIFEST #:	011880706JJK
CWM TRACKING ID:	42776201
PROFILE #:	OR321468
LINE ITEM:	9b.1
QUANTITY:	1 DT
RECEIVED DATE:	09/04/13
DISPOSAL PROCESS(ES):	LANDFILL
FINAL DISPOSAL LOCATION:	LANDFILL 13
DISPOSAL DATE:	09/04/13

I certify, on behalf of the above listed treatment facility, that to the best of my knowledge, the above-described waste material was managed in compliance with all applicable laws, regulations, permits and licenses on the date listed above.



CWMNW RECORDS DEPARTMENT
Date: 09/13/13



CHEMICAL WASTE MANAGEMENT OF THE NW

17629 Cedar Springs Lane
Arlington, OR 97812
(541) 454-2643
(541) 454-3279 Fax

PORT OF TACOMA
WAD001882984
3400 TAYLOR WAY
TACOMA WA 98421

CERTIFICATE OF DISPOSAL

Chemical Waste Management of the Northwest, Inc., ORD089452353, has received the following waste material:

GENERATOR:	PORT OF TACOMA
MANIFEST #:	011880702JJK
CWM TRACKING ID:	42776401
PROFILE #:	OR321468
LINE ITEM:	9b.1
QUANTITY:	1 DT
RECEIVED DATE:	09/04/13
DISPOSAL PROCESS(ES):	LANDFILL
FINAL DISPOSAL LOCATION:	LANDFILL 13
DISPOSAL DATE:	09/04/13

I certify, on behalf of the above listed treatment facility, that to the best of my knowledge, the above-described waste material was managed in compliance with all applicable laws, regulations, permits and licenses on the date listed above.

Bobbin Galvin

CWMNW RECORDS DEPARTMENT

Date: 09/13/13



CHEMICAL WASTE MANAGEMENT OF THE NW

17629 Cedar Springs Lane
Arlington, OR 97812
(541) 454-2643
(541) 454-3279 Fax

PORT OF TACOMA
WAD001882984
3400 TAYLOR WAY
TACOMA WA 98421

CERTIFICATE OF DISPOSAL

Chemical Waste Management of the Northwest, Inc., ORD089452353, has received the following waste material:

GENERATOR: PORT OF TACOMA
MANIFEST #: 011880692JJK
CWM TRACKING ID: 42777001
PROFILE #: OR321468
LINE ITEM: 9b.1
QUANTITY: 1 DT
RECEIVED DATE: 09/04/13

DISPOSAL PROCESS(ES): LANDFILL
FINAL DISPOSAL LOCATION: LANDFILL 13
DISPOSAL DATE: 09/04/13

I certify, on behalf of the above listed treatment facility, that to the best of my knowledge, the above-described waste material was managed in compliance with all applicable laws, regulations, permits and licenses on the date listed above.



CWMNW RECORDS DEPARTMENT

Date: 09/13/13



CHEMICAL WASTE MANAGEMENT OF THE NW

17629 Cedar Springs Lane
Arlington, OR 97812
(541) 454-2643
(541) 454-3279 Fax

PORT OF TACOMA
WAD001882984
3400 TAYLOR WAY
TACOMA WA 98421

CERTIFICATE OF DISPOSAL

Chemical Waste Management of the Northwest, Inc., ORD089452353, has received the following waste material:

GENERATOR:	PORT OF TACOMA
MANIFEST #:	011880693JJK
CWM TRACKING ID:	42777101
PROFILE #:	OR321468
LINE ITEM:	9b.1
QUANTITY:	1 DT
RECEIVED DATE:	09/04/13
DISPOSAL PROCESS(ES):	LANDFILL
FINAL DISPOSAL LOCATION:	LANDFILL 13
DISPOSAL DATE:	09/04/13

I certify, on behalf of the above listed treatment facility, that to the best of my knowledge, the above-described waste material was managed in compliance with all applicable laws, regulations, permits and licenses on the date listed above.

Robbie Galvin

CWMNW RECORDS DEPARTMENT

Date: 09/13/13



CHEMICAL WASTE MANAGEMENT OF THE NW

17629 Cedar Springs Lane
Arlington, OR 97812
(541) 454-2643
(541) 454-3279 Fax

PORT OF TACOMA
WAD001882984
3400 TAYLOR WAY
TACOMA WA 98421

CERTIFICATE OF DISPOSAL

Chemical Waste Management of the Northwest, Inc., ORD089452353, has received the following waste material:

GENERATOR:	PORT OF TACOMA
MANIFEST #:	011880696JJK
CWM TRACKING ID:	42777301
PROFILE #:	OR321468
LINE ITEM:	9b.1
QUANTITY:	1 DT
RECEIVED DATE:	09/04/13
DISPOSAL PROCESS(ES):	LANDFILL
FINAL DISPOSAL LOCATION:	LANDFILL 13
DISPOSAL DATE:	09/04/13

I certify, on behalf of the above listed treatment facility, that to the best of my knowledge, the above-described waste material was managed in compliance with all applicable laws, regulations, permits and licenses on the date listed above.



CWMNW RECORDS DEPARTMENT

Date: 09/13/13



CHEMICAL WASTE MANAGEMENT OF THE NW

17629 Cedar Springs Lane
Arlington, OR 97812
(541) 454-2643
(541) 454-3279 Fax

PORT OF TACOMA
WAD001882984
3400 TAYLOR WAY
TACOMA WA 98421

CERTIFICATE OF DISPOSAL

Chemical Waste Management of the Northwest, Inc., ORD089452353, has received the following waste material:

GENERATOR:	PORT OF TACOMA
MANIFEST #:	011880694JJK
CWM TRACKING ID:	42777401
PROFILE #:	OR321468
LINE ITEM:	9b.1
QUANTITY:	1 DT
RECEIVED DATE:	09/04/13
DISPOSAL PROCESS(ES):	LANDFILL
FINAL DISPOSAL LOCATION:	LANDFILL 13
DISPOSAL DATE:	09/04/13

I certify, on behalf of the above listed treatment facility, that to the best of my knowledge, the above-described waste material was managed in compliance with all applicable laws, regulations, permits and licenses on the date listed above.



CWMNW RECORDS DEPARTMENT

Date: 09/13/13



CHEMICAL WASTE MANAGEMENT OF THE NW

17629 Cedar Springs Lane
Arlington, OR 97812
(541) 454-2643
(541) 454-3279 Fax

PORT OF TACOMA
WAD001882984
3400 TAYLOR WAY
TACOMA WA 98421

CERTIFICATE OF DISPOSAL

Chemical Waste Management of the Northwest, Inc., ORD089452353, has received the following waste material:

GENERATOR: PORT OF TACOMA
MANIFEST #: 011880699JJK
CWM TRACKING ID: 42777501
PROFILE #: OR321468
LINE ITEM: 9b.1
QUANTITY: 1 DT
RECEIVED DATE: 09/04/13

DISPOSAL PROCESS(ES): LANDFILL
FINAL DISPOSAL LOCATION: LANDFILL 13
DISPOSAL DATE: 09/04/13

I certify, on behalf of the above listed treatment facility, that to the best of my knowledge, the above-described waste material was managed in compliance with all applicable laws, regulations, permits and licenses on the date listed above.



CWMNW RECORDS DEPARTMENT

Date: 09/13/13



CHEMICAL WASTE MANAGEMENT OF THE NW

17629 Cedar Springs Lane
Arlington, OR 97812
(541) 454-2643
(541) 454-3279 Fax

PORT OF TACOMA
WAD001882984
3400 TAYLOR WAY
TACOMA WA 98421

CERTIFICATE OF DISPOSAL

Chemical Waste Management of the Northwest, Inc., ORD089452353, has received the following waste material:

GENERATOR:	PORT OF TACOMA
MANIFEST #:	011880697JJK
CWM TRACKING ID:	42777701
PROFILE #:	OR321468
LINE ITEM:	9b.1
QUANTITY:	1 DT
RECEIVED DATE:	09/04/13
DISPOSAL PROCESS(ES):	LANDFILL
FINAL DISPOSAL LOCATION:	LANDFILL 13
DISPOSAL DATE:	09/04/13

I certify, on behalf of the above listed treatment facility, that to the best of my knowledge, the above-described waste material was managed in compliance with all applicable laws, regulations, permits and licenses on the date listed above.

Bobbi Jo Galvin

CWMNW RECORDS DEPARTMENT

Date: 09/13/13



CHEMICAL WASTE MANAGEMENT OF THE NW

17629 Cedar Springs Lane
Arlington, OR 97812
(541) 454-2643
(541) 454-3279 Fax

PORT OF TACOMA
WAD001882984
3400 TAYLOR WAY
TACOMA WA 98421

CERTIFICATE OF DISPOSAL

Chemical Waste Management of the Northwest, Inc., ORD089452353, has received the following waste material:

GENERATOR:	PORT OF TACOMA
MANIFEST #:	011880698JJK
CWM TRACKING ID:	42777801
PROFILE #:	OR321468
LINE ITEM:	9b.1
QUANTITY:	1 DT
RECEIVED DATE:	09/04/13
DISPOSAL PROCESS(ES):	LANDFILL
FINAL DISPOSAL LOCATION:	LANDFILL 13
DISPOSAL DATE:	09/04/13

I certify, on behalf of the above listed treatment facility, that to the best of my knowledge, the above-described waste material was managed in compliance with all applicable laws, regulations, permits and licenses on the date listed above.



CWMNW RECORDS DEPARTMENT

Date: 09/13/13



CHEMICAL WASTE MANAGEMENT OF THE NW

17629 Cedar Springs Lane
Arlington, OR 97812
(541) 454-2643
(541) 454-3279 Fax

PORT OF TACOMA
WAD001882984
3400 TAYLOR WAY
TACOMA WA 98421

CERTIFICATE OF DISPOSAL

Chemical Waste Management of the Northwest, Inc., ORD089452353, has received the following waste material:

GENERATOR:	PORT OF TACOMA
MANIFEST #:	011880689JJK
CWM TRACKING ID:	42717901
PROFILE #:	OR321468
LINE ITEM:	9b.1
QUANTITY:	1 DT
RECEIVED DATE:	09/04/13
DISPOSAL PROCESS(ES):	LANDFILL
FINAL DISPOSAL LOCATION:	LANDFILL 13
DISPOSAL DATE:	09/04/13

I certify, on behalf of the above listed treatment facility, that to the best of my knowledge, the above-described waste material was managed in compliance with all applicable laws, regulations, permits and licenses on the date listed above.

Bobbi J. Galvin

CWMNW RECORDS DEPARTMENT

Date: 09/13/13



CHEMICAL WASTE MANAGEMENT OF THE NW

17629 Cedar Springs Lane
Arlington, OR 97812
(541) 454-2643
(541) 454-3279 Fax

PORT OF TACOMA
WAD001882984
3400 TAYLOR WAY
TACOMA WA 98421

CERTIFICATE OF DISPOSAL

Chemical Waste Management of the Northwest, Inc., ORD089452353, has received the following waste material:

GENERATOR:	PORT OF TACOMA
MANIFEST #:	011880700JJK
CWM TRACKING ID:	42778001
PROFILE #:	OR321468
LINE ITEM:	9b.1
QUANTITY:	1 DT
RECEIVED DATE:	09/04/13
DISPOSAL PROCESS(ES):	LANDFILL
FINAL DISPOSAL LOCATION:	LANDFILL 13
DISPOSAL DATE:	09/04/13

I certify, on behalf of the above listed treatment facility, that to the best of my knowledge, the above-described waste material was managed in compliance with all applicable laws, regulations, permits and licenses on the date listed above.

Bobbi Jo Galvin

CWMNW RECORDS DEPARTMENT

Date: 09/13/13



CHEMICAL WASTE MANAGEMENT OF THE NW

17629 Cedar Springs Lane
Arlington, OR 97812
(541) 454-2643
(541) 454-3279 Fax

PORT OF TACOMA
WAD001882984
3400 TAYLOR WAY
TACOMA WA 98421

CERTIFICATE OF DISPOSAL

Chemical Waste Management of the Northwest, Inc., ORD089452353, has received the following waste material:

GENERATOR:	PORT OF TACOMA
MANIFEST #:	011880695JJK
CWM TRACKING ID:	42778101
PROFILE #:	OR321468
LINE ITEM:	9b.1
QUANTITY:	1 DT
RECEIVED DATE:	09/04/13
DISPOSAL PROCESS(ES):	LANDFILL
FINAL DISPOSAL LOCATION:	LANDFILL 13
DISPOSAL DATE:	09/04/13

I certify, on behalf of the above listed treatment facility, that to the best of my knowledge, the above-described waste material was managed in compliance with all applicable laws, regulations, permits and licenses on the date listed above.

Bobbi Jo Galvin

CWMNW RECORDS DEPARTMENT

Date: 09/13/13



CHEMICAL WASTE MANAGEMENT OF THE NW

17629 Cedar Springs Lane
Arlington, OR 97812
(541) 454-2643
(541) 454-3279 Fax

PORT OF TACOMA
WAD001882984
3400 TAYLOR WAY
TACOMA WA 98421

CERTIFICATE OF DISPOSAL

Chemical Waste Management of the Northwest, Inc., ORD089452353, has received the following waste material:

GENERATOR:	PORT OF TACOMA
MANIFEST #:	011880691JJK
CWM TRACKING ID:	42778401
PROFILE #:	OR321468
LINE ITEM:	9b.1
QUANTITY:	1 DT
RECEIVED DATE:	09/04/13
DISPOSAL PROCESS(ES):	LANDFILL
FINAL DISPOSAL LOCATION:	LANDFILL 13
DISPOSAL DATE:	09/04/13

I certify, on behalf of the above listed treatment facility, that to the best of my knowledge, the above-described waste material was managed in compliance with all applicable laws, regulations, permits and licenses on the date listed above.

Bobbi Baldwin

CWMNW RECORDS DEPARTMENT

Date: 09/13/13



CHEMICAL WASTE MANAGEMENT OF THE NW
17629 Cedar Springs Lane
Arlington, OR 97812
(541) 454-2643
(541) 454-3279 Fax

PORT OF TACOMA
WAD001882984
3400 TAYLOR WAY
TACOMA WA 98421

CERTIFICATE OF DISPOSAL

Chemical Waste Management of the Northwest, Inc., ORD089452353, has received the following waste material:

GENERATOR:	PORT OF TACOMA
MANIFEST #:	011880701JJK
CWM TRACKING ID:	42778201
PROFILE #:	OR321468
LINE ITEM:	9b.1
QUANTITY:	1 DT
RECEIVED DATE:	09/04/13
DISPOSAL PROCESS(ES):	LANDFILL
FINAL DISPOSAL LOCATION:	LANDFILL 13
DISPOSAL DATE:	09/04/13

I certify, on behalf of the above listed treatment facility, that to the best of my knowledge, the above-described waste material was managed in compliance with all applicable laws, regulations, permits and licenses on the date listed above.

Bobbin Bobbin

CWMNW RECORDS DEPARTMENT

Date: 09/17/13



CHEMICAL WASTE MANAGEMENT OF THE NW

17629 Cedar Springs Lane
Arlington, OR 97812
(541) 454-2643
(541) 454-3279 Fax

PORT OF TACOMA
WAD001882984
3400 TAYLOR WAY
TACOMA WA 98421

CERTIFICATE OF DISPOSAL

Chemical Waste Management of the Northwest, Inc., ORD089452353, has received the following waste material:

GENERATOR: PORT OF TACOMA
MANIFEST #: 011880708JJK
CWM TRACKING ID: 42780101
PROFILE #: OR321468
LINE ITEM: 9b.1
QUANTITY: 1 DT
RECEIVED DATE: 09/05/13

DISPOSAL PROCESS(ES): LANDFILL
FINAL DISPOSAL LOCATION: LANDFILL 13
DISPOSAL DATE: 09/05/13

I certify, on behalf of the above listed treatment facility, that to the best of my knowledge, the above-described waste material was managed in compliance with all applicable laws, regulations, permits and licenses on the date listed above.

Bobbi Jo Balvin

CWMNW RECORDS DEPARTMENT

Date: 09/16/13



CHEMICAL WASTE MANAGEMENT OF THE NW

17629 Cedar Springs Lane
Arlington, OR 97812
(541) 454-2643
(541) 454-3279 Fax

PORT OF TACOMA
WAD001882984
3400 TAYLOR WAY
TACOMA WA 98421

CERTIFICATE OF DISPOSAL

Chemical Waste Management of the Northwest, Inc., ORD089452353, has received the following waste material:

GENERATOR:	PORT OF TACOMA
MANIFEST #:	011880690JJK
CWM TRACKING ID:	42780201
PROFILE #:	OR321468
LINE ITEM:	9b.1
QUANTITY:	1 DT
RECEIVED DATE:	09/05/13
DISPOSAL PROCESS(ES):	LANDFILL
FINAL DISPOSAL LOCATION:	LANDFILL 13
DISPOSAL DATE:	09/05/13

I certify, on behalf of the above listed treatment facility, that to the best of my knowledge, the above-described waste material was managed in compliance with all applicable laws, regulations, permits and licenses on the date listed above.



CWMNW RECORDS DEPARTMENT
Date: 09/16/13



CHEMICAL WASTE MANAGEMENT OF THE NW

17629 Cedar Springs Lane
Arlington, OR 97812
(541) 454-2643
(541) 454-3279 Fax

PORT OF TACOMA
WAD001882984
3400 TAYLOR WAY
TACOMA WA 98421

CERTIFICATE OF DISPOSAL

Chemical Waste Management of the Northwest, Inc., ORD089452353, has received the following waste material:

GENERATOR: PORT OF TACOMA
MANIFEST #: 011880712JJK
CWM TRACKING ID: 42781101
PROFILE #: OR321468
LINE ITEM: 9b.1
QUANTITY: 1 DT
RECEIVED DATE: 09/05/13

DISPOSAL PROCESS(ES): LANDFILL
FINAL DISPOSAL LOCATION: LANDFILL 13
DISPOSAL DATE: 09/05/13

I certify, on behalf of the above listed treatment facility, that to the best of my knowledge, the above-described waste material was managed in compliance with all applicable laws, regulations, permits and licenses on the date listed above.



CWMNW RECORDS DEPARTMENT

Date: 09/16/13



CHEMICAL WASTE MANAGEMENT OF THE NW

17629 Cedar Springs Lane
Arlington, OR 97812
(541) 454-2643
(541) 454-3279 Fax

PORT OF TACOMA
WAD001882984
3400 TAYLOR WAY
TACOMA WA 98421

CERTIFICATE OF DISPOSAL

Chemical Waste Management of the Northwest, Inc., ORD089452353, has received the following waste material:

GENERATOR:	PORT OF TACOMA
MANIFEST #:	011880713JJK
CWM TRACKING ID:	42781201
PROFILE #:	OR321468
LINE ITEM:	9b.1
QUANTITY:	1 DT
RECEIVED DATE:	09/05/13
DISPOSAL PROCESS(ES):	LANDFILL
FINAL DISPOSAL LOCATION:	LANDFILL 13
DISPOSAL DATE:	09/05/13

I certify, on behalf of the above listed treatment facility, that to the best of my knowledge, the above-described waste material was managed in compliance with all applicable laws, regulations, permits and licenses on the date listed above.

Bobbi Jo Galvin

CWMNW RECORDS DEPARTMENT

Date: 09/16/13



CHEMICAL WASTE MANAGEMENT OF THE NW

17629 Cedar Springs Lane
Arlington, OR 97812
(541) 454-2643
(541) 454-3279 Fax

PORT OF TACOMA
WAD001882984
3400 TAYLOR WAY
TACOMA WA 98421

CERTIFICATE OF DISPOSAL

Chemical Waste Management of the Northwest, Inc., ORD089452353, has received the following waste material:

GENERATOR:	PORT OF TACOMA
MANIFEST #:	011880715JJK
CWM TRACKING ID:	42781301
PROFILE #:	OR321468
LINE ITEM:	9b.1
QUANTITY:	1 DT
RECEIVED DATE:	09/05/13
DISPOSAL PROCESS(ES):	LANDFILL
FINAL DISPOSAL LOCATION:	LANDFILL 13
DISPOSAL DATE:	09/05/13

I certify, on behalf of the above listed treatment facility, that to the best of my knowledge, the above-described waste material was managed in compliance with all applicable laws, regulations, permits and licenses on the date listed above.



CWMNW RECORDS DEPARTMENT

Date: 09/16/13



CHEMICAL WASTE MANAGEMENT OF THE NW

17629 Cedar Springs Lane
Arlington, OR 97812
(541) 454-2643
(541) 454-3279 Fax

PORT OF TACOMA
WAD001882984
3400 TAYLOR WAY
TACOMA WA 98421

CERTIFICATE OF DISPOSAL

Chemical Waste Management of the Northwest, Inc., ORD089452353, has received the following waste material:

GENERATOR:	PORT OF TACOMA
MANIFEST #:	011880720JJK
CWM TRACKING ID:	42781401
PROFILE #:	OR321468
LINE ITEM:	9b.1
QUANTITY:	1 DT
RECEIVED DATE:	09/05/13
DISPOSAL PROCESS(ES):	LANDFILL
FINAL DISPOSAL LOCATION:	LANDFILL 13
DISPOSAL DATE:	09/05/13

I certify, on behalf of the above listed treatment facility, that to the best of my knowledge, the above-described waste material was managed in compliance with all applicable laws, regulations, permits and licenses on the date listed above.

Bobbi Jo Galvin

CWMNW RECORDS DEPARTMENT

Date: 09/16/13



CHEMICAL WASTE MANAGEMENT OF THE NW

17629 Cedar Springs Lane
Arlington, OR 97812
(541) 454-2643
(541) 454-3279 Fax

PORT OF TACOMA
WAD001882984
3400 TAYLOR WAY
TACOMA WA 98421

CERTIFICATE OF DISPOSAL

Chemical Waste Management of the Northwest, Inc., ORD089452353, has received the following waste material:

GENERATOR:	PORT OF TACOMA
MANIFEST #:	011880722JJK
CWM TRACKING ID:	42781601
PROFILE #:	OR321468
LINE ITEM:	9b.1
QUANTITY:	1 DT
RECEIVED DATE:	09/05/13
DISPOSAL PROCESS(ES):	LANDFILL
FINAL DISPOSAL LOCATION:	LANDFILL 13
DISPOSAL DATE:	09/05/13

I certify, on behalf of the above listed treatment facility, that to the best of my knowledge, the above-described waste material was managed in compliance with all applicable laws, regulations, permits and licenses on the date listed above.

Bobbi Jobalun

CWMNW RECORDS DEPARTMENT

Date: 09/13/13



CHEMICAL WASTE MANAGEMENT OF THE NW

17629 Cedar Springs Lane
Arlington, OR 97812
(541) 454-2643
(541) 454-3279 Fax

PORT OF TACOMA
WAD001882984
3400 TAYLOR WAY
TACOMA WA 98421

CERTIFICATE OF DISPOSAL

Chemical Waste Management of the Northwest, Inc., ORD089452353, has received the following waste material:

GENERATOR:	PORT OF TACOMA
MANIFEST #:	011880709JJK
CWM TRACKING ID:	42781701
PROFILE #:	OR321468
LINE ITEM:	9b.1
QUANTITY:	1 DT
RECEIVED DATE:	09/05/13
DISPOSAL PROCESS(ES):	LANDFILL
FINAL DISPOSAL LOCATION:	LANDFILL 13
DISPOSAL DATE:	09/05/13

I certify, on behalf of the above listed treatment facility, that to the best of my knowledge, the above-described waste material was managed in compliance with all applicable laws, regulations, permits and licenses on the date listed above.



CWMNW RECORDS DEPARTMENT

Date: 09/16/13



CHEMICAL WASTE MANAGEMENT OF THE NW

17629 Cedar Springs Lane
Arlington, OR 97812
(541) 454-2643
(541) 454-3279 Fax

PORT OF TACOMA
WAD001882984
3400 TAYLOR WAY
TACOMA WA 98421

CERTIFICATE OF DISPOSAL

Chemical Waste Management of the Northwest, Inc., ORD089452353, has received the following waste material:

GENERATOR: PORT OF TACOMA
MANIFEST #: 011880716JJK
CWM TRACKING ID: 42781801
PROFILE #: OR321468
LINE ITEM: 9b.1
QUANTITY: 1 DT
RECEIVED DATE: 09/05/13

DISPOSAL PROCESS(ES): LANDFILL
FINAL DISPOSAL LOCATION: LANDFILL 13
DISPOSAL DATE: 09/05/13

I certify, on behalf of the above listed treatment facility, that to the best of my knowledge, the above-described waste material was managed in compliance with all applicable laws, regulations, permits and licenses on the date listed above.

Bobbi Jo Galvin

CWMNW RECORDS DEPARTMENT

Date: 09/13/13



CHEMICAL WASTE MANAGEMENT OF THE NW

17629 Cedar Springs Lane
Arlington, OR 97812
(541) 454-2643
(541) 454-3279 Fax

PORT OF TACOMA
WAD001882984
3400 TAYLOR WAY
TACOMA WA 98421

CERTIFICATE OF DISPOSAL

Chemical Waste Management of the Northwest, Inc., ORD089452353, has received the following waste material:

GENERATOR:	PORT OF TACOMA
MANIFEST #:	011880714JJK
CWM TRACKING ID:	42781901
PROFILE #:	OR321468
LINE ITEM:	9b.1
QUANTITY:	1 DT
RECEIVED DATE:	09/05/13
DISPOSAL PROCESS(ES):	LANDFILL
FINAL DISPOSAL LOCATION:	LANDFILL 13
DISPOSAL DATE:	09/05/13

I certify, on behalf of the above listed treatment facility, that to the best of my knowledge, the above-described waste material was managed in compliance with all applicable laws, regulations, permits and licenses on the date listed above.



CWMNW RECORDS DEPARTMENT

Date: 09/16/13



CHEMICAL WASTE MANAGEMENT OF THE NW

17629 Cedar Springs Lane
Arlington, OR 97812
(541) 454-2643
(541) 454-3279 Fax

PORT OF TACOMA
WAD001882984
3400 TAYLOR WAY
TACOMA WA 98421

CERTIFICATE OF DISPOSAL

Chemical Waste Management of the Northwest, Inc., ORD089452353, has received the following waste material:

GENERATOR:	PORT OF TACOMA
MANIFEST #:	011880721JJK
CWM TRACKING ID:	42782101
PROFILE #:	OR321468
LINE ITEM:	9b.1
QUANTITY:	1 DT
RECEIVED DATE:	09/05/13
DISPOSAL PROCESS(ES):	LANDFILL
FINAL DISPOSAL LOCATION:	LANDFILL 13
DISPOSAL DATE:	09/05/13

I certify, on behalf of the above listed treatment facility, that to the best of my knowledge, the above-described waste material was managed in compliance with all applicable laws, regulations, permits and licenses on the date listed above.

CWMNW RECORDS DEPARTMENT

Date: 09/16/13



CHEMICAL WASTE MANAGEMENT OF THE NW

17629 Cedar Springs Lane
Arlington, OR 97812
(541) 454-2643
(541) 454-3279 Fax

PORT OF TACOMA
WAD001882984
3400 TAYLOR WAY
TACOMA WA 98421

CERTIFICATE OF DISPOSAL

Chemical Waste Management of the Northwest, Inc., ORD089452353, has received the following waste material:

GENERATOR:	PORT OF TACOMA
MANIFEST #:	011880717JJK
CWM TRACKING ID:	42782301
PROFILE #:	OR321468
LINE ITEM:	9b.1
QUANTITY:	1 DT
RECEIVED DATE:	09/05/13
DISPOSAL PROCESS(ES):	LANDFILL
FINAL DISPOSAL LOCATION:	LANDFILL 13
DISPOSAL DATE:	09/05/13

I certify, on behalf of the above listed treatment facility, that to the best of my knowledge, the above-described waste material was managed in compliance with all applicable laws, regulations, permits and licenses on the date listed above.



CWMNW RECORDS DEPARTMENT

Date: 09/16/13



CHEMICAL WASTE MANAGEMENT OF THE NW

17629 Cedar Springs Lane
Arlington, OR 97812
(541) 454-2643
(541) 454-3279 Fax

PORT OF TACOMA
WAD001882984
3400 TAYLOR WAY
TACOMA WA 98421

CERTIFICATE OF DISPOSAL

Chemical Waste Management of the Northwest, Inc., ORD089452353, has received the following waste material:

GENERATOR: PORT OF TACOMA
MANIFEST #: 011880719JJK
CWM TRACKING ID: 42782401
PROFILE #: OR321468
LINE ITEM: 9b.1
QUANTITY: 1 DT
RECEIVED DATE: 09/05/13

DISPOSAL PROCESS(ES): LANDFILL
FINAL DISPOSAL LOCATION: LANDFILL 13
DISPOSAL DATE: 09/05/13

I certify, on behalf of the above listed treatment facility, that to the best of my knowledge, the above-described waste material was managed in compliance with all applicable laws, regulations, permits and licenses on the date listed above.

Bobbi Jo Galvin

CWMNW RECORDS DEPARTMENT

Date:

09/16/13



CHEMICAL WASTE MANAGEMENT OF THE NW

17629 Cedar Springs Lane
Arlington, OR 97812
(541) 454-2643
(541) 454-3279 Fax

PORT OF TACOMA
WAD001882984
3400 TAYLOR WAY
TACOMA WA 98421

CERTIFICATE OF DISPOSAL

Chemical Waste Management of the Northwest, Inc., ORD089452353, has received the following waste material:

GENERATOR:	PORT OF TACOMA
MANIFEST #:	011880725JJK
CWM TRACKING ID:	42782601
PROFILE #:	OR321468
LINE ITEM:	9b.1
QUANTITY:	1 DT
RECEIVED DATE:	09/05/13
DISPOSAL PROCESS(ES):	LANDFILL
FINAL DISPOSAL LOCATION:	LANDFILL 13
DISPOSAL DATE:	09/05/13

I certify, on behalf of the above listed treatment facility, that to the best of my knowledge, the above-described waste material was managed in compliance with all applicable laws, regulations, permits and licenses on the date listed above.



CWMNW RECORDS DEPARTMENT

Date: 09/16/13



CHEMICAL WASTE MANAGEMENT OF THE NW

17629 Cedar Springs Lane
Arlington, OR 97812
(541) 454-2643
(541) 454-3279 Fax

PORT OF TACOMA
WAD001882984
3400 TAYLOR WAY
TACOMA WA 98421

CERTIFICATE OF DISPOSAL

Chemical Waste Management of the Northwest, Inc., ORD089452353, has received the following waste material:

GENERATOR:	PORT OF TACOMA
MANIFEST #:	011880711JJK
CWM TRACKING ID:	42782701
PROFILE #:	OR321468
LINE ITEM:	9b.1
QUANTITY:	1 DT
RECEIVED DATE:	09/05/13
DISPOSAL PROCESS(ES):	LANDFILL
FINAL DISPOSAL LOCATION:	LANDFILL 13
DISPOSAL DATE:	09/05/13

I certify, on behalf of the above listed treatment facility, that to the best of my knowledge, the above-described waste material was managed in compliance with all applicable laws, regulations, permits and licenses on the date listed above.



CWMNW RECORDS DEPARTMENT

Date: 09/16/13



CHEMICAL WASTE MANAGEMENT OF THE NW

17629 Cedar Springs Lane
Arlington, OR 97812
(541) 454-2643
(541) 454-3279 Fax

PORT OF TACOMA
WAD001882984
3400 TAYLOR WAY
TACOMA WA 98421

CERTIFICATE OF DISPOSAL

Chemical Waste Management of the Northwest, Inc., ORD089452353, has received the following waste material:

GENERATOR: PORT OF TACOMA
MANIFEST #: 011880718JJK
CWM TRACKING ID: 42782801
PROFILE #: OR321468
LINE ITEM: 9b.1
QUANTITY: 1 DT
RECEIVED DATE: 09/05/13

DISPOSAL PROCESS(ES): LANDFILL
FINAL DISPOSAL LOCATION: LANDFILL 13
DISPOSAL DATE: 09/05/13

I certify, on behalf of the above listed treatment facility, that to the best of my knowledge, the above-described waste material was managed in compliance with all applicable laws, regulations, permits and licenses on the date listed above.

CWMNW RECORDS DEPARTMENT

Date: 09/16/13



CHEMICAL WASTE MANAGEMENT OF THE NW

17629 Cedar Springs Lane
Arlington, OR 97812
(541) 454-2643
(541) 454-3279 Fax

PORT OF TACOMA
WAD001882984
3400 TAYLOR WAY
TACOMA WA 98421

CERTIFICATE OF DISPOSAL

Chemical Waste Management of the Northwest, Inc., ORD089452353, has received the following waste material:

GENERATOR:	PORT OF TACOMA
MANIFEST #:	011880723JJK
CWM TRACKING ID:	42782901
PROFILE #:	OR321468
LINE ITEM:	9b.1
QUANTITY:	1 DT
RECEIVED DATE:	09/05/13
DISPOSAL PROCESS(ES):	LANDFILL
FINAL DISPOSAL LOCATION:	LANDFILL 13
DISPOSAL DATE:	09/05/13

I certify, on behalf of the above listed treatment facility, that to the best of my knowledge, the above-described waste material was managed in compliance with all applicable laws, regulations, permits and licenses on the date listed above.



CWMNW RECORDS DEPARTMENT

Date: 09/16/13



CHEMICAL WASTE MANAGEMENT OF THE NW

17629 Cedar Springs Lane
Arlington, OR 97812
(541) 454-2643
(541) 454-3279 Fax

PORT OF TACOMA
WAD001882984
3400 TAYLOR WAY
TACOMA WA 98421

CERTIFICATE OF DISPOSAL

Chemical Waste Management of the Northwest, Inc., ORD089452353, has received the following waste material:

GENERATOR:	PORT OF TACOMA
MANIFEST #:	011880724JJK
CWM TRACKING ID:	42783001
PROFILE #:	OR321468
LINE ITEM:	9b.1
QUANTITY:	1 DT
RECEIVED DATE:	09/05/13
DISPOSAL PROCESS(ES):	LANDFILL
FINAL DISPOSAL LOCATION:	LANDFILL 13
DISPOSAL DATE:	09/05/13

I certify, on behalf of the above listed treatment facility, that to the best of my knowledge, the above-described waste material was managed in compliance with all applicable laws, regulations, permits and licenses on the date listed above.

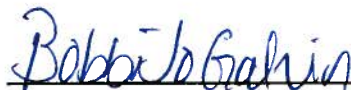

CWMNW RECORDS DEPARTMENT

Date: 09/16/13



CHEMICAL WASTE MANAGEMENT OF THE NW

17629 Cedar Springs Lane
Arlington, OR 97812
(541) 454-2643
(541) 454-3279 Fax

PORT OF TACOMA
WAD001882984
3400 TAYLOR WAY
TACOMA WA 98421

CERTIFICATE OF DISPOSAL

Chemical Waste Management of the Northwest, Inc., ORD089452353, has received the following waste material:

GENERATOR:	PORT OF TACOMA
MANIFEST #:	011880710JJK
CWM TRACKING ID:	427&3101
PROFILE #:	OR321468
LINE ITEM:	9b.1
QUANTITY:	1 DT
RECEIVED DATE:	09/05/13
DISPOSAL PROCESS(ES):	LANDFILL
FINAL DISPOSAL LOCATION:	LANDFILL 13
DISPOSAL DATE:	09/05/13

I certify, on behalf of the above listed treatment facility, that to the best of my knowledge, the above-described waste material was managed in compliance with all applicable laws, regulations, permits and licenses on the date listed above.

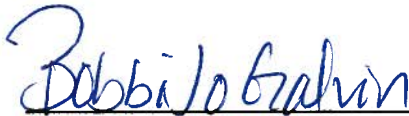

CWMNW RECORDS DEPARTMENT

Date: 09/16/13



CHEMICAL WASTE MANAGEMENT OF THE NW

17629 Cedar Springs Lane
Arlington, OR 97812
(541) 454-2643
(541) 454-3279 Fax

PORT OF TACOMA
WAD001882984
3400 TAYLOR WAY
TACOMA WA 98421

CERTIFICATE OF DISPOSAL

Chemical Waste Management of the Northwest, Inc., ORD089452353, has received the following waste material:

GENERATOR: PORT OF TACOMA
MANIFEST #: 011880733JJK
CWM TRACKING ID: 427870-01
PROFILE #: OR321468
LINE ITEM: 9b.1
QUANTITY: 1 DT
RECEIVED DATE: 09/06/13

DISPOSAL PROCESS(ES): SOLIDIFICATION FOLLOWED BY LANDFILL
FINAL DISPOSAL LOCATION: LANDFILL 13
DISPOSAL DATE: 09/09/13

I certify, on behalf of the above listed treatment facility, that to the best of my knowledge, the above-described waste material was managed in compliance with all applicable laws, regulations, permits and licenses on the date listed above.

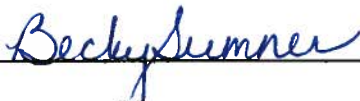

CWMNW RECORDS DEPARTMENT

Date: 09/20/13



CHEMICAL WASTE MANAGEMENT OF THE NW

17629 Cedar Springs Lane
Arlington, OR 97812
(541) 454-2643
(541) 454-3279 Fax

PORT OF TACOMA
WAD001882984
3400 TAYLOR WAY
TACOMA WA 98421

CERTIFICATE OF DISPOSAL

Chemical Waste Management of the Northwest, Inc., ORD089452353, has received the following waste material:

GENERATOR:	PORT OF TACOMA
MANIFEST #:	011880735JJK
CWM TRACKING ID:	42786401
PROFILE #:	OR321468
LINE ITEM:	9b.1
QUANTITY:	1 DT
RECEIVED DATE:	09/06/13
DISPOSAL PROCESS(ES):	LANDFILL
FINAL DISPOSAL LOCATION:	LANDFILL 13
DISPOSAL DATE:	09/06/13

I certify, on behalf of the above listed treatment facility, that to the best of my knowledge, the above-described waste material was managed in compliance with all applicable laws, regulations, permits and licenses on the date listed above.



CWMNW RECORDS DEPARTMENT

Date: 09/17/13



CHEMICAL WASTE MANAGEMENT OF THE NW

17629 Cedar Springs Lane
Arlington, OR 97812
(541) 454-2643
(541) 454-3279 Fax

PORT OF TACOMA
WAD001882984
3400 TAYLOR WAY
TACOMA WA 98421

CERTIFICATE OF DISPOSAL

Chemical Waste Management of the Northwest, Inc., ORD089452353, has received the following waste material:

GENERATOR:	PORT OF TACOMA
MANIFEST #:	011880748JJK
CWM TRACKING ID:	42784401
PROFILE #:	OR321468
LINE ITEM:	9b.1
QUANTITY:	1 DT
RECEIVED DATE:	09/06/13
DISPOSAL PROCESS(ES):	LANDFILL
FINAL DISPOSAL LOCATION:	LANDFILL 13
DISPOSAL DATE:	09/06/13

I certify, on behalf of the above listed treatment facility, that to the best of my knowledge, the above-described waste material was managed in compliance with all applicable laws, regulations, permits and licenses on the date listed above.

Bobbi Jo Gahin

CWMNW RECORDS DEPARTMENT

Date: 09/16/13



CHEMICAL WASTE MANAGEMENT OF THE NW

17629 Cedar Springs Lane
Arlington, OR 97812
(541) 454-2643
(541) 454-3279 Fax

PORT OF TACOMA
WAD001882984
3400 TAYLOR WAY
TACOMA WA 98421

CERTIFICATE OF DISPOSAL

Chemical Waste Management of the Northwest, Inc., ORD089452353, has received the following waste material:

GENERATOR:	PORT OF TACOMA
MANIFEST #:	011880746JJK
CWM TRACKING ID:	42784501
PROFILE #:	OR321468
LINE ITEM:	9b.1
QUANTITY:	1 DT
RECEIVED DATE:	09/06/13
DISPOSAL PROCESS(ES):	LANDFILL
FINAL DISPOSAL LOCATION:	LANDFILL 13
DISPOSAL DATE:	09/06/13

I certify, on behalf of the above listed treatment facility, that to the best of my knowledge, the above-described waste material was managed in compliance with all applicable laws, regulations, permits and licenses on the date listed above.

Bobbi Jo Galvin

CWMNW RECORDS DEPARTMENT

Date: 09/16/13



CHEMICAL WASTE MANAGEMENT OF THE NW

17629 Cedar Springs Lane
Arlington, OR 97812
(541) 454-2643
(541) 454-3279 Fax

PORT OF TACOMA
WAD001882984
3400 TAYLOR WAY
TACOMA WA 98421

CERTIFICATE OF DISPOSAL

Chemical Waste Management of the Northwest, Inc., ORD089452353, has received the following waste material:

GENERATOR:	PORT OF TACOMA
MANIFEST #:	011880750JJK
CWM TRACKING ID:	42784701
PROFILE #:	OR321468
LINE ITEM:	9b.1
QUANTITY:	1 DT
RECEIVED DATE:	09/06/13
DISPOSAL PROCESS(ES):	LANDFILL
FINAL DISPOSAL LOCATION:	LANDFILL 13
DISPOSAL DATE:	09/06/13

I certify, on behalf of the above listed treatment facility, that to the best of my knowledge, the above-described waste material was managed in compliance with all applicable laws, regulations, permits and licenses on the date listed above.

Bobbi Jo Galvin

CWMNW RECORDS DEPARTMENT

Date: 09/16/13



CHEMICAL WASTE MANAGEMENT OF THE NW

17629 Cedar Springs Lane
Arlington, OR 97812
(541) 454-2643
(541) 454-3279 Fax

PORT OF TACOMA
WAD001882984
3400 TAYLOR WAY
TACOMA WA 98421

CERTIFICATE OF DISPOSAL

Chemical Waste Management of the Northwest, Inc., ORD089452353, has received the following waste material:

GENERATOR: PORT OF TACOMA
MANIFEST #: 011880745JJK
CWM TRACKING ID: 42785001
PROFILE #: OR321468
LINE ITEM: 9b.1
QUANTITY: 1 DT
RECEIVED DATE: 09/06/13

DISPOSAL PROCESS(ES): LANDFILL
FINAL DISPOSAL LOCATION: LANDFILL 13
DISPOSAL DATE: 09/06/13

I certify, on behalf of the above listed treatment facility, that to the best of my knowledge, the above-described waste material was managed in compliance with all applicable laws, regulations, permits and licenses on the date listed above.

Robbi J Galvin

CWMNW RECORDS DEPARTMENT

Date: 09/16/13



CHEMICAL WASTE MANAGEMENT OF THE NW

17629 Cedar Springs Lane
Arlington, OR 97812
(541) 454-2643
(541) 454-3279 Fax

PORT OF TACOMA
WAD001882984
3400 TAYLOR WAY
TACOMA WA 98421

CERTIFICATE OF DISPOSAL

Chemical Waste Management of the Northwest, Inc., ORD089452353, has received the following waste material:

GENERATOR: PORT OF TACOMA
MANIFEST #: 011880744JJK
CWM TRACKING ID: 42785101
PROFILE #: OR321468
LINE ITEM: 9b.1
QUANTITY: 1 DT
RECEIVED DATE: 09/06/13

DISPOSAL PROCESS(ES): LANDFILL
FINAL DISPOSAL LOCATION: LANDFILL 13
DISPOSAL DATE: 09/06/13

I certify, on behalf of the above listed treatment facility, that to the best of my knowledge, the above-described waste material was managed in compliance with all applicable laws, regulations, permits and licenses on the date listed above.



CWMNW RECORDS DEPARTMENT

Date: 09/16/13



CHEMICAL WASTE MANAGEMENT OF THE NW

17629 Cedar Springs Lane
Arlington, OR 97812
(541) 454-2643
(541) 454-3279 Fax

PORT OF TACOMA
WAD001882984
3400 TAYLOR WAY
TACOMA WA 98421

CERTIFICATE OF DISPOSAL

Chemical Waste Management of the Northwest, Inc., ORD089452353, has received the following waste material:

GENERATOR:	PORT OF TACOMA
MANIFEST #:	011880749JJK
CWM TRACKING ID:	42785201
PROFILE #:	OR321468
LINE ITEM:	9b.1
QUANTITY:	1 DT
RECEIVED DATE:	09/06/13
DISPOSAL PROCESS(ES):	LANDFILL
FINAL DISPOSAL LOCATION:	LANDFILL 13
DISPOSAL DATE:	09/06/13

I certify, on behalf of the above listed treatment facility, that to the best of my knowledge, the above-described waste material was managed in compliance with all applicable laws, regulations, permits and licenses on the date listed above.

Bobbi Balvin

CWMNW RECORDS DEPARTMENT

Date: 09/16/13



CHEMICAL WASTE MANAGEMENT OF THE NW

17629 Cedar Springs Lane
Arlington, OR 97812
(541) 454-2643
(541) 454-3279 Fax

PORT OF TACOMA
WAD001882984
3400 TAYLOR WAY
TACOMA WA 98421

CERTIFICATE OF DISPOSAL

Chemical Waste Management of the Northwest, Inc., ORD089452353, has received the following waste material:

GENERATOR:	PORT OF TACOMA
MANIFEST #:	011880741JJK
CWM TRACKING ID:	42785401
PROFILE #:	OR321468
LINE ITEM:	9b.1
QUANTITY:	1 DT
RECEIVED DATE:	09/06/13
DISPOSAL PROCESS(ES):	LANDFILL
FINAL DISPOSAL LOCATION:	LANDFILL 13
DISPOSAL DATE:	09/06/13

I certify, on behalf of the above listed treatment facility, that to the best of my knowledge, the above-described waste material was managed in compliance with all applicable laws, regulations, permits and licenses on the date listed above.



CWMNW RECORDS DEPARTMENT
Date: 09/16/13



CHEMICAL WASTE MANAGEMENT OF THE NW

17629 Cedar Springs Lane
Arlington, OR 97812
(541) 454-2643
(541) 454-3279 Fax

PORT OF TACOMA
WAD001882984
3400 TAYLOR WAY
TACOMA WA 98421

CERTIFICATE OF DISPOSAL

Chemical Waste Management of the Northwest, Inc., ORD089452353, has received the following waste material:

GENERATOR:	PORT OF TACOMA
MANIFEST #:	01188742JJK
CWM TRACKING ID:	42785501
PROFILE #:	OR321468
LINE ITEM:	9b.1
QUANTITY:	1 DT
RECEIVED DATE:	09/06/13
DISPOSAL PROCESS(ES):	LANDFILL
FINAL DISPOSAL LOCATION:	LANDFILL 13
DISPOSAL DATE:	09/06/13

I certify, on behalf of the above listed treatment facility, that to the best of my knowledge, the above-described waste material was managed in compliance with all applicable laws, regulations, permits and licenses on the date listed above.

Bobbi Jo Galvin

CWMNW RECORDS DEPARTMENT

Date: 09/16/13



CHEMICAL WASTE MANAGEMENT OF THE NW

17629 Cedar Springs Lane
Arlington, OR 97812
(541) 454-2643
(541) 454-3279 Fax

PORT OF TACOMA
WAD001882984
3400 TAYLOR WAY
TACOMA WA 98421

CERTIFICATE OF DISPOSAL

Chemical Waste Management of the Northwest, Inc., ORD089452353, has received the following waste material:

GENERATOR: PORT OF TACOMA
MANIFEST #: 011880743JJK
CWM TRACKING ID: 42705601
PROFILE #: OR321468
LINE ITEM: 9b.1
QUANTITY: 1 DT
RECEIVED DATE: 09/06/13

DISPOSAL PROCESS(ES): LANDFILL
FINAL DISPOSAL LOCATION: LANDFILL 13
DISPOSAL DATE: 09/06/13

I certify, on behalf of the above listed treatment facility, that to the best of my knowledge, the above-described waste material was managed in compliance with all applicable laws, regulations, permits and licenses on the date listed above.

Bobbi Jo Balwin

CWMNW RECORDS DEPARTMENT

Date: 09/16/13



CHEMICAL WASTE MANAGEMENT OF THE NW

17629 Cedar Springs Lane
Arlington, OR 97812
(541) 454-2643
(541) 454-3279 Fax

PORT OF TACOMA
WAD001882984
3400 TAYLOR WAY
TACOMA WA 98421

CERTIFICATE OF DISPOSAL

Chemical Waste Management of the Northwest, Inc., ORD089452353, has received the following waste material:

GENERATOR:	PORT OF TACOMA
MANIFEST #:	011880736JJK
CWM TRACKING ID:	42785801
PROFILE #:	OR321468
LINE ITEM:	9b.1
QUANTITY:	1 DT
RECEIVED DATE:	09/06/13
DISPOSAL PROCESS(ES):	LANDFILL
FINAL DISPOSAL LOCATION:	LANDFILL 13
DISPOSAL DATE:	09/06/13

I certify, on behalf of the above listed treatment facility, that to the best of my knowledge, the above-described waste material was managed in compliance with all applicable laws, regulations, permits and licenses on the date listed above.



CWMNW RECORDS DEPARTMENT

Date: 09/16/13



CHEMICAL WASTE MANAGEMENT OF THE NW

17629 Cedar Springs Lane
Arlington, OR 97812
(541) 454-2643
(541) 454-3279 Fax

PORT OF TACOMA
WAD001882984
3400 TAYLOR WAY
TACOMA WA 98421

CERTIFICATE OF DISPOSAL

Chemical Waste Management of the Northwest, Inc., ORD089452353, has received the following waste material:

GENERATOR:	PORT OF TACOMA
MANIFEST #:	011880740JJK
CWM TRACKING ID:	42786501
PROFILE #:	OR321468
LINE ITEM:	9b.1
QUANTITY:	1 DT
RECEIVED DATE:	09/06/13
DISPOSAL PROCESS(ES):	LANDFILL
FINAL DISPOSAL LOCATION:	LANDFILL 13
DISPOSAL DATE:	09/06/13

I certify, on behalf of the above listed treatment facility, that to the best of my knowledge, the above-described waste material was managed in compliance with all applicable laws, regulations, permits and licenses on the date listed above.

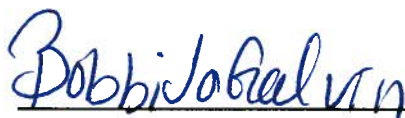

CWMNW RECORDS DEPARTMENT

Date:

09/16/13



CHEMICAL WASTE MANAGEMENT OF THE NW

17629 Cedar Springs Lane
Arlington, OR 97812
(541) 454-2643
(541) 454-3279 Fax

PORT OF TACOMA
WAD001882984
3400 TAYLOR WAY
TACOMA WA 98421

CERTIFICATE OF DISPOSAL

Chemical Waste Management of the Northwest, Inc., ORD089452353, has received the following waste material:

GENERATOR: PORT OF TACOMA
MANIFEST #: 011880737JJK
CWM TRACKING ID: 42786601
PROFILE #: OR321468
LINE ITEM: 9b.1
QUANTITY: 1 DT
RECEIVED DATE: 09/06/13

DISPOSAL PROCESS(ES): LANDFILL
FINAL DISPOSAL LOCATION: LANDFILL 13
DISPOSAL DATE: 09/06/13

I certify, on behalf of the above listed treatment facility, that to the best of my knowledge, the above-described waste material was managed in compliance with all applicable laws, regulations, permits and licenses on the date listed above.

Robbino Galvin

CWMNW RECORDS DEPARTMENT

Date: 09/16/13



CHEMICAL WASTE MANAGEMENT OF THE NW

17629 Cedar Springs Lane
Arlington, OR 97812
(541) 454-2643
(541) 454-3279 Fax

PORT OF TACOMA
WAD001882984
3400 TAYLOR WAY
TACOMA WA 98421

CERTIFICATE OF DISPOSAL

Chemical Waste Management of the Northwest, Inc., ORD089452353, has received the following waste material:

GENERATOR:	PORT OF TACOMA
MANIFEST #:	011080739JJK
CWM TRACKING ID:	42786701
PROFILE #:	OR321468
LINE ITEM:	9b.1
QUANTITY:	1 DT
RECEIVED DATE:	09/06/13
DISPOSAL PROCESS(ES):	LANDFILL
FINAL DISPOSAL LOCATION:	LANDFILL 13
DISPOSAL DATE:	09/06/13

I certify, on behalf of the above listed treatment facility, that to the best of my knowledge, the above-described waste material was managed in compliance with all applicable laws, regulations, permits and licenses on the date listed above.

Bobbi Jo Galum

CWMNW RECORDS DEPARTMENT

Date: 09/16/13



CHEMICAL WASTE MANAGEMENT OF THE NW

17629 Cedar Springs Lane
Arlington, OR 97812
(541) 454-2643
(541) 454-3279 Fax

PORT OF TACOMA
WAD001882984
3400 TAYLOR WAY
TACOMA WA 98421

CERTIFICATE OF DISPOSAL

Chemical Waste Management of the Northwest, Inc., ORD089452353, has received the following waste material:

GENERATOR:	PORT OF TACOMA
MANIFEST #:	011880738JJK
CWM TRACKING ID:	42786801
PROFILE #:	OR321468
LINE ITEM:	9b.1
QUANTITY:	1 DT
RECEIVED DATE:	09/06/13
DISPOSAL PROCESS(ES):	LANDFILL
FINAL DISPOSAL LOCATION:	LANDFILL 13
DISPOSAL DATE:	09/03/13

I certify, on behalf of the above listed treatment facility, that to the best of my knowledge, the above-described waste material was managed in compliance with all applicable laws, regulations, permits and licenses on the date listed above.

Bobbi Jo Galvin

CWMNW RECORDS DEPARTMENT

Date: 09/16/13



CHEMICAL WASTE MANAGEMENT OF THE NW

17629 Cedar Springs Lane
Arlington, OR 97812
(541) 454-2643
(541) 454-3279 Fax

PORT OF TACOMA
WAD001882984
3400 TAYLOR WAY
TACOMA WA 98421

CERTIFICATE OF DISPOSAL

Chemical Waste Management of the Northwest, Inc., ORD089452353, has received the following waste material:

GENERATOR:	PORT OF TACOMA
MANIFEST #:	011880734JJK
CWM TRACKING ID:	42787101
PROFILE #:	OR321468
LINE ITEM:	9b.1
QUANTITY:	1 DT
RECEIVED DATE:	09/06/13
DISPOSAL PROCESS(ES):	LANDFILL
FINAL DISPOSAL LOCATION:	LANDFILL 13
DISPOSAL DATE:	09/06/13

I certify, on behalf of the above listed treatment facility, that to the best of my knowledge, the above-described waste material was managed in compliance with all applicable laws, regulations, permits and licenses on the date listed above.

Bobbi Jo Galvin

CWMNW RECORDS DEPARTMENT
Date:

09/16/13



CHEMICAL WASTE MANAGEMENT OF THE NW

17629 Cedar Springs Lane
Arlington, OR 97812
(541) 454-2643
(541) 454-3279 Fax

PORT OF TACOMA
WAD001882984
3400 TAYLOR WAY
TACOMA WA 98421

CERTIFICATE OF DISPOSAL

Chemical Waste Management of the Northwest, Inc., ORD089452353, has received the following waste material:

GENERATOR:	PORT OF TACOMA
MANIFEST #:	011880732JJK
CWM TRACKING ID:	42787201
PROFILE #:	OR321468
LINE ITEM:	9b.1
QUANTITY:	1 DT
RECEIVED DATE:	09/06/13
DISPOSAL PROCESS(ES):	LANDFILL
FINAL DISPOSAL LOCATION:	LANDFILL 13
DISPOSAL DATE:	09/06/13

I certify, on behalf of the above listed treatment facility, that to the best of my knowledge, the above-described waste material was managed in compliance with all applicable laws, regulations, permits and licenses on the date listed above.

Bobbi Jo Balvin

CWMNW RECORDS DEPARTMENT

Date: 09/16/13



CHEMICAL WASTE MANAGEMENT OF THE NW

17629 Cedar Springs Lane
Arlington, OR 97812
(541) 454-2643
(541) 454-3279 Fax

PORT OF TACOMA
WAD001882984
3400 TAYLOR WAY
TACOMA WA 98421

CERTIFICATE OF DISPOSAL

Chemical Waste Management of the Northwest, Inc., ORD089452353, has received the following waste material:

GENERATOR: PORT OF TACOMA
MANIFEST #: 011880747JJK
CWM TRACKING ID: 42784201
PROFILE #: OR321468
LINE ITEM: 9b.1
QUANTITY: 1 DT
RECEIVED DATE: 09/06/13

DISPOSAL PROCESS(ES): LANDFILL
FINAL DISPOSAL LOCATION: LANDFILL 13
DISPOSAL DATE: 09/06/13

I certify, on behalf of the above listed treatment facility, that to the best of my knowledge, the above-described waste material was managed in compliance with all applicable laws, regulations, permits and licenses on the date listed above.

CWMNW RECORDS DEPARTMENT

Date: 09/13/13



CHEMICAL WASTE MANAGEMENT OF THE NW
17629 Cedar Springs Lane
Arlington, OR 97812
(541) 454-2643
(541) 454-3279 Fax

PORT OF TACOMA
WAD001882984
3400 TAYLOR WAY
TACOMA WA 98421

CERTIFICATE OF DISPOSAL

Chemical Waste Management of the Northwest, Inc., ORD089452353, has received the following waste material:

GENERATOR:	PORT OF TACOMA
MANIFEST #:	011870162JJK
CWM TRACKING ID:	42709201
PROFILE #:	OR321468
LINE ITEM:	9b.1
QUANTITY:	1 DT
RECEIVED DATE:	09/09/13
DISPOSAL PROCESS(ES):	LANDFILL
FINAL DISPOSAL LOCATION:	LANDFILL 13
DISPOSAL DATE:	09/09/13

I certify, on behalf of the above listed treatment facility, that to the best of my knowledge, the above-described waste material was managed in compliance with all applicable laws, regulations, permits and licenses on the date listed above.



CWMNW RECORDS DEPARTMENT
Date: 09/17/13



CHEMICAL WASTE MANAGEMENT OF THE NW

17629 Cedar Springs Lane
Arlington, OR 97812
(541) 454-2643
(541) 454-3279 Fax

PORT OF TACOMA
WAD001882984
3400 TAYLOR WAY
TACOMA WA 98421

CERTIFICATE OF DISPOSAL

Chemical Waste Management of the Northwest, Inc., ORD089452353, has received the following waste material:

GENERATOR:	PORT OF TACOMA
MANIFEST #:	011870163JJK
CWM TRACKING ID:	42789301
PROFILE #:	OR321468
LINE ITEM:	9b.1
QUANTITY:	1 DT
RECEIVED DATE:	09/09/13
DISPOSAL PROCESS(ES):	LANDFILL
FINAL DISPOSAL LOCATION:	LANDFILL 13
DISPOSAL DATE:	09/09/13

I certify, on behalf of the above listed treatment facility, that to the best of my knowledge, the above-described waste material was managed in compliance with all applicable laws, regulations, permits and licenses on the date listed above.



CWMNW RECORDS DEPARTMENT

Date: 09/17/13



CHEMICAL WASTE MANAGEMENT OF THE NW

17629 Cedar Springs Lane
Arlington, OR 97812
(541) 454-2643
(541) 454-3279 Fax

PORT OF TACOMA
WAD001882984
3400 TAYLOR WAY
TACOMA WA 98421

CERTIFICATE OF DISPOSAL

Chemical Waste Management of the Northwest, Inc., ORD089452353, has received the following waste material:

GENERATOR:	PORT OF TACOMA
MANIFEST #:	011870161JJK
CWM TRACKING ID:	42789401
PROFILE #:	OR321468
LINE ITEM:	9b.1
QUANTITY:	1 DT
RECEIVED DATE:	09/09/13
DISPOSAL PROCESS(ES):	LANDFILL
FINAL DISPOSAL LOCATION:	LANDFILL 13
DISPOSAL DATE:	09/09/13

I certify, on behalf of the above listed treatment facility, that to the best of my knowledge, the above-described waste material was managed in compliance with all applicable laws, regulations, permits and licenses on the date listed above.

Bobbi Jo Graham

CWMNW RECORDS DEPARTMENT

Date: 09/17/13



CHEMICAL WASTE MANAGEMENT OF THE NW

17629 Cedar Springs Lane
Arlington, OR 97812
(541) 454-2643
(541) 454-3279 Fax

PORT OF TACOMA
WAD001882984
3400 TAYLOR WAY
TACOMA WA 98421

CERTIFICATE OF DISPOSAL

Chemical Waste Management of the Northwest, Inc., ORD089452353, has received the following waste material:

GENERATOR:	PORT OF TACOMA
MANIFEST #:	011880729JJK
CWM TRACKING ID:	42789601
PROFILE #:	OR321468
LINE ITEM:	9b.1
QUANTITY:	1 DT
RECEIVED DATE:	09/09/13
DISPOSAL PROCESS(ES):	LANDFILL
FINAL DISPOSAL LOCATION:	LANDFILL 13
DISPOSAL DATE:	09/09/13

I certify, on behalf of the above listed treatment facility, that to the best of my knowledge, the above-described waste material was managed in compliance with all applicable laws, regulations, permits and licenses on the date listed above.



CWMNW RECORDS DEPARTMENT

Date: 09/17/13



CHEMICAL WASTE MANAGEMENT OF THE NW

17629 Cedar Springs Lane
Arlington, OR 97812
(541) 454-2643
(541) 454-3279 Fax

PORT OF TACOMA
WAD001882984
3400 TAYLOR WAY
TACOMA WA 98421

CERTIFICATE OF DISPOSAL

Chemical Waste Management of the Northwest, Inc., ORD089452353, has received the following waste material:

GENERATOR:	PORT OF TACOMA
MANIFEST #:	011870167JJK
CWM TRACKING ID:	42789701
PROFILE #:	OR321468
LINE ITEM:	9b.1
QUANTITY:	1 DT
RECEIVED DATE:	09/09/13
DISPOSAL PROCESS(ES):	LANDFILL
FINAL DISPOSAL LOCATION:	LANDFILL 13
DISPOSAL DATE:	09/09/13

I certify, on behalf of the above listed treatment facility, that to the best of my knowledge, the above-described waste material was managed in compliance with all applicable laws, regulations, permits and licenses on the date listed above.



CWMNW RECORDS DEPARTMENT

Date: 09/17/13



CHEMICAL WASTE MANAGEMENT OF THE NW

17629 Cedar Springs Lane
Arlington, OR 97812
(541) 454-2643
(541) 454-3279 Fax

PORT OF TACOMA
WAD001882984
3400 TAYLOR WAY
TACOMA WA 98421

CERTIFICATE OF DISPOSAL

Chemical Waste Management of the Northwest, Inc., ORD089452353, has received the following waste material:

GENERATOR:	PORT OF TACOMA
MANIFEST #:	011880727JJK
CWM TRACKING ID:	42789801
PROFILE #:	OR321468
LINE ITEM:	9b.1
QUANTITY:	1 DT
RECEIVED DATE:	09/09/13
DISPOSAL PROCESS(ES):	LANDFILL
FINAL DISPOSAL LOCATION:	LANDFILL 13
DISPOSAL DATE:	09/09/13

I certify, on behalf of the above listed treatment facility, that to the best of my knowledge, the above-described waste material was managed in compliance with all applicable laws, regulations, permits and licenses on the date listed above.

Robbido Galvin

CWMNW RECORDS DEPARTMENT

Date: 09/17/13



CHEMICAL WASTE MANAGEMENT OF THE NW

17629 Cedar Springs Lane
Arlington, OR 97812
(541) 454-2643
(541) 454-3279 Fax

PORT OF TACOMA
WAD001882984
3400 TAYLOR WAY
TACOMA WA 98421

CERTIFICATE OF DISPOSAL

Chemical Waste Management of the Northwest, Inc., ORD089452353, has received the following waste material:

GENERATOR:	PORT OF TACOMA
MANIFEST #:	011870109JJK
CWM TRACKING ID:	42789901
PROFILE #:	OR321468
LINE ITEM:	9b.1
QUANTITY:	1 DT
RECEIVED DATE:	09/09/13
DISPOSAL PROCESS(ES):	LANDFILL
FINAL DISPOSAL LOCATION:	LANDFILL 13
DISPOSAL DATE:	09/09/13

I certify, on behalf of the above listed treatment facility, that to the best of my knowledge, the above-described waste material was managed in compliance with all applicable laws, regulations, permits and licenses on the date listed above.

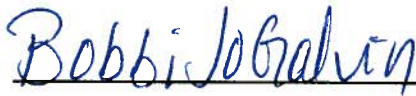

CWMNW RECORDS DEPARTMENT

Date: 09/17/13



CHEMICAL WASTE MANAGEMENT OF THE NW

17629 Cedar Springs Lane
Arlington, OR 97812
(541) 454-2643
(541) 454-3279 Fax

PORT OF TACOMA
WAD001882984
3400 TAYLOR WAY
TACOMA WA 98421

CERTIFICATE OF DISPOSAL

Chemical Waste Management of the Northwest, Inc., ORD089452353, has received the following waste material:

GENERATOR:	PORT OF TACOMA
MANIFEST #:	011870166JJK
CWM TRACKING ID:	42790001
PROFILE #:	OR321468
LINE ITEM:	9b.1
QUANTITY:	1 DT
RECEIVED DATE:	09/09/13
DISPOSAL PROCESS(ES):	LANDFILL
FINAL DISPOSAL LOCATION:	LANDFILL 13
DISPOSAL DATE:	09/09/13

I certify, on behalf of the above listed treatment facility, that to the best of my knowledge, the above-described waste material was managed in compliance with all applicable laws, regulations, permits and licenses on the date listed above.

Robbido Balvin

CWMNW RECORDS DEPARTMENT

Date: 09/17/13



CHEMICAL WASTE MANAGEMENT OF THE NW

17629 Cedar Springs Lane
Arlington, OR 97812
(541) 454-2643
(541) 454-3279 Fax

PORT OF TACOMA
WAD001882984
3400 TAYLOR WAY
TACOMA WA 98421

CERTIFICATE OF DISPOSAL

Chemical Waste Management of the Northwest, Inc., ORD089452353, has received the following waste material:

GENERATOR:	PORT OF TACOMA
MANIFEST #:	011880728JJK
CWM TRACKING ID:	42790101
PROFILE #:	OR321468
LINE ITEM:	9b.1
QUANTITY:	1 DT
RECEIVED DATE:	09/09/13
DISPOSAL PROCESS(ES):	LANDFILL
FINAL DISPOSAL LOCATION:	LANDFILL 13
DISPOSAL DATE:	09/09/13

I certify, on behalf of the above listed treatment facility, that to the best of my knowledge, the above-described waste material was managed in compliance with all applicable laws, regulations, permits and licenses on the date listed above.

Bobbi Jo Galvin

CWMNW RECORDS DEPARTMENT

Date: 09/17/13



CHEMICAL WASTE MANAGEMENT OF THE NW

17629 Cedar Springs Lane
Arlington, OR 97812
(541) 454-2643
(541) 454-3279 Fax

PORT OF TACOMA
WAD001882984
3400 TAYLOR WAY
TACOMA WA 98421

CERTIFICATE OF DISPOSAL

Chemical Waste Management of the Northwest, Inc., ORD089452353, has received the following waste material:

GENERATOR:	PORT OF TACOMA
MANIFEST #:	011870168JJK
CWM TRACKING ID:	42790701
PROFILE #:	OR321468
LINE ITEM:	9b.1
QUANTITY:	1 DT
RECEIVED DATE:	09/09/13
DISPOSAL PROCESS(ES):	LANDFILL
FINAL DISPOSAL LOCATION:	LANDFILL 13
DISPOSAL DATE:	09/09/13

I certify, on behalf of the above listed treatment facility, that to the best of my knowledge, the above-described waste material was managed in compliance with all applicable laws, regulations, permits and licenses on the date listed above.

Robbi Jo Galvin

CWMNW RECORDS DEPARTMENT

Date: 09/17/13



CHEMICAL WASTE MANAGEMENT OF THE NW

17629 Cedar Springs Lane
Arlington, OR 97812
(541) 454-2643
(541) 454-3279 Fax

PORT OF TACOMA
WAD001882984
3400 TAYLOR WAY
TACOMA WA 98421

CERTIFICATE OF DISPOSAL

Chemical Waste Management of the Northwest, Inc., ORD089452353, has received the following waste material:

GENERATOR:	PORT OF TACOMA
MANIFEST #:	011880730JJK
CWM TRACKING ID:	42790901
PROFILE #:	OR321468
LINE ITEM:	9b.1
QUANTITY:	1 DT
RECEIVED DATE:	09/09/13
DISPOSAL PROCESS(ES):	LANDFILL
FINAL DISPOSAL LOCATION:	LANDFILL 13
DISPOSAL DATE:	09/09/13

I certify, on behalf of the above listed treatment facility, that to the best of my knowledge, the above-described waste material was managed in compliance with all applicable laws, regulations, permits and licenses on the date listed above.

Bobbi Gralvin

CWMNW RECORDS DEPARTMENT

Date: 09/17/13



CHEMICAL WASTE MANAGEMENT OF THE NW

17629 Cedar Springs Lane
Arlington, OR 97812
(541) 454-2643
(541) 454-3279 Fax

PORT OF TACOMA
WAD001882984
3400 TAYLOR WAY
TACOMA WA 98421

CERTIFICATE OF DISPOSAL

Chemical Waste Management of the Northwest, Inc., ORD089452353, has received the following waste material:

GENERATOR:	PORT OF TACOMA
MANIFEST #:	011870164JJK
CWM TRACKING ID:	42791001
PROFILE #:	OR321468
LINE ITEM:	9b.1
QUANTITY:	1 DT
RECEIVED DATE:	09/09/13
DISPOSAL PROCESS(ES):	LANDFILL
FINAL DISPOSAL LOCATION:	LANDFILL 13
DISPOSAL DATE:	09/09/13

I certify, on behalf of the above listed treatment facility, that to the best of my knowledge, the above-described waste material was managed in compliance with all applicable laws, regulations, permits and licenses on the date listed above.



CWMNW RECORDS DEPARTMENT

Date: 09/17/13



CHEMICAL WASTE MANAGEMENT OF THE NW

17629 Cedar Springs Lane
Arlington, OR 97812
(541) 454-2643
(541) 454-3279 Fax

PORT OF TACOMA
WAD001882984
3400 TAYLOR WAY
TACOMA WA 98421

CERTIFICATE OF DISPOSAL

Chemical Waste Management of the Northwest, Inc., ORD089452353, has received the following waste material:

GENERATOR:	PORT OF TACOMA
MANIFEST #:	011870171JJK
CWM TRACKING ID:	42791101
PROFILE #:	OR321468
LINE ITEM:	9b.1
QUANTITY:	1 DT
RECEIVED DATE:	09/09/13
DISPOSAL PROCESS(ES):	LANDFILL
FINAL DISPOSAL LOCATION:	LANDFILL 13
DISPOSAL DATE:	09/09/13

I certify, on behalf of the above listed treatment facility, that to the best of my knowledge, the above-described waste material was managed in compliance with all applicable laws, regulations, permits and licenses on the date listed above.



CWMNW RECORDS DEPARTMENT

Date: 09/17/13



CHEMICAL WASTE MANAGEMENT OF THE NW

17629 Cedar Springs Lane
Arlington, OR 97812
(541) 454-2643
(541) 454-3279 Fax

PORT OF TACOMA
WAD001882984
3400 TAYLOR WAY
TACOMA WA 98421

CERTIFICATE OF DISPOSAL

Chemical Waste Management of the Northwest, Inc., ORD089452353, has received the following waste material:

GENERATOR:	PORT OF TACOMA
MANIFEST #:	011870103JJK
CWM TRACKING ID:	42791201
PROFILE #:	OR321468
LINE ITEM:	9b.1
QUANTITY:	1 DT
RECEIVED DATE:	09/09/13
DISPOSAL PROCESS(ES):	LANDFILL
FINAL DISPOSAL LOCATION:	LANDFILL 13
DISPOSAL DATE:	09/09/13

I certify, on behalf of the above listed treatment facility, that to the best of my knowledge, the above-described waste material was managed in compliance with all applicable laws, regulations, permits and licenses on the date listed above.



CWMNW RECORDS DEPARTMENT

Date: 09/17/13



CHEMICAL WASTE MANAGEMENT OF THE NW

17629 Cedar Springs Lane
Arlington, OR 97812
(541) 454-2643
(541) 454-3279 Fax

PORT OF TACOMA
WAD001882984
3400 TAYLOR WAY
TACOMA WA 98421

CERTIFICATE OF DISPOSAL

Chemical Waste Management of the Northwest, Inc., ORD089452353, has received the following waste material:

GENERATOR:	PORT OF TACOMA
MANIFEST #:	011870172JJK
CWM TRACKING ID:	42791301
PROFILE #:	OR321468
LINE ITEM:	9b.1
QUANTITY:	1 DT
RECEIVED DATE:	09/09/13
DISPOSAL PROCESS(ES):	LANDFILL
FINAL DISPOSAL LOCATION:	LANDFILL 13
DISPOSAL DATE:	09/09/13

I certify, on behalf of the above listed treatment facility, that to the best of my knowledge, the above-described waste material was managed in compliance with all applicable laws, regulations, permits and licenses on the date listed above.



CWMNW RECORDS DEPARTMENT

Date: 09/17/13



CHEMICAL WASTE MANAGEMENT OF THE NW

17629 Cedar Springs Lane
Arlington, OR 97812
(541) 454-2643
(541) 454-3279 Fax

PORT OF TACOMA
WAD001882984
3400 TAYLOR WAY
TACOMA WA 98421

CERTIFICATE OF DISPOSAL

Chemical Waste Management of the Northwest, Inc., ORD089452353, has received the following waste material:

GENERATOR:	PORT OF TACOMA
MANIFEST #:	011870108JJK
CWM TRACKING ID:	42791401
PROFILE #:	OR321468
LINE ITEM:	9b.1
QUANTITY:	1 DT
RECEIVED DATE:	09/09/13
DISPOSAL PROCESS(ES):	LANDFILL
FINAL DISPOSAL LOCATION:	LANDFILL 13
DISPOSAL DATE:	09/09/13

I certify, on behalf of the above listed treatment facility, that to the best of my knowledge, the above-described waste material was managed in compliance with all applicable laws, regulations, permits and licenses on the date listed above.

Bobbi Bradwin

CWMNW RECORDS DEPARTMENT

Date: 09/17/13



CHEMICAL WASTE MANAGEMENT OF THE NW
17629 Cedar Springs Lane
Arlington, OR 97812
(541) 454-2643
(541) 454-3279 Fax

PORT OF TACOMA
WAD001882984
3400 TAYLOR WAY
TACOMA WA 98421

CERTIFICATE OF DISPOSAL

Chemical Waste Management of the Northwest, Inc., ORD089452353, has received the following waste material:

GENERATOR:	PORT OF TACOMA
MANIFEST #:	011870165JJK
CWM TRACKING ID:	42791601
PROFILE #:	OR321468
LINE ITEM:	9b.1
QUANTITY:	1 DT
RECEIVED DATE:	09/09/13
DISPOSAL PROCESS(ES):	LANDFILL
FINAL DISPOSAL LOCATION:	LANDFILL 13
DISPOSAL DATE:	09/09/13

I certify, on behalf of the above listed treatment facility, that to the best of my knowledge, the above-described waste material was managed in compliance with all applicable laws, regulations, permits and licenses on the date listed above.

Robbi Jobst

CWMNW RECORDS DEPARTMENT

Date: 09/17/13



CHEMICAL WASTE MANAGEMENT OF THE NW

17629 Cedar Springs Lane
Arlington, OR 97812
(541) 454-2643
(541) 454-3279 Fax

PORT OF TACOMA
WAD001882984
3400 TAYLOR WAY
TACOMA WA 98421

CERTIFICATE OF DISPOSAL

Chemical Waste Management of the Northwest, Inc., ORD089452353, has received the following waste material:

GENERATOR:	PORT OF TACOMA
MANIFEST #:	011870170JJK
CWM TRACKING ID:	42791801
PROFILE #:	OR321468
LINE ITEM:	9b.1
QUANTITY:	1 DT
RECEIVED DATE:	09/09/13
DISPOSAL PROCESS(ES):	LANDFILL
FINAL DISPOSAL LOCATION:	LANDFILL 13
DISPOSAL DATE:	09/09/13

I certify, on behalf of the above listed treatment facility, that to the best of my knowledge, the above-described waste material was managed in compliance with all applicable laws, regulations, permits and licenses on the date listed above.



CWMNW RECORDS DEPARTMENT

Date: 09/17/13



CHEMICAL WASTE MANAGEMENT OF THE NW

17629 Cedar Springs Lane
Arlington, OR 97812
(541) 454-2643
(541) 454-3279 Fax

PORT OF TACOMA
WAD001882984
3400 TAYLOR WAY
TACOMA WA 98421

CERTIFICATE OF DISPOSAL

Chemical Waste Management of the Northwest, Inc., ORD089452353, has received the following waste material:

GENERATOR:	PORT OF TACOMA
MANIFEST #:	011870107JJK
CWM TRACKING ID:	42792001
PROFILE #:	OR321468
LINE ITEM:	9b.1
QUANTITY:	1 DT
RECEIVED DATE:	09/09/13
DISPOSAL PROCESS(ES):	LANDFILL
FINAL DISPOSAL LOCATION:	LANDFILL 13
DISPOSAL DATE:	09/09/13

I certify, on behalf of the above listed treatment facility, that to the best of my knowledge, the above-described waste material was managed in compliance with all applicable laws, regulations, permits and licenses on the date listed above.

Bobbi Jo Galvin

CWMNW RECORDS DEPARTMENT

Date: 09/17/13



CHEMICAL WASTE MANAGEMENT OF THE NW
17629 Cedar Springs Lane
Arlington, OR 97812
(541) 454-2643
(541) 454-3279 Fax

PORT OF TACOMA
WAD001882984
3400 TAYLOR WAY
TACOMA WA 98421

CERTIFICATE OF DISPOSAL

Chemical Waste Management of the Northwest, Inc., ORD089452353, has received the following waste material:

GENERATOR:	PORT OF TACOMA
MANIFEST #:	011870106JJK
CWM TRACKING ID:	42792201
PROFILE #:	OR321468
LINE ITEM:	9b.1
QUANTITY:	1 DT
RECEIVED DATE:	09/09/13
DISPOSAL PROCESS(ES):	LANDFILL
FINAL DISPOSAL LOCATION:	LANDFILL 13
DISPOSAL DATE:	09/09/13

I certify, on behalf of the above listed treatment facility, that to the best of my knowledge, the above-described waste material was managed in compliance with all applicable laws, regulations, permits and licenses on the date listed above.

Robbido Galvin

CWMNW RECORDS DEPARTMENT

Date: 09/17/13



CHEMICAL WASTE MANAGEMENT OF THE NW
17629 Cedar Springs Lane
Arlington, OR 97812
(541) 454-2643
(541) 454-3279 Fax

PORT OF TACOMA
WAD001882984
3400 TAYLOR WAY
TACOMA WA 98421

CERTIFICATE OF DISPOSAL

Chemical Waste Management of the Northwest, Inc., ORD089452353, has received the following waste material:

GENERATOR:	PORT OF TACOMA
MANIFEST #:	011870105JJK
CWM TRACKING ID:	42792301
PROFILE #:	OR321468
LINE ITEM:	9b.1
QUANTITY:	1 DT
RECEIVED DATE:	09/09/13
DISPOSAL PROCESS(ES):	LANDFILL
FINAL DISPOSAL LOCATION:	LANDFILL 13
DISPOSAL DATE:	09/09/13

I certify, on behalf of the above listed treatment facility, that to the best of my knowledge, the above-described waste material was managed in compliance with all applicable laws, regulations, permits and licenses on the date listed above.

Robb G. Galvin

CWMNW RECORDS DEPARTMENT

Date: 09/17/13



CHEMICAL WASTE MANAGEMENT OF THE NW

17629 Cedar Springs Lane
Arlington, OR 97812
(541) 454-2643
(541) 454-3279 Fax

PORT OF TACOMA
WAD001882984
3400 TAYLOR WAY
TACOMA WA 98421

CERTIFICATE OF DISPOSAL

Chemical Waste Management of the Northwest, Inc., ORD089452353, has received the following waste material:

GENERATOR:	PORT OF TACOMA
MANIFEST #:	011870102JJK
CWM TRACKING ID:	42792401
PROFILE #:	OR321468
LINE ITEM:	9b.1
QUANTITY:	1 DT
RECEIVED DATE:	09/09/13
DISPOSAL PROCESS(ES):	LANDFILL
FINAL DISPOSAL LOCATION:	LANDFILL 13
DISPOSAL DATE:	09/09/13

I certify, on behalf of the above listed treatment facility, that to the best of my knowledge, the above-described waste material was managed in compliance with all applicable laws, regulations, permits and licenses on the date listed above.



CWMNW RECORDS DEPARTMENT

Date: 09/17/13



CHEMICAL WASTE MANAGEMENT OF THE NW
17629 Cedar Springs Lane
Arlington, OR 97812
(541) 454-2643
(541) 454-3279 Fax

PORT OF TACOMA
WAD001882984
3400 TAYLOR WAY
TACOMA WA 98421

CERTIFICATE OF DISPOSAL

Chemical Waste Management of the Northwest, Inc., ORD089452353, has received the following waste material:

GENERATOR:	PORT OF TACOMA
MANIFEST #:	011870169JJK
CWM TRACKING ID:	427915-01
PROFILE #:	OR321468
LINE ITEM:	9b.1
QUANTITY:	1 DT
RECEIVED DATE:	09/09/13
DISPOSAL PROCESS(ES):	LANDFILL
FINAL DISPOSAL LOCATION:	LANDFILL 13
DISPOSAL DATE:	09/09/13

I certify, on behalf of the above listed treatment facility, that to the best of my knowledge, the above-described waste material was managed in compliance with all applicable laws, regulations, permits and licenses on the date listed above.



CWMNW RECORDS DEPARTMENT

Date: 09/18/13



CHEMICAL WASTE MANAGEMENT OF THE NW

17629 Cedar Springs Lane
Arlington, OR 97812
(541) 454-2643
(541) 454-3279 Fax

PORT OF TACOMA
WAD001882984
3400 TAYLOR WAY
TACOMA WA 98421

CERTIFICATE OF DISPOSAL

Chemical Waste Management of the Northwest, Inc., ORD089452353, has received the following waste material:

GENERATOR:	PORT OF TACOMA
MANIFEST #:	011870100JJK
CWM TRACKING ID:	427940-01
PROFILE #:	OR321468
LINE ITEM:	9b.1
QUANTITY:	1 DT
RECEIVED DATE:	09/10/13
DISPOSAL PROCESS(ES):	LANDFILL
FINAL DISPOSAL LOCATION:	LANDFILL 13
DISPOSAL DATE:	09/10/13

I certify, on behalf of the above listed treatment facility, that to the best of my knowledge, the above-described waste material was managed in compliance with all applicable laws, regulations, permits and licenses on the date listed above.



CWMNW RECORDS DEPARTMENT

Date: 09/18/13



CHEMICAL WASTE MANAGEMENT OF THE NW

17629 Cedar Springs Lane
Arlington, OR 97812
(541) 454-2643
(541) 454-3279 Fax

PORT OF TACOMA
WAD001882984
3400 TAYLOR WAY
TACOMA WA 98421

CERTIFICATE OF DISPOSAL

Chemical Waste Management of the Northwest, Inc., ORD089452353, has received the following waste material:

GENERATOR:	PORT OF TACOMA
MANIFEST #:	011870094JJK
CWM TRACKING ID:	427944-01
PROFILE #:	OR321468
LINE ITEM:	9b.1
QUANTITY:	1 DT
RECEIVED DATE:	09/10/13
DISPOSAL PROCESS(ES):	LANDFILL
FINAL DISPOSAL LOCATION:	LANDFILL 13
DISPOSAL DATE:	09/10/13

I certify, on behalf of the above listed treatment facility, that to the best of my knowledge, the above-described waste material was managed in compliance with all applicable laws, regulations, permits and licenses on the date listed above.

Becky Sumner

CWMNW RECORDS DEPARTMENT

Date: 09/18/13



CHEMICAL WASTE MANAGEMENT OF THE NW

17629 Cedar Springs Lane
Arlington, OR 97812
(541) 454-2643
(541) 454-3279 Fax

PORT OF TACOMA
WAD001882984
3400 TAYLOR WAY
TACOMA WA 98421

CERTIFICATE OF DISPOSAL

Chemical Waste Management of the Northwest, Inc., ORD089452353, has received the following waste material:

GENERATOR:	PORT OF TACOMA
MANIFEST #:	011870093JJK
CWM TRACKING ID:	427946-01
PROFILE #:	OR321468
LINE ITEM:	9b.1
QUANTITY:	1 DT
RECEIVED DATE:	09/10/13
DISPOSAL PROCESS(ES):	LANDFILL
FINAL DISPOSAL LOCATION:	LANDFILL 13
DISPOSAL DATE:	09/10/13

I certify, on behalf of the above listed treatment facility, that to the best of my knowledge, the above-described waste material was managed in compliance with all applicable laws, regulations, permits and licenses on the date listed above.

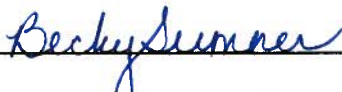

CWMNW RECORDS DEPARTMENT

Date: 09/18/13



CHEMICAL WASTE MANAGEMENT OF THE NW

17629 Cedar Springs Lane
Arlington, OR 97812
(541) 454-2643
(541) 454-3279 Fax

PORT OF TACOMA
WAD001882984
3400 TAYLOR WAY
TACOMA WA 98421

CERTIFICATE OF DISPOSAL

Chemical Waste Management of the Northwest, Inc., ORD089452353, has received the following waste material:

GENERATOR:	PORT OF TACOMA
MANIFEST #:	011870096JJK
CWM TRACKING ID:	427947-01
PROFILE #:	OR321468
LINE ITEM:	9b.1
QUANTITY:	1 DT
RECEIVED DATE:	09/10/13
DISPOSAL PROCESS(ES):	LANDFILL
FINAL DISPOSAL LOCATION:	LANDFILL 13
DISPOSAL DATE:	09/10/13

I certify, on behalf of the above listed treatment facility, that to the best of my knowledge, the above-described waste material was managed in compliance with all applicable laws, regulations, permits and licenses on the date listed above.

Becky Sumner

CWMNW RECORDS DEPARTMENT

Date: 09/18/13



CHEMICAL WASTE MANAGEMENT OF THE NW

17629 Cedar Springs Lane
Arlington, OR 97812
(541) 454-2643
(541) 454-3279 Fax

PORT OF TACOMA
WAD001882984
3400 TAYLOR WAY
TACOMA WA 98421

CERTIFICATE OF DISPOSAL

Chemical Waste Management of the Northwest, Inc., ORD089452353, has received the following waste material:

GENERATOR:	PORT OF TACOMA
MANIFEST #:	011870091JJK
CWM TRACKING ID:	427948-01
PROFILE #:	OR321468
LINE ITEM:	9b.1
QUANTITY:	1 DT
RECEIVED DATE:	09/10/13
DISPOSAL PROCESS(ES):	LANDFILL
FINAL DISPOSAL LOCATION:	LANDFILL 13
DISPOSAL DATE:	09/10/13

I certify, on behalf of the above listed treatment facility, that to the best of my knowledge, the above-described waste material was managed in compliance with all applicable laws, regulations, permits and licenses on the date listed above.

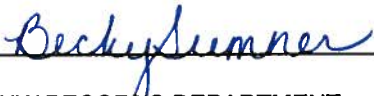

CWMNW RECORDS DEPARTMENT

Date: 09/18/13



CHEMICAL WASTE MANAGEMENT OF THE NW
17629 Cedar Springs Lane
Arlington, OR 97812
(541) 454-2643
(541) 454-3279 Fax

PORT OF TACOMA
WAD001882984
3400 TAYLOR WAY
TACOMA WA 98421

CERTIFICATE OF DISPOSAL

Chemical Waste Management of the Northwest, Inc., ORD089452353, has received the following waste material:

GENERATOR:	PORT OF TACOMA
MANIFEST #:	011870101JJK
CWM TRACKING ID:	427949-01
PROFILE #:	OR321468
LINE ITEM:	9b.1
QUANTITY:	1 DT
RECEIVED DATE:	09/10/13
DISPOSAL PROCESS(ES):	LANDFILL
FINAL DISPOSAL LOCATION:	LANDFILL 13
DISPOSAL DATE:	09/10/13

I certify, on behalf of the above listed treatment facility, that to the best of my knowledge, the above-described waste material was managed in compliance with all applicable laws, regulations, permits and licenses on the date listed above.



CWMNW RECORDS DEPARTMENT
Date: 09/18/13



CHEMICAL WASTE MANAGEMENT OF THE NW
17629 Cedar Springs Lane
Arlington, OR 97812
(541) 454-2643
(541) 454-3279 Fax

PORT OF TACOMA
WAD001882984
3400 TAYLOR WAY
TACOMA WA 98421

CERTIFICATE OF DISPOSAL

Chemical Waste Management of the Northwest, Inc., ORD089452353, has received the following waste material:

GENERATOR:	PORT OF TACOMA
MANIFEST #:	011870095JJK
CWM TRACKING ID:	427951-01
PROFILE #:	OR321468
LINE ITEM:	9b.1
QUANTITY:	1 DT
RECEIVED DATE:	09/10/13
DISPOSAL PROCESS(ES):	LANDFILL
FINAL DISPOSAL LOCATION:	LANDFILL 13
DISPOSAL DATE:	09/10/13

I certify, on behalf of the above listed treatment facility, that to the best of my knowledge, the above-described waste material was managed in compliance with all applicable laws, regulations, permits and licenses on the date listed above.

Becky Sumner

_____ CWMNW RECORDS DEPARTMENT

Date: 09/18/13



CHEMICAL WASTE MANAGEMENT OF THE NW
17629 Cedar Springs Lane
Arlington, OR 97812
(541) 454-2643
(541) 454-3279 Fax

PORT OF TACOMA
WAD001882984
3400 TAYLOR WAY
TACOMA WA 98421

CERTIFICATE OF DISPOSAL

Chemical Waste Management of the Northwest, Inc., ORD089452353, has received the following waste material:

GENERATOR:	PORT OF TACOMA
MANIFEST #:	011870097JJK
CWM TRACKING ID:	427952-01
PROFILE #:	OR321468
LINE ITEM:	9b.1
QUANTITY:	1 DT
RECEIVED DATE:	09/10/13
DISPOSAL PROCESS(ES):	LANDFILL
FINAL DISPOSAL LOCATION:	LANDFILL 13
DISPOSAL DATE:	09/10/13

I certify, on behalf of the above listed treatment facility, that to the best of my knowledge, the above-described waste material was managed in compliance with all applicable laws, regulations, permits and licenses on the date listed above.



CWMNW RECORDS DEPARTMENT

Date: 09/18/13



CHEMICAL WASTE MANAGEMENT OF THE NW
17629 Cedar Springs Lane
Arlington, OR 97812
(541) 454-2643
(541) 454-3279 Fax

PORT OF TACOMA
WAD001882984
3400 TAYLOR WAY
TACOMA WA 98421

CERTIFICATE OF DISPOSAL

Chemical Waste Management of the Northwest, Inc., ORD089452353, has received the following waste material:

GENERATOR:	PORT OF TACOMA
MANIFEST #:	011870087JJK
CWM TRACKING ID:	427953-01
PROFILE #:	OR321468
LINE ITEM:	9b.1
QUANTITY:	1 DT
RECEIVED DATE:	09/10/13
DISPOSAL PROCESS(ES):	LANDFILL
FINAL DISPOSAL LOCATION:	LANDFILL 13
DISPOSAL DATE:	09/10/13

I certify, on behalf of the above listed treatment facility, that to the best of my knowledge, the above-described waste material was managed in compliance with all applicable laws, regulations, permits and licenses on the date listed above.

Becky Sumner

CWMNW RECORDS DEPARTMENT

Date: 09/18/13



CHEMICAL WASTE MANAGEMENT OF THE NW

17629 Cedar Springs Lane
Arlington, OR 97812
(541) 454-2643
(541) 454-3279 Fax

PORT OF TACOMA
WAD001882984
3400 TAYLOR WAY
TACOMA WA 98421

CERTIFICATE OF DISPOSAL

Chemical Waste Management of the Northwest, Inc., ORD089452353, has received the following waste material:

GENERATOR:	PORT OF TACOMA
MANIFEST #:	011870092JJK
CWM TRACKING ID:	427954-01
PROFILE #:	OR321468
LINE ITEM:	9b.1
QUANTITY:	1 DT
RECEIVED DATE:	09/10/13
DISPOSAL PROCESS(ES):	LANDFILL
FINAL DISPOSAL LOCATION:	LANDFILL 13
DISPOSAL DATE:	09/10/13

I certify, on behalf of the above listed treatment facility, that to the best of my knowledge, the above-described waste material was managed in compliance with all applicable laws, regulations, permits and licenses on the date listed above.



CWMNW RECORDS DEPARTMENT

Date: 09/18/13



CHEMICAL WASTE MANAGEMENT OF THE NW

17629 Cedar Springs Lane
Arlington, OR 97812
(541) 454-2643
(541) 454-3279 Fax

PORT OF TACOMA
WAD001882984
3400 TAYLOR WAY
TACOMA WA 98421

CERTIFICATE OF DISPOSAL

Chemical Waste Management of the Northwest, Inc., ORD089452353, has received the following waste material:

GENERATOR:	PORT OF TACOMA
MANIFEST #:	011870084JJK
CWM TRACKING ID:	427956-01
PROFILE #:	OR321468
LINE ITEM:	9b.1
QUANTITY:	1 DT
RECEIVED DATE:	09/10/13
DISPOSAL PROCESS(ES):	LANDFILL
FINAL DISPOSAL LOCATION:	LANDFILL 13
DISPOSAL DATE:	09/10/13

I certify, on behalf of the above listed treatment facility, that to the best of my knowledge, the above-described waste material was managed in compliance with all applicable laws, regulations, permits and licenses on the date listed above.



CWMNW RECORDS DEPARTMENT

Date: 09/18/13



CHEMICAL WASTE MANAGEMENT OF THE NW

17629 Cedar Springs Lane
Arlington, OR 97812
(541) 454-2643
(541) 454-3279 Fax

PORT OF TACOMA
WAD001882984
3400 TAYLOR WAY
TACOMA WA 98421

CERTIFICATE OF DISPOSAL

Chemical Waste Management of the Northwest, Inc., ORD089452353, has received the following waste material:

GENERATOR:	PORT OF TACOMA
MANIFEST #:	011870085JJK
CWM TRACKING ID:	427957-01
PROFILE #:	OR321468
LINE ITEM:	9b.1
QUANTITY:	1 DT
RECEIVED DATE:	09/10/13
DISPOSAL PROCESS(ES):	LANDFILL
FINAL DISPOSAL LOCATION:	LANDFILL 13
DISPOSAL DATE:	09/10/13

I certify, on behalf of the above listed treatment facility, that to the best of my knowledge, the above-described waste material was managed in compliance with all applicable laws, regulations, permits and licenses on the date listed above.



CWMNW RECORDS DEPARTMENT

Date: 09/18/13



CHEMICAL WASTE MANAGEMENT OF THE NW

17629 Cedar Springs Lane
Arlington, OR 97812
(541) 454-2643
(541) 454-3279 Fax

PORT OF TACOMA
WAD001882984
3400 TAYLOR WAY
TACOMA WA 98421

CERTIFICATE OF DISPOSAL

Chemical Waste Management of the Northwest, Inc., ORD089452353, has received the following waste material:

GENERATOR:	PORT OF TACOMA
MANIFEST #:	011870083JJK
CWM TRACKING ID:	427958-01
PROFILE #:	OR321468
LINE ITEM:	9b.1
QUANTITY:	1 DT
RECEIVED DATE:	09/10/13
DISPOSAL PROCESS(ES):	LANDFILL
FINAL DISPOSAL LOCATION:	LANDFILL 13
DISPOSAL DATE:	09/10/13

I certify, on behalf of the above listed treatment facility, that to the best of my knowledge, the above-described waste material was managed in compliance with all applicable laws, regulations, permits and licenses on the date listed above.

Becky Sumner

_____ CWMNW RECORDS DEPARTMENT

Date: 09/18/13



CHEMICAL WASTE MANAGEMENT OF THE NW

17629 Cedar Springs Lane
Arlington, OR 97812
(541) 454-2643
(541) 454-3279 Fax

PORT OF TACOMA
WAD001882984
3400 TAYLOR WAY
TACOMA WA 98421

CERTIFICATE OF DISPOSAL

Chemical Waste Management of the Northwest, Inc., ORD089452353, has received the following waste material:

GENERATOR:	PORT OF TACOMA
MANIFEST #:	011870089JJK
CWM TRACKING ID:	427960-01
PROFILE #:	OR321468
LINE ITEM:	9b.1
QUANTITY:	1 DT
RECEIVED DATE:	09/10/13
DISPOSAL PROCESS(ES):	LANDFILL
FINAL DISPOSAL LOCATION:	LANDFILL 13
DISPOSAL DATE:	09/10/13

I certify, on behalf of the above listed treatment facility, that to the best of my knowledge, the above-described waste material was managed in compliance with all applicable laws, regulations, permits and licenses on the date listed above.

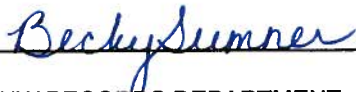

CWMNW RECORDS DEPARTMENT

Date: 09/18/13



CHEMICAL WASTE MANAGEMENT OF THE NW

17629 Cedar Springs Lane
Arlington, OR 97812
(541) 454-2643
(541) 454-3279 Fax

PORT OF TACOMA
WAD001882984
3400 TAYLOR WAY
TACOMA WA 98421

CERTIFICATE OF DISPOSAL

Chemical Waste Management of the Northwest, Inc., ORD089452353, has received the following waste material:

GENERATOR:	PORT OF TACOMA
MANIFEST #:	011870090JJK
CWM TRACKING ID:	427961-01
PROFILE #:	OR321468
LINE ITEM:	9b.1
QUANTITY:	1 DT
RECEIVED DATE:	09/10/13
DISPOSAL PROCESS(ES):	LANDFILL
FINAL DISPOSAL LOCATION:	LANDFILL 13
DISPOSAL DATE:	09/10/13

I certify, on behalf of the above listed treatment facility, that to the best of my knowledge, the above-described waste material was managed in compliance with all applicable laws, regulations, permits and licenses on the date listed above.

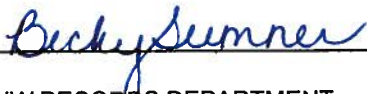

CWMNW RECORDS DEPARTMENT

Date: 09/18/13



CHEMICAL WASTE MANAGEMENT OF THE NW

17629 Cedar Springs Lane
Arlington, OR 97812
(541) 454-2643
(541) 454-3279 Fax

PORT OF TACOMA
WAD001882984
3400 TAYLOR WAY
TACOMA WA 98421

CERTIFICATE OF DISPOSAL

Chemical Waste Management of the Northwest, Inc., ORD089452353, has received the following waste material:

GENERATOR:	PORT OF TACOMA
MANIFEST #:	011870076JJK
CWM TRACKING ID:	427962-01
PROFILE #:	OR321468
LINE ITEM:	9b.1
QUANTITY:	1 DT
RECEIVED DATE:	09/10/13
DISPOSAL PROCESS(ES):	LANDFILL
FINAL DISPOSAL LOCATION:	LANDFILL 13
DISPOSAL DATE:	09/10/13

I certify, on behalf of the above listed treatment facility, that to the best of my knowledge, the above-described waste material was managed in compliance with all applicable laws, regulations, permits and licenses on the date listed above.



CWMNW RECORDS DEPARTMENT
Date: 09/18/13



CHEMICAL WASTE MANAGEMENT OF THE NW

17629 Cedar Springs Lane
Arlington, OR 97812
(541) 454-2643
(541) 454-3279 Fax

PORT OF TACOMA
WAD001882984
3400 TAYLOR WAY
TACOMA WA 98421

CERTIFICATE OF DISPOSAL

Chemical Waste Management of the Northwest, Inc., ORD089452353, has received the following waste material:

GENERATOR:	PORT OF TACOMA
MANIFEST #:	011870072JJK
CWM TRACKING ID:	427963-01
PROFILE #:	OR321468
LINE ITEM:	9b.1
QUANTITY:	1 DT
RECEIVED DATE:	09/10/13
DISPOSAL PROCESS(ES):	LANDFILL
FINAL DISPOSAL LOCATION:	LANDFILL 13
DISPOSAL DATE:	09/10/13

I certify, on behalf of the above listed treatment facility, that to the best of my knowledge, the above-described waste material was managed in compliance with all applicable laws, regulations, permits and licenses on the date listed above.

Becky Sumner

CWMNW RECORDS DEPARTMENT

Date: 09/18/13



CHEMICAL WASTE MANAGEMENT OF THE NW

17629 Cedar Springs Lane
Arlington, OR 97812
(541) 454-2643
(541) 454-3279 Fax

PORT OF TACOMA
WAD001882984
3400 TAYLOR WAY
TACOMA WA 98421

CERTIFICATE OF DISPOSAL

Chemical Waste Management of the Northwest, Inc., ORD089452353, has received the following waste material:

GENERATOR:	PORT OF TACOMA
MANIFEST #:	011870086JJK
CWM TRACKING ID:	427965-01
PROFILE #:	OR321468
LINE ITEM:	9b.1
QUANTITY:	1 DT
RECEIVED DATE:	09/10/13
DISPOSAL PROCESS(ES):	LANDFILL
FINAL DISPOSAL LOCATION:	LANDFILL 13
DISPOSAL DATE:	09/10/13

I certify, on behalf of the above listed treatment facility, that to the best of my knowledge, the above-described waste material was managed in compliance with all applicable laws, regulations, permits and licenses on the date listed above.

Becky Sumner

CWMNW RECORDS DEPARTMENT

Date: 09/18/13



CHEMICAL WASTE MANAGEMENT OF THE NW

17629 Cedar Springs Lane
Arlington, OR 97812
(541) 454-2643
(541) 454-3279 Fax

PORT OF TACOMA
WAD001882984
3400 TAYLOR WAY
TACOMA WA 98421

CERTIFICATE OF DISPOSAL

Chemical Waste Management of the Northwest, Inc., ORD089452353, has received the following waste material:

GENERATOR:	PORT OF TACOMA
MANIFEST #:	011870073JJK
CWM TRACKING ID:	427966-01
PROFILE #:	OR321468
LINE ITEM:	9b.1
QUANTITY:	1 DT
RECEIVED DATE:	09/10/13
DISPOSAL PROCESS(ES):	LANDFILL
FINAL DISPOSAL LOCATION:	LANDFILL 13
DISPOSAL DATE:	09/10/13

I certify, on behalf of the above listed treatment facility, that to the best of my knowledge, the above-described waste material was managed in compliance with all applicable laws, regulations, permits and licenses on the date listed above.

Becky Sumner

CWMNW RECORDS DEPARTMENT

Date: 09/18/13



CHEMICAL WASTE MANAGEMENT OF THE NW

17629 Cedar Springs Lane
Arlington, OR 97812
(541) 454-2643
(541) 454-3279 Fax

PORT OF TACOMA
WAD001882984
3400 TAYLOR WAY
TACOMA WA 98421

CERTIFICATE OF DISPOSAL

Chemical Waste Management of the Northwest, Inc., ORD089452353, has received the following waste material:

GENERATOR:	PORT OF TACOMA
MANIFEST #:	011870088JJK
CWM TRACKING ID:	427967-01
PROFILE #:	OR321468
LINE ITEM:	9b.1
QUANTITY:	1 DT
RECEIVED DATE:	09/10/13
DISPOSAL PROCESS(ES):	LANDFILL
FINAL DISPOSAL LOCATION:	LANDFILL 13
DISPOSAL DATE:	09/10/13

I certify, on behalf of the above listed treatment facility, that to the best of my knowledge, the above-described waste material was managed in compliance with all applicable laws, regulations, permits and licenses on the date listed above.



CWMNW RECORDS DEPARTMENT

Date: 09/18/13



CHEMICAL WASTE MANAGEMENT OF THE NW

17629 Cedar Springs Lane
Arlington, OR 97812
(541) 454-2643
(541) 454-3279 Fax

PORT OF TACOMA
WAD001882984
3400 TAYLOR WAY
TACOMA WA 98421

CERTIFICATE OF DISPOSAL

Chemical Waste Management of the Northwest, Inc., ORD089452353, has received the following waste material:

GENERATOR:	PORT OF TACOMA
MANIFEST #:	011870075JJK
CWM TRACKING ID:	427968-01
PROFILE #:	OR321468
LINE ITEM:	9b.1
QUANTITY:	1 DT
RECEIVED DATE:	09/10/13
DISPOSAL PROCESS(ES):	LANDFILL
FINAL DISPOSAL LOCATION:	LANDFILL 13
DISPOSAL DATE:	09/10/13

I certify, on behalf of the above listed treatment facility, that to the best of my knowledge, the above-described waste material was managed in compliance with all applicable laws, regulations, permits and licenses on the date listed above.



CWMNW RECORDS DEPARTMENT

Date: 09/18/13



CHEMICAL WASTE MANAGEMENT OF THE NW

17629 Cedar Springs Lane
Arlington, OR 97812
(541) 454-2643
(541) 454-3279 Fax

PORT OF TACOMA
WAD001882984
3400 TAYLOR WAY
TACOMA WA 98421

CERTIFICATE OF DISPOSAL

Chemical Waste Management of the Northwest, Inc., ORD089452353, has received the following waste material:

GENERATOR:	PORT OF TACOMA
MANIFEST #:	011870074JJK
CWM TRACKING ID:	427969-01
PROFILE #:	OR321468
LINE ITEM:	9b.1
QUANTITY:	1 DT
RECEIVED DATE:	09/10/13
DISPOSAL PROCESS(ES):	LANDFILL
FINAL DISPOSAL LOCATION:	LANDFILL 13
DISPOSAL DATE:	09/10/13

I certify, on behalf of the above listed treatment facility, that to the best of my knowledge, the above-described waste material was managed in compliance with all applicable laws, regulations, permits and licenses on the date listed above.



CWMNW RECORDS DEPARTMENT

Date: 09/18/13



CHEMICAL WASTE MANAGEMENT OF THE NW

17629 Cedar Springs Lane
Arlington, OR 97812
(541) 454-2643
(541) 454-3279 Fax

PORT OF TACOMA
WAD001882984
3400 TAYLOR WAY
TACOMA WA 98421

CERTIFICATE OF DISPOSAL

Chemical Waste Management of the Northwest, Inc., ORD089452353, has received the following waste material:

GENERATOR:	PORT OF TACOMA
MANIFEST #:	011870077JJK
CWM TRACKING ID:	427971-01
PROFILE #:	OR321468
LINE ITEM:	9b.1
QUANTITY:	1 DT
RECEIVED DATE:	09/10/13
DISPOSAL PROCESS(ES):	LANDFILL
FINAL DISPOSAL LOCATION:	LANDFILL 13
DISPOSAL DATE:	09/10/13

I certify, on behalf of the above listed treatment facility, that to the best of my knowledge, the above-described waste material was managed in compliance with all applicable laws, regulations, permits and licenses on the date listed above.



CWMNW RECORDS DEPARTMENT

Date: 09/18/13



CHEMICAL WASTE MANAGEMENT OF THE NW

17629 Cedar Springs Lane
Arlington, OR 97812
(541) 454-2643
(541) 454-3279 Fax

PORT OF TACOMA
WAD001882984
3400 TAYLOR WAY
TACOMA WA 98421

CERTIFICATE OF DISPOSAL

Chemical Waste Management of the Northwest, Inc., ORD089452353, has received the following waste material:

GENERATOR:	PORT OF TACOMA
MANIFEST #:	011870078JJK
CWM TRACKING ID:	427973-01
PROFILE #:	OR321468
LINE ITEM:	9b.1
QUANTITY:	1 DT
RECEIVED DATE:	09/10/13
DISPOSAL PROCESS(ES):	LANDFILL
FINAL DISPOSAL LOCATION:	LANDFILL 13
DISPOSAL DATE:	09/10/13

I certify, on behalf of the above listed treatment facility, that to the best of my knowledge, the above-described waste material was managed in compliance with all applicable laws, regulations, permits and licenses on the date listed above.



CWMNW RECORDS DEPARTMENT

Date: 09/18/13



CHEMICAL WASTE MANAGEMENT OF THE NW

17629 Cedar Springs Lane
Arlington, OR 97812
(541) 454-2643
(541) 454-3279 Fax

PORT OF TACOMA
WAD001882984
3400 TAYLOR WAY
TACOMA WA 98421

CERTIFICATE OF DISPOSAL

Chemical Waste Management of the Northwest, Inc., ORD089452353, has received the following waste material:

GENERATOR:	PORT OF TACOMA
MANIFEST #:	011870080JJK
CWM TRACKING ID:	427974-01
PROFILE #:	OR321468
LINE ITEM:	9b.1
QUANTITY:	1 DT
RECEIVED DATE:	09/10/13
DISPOSAL PROCESS(ES):	LANDFILL
FINAL DISPOSAL LOCATION:	LANDFILL 13
DISPOSAL DATE:	09/10/13

I certify, on behalf of the above listed treatment facility, that to the best of my knowledge, the above-described waste material was managed in compliance with all applicable laws, regulations, permits and licenses on the date listed above.

Becky Sumner

CWMNW RECORDS DEPARTMENT

Date: 09/18/13



CHEMICAL WASTE MANAGEMENT OF THE NW

17629 Cedar Springs Lane
Arlington, OR 97812
(541) 454-2643
(541) 454-3279 Fax

PORT OF TACOMA
WAD001882984
3400 TAYLOR WAY
TACOMA WA 98421

CERTIFICATE OF DISPOSAL

Chemical Waste Management of the Northwest, Inc., ORD089452353, has received the following waste material:

GENERATOR:	PORT OF TACOMA
MANIFEST #:	011870081JJK
CWM TRACKING ID:	427975-01
PROFILE #:	OR321468
LINE ITEM:	9b.1
QUANTITY:	1 DT
RECEIVED DATE:	09/10/13
DISPOSAL PROCESS(ES):	LANDFILL
FINAL DISPOSAL LOCATION:	LANDFILL 13
DISPOSAL DATE:	09/10/13

I certify, on behalf of the above listed treatment facility, that to the best of my knowledge, the above-described waste material was managed in compliance with all applicable laws, regulations, permits and licenses on the date listed above.

Becky Sumner

CWMNW RECORDS DEPARTMENT

Date: 09/18/13



CHEMICAL WASTE MANAGEMENT OF THE NW

17629 Cedar Springs Lane
Arlington, OR 97812
(541) 454-2643
(541) 454-3279 Fax

PORT OF TACOMA
WAD001882984
3400 TAYLOR WAY
TACOMA WA 98421

CERTIFICATE OF DISPOSAL

Chemical Waste Management of the Northwest, Inc., ORD089452353, has received the following waste material:

GENERATOR:	PORT OF TACOMA
MANIFEST #:	011870082JJK
CWM TRACKING ID:	427976-01
PROFILE #:	OR321468
LINE ITEM:	9b.1
QUANTITY:	1 DT
RECEIVED DATE:	09/10/13
DISPOSAL PROCESS(ES):	LANDFILL
FINAL DISPOSAL LOCATION:	LANDFILL 13
DISPOSAL DATE:	09/10/13

I certify, on behalf of the above listed treatment facility, that to the best of my knowledge, the above-described waste material was managed in compliance with all applicable laws, regulations, permits and licenses on the date listed above.



CWMNW RECORDS DEPARTMENT
Date: 09/18/13



CHEMICAL WASTE MANAGEMENT OF THE NW

17629 Cedar Springs Lane
Arlington, OR 97812
(541) 454-2643
(541) 454-3279 Fax

PORT OF TACOMA
WAD001882984
3400 TAYLOR WAY
TACOMA WA 98421

CERTIFICATE OF DISPOSAL

Chemical Waste Management of the Northwest, Inc., ORD089452353, has received the following waste material:

GENERATOR:	PORT OF TACOMA
MANIFEST #:	011870079JJK
CWM TRACKING ID:	428002-01
PROFILE #:	OR321468
LINE ITEM:	9b.1
QUANTITY:	1 DT
RECEIVED DATE:	09/11/13
DISPOSAL PROCESS(ES):	LANDFILL
FINAL DISPOSAL LOCATION:	LANDFILL 13
DISPOSAL DATE:	09/11/13

I certify, on behalf of the above listed treatment facility, that to the best of my knowledge, the above-described waste material was managed in compliance with all applicable laws, regulations, permits and licenses on the date listed above.

Becky Sumner

CWMNW RECORDS DEPARTMENT

Date: 09/18/13



CHEMICAL WASTE MANAGEMENT OF THE NW

17629 Cedar Springs Lane
Arlington, OR 97812
(541) 454-2643
(541) 454-3279 Fax

PORT OF TACOMA
WAD001882984
3400 TAYLOR WAY
TACOMA WA 98421

CERTIFICATE OF DISPOSAL

Chemical Waste Management of the Northwest, Inc., ORD089452353, has received the following waste material:

GENERATOR:	PORT OF TACOMA
MANIFEST #:	011870129JJK
CWM TRACKING ID:	428013-01
PROFILE #:	OR321468
LINE ITEM:	9b.1
QUANTITY:	1 DT
RECEIVED DATE:	09/11/13
DISPOSAL PROCESS(ES):	LANDFILL
FINAL DISPOSAL LOCATION:	LANDFILL 13
DISPOSAL DATE:	09/11/13

I certify, on behalf of the above listed treatment facility, that to the best of my knowledge, the above-described waste material was managed in compliance with all applicable laws, regulations, permits and licenses on the date listed above.

Becky Sumner

CWMNW RECORDS DEPARTMENT

Date: 09/18/13



CHEMICAL WASTE MANAGEMENT OF THE NW

17629 Cedar Springs Lane
Arlington, OR 97812
(541) 454-2643
(541) 454-3279 Fax

PORT OF TACOMA
WAD001882984
3400 TAYLOR WAY
TACOMA WA 98421

CERTIFICATE OF DISPOSAL

Chemical Waste Management of the Northwest, Inc., ORD089452353, has received the following waste material:

GENERATOR:	PORT OF TACOMA
MANIFEST #:	011870132JJK
CWM TRACKING ID:	428016-01
PROFILE #:	OR321468
LINE ITEM:	9b.1
QUANTITY:	1 DT
RECEIVED DATE:	09/11/13
DISPOSAL PROCESS(ES):	LANDFILL
FINAL DISPOSAL LOCATION:	LANDFILL 13
DISPOSAL DATE:	09/11/13

I certify, on behalf of the above listed treatment facility, that to the best of my knowledge, the above-described waste material was managed in compliance with all applicable laws, regulations, permits and licenses on the date listed above.



CWMNW RECORDS DEPARTMENT

Date: 09/18/13



CHEMICAL WASTE MANAGEMENT OF THE NW

17629 Cedar Springs Lane
Arlington, OR 97812
(541) 454-2643
(541) 454-3279 Fax

PORT OF TACOMA
WAD001882984
3400 TAYLOR WAY
TACOMA WA 98421

CERTIFICATE OF DISPOSAL

Chemical Waste Management of the Northwest, Inc., ORD089452353, has received the following waste material:

GENERATOR:	PORT OF TACOMA
MANIFEST #:	011870133JJK
CWM TRACKING ID:	428017-01
PROFILE #:	OR321468
LINE ITEM:	9b.1
QUANTITY:	1 DT
RECEIVED DATE:	09/11/13
DISPOSAL PROCESS(ES):	LANDFILL
FINAL DISPOSAL LOCATION:	LANDFILL 13
DISPOSAL DATE:	09/11/13

I certify, on behalf of the above listed treatment facility, that to the best of my knowledge, the above-described waste material was managed in compliance with all applicable laws, regulations, permits and licenses on the date listed above.



CWMNW RECORDS DEPARTMENT

Date: 09/18/13



CHEMICAL WASTE MANAGEMENT OF THE NW

17629 Cedar Springs Lane
Arlington, OR 97812
(541) 454-2643
(541) 454-3279 Fax

PORT OF TACOMA
WAD001882984
3400 TAYLOR WAY
TACOMA WA 98421

CERTIFICATE OF DISPOSAL

Chemical Waste Management of the Northwest, Inc., ORD089452353, has received the following waste material:

GENERATOR:	PORT OF TACOMA
MANIFEST #:	011870128JJK
CWM TRACKING ID:	428018-01
PROFILE #:	OR321468
LINE ITEM:	9b.1
QUANTITY:	1 DT
RECEIVED DATE:	09/11/13
DISPOSAL PROCESS(ES):	LANDFILL
FINAL DISPOSAL LOCATION:	LANDFILL 13
DISPOSAL DATE:	09/11/13

I certify, on behalf of the above listed treatment facility, that to the best of my knowledge, the above-described waste material was managed in compliance with all applicable laws, regulations, permits and licenses on the date listed above.



CWMNW RECORDS DEPARTMENT

Date: 09/18/13



CHEMICAL WASTE MANAGEMENT OF THE NW

17629 Cedar Springs Lane
Arlington, OR 97812
(541) 454-2643
(541) 454-3279 Fax

PORT OF TACOMA
WAD001882984
3400 TAYLOR WAY
TACOMA WA 98421

CERTIFICATE OF DISPOSAL

Chemical Waste Management of the Northwest, Inc., ORD089452353, has received the following waste material:

GENERATOR:	PORT OF TACOMA
MANIFEST #:	011870123JJK
CWM TRACKING ID:	428021-01
PROFILE #:	OR321468
LINE ITEM:	9b.1
QUANTITY:	1 DT
RECEIVED DATE:	09/11/13
DISPOSAL PROCESS(ES):	LANDFILL
FINAL DISPOSAL LOCATION:	LANDFILL 13
DISPOSAL DATE:	09/11/13

I certify, on behalf of the above listed treatment facility, that to the best of my knowledge, the above-described waste material was managed in compliance with all applicable laws, regulations, permits and licenses on the date listed above.



CWMNW RECORDS DEPARTMENT

Date: 09/18/13



CHEMICAL WASTE MANAGEMENT OF THE NW

17629 Cedar Springs Lane
Arlington, OR 97812
(541) 454-2643
(541) 454-3279 Fax

PORT OF TACOMA
WAD001882984
3400 TAYLOR WAY
TACOMA WA 98421

CERTIFICATE OF DISPOSAL

Chemical Waste Management of the Northwest, Inc., ORD089452353, has received the following waste material:

GENERATOR:	PORT OF TACOMA
MANIFEST #:	011870130JJK
CWM TRACKING ID:	428022-01
PROFILE #:	OR321468
LINE ITEM:	9b.1
QUANTITY:	1 DT
RECEIVED DATE:	09/11/13
DISPOSAL PROCESS(ES):	LANDFILL
FINAL DISPOSAL LOCATION:	LANDFILL 13
DISPOSAL DATE:	09/11/13

I certify, on behalf of the above listed treatment facility, that to the best of my knowledge, the above-described waste material was managed in compliance with all applicable laws, regulations, permits and licenses on the date listed above.



CWMNW RECORDS DEPARTMENT

Date: 09/18/13



CHEMICAL WASTE MANAGEMENT OF THE NW
17629 Cedar Springs Lane
Arlington, OR 97812
(541) 454-2643
(541) 454-3279 Fax

PORT OF TACOMA
WAD001882984
3400 TAYLOR WAY
TACOMA WA 98421

CERTIFICATE OF DISPOSAL

Chemical Waste Management of the Northwest, Inc., ORD089452353, has received the following waste material:

GENERATOR:	PORT OF TACOMA
MANIFEST #:	011870131JJK
CWM TRACKING ID:	428023-01
PROFILE #:	OR321468
LINE ITEM:	9b.1
QUANTITY:	1 DT
RECEIVED DATE:	09/11/13
DISPOSAL PROCESS(ES):	LANDFILL
FINAL DISPOSAL LOCATION:	LANDFILL 13
DISPOSAL DATE:	09/11/13

I certify, on behalf of the above listed treatment facility, that to the best of my knowledge, the above-described waste material was managed in compliance with all applicable laws, regulations, permits and licenses on the date listed above.



CWMNW RECORDS DEPARTMENT

Date: 09/18/13



CHEMICAL WASTE MANAGEMENT OF THE NW

17629 Cedar Springs Lane
Arlington, OR 97812
(541) 454-2643
(541) 454-3279 Fax

PORT OF TACOMA
WAD001882984
3400 TAYLOR WAY
TACOMA WA 98421

CERTIFICATE OF DISPOSAL

Chemical Waste Management of the Northwest, Inc., ORD089452353, has received the following waste material:

GENERATOR:	PORT OF TACOMA
MANIFEST #:	011870124JJK
CWM TRACKING ID:	428025-01
PROFILE #:	OR321468
LINE ITEM:	9b.1
QUANTITY:	1 DT
RECEIVED DATE:	09/11/13
DISPOSAL PROCESS(ES):	LANDFILL
FINAL DISPOSAL LOCATION:	LANDFILL 13
DISPOSAL DATE:	09/11/13

I certify, on behalf of the above listed treatment facility, that to the best of my knowledge, the above-described waste material was managed in compliance with all applicable laws, regulations, permits and licenses on the date listed above.



CWMNW RECORDS DEPARTMENT

Date: 09/18/13



CHEMICAL WASTE MANAGEMENT OF THE NW

17629 Cedar Springs Lane
Arlington, OR 97812
(541) 454-2643
(541) 454-3279 Fax

PORT OF TACOMA
WAD001882984
3400 TAYLOR WAY
TACOMA WA 98421

CERTIFICATE OF DISPOSAL

Chemical Waste Management of the Northwest, Inc., ORD089452353, has received the following waste material:

GENERATOR:	PORT OF TACOMA
MANIFEST #:	011870134JJK
CWM TRACKING ID:	428026-01
PROFILE #:	OR321468
LINE ITEM:	9b.1
QUANTITY:	1 DT
RECEIVED DATE:	09/11/13
DISPOSAL PROCESS(ES):	LANDFILL
FINAL DISPOSAL LOCATION:	LANDFILL 13
DISPOSAL DATE:	09/11/13

I certify, on behalf of the above listed treatment facility, that to the best of my knowledge, the above-described waste material was managed in compliance with all applicable laws, regulations, permits and licenses on the date listed above.



CWMNW RECORDS DEPARTMENT

Date: 09/18/13



CHEMICAL WASTE MANAGEMENT OF THE NW

17629 Cedar Springs Lane
Arlington, OR 97812
(541) 454-2643
(541) 454-3279 Fax

PORT OF TACOMA
WAD001882984
3400 TAYLOR WAY
TACOMA WA 98421

CERTIFICATE OF DISPOSAL

Chemical Waste Management of the Northwest, Inc., ORD089452353, has received the following waste material:

GENERATOR:	PORT OF TACOMA
MANIFEST #:	011870122JJK
CWM TRACKING ID:	428027-01
PROFILE #:	OR321468
LINE ITEM:	9b.1
QUANTITY:	1 DT
RECEIVED DATE:	09/11/13
DISPOSAL PROCESS(ES):	LANDFILL
FINAL DISPOSAL LOCATION:	LANDFILL 13
DISPOSAL DATE:	09/11/13

I certify, on behalf of the above listed treatment facility, that to the best of my knowledge, the above-described waste material was managed in compliance with all applicable laws, regulations, permits and licenses on the date listed above.

Becky Sumner

CWMNW RECORDS DEPARTMENT

Date: 09/18/13



CHEMICAL WASTE MANAGEMENT OF THE NW

17629 Cedar Springs Lane
Arlington, OR 97812
(541) 454-2643
(541) 454-3279 Fax

PORT OF TACOMA
WAD001882984
3400 TAYLOR WAY
TACOMA WA 98421

CERTIFICATE OF DISPOSAL

Chemical Waste Management of the Northwest, Inc., ORD089452353, has received the following waste material:

GENERATOR:	PORT OF TACOMA
MANIFEST #:	011870125JJK
CWM TRACKING ID:	428028-01
PROFILE #:	OR321468
LINE ITEM:	9b.1
QUANTITY:	1 DT
RECEIVED DATE:	09/11/13
DISPOSAL PROCESS(ES):	LANDFILL
FINAL DISPOSAL LOCATION:	LANDFILL 13
DISPOSAL DATE:	09/11/13

I certify, on behalf of the above listed treatment facility, that to the best of my knowledge, the above-described waste material was managed in compliance with all applicable laws, regulations, permits and licenses on the date listed above.



CWMNW RECORDS DEPARTMENT

Date: 09/18/13



CHEMICAL WASTE MANAGEMENT OF THE NW
17629 Cedar Springs Lane
Arlington, OR 97812
(541) 454-2643
(541) 454-3279 Fax

PORT OF TACOMA
WAD001882984
3400 TAYLOR WAY
TACOMA WA 98421

CERTIFICATE OF DISPOSAL

Chemical Waste Management of the Northwest, Inc., ORD089452353, has received the following waste material:

GENERATOR:	PORT OF TACOMA
MANIFEST #:	011870120JJK
CWM TRACKING ID:	428029-01
PROFILE #:	OR321468
LINE ITEM:	9b.1
QUANTITY:	1 DT
RECEIVED DATE:	09/11/13
DISPOSAL PROCESS(ES):	LANDFILL
FINAL DISPOSAL LOCATION:	LANDFILL 13
DISPOSAL DATE:	09/11/13

I certify, on behalf of the above listed treatment facility, that to the best of my knowledge, the above-described waste material was managed in compliance with all applicable laws, regulations, permits and licenses on the date listed above.



CWMNW RECORDS DEPARTMENT
Date: 09/18/13



CHEMICAL WASTE MANAGEMENT OF THE NW
17629 Cedar Springs Lane
Arlington, OR 97812
(541) 454-2643
(541) 454-3279 Fax

PORT OF TACOMA
WAD001882984
3400 TAYLOR WAY
TACOMA WA 98421

CERTIFICATE OF DISPOSAL

Chemical Waste Management of the Northwest, Inc., ORD089452353, has received the following waste material:

GENERATOR:	PORT OF TACOMA
MANIFEST #:	011870135JJK
CWM TRACKING ID:	428030-01
PROFILE #:	OR321468
LINE ITEM:	9b.1
QUANTITY:	1 DT
RECEIVED DATE:	09/11/13
DISPOSAL PROCESS(ES):	LANDFILL
FINAL DISPOSAL LOCATION:	LANDFILL 13
DISPOSAL DATE:	09/11/13

I certify, on behalf of the above listed treatment facility, that to the best of my knowledge, the above-described waste material was managed in compliance with all applicable laws, regulations, permits and licenses on the date listed above.



CWMNW RECORDS DEPARTMENT
Date: 09/18/13



CHEMICAL WASTE MANAGEMENT OF THE NW

17629 Cedar Springs Lane
Arlington, OR 97812
(541) 454-2643
(541) 454-3279 Fax

PORT OF TACOMA
WAD001882984
3400 TAYLOR WAY
TACOMA WA 98421

CERTIFICATE OF DISPOSAL

Chemical Waste Management of the Northwest, Inc., ORD089452353, has received the following waste material:

GENERATOR:	PORT OF TACOMA
MANIFEST #:	011870121JJK
CWM TRACKING ID:	428032-01
PROFILE #:	OR321468
LINE ITEM:	9b.1
QUANTITY:	1 DT
RECEIVED DATE:	09/11/13
DISPOSAL PROCESS(ES):	LANDFILL
FINAL DISPOSAL LOCATION:	LANDFILL 13
DISPOSAL DATE:	09/11/13

I certify, on behalf of the above listed treatment facility, that to the best of my knowledge, the above-described waste material was managed in compliance with all applicable laws, regulations, permits and licenses on the date listed above.



CWMNW RECORDS DEPARTMENT
Date: 09/18/13



CHEMICAL WASTE MANAGEMENT OF THE NW

17629 Cedar Springs Lane
Arlington, OR 97812
(541) 454-2643
(541) 454-3279 Fax

PORT OF TACOMA
WAD001882984
3400 TAYLOR WAY
TACOMA WA 98421

CERTIFICATE OF DISPOSAL

Chemical Waste Management of the Northwest, Inc., ORD089452353, has received the following waste material:

GENERATOR:	PORT OF TACOMA
MANIFEST #:	011870137JJK
CWM TRACKING ID:	428033-01
PROFILE #:	OR321468
LINE ITEM:	9b.1
QUANTITY:	1 DT
RECEIVED DATE:	09/11/13
DISPOSAL PROCESS(ES):	LANDFILL
FINAL DISPOSAL LOCATION:	LANDFILL 13
DISPOSAL DATE:	09/11/13

I certify, on behalf of the above listed treatment facility, that to the best of my knowledge, the above-described waste material was managed in compliance with all applicable laws, regulations, permits and licenses on the date listed above.



CWMNW RECORDS DEPARTMENT

Date: 09/18/13



CHEMICAL WASTE MANAGEMENT OF THE NW

17629 Cedar Springs Lane
Arlington, OR 97812
(541) 454-2643
(541) 454-3279 Fax

PORT OF TACOMA
WAD001882984
3400 TAYLOR WAY
TACOMA WA 98421

CERTIFICATE OF DISPOSAL

Chemical Waste Management of the Northwest, Inc., ORD089452353, has received the following waste material:

GENERATOR:	PORT OF TACOMA
MANIFEST #:	011870127JJK
CWM TRACKING ID:	428034-01
PROFILE #:	OR321468
LINE ITEM:	9b.1
QUANTITY:	1 DT
RECEIVED DATE:	09/11/13
DISPOSAL PROCESS(ES):	LANDFILL
FINAL DISPOSAL LOCATION:	LANDFILL 13
DISPOSAL DATE:	09/11/13

I certify, on behalf of the above listed treatment facility, that to the best of my knowledge, the above-described waste material was managed in compliance with all applicable laws, regulations, permits and licenses on the date listed above.

Becky Sumner

CWMNW RECORDS DEPARTMENT

Date: 09/18/13



CHEMICAL WASTE MANAGEMENT OF THE NW

17629 Cedar Springs Lane
Arlington, OR 97812
(541) 454-2643
(541) 454-3279 Fax

PORT OF TACOMA
WAD001882984
3400 TAYLOR WAY
TACOMA WA 98421

CERTIFICATE OF DISPOSAL

Chemical Waste Management of the Northwest, Inc., ORD089452353, has received the following waste material:

GENERATOR:	PORT OF TACOMA
MANIFEST #:	011870126JJK
CWM TRACKING ID:	428035-01
PROFILE #:	OR321468
LINE ITEM:	9b.1
QUANTITY:	1 DT
RECEIVED DATE:	09/11/13
DISPOSAL PROCESS(ES):	LANDFILL
FINAL DISPOSAL LOCATION:	LANDFILL 13
DISPOSAL DATE:	09/11/13

I certify, on behalf of the above listed treatment facility, that to the best of my knowledge, the above-described waste material was managed in compliance with all applicable laws, regulations, permits and licenses on the date listed above.

Becky Sumner

CWMNW RECORDS DEPARTMENT

Date: 09/18/13



CHEMICAL WASTE MANAGEMENT OF THE NW
17629 Cedar Springs Lane
Arlington, OR 97812
(541) 454-2643
(541) 454-3279 Fax

PORT OF TACOMA
WAD001882984
3400 TAYLOR WAY
TACOMA WA 98421

CERTIFICATE OF DISPOSAL

Chemical Waste Management of the Northwest, Inc., ORD089452353, has received the following waste material:

GENERATOR:	PORT OF TACOMA
MANIFEST #:	011870136JJK
CWM TRACKING ID:	428036-01
PROFILE #:	OR321468
LINE ITEM:	9b.1
QUANTITY:	1 DT
RECEIVED DATE:	09/11/13
DISPOSAL PROCESS(ES):	LANDFILL
FINAL DISPOSAL LOCATION:	LANDFILL 13
DISPOSAL DATE:	09/11/13

I certify, on behalf of the above listed treatment facility, that to the best of my knowledge, the above-described waste material was managed in compliance with all applicable laws, regulations, permits and licenses on the date listed above.



CWMNW RECORDS DEPARTMENT

Date: 09/18/13



CHEMICAL WASTE MANAGEMENT OF THE NW

17629 Cedar Springs Lane
Arlington, OR 97812
(541) 454-2643
(541) 454-3279 Fax

PORT OF TACOMA
WAD001882984
3400 TAYLOR WAY
TACOMA WA 98421

CERTIFICATE OF DISPOSAL

Chemical Waste Management of the Northwest, Inc., ORD089452353, has received the following waste material:

GENERATOR:	PORT OF TACOMA
MANIFEST #:	011870115JJK
CWM TRACKING ID:	428037-01
PROFILE #:	OR321468
LINE ITEM:	9b.1
QUANTITY:	1 DT
RECEIVED DATE:	09/11/13
DISPOSAL PROCESS(ES):	LANDFILL
FINAL DISPOSAL LOCATION:	LANDFILL 13
DISPOSAL DATE:	09/11/13

I certify, on behalf of the above listed treatment facility, that to the best of my knowledge, the above-described waste material was managed in compliance with all applicable laws, regulations, permits and licenses on the date listed above.

Becky Sumner

CWMNW RECORDS DEPARTMENT

Date:

09/18/13



CHEMICAL WASTE MANAGEMENT OF THE NW

17629 Cedar Springs Lane
Arlington, OR 97812
(541) 454-2643
(541) 454-3279 Fax

PORT OF TACOMA
WAD001882984
3400 TAYLOR WAY
TACOMA WA 98421

CERTIFICATE OF DISPOSAL

Chemical Waste Management of the Northwest, Inc., ORD089452353, has received the following waste material:

GENERATOR:	PORT OF TACOMA
MANIFEST #:	011870119JJK
CWM TRACKING ID:	428038-01
PROFILE #:	OR321468
LINE ITEM:	9b.1
QUANTITY:	1 DT
RECEIVED DATE:	09/11/13
DISPOSAL PROCESS(ES):	LANDFILL
FINAL DISPOSAL LOCATION:	LANDFILL 13
DISPOSAL DATE:	09/11/13

I certify, on behalf of the above listed treatment facility, that to the best of my knowledge, the above-described waste material was managed in compliance with all applicable laws, regulations, permits and licenses on the date listed above.



CWMNW RECORDS DEPARTMENT

Date: 09/18/13



CHEMICAL WASTE MANAGEMENT OF THE NW

17629 Cedar Springs Lane
Arlington, OR 97812
(541) 454-2643
(541) 454-3279 Fax

PORT OF TACOMA
WAD001882984
3400 TAYLOR WAY
TACOMA WA 98421

CERTIFICATE OF DISPOSAL

Chemical Waste Management of the Northwest, Inc., ORD089452353, has received the following waste material:

GENERATOR:	PORT OF TACOMA
MANIFEST #:	011870117JJK
CWM TRACKING ID:	428039-01
PROFILE #:	OR321468
LINE ITEM:	9b.1
QUANTITY:	1 DT
RECEIVED DATE:	09/11/13
DISPOSAL PROCESS(ES):	LANDFILL
FINAL DISPOSAL LOCATION:	LANDFILL 13
DISPOSAL DATE:	09/11/13

I certify, on behalf of the above listed treatment facility, that to the best of my knowledge, the above-described waste material was managed in compliance with all applicable laws, regulations, permits and licenses on the date listed above.

Becky Seemner

CWMNW RECORDS DEPARTMENT

Date: 09/18/13



CHEMICAL WASTE MANAGEMENT OF THE NW

17629 Cedar Springs Lane
Arlington, OR 97812
(541) 454-2643
(541) 454-3279 Fax

PORT OF TACOMA
WAD001882984
3400 TAYLOR WAY
TACOMA WA 98421

CERTIFICATE OF DISPOSAL

Chemical Waste Management of the Northwest, Inc., ORD089452353, has received the following waste material:

GENERATOR:	PORT OF TACOMA
MANIFEST #:	011870116JJK
CWM TRACKING ID:	428040-01
PROFILE #:	OR321468
LINE ITEM:	9b.1
QUANTITY:	1 DT
RECEIVED DATE:	09/11/13
DISPOSAL PROCESS(ES):	LANDFILL
FINAL DISPOSAL LOCATION:	LANDFILL 13
DISPOSAL DATE:	09/11/13

I certify, on behalf of the above listed treatment facility, that to the best of my knowledge, the above-described waste material was managed in compliance with all applicable laws, regulations, permits and licenses on the date listed above.

Becky Sumner

CWMNW RECORDS DEPARTMENT

Date:

09/18/13



CHEMICAL WASTE MANAGEMENT OF THE NW

17629 Cedar Springs Lane
Arlington, OR 97812
(541) 454-2643
(541) 454-3279 Fax

PORT OF TACOMA
WAD001882984
3400 TAYLOR WAY
TACOMA WA 98421

CERTIFICATE OF DISPOSAL

Chemical Waste Management of the Northwest, Inc., ORD089452353, has received the following waste material:

GENERATOR:	PORT OF TACOMA
MANIFEST #:	011870118JJK
CWM TRACKING ID:	428041-01
PROFILE #:	OR321468
LINE ITEM:	9b.1
QUANTITY:	1 DT
RECEIVED DATE:	09/11/13
DISPOSAL PROCESS(ES):	LANDFILL
FINAL DISPOSAL LOCATION:	LANDFILL 13
DISPOSAL DATE:	09/11/13

I certify, on behalf of the above listed treatment facility, that to the best of my knowledge, the above-described waste material was managed in compliance with all applicable laws, regulations, permits and licenses on the date listed above.

Becky Sumner

CWMNW RECORDS DEPARTMENT

Date: 09/18/13



CHEMICAL WASTE MANAGEMENT OF THE NW

17629 Cedar Springs Lane
Arlington, OR 97812
(541) 454-2643
(541) 454-3279 Fax

PORT OF TACOMA
WAD001882984
3400 TAYLOR WAY
TACOMA WA 98421

CERTIFICATE OF DISPOSAL

Chemical Waste Management of the Northwest, Inc., ORD089452353, has received the following waste material:

GENERATOR:	PORT OF TACOMA
MANIFEST #:	011870114JJK
CWM TRACKING ID:	428043-01
PROFILE #:	OR321468
LINE ITEM:	9b.1
QUANTITY:	1 DT
RECEIVED DATE:	09/11/13
DISPOSAL PROCESS(ES):	LANDFILL
FINAL DISPOSAL LOCATION:	LANDFILL 13
DISPOSAL DATE:	09/11/13

I certify, on behalf of the above listed treatment facility, that to the best of my knowledge, the above-described waste material was managed in compliance with all applicable laws, regulations, permits and licenses on the date listed above.

Becky Sumner

CWMNW RECORDS DEPARTMENT

Date: 09/18/13



CHEMICAL WASTE MANAGEMENT OF THE NW

17629 Cedar Springs Lane
Arlington, OR 97812
(541) 454-2643
(541) 454-3279 Fax

PORT OF TACOMA
WAD001882984
3400 TAYLOR WAY
TACOMA WA 98421

CERTIFICATE OF DISPOSAL

Chemical Waste Management of the Northwest, Inc., ORD089452353, has received the following waste material:

GENERATOR:	PORT OF TACOMA
MANIFEST #:	011870138JJK
CWM TRACKING ID:	428066-01
PROFILE #:	OR321468
LINE ITEM:	9b.1
QUANTITY:	1 DT
RECEIVED DATE:	09/12/13
DISPOSAL PROCESS(ES):	LANDFILL
FINAL DISPOSAL LOCATION:	LANDFILL 13
DISPOSAL DATE:	09/12/13

I certify, on behalf of the above listed treatment facility, that to the best of my knowledge, the above-described waste material was managed in compliance with all applicable laws, regulations, permits and licenses on the date listed above.

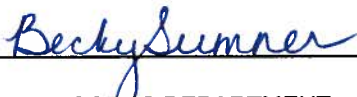

CWMNW RECORDS DEPARTMENT

Date: 09/19/13



CHEMICAL WASTE MANAGEMENT OF THE NW

17629 Cedar Springs Lane
Arlington, OR 97812
(541) 454-2643
(541) 454-3279 Fax

PORT OF TACOMA
WAD001882984
3400 TAYLOR WAY
TACOMA WA 98421

CERTIFICATE OF DISPOSAL

Chemical Waste Management of the Northwest, Inc., ORD089452353, has received the following waste material:

GENERATOR:	PORT OF TACOMA
MANIFEST #:	011870113JJK
CWM TRACKING ID:	428067-01
PROFILE #:	OR321468
LINE ITEM:	9b.1
QUANTITY:	1 DT
RECEIVED DATE:	09/12/13
DISPOSAL PROCESS(ES):	LANDFILL
FINAL DISPOSAL LOCATION:	LANDFILL 13
DISPOSAL DATE:	09/12/13

I certify, on behalf of the above listed treatment facility, that to the best of my knowledge, the above-described waste material was managed in compliance with all applicable laws, regulations, permits and licenses on the date listed above.



CWMNW RECORDS DEPARTMENT

Date: 09/19/13



CHEMICAL WASTE MANAGEMENT OF THE NW

17629 Cedar Springs Lane
Arlington, OR 97812
(541) 454-2643
(541) 454-3279 Fax

PORT OF TACOMA
WAD001882984
3400 TAYLOR WAY
TACOMA WA 98421

CERTIFICATE OF DISPOSAL

Chemical Waste Management of the Northwest, Inc., ORD089452353, has received the following waste material:

GENERATOR:	PORT OF TACOMA
MANIFEST #:	011870112JJK
CWM TRACKING ID:	428074-01
PROFILE #:	OR321468
LINE ITEM:	9b.1
QUANTITY:	1 DT
RECEIVED DATE:	09/12/13
DISPOSAL PROCESS(ES):	LANDFILL
FINAL DISPOSAL LOCATION:	LANDFILL 13
DISPOSAL DATE:	09/12/13

I certify, on behalf of the above listed treatment facility, that to the best of my knowledge, the above-described waste material was managed in compliance with all applicable laws, regulations, permits and licenses on the date listed above.

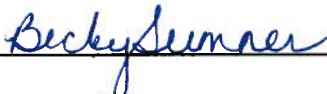

CWMNW RECORDS DEPARTMENT

Date: 09/19/13



CHEMICAL WASTE MANAGEMENT OF THE NW

17629 Cedar Springs Lane
Arlington, OR 97812
(541) 454-2643
(541) 454-3279 Fax

PORT OF TACOMA
WAD001882984
3400 TAYLOR WAY
TACOMA WA 98421

CERTIFICATE OF DISPOSAL

Chemical Waste Management of the Northwest, Inc., ORD089452353, has received the following waste material:

GENERATOR:	PORT OF TACOMA
MANIFEST #:	011870141JJK
CWM TRACKING ID:	428080-01
PROFILE #:	OR321468
LINE ITEM:	9b.1
QUANTITY:	1 DT
RECEIVED DATE:	09/12/13
DISPOSAL PROCESS(ES):	LANDFILL
FINAL DISPOSAL LOCATION:	LANDFILL 13
DISPOSAL DATE:	09/12/13

I certify, on behalf of the above listed treatment facility, that to the best of my knowledge, the above-described waste material was managed in compliance with all applicable laws, regulations, permits and licenses on the date listed above.



CWMNW RECORDS DEPARTMENT

Date: 09/19/13



CHEMICAL WASTE MANAGEMENT OF THE NW

17629 Cedar Springs Lane
Arlington, OR 97812
(541) 454-2643
(541) 454-3279 Fax

PORT OF TACOMA
WAD001882984
3400 TAYLOR WAY
TACOMA WA 98421

CERTIFICATE OF DISPOSAL

Chemical Waste Management of the Northwest, Inc., ORD089452353, has received the following waste material:

GENERATOR:	PORT OF TACOMA
MANIFEST #:	011870142JJK
CWM TRACKING ID:	428081-01
PROFILE #:	OR321468
LINE ITEM:	9b.1
QUANTITY:	1 DT
RECEIVED DATE:	09/12/13
DISPOSAL PROCESS(ES):	LANDFILL
FINAL DISPOSAL LOCATION:	LANDFILL 13
DISPOSAL DATE:	09/12/13

I certify, on behalf of the above listed treatment facility, that to the best of my knowledge, the above-described waste material was managed in compliance with all applicable laws, regulations, permits and licenses on the date listed above.

Becky Sumner

CWMNW RECORDS DEPARTMENT

Date: 09/19/13



CHEMICAL WASTE MANAGEMENT OF THE NW

17629 Cedar Springs Lane
Arlington, OR 97812
(541) 454-2643
(541) 454-3279 Fax

PORT OF TACOMA
WAD001882984
3400 TAYLOR WAY
TACOMA WA 98421

CERTIFICATE OF DISPOSAL

Chemical Waste Management of the Northwest, Inc., ORD089452353, has received the following waste material:

GENERATOR:	PORT OF TACOMA
MANIFEST #:	011870111JJK
CWM TRACKING ID:	428084-01
PROFILE #:	OR321468
LINE ITEM:	9b.1
QUANTITY:	1 DT
RECEIVED DATE:	09/12/13
DISPOSAL PROCESS(ES):	LANDFILL
FINAL DISPOSAL LOCATION:	LANDFILL 13
DISPOSAL DATE:	09/12/13

I certify, on behalf of the above listed treatment facility, that to the best of my knowledge, the above-described waste material was managed in compliance with all applicable laws, regulations, permits and licenses on the date listed above.



CWMNW RECORDS DEPARTMENT

Date: 09/19/13



CHEMICAL WASTE MANAGEMENT OF THE NW
17629 Cedar Springs Lane
Arlington, OR 97812
(541) 454-2643
(541) 454-3279 Fax

PORT OF TACOMA
WAD001882984
3400 TAYLOR WAY
TACOMA WA 98421

CERTIFICATE OF DISPOSAL

Chemical Waste Management of the Northwest, Inc., ORD089452353, has received the following waste material:

GENERATOR:	PORT OF TACOMA
MANIFEST #:	011870143JJK
CWM TRACKING ID:	428085-01
PROFILE #:	OR321468
LINE ITEM:	9b.1
QUANTITY:	1 DT
RECEIVED DATE:	09/12/13
DISPOSAL PROCESS(ES):	LANDFILL
FINAL DISPOSAL LOCATION:	LANDFILL 13
DISPOSAL DATE:	09/12/13

I certify, on behalf of the above listed treatment facility, that to the best of my knowledge, the above-described waste material was managed in compliance with all applicable laws, regulations, permits and licenses on the date listed above.



CWMNW RECORDS DEPARTMENT
Date: 09/19/13



CHEMICAL WASTE MANAGEMENT OF THE NW
17629 Cedar Springs Lane
Arlington, OR 97812
(541) 454-2643
(541) 454-3279 Fax

PORT OF TACOMA
WAD001882984
3400 TAYLOR WAY
TACOMA WA 98421

CERTIFICATE OF DISPOSAL

Chemical Waste Management of the Northwest, Inc., ORD089452353, has received the following waste material:

GENERATOR:	PORT OF TACOMA
MANIFEST #:	011870144JJK
CWM TRACKING ID:	428086-01
PROFILE #:	OR321468
LINE ITEM:	9b.1
QUANTITY:	1 DT
RECEIVED DATE:	09/12/13
DISPOSAL PROCESS(ES):	LANDFILL
FINAL DISPOSAL LOCATION:	LANDFILL 13
DISPOSAL DATE:	09/12/13

I certify, on behalf of the above listed treatment facility, that to the best of my knowledge, the above-described waste material was managed in compliance with all applicable laws, regulations, permits and licenses on the date listed above.



CWMNW RECORDS DEPARTMENT

Date: 09/19/13



CHEMICAL WASTE MANAGEMENT OF THE NW

17629 Cedar Springs Lane
Arlington, OR 97812
(541) 454-2643
(541) 454-3279 Fax

PORT OF TACOMA
WAD001882984
3400 TAYLOR WAY
TACOMA WA 98421

CERTIFICATE OF DISPOSAL

Chemical Waste Management of the Northwest, Inc., ORD089452353, has received the following waste material:

GENERATOR:	PORT OF TACOMA
MANIFEST #:	011870146JJK
CWM TRACKING ID:	428089-01
PROFILE #:	OR321468
LINE ITEM:	9b.1
QUANTITY:	1 DT
RECEIVED DATE:	09/12/13
DISPOSAL PROCESS(ES):	LANDFILL
FINAL DISPOSAL LOCATION:	LANDFILL 13
DISPOSAL DATE:	09/12/13

I certify, on behalf of the above listed treatment facility, that to the best of my knowledge, the above-described waste material was managed in compliance with all applicable laws, regulations, permits and licenses on the date listed above.



CWMNW RECORDS DEPARTMENT

Date: 09/19/13



CHEMICAL WASTE MANAGEMENT OF THE NW

17629 Cedar Springs Lane
Arlington, OR 97812
(541) 454-2643
(541) 454-3279 Fax

PORT OF TACOMA
WAD001882984
3400 TAYLOR WAY
TACOMA WA 98421

CERTIFICATE OF DISPOSAL

Chemical Waste Management of the Northwest, Inc., ORD089452353, has received the following waste material:

GENERATOR:	PORT OF TACOMA
MANIFEST #:	011870145JJK
CWM TRACKING ID:	428091-01
PROFILE #:	OR321468
LINE ITEM:	9b.1
QUANTITY:	1 DT
RECEIVED DATE:	09/12/13
DISPOSAL PROCESS(ES):	LANDFILL
FINAL DISPOSAL LOCATION:	LANDFILL 13
DISPOSAL DATE:	09/12/13

I certify, on behalf of the above listed treatment facility, that to the best of my knowledge, the above-described waste material was managed in compliance with all applicable laws, regulations, permits and licenses on the date listed above.



CWMNW RECORDS DEPARTMENT

Date: 09/19/13



CHEMICAL WASTE MANAGEMENT OF THE NW

17629 Cedar Springs Lane
Arlington, OR 97812
(541) 454-2643
(541) 454-3279 Fax

PORT OF TACOMA
WAD001882984
3400 TAYLOR WAY
TACOMA WA 98421

CERTIFICATE OF DISPOSAL

Chemical Waste Management of the Northwest, Inc., ORD089452353, has received the following waste material:

GENERATOR:	PORT OF TACOMA
MANIFEST #:	011870139JJK
CWM TRACKING ID:	42810701
PROFILE #:	OR321468
LINE ITEM:	9b.1
QUANTITY:	1 DT
RECEIVED DATE:	09/13/13
DISPOSAL PROCESS(ES):	LANDFILL
FINAL DISPOSAL LOCATION:	LANDFILL 13
DISPOSAL DATE:	09/13/13

I certify, on behalf of the above listed treatment facility, that to the best of my knowledge, the above-described waste material was managed in compliance with all applicable laws, regulations, permits and licenses on the date listed above.

CWMNW RECORDS DEPARTMENT

Date: 09/19/13



CHEMICAL WASTE MANAGEMENT OF THE NW

17629 Cedar Springs Lane
Arlington, OR 97812
(541) 454-2643
(541) 454-3279 Fax

PORT OF TACOMA
WAD001882984
3400 TAYLOR WAY
TACOMA WA 98421

CERTIFICATE OF DISPOSAL

Chemical Waste Management of the Northwest, Inc., ORD089452353, has received the following waste material:

GENERATOR:	PORT OF TACOMA
MANIFEST #:	011870151JJK
CWM TRACKING ID:	42811201
PROFILE #:	OR321468
LINE ITEM:	9b.1
QUANTITY:	1 DT
RECEIVED DATE:	09/13/13
DISPOSAL PROCESS(ES):	LANDFILL
FINAL DISPOSAL LOCATION:	LANDFILL 13
DISPOSAL DATE:	09/13/13

I certify, on behalf of the above listed treatment facility, that to the best of my knowledge, the above-described waste material was managed in compliance with all applicable laws, regulations, permits and licenses on the date listed above.

CWMNW RECORDS DEPARTMENT

Date: 09/19/13



CHEMICAL WASTE MANAGEMENT OF THE NW

17629 Cedar Springs Lane
Arlington, OR 97812
(541) 454-2643
(541) 454-3279 Fax

PORT OF TACOMA
WAD001882984
3400 TAYLOR WAY
TACOMA WA 98421

CERTIFICATE OF DISPOSAL

Chemical Waste Management of the Northwest, Inc., ORD089452353, has received the following waste material:

GENERATOR:	PORT OF TACOMA
MANIFEST #:	011870150JJK
CWM TRACKING ID:	428 1301
PROFILE #:	OR321468
LINE ITEM:	9b.1
QUANTITY:	1 DT
RECEIVED DATE:	09/13/13
DISPOSAL PROCESS(ES):	LANDFILL
FINAL DISPOSAL LOCATION:	LANDFILL 13
DISPOSAL DATE:	09/13/13

I certify, on behalf of the above listed treatment facility, that to the best of my knowledge, the above-described waste material was managed in compliance with all applicable laws, regulations, permits and licenses on the date listed above.

CWMNW RECORDS DEPARTMENT

Date: 09/19/13



CHEMICAL WASTE MANAGEMENT OF THE NW

17629 Cedar Springs Lane
Arlington, OR 97812
(541) 454-2643
(541) 454-3279 Fax

PORT OF TACOMA
WAD001882984
3400 TAYLOR WAY
TACOMA WA 98421

CERTIFICATE OF DISPOSAL

Chemical Waste Management of the Northwest, Inc., ORD089452353, has received the following waste material:

GENERATOR:	PORT OF TACOMA
MANIFEST #:	011870149JJK
CWM TRACKING ID:	42812001
PROFILE #:	OR321468
LINE ITEM:	9b.1
QUANTITY:	1 DT
RECEIVED DATE:	09/13/13
DISPOSAL PROCESS(ES):	LANDFILL
FINAL DISPOSAL LOCATION:	LANDFILL 13
DISPOSAL DATE:	09/13/13

I certify, on behalf of the above listed treatment facility, that to the best of my knowledge, the above-described waste material was managed in compliance with all applicable laws, regulations, permits and licenses on the date listed above.

CWMNW RECORDS DEPARTMENT

Date: 09/19/13



CHEMICAL WASTE MANAGEMENT OF THE NW

17629 Cedar Springs Lane
Arlington, OR 97812
(541) 454-2643
(541) 454-3279 Fax

PORT OF TACOMA
WAD001882984
3400 TAYLOR WAY
TACOMA WA 98421

CERTIFICATE OF DISPOSAL

Chemical Waste Management of the Northwest, Inc., ORD089452353, has received the following waste material:

GENERATOR:	PORT OF TACOMA
MANIFEST #:	011870154JJK
CWM TRACKING ID:	42812201
PROFILE #:	OR321468
LINE ITEM:	9b.1
QUANTITY:	1 DT
RECEIVED DATE:	09/13/13
DISPOSAL PROCESS(ES):	LANDFILL
FINAL DISPOSAL LOCATION:	LANDFILL 13
DISPOSAL DATE:	09/13/13

I certify, on behalf of the above listed treatment facility, that to the best of my knowledge, the above-described waste material was managed in compliance with all applicable laws, regulations, permits and licenses on the date listed above.

CWMNW RECORDS DEPARTMENT

Date: 09/19/13



CHEMICAL WASTE MANAGEMENT OF THE NW

17629 Cedar Springs Lane
Arlington, OR 97812
(541) 454-2643
(541) 454-3279 Fax

PORT OF TACOMA
WAD001882984
3400 TAYLOR WAY
TACOMA WA 98421

CERTIFICATE OF DISPOSAL

Chemical Waste Management of the Northwest, Inc., ORD089452353, has received the following waste material:

GENERATOR:	PORT OF TACOMA
MANIFEST #:	011870152JJK
CWM TRACKING ID:	42812401
PROFILE #:	OR321468
LINE ITEM:	9b.1
QUANTITY:	1 DT
RECEIVED DATE:	09/13/13
DISPOSAL PROCESS(ES):	LANDFILL
FINAL DISPOSAL LOCATION:	LANDFILL 13
DISPOSAL DATE:	09/13/13

I certify, on behalf of the above listed treatment facility, that to the best of my knowledge, the above-described waste material was managed in compliance with all applicable laws, regulations, permits and licenses on the date listed above.

CWMNW RECORDS DEPARTMENT

Date: 09/19/13



CHEMICAL WASTE MANAGEMENT OF THE NW

17629 Cedar Springs Lane
Arlington, OR 97812
(541) 454-2643
(541) 454-3279 Fax

PORT OF TACOMA
WAD001882984
3400 TAYLOR WAY
TACOMA WA 98421

CERTIFICATE OF DISPOSAL

Chemical Waste Management of the Northwest, Inc., ORD089452353, has received the following waste material:

GENERATOR:	PORT OF TACOMA
MANIFEST #:	011070153JJK
CWM TRACKING ID:	42812601
PROFILE #:	OR321468
LINE ITEM:	9b.1
QUANTITY:	1 DT
RECEIVED DATE:	09/13/13
DISPOSAL PROCESS(ES):	LANDFILL
FINAL DISPOSAL LOCATION:	LANDFILL 13
DISPOSAL DATE:	09/13/13

I certify, on behalf of the above listed treatment facility, that to the best of my knowledge, the above-described waste material was managed in compliance with all applicable laws, regulations, permits and licenses on the date listed above.

CWMNW RECORDS DEPARTMENT

Date: 09/19/13



CHEMICAL WASTE MANAGEMENT OF THE NW

17629 Cedar Springs Lane
Arlington, OR 97812
(541) 454-2643
(541) 454-3279 Fax

PORT OF TACOMA
WAD001882984
3400 TAYLOR WAY
TACOMA WA 98421

CERTIFICATE OF DISPOSAL

Chemical Waste Management of the Northwest, Inc., ORD089452353, has received the following waste material:

GENERATOR:	PORT OF TACOMA
MANIFEST #:	011870147JJK
CWM TRACKING ID:	42812701
PROFILE #:	OR321468
LINE ITEM:	9b.1
QUANTITY:	1 DT
RECEIVED DATE:	09/13/13
DISPOSAL PROCESS(ES):	LANDFILL
FINAL DISPOSAL LOCATION:	LANDFILL 13
DISPOSAL DATE:	09/13/13

I certify, on behalf of the above listed treatment facility, that to the best of my knowledge, the above-described waste material was managed in compliance with all applicable laws, regulations, permits and licenses on the date listed above.

CWMNW RECORDS DEPARTMENT

Date: 09/19/13



CHEMICAL WASTE MANAGEMENT OF THE NW

17629 Cedar Springs Lane
Arlington, OR 97812
(541) 454-2643
(541) 454-3279 Fax

PORT OF TACOMA
WAD001882984
3400 TAYLOR WAY
TACOMA WA 98421

CERTIFICATE OF DISPOSAL

Chemical Waste Management of the Northwest, Inc., ORD089452353, has received the following waste material:

GENERATOR:	PORT OF TACOMA
MANIFEST #:	011870148JJK
CWM TRACKING ID:	42812801
PROFILE #:	OR321468
LINE ITEM:	9b.1
QUANTITY:	1 DT
RECEIVED DATE:	09/13/13
DISPOSAL PROCESS(ES):	LANDFILL
FINAL DISPOSAL LOCATION:	LANDFILL 13
DISPOSAL DATE:	09/13/13

I certify, on behalf of the above listed treatment facility, that to the best of my knowledge, the above-described waste material was managed in compliance with all applicable laws, regulations, permits and licenses on the date listed above.

CWMNW RECORDS DEPARTMENT

Date: 09/19/13



CHEMICAL WASTE MANAGEMENT OF THE NW

17629 Cedar Springs Lane
Arlington, OR 97812
(541) 454-2643
(541) 454-3279 Fax

PORT OF TACOMA
WAD001882984
3400 TAYLOR WAY
TACOMA WA 98421

CERTIFICATE OF DISPOSAL

Chemical Waste Management of the Northwest, Inc., ORD089452353, has received the following waste material:

GENERATOR:	PORT OF TACOMA
MANIFEST #:	011870155JJK
CWM TRACKING ID:	42812901
PROFILE #:	OR321468
LINE ITEM:	9b.1
QUANTITY:	1 DT
RECEIVED DATE:	09/13/13
DISPOSAL PROCESS(ES):	LANDFILL
FINAL DISPOSAL LOCATION:	LANDFILL 13
DISPOSAL DATE:	09/13/13

I certify, on behalf of the above listed treatment facility, that to the best of my knowledge, the above-described waste material was managed in compliance with all applicable laws, regulations, permits and licenses on the date listed above.

CWMNW RECORDS DEPARTMENT

Date: 09/19/13



CHEMICAL WASTE MANAGEMENT OF THE NW

17629 Cedar Springs Lane
Arlington, OR 97812
(541) 454-2643
(541) 454-3279 Fax

PORT OF TACOMA
WAD001882984
3400 TAYLOR WAY
TACOMA WA 98421

CERTIFICATE OF DISPOSAL

Chemical Waste Management of the Northwest, Inc., ORD089452353, has received the following waste material:

GENERATOR:	PORT OF TACOMA
MANIFEST #:	011870156JJK
CWM TRACKING ID:	42713201
PROFILE #:	OR321468
LINE ITEM:	9b.1
QUANTITY:	1 D ³
RECEIVED DATE:	09/13/13
DISPOSAL PROCESS(ES):	LANDFILL
FINAL DISPOSAL LOCATION:	LANDFILL 13
DISPOSAL DATE:	09/13/13

I certify, on behalf of the above listed treatment facility, that to the best of my knowledge, the above-described waste material was managed in compliance with all applicable laws, regulations, permits and licenses on the date listed above.

CWMNW RECORDS DEPARTMENT

Date: 09/19/13



CHEMICAL WASTE MANAGEMENT OF THE NW

17629 Cedar Springs Lane
Arlington, OR 97812
(541) 454-2643
(541) 454-3279 Fax

SPECTRUM GLASS CO INC
WAD086248978
24105 WOODINVILLE SNOHOMISH RD
WOODINVILLE WA 98072-0646

CERTIFICATE OF DISPOSAL

Chemical Waste Management of the Northwest, Inc., ORD089452353, has received the following waste material:

GENERATOR: SPECTRUM GLASS CO INC
MANIFEST #: 011880959JJK
CWM TRACKING ID: 428181-01
PROFILE #: OR323153
LINE ITEM: 9b.1
QUANTITY: 1 DT
RECEIVED DATE: 09/16/13

DISPOSAL PROCESS(ES): STABILIZATION FOLLOWED BY LANDFILL
FINAL DISPOSAL LOCATION: LANDFILL 14
DISPOSAL DATE: 09/18/13

I certify, on behalf of the above listed treatment facility, that to the best of my knowledge, the above-described waste material was managed in compliance with all applicable laws, regulations, permits and licenses on the date listed above.



CWMNW RECORDS DEPARTMENT

Date: 09/20/13



CHEMICAL WASTE MANAGEMENT OF THE NW

17629 Cedar Springs Lane
Arlington, OR 97812
(541) 454-2643
(541) 454-3279 Fax

PORT OF TACOMA
WAD001882984
3400 TAYLOR WAY
TACOMA WA 98421

CERTIFICATE OF DISPOSAL

Chemical Waste Management of the Northwest, Inc., ORD089452353, has received the following waste material:

GENERATOR:	PORT OF TACOMA
MANIFEST #:	011870159JJK
CWM TRACKING ID:	428158-01
PROFILE #:	OR321468
LINE ITEM:	9b.1
QUANTITY:	1 DT
RECEIVED DATE:	09/16/13
DISPOSAL PROCESS(ES):	LANDFILL
FINAL DISPOSAL LOCATION:	LANDFILL 13
DISPOSAL DATE:	09/16/13

I certify, on behalf of the above listed treatment facility, that to the best of my knowledge, the above-described waste material was managed in compliance with all applicable laws, regulations, permits and licenses on the date listed above.

Becky Sumner

CWMNW RECORDS DEPARTMENT

Date: 09/19/13



CHEMICAL WASTE MANAGEMENT OF THE NW

17629 Cedar Springs Lane
Arlington, OR 97812
(541) 454-2643
(541) 454-3279 Fax

PORT OF TACOMA
WAD001882984
3400 TAYLOR WAY
TACOMA WA 98421

CERTIFICATE OF DISPOSAL

Chemical Waste Management of the Northwest, Inc., ORD089452353, has received the following waste material:

GENERATOR:	PORT OF TACOMA
MANIFEST #:	011870158JJK
CWM TRACKING ID:	428159-01
PROFILE #:	OR321468
LINE ITEM:	9b.1
QUANTITY:	1 DT
RECEIVED DATE:	09/16/13
DISPOSAL PROCESS(ES):	LANDFILL
FINAL DISPOSAL LOCATION:	LANDFILL 13
DISPOSAL DATE:	09/16/13

I certify, on behalf of the above listed treatment facility, that to the best of my knowledge, the above-described waste material was managed in compliance with all applicable laws, regulations, permits and licenses on the date listed above.

Becky Sumner

CWMNW RECORDS DEPARTMENT

Date: 09/19/13



CHEMICAL WASTE MANAGEMENT OF THE NW

17629 Cedar Springs Lane
Arlington, OR 97812
(541) 454-2643
(541) 454-3279 Fax

PORT OF TACOMA
WAD001882984
3400 TAYLOR WAY
TACOMA WA 98421

CERTIFICATE OF DISPOSAL

Chemical Waste Management of the Northwest, Inc., ORD089452353, has received the following waste material:

GENERATOR:	PORT OF TACOMA
MANIFEST #:	011880892JJK
CWM TRACKING ID:	428165-01
PROFILE #:	OR321468
LINE ITEM:	9b.1
QUANTITY:	1 DT
RECEIVED DATE:	09/16/13
DISPOSAL PROCESS(ES):	LANDFILL
FINAL DISPOSAL LOCATION:	LANDFILL 13
DISPOSAL DATE:	09/16/13

I certify, on behalf of the above listed treatment facility, that to the best of my knowledge, the above-described waste material was managed in compliance with all applicable laws, regulations, permits and licenses on the date listed above.

Becky Sumner

CWMNW RECORDS DEPARTMENT

Date: 09/19/13



CHEMICAL WASTE MANAGEMENT OF THE NW

17629 Cedar Springs Lane
Arlington, OR 97812
(541) 454-2643
(541) 454-3279 Fax

PORT OF TACOMA
WAD001882984
3400 TAYLOR WAY
TACOMA WA 98421

CERTIFICATE OF DISPOSAL

Chemical Waste Management of the Northwest, Inc., ORD089452353, has received the following waste material:

GENERATOR:	PORT OF TACOMA
MANIFEST #:	011880899JJK
CWM TRACKING ID:	428166-01
PROFILE #:	OR321468
LINE ITEM:	9b.1
QUANTITY:	1 DT
RECEIVED DATE:	09/16/13
DISPOSAL PROCESS(ES):	LANDFILL
FINAL DISPOSAL LOCATION:	LANDFILL 13
DISPOSAL DATE:	09/16/13

I certify, on behalf of the above listed treatment facility, that to the best of my knowledge, the above-described waste material was managed in compliance with all applicable laws, regulations, permits and licenses on the date listed above.



CWMNW RECORDS DEPARTMENT

Date: 09/19/13



CHEMICAL WASTE MANAGEMENT OF THE NW

17629 Cedar Springs Lane
Arlington, OR 97812
(541) 454-2643
(541) 454-3279 Fax

PORT OF TACOMA
WAD001882984
3400 TAYLOR WAY
TACOMA WA 98421

CERTIFICATE OF DISPOSAL

Chemical Waste Management of the Northwest, Inc., ORD089452353, has received the following waste material:

GENERATOR:	PORT OF TACOMA
MANIFEST #:	011880897JJK
CWM TRACKING ID:	428167-01
PROFILE #:	OR321468
LINE ITEM:	9b.1
QUANTITY:	1 DT
RECEIVED DATE:	09/16/13
DISPOSAL PROCESS(ES):	LANDFILL
FINAL DISPOSAL LOCATION:	LANDFILL 13
DISPOSAL DATE:	09/16/13

I certify, on behalf of the above listed treatment facility, that to the best of my knowledge, the above-described waste material was managed in compliance with all applicable laws, regulations, permits and licenses on the date listed above.



CWMNW RECORDS DEPARTMENT

Date: 09/19/13



CHEMICAL WASTE MANAGEMENT OF THE NW

17629 Cedar Springs Lane
Arlington, OR 97812
(541) 454-2643
(541) 454-3279 Fax

PORT OF TACOMA
WAD001882984
3400 TAYLOR WAY
TACOMA WA 98421

CERTIFICATE OF DISPOSAL

Chemical Waste Management of the Northwest, Inc., ORD089452353, has received the following waste material:

GENERATOR:	PORT OF TACOMA
MANIFEST #:	011870157JJK
CWM TRACKING ID:	428168-01
PROFILE #:	OR321468
LINE ITEM:	9b.1
QUANTITY:	1 DT
RECEIVED DATE:	09/16/13
DISPOSAL PROCESS(ES):	LANDFILL
FINAL DISPOSAL LOCATION:	LANDFILL 13
DISPOSAL DATE:	09/16/13

I certify, on behalf of the above listed treatment facility, that to the best of my knowledge, the above-described waste material was managed in compliance with all applicable laws, regulations, permits and licenses on the date listed above.

Becky Sumner

CWMNW RECORDS DEPARTMENT

Date: 09/19/13



CHEMICAL WASTE MANAGEMENT OF THE NW

17629 Cedar Springs Lane
Arlington, OR 97812
(541) 454-2643
(541) 454-3279 Fax

PORT OF TACOMA
WAD001882984
3400 TAYLOR WAY
TACOMA WA 98421

CERTIFICATE OF DISPOSAL

Chemical Waste Management of the Northwest, Inc., ORD089452353, has received the following waste material:

GENERATOR:	PORT OF TACOMA
MANIFEST #:	011880895JJK
CWM TRACKING ID:	428170-01
PROFILE #:	OR321468
LINE ITEM:	9b.1
QUANTITY:	1 DT
RECEIVED DATE:	09/16/13
DISPOSAL PROCESS(ES):	LANDFILL
FINAL DISPOSAL LOCATION:	LANDFILL 13
DISPOSAL DATE:	09/16/13

I certify, on behalf of the above listed treatment facility, that to the best of my knowledge, the above-described waste material was managed in compliance with all applicable laws, regulations, permits and licenses on the date listed above.

Becky Sumner

CWMNW RECORDS DEPARTMENT

Date: 09/19/13



CHEMICAL WASTE MANAGEMENT OF THE NW

17629 Cedar Springs Lane
Arlington, OR 97812
(541) 454-2643
(541) 454-3279 Fax

PORT OF TACOMA
WAD001882984
3400 TAYLOR WAY
TACOMA WA 98421

CERTIFICATE OF DISPOSAL

Chemical Waste Management of the Northwest, Inc., ORD089452353, has received the following waste material:

GENERATOR:	PORT OF TACOMA
MANIFEST #:	011880896JJK
CWM TRACKING ID:	428171-01
PROFILE #:	OR321468
LINE ITEM:	9b.1
QUANTITY:	1 DT
RECEIVED DATE:	09/16/13
DISPOSAL PROCESS(ES):	LANDFILL
FINAL DISPOSAL LOCATION:	LANDFILL 13
DISPOSAL DATE:	09/16/13

I certify, on behalf of the above listed treatment facility, that to the best of my knowledge, the above-described waste material was managed in compliance with all applicable laws, regulations, permits and licenses on the date listed above.

Becky Sumner

_____ CWMNW RECORDS DEPARTMENT

Date: 09/19/13



CHEMICAL WASTE MANAGEMENT OF THE NW

17629 Cedar Springs Lane
Arlington, OR 97812
(541) 454-2643
(541) 454-3279 Fax

PORT OF TACOMA
WAD001882984
3400 TAYLOR WAY
TACOMA WA 98421

CERTIFICATE OF DISPOSAL

Chemical Waste Management of the Northwest, Inc., ORD089452353, has received the following waste material:

GENERATOR:	PORT OF TACOMA
MANIFEST #:	011880893JJK
CWM TRACKING ID:	428173-01
PROFILE #:	OR321468
LINE ITEM:	9b.1
QUANTITY:	1 DT
RECEIVED DATE:	09/16/13
DISPOSAL PROCESS(ES):	LANDFILL
FINAL DISPOSAL LOCATION:	LANDFILL 13
DISPOSAL DATE:	09/16/13

I certify, on behalf of the above listed treatment facility, that to the best of my knowledge, the above-described waste material was managed in compliance with all applicable laws, regulations, permits and licenses on the date listed above.



CWMNW RECORDS DEPARTMENT

Date: 09/19/13



CHEMICAL WASTE MANAGEMENT OF THE NW

17629 Cedar Springs Lane
Arlington, OR 97812
(541) 454-2643
(541) 454-3279 Fax

PORT OF TACOMA
WAD001882984
3400 TAYLOR WAY
TACOMA WA 98421

CERTIFICATE OF DISPOSAL

Chemical Waste Management of the Northwest, Inc., ORD089452353, has received the following waste material:

GENERATOR:	PORT OF TACOMA
MANIFEST #:	011870160JJK
CWM TRACKING ID:	42816201
PROFILE #:	OR321468
LINE ITEM:	9b.1
QUANTITY:	1 DT
RECEIVED DATE:	09/16/13
DISPOSAL PROCESS(ES):	LANDFILL
FINAL DISPOSAL LOCATION:	LANDFILL 13
DISPOSAL DATE:	09/16/13

I certify, on behalf of the above listed treatment facility, that to the best of my knowledge, the above-described waste material was managed in compliance with all applicable laws, regulations, permits and licenses on the date listed above.

CWMNW RECORDS DEPARTMENT

Date: 09/19/13



CHEMICAL WASTE MANAGEMENT OF THE NW

17629 Cedar Springs Lane
Arlington, OR 97812
(541) 454-2643
(541) 454-3279 Fax

PORT OF TACOMA
WAD001882984
3400 TAYLOR WAY
TACOMA WA 98421

CERTIFICATE OF DISPOSAL

Chemical Waste Management of the Northwest, Inc., ORD089452353, has received the following waste material:

GENERATOR:	PORT OF TACOMA
MANIFEST #:	011880898JJK
CWM TRACKING ID:	42816901
PROFILE #:	OR321468
LINE ITEM:	9b.1
QUANTITY:	1 DT
RECEIVED DATE:	09/16/13
DISPOSAL PROCESS(ES):	LANDFILL
FINAL DISPOSAL LOCATION:	LANDFILL 13
DISPOSAL DATE:	09/16/13

I certify, on behalf of the above listed treatment facility, that to the best of my knowledge, the above-described waste material was managed in compliance with all applicable laws, regulations, permits and licenses on the date listed above.

Bobbi Jo Galvin

CWMNW RECORDS DEPARTMENT

Date: 09/19/13



CHEMICAL WASTE MANAGEMENT OF THE NW
17629 Cedar Springs Lane
Arlington, OR 97812
541 454 2643

PORT OF TACOMA
WAD001882984
3400 TAYLOR WAY
TACOMA WA 98421

CERTIFICATE OF DISPOSAL

Chemical Waste Management of the Northwest, Inc., ORD089452353, has received the following waste material:

GENERATOR:	PORT OF TACOMA
MANIFEST #:	011880878JJK
CWM TRACKING ID:	42821401
PROFILE #:	OR321468
LINE ITEM:	9b.1
QUANTITY:	1 DT
RECEIVED DATE:	09/17/13
DISPOSAL PROCESS(ES):	LANDFILL
FINAL DISPOSAL LOCATION:	LANDFILL 13
DISPOSAL DATE:	09/17/13

I certify, on behalf of the above listed treatment facility, that to the best of my knowledge, the above-described waste material was managed in compliance with all applicable laws, regulations, permits and licenses on the date listed above.



CWMNW RECORDS DEPARTMENT

Date: 09/19/13



CHEMICAL WASTE MANAGEMENT OF THE NW
 17629 Cedar Springs Lane
 Arlington, OR 97812
 (541) 454-2643
 (541) 454-3279 Fax

PORT OF TACOMA
 WAD001882984
 3400 TAYLOR WAY
 TACOMA WA 98421

CERTIFICATE OF DISPOSAL

Chemical Waste Management of the Northwest, Inc., ORD089452353, has received the following waste material:

GENERATOR:	PORT OF TACOMA	
MANIFEST #:	011880894JJK	
CWM TRACKING ID:	42820601	
PROFILE #:	OR321468	
LINE ITEM:	9b.1	
QUANTITY:	1 DT	
RECEIVED DATE:	09/17/13	
DISPOSAL PROCESS(ES):	LANDFILL	
FINAL DISPOSAL LOCATION:	LANDFILL	13
DISPOSAL DATE:	09/17/13	

I certify, on behalf of the above listed treatment facility, that to the best of my knowledge, the above-described waste material was managed in compliance with all applicable laws, regulations, permits and licenses on the date listed above.

Bobbi Jo Galvin

CWMNW RECORDS DEPARTMENT
 Date: 09/19/13



CHEMICAL WASTE MANAGEMENT OF THE NW

17629 Cedar Springs Lane
Arlington, OR 97812
(541) 454-2643
(541) 454-3279 Fax

PORT OF TACOMA
WAD001882984
3400 TAYLOR WAY
TACOMA WA 98421

CERTIFICATE OF DISPOSAL

Chemical Waste Management of the Northwest, Inc., ORD089452353, has received the following waste material:

GENERATOR:	PORT OF TACOMA
MANIFEST #:	011880888JJK
CWM TRACKING ID:	42820901
PROFILE #:	OR321468
LINE ITEM:	9b.1
QUANTITY:	1 DT
RECEIVED DATE:	09/17/13
DISPOSAL PROCESS(ES):	LANDFILL
FINAL DISPOSAL LOCATION:	LANDFILL 13
DISPOSAL DATE:	09/17/13

I certify, on behalf of the above listed treatment facility, that to the best of my knowledge, the above-described waste material was managed in compliance with all applicable laws, regulations, permits and licenses on the date listed above.



CWMNW RECORDS DEPARTMENT

Date: 09/19/13



CHEMICAL WASTE MANAGEMENT OF THE NW

17629 Cedar Springs Lane
Arlington, OR 97812
(541) 454-2643
(541) 454-3279 Fax

PORT OF TACOMA
WAD001882984
3400 TAYLOR WAY
TACOMA WA 98421

CERTIFICATE OF DISPOSAL

Chemical Waste Management of the Northwest, Inc., ORD089452353, has received the following waste material:

GENERATOR:	PORT OF TACOMA
MANIFEST #:	011880890JJK
CWM TRACKING ID:	42821001
PROFILE #:	OR?21468
LINE ITEM:	9b.1
QUANTITY:	1 DT
RECEIVED DATE:	09/17/13
DISPOSAL PROCESS(ES):	LANDFILL
FINAL DISPOSAL LOCATION:	LANDFILL 13
DISPOSAL DATE:	09/17/13

I certify, on behalf of the above listed treatment facility, that to the best of my knowledge, the above-described waste material was managed in compliance with all applicable laws, regulations, permits and licenses on the date listed above.

Bobbi Jo Galvin

CWMNW RECORDS DEPARTMENT

Date: 09/19/13



CHEMICAL WASTE MANAGEMENT OF THE NW

17629 Cedar Springs Lane
Arlington, OR 97812
(541) 454-2643
(541) 454-3279 Fax

PORT OF TACOMA
WAD001882984
3400 TAYLOR WAY
TACOMA WA 98421

CERTIFICATE OF DISPOSAL

Chemical Waste Management of the Northwest, Inc., ORD089452353, has received the following waste material:

GENERATOR:	PORT OF TACOMA
MANIFEST #:	011880885JJK
CWM TRACKING ID:	42821101
PROFILE #:	OR321468
LINE ITEM:	9b.1
QUANTITY:	1 DT
RECEIVED DATE:	09/17/13
DISPOSAL PROCESS(ES):	LANDFILL
FINAL DISPOSAL LOCATION:	LANDFILL 13
DISPOSAL DATE:	09/17/13

I certify, on behalf of the above listed treatment facility, that to the best of my knowledge, the above-described waste material was managed in compliance with all applicable laws, regulations, permits and licenses on the date listed above.



CWMNW RECORDS DEPARTMENT

Date: 09/19/13



CHEMICAL WASTE MANAGEMENT OF THE NW

17629 Cedar Springs Lane
Arlington, OR 97812
(541) 454-2643
(541) 454-3279 Fax

PORT OF TACOMA
WAD001882984
3400 TAYLOR WAY
TACOMA WA 98421

CERTIFICATE OF DISPOSAL

Chemical Waste Management of the Northwest, Inc., ORD089452353, has received the following waste material:

GENERATOR:	PORT OF TACOMA
MANIFEST #:	011880868JJK
CWM TRACKING ID:	42821301
PROFILE #:	OR321468
LINE ITEM:	9b.1
QUANTITY:	1 DT
RECEIVED DATE:	09/17/13
DISPOSAL PROCESS(ES):	LANDFILL
FINAL DISPOSAL LOCATION:	LANDFILL 13
DISPOSAL DATE:	09/17/13

I certify, on behalf of the above listed treatment facility, that to the best of my knowledge, the above-described waste material was managed in compliance with all applicable laws, regulations, permits and licenses on the date listed above.

Bobbi Galvin

CWMNW RECORDS DEPARTMENT

Date: 09/19/13



CHEMICAL WASTE MANAGEMENT OF THE NW

17629 Cedar Springs Lane
Arlington, OR 97812
(541) 454-2643
(541) 454-3279 Fax

PORT OF TACOMA
WAD001882984
3400 TAYLOR WAY
TACOMA WA 98421

CERTIFICATE OF DISPOSAL

Chemical Waste Management of the Northwest, Inc., ORD089452353, has received the following waste material:

GENERATOR:	PORT OF TACOMA
MANIFEST #:	011880882JJK
CWM TRACKING ID:	42821701
PROFILE #:	OR321468
LINE ITEM:	9b.1
QUANTITY:	1 DT
RECEIVED DATE:	09/17/13
DISPOSAL PROCESS(ES):	LANDFILL
FINAL DISPOSAL LOCATION:	LANDFILL 13
DISPOSAL DATE:	09/17/13

I certify, on behalf of the above listed treatment facility, that to the best of my knowledge, the above-described waste material was managed in compliance with all applicable laws, regulations, permits and licenses on the date listed above.

Bobbi Jo Galvin

CWMNW RECORDS DEPARTMENT
Date: 09/19/13



CHEMICAL WASTE MANAGEMENT OF THE NW

17629 Cedar Springs Lane
Arlington, OR 97812
(541) 454-2643
(541) 454-3279 Fax

PORT OF TACOMA
WAD001882984
3400 TAYLOR WAY
TACOMA WA 98421

CERTIFICATE OF DISPOSAL

Chemical Waste Management of the Northwest, Inc., ORD089452353, has received the following waste material:

GENERATOR:	PORT OF TACOMA
MANIFEST #:	011880880JJK
CWM TRACKING ID:	42822101
PROFILE #:	OR321468
LINE ITEM:	9b.1
QUANTITY:	1 DT
RECEIVED DATE:	09/17/13
DISPOSAL PROCESS(ES):	LANDFILL
FINAL DISPOSAL LOCATION:	LANDFILL 13
DISPOSAL DATE:	09/17/13

I certify, on behalf of the above listed treatment facility, that to the best of my knowledge, the above-described waste material was managed in compliance with all applicable laws, regulations, permits and licenses on the date listed above.

Bebbi Jo Galvin

CWMNW RECORDS DEPARTMENT

Date: 09/19/13



CHEMICAL WASTE MANAGEMENT OF THE NW

17629 Cedar Springs Lane
Arlington, OR 97812
(541) 454-2643
(541) 454-3279 Fax

PORT OF TACOMA
WAD001882984
3400 TAYLOR WAY
TACOMA WA 98421

CERTIFICATE OF DISPOSAL

Chemical Waste Management of the Northwest, Inc., ORD089452353, has received the following waste material:

GENERATOR:	PORT OF TACOMA
MANIFEST #:	011880877JJK
CWM TRACKING ID:	42822201
PROFILE #:	OR:21468
LINE ITEM:	9b.1
QUANTITY:	1 DT
RECEIVED DATE:	09/17/13
DISPOSAL PROCESS(ES):	LANDFILL
FINAL DISPOSAL LOCATION:	LANDFILL 13
DISPOSAL DATE:	09/17/13

I certify, on behalf of the above listed treatment facility, that to the best of my knowledge, the above-described waste material was managed in compliance with all applicable laws, regulations, permits and licenses on the date listed above.

Bobbi Jo Galvin

CWMNW RECORDS DEPARTMENT

Date: 09/19/13





CHEMICAL WASTE MANAGEMENT OF THE NW

17629 Cedar Springs Lane
Arlington, OR 97812
(541) 454-2643
(541) 454-3279 Fax

PORT OF TACOMA
WAD001882984
3400 TAYLOR WAY
TACOMA WA 98421

CERTIFICATE OF DISPOSAL

Chemical Waste Management of the Northwest, Inc., ORD089452353, has received the following waste material:

GENERATOR:	PORT OF TACOMA
MANIFEST #:	011880884JJK
CWM TRACKING ID:	42822301
PROFILE #:	OR321468
LINE ITEM:	9b.1
QUANTITY:	1 DT
RECEIVED DATE:	09/17/13
DISPOSAL PROCESS(ES):	LANDFILL
FINAL DISPOSAL LOCATION:	LANDFILL 13
DISPOSAL DATE:	09/17/13

I certify, on behalf of the above listed treatment facility, that to the best of my knowledge, the above-described waste material was managed in compliance with all applicable laws, regulations, permits and licenses on the date listed above.

Bobbie Balin

CWMNW RECORDS DEPARTMENT

Date: 09/19/13



CHEMICAL WASTE MANAGEMENT OF THE NW
 17629 Cedar Springs Lane
 Arlington, OR 97812
 (541) 454-2643
 (541) 454-3279 Fax

PORT OF TACOMA
 WAD001882984
 3400 TAYLOR WAY
 TACOMA WA 98421

CERTIFICATE OF DISPOSAL

Chemical Waste Management of the Northwest, Inc., ORD089452353, has received the following waste material:

GENERATOR:	PORT OF TACOMA	
MANIFEST #:	011880879JJK	
CWM TRACKING ID:	42822401	
PROFILE #:	OR321468	
LINE ITEM:	9b.1	
QUANTITY:	1 DT	
RECEIVED DATE:	09/17/13	
DISPOSAL PROCESS(ES):	LANDFILL	
FINAL DISPOSAL LOCATION:	LANDFILL	13
DISPOSAL DATE:	09/17/13	

I certify, on behalf of the above listed treatment facility, that to the best of my knowledge, the above-described waste material was managed in compliance with all applicable laws, regulations, permits and licenses on the date listed above.

Bobbi Corwin

CWMNW RECORDS DEPARTMENT
 Date: 09/19/13



CHEMICAL WASTE MANAGEMENT OF THE NW

17629 Cedar Springs Lane
Arlington, OR 97812
(541) 454-2643
(541) 454-3279 Fax

PORT OF TACOMA
WAD001882984
3400 TAYLOR WAY
TACOMA WA 98421

CERTIFICATE OF DISPOSAL

Chemical Waste Management of the Northwest, Inc., ORD089452353, has received the following waste material:

GENERATOR:	PORT OF TACOMA
MANIFEST #:	011880881JJK
CWM TRACKING ID:	42822501
PROFILE #:	OR321468
LINE ITEM:	9b.1
QUANTITY:	1 DT
RECEIVED DATE:	09/17/13
DISPOSAL PROCESS(ES):	LANDFILL
FINAL DISPOSAL LOCATION:	LANDFILL 13
DISPOSAL DATE:	09/17/13

I certify, on behalf of the above listed treatment facility, that to the best of my knowledge, the above-described waste material was managed in compliance with all applicable laws, regulations, permits and licenses on the date listed above.

Bobbi Jo Galvin

CWMNW RECORDS DEPARTMENT

Date: 09/19/13



CHEMICAL WASTE MANAGEMENT OF THE NW

17629 Cedar Springs Lane
Arlington, OR 97812
(541) 454-2643
(541) 454-3279 Fax

PORT OF TACOMA
WAD001882984
3400 TAYLOR WAY
TACOMA WA 98421

CERTIFICATE OF DISPOSAL

Chemical Waste Management of the Northwest, Inc., ORD089452353, has received the following waste material:

GENERATOR:	PORT OF TACOMA
MANIFEST #:	011880883JJK
CWM TRACKING ID:	42822601
PROFILE #:	OR321468
LINE ITEM:	9b.1
QUANTITY:	1 DT
RECEIVED DATE:	09/17/13
DISPOSAL PROCESS(ES):	LANDFILL
FINAL DISPOSAL LOCATION:	LANDFILL 13
DISPOSAL DATE:	09/17/13

I certify, on behalf of the above listed treatment facility, that to the best of my knowledge, the above-described waste material was managed in compliance with all applicable laws, regulations, permits and licenses on the date listed above.



CWMNW RECORDS DEPARTMENT

Date: 09/19/13



CHEMICAL WASTE MANAGEMENT OF THE NW
 17629 Cedar Springs Lane
 Arlington, OR 97812
 (541) 454-2643
 (541) 454-3279 Fax

PORT OF TACOMA
 WAD001882984
 3400 TAYLOR WAY
 TACOMA WA 98421

CERTIFICATE OF DISPOSAL

Chemical Waste Management of the Northwest, Inc., ORD089452353, has received the following waste material:

GENERATOR:	PORT OF TACOMA	
MANIFEST #:	011880889JJK	
CWM TRACKING ID:	42822701	
PROFILE #:	OR321468	
LINE ITEM:	9b.1	
QUANTITY:	1 DT	
RECEIVED DATE:	09/17/13	
DISPOSAL PROCESS(ES):	LANDFILL	
FINAL DISPOSAL LOCATION:	LANDFILL	13
DISPOSAL DATE:	09/17/13	

I certify, on behalf of the above listed treatment facility, that to the best of my knowledge, the above-described waste material was managed in compliance with all applicable laws, regulations, permits and licenses on the date listed above.

Robbi Jo Galvin

CWMNW RECORDS DEPARTMENT
 Date: 09/19/13



CHEMICAL WASTE MANAGEMENT OF THE NW

17629 Cedar Springs Lane
Arlington, OR 97812
(541) 454-2643
(541) 454-3279 Fax

PORT OF TACOMA
WAD001882984
3400 TAYLOR WAY
TACOMA WA 98421

CERTIFICATE OF DISPOSAL

Chemical Waste Management of the Northwest, Inc., ORD089452353, has received the following waste material:

GENERATOR:	PORT OF TACOMA
MANIFEST #:	011880886JJK
CWM TRACKING ID:	42822801
PROFILE #:	OR321468
LINE ITEM:	9b.1
QUANTITY:	1 DT
RECEIVED DATE:	09/17/13
DISPOSAL PROCESS(ES):	LANDFILL
FINAL DISPOSAL LOCATION:	LANDFILL 13
DISPOSAL DATE:	09/17/13

I certify, on behalf of the above listed treatment facility, that to the best of my knowledge, the above-described waste material was managed in compliance with all applicable laws, regulations, permits and licenses on the date listed above.

CWMNW RECORDS DEPARTMENT

Date: 09/19/13



CHEMICAL WASTE MANAGEMENT OF THE NW

17629 Cedar Springs Lane
Arlington, OR 97812
(541) 454-2643
(541) 454-3279 Fax

PORT OF TACOMA
WAD001882984
3400 TAYLOR WAY
TACOMA WA 98421

CERTIFICATE OF DISPOSAL

Chemical Waste Management of the Northwest, Inc., ORD089452353, has received the following waste material:

GENERATOR:	PORT OF TACOMA
MANIFEST #:	011880887JJK
CWM TRACKING ID:	42822901
PROFILE #:	OR321468
LINE ITEM:	9b.1
QUANTITY:	1 DT
RECEIVED DATE:	09/17/13
DISPOSAL PROCESS(ES):	LANDFILL
FINAL DISPOSAL LOCATION:	LANDFILL 13
DISPOSAL DATE:	09/17/13

I certify, on behalf of the above listed treatment facility, that to the best of my knowledge, the above-described waste material was managed in compliance with all applicable laws, regulations, permits and licenses on the date listed above.

Bobbi Jo Galvin

CWMNW RECORDS DEPARTMENT

Date: 09/19/13



CHEMICAL WASTE MANAGEMENT OF THE NW

17629 Cedar Springs Lane
Arlington, OR 97812
(541) 454-2643
(541) 454-3279 Fax

PORT OF TACOMA
WAD001882984
3400 TAYLOR WAY
TACOMA WA 98421

CERTIFICATE OF DISPOSAL

Chemical Waste Management of the Northwest, Inc., ORD089452353, has received the following waste material:

GENERATOR:	PORT OF TACOMA
MANIFEST #:	011880891JJK
CWM TRACKING ID:	42823001
PROFILE #:	OR321468
LINE ITEM:	9b.1
QUANTITY:	1 DT
RECEIVED DATE:	09/17/13
DISPOSAL PROCESS(ES):	LANDFILL
FINAL DISPOSAL LOCATION:	LANDFILL 13
DISPOSAL DATE:	09/17/13

I certify, on behalf of the above listed treatment facility, that to the best of my knowledge, the above-described waste material was managed in compliance with all applicable laws, regulations, permits and licenses on the date listed above.

Robbie Baldwin

CWMNW RECORDS DEPARTMENT

Date: 09/19/13



CHEMICAL WASTE MANAGEMENT OF THE NW

17629 Cedar Springs Lane
Arlington, OR 97812
(541) 454-2643
(541) 454-3279 Fax

PORT OF TACOMA
WAD001882984
3400 TAYLOR WAY
TACOMA WA 98421

CERTIFICATE OF DISPOSAL

Chemical Waste Management of the Northwest, Inc., ORD089452353, has received the following waste material:

GENERATOR:	PORT OF TACOMA
MANIFEST #:	011880875JJK
CWM TRACKING ID:	42824101
PROFILE #:	OR321468
LINE ITEM:	9b.1
QUANTITY:	1 DT
RECEIVED DATE:	09/18/13
DISPOSAL PROCESS(ES):	LANDFILL
FINAL DISPOSAL LOCATION:	LANDFILL 13
DISPOSAL DATE:	09/18/13

I certify, on behalf of the above listed treatment facility, that to the best of my knowledge, the above-described waste material was managed in compliance with all applicable laws, regulations, permits and licenses on the date listed above.

Bobbi Jo Gehrin

CWMNW RECORDS DEPARTMENT

Date: 09/23/13



CHEMICAL WASTE MANAGEMENT OF THE NW

17629 Cedar Springs Lane
Arlington, OR 97812
(541) 454-2643
(541) 454-3279 Fax

PORT OF TACOMA
WAD001882984
3400 TAYLOR WAY
TACOMA WA 98421

CERTIFICATE OF DISPOSAL

Chemical Waste Management of the Northwest, Inc., ORD089452353, has received the following waste material:

GENERATOR:	PORT OF TACOMA
MANIFEST #:	011880876JJK
CWM TRACKING ID:	42875301
PROFILE #:	OR321468
LINE ITEM:	9b.1
QUANTITY:	1 DT
RECEIVED DATE:	09/18/13
DISPOSAL PROCESS(ES):	LANDFILL
FINAL DISPOSAL LOCATION:	LANDFILL 13
DISPOSAL DATE:	09/18/13

I certify, on behalf of the above listed treatment facility, that to the best of my knowledge, the above-described waste material was managed in compliance with all applicable laws, regulations, permits and licenses on the date listed above.

Bobbi Jo Galum

CWMNW RECORDS DEPARTMENT

Date: 09/23/13



CHEMICAL WASTE MANAGEMENT OF THE NW

17629 Cedar Springs Lane
Arlington, OR 97812
(541) 454-2643
(541) 454-3279 Fax

PORT OF TACOMA
WAD001882984
3400 TAYLOR WAY
TACOMA WA 98421

CERTIFICATE OF DISPOSAL

Chemical Waste Management of the Northwest, Inc., ORD089452353, has received the following waste material:

GENERATOR: PORT OF TACOMA
MANIFEST #: 011880869JJK
CWM TRACKING ID: 42825801
PROFILE #: OR321468
LINE ITEM: 9b.1[†]
QUANTITY: 1 DT
RECEIVED DATE: 09/18/13

DISPOSAL PROCESS(ES): LANDFILL
FINAL DISPOSAL LOCATION: LANDFILL 13
DISPOSAL DATE: 09/18/13

I certify, on behalf of the above listed treatment facility, that to the best of my knowledge, the above-described waste material was managed in compliance with all applicable laws, regulations, permits and licenses on the date listed above.

Bobbi Jo Galvin

CWMNW RECORDS DEPARTMENT

Date: 09/23/13



CHEMICAL WASTE MANAGEMENT OF THE NW

17629 Cedar Springs Lane
Arlington, OR 97812
(541) 454-2643
(541) 454-3279 Fax

PORT OF TACOMA
WAD001882984
3400 TAYLOR WAY
TACOMA WA 98421

CERTIFICATE OF DISPOSAL

Chemical Waste Management of the Northwest, Inc., ORD089452353, has received the following waste material:

GENERATOR: PORT OF TACOMA
MANIFEST #: 011880867JJK
CWM TRACKING ID: 42825901
PROFILE #: OR321468
LINE ITEM: 9b.1
QUANTITY: 1 DT
RECEIVED DATE: 09/18/13

DISPOSAL PROCESS(ES): LANDFILL
FINAL DISPOSAL LOCATION: LANDFILL 13
DISPOSAL DATE: 09/18/13

I certify, on behalf of the above listed treatment facility, that to the best of my knowledge, the above-described waste material was managed in compliance with all applicable laws, regulations, permits and licenses on the date listed above.

Robbino Galvin

CWMNW RECORDS DEPARTMENT

Date: 09/23/13



CHEMICAL WASTE MANAGEMENT OF THE NW
17629 Cedar Springs Lane
Arlington, OR 97812
(541) 454-2643
(541) 454-3279 Fax

PORT OF TACOMA
WAD001882984
3400 TAYLOR WAY
TACOMA WA 98421

CERTIFICATE OF DISPOSAL

Chemical Waste Management of the Northwest, Inc., ORD089452353, has received the following waste material:

GENERATOR:	PORT OF TACOMA
MANIFEST #:	011880870JJK
CWM TRACKING ID:	42826001
PROFILE #:	OR321468
LINE ITEM:	9b.1
QUANTITY:	1 DT
RECEIVED DATE:	09/18/13
DISPOSAL PROCESS(ES):	LANDFILL
FINAL DISPOSAL LOCATION:	LANDFILL 13
DISPOSAL DATE:	09/18/13

I certify, on behalf of the above listed treatment facility, that to the best of my knowledge, the above-described waste material was managed in compliance with all applicable laws, regulations, permits and licenses on the date listed above.

Robbino Galvin

CWMNW RECORDS DEPARTMENT

Date: 09/23/13



CHEMICAL WASTE MANAGEMENT OF THE NW
17629 Cedar Springs Lane
Arlington, OR 97812
(541) 454-2643
(541) 454-3279 Fax

PORT OF TACOMA
WAD001882984
3400 TAYLOR WAY
TACOMA WA 98421

CERTIFICATE OF DISPOSAL

Chemical Waste Management of the Northwest, Inc., ORD089452353, has received the following waste material:

GENERATOR:	PORT OF TACOMA
MANIFEST #:	011880866JJK
CWM TRACKING ID:	42826201
PROFILE #:	OR321468
LINE ITEM:	9b.1
QUANTITY:	1 DT
RECEIVED DATE:	09/18/13
DISPOSAL PROCESS(ES):	LANDFILL
FINAL DISPOSAL LOCATION:	LANDFILL 13
DISPOSAL DATE:	09/18/13

I certify, on behalf of the above listed treatment facility, that to the best of my knowledge, the above-described waste material was managed in compliance with all applicable laws, regulations, permits and licenses on the date listed above.

Bobbi Jo Galvin

CWMNW RECORDS DEPARTMENT

Date: 09/23/13



CHEMICAL WASTE MANAGEMENT OF THE NW
17629 Cedar Springs Lane
Arlington, OR 97812
(541) 454-2643
(541) 454-3279 Fax

PORT OF TACOMA
WAD001882984
3400 TAYLOR WAY
TACOMA WA 98421

CERTIFICATE OF DISPOSAL

Chemical Waste Management of the Northwest, Inc., ORD089452353, has received the following waste material:

GENERATOR:	PORT OF TACOMA
MANIFEST #:	011880865JJK
CWM TRACKING ID:	42826501
PROFILE #:	OR321468
LINE ITEM:	9b.1
QUANTITY:	1 DT
RECEIVED DATE:	09/18/13
DISPOSAL PROCESS(ES):	LANDFILL
FINAL DISPOSAL LOCATION:	LANDFILL 13
DISPOSAL DATE:	09/18/13

I certify, on behalf of the above listed treatment facility, that to the best of my knowledge, the above-described waste material was managed in compliance with all applicable laws, regulations, permits and licenses on the date listed above.

Bobbi Jo Galvin

CWMNW RECORDS DEPARTMENT

Date: 09/23/13



CHEMICAL WASTE MANAGEMENT OF THE NW

17629 Cedar Springs Lane
Arlington, OR 97812
(541) 454-2643
(541) 454-3279 Fax

PORT OF TACOMA
WAD001882984
3400 TAYLOR WAY
TACOMA WA 98421

CERTIFICATE OF DISPOSAL

Chemical Waste Management of the Northwest, Inc., ORD089452353, has received the following waste material:

GENERATOR:	PORT OF TACOMA
MANIFEST #:	011880864JJK
CWM TRACKING ID:	42826701
PROFILE #:	OR321468
LINE ITEM:	9b.1
QUANTITY:	1 DT
RECEIVED DATE:	09/18/13
DISPOSAL PROCESS(ES):	LANDFILL
FINAL DISPOSAL LOCATION:	LANDFILL 13
DISPOSAL DATE:	09/18/13

I certify, on behalf of the above listed treatment facility, that to the best of my knowledge, the above-described waste material was managed in compliance with all applicable laws, regulations, permits and licenses on the date listed above.

Bobbi Jo Galvin

CWMNW RECORDS DEPARTMENT

Date: 09/23/13



CHEMICAL WASTE MANAGEMENT OF THE NW
17629 Cedar Springs Lane
Arlington, OR 97812
(541) 454-2643
(541) 454-3279 Fax

PORT OF TACOMA
WAD001882984
3400 TAYLOR WAY
TACOMA WA 98421

CERTIFICATE OF DISPOSAL

Chemical Waste Management of the Northwest, Inc., ORD089452353, has received the following waste material:

GENERATOR:	PORT OF TACOMA
MANIFEST #:	011880872JJK
CWM TRACKING ID:	42826901
PROFILE #:	OR321468
LINE ITEM:	9b.1
QUANTITY:	1 D ⁺
RECEIVED DATE:	09/18/13
DISPOSAL PROCESS(ES):	LANDFILL
FINAL DISPOSAL LOCATION:	LANDFILL 13
DISPOSAL DATE:	09/18/13

I certify, on behalf of the above listed treatment facility, that to the best of my knowledge, the above-described waste material was managed in compliance with all applicable laws, regulations, permits and licenses on the date listed above.

Bobbi Jobalvin

CWMNW RECORDS DEPARTMENT

Date: 09/23/13



CHEMICAL WASTE MANAGEMENT OF THE NW
17629 Cedar Springs Lane
Arlington, OR 97812
(541) 454-2643
(541) 454-3279 Fax

PORT OF TACOMA
WAD001882984
3400 TAYLOR WAY
TACOMA WA 98421

CERTIFICATE OF DISPOSAL

Chemical Waste Management of the Northwest, Inc., ORD089452353, has received the following waste material:

GENERATOR:	PORT OF TACOMA
MANIFEST #:	011880871JJK
CWM TRACKING ID:	42827101
PROFILE #:	OR321468
LINE ITEM:	9b.1
QUANTITY:	1 DT
RECEIVED DATE:	09/18/13
DISPOSAL PROCESS(ES):	LANDFILL
FINAL DISPOSAL LOCATION:	LANDFILL 13
DISPOSAL DATE:	09/18/13

I certify, on behalf of the above listed treatment facility, that to the best of my knowledge, the above-described waste material was managed in compliance with all applicable laws, regulations, permits and licenses on the date listed above.

Bobbi Jo Galun

CWMNW RECORDS DEPARTMENT
Date: 09/23/13



CHEMICAL WASTE MANAGEMENT OF THE NW

17629 Cedar Springs Lane
Arlington, OR 97812
(541) 454-2643
(541) 454-3279 Fax

PORT OF TACOMA
WAD001882984
3400 TAYLOR WAY
TACOMA WA 98421

CERTIFICATE OF DISPOSAL

Chemical Waste Management of the Northwest, Inc., ORD089452353, has received the following waste material:

GENERATOR:	PORT OF TACOMA
MANIFEST #:	011880861JJK
CWM TRACKING ID:	42827201
PROFILE #:	OR321468
LINE ITEM:	9b.1
QUANTITY:	1 DT
RECEIVED DATE:	09/18/13
DISPOSAL PROCESS(ES):	LANDFILL
FINAL DISPOSAL LOCATION:	LANDFILL 13
DISPOSAL DATE:	09/18/13

I certify, on behalf of the above listed treatment facility, that to the best of my knowledge, the above-described waste material was managed in compliance with all applicable laws, regulations, permits and licenses on the date listed above.

Bobbi Jo Galvin

CWMNW RECORDS DEPARTMENT

Date: 09/23/13



CHEMICAL WASTE MANAGEMENT OF THE NW
17629 Cedar Springs Lane
Arlington, OR 97812
(541) 454-2643
(541) 454-3279 Fax

PORT OF TACOMA
WAD001882984
3400 TAYLOR WAY
TACOMA WA 98421

CERTIFICATE OF DISPOSAL

Chemical Waste Management of the Northwest, Inc., ORD089452353, has received the following waste material:

GENERATOR:	PORT OF TACOMA
MANIFEST #:	011880873JJK
CWM TRACKING ID:	42827401
PROFILE #:	OR321468
LINE ITEM:	9b.1
QUANTITY:	1 DT
RECEIVED DATE:	09/18/13
DISPOSAL PROCESS(ES):	LANDFILL
FINAL DISPOSAL LOCATION:	LANDFILL 13
DISPOSAL DATE:	09/18/13

I certify, on behalf of the above listed treatment facility, that to the best of my knowledge, the above-described waste material was managed in compliance with all applicable laws, regulations, permits and licenses on the date listed above.



CWMNW RECORDS DEPARTMENT

Date: 09/23/13



CHEMICAL WASTE MANAGEMENT OF THE NW

17629 Cedar Springs Lane
Arlington, OR 97812
(541) 454-2643
(541) 454-3279 Fax

PORT OF TACOMA
WAD001882984
3400 TAYLOR WAY
TACOMA WA 98421

CERTIFICATE OF DISPOSAL

Chemical Waste Management of the Northwest, Inc., ORD089452353, has received the following waste material:

GENERATOR:	PORT OF TACOMA
MANIFEST #:	011880862JJK
CWM TRACKING ID:	42827501
PROFILE #:	OR321468
LINE ITEM:	9b.1
QUANTITY:	1 DT
RECEIVED DATE:	09/18/13
DISPOSAL PROCESS(ES):	LANDFILL
FINAL DISPOSAL LOCATION:	LANDFILL 13
DISPOSAL DATE:	09/18/13

I certify, on behalf of the above listed treatment facility, that to the best of my knowledge, the above-described waste material was managed in compliance with all applicable laws, regulations, permits and licenses on the date listed above.

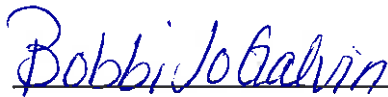

CWMNW RECORDS DEPARTMENT

Date: 09/23/13



CHEMICAL WASTE MANAGEMENT OF THE NW

17629 Cedar Springs Lane
Arlington, OR 97812
(541) 454-2643
(541) 454-3279 Fax

PORT OF TACOMA
WAD001882984
3400 TAYLOR WAY
TACOMA WA 98421

CERTIFICATE OF DISPOSAL

Chemical Waste Management of the Northwest, Inc., ORD089452353, has received the following waste material:

GENERATOR:	PORT OF TACOMA
MANIFEST #:	011880863JJK
CWM TRACKING ID:	42827601
PROFILE #:	OR321468
LINE ITEM:	9b.1
QUANTITY:	1 DT
RECEIVED DATE:	09/18/13
DISPOSAL PROCESS(ES):	LANDFILL
FINAL DISPOSAL LOCATION:	LANDFILL 13
DISPOSAL DATE:	09/18/13

I certify, on behalf of the above listed treatment facility, that to the best of my knowledge, the above-described waste material was managed in compliance with all applicable laws, regulations, permits and licenses on the date listed above.



CWMNW RECORDS DEPARTMENT

Date: 09/23/13



CHEMICAL WASTE MANAGEMENT OF THE NW
17629 Cedar Springs Lane
Arlington, OR 97812
(541) 454-2643
(541) 454-3279 Fax

PORT OF TACOMA
WAD001882984
3400 TAYLOR WAY
TACOMA WA 98421

CERTIFICATE OF DISPOSAL

Chemical Waste Management of the Northwest, Inc., ORD089452353, has received the following waste material:

GENERATOR:	PORT OF TACOMA
MANIFEST #:	011880860JJK
CWM TRACKING ID:	42827801
PROFILE #:	OR321468
LINE ITEM:	9b.1
QUANTITY:	1 DT
RECEIVED DATE:	09/18/13
DISPOSAL PROCESS(ES):	LANDFILL
FINAL DISPOSAL LOCATION:	LANDFILL 13
DISPOSAL DATE:	09/18/13

I certify, on behalf of the above listed treatment facility, that to the best of my knowledge, the above-described waste material was managed in compliance with all applicable laws, regulations, permits and licenses on the date listed above.

Bobbi Galvin

CWMNW RECORDS DEPARTMENT

Date: 09/23/13



CHEMICAL WASTE MANAGEMENT OF THE NW

17629 Cedar Springs Lane
Arlington, OR 97812
(541) 454-2643
(541) 454-3279 Fax

PORT OF TACOMA
WAD001882984
3400 TAYLOR WAY
TACOMA WA 98421

CERTIFICATE OF DISPOSAL

Chemical Waste Management of the Northwest, Inc., ORD089452353, has received the following waste material:

GENERATOR:	PORT OF TACOMA
MANIFEST #:	011880859JJK
CWM TRACKING ID:	42828201
PROFILE #:	OR321468
LINE ITEM:	9b.1
QUANTITY:	1 DT
RECEIVED DATE:	09/18/13
DISPOSAL PROCESS(ES):	LANDFILL
FINAL DISPOSAL LOCATION:	LANDFILL 13
DISPOSAL DATE:	09/18/13

I certify, on behalf of the above listed treatment facility, that to the best of my knowledge, the above-described waste material was managed in compliance with all applicable laws, regulations, permits and licenses on the date listed above.

Robbino Galvin

CWMNW RECORDS DEPARTMENT

Date: 09/23/13



CHEMICAL WASTE MANAGEMENT OF THE NW

17629 Cedar Springs Lane
Arlington, OR 97812
(541) 454-2643
(541) 454-3279 Fax

PORT OF TACOMA
WAD001882984
3400 TAYLOR WAY
TACOMA WA 98421

CERTIFICATE OF DISPOSAL

Chemical Waste Management of the Northwest, Inc., ORD089452353, has received the following waste material:

GENERATOR:	PORT OF TACOMA
MANIFEST #:	011880874JJK
CWM TRACKING ID:	42828001
PROFILE #:	OR321468
LINE ITEM:	9b.1
QUANTITY:	1 DT
RECEIVED DATE:	09/18/13
DISPOSAL PROCESS(ES):	LANDFILL
FINAL DISPOSAL LOCATION:	LANDFILL 13
DISPOSAL DATE:	09/18/13

I certify, on behalf of the above listed treatment facility, that to the best of my knowledge, the above-described waste material was managed in compliance with all applicable laws, regulations, permits and licenses on the date listed above.

CWMNW RECORDS DEPARTMENT

Date: 09/24/13



CHEMICAL WASTE MANAGEMENT OF THE NW

17629 Cedar Springs Lane
Arlington, OR 97812
(541) 454-2643
(541) 454-3279 Fax

PORT OF TACOMA
WAD001882984
3400 TAYLOR WAY
TACOMA WA 98421

CERTIFICATE OF DISPOSAL

Chemical Waste Management of the Northwest, Inc., ORD089452353, has received the following waste material:

GENERATOR:	PORT OF TACOMA
MANIFEST #:	011880853JJK
CWM TRACKING ID:	42811901
PROFILE #:	OR321468
LINE ITEM:	9b.1
QUANTITY:	1 DT
RECEIVED DATE:	09/19/13
DISPOSAL PROCESS(ES):	LANDFILL
FINAL DISPOSAL LOCATION:	LANDFILL 13
DISPOSAL DATE:	09/19/13

I certify, on behalf of the above listed treatment facility, that to the best of my knowledge, the above-described waste material was managed in compliance with all applicable laws, regulations, permits and licenses on the date listed above.



CWMNW RECORDS DEPARTMENT

Date: 09/24/13



CHEMICAL WASTE MANAGEMENT OF THE NW

17629 Cedar Springs Lane
Arlington, OR 97812
(541) 454-2643
(541) 454-3279 Fax

PORT OF TACOMA
WAD001882984
3400 TAYLOR WAY
TACOMA WA 98421

CERTIFICATE OF DISPOSAL

Chemical Waste Management of the Northwest, Inc., ORD089452353, has received the following waste material:

GENERATOR: PORT OF TACOMA
MANIFEST #: 011880851JJK
CWM TRACKING ID: 42831801
PROFILE #: OR321468
LINE ITEM: 9b.1
QUANTITY: 1 DT
RECEIVED DATE: 09/19/13

DISPOSAL PROCESS(ES): LANDFILL
FINAL DISPOSAL LOCATION: LANDFILL 13
DISPOSAL DATE: 09/19/13

I certify, on behalf of the above listed treatment facility, that to the best of my knowledge, the above-described waste material was managed in compliance with all applicable laws, regulations, permits and licenses on the date listed above.

Bobbi Jo Galvin

CWMNW RECORDS DEPARTMENT

Date: 09/24/13



CHEMICAL WASTE MANAGEMENT OF THE NW

17629 Cedar Springs Lane
Arlington, OR 97812
(541) 454-2643
(541) 454-3279 Fax

PORT OF TACOMA
WAD001882984
3400 TAYLOR WAY
TACOMA WA 98421

CERTIFICATE OF DISPOSAL

Chemical Waste Management of the Northwest, Inc., ORD089452353, has received the following waste material:

GENERATOR: PORT OF TACOMA
MANIFEST #: 011880854JJK
CWM TRACKING ID: 42829901
PROFILE #: OR321468
LINE ITEM: 9b.1
QUANTITY: 1 DT
RECEIVED DATE: 09/19/13

DISPOSAL PROCESS(ES): LANDFILL
FINAL DISPOSAL LOCATION: LANDFILL 13
DISPOSAL DATE: 09/19/13

I certify, on behalf of the above listed treatment facility, that to the best of my knowledge, the above-described waste material was managed in compliance with all applicable laws, regulations, permits and licenses on the date listed above.



CWMNW RECORDS DEPARTMENT

Date: 09/24/13



CHEMICAL WASTE MANAGEMENT OF THE NW

17629 Cedar Springs Lane
Arlington, OR 97812
(541) 454-2643
(541) 454-3279 Fax

PORT OF TACOMA
WAD001882984
3400 TAYLOR WAY
TACOMA WA 98421

CERTIFICATE OF DISPOSAL

Chemical Waste Management of the Northwest, Inc., ORD089452353, has received the following waste material:

GENERATOR:	PORT OF TACOMA
MANIFEST #:	011880858JJK
CWM TRACKING ID:	42834001
PROFILE #:	OR321468
LINE ITEM:	9b.1
QUANTITY:	1 DT
RECEIVED DATE:	09/19/13
DISPOSAL PROCESS(ES):	LANDFILL
FINAL DISPOSAL LOCATION:	LANDFILL 13
DISPOSAL DATE:	09/19/13

I certify, on behalf of the above listed treatment facility, that to the best of my knowledge, the above-described waste material was managed in compliance with all applicable laws, regulations, permits and licenses on the date listed above.

CWMNW RECORDS DEPARTMENT

Date: 09/24/13



CHEMICAL WASTE MANAGEMENT OF THE NW

17629 Cedar Springs Lane
Arlington, OR 97812
(541) 454-2643
(541) 454-3279 Fax

PORT OF TACOMA
WAD001882984
3400 TAYLOR WAY
TACOMA WA 98421

CERTIFICATE OF DISPOSAL

Chemical Waste Management of the Northwest, Inc., ORD089452353, has received the following waste material:

GENERATOR:	PORT OF TACOMA
MANIFEST #:	011880855JJK
CWM TRACKING ID:	42833601
PROFILE #:	OR321468
LINE ITEM:	9b.1
QUANTITY:	1 DT
RECEIVED DATE:	09/19/13
DISPOSAL PROCESS(ES):	LANDFILL
FINAL DISPOSAL LOCATION:	LANDFILL 13
DISPOSAL DATE:	09/19/13

I certify, on behalf of the above listed treatment facility, that to the best of my knowledge, the above-described waste material was managed in compliance with all applicable laws, regulations, permits and licenses on the date listed above.

Bobbi Jobalin

CWMNW RECORDS DEPARTMENT

Date: 09/24/13



CHEMICAL WASTE MANAGEMENT OF THE NW

17629 Cedar Springs Lane
Arlington, OR 97812
(541) 454-2643
(541) 454-3279 Fax

PORT OF TACOMA
WAD001882984
3400 TAYLOR WAY
TACOMA WA 98421

CERTIFICATE OF DISPOSAL

Chemical Waste Management of the Northwest, Inc., ORD089452353, has received the following waste material:

GENERATOR:	PORT OF TACOMA
MANIFEST #:	011880857JJK
CWM TRACKING ID:	42833101
PROFILE #:	OR321468
LINE ITEM:	9b.1
QUANTITY:	1 DT
RECEIVED DATE:	09/19/13
DISPOSAL PROCESS(ES):	LANDFILL
FINAL DISPOSAL LOCATION:	LANDFILL 13
DISPOSAL DATE:	09/19/13

I certify, on behalf of the above listed treatment facility, that to the best of my knowledge, the above-described waste material was managed in compliance with all applicable laws, regulations, permits and licenses on the date listed above.

Robbi Jo Franklin

CWMNW RECORDS DEPARTMENT

Date: 09/24/13



CHEMICAL WASTE MANAGEMENT OF THE NW
17629 Cedar Springs Lane
Arlington, OR 97812
(541) 454-2643
(541) 454-3279 Fax

PORT OF TACOMA
WAD001882984
3400 TAYLOR WAY
TACOMA WA 98421

CERTIFICATE OF DISPOSAL

Chemical Waste Management of the Northwest, Inc., ORD089452353, has received the following waste material:

GENERATOR:	PORT OF TACOMA
MANIFEST #:	011880848JJK
CWM TRACKING ID:	42833001
PROFILE #:	OR321468
LINE ITEM:	9b.1
QUANTITY:	1 DT
RECEIVED DATE:	09/19/13
DISPOSAL PROCESS(ES):	LANDFILL
FINAL DISPOSAL LOCATION:	LANDFILL 13
DISPOSAL DATE:	09/19/13

I certify, on behalf of the above listed treatment facility, that to the best of my knowledge, the above-described waste material was managed in compliance with all applicable laws, regulations, permits and licenses on the date listed above.

Bobbi Jo Galvin

CWMNW RECORDS DEPARTMENT

Date: 09/24/13



CHEMICAL WASTE MANAGEMENT OF THE NW

17629 Cedar Springs Lane
Arlington, OR 97812
(541) 454-2643
(541) 454-3279 Fax

PORT OF TACOMA
WAD001882984
3400 TAYLOR WAY
TACOMA WA 98421

CERTIFICATE OF DISPOSAL

Chemical Waste Management of the Northwest, Inc., ORD089452353, has received the following waste material:

GENERATOR:	PORT OF TACOMA
MANIFEST #:	011880850JJK
CWM TRACKING ID:	42832801
PROFILE #:	OR321468
LINE ITEM:	9b.1
QUANTITY:	1 DT
RECEIVED DATE:	09/19/13
DISPOSAL PROCESS(ES):	LANDFILL
FINAL DISPOSAL LOCATION:	LANDFILL 13
DISPOSAL DATE:	09/19/13

I certify, on behalf of the above listed treatment facility, that to the best of my knowledge, the above-described waste material was managed in compliance with all applicable laws, regulations, permits and licenses on the date listed above.

CWMNW RECORDS DEPARTMENT

Date: 09/24/13



CHEMICAL WASTE MANAGEMENT OF THE NW

17629 Cedar Springs Lane
Arlington, OR 97812
(541) 454-2643
(541) 454-3279 Fax

PORT OF TACOMA
WAD001882984
3400 TAYLOR WAY
TACOMA WA 98421

CERTIFICATE OF DISPOSAL

Chemical Waste Management of the Northwest, Inc., ORD089452353, has received the following waste material:

GENERATOR:	PORT OF TACOMA
MANIFEST #:	011880856JJK
CWM TRACKING ID:	42832701
PROFILE #:	OR321468
LINE ITEM:	9b.1
QUANTITY:	1 DT
RECEIVED DATE:	09/19/13
DISPOSAL PROCESS(ES):	LANDFILL
FINAL DISPOSAL LOCATION:	LANDFILL 13
DISPOSAL DATE:	09/19/13

I certify, on behalf of the above listed treatment facility, that to the best of my knowledge, the above-described waste material was managed in compliance with all applicable laws, regulations, permits and licenses on the date listed above.

Bobbi Halvin

CWMNW RECORDS DEPARTMENT

Date: 09/24/13



CHEMICAL WASTE MANAGEMENT OF THE NW
17629 Cedar Springs Lane
Arlington, OR 97812
(541) 454-2643
(541) 454-3279 Fax

PORT OF TACOMA
WAD001882984
3400 TAYLOR WAY
TACOMA WA 98421

CERTIFICATE OF DISPOSAL

Chemical Waste Management of the Northwest, Inc., ORD089452353, has received the following waste material:

GENERATOR:	PORT OF TACOMA
MANIFEST #:	011880847JJK
CWM TRACKING ID:	42832601
PROFILE #:	OR321468
LINE ITEM:	9b.1
QUANTITY:	1 DT
RECEIVED DATE:	09/19/13
DISPOSAL PROCESS(ES):	LANDFILL
FINAL DISPOSAL LOCATION:	LANDFILL 13
DISPOSAL DATE:	09/19/13

I certify, on behalf of the above listed treatment facility, that to the best of my knowledge, the above-described waste material was managed in compliance with all applicable laws, regulations, permits and licenses on the date listed above.

Bobbi Jo Galvin

CWMNW RECORDS DEPARTMENT

Date: 09/24/13



CHEMICAL WASTE MANAGEMENT OF THE NW
17629 Cedar Springs Lane
Arlington, OR 97812
(541) 454-2643
(541) 454-3279 Fax

PORT OF TACOMA
WAD001882984
3400 TAYLOR WAY
TACOMA WA 98421

CERTIFICATE OF DISPOSAL

Chemical Waste Management of the Northwest, Inc., ORD089452353, has received the following waste material:

GENERATOR:	PORT OF TACOMA
MANIFEST #:	011880852JJK
CWM TRACKING ID:	42832501
PROFILE #:	OR321468
LINE ITEM:	9b.1
QUANTITY:	1 DT
RECEIVED DATE:	09/19/13
DISPOSAL PROCESS(ES):	LANDFILL
FINAL DISPOSAL LOCATION:	LANDFILL 13
DISPOSAL DATE:	09/19/13

I certify, on behalf of the above listed treatment facility, that to the best of my knowledge, the above-described waste material was managed in compliance with all applicable laws, regulations, permits and licenses on the date listed above.

Bobbi Johnson

CWMNW RECORDS DEPARTMENT

Date: 09/24/13



CHEMICAL WASTE MANAGEMENT OF THE NW

17629 Cedar Springs Lane
Arlington, OR 97812
(541) 454-2643
(541) 454-3279 Fax

PORT OF TACOMA
WAD001882984
3400 TAYLOR WAY
TACOMA WA 98421

CERTIFICATE OF DISPOSAL

Chemical Waste Management of the Northwest, Inc., ORD089452353, has received the following waste material:

GENERATOR:	PORT OF TACOMA
MANIFEST #:	011880849JJK
CWM TRACKING ID:	42832401
PROFILE #:	OR321468
LINE ITEM:	9b.1
QUANTITY:	1 DT
RECEIVED DATE:	09/19/13
DISPOSAL PROCESS(ES):	LANDFILL
FINAL DISPOSAL LOCATION:	LANDFILL 13
DISPOSAL DATE:	09/19/13

I certify, on behalf of the above listed treatment facility, that to the best of my knowledge, the above-described waste material was managed in compliance with all applicable laws, regulations, permits and licenses on the date listed above.

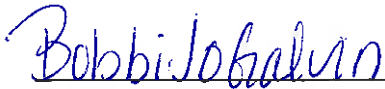

CWMNW RECORDS DEPARTMENT

Date: 09/24/13



CHEMICAL WASTE MANAGEMENT OF THE NW
17629 Cedar Springs Lane
Arlington, OR 97812
541 454 2643

PORT OF TACOMA
WAD001882984
3400 TAYLOR WAY
TACOMA WA 98421

CERTIFICATE OF DISPOSAL

Chemical Waste Management of the Northwest, Inc., ORD089452353, has received the following waste material:

GENERATOR: PORT OF TACOMA
MANIFEST #: 011880846JJK
CWM TRACKING ID: 42837301
PROFILE #: OR321468
LINE ITEM: 9b.1
QUANTITY: 1 DT
RECEIVED DATE: 09/20/13

DISPOSAL PROCESS(ES): LANDFILL
FINAL DISPOSAL LOCATION: LANDFILL 13
DISPOSAL DATE: 09/20/13

I certify, on behalf of the above listed treatment facility, that to the best of my knowledge, the above-described waste material was managed in compliance with all applicable laws, regulations, permits and licenses on the date listed above.

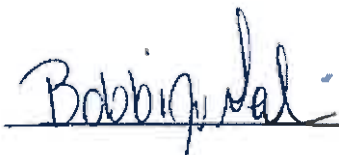

CWMNW RECORDS DEPARTMENT

Date: 09/21/13



CHEMICAL WASTE MANAGEMENT OF THE NW
17629 Cedar Springs Lane
Arlington, OR 97812
(541) 454-2643
(541) 454-3279 Fax

PORT OF TACOMA
WAD001882984
3400 TAYLOR WAY
TACOMA WA 98421

CERTIFICATE OF DISPOSAL

Chemical Waste Management of the Northwest, Inc., ORD089452353, has received the following waste material:

GENERATOR:	PORT OF TACOMA
MANIFEST #:	011880833JJK
CWM TRACKING ID:	42840601
PROFILE #:	OR321468
LINE ITEM:	9b.1
QUANTITY:	1 D7
RECEIVED DATE:	09/20/13
DISPOSAL PROCESS(ES):	LANDFILL
FINAL DISPOSAL LOCATION:	LANDFILL 13
DISPOSAL DATE:	09/20/13

I certify, on behalf of the above listed treatment facility, that to the best of my knowledge, the above-described waste material was managed in compliance with all applicable laws, regulations, permits and licenses on the date listed above.

Bobbi Jo Galvin

CWMNW RECORDS DEPARTMENT
Date: 09/24/13



CHEMICAL WASTE MANAGEMENT OF THE NW
17629 Cedar Springs Lane
Arlington, OR 97812
(541) 454-2643
(541) 454-3279 Fax

PORT OF TACOMA
WAD001882984
3400 TAYLOR WAY
TACOMA WA 98421

CERTIFICATE OF DISPOSAL

Chemical Waste Management of the Northwest, Inc., ORD089452353, has received the following waste material:

GENERATOR:	PORT OF TACOMA
MANIFEST #:	011880832JJK
CWM TRACKING ID:	42840001
PROFILE #:	OR321468
LINE ITEM:	9b.1
QUANTITY:	1 DT
RECEIVED DATE:	09/20/13
DISPOSAL PROCESS(ES):	LANDFILL
FINAL DISPOSAL LOCATION:	LANDFILL 13
DISPOSAL DATE:	09/20/13

I certify, on behalf of the above listed treatment facility, that to the best of my knowledge, the above-described waste material was managed in compliance with all applicable laws, regulations, permits and licenses on the date listed above.



CWMNW RECORDS DEPARTMENT
Date:

09/24/13



CHEMICAL WASTE MANAGEMENT OF THE NW
17629 Cedar Springs Lane
Arlington, OR 97812
(541) 454-2643
(541) 454-3279 Fax

PORT OF TACOMA
WAD001882984
3400 TAYLOR WAY
TACOMA WA 98421

CERTIFICATE OF DISPOSAL

Chemical Waste Management of the Northwest, Inc., ORD089452353, has received the following waste material:

GENERATOR:	PORT OF TACOMA
MANIFEST #:	011880831JJK
CWM TRACKING ID:	42839301
PROFILE #:	OR321468
LINE ITEM:	9b.1
QUANTITY:	1 DT
RECEIVED DATE:	09/20/13
DISPOSAL PROCESS(ES):	LANDFILL
FINAL DISPOSAL LOCATION:	LANDFILL 13
DISPOSAL DATE:	09/20/13

I certify, on behalf of the above listed treatment facility, that to the best of my knowledge, the above-described waste material was managed in compliance with all applicable laws, regulations, permits and licenses on the date listed above.



CWMNW RECORDS DEPARTMENT
Date: 09/24/13



CHEMICAL WASTE MANAGEMENT OF THE NW

17629 Cedar Springs Lane
Arlington, OR 97812
(541) 454-2643
(541) 454-3279 Fax

1

PORT OF TACOMA
WAD001882984
3400 TAYLOR WAY
TACOMA WA 98421

CERTIFICATE OF DISPOSAL

Chemical Waste Management of the Northwest, Inc., ORD089452353, has received the following waste material:

GENERATOR: PORT OF TACOMA
MANIFEST #: 011880840JJK
CWM TRACKING ID: 42839001
PROFILE #: OR321468
LINE ITEM: 9b.1
QUANTITY: 1 DT
RECEIVED DATE: 09/20/13

DISPOSAL PROCESS(ES): LANDFILL
FINAL DISPOSAL LOCATION: LANDFILL 13
DISPOSAL DATE: 09/20/13

I certify, on behalf of the above listed treatment facility, that to the best of my knowledge, the above-described waste material was managed in compliance with all applicable laws, regulations, permits and licenses on the date listed above.

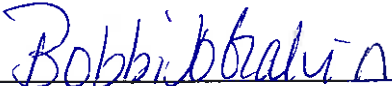

CWMNW RECORDS DEPARTMENT

Date: 09/24/13

1



CHEMICAL WASTE MANAGEMENT OF THE NW

17629 Cedar Springs Lane
Arlington, OR 97812
(541) 454-2643
(541) 454-3279 Fax

PORT OF TACOMA
WAD001882984
3400 TAYLOR WAY
TACOMA WA 98421

CERTIFICATE OF DISPOSAL

Chemical Waste Management of the Northwest, Inc., ORD089452353, has received the following waste material:

GENERATOR:	PORT OF TACOMA
MANIFEST #:	011880841JJK
CWM TRACKING ID:	42838901
PROFILE #:	OR321468
LINE ITEM:	9b.1
QUANTITY:	1 DT
RECEIVED DATE:	09/20/13
DISPOSAL PROCESS(ES):	LANDFILL
FINAL DISPOSAL LOCATION:	LANDFILL 13
DISPOSAL DATE:	09/20/13

I certify, on behalf of the above listed treatment facility, that to the best of my knowledge, the above-described waste material was managed in compliance with all applicable laws, regulations, permits and licenses on the date listed above.



CWMNW RECORDS DEPARTMENT

Date: 09/24/13



CHEMICAL WASTE MANAGEMENT OF THE NW

17629 Cedar Springs Lane
Arlington, OR 97812
(541) 454-2643
(541) 454-3279 Fax

PORT OF TACOMA
WAD001882984
3400 TAYLOR WAY
TACOMA WA 98421

CERTIFICATE OF DISPOSAL

Chemical Waste Management of the Northwest, Inc., ORD089452353, has received the following waste material:

GENERATOR:	PORT OF TACOMA
MANIFEST #:	011880843JJK
CWM TRACKING ID:	42838801
PROFILE #:	OR321468
LINE ITEM:	9b.1
QUANTITY:	1 DT
RECEIVED DATE:	09/20/13
DISPOSAL PROCESS(ES):	LANDFILL
FINAL DISPOSAL LOCATION:	LANDFILL 13
DISPOSAL DATE:	09/20/13

I certify, on behalf of the above listed treatment facility, that to the best of my knowledge, the above-described waste material was managed in compliance with all applicable laws, regulations, permits and licenses on the date listed above.

Bobbi Jobalvin

CWMNW RECORDS DEPARTMENT

Date: 09/24/13



CHEMICAL WASTE MANAGEMENT OF THE NW

17629 Cedar Springs Lane
Arlington, OR 97812
(541) 454-2643
(541) 454-3279 Fax

PORT OF TACOMA
WAD001882984
3400 TAYLOR WAY
TACOMA WA 98421

CERTIFICATE OF DISPOSAL

Chemical Waste Management of the Northwest, Inc., ORD089452353, has received the following waste material:

GENERATOR:	PORT OF TACOMA
MANIFEST #:	011880835JJK
CWM TRACKING ID:	42838701
PROFILE #:	OR321468
LINE ITEM:	9b.1
QUANTITY:	1 DT
RECEIVED DATE:	09/20/13
DISPOSAL PROCESS(ES):	LANDFILL
FINAL DISPOSAL LOCATION:	LANDFILL 13
DISPOSAL DATE:	09/20/13

I certify, on behalf of the above listed treatment facility, that to the best of my knowledge, the above-described waste material was managed in compliance with all applicable laws, regulations, permits and licenses on the date listed above.

Robbie J. Galvin

CWMNW RECORDS DEPARTMENT

Date: 09/24/13



CHEMICAL WASTE MANAGEMENT OF THE NW

17629 Cedar Springs Lane
Arlington, OR 97812
(541) 454-2643
(541) 454-3279 Fax

PORT OF TACOMA
WAD001882984
3400 TAYLOR WAY
TACOMA WA 98421

CERTIFICATE OF DISPOSAL

Chemical Waste Management of the Northwest, Inc., ORD089452353, has received the following waste material:

GENERATOR:	PORT OF TACOMA
MANIFEST #:	011880834JJK
CWM TRACKING ID:	42838601
PROFILE #:	OR321468
LINE ITEM:	9b.1
QUANTITY:	1 DT
RECEIVED DATE:	09/20/13
DISPOSAL PROCESS(ES):	LANDFILL
FINAL DISPOSAL LOCATION:	LANDFILL 13
DISPOSAL DATE:	09/20/13

I certify, on behalf of the above listed treatment facility, that to the best of my knowledge, the above-described waste material was managed in compliance with all applicable laws, regulations, permits and licenses on the date listed above.

Bobbie Galvin

CWMNW RECORDS DEPARTMENT

Date: 09/24/13



CHEMICAL WASTE MANAGEMENT OF THE NW

17629 Cedar Springs Lane
Arlington, OR 97812
(541) 454-2643
(541) 454-3279 Fax

PORT OF TACOMA
WAD001882984
3400 TAYLOR WAY
TACOMA WA 98421

CERTIFICATE OF DISPOSAL

Chemical Waste Management of the Northwest, Inc., ORD089452353, has received the following waste material:

GENERATOR:	PORT OF TACOMA
MANIFEST #:	011880842JJK
CWM TRACKING ID:	42838501
PROFILE #:	OR321468
LINE ITEM:	9b.1
QUANTITY:	1 DT
RECEIVED DATE:	09/20/13
DISPOSAL PROCESS(ES):	LANDFILL
FINAL DISPOSAL LOCATION:	LANDFILL 13
DISPOSAL DATE:	09/20/13

I certify, on behalf of the above listed treatment facility, that to the best of my knowledge, the above-described waste material was managed in compliance with all applicable laws, regulations, permits and licenses on the date listed above.



CWMNW RECORDS DEPARTMENT

Date: 09/24/13



CHEMICAL WASTE MANAGEMENT OF THE NW

17629 Cedar Springs Lane
Arlington, OR 97812
(541) 454-2643
(541) 454-3279 Fax

PORT OF TACOMA
WAD001882984
3400 TAYLOR WAY
TACOMA WA 98421

CERTIFICATE OF DISPOSAL

Chemical Waste Management of the Northwest, Inc., ORD089452353, has received the following waste material:

GENERATOR:	PORT OF TACOMA
MANIFEST #:	011880839JJK
CWM TRACKING ID:	42838001
PROFILE #:	OR321468
LINE ITEM:	9b.1
QUANTITY:	1 DT
RECEIVED DATE:	09/20/13
DISPOSAL PROCESS(ES):	LANDFILL
FINAL DISPOSAL LOCATION:	LANDFILL 13
DISPOSAL DATE:	09/20/13

I certify, on behalf of the above listed treatment facility, that to the best of my knowledge, the above-described waste material was managed in compliance with all applicable laws, regulations, permits and licenses on the date listed above.

Robbi Dobalvin

CWMNW RECORDS DEPARTMENT

Date: 09/24/13



CHEMICAL WASTE MANAGEMENT OF THE NW

17629 Cedar Springs Lane
Arlington, OR 97812
(541) 454-2643
(541) 454-3279 Fax

PORT OF TACOMA
WAD001882984
3400 TAYLOR WAY
TACOMA WA 98421

CERTIFICATE OF DISPOSAL

Chemical Waste Management of the Northwest, Inc., ORD089452353, has received the following waste material:

GENERATOR:	PORT OF TACOMA
MANIFEST #:	011880837JJK
CWM TRACKING ID:	42837401
PROFILE #:	OR321468
LINE ITEM:	9b.1
QUANTITY:	1 DT
RECEIVED DATE:	09/20/13
DISPOSAL PROCESS(ES):	LANDFILL
FINAL DISPOSAL LOCATION:	LANDFILL 13
DISPOSAL DATE:	09/20/13

I certify, on behalf of the above listed treatment facility, that to the best of my knowledge, the above-described waste material was managed in compliance with all applicable laws, regulations, permits and licenses on the date listed above.



CWMNW RECORDS DEPARTMENT

Date: 09/24/13



CHEMICAL WASTE MANAGEMENT OF THE NW

17629 Cedar Springs Lane
Arlington, OR 97812
(541) 454-2643
(541) 454-3279 Fax

PORT OF TACOMA
WAD001882984
3400 TAYLOR WAY
TACOMA WA 98421

CERTIFICATE OF DISPOSAL

Chemical Waste Management of the Northwest, Inc., ORD089452353, has received the following waste material:

GENERATOR:	PORT OF TACOMA
MANIFEST #:	011880836JJK
CWM TRACKING ID:	42837501
PROFILE #:	OR321468
LINE ITEM:	9b.1
QUANTITY:	1 D7
RECEIVED DATE:	09/20/13
DISPOSAL PROCESS(ES):	LANDFILL
FINAL DISPOSAL LOCATION:	LANDFILL 13
DISPOSAL DATE:	09/20/13

I certify, on behalf of the above listed treatment facility, that to the best of my knowledge, the above-described waste material was managed in compliance with all applicable laws, regulations, permits and licenses on the date listed above.

Bobbi Jo Galvin

CWMNW RECORDS DEPARTMENT

Date: 09/24/13



CHEMICAL WASTE MANAGEMENT OF THE NW

17629 Cedar Springs Lane
Arlington, OR 97812
(541) 454-2643
(541) 454-3279 Fax

PORT OF TACOMA
WAD001882984
3400 TAYLOR WAY
TACOMA WA 98421

CERTIFICATE OF DISPOSAL

Chemical Waste Management of the Northwest, Inc., ORD089452353, has received the following waste material:

GENERATOR:	PORT OF TACOMA
MANIFEST #:	011880838JJK
CWM TRACKING ID:	42837701
PROFILE #:	OR321468
LINE ITEM:	9b.1
QUANTITY:	1 DT
RECEIVED DATE:	09/20/13
DISPOSAL PROCESS(ES):	LANDFILL
FINAL DISPOSAL LOCATION:	LANDFILL 13
DISPOSAL DATE:	09/20/13

I certify, on behalf of the above listed treatment facility, that to the best of my knowledge, the above-described waste material was managed in compliance with all applicable laws, regulations, permits and licenses on the date listed above.

CWMNW RECORDS DEPARTMENT

Date: 09/24/13



CHEMICAL WASTE MANAGEMENT OF THE NW

17629 Cedar Springs Lane
Arlington, OR 97812
(541) 454-2643
(541) 454-3279 Fax

PORT OF TACOMA
WAD001882984
3400 TAYLOR WAY
TACOMA WA 98421

CERTIFICATE OF DISPOSAL

Chemical Waste Management of the Northwest, Inc., ORD089452353, has received the following waste material:

GENERATOR:	PORT OF TACOMA
MANIFEST #:	011880845JJK
CWM TRACKING ID:	42833901
PROFILE #:	OR321468
LINE ITEM:	9b.1
QUANTITY:	1 DT
RECEIVED DATE:	09/20/13
DISPOSAL PROCESS(ES):	LANDFILL
FINAL DISPOSAL LOCATION:	LANDFILL 13
DISPOSAL DATE:	09/20/13

I certify, on behalf of the above listed treatment facility, that to the best of my knowledge, the above-described waste material was managed in compliance with all applicable laws, regulations, permits and licenses on the date listed above.

Bobbin Galvin

CWMNW RECORDS DEPARTMENT

Date: 09/24/13



CHEMICAL WASTE MANAGEMENT OF THE NW

17629 Cedar Springs Lane
Arlington, OR 97812
(541) 454-2643
(541) 454-3279 Fax

PORT OF TACOMA
WAD001882984
3400 TAYLOR WAY
TACOMA WA 98421

CERTIFICATE OF DISPOSAL

Chemical Waste Management of the Northwest, Inc., ORD089452353, has received the following waste material:

GENERATOR:	PORT OF TACOMA
MANIFEST #:	011880844JJK
CWM TRACKING ID:	42835901
PROFILE #:	OR321468
LINE ITEM:	9b.1
QUANTITY:	1 DT
RECEIVED DATE:	09/20/13
DISPOSAL PROCESS(ES):	LANDFILL
FINAL DISPOSAL LOCATION:	LANDFILL 13
DISPOSAL DATE:	09/20/13

I certify, on behalf of the above listed treatment facility, that to the best of my knowledge, the above-described waste material was managed in compliance with all applicable laws, regulations, permits and licenses on the date listed above.

Bobbi Galvin

CWMNW RECORDS DEPARTMENT
Date: 09/24/13



CHEMICAL WASTE MANAGEMENT OF THE NW

17629 Cedar Springs Lane
Arlington, OR 97812
(541) 454-2643
(541) 454-3279 Fax

PORT OF TACOMA
WAD001882984
3400 TAYLOR WAY
TACOMA WA 98421

CERTIFICATE OF DISPOSAL

Chemical Waste Management of the Northwest, Inc., ORD089452353, has received the following waste material:

GENERATOR:	PORT OF TACOMA
MANIFEST #:	011880800JJK
CWM TRACKING ID:	42847101
PROFILE #:	OR321468
LINE ITEM:	9b.1
QUANTITY:	1 DT
RECEIVED DATE:	09/23/13
DISPOSAL PROCESS(ES):	LANDFILL
FINAL DISPOSAL LOCATION:	LANDFILL 14
DISPOSAL DATE:	09/23/13

I certify, on behalf of the above listed treatment facility, that to the best of my knowledge, the above-described waste material was managed in compliance with all applicable laws, regulations, permits and licenses on the date listed above.

Bobbi J Galvin

CWMNW RECORDS DEPARTMENT

Date: 09/24/13



CHEMICAL WASTE MANAGEMENT OF THE NW

17629 Cedar Springs Lane
Arlington, OR 97812
(541) 454-2643
(541) 454-3279 Fax

PORT OF TACOMA
WAD001882984
3400 TAYLOR WAY
TACOMA WA 98421

CERTIFICATE OF DISPOSAL

Chemical Waste Management of the Northwest, Inc., ORD089452353, has received the following waste material:

GENERATOR:	PORT OF TACOMA
MANIFEST #:	011880807JJK
CWM TRACKING ID:	42847201
PROFILE #:	OR321468
LINE ITEM:	9b.1
QUANTITY:	1 DT
RECEIVED DATE:	09/23/13
DISPOSAL PROCESS(ES):	LANDFILL
FINAL DISPOSAL LOCATION:	LANDFILL 13
DISPOSAL DATE:	09/23/13

I certify, on behalf of the above listed treatment facility, that to the best of my knowledge, the above-described waste material was managed in compliance with all applicable laws, regulations, permits and licenses on the date listed above.

Bobbi Holalun

CWMNW RECORDS DEPARTMENT

Date: 09/24/13



CHEMICAL WASTE MANAGEMENT OF THE NW

17629 Cedar Springs Lane
Arlington, OR 97812
(541) 454-2643
(541) 454-3279 Fax

PORT OF TACOMA
WAD001882984
3400 TAYLOR WAY
TACOMA WA 98421

CERTIFICATE OF DISPOSAL

Chemical Waste Management of the Northwest, Inc., ORD089452353, has received the following waste material:

GENERATOR:	PORT OF TACOMA
MANIFEST #:	011880808JJK
CWM TRACKING ID:	42846601
PROFILE #:	OR321468
LINE ITEM:	9b.1
QUANTITY:	1 DT
RECEIVED DATE:	09/23/13
DISPOSAL PROCESS(ES):	LANDFILL
FINAL DISPOSAL LOCATION:	LANDFILL 13
DISPOSAL DATE:	09/23/13

I certify, on behalf of the above listed treatment facility, that to the best of my knowledge, the above-described waste material was managed in compliance with all applicable laws, regulations, permits and licenses on the date listed above.

Bobbi Jo Galvin

CWMNW RECORDS DEPARTMENT

Date: 09/24/13



CHEMICAL WASTE MANAGEMENT OF THE NW

17629 Cedar Springs Lane
Arlington, OR 97812
(541) 454-2643
(541) 454-3279 Fax

↓

PORT OF TACOMA
WAD001882984
3400 TAYLOR WAY
TACOMA WA 98421

CERTIFICATE OF DISPOSAL

Chemical Waste Management of the Northwest, Inc., ORD089452353, has received the following waste material:

GENERATOR:	PORT OF TACOMA
MANIFEST #:	011880809JJK
CWM TRACKING ID:	42846701
PROFILE #:	OR321468
LINE ITEM:	9b.1
QUANTITY:	1 DT
RECEIVED DATE:	09/23/13
DISPOSAL PROCESS(ES):	LANDFILL
FINAL DISPOSAL LOCATION:	LANDFILL 13
DISPOSAL DATE:	09/23/13

I certify, on behalf of the above listed treatment facility, that to the best of my knowledge, the above-described waste material was managed in compliance with all applicable laws, regulations, permits and licenses on the date listed above.

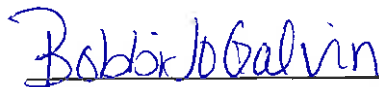

CWMNW RECORDS DEPARTMENT

Date: 09/24/13

↓



CHEMICAL WASTE MANAGEMENT OF THE NW

17629 Cedar Springs Lane
Arlington, OR 97812
(541) 454-2643
(541) 454-3279 Fax

PORT OF TACOMA
WAD001882984
3400 TAYLOR WAY
TACOMA WA 98421

CERTIFICATE OF DISPOSAL

Chemical Waste Management of the Northwest, Inc., ORD089452353, has received the following waste material:

GENERATOR:	PORT OF TACOMA
MANIFEST #:	011880830JJK
CWM TRACKING ID:	42846801
PROFILE #:	OR321468
LINE ITEM:	9b.1
QUANTITY:	1 D ⁺
RECEIVED DATE:	09/23/13
DISPOSAL PROCESS(ES):	LANDFILL
FINAL DISPOSAL LOCATION:	LANDFILL 13
DISPOSAL DATE:	09/23/13

I certify, on behalf of the above listed treatment facility, that to the best of my knowledge, the above-described waste material was managed in compliance with all applicable laws, regulations, permits and licenses on the date listed above.

Bobbi Jo Galvin

CWMNW RECORDS DEPARTMENT

Date: 09/24/13



CHEMICAL WASTE MANAGEMENT OF THE NW

17629 Cedar Springs Lane
Arlington, OR 97812
(541) 454-2643
(541) 454-3279 Fax

PORT OF TACOMA
WAD001882984
3400 TAYLOR WAY
TACOMA WA 98421

CERTIFICATE OF DISPOSAL

Chemical Waste Management of the Northwest, Inc., ORD089452353, has received the following waste material:

GENERATOR:	PORT OF TACOMA
MANIFEST #:	011880810JJK
CWM TRACKING ID:	42846401
PROFILE #:	OR321468
LINE ITEM:	9b.1
QUANTITY:	1 DT
RECEIVED DATE:	09/23/13
DISPOSAL PROCESS(ES):	LANDFILL
FINAL DISPOSAL LOCATION:	LANDFILL 13
DISPOSAL DATE:	09/23/13

I certify, on behalf of the above listed treatment facility, that to the best of my knowledge, the above-described waste material was managed in compliance with all applicable laws, regulations, permits and licenses on the date listed above.

Bobbi Jo Galvin

CWMNW RECORDS DEPARTMENT

Date: 09/24/13



CHEMICAL WASTE MANAGEMENT OF THE NW
 17629 Cedar Springs Lane
 Arlington, OR 97812
 (541) 454-2643
 (541) 454-3279 Fax

PORT OF TACOMA
 WAD001882984
 3400 TAYLOR WAY
 TACOMA WA 98421

↓
CERTIFICATE OF DISPOSAL

Chemical Waste Management of the Northwest, Inc., ORD089452353, has received the following waste material:

GENERATOR:	PORT OF TACOMA	
MANIFEST #:	011880811JJK	
CWM TRACKING ID:	42846201	
PROFILE #:	OR321468	
LINE ITEM:	9b.1	
QUANTITY:	1 DT	
RECEIVED DATE:	09/23/13	
DISPOSAL PROCESS(ES):	LANDFILL	
FINAL DISPOSAL LOCATION:	LANDFILL	13
DISPOSAL DATE:	09/23/13	

I certify, on behalf of the above listed treatment facility, that to the best of my knowledge, the above-described waste material was managed in compliance with all applicable laws, regulations, permits and licenses on the date listed above.

Bobbi Jo Galvin

CWMNW RECORDS DEPARTMENT
 Date: 09/24/13



CHEMICAL WASTE MANAGEMENT OF THE NW

17629 Cedar Springs Lane
Arlington, OR 97812
(541) 454-2643
(541) 454-3279 Fax

PORT OF TACOMA
WAD001882984
3400 TAYLOR WAY
TACOMA WA 98421

CERTIFICATE OF DISPOSAL

Chemical Waste Management of the Northwest, Inc., ORD089452353, has received the following waste material:

GENERATOR:	PORT OF TACOMA
MANIFEST #:	011880812JJK
CWM TRACKING ID:	42846101
PROFILE #:	OR321468
LINE ITEM:	9b.1
QUANTITY:	1 DT
RECEIVED DATE:	09/23/13
DISPOSAL PROCESS(ES):	LANDFILL
FINAL DISPOSAL LOCATION:	LANDFILL 13
DISPOSAL DATE:	09/23/13

I certify, on behalf of the above listed treatment facility, that to the best of my knowledge, the above-described waste material was managed in compliance with all applicable laws, regulations, permits and licenses on the date listed above.

Bobbi Jo Galvin

CWMNW RECORDS DEPARTMENT

Date: 09/24/13



CHEMICAL WASTE MANAGEMENT OF THE NW

17629 Cedar Springs Lane
Arlington, OR 97812
(541) 454-2643
(541) 454-3279 Fax

PORT OF TACOMA
WAD001882984
3400 TAYLOR WAY
TACOMA WA 98421

CERTIFICATE OF DISPOSAL

Chemical Waste Management of the Northwest, Inc., ORD089452353, has received the following waste material:

GENERATOR:	PORT OF TACOMA
MANIFEST #:	011880814JJK
CWM TRACKING ID:	42846001
PROFILE #:	OR321468
LINE ITEM:	9b.1
QUANTITY:	1 DT
RECEIVED DATE:	09/23/13
DISPOSAL PROCESS(ES):	LANDFILL
FINAL DISPOSAL LOCATION:	LANDFILL 13
DISPOSAL DATE:	09/23/13

I certify, on behalf of the above listed treatment facility, that to the best of my knowledge, the above-described waste material was managed in compliance with all applicable laws, regulations, permits and licenses on the date listed above.

Robbie Jo Galvin

CWMNW RECORDS DEPARTMENT

Date: 09/24/13



CHEMICAL WASTE MANAGEMENT OF THE NW

17629 Cedar Springs Lane
Arlington, OR 97812
(541) 454-2643
(541) 454-3279 Fax

PORT OF TACOMA
WAD001882984
3400 TAYLOR WAY
TACOMA WA 98421

↓

CERTIFICATE OF DISPOSAL

Chemical Waste Management of the Northwest, Inc., ORD089452353, has received the following waste material:

GENERATOR:	PORT OF TACOMA
MANIFEST #:	011880829JJK
CWM TRACKING ID:	42845801
PROFILE #:	OR321468
LINE ITEM:	9b.1
QUANTITY:	1 DT
RECEIVED DATE:	09/23/13
DISPOSAL PROCESS(ES):	LANDFILL
FINAL DISPOSAL LOCATION:	LANDFILL 13
DISPOSAL DATE:	09/23/13

I certify, on behalf of the above listed treatment facility, that to the best of my knowledge, the above-described waste material was managed in compliance with all applicable laws, regulations, permits and licenses on the date listed above.

Bobbi Jo Galvin

CWMNW RECORDS DEPARTMENT

Date: 09/24/13



CHEMICAL WASTE MANAGEMENT OF THE NW

17629 Cedar Springs Lane
Arlington, OR 97812
(541) 454-2643
(541) 454-3279 Fax

PORT OF TACOMA
WAD001882984
3400 TAYLOR WAY
TACOMA WA 98421

CERTIFICATE OF DISPOSAL

Chemical Waste Management of the Northwest, Inc., ORD089452353, has received the following waste material:

GENERATOR: PORT OF TACOMA
MANIFEST #: 011880826JJK
CWM TRACKING ID: 42845701
PROFILE #: OR321468
LINE ITEM: 9b.1
QUANTITY: 1 DT
RECEIVED DATE: 09/23/13

DISPOSAL PROCESS(ES): LANDFILL
FINAL DISPOSAL LOCATION: LANDFILL 13
DISPOSAL DATE: 09/23/13

I certify, on behalf of the above listed treatment facility, that to the best of my knowledge, the above-described waste material was managed in compliance with all applicable laws, regulations, permits and licenses on the date listed above.

Bobbin Galvin

CWMNW RECORDS DEPARTMENT

Date: 09/24/13



CHEMICAL WASTE MANAGEMENT OF THE NW

17629 Cedar Springs Lane
Arlington, OR 97812
(541) 454-2643
(541) 454-3279 Fax

PORT OF TACOMA
WAD001882984
3400 TAYLOR WAY
TACOMA WA 98421

CERTIFICATE OF DISPOSAL

Chemical Waste Management of the Northwest, Inc., ORD089452353, has received the following waste material:

GENERATOR:	PORT OF TACOMA
MANIFEST #:	011080825JJK
CWM TRACKING ID:	42845601
PROFILE #:	OR321468
LINE ITEM:	9b.1
QUANTITY:	1 DT
RECEIVED DATE:	09/23/13
DISPOSAL PROCESS(ES):	LANDFILL
FINAL DISPOSAL LOCATION:	LANDFILL 13
DISPOSAL DATE:	09/23/13

I certify, on behalf of the above listed treatment facility, that to the best of my knowledge, the above-described waste material was managed in compliance with all applicable laws, regulations, permits and licenses on the date listed above.

Bobbie Galvin

CWMNW RECORDS DEPARTMENT

Date: 09/24/13



CHEMICAL WASTE MANAGEMENT OF THE NW

17629 Cedar Springs Lane
Arlington, OR 97812
(541) 454-2643
(541) 454-3279 Fax

PORT OF TACOMA
WAD001882984
3400 TAYLOR WAY
TACOMA WA 98421

CERTIFICATE OF DISPOSAL

Chemical Waste Management of the Northwest, Inc., ORD089452353, has received the following waste material:

GENERATOR: PORT OF TACOMA
MANIFEST #: 011880828JJK
CWM TRACKING ID: 42845501
PROFILE #: OR321468
LINE ITEM: 9b.1
QUANTITY: 1 DT
RECEIVED DATE: 09/23/13

DISPOSAL PROCESS(ES): LANDFILL
FINAL DISPOSAL LOCATION: LANDFILL 13
DISPOSAL DATE: 09/23/13

I certify, on behalf of the above listed treatment facility, that to the best of my knowledge, the above-described waste material was managed in compliance with all applicable laws, regulations, permits and licenses on the date listed above.

Bobbi Jo Galvin

CWMNW RECORDS DEPARTMENT

Date: 09/24/13



CHEMICAL WASTE MANAGEMENT OF THE NW

17629 Cedar Springs Lane
Arlington, OR 97812
(541) 454-2643
(541) 454-3279 Fax

PORT OF TACOMA
WAD001882984
3400 TAYLOR WAY
TACOMA WA 98421

CERTIFICATE OF DISPOSAL

Chemical Waste Management of the Northwest, Inc., ORD089452353, has received the following waste material:

GENERATOR:	PORT OF TACOMA
MANIFEST #:	011880819JJK
CWM TRACKING ID:	42845101
PROFILE #:	OR321468
LINE ITEM:	9b.1
QUANTITY:	1 DT
RECEIVED DATE:	09/23/13
DISPOSAL PROCESS(ES):	LANDFILL
FINAL DISPOSAL LOCATION:	LANDFILL 13
DISPOSAL DATE:	09/23/13

I certify, on behalf of the above listed treatment facility, that to the best of my knowledge, the above-described waste material was managed in compliance with all applicable laws, regulations, permits and licenses on the date listed above.

Bobbi Jo Galvin

CWMNW RECORDS DEPARTMENT

Date: 09/24/13



CHEMICAL WASTE MANAGEMENT OF THE NW

17629 Cedar Springs Lane
Arlington, OR 97812
(541) 454-2643
(541) 454-3279 Fax

PORT OF TACOMA
WAD001882984
3400 TAYLOR WAY
TACOMA WA 98421

CERTIFICATE OF DISPOSAL

Chemical Waste Management of the Northwest, Inc., ORD089452353, has received the following waste material:

GENERATOR:	PORT OF TACOMA
MANIFEST #:	011880827JJK
CWM TRACKING ID:	42845001
PROFILE #:	OR321468
LINE ITEM:	9b.1
QUANTITY:	1 DT
RECEIVED DATE:	09/23/13
DISPOSAL PROCESS(ES):	LANDFILL
FINAL DISPOSAL LOCATION:	LANDFILL 13
DISPOSAL DATE:	09/23/13

I certify, on behalf of the above listed treatment facility, that to the best of my knowledge, the above-described waste material was managed in compliance with all applicable laws, regulations, permits and licenses on the date listed above.

Bobbi Jo Galvin

CWMNW RECORDS DEPARTMENT

Date: 09/24/13



CHEMICAL WASTE MANAGEMENT OF THE NW

17629 Cedar Springs Lane
Arlington, OR 97812
(541) 454-2643
(541) 454-3279 Fax

PORT OF TACOMA
WAD001882984
3400 TAYLOR WAY
TACOMA WA 98421

CERTIFICATE OF DISPOSAL

Chemical Waste Management of the Northwest, Inc., ORD089452353, has received the following waste material:

GENERATOR: PORT OF TACOMA
MANIFEST #: 011880815JJK
CWM TRACKING ID: 42844901
PROFILE #: OR321468
LINE ITEM: 9b.1
QUANTITY: 1 D7
RECEIVED DATE: 09/23/13

DISPOSAL PROCESS(ES): LANDFILL
FINAL DISPOSAL LOCATION: LANDFILL 13
DISPOSAL DATE: 09/23/13

I certify, on behalf of the above listed treatment facility, that to the best of my knowledge, the above-described waste material was managed in compliance with all applicable laws, regulations, permits and licenses on the date listed above.

Bobbi Jo Galvin

CWMNW RECORDS DEPARTMENT

Date: 09/24/13



CHEMICAL WASTE MANAGEMENT OF THE NW

17629 Cedar Springs Lane
Arlington, OR 97812
(541) 454-2643
(541) 454-3279 Fax

PORT OF TACOMA
WAD001882984
3400 TAYLOR WAY
TACOMA WA 98421

CERTIFICATE OF DISPOSAL

Chemical Waste Management of the Northwest, Inc., ORD089452353, has received the following waste material:

GENERATOR: PORT OF TACOMA
MANIFEST #: 011880817JJK
CWM TRACKING ID: 42844801
PROFILE #: OR321468
LINE ITEM: 9b.1
QUANTITY: 1 DT
RECEIVED DATE: 09/23/13

DISPOSAL PROCESS(ES): LANDFILL
FINAL DISPOSAL LOCATION: LANDFILL 13
DISPOSAL DATE: 09/23/13

I certify, on behalf of the above listed treatment facility, that to the best of my knowledge, the above-described waste material was managed in compliance with all applicable laws, regulations, permits and licenses on the date listed above.

Bobbi Jo Galvin

CWMNW RECORDS DEPARTMENT
Date: 09/24/13



CHEMICAL WASTE MANAGEMENT OF THE NW

17629 Cedar Springs Lane
Arlington, OR 97812
(541) 454-2643
(541) 454-3279 Fax

PORT OF TACOMA
WAD001882984
3400 TAYLOR WAY
TACOMA WA 98421

CERTIFICATE OF DISPOSAL

Chemical Waste Management of the Northwest, Inc., ORD089452353, has received the following waste material:

GENERATOR:	PORT OF TACOMA
MANIFEST #:	011880818JJK
CWM TRACKING ID:	42844601
PROFILE #:	OR321468
LINE ITEM:	9b.1
QUANTITY:	1 DT
RECEIVED DATE:	09/23/13
DISPOSAL PROCESS(ES):	LANDFILL
FINAL DISPOSAL LOCATION:	LANDFILL 13
DISPOSAL DATE:	09/23/13

I certify, on behalf of the above listed treatment facility, that to the best of my knowledge, the above-described waste material was managed in compliance with all applicable laws, regulations, permits and licenses on the date listed above.

CWMNW RECORDS DEPARTMENT

Date: 09/24/13



CHEMICAL WASTE MANAGEMENT OF THE NW

17629 Cedar Springs Lane
Arlington, OR 97812
(541) 454-2643
(541) 454-3279 Fax

PORT OF TACOMA
WAD001882984
3400 TAYLOR WAY
TACOMA WA 98421

CERTIFICATE OF DISPOSAL

Chemical Waste Management of the Northwest, Inc., ORD089452353, has received the following waste material:

GENERATOR:	PORT OF TACOMA
MANIFEST #:	011880823JJK
CWM TRACKING ID:	42844301
PROFILE #:	OR321468
LINE ITEM:	9b.1
QUANTITY:	1 DT
RECEIVED DATE:	09/23/13
DISPOSAL PROCESS(ES):	LANDFILL
FINAL DISPOSAL LOCATION:	LANDFILL 13
DISPOSAL DATE:	09/23/13

I certify, on behalf of the above listed treatment facility, that to the best of my knowledge, the above-described waste material was managed in compliance with all applicable laws, regulations, permits and licenses on the date listed above.

CWMNW RECORDS DEPARTMENT

Date: 09/24/13



CHEMICAL WASTE MANAGEMENT OF THE NW

17629 Cedar Springs Lane
Arlington, OR 97812
(541) 454-2643
(541) 454-3279 Fax

PORT OF TACOMA
WAD001882984
3400 TAYLOR WAY
TACOMA WA 98421

CERTIFICATE OF DISPOSAL

Chemical Waste Management of the Northwest, Inc., ORD089452353, has received the following waste material:

GENERATOR:	PORT OF TACOMA
MANIFEST #:	011880820JJK
CWM TRACKING ID:	42844201
PROFILE #:	OR321468
LINE ITEM:	9b.1
QUANTITY:	1 D ⁺
RECEIVED DATE:	09/23/13
DISPOSAL PROCESS(ES):	LANDFILL
FINAL DISPOSAL LOCATION:	LANDFILL 13
DISPOSAL DATE:	09/23/13

I certify, on behalf of the above listed treatment facility, that to the best of my knowledge, the above-described waste material was managed in compliance with all applicable laws, regulations, permits and licenses on the date listed above.



CWMNW RECORDS DEPARTMENT

Date: 09/24/13



CHEMICAL WASTE MANAGEMENT OF THE NW

17629 Cedar Springs Lane
Arlington, OR 97812
(541) 454-2643
(541) 454-3279 Fax

PORT OF TACOMA
WAD001882984
3400 TAYLOR WAY
TACOMA WA 98421

CERTIFICATE OF DISPOSAL

Chemical Waste Management of the Northwest, Inc., ORD089452353, has received the following waste material:

GENERATOR:	PORT OF TACOMA
MANIFEST #:	011880821JJK
CWM TRACKING ID:	42844101
PROFILE #:	OR321468
LINE ITEM:	9b.1
QUANTITY:	1 DT
RECEIVED DATE:	09/23/13
DISPOSAL PROCESS(ES):	LANDFILL
FINAL DISPOSAL LOCATION:	LANDFILL 13
DISPOSAL DATE:	09/23/13

I certify, on behalf of the above listed treatment facility, that to the best of my knowledge, the above-described waste material was managed in compliance with all applicable laws, regulations, permits and licenses on the date listed above.



CWMNW RECORDS DEPARTMENT

Date: 09/24/13



CHEMICAL WASTE MANAGEMENT OF THE NW

17629 Cedar Springs Lane
Arlington, OR 97812
(541) 454-2643
(541) 454-3279 Fax

PORT OF TACOMA
WAD001882984
3400 TAYLOR WAY
TACOMA WA 98421

CERTIFICATE OF DISPOSAL

Chemical Waste Management of the Northwest, Inc., ORD089452353, has received the following waste material:

GENERATOR:	PORT OF TACOMA
MANIFEST #:	011880822JJK
CWM TRACKING ID:	42844001
PROFILE #:	OR321468
LINE ITEM:	9b.1
QUANTITY:	1 DT
RECEIVED DATE:	09/23/13
DISPOSAL PROCESS(ES):	LANDFILL
FINAL DISPOSAL LOCATION:	LANDFILL 13
DISPOSAL DATE:	09/23/13

I certify, on behalf of the above listed treatment facility, that to the best of my knowledge, the above-described waste material was managed in compliance with all applicable laws, regulations, permits and licenses on the date listed above.

Bobbie Kalvin

CWMNW RECORDS DEPARTMENT

Date: 09/24/13



CHEMICAL WASTE MANAGEMENT OF THE NW

17629 Cedar Springs Lane
Arlington, OR 97812
(541) 454-2643
(541) 454-3279 Fax

PORT OF TACOMA
WAD001882984
3400 TAYLOR WAY
TACOMA WA 98421

CERTIFICATE OF DISPOSAL

Chemical Waste Management of the Northwest, Inc., ORD089452353, has received the following waste material:

GENERATOR:	PORT OF TACOMA
MANIFEST #:	011880824JJK
CWM TRACKING ID:	42843801
PROFILE #:	OR321468
LINE ITEM:	9b.1
QUANTITY:	1 DT
RECEIVED DATE:	09/23/13
DISPOSAL PROCESS(ES):	LANDFILL
FINAL DISPOSAL LOCATION:	LANDFILL 13
DISPOSAL DATE:	09/23/13

I certify, on behalf of the above listed treatment facility, that to the best of my knowledge, the above-described waste material was managed in compliance with all applicable laws, regulations, permits and licenses on the date listed above.

Bobbi Jo Galvin

CWMNW RECORDS DEPARTMENT
Date: 09/24/13



CHEMICAL WASTE MANAGEMENT OF THE NW

17629 Cedar Springs Lane
Arlington, OR 97812
(541) 454-2643
(541) 454-3279 Fax

PORT OF TACOMA
WAD001882984
3400 TAYLOR WAY
TACOMA WA 98421

CERTIFICATE OF DISPOSAL

Chemical Waste Management of the Northwest, Inc., ORD089452353, has received the following waste material:

GENERATOR:	PORT OF TACOMA
MANIFEST #:	011880813JJK
CWM TRACKING ID:	42845901
PROFILE #:	OR321468
LINE ITEM:	9b.1
QUANTITY:	1 DT
RECEIVED DATE:	09/23/13
DISPOSAL PROCESS(ES):	LANDFILL
FINAL DISPOSAL LOCATION:	LANDFILL 13
DISPOSAL DATE:	09/23/13

I certify, on behalf of the above listed treatment facility, that to the best of my knowledge, the above-described waste material was managed in compliance with all applicable laws, regulations, permits and licenses on the date listed above.

CWMNW RECORDS DEPARTMENT

Date: 09/30/13



CHEMICAL WASTE MANAGEMENT OF THE NW

17629 Cedar Springs Lane
Arlington, OR 97812
(541) 454-2643
(541) 454-3279 Fax

PORT OF TACOMA
WAD001882984
3400 TAYLOR WAY
TACOMA WA 98421

CERTIFICATE OF DISPOSAL

Chemical Waste Management of the Northwest, Inc., ORD089452353, has received the following waste material:

GENERATOR:	PORT OF TACOMA
MANIFEST #:	011880816JJK
CWM TRACKING ID:	42845301
PROFILE #:	OR321468
LINE ITEM:	9b.1
QUANTITY:	1 DT
RECEIVED DATE:	09/23/13
DISPOSAL PROCESS(ES):	LANDFILL
FINAL DISPOSAL LOCATION:	LANDFILL 13
DISPOSAL DATE:	09/23/13

I certify, on behalf of the above listed treatment facility, that to the best of my knowledge, the above-described waste material was managed in compliance with all applicable laws, regulations, permits and licenses on the date listed above.

Robbi Jo Galvin

CWMNW RECORDS DEPARTMENT

Date: 09/24/13



CHEMICAL WASTE MANAGEMENT OF THE NW

17629 Cedar Springs Lane
Arlington, OR 97812
(541) 454-2643
(541) 454-3279 Fax

PORT OF TACOMA
WAD001882984
3400 TAYLOR WAY
TACOMA WA 98421

CERTIFICATE OF DISPOSAL

Chemical Waste Management of the Northwest, Inc., ORD089452353, has received the following waste material:

GENERATOR:	PORT OF TACOMA	
MANIFEST #:	011880977JJK	
CWM TRACKING ID:	42854001	
PROFILE #:	OR321468	
LINE ITEM:	9b.1	
QUANTITY:	1 DT	
RECEIVED DATE:	09/24/13	
DISPOSAL PROCESS(ES):	LANDFILL	
FINAL DISPOSAL LOCATION:	LANDFILL	13
DISPOSAL DATE:	09/24/13	

I certify, on behalf of the above listed treatment facility, that to the best of my knowledge, the above-described waste material was managed in compliance with all applicable laws, regulations, permits and licenses on the date listed above.

Bobbi Jo Galvin

CWMNW RECORDS DEPARTMENT

Date: 09/30/13



CHEMICAL WASTE MANAGEMENT OF THE NW

17629 Cedar Springs Lane
Arlington, OR 97812
(541) 454-2643
(541) 454-3279 Fax

PORT OF TACOMA
WAD001882984
3400 TAYLOR WAY
TACOMA WA 98421

CERTIFICATE OF DISPOSAL

Chemical Waste Management of the Northwest, Inc., ORD089452353, has received the following waste material:

GENERATOR:	PORT OF TACOMA
MANIFEST #:	011880976JJK
CWM TRACKING ID:	42853901
PROFILE #:	OR321468
LINE ITEM:	9b.1
QUANTITY:	1 DT
RECEIVED DATE:	09/24/13
DISPOSAL PROCESS(ES):	LANDFILL
FINAL DISPOSAL LOCATION:	LANDFILL 13
DISPOSAL DATE:	09/24/13

I certify, on behalf of the above listed treatment facility, that to the best of my knowledge, the above-described waste material was managed in compliance with all applicable laws, regulations, permits and licenses on the date listed above.

Bobbi Sobalvin

CWMNW RECORDS DEPARTMENT

Date: 09/30/13



CHEMICAL WASTE MANAGEMENT OF THE NW

17629 Cedar Springs Lane
Arlington, OR 97812
(541) 454-2643
(541) 454-3279 Fax

PORT OF TACOMA
WAD001882984
3400 TAYLOR WAY
TACOMA WA 98421

CERTIFICATE OF DISPOSAL

Chemical Waste Management of the Northwest, Inc., ORD089452353, has received the following waste material:

GENERATOR:	PORT OF TACOMA
MANIFEST #:	011880981JJK
CWM TRACKING ID:	42853501
PROFILE #:	OR321468
LINE ITEM:	9b.1
QUANTITY:	1 DT
RECEIVED DATE:	09/24/13
DISPOSAL PROCESS(ES):	LANDFILL
FINAL DISPOSAL LOCATION:	LANDFILL 13
DISPOSAL DATE:	09/24/13

I certify, on behalf of the above listed treatment facility, that to the best of my knowledge, the above-described waste material was managed in compliance with all applicable laws, regulations, permits and licenses on the date listed above.



CWMNW RECORDS DEPARTMENT
Date: 09/30/13



CHEMICAL WASTE MANAGEMENT OF THE NW

17629 Cedar Springs Lane
Arlington, OR 97812
(541) 454-2643
(541) 454-3279 Fax

PORT OF TACOMA
WAD001882984
3400 TAYLOR WAY
TACOMA WA 98421

CERTIFICATE OF DISPOSAL

Chemical Waste Management of the Northwest, Inc., ORD089452353, has received the following waste material:

GENERATOR:	PORT OF TACOMA
MANIFEST #:	011880975JJK
CWM TRACKING ID:	42853301
PROFILE #:	OR321468
LINE ITEM:	9b.1
QUANTITY:	1 DT
RECEIVED DATE:	09/24/13
DISPOSAL PROCESS(ES):	LANDFILL
FINAL DISPOSAL LOCATION:	LANDFILL 13
DISPOSAL DATE:	09/24/13

I certify, on behalf of the above listed treatment facility, that to the best of my knowledge, the above-described waste material was managed in compliance with all applicable laws, regulations, permits and licenses on the date listed above.

CWMNW RECORDS DEPARTMENT

Date: 09/30/13



CHEMICAL WASTE MANAGEMENT OF THE NW

17629 Cedar Springs Lane
Arlington, OR 97812
(541) 454-2643
(541) 454-3279 Fax

PORT OF TACOMA
WAD001882984
3400 TAYLOR WAY
TACOMA WA 98421

CERTIFICATE OF DISPOSAL

Chemical Waste Management of the Northwest, Inc., ORD089452353, has received the following waste material:

GENERATOR:	PORT OF TACOMA
MANIFEST #:	01880974JJK
CWM TRACKING ID:	42853201
PROFILE #:	OR321468
LINE ITEM:	9b.1
QUANTITY:	1 DT
RECEIVED DATE:	09/24/13
DISPOSAL PROCESS(ES):	LANDFILL
FINAL DISPOSAL LOCATION:	LANDFILL 13
DISPOSAL DATE:	09/24/13

I certify, on behalf of the above listed treatment facility, that to the best of my knowledge, the above-described waste material was managed in compliance with all applicable laws, regulations, permits and licenses on the date listed above.

Bobbi J. Galvin

CWMNW RECORDS DEPARTMENT

Date: 09/30/13



CHEMICAL WASTE MANAGEMENT OF THE NW

17629 Cedar Springs Lane
Arlington, OR 97812
(541) 454-2643
(541) 454-3279 Fax

PORT OF TACOMA
WAD001882984
3400 TAYLOR WAY
TACOMA WA 98421

CERTIFICATE OF DISPOSAL

Chemical Waste Management of the Northwest, Inc., ORD089452353, has received the following waste material:

GENERATOR:	PORT OF TACOMA
MANIFEST #:	011880667JJK
CWM TRACKING ID:	42852701
PROFILE #:	OR321468
LINE ITEM:	9b.1
QUANTITY:	1 DT
RECEIVED DATE:	09/24/13
DISPOSAL PROCESS(ES):	LANDFILL
FINAL DISPOSAL LOCATION:	LANDFILL 13
DISPOSAL DATE:	09/24/13

I certify, on behalf of the above listed treatment facility, that to the best of my knowledge, the above-described waste material was managed in compliance with all applicable laws, regulations, permits and licenses on the date listed above.

Bobbi Jo Galvin _____

CWMNW RECORDS DEPARTMENT

Date: 09/30/13



CHEMICAL WASTE MANAGEMENT OF THE NW

17629 Cedar Springs Lane
Arlington, OR 97812
(541) 454-2643
(541) 454-3279 Fax

PORT OF TACOMA
WAD001882984
3400 TAYLOR WAY
TACOMA WA 98421

CERTIFICATE OF DISPOSAL

Chemical Waste Management of the Northwest, Inc., ORD089452353, has received the following waste material:

GENERATOR:	PORT OF TACOMA
MANIFEST #:	011880978JJK
CWM TRACKING ID:	42852301
PROFILE #:	OR321468
LINE ITEM:	9b.1
QUANTITY:	1 DT
RECEIVED DATE:	09/24/13
DISPOSAL PROCESS(ES):	LANDFILL
FINAL DISPOSAL LOCATION:	LANDFILL 13
DISPOSAL DATE:	09/24/13

I certify, on behalf of the above listed treatment facility, that to the best of my knowledge, the above-described waste material was managed in compliance with all applicable laws, regulations, permits and licenses on the date listed above.

Bobbi Jo Galvin _____

CWMNW RECORDS DEPARTMENT

Date: 09/30/13





CHEMICAL WASTE MANAGEMENT OF THE NW

17629 Cedar Springs Lane
Arlington, OR 97812
(541) 454-2643
(541) 454-3279 Fax

PORT OF TACOMA
WAD001882984
3400 TAYLOR WAY
TACOMA WA 98421

CERTIFICATE OF DISPOSAL

Chemical Waste Management of the Northwest, Inc., ORD089452353, has received the following waste material:

GENERATOR:	PORT OF TACOMA
MANIFEST #:	011880659JJK
CWM TRACKING ID:	42852201
PROFILE #:	OR321468
LINE ITEM:	9b.1
QUANTITY:	1 DT
RECEIVED DATE:	09/24/13
DISPOSAL PROCESS(ES):	LANDFILL
FINAL DISPOSAL LOCATION:	LANDFILL 13
DISPOSAL DATE:	09/24/13

I certify, on behalf of the above listed treatment facility, that to the best of my knowledge, the above-described waste material was managed in compliance with all applicable laws, regulations, permits and licenses on the date listed above.

Bobbi Jofalvin

CWMNW RECORDS DEPARTMENT

Date: 09/30/13



CHEMICAL WASTE MANAGEMENT OF THE NW

17629 Cedar Springs Lane
Arlington, OR 97812
(541) 454-2643
(541) 454-3279 Fax

PORT OF TACOMA
WAD001882984
3400 TAYLOR WAY
TACOMA WA 98421

CERTIFICATE OF DISPOSAL

Chemical Waste Management of the Northwest, Inc., ORD089452353, has received the following waste material:

GENERATOR:	PORT OF TACOMA
MANIFEST #:	011880656JJK
CWM TRACKING ID:	42852101
PROFILE #:	OR321468
LINE ITEM:	9b.1
QUANTITY:	1 DT
RECEIVED DATE:	09/24/13
DISPOSAL PROCESS(ES):	LANDFILL
FINAL DISPOSAL LOCATION:	LANDFILL 13
DISPOSAL DATE:	09/24/13

I certify, on behalf of the above listed treatment facility, that to the best of my knowledge, the above-described waste material was managed in compliance with all applicable laws, regulations, permits and licenses on the date listed above.

Bubbio Galvin _____

CWMNW RECORDS DEPARTMENT

Date: 09/30/13



CHEMICAL WASTE MANAGEMENT OF THE NW

17629 Cedar Springs Lane
Arlington, OR 97812
(541) 454-2643
(541) 454-3279 Fax

PORT OF TACOMA
WAD001882984
3400 TAYLOR WAY
TACOMA WA 98421

CERTIFICATE OF DISPOSAL

Chemical Waste Management of the Northwest, Inc., ORD089452353, has received the following waste material:

GENERATOR:	PORT OF TACOMA
MANIFEST #:	011880658JJK
CWM TRACKING ID:	42852001
PROFILE #:	OR321468
LINE ITEM:	9b.1
QUANTITY:	1 DT
RECEIVED DATE:	09/24/13
DISPOSAL PROCESS(ES):	LANDFILL
FINAL DISPOSAL LOCATION:	LANDFILL 13
DISPOSAL DATE:	09/24/13

I certify, on behalf of the above listed treatment facility, that to the best of my knowledge, the above-described waste material was managed in compliance with all applicable laws, regulations, permits and licenses on the date listed above.

Bobbi Jo Aralun

CWMNW RECORDS DEPARTMENT

Date: 09/30/13



CHEMICAL WASTE MANAGEMENT OF THE NW

17629 Cedar Springs Lane
Arlington, OR 97812
(541) 454-2643
(541) 454-3279 Fax

PORT OF TACOMA
WAD001882984
3400 TAYLOR WAY
TACOMA WA 98421

CERTIFICATE OF DISPOSAL

Chemical Waste Management of the Northwest, Inc., ORD089452353, has received the following waste material:

GENERATOR:	PORT OF TACOMA
MANIFEST #:	011880636JJK
CWM TRACKING ID:	42851901
PROFILE #:	OR321468
LINE ITEM:	9b.1
QUANTITY:	1 DT
RECEIVED DATE:	09/24/13
DISPOSAL PROCESS(ES):	LANDFILL
FINAL DISPOSAL LOCATION:	LANDFILL 13
DISPOSAL DATE:	09/24/13

I certify, on behalf of the above listed treatment facility, that to the best of my knowledge, the above-described waste material was managed in compliance with all applicable laws, regulations, permits and licenses on the date listed above.



CWMNW RECORDS DEPARTMENT

Date: 09/30/13



CHEMICAL WASTE MANAGEMENT OF THE NW

17629 Cedar Springs Lane
Arlington, OR 97812
(541) 454-2643
(541) 454-3279 Fax

PORT OF TACOMA
WAD001882984
3400 TAYLOR WAY
TACOMA WA 98421

CERTIFICATE OF DISPOSAL

Chemical Waste Management of the Northwest, Inc., ORD089452353, has received the following waste material:

GENERATOR:	PORT OF TACOMA
MANIFEST #:	011880665JJK
CWM TRACKING ID:	42851801
PROFILE #:	OR321468
LINE ITEM:	9b.1
QUANTITY:	1 DT
RECEIVED DATE:	09/24/13
DISPOSAL PROCESS(ES):	LANDFILL
FINAL DISPOSAL LOCATION:	LANDFILL 13
DISPOSAL DATE:	09/24/13

I certify, on behalf of the above listed treatment facility, that to the best of my knowledge, the above-described waste material was managed in compliance with all applicable laws, regulations, permits and licenses on the date listed above.

Bobbi Jofalvin _____

CWMNW RECORDS DEPARTMENT

Date: 09/30/13



CHEMICAL WASTE MANAGEMENT OF THE NW

17629 Cedar Springs Lane
Arlington, OR 97812
(541) 454-2643
(541) 454-3279 Fax

PORT OF TACOMA
WAD001882984
3400 TAYLOR WAY
TACOMA WA 98421

CERTIFICATE OF DISPOSAL

Chemical Waste Management of the Northwest, Inc., ORD089452353, has received the following waste material:

GENERATOR:	PORT OF TACOMA
MANIFEST #:	011880666JJK
CWM TRACKING ID:	42851701
PROFILE #:	OR321468
LINE ITEM:	9b.1
QUANTITY:	1 DT
RECEIVED DATE:	09/24/13
DISPOSAL PROCESS(ES):	LANDFILL
FINAL DISPOSAL LOCATION:	LANDFILL 13
DISPOSAL DATE:	09/24/13

I certify, on behalf of the above listed treatment facility, that to the best of my knowledge, the above-described waste material was managed in compliance with all applicable laws, regulations, permits and licenses on the date listed above.



CWMNW RECORDS DEPARTMENT

Date: 09/30/13



CHEMICAL WASTE MANAGEMENT OF THE NW

17629 Cedar Springs Lane
Arlington, OR 97812
(541) 454-2643
(541) 454-3279 Fax

PORT OF TACOMA
WAD001882984
3400 TAYLOR WAY
TACOMA WA 98421

CERTIFICATE OF DISPOSAL

Chemical Waste Management of the Northwest, Inc., ORD089452353, has received the following waste material:

GENERATOR:	PORT OF TACOMA
MANIFEST #:	011880663JJK
CWM TRACKING ID:	42851501
PROFILE #:	OR321468
LINE ITEM:	9b.1
QUANTITY:	1 D ³
RECEIVED DATE:	09/24/13
DISPOSAL PROCESS(ES):	LANDFILL
FINAL DISPOSAL LOCATION:	LANDFILL 13
DISPOSAL DATE:	09/24/13

I certify, on behalf of the above listed treatment facility, that to the best of my knowledge, the above-described waste material was managed in compliance with all applicable laws, regulations, permits and licenses on the date listed above.



CWMNW RECORDS DEPARTMENT

Date: 09/30/13



CHEMICAL WASTE MANAGEMENT OF THE NW

17629 Cedar Springs Lane
Arlington, OR 97812
(541) 454-2643
(541) 454-3279 Fax

PORT OF TACOMA
WAD001882984
3400 TAYLOR WAY
TACOMA WA 98421

CERTIFICATE OF DISPOSAL

Chemical Waste Management of the Northwest, Inc., ORD089452353, has received the following waste material:

GENERATOR:	PORT OF TACOMA
MANIFEST #:	011880638JJK
CWM TRACKING ID:	42851401
PROFILE #:	OR321468
LINE ITEM:	9b.1
QUANTITY:	1 DT
RECEIVED DATE:	09/24/13
DISPOSAL PROCESS(ES):	LANDFILL
FINAL DISPOSAL LOCATION:	LANDFILL 13
DISPOSAL DATE:	09/24/13

I certify, on behalf of the above listed treatment facility, that to the best of my knowledge, the above-described waste material was managed in compliance with all applicable laws, regulations, permits and licenses on the date listed above.



CWMNW RECORDS DEPARTMENT

Date: 09/30/13



CHEMICAL WASTE MANAGEMENT OF THE NW

17629 Cedar Springs Lane
Arlington, OR 97812
(541) 454-2643
(541) 454-3279 Fax

PORT OF TACOMA
WAD001882984
3400 TAYLOR WAY
TACOMA WA 98421

CERTIFICATE OF DISPOSAL

Chemical Waste Management of the Northwest, Inc., ORD089452353, has received the following waste material:

GENERATOR:	PORT OF TACOMA
MANIFEST #:	011880632JJK
CWM TRACKING ID:	42851201
PROFILE #:	OR321468
LINE ITEM:	9b.1
QUANTITY:	1 DT
RECEIVED DATE:	09/24/13
DISPOSAL PROCESS(ES):	LANDFILL
FINAL DISPOSAL LOCATION:	LANDFILL 13
DISPOSAL DATE:	09/24/13

I certify, on behalf of the above listed treatment facility, that to the best of my knowledge, the above-described waste material was managed in compliance with all applicable laws, regulations, permits and licenses on the date listed above.

CWMNW RECORDS DEPARTMENT
Date: 09/30/13



CHEMICAL WASTE MANAGEMENT OF THE NW

17629 Cedar Springs Lane
Arlington, OR 97812
(541) 454-2643
(541) 454-3279 Fax

PORT OF TACOMA
WAD001882984
3400 TAYLOR WAY
TACOMA WA 98421

CERTIFICATE OF DISPOSAL

Chemical Waste Management of the Northwest, Inc., ORD089452353, has received the following waste material:

GENERATOR:	PORT OF TACOMA
MANIFEST #:	011880633JJK
CWM TRACKING ID:	42851101
PROFILE #:	OR321468
LINE ITEM:	9b.1
QUANTITY:	1 DT
RECEIVED DATE:	09/24/13
DISPOSAL PROCESS(ES):	LANDFILL
FINAL DISPOSAL LOCATION:	LANDFILL 13
DISPOSAL DATE:	09/24/13

I certify, on behalf of the above listed treatment facility, that to the best of my knowledge, the above-described waste material was managed in compliance with all applicable laws, regulations, permits and licenses on the date listed above.



CWMNW RECORDS DEPARTMENT

Date: 09/30/13



CHEMICAL WASTE MANAGEMENT OF THE NW

17629 Cedar Springs Lane
Arlington, OR 97812
(541) 454-2643
(541) 454-3279 Fax

PORT OF TACOMA
WAD001882984
3400 TAYLOR WAY
TACOMA WA 98421

CERTIFICATE OF DISPOSAL

Chemical Waste Management of the Northwest, Inc., ORD089452353, has received the following waste material:

GENERATOR:	PORT OF TACOMA
MANIFEST #:	011880801JJK
CWM TRACKING ID:	42850901
PROFILE #:	OR321468
LINE ITEM:	9b.1
QUANTITY:	1 DT
RECEIVED DATE:	09/24/13
DISPOSAL PROCESS(ES):	LANDFILL
FINAL DISPOSAL LOCATION:	LANDFILL 13
DISPOSAL DATE:	09/24/13

I certify, on behalf of the above listed treatment facility, that to the best of my knowledge, the above-described waste material was managed in compliance with all applicable laws, regulations, permits and licenses on the date listed above.



CWMNW RECORDS DEPARTMENT

Date: 09/30/13



CHEMICAL WASTE MANAGEMENT OF THE NW

17629 Cedar Springs Lane
Arlington, OR 97812
(541) 454-2643
(541) 454-3279 Fax

PORT OF TACOMA
WAD001882984
3400 TAYLOR WAY
TACOMA WA 98421

CERTIFICATE OF DISPOSAL

Chemical Waste Management of the Northwest, Inc., ORD089452353, has received the following waste material:

GENERATOR:	PORT OF TACOMA
MANIFEST #:	011880802JJK
CWM TRACKING ID:	42850801
PROFILE #:	OR321468
LINE ITEM:	9b.1
QUANTITY:	1 D1
RECEIVED DATE:	09/24/13
DISPOSAL PROCESS(ES):	LANDFILL
FINAL DISPOSAL LOCATION:	LANDFILL 13
DISPOSAL DATE:	09/24/13

I certify, on behalf of the above listed treatment facility, that to the best of my knowledge, the above-described waste material was managed in compliance with all applicable laws, regulations, permits and licenses on the date listed above.

Bobbi Jo Galvin

CWMNW RECORDS DEPARTMENT

Date: 09/30/13



CHEMICAL WASTE MANAGEMENT OF THE NW

17629 Cedar Springs Lane
Arlington, OR 97812
(541) 454-2643
(541) 454-3279 Fax

PORT OF TACOMA
WAD001882984
3400 TAYLOR WAY
TACOMA WA 98421

CERTIFICATE OF DISPOSAL

Chemical Waste Management of the Northwest, Inc., ORD089452353, has received the following waste material:

GENERATOR:	PORT OF TACOMA
MANIFEST #:	011880805JJK
CWM TRACKING ID:	42850401
PROFILE #:	OR321468
LINE ITEM:	9b.1
QUANTITY:	1 DT
RECEIVED DATE:	09/24/13
DISPOSAL PROCESS(ES):	LANDFILL
FINAL DISPOSAL LOCATION:	LANDFILL 13
DISPOSAL DATE:	09/24/13

I certify, on behalf of the above listed treatment facility, that to the best of my knowledge, the above-described waste material was managed in compliance with all applicable laws, regulations, permits and licenses on the date listed above.

 _____

CWMNW RECORDS DEPARTMENT

Date: 09/30/13



CHEMICAL WASTE MANAGEMENT OF THE NW

17629 Cedar Springs Lane
Arlington, OR 97812
(541) 454-2643
(541) 454-3279 Fax

PORT OF TACOMA
WAD001882984
3400 TAYLOR WAY
TACOMA WA 98421

CERTIFICATE OF DISPOSAL

Chemical Waste Management of the Northwest, Inc., ORD089452353, has received the following waste material:

GENERATOR:	PORT OF TACOMA
MANIFEST #:	011880804JJK
CWM TRACKING ID:	42850301
PROFILE #:	OR321468
LINE ITEM:	9b.1
QUANTITY:	1 DT
RECEIVED DATE:	09/24/13
DISPOSAL PROCESS(ES):	LANDFILL
FINAL DISPOSAL LOCATION:	LANDFILL 13
DISPOSAL DATE:	09/24/13

I certify, on behalf of the above listed treatment facility, that to the best of my knowledge, the above-described waste material was managed in compliance with all applicable laws, regulations, permits and licenses on the date listed above.

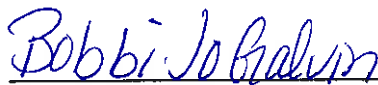

CWMNW RECORDS DEPARTMENT
Date: 09/30/13



CHEMICAL WASTE MANAGEMENT OF THE NW

17629 Cedar Springs Lane
Arlington, OR 97812
(541) 454-2643
(541) 454-3279 Fax

PORT OF TACOMA
WAD001882984
3400 TAYLOR WAY
TACOMA WA 98421

CERTIFICATE OF DISPOSAL

Chemical Waste Management of the Northwest, Inc., ORD089452353, has received the following waste material:

GENERATOR:	PORT OF TACOMA
MANIFEST #:	011880803JJK
CWM TRACKING ID:	42850201
PROFILE #:	OR321468
LINE ITEM:	9b.1
QUANTITY:	1 DT
RECEIVED DATE:	09/24/13
DISPOSAL PROCESS(ES):	LANDFILL
FINAL DISPOSAL LOCATION:	LANDFILL 13
DISPOSAL DATE:	09/24/13

I certify, on behalf of the above listed treatment facility, that to the best of my knowledge, the above-described waste material was managed in compliance with all applicable laws, regulations, permits and licenses on the date listed above.

Bobbi Jo Galvin

CWMNW RECORDS DEPARTMENT

Date: 09/30/13



CHEMICAL WASTE MANAGEMENT OF THE NW

17629 Cedar Springs Lane
Arlington, OR 97812
(541) 454-2643
(541) 454-3279 Fax

PORT OF TACOMA
WAD001882984
3400 TAYLOR WAY
TACOMA WA 98421

CERTIFICATE OF DISPOSAL

Chemical Waste Management of the Northwest, Inc., ORD089452353, has received the following waste material:

GENERATOR:	PORT OF TACOMA
MANIFEST #:	011880806JJK
CWM TRACKING ID:	42850101
PROFILE #:	OR321468
LINE ITEM:	9b.1
QUANTITY:	1 DT
RECEIVED DATE:	09/24/13
DISPOSAL PROCESS(ES):	LANDFILL
FINAL DISPOSAL LOCATION:	LANDFILL 13
DISPOSAL DATE:	09/24/13

I certify, on behalf of the above listed treatment facility, that to the best of my knowledge, the above-described waste material was managed in compliance with all applicable laws, regulations, permits and licenses on the date listed above.

Bobbi Jo Galvin

CWMNW RECORDS DEPARTMENT

Date: 09/30/13





CHEMICAL WASTE MANAGEMENT OF THE NW

17629 Cedar Springs Lane
Arlington, OR 97812
(541) 454-2643
(541) 454-3279 Fax

PORT OF TACOMA
WAD001882984
3400 TAYLOR WAY
TACOMA WA 98421

CERTIFICATE OF DISPOSAL

Chemical Waste Management of the Northwest, Inc., ORD089452353, has received the following waste material:

GENERATOR: PORT OF TACOMA
MANIFEST #: 011880999JJK
CWM TRACKING ID: 42858801
PROFILE #: OR321468
LINE ITEM: 9b.1
QUANTITY: 1 DT
RECEIVED DATE: 09/25/13

DISPOSAL PROCESS(ES): LANDFILL
FINAL DISPOSAL LOCATION: LANDFILL 13
DISPOSAL DATE: 09/25/13

I certify, on behalf of the above listed treatment facility, that to the best of my knowledge, the above-described waste material was managed in compliance with all applicable laws, regulations, permits and licenses on the date listed above.

CWMNW RECORDS DEPARTMENT

Date: 10/04/13



CHEMICAL WASTE MANAGEMENT OF THE NW

17629 Cedar Springs Lane
Arlington, OR 97812
(541) 454-2643
(541) 454-3279 Fax

PORT OF TACOMA
WAD001882984
3400 TAYLOR WAY
TACOMA WA 98421

CERTIFICATE OF DISPOSAL

Chemical Waste Management of the Northwest, Inc., ORD089452353, has received the following waste material:

GENERATOR:	PORT OF TACOMA
MANIFEST #:	010585499JJK
CWM TRACKING ID:	42860001
PROFILE #:	OR321468
LINE ITEM:	9b.1
QUANTITY:	1 DT
RECEIVED DATE:	09/25/13
DISPOSAL PROCESS(ES):	LANDFILL
FINAL DISPOSAL LOCATION:	LANDFILL 13
DISPOSAL DATE:	09/25/13

I certify, on behalf of the above listed treatment facility, that to the best of my knowledge, the above-described waste material was managed in compliance with all applicable laws, regulations, permits and licenses on the date listed above.

Bobbi Galvin

CWMNW RECORDS DEPARTMENT

Date: 10/01/13



CHEMICAL WASTE MANAGEMENT OF THE NW

17629 Cedar Springs Lane
Arlington, OR 97812
(541) 454-2643
(541) 454-3279 Fax

PORT OF TACOMA
WAD001882984
3400 TAYLOR WAY
TACOMA WA 98421

CERTIFICATE OF DISPOSAL

Chemical Waste Management of the Northwest, Inc., ORD089452353, has received the following waste material:

GENERATOR:	PORT OF TACOMA
MANIFEST #:	011880969JJK
CWM TRACKING ID:	42859901
PROFILE #:	OR321468
LINE ITEM:	9b.1
QUANTITY:	1 DT
RECEIVED DATE:	09/25/13
DISPOSAL PROCESS(ES):	LANDFILL
FINAL DISPOSAL LOCATION:	LANDFILL 13
DISPOSAL DATE:	09/25/13

I certify, on behalf of the above listed treatment facility, that to the best of my knowledge, the above-described waste material was managed in compliance with all applicable laws, regulations, permits and licenses on the date listed above.

Bobbi Jo Galvin

CWMNW RECORDS DEPARTMENT
Date: 10/01/13



CHEMICAL WASTE MANAGEMENT OF THE NW

17629 Cedar Springs Lane
Arlington, OR 97812
(541) 454-2643
(541) 454-3279 Fax

PORT OF TACOMA
WAD001882984
3400 TAYLOR WAY
TACOMA WA 98421

CERTIFICATE OF DISPOSAL

Chemical Waste Management of the Northwest, Inc., ORD089452353, has received the following waste material:

GENERATOR: PORT OF TACOMA
MANIFEST #: 010585498JJK
CWM TRACKING ID: 42859701
PROFILE #: OR321468
LINE ITEM: 9b.1
QUANTITY: 1 DT
RECEIVED DATE: 09/25/13

DISPOSAL PROCESS(ES): LANDFILL
FINAL DISPOSAL LOCATION: LANDFILL 13
DISPOSAL DATE: 09/25/13

I certify, on behalf of the above listed treatment facility, that to the best of my knowledge, the above-described waste material was managed in compliance with all applicable laws, regulations, permits and licenses on the date listed above.

CWMNW RECORDS DEPARTMENT

Date: 10/01/13



CHEMICAL WASTE MANAGEMENT OF THE NW

17629 Cedar Springs Lane
Arlington, OR 97812
(541) 454-2643
(541) 454-3279 Fax

PORT OF TACOMA
WAD001882984
3400 TAYLOR WAY
TACOMA WA 98421

CERTIFICATE OF DISPOSAL

Chemical Waste Management of the Northwest, Inc., ORD089452353, has received the following waste material:

GENERATOR: PORT OF TACOMA
MANIFEST #: 011880970JJK
CWM TRACKING ID: 42859601
PROFILE #: OR321468
LINE ITEM: 9b.1
QUANTITY: 1 DT
RECEIVED DATE: 09/25/13

DISPOSAL PROCESS(ES): LANDFILL
FINAL DISPOSAL LOCATION: LANDFILL 13
DISPOSAL DATE: 09/25/13

I certify, on behalf of the above listed treatment facility, that to the best of my knowledge, the above-described waste material was managed in compliance with all applicable laws, regulations, permits and licenses on the date listed above.

Robbi Jo Gradwin

CWMNW RECORDS DEPARTMENT

Date: 10/01/13



CHEMICAL WASTE MANAGEMENT OF THE NW

17629 Cedar Springs Lane
Arlington, OR 97812
(541) 454-2643
(541) 454-3279 Fax

PORT OF TACOMA
WAD001882984
3400 TAYLOR WAY
TACOMA WA 98421

CERTIFICATE OF DISPOSAL

Chemical Waste Management of the Northwest, Inc., ORD089452353, has received the following waste material:

GENERATOR:	PORT OF TACOMA
MANIFEST #:	011880971JJK
CWM TRACKING ID:	42859501
PROFILE #:	OR321468
LINE ITEM:	9b.1
QUANTITY:	1 DT
RECEIVED DATE:	09/25/13
DISPOSAL PROCESS(ES):	LANDFILL
FINAL DISPOSAL LOCATION:	LANDFILL 13
DISPOSAL DATE:	09/25/13

I certify, on behalf of the above listed treatment facility, that to the best of my knowledge, the above-described waste material was managed in compliance with all applicable laws, regulations, permits and licenses on the date listed above.

Bobbi Jo Galun _____

CWMNW RECORDS DEPARTMENT

Date: 10/01/13



CHEMICAL WASTE MANAGEMENT OF THE NW

17629 Cedar Springs Lane
Arlington, OR 97812
(541) 454-2643
(541) 454-3279 Fax

PORT OF TACOMA
WAD001882984
3400 TAYLOR WAY
TACOMA WA 98421

CERTIFICATE OF DISPOSAL

Chemical Waste Management of the Northwest, Inc., ORD089452353, has received the following waste material:

GENERATOR:	PORT OF TACOMA
MANIFEST #:	011380972JJK
CWM TRACKING ID:	42859401
PROFILE #:	OR321468
LINE ITEM:	9b.1
QUANTITY:	1 DT
RECEIVED DATE:	09/25/13
DISPOSAL PROCESS(ES):	LANDFILL
FINAL DISPOSAL LOCATION:	LANDFILL 13
DISPOSAL DATE:	09/25/13

I certify, on behalf of the above listed treatment facility, that to the best of my knowledge, the above-described waste material was managed in compliance with all applicable laws, regulations, permits and licenses on the date listed above.



CWMNW RECORDS DEPARTMENT

Date: 10/01/13



CHEMICAL WASTE MANAGEMENT OF THE NW

17629 Cedar Springs Lane
Arlington, OR 97812
(541) 454-2643
(541) 454-3279 Fax

PORT OF TACOMA
WAD001882984
3400 TAYLOR WAY
TACOMA WA 98421

CERTIFICATE OF DISPOSAL

Chemical Waste Management of the Northwest, Inc., ORD089452353, has received the following waste material:

GENERATOR:	PORT OF TACOMA
MANIFEST #:	010585500JJK
CWM TRACKING ID:	42859301
PROFILE #:	OR321468
LINE ITEM:	9b.1
QUANTITY:	1 DT
RECEIVED DATE:	09/25/13
DISPOSAL PROCESS(ES):	LANDFILL
FINAL DISPOSAL LOCATION:	LANDFILL 13
DISPOSAL DATE:	09/25/13

I certify, on behalf of the above listed treatment facility, that to the best of my knowledge, the above-described waste material was managed in compliance with all applicable laws, regulations, permits and licenses on the date listed above.

Bobbi Jo Galvin

CWMNW RECORDS DEPARTMENT

Date: 10/01/13



CHEMICAL WASTE MANAGEMENT OF THE NW

17629 Cedar Springs Lane
Arlington, OR 97812
(541) 454-2643
(541) 454-3279 Fax

PORT OF TACOMA
WAD001882984
3400 TAYLOR WAY
TACOMA WA 98421

CERTIFICATE OF DISPOSAL

Chemical Waste Management of the Northwest, Inc., ORD089452353, has received the following waste material:

GENERATOR:	PORT OF TACOMA
MANIFEST #:	011880992JJK
CWM TRACKING ID:	42859101
PROFILE #:	OR321468
LINE ITEM:	9b.1
QUANTITY:	1 DT
RECEIVED DATE:	09/25/13
DISPOSAL PROCESS(ES):	LANDFILL
FINAL DISPOSAL LOCATION:	LANDFILL 13
DISPOSAL DATE:	09/25/13

I certify, on behalf of the above listed treatment facility, that to the best of my knowledge, the above-described waste material was managed in compliance with all applicable laws, regulations, permits and licenses on the date listed above.

Bobbi Jo Galvin

CWMNW RECORDS DEPARTMENT

Date: 10/01/13





CHEMICAL WASTE MANAGEMENT OF THE NW

17629 Cedar Springs Lane
Arlington, OR 97812
(541) 454-2643
(541) 454-3279 Fax

PORT OF TACOMA
WAD001882984
3400 TAYLOR WAY
TACOMA WA 98421

↓
CERTIFICATE OF DISPOSAL

Chemical Waste Management of the Northwest, Inc., ORD089452353, has received the following waste material:

GENERATOR:	PORT OF TACOMA
MANIFEST #:	011880973JJK
CWM TRACKING ID:	42858601
PROFILE #:	OR321468
LINE ITEM:	9b.1
QUANTITY:	1 DT
RECEIVED DATE:	09/25/13
DISPOSAL PROCESS(ES):	LANDFILL
FINAL DISPOSAL LOCATION:	LANDFILL 13
DISPOSAL DATE:	09/25/13

I certify, on behalf of the above listed treatment facility, that to the best of my knowledge, the above-described waste material was managed in compliance with all applicable laws, regulations, permits and licenses on the date listed above.



CWMNW RECORDS DEPARTMENT
Date: 10/01/13



CHEMICAL WASTE MANAGEMENT OF THE NW

17629 Cedar Springs Lane
Arlington, OR 97812
(541) 454-2643
(541) 454-3279 Fax

PORT OF TACOMA
WAD001882984
3400 TAYLOR WAY
TACOMA WA 98421

CERTIFICATE OF DISPOSAL

Chemical Waste Management of the Northwest, Inc., ORD089452353, has received the following waste material:

GENERATOR: PORT OF TACOMA
MANIFEST #: 011880995JJK
CWM TRACKING ID: 42858401
PROFILE #: OR321468
LINE ITEM: 9b.1
QUANTITY: 1 DT
RECEIVED DATE: 09/25/13

DISPOSAL PROCESS(ES): LANDFILL
FINAL DISPOSAL LOCATION: LANDFILL 13
DISPOSAL DATE: 09/25/13

I certify, on behalf of the above listed treatment facility, that to the best of my knowledge, the above-described waste material was managed in compliance with all applicable laws, regulations, permits and licenses on the date listed above.

Bobbi Jobalvin

CWMNW RECORDS DEPARTMENT

Date: 10/01/13



CHEMICAL WASTE MANAGEMENT OF THE NW

17629 Cedar Springs Lane
Arlington, OR 97812
(541) 454-2643
(541) 454-3279 Fax

PORT OF TACOMA
WAD001882984
3400 TAYLOR WAY
TACOMA WA 98421

CERTIFICATE OF DISPOSAL

Chemical Waste Management of the Northwest, Inc., ORD089452353, has received the following waste material:

GENERATOR:	PORT OF TACOMA
MANIFEST #:	011880996JJK
CWM TRACKING ID:	42858201
PROFILE #:	OR321468
LINE ITEM:	9b.1
QUANTITY:	1 DT
RECEIVED DATE:	09/25/13
DISPOSAL PROCESS(ES):	LANDFILL
FINAL DISPOSAL LOCATION:	LANDFILL 13
DISPOSAL DATE:	09/25/13

I certify, on behalf of the above listed treatment facility, that to the best of my knowledge, the above-described waste material was managed in compliance with all applicable laws, regulations, permits and licenses on the date listed above.

Bobbi Jo Galvin

CWMNW RECORDS DEPARTMENT

Date: 10/01/13



CHEMICAL WASTE MANAGEMENT OF THE NW

17629 Cedar Springs Lane
Arlington, OR 97812
(541) 454-2643
(541) 454-3279 Fax

PORT OF TACOMA
WAD001882984
3400 TAYLOR WAY
TACOMA WA 98421

CERTIFICATE OF DISPOSAL

Chemical Waste Management of the Northwest, Inc., ORD089452353, has received the following waste material:

GENERATOR: PORT OF TACOMA
MANIFEST #: 011880993JJK
CWM TRACKING ID: 42858101
PROFILE #: OR321468
LINE ITEM: 9b.1
QUANTITY: 1 DT
RECEIVED DATE: 09/25/13

DISPOSAL PROCESS(ES): LANDFILL
FINAL DISPOSAL LOCATION: LANDFILL 13
DISPOSAL DATE: 09/25/13

I certify, on behalf of the above listed treatment facility, that to the best of my knowledge, the above-described waste material was managed in compliance with all applicable laws, regulations, permits and licenses on the date listed above.

Bobbi Jo Galvin

CWMNW RECORDS DEPARTMENT

Date: 10/01/13



CHEMICAL WASTE MANAGEMENT OF THE NW

17629 Cedar Springs Lane
Arlington, OR 97812
(541) 454-2643
(541) 454-3279 Fax

PORT OF TACOMA
WAD001882984
3400 TAYLOR WAY
TACOMA WA 98421

CERTIFICATE OF DISPOSAL

Chemical Waste Management of the Northwest, Inc., ORD089452353, has received the following waste material:

GENERATOR:	PORT OF TACOMA
MANIFEST #:	011880983JJK
CWM TRACKING ID:	42858001
PROFILE #:	OR321468
LINE ITEM:	9b.1
QUANTITY:	1 DT
RECEIVED DATE:	09/25/13
DISPOSAL PROCESS(ES):	LANDFILL
FINAL DISPOSAL LOCATION:	LANDFILL 13
DISPOSAL DATE:	09/25/13

I certify, on behalf of the above listed treatment facility, that to the best of my knowledge, the above-described waste material was managed in compliance with all applicable laws, regulations, permits and licenses on the date listed above.

Bobbi Jo Galvin

CWMNW RECORDS DEPARTMENT

Date: 10/01/13



CHEMICAL WASTE MANAGEMENT OF THE NW

17629 Cedar Springs Lane
Arlington, OR 97812
(541) 454-2643
(541) 454-3279 Fax

PORT OF TACOMA
WAD001882984
3400 TAYLOR WAY
TACOMA WA 98421

CERTIFICATE OF DISPOSAL

Chemical Waste Management of the Northwest, Inc., ORD089452353, has received the following waste material:

GENERATOR: PORT OF TACOMA
MANIFEST #: 011880987JJK
CWM TRACKING ID: 42857901
PROFILE #: OR321468
LINE ITEM: 9b.1
QUANTITY: 1 DT
RECEIVED DATE: 09/25/13

DISPOSAL PROCESS(ES): LANDFILL
FINAL DISPOSAL LOCATION: LANDFILL 13
DISPOSAL DATE: 09/25/13

I certify, on behalf of the above listed treatment facility, that to the best of my knowledge, the above-described waste material was managed in compliance with all applicable laws, regulations, permits and licenses on the date listed above.

Bobbi Jo Galvin

CWMNW RECORDS DEPARTMENT

Date: 10/01/13



CHEMICAL WASTE MANAGEMENT OF THE NW

17629 Cedar Springs Lane
Arlington, OR 97812
(541) 454-2643
(541) 454-3279 Fax

1

PORT OF TACOMA
WAD001882984
3400 TAYLOR WAY
TACOMA WA 98421

CERTIFICATE OF DISPOSAL

Chemical Waste Management of the Northwest, Inc., ORD089452353, has received the following waste material:

GENERATOR: PORT OF TACOMA
MANIFEST #: 011881000JJK
CWM TRACKING ID: 42857801
PROFILE #: OR321468
LINE ITEM: 9b.1
QUANTITY: 1 DT
RECEIVED DATE: 09/25/13

DISPOSAL PROCESS(ES): LANDFILL
FINAL DISPOSAL LOCATION: LANDFILL 13
DISPOSAL DATE: 09/25/13

I certify, on behalf of the above listed treatment facility, that to the best of my knowledge, the above-described waste material was managed in compliance with all applicable laws, regulations, permits and licenses on the date listed above.

Bobbi Jo Galun

CWMNW RECORDS DEPARTMENT

Date: 10/01/13

1





CHEMICAL WASTE MANAGEMENT OF THE NW

17629 Cedar Springs Lane
Arlington, OR 97812
(541) 454-2643
(541) 454-3279 Fax

PORT OF TACOMA
WAD001882984
3400 TAYLOR WAY
TACOMA WA 98421

CERTIFICATE OF DISPOSAL

Chemical Waste Management of the Northwest, Inc., ORD089452353, has received the following waste material:

GENERATOR: PORT OF TACOMA
MANIFEST #: 011880984JJK
CWM TRACKING ID: 42857701
PROFILE #: OR321468
LINE ITEM: 9b.1
QUANTITY: 1 DT
RECEIVED DATE: 09/25/13

DISPOSAL PROCESS(ES): LANDFILL
FINAL DISPOSAL LOCATION: LANDFILL 13
DISPOSAL DATE: 09/25/13

I certify, on behalf of the above listed treatment facility, that to the best of my knowledge, the above-described waste material was managed in compliance with all applicable laws, regulations, permits and licenses on the date listed above.

Bobbi Jobalvin

CWMNW RECORDS DEPARTMENT

Date: 10/01/13



CHEMICAL WASTE MANAGEMENT OF THE NW

17629 Cedar Springs Lane
Arlington, OR 97812
(541) 454-2643
(541) 454-3279 Fax

PORT OF TACOMA
WAD001882984
3400 TAYLOR WAY
TACOMA WA 98421

CERTIFICATE OF DISPOSAL

Chemical Waste Management of the Northwest, Inc., ORD089452353, has received the following waste material:

GENERATOR: PORT OF TACOMA
MANIFEST #: 011880982JJK
CWM TRACKING ID: 42857601
PROFILE #: OR321468
LINE ITEM: 9b.1
QUANTITY: 1 D
RECEIVED DATE: 09/25/13

DISPOSAL PROCESS(ES): LANDFILL
FINAL DISPOSAL LOCATION: LANDFILL 13
DISPOSAL DATE: 09/25/13

I certify, on behalf of the above listed treatment facility, that to the best of my knowledge, the above-described waste material was managed in compliance with all applicable laws, regulations, permits and licenses on the date listed above.

Bobbi Jo Galvin

CWMNW RECORDS DEPARTMENT

Date: 10/01/13



CHEMICAL WASTE MANAGEMENT OF THE NW

17629 Cedar Springs Lane
Arlington, OR 97812
(541) 454-2643
(541) 454-3279 Fax

PORT OF TACOMA
WAD001882984
3400 TAYLOR WAY
TACOMA WA 98421

CERTIFICATE OF DISPOSAL

Chemical Waste Management of the Northwest, Inc., ORD089452353, has received the following waste material:

GENERATOR: PORT OF TACOMA
MANIFEST #: 011880998JJK
CWM TRACKING ID: 42857501
PROFILE #: OR321468
LINE ITEM: 9b.1
QUANTITY: 1 DT
RECEIVED DATE: 09/25/13

DISPOSAL PROCESS(ES): LANDFILL
FINAL DISPOSAL LOCATION: LANDFILL 13
DISPOSAL DATE: 09/25/13

I certify, on behalf of the above listed treatment facility, that to the best of my knowledge, the above-described waste material was managed in compliance with all applicable laws, regulations, permits and licenses on the date listed above.

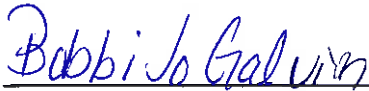

CWMNW RECORDS DEPARTMENT

Date: 10/01/13



CHEMICAL WASTE MANAGEMENT OF THE NW

17629 Cedar Springs Lane
Arlington, OR 97812
(541) 454-2643
(541) 454-3279 Fax

PORT OF TACOMA
WAD001882984
3400 TAYLOR WAY
TACOMA WA 98421

CERTIFICATE OF DISPOSAL

Chemical Waste Management of the Northwest, Inc., ORD089452353, has received the following waste material:

GENERATOR:	PORT OF TACOMA	
MANIFEST #:	011880986JJK	
CWM TRACKING ID:	42857401	
PROFILE #:	OR321468	
LINE ITEM:	9b.1	
QUANTITY:	1 DT	
RECEIVED DATE:	09/25/13	
DISPOSAL PROCESS(ES):	LANDFILL	
FINAL DISPOSAL LOCATION:	LANDFILL	13
DISPOSAL DATE:	09/25/13	

I certify, on behalf of the above listed treatment facility, that to the best of my knowledge, the above-described waste material was managed in compliance with all applicable laws, regulations, permits and licenses on the date listed above.

Robbin A. Galvin

CWMNW RECORDS DEPARTMENT

Date: 10/01/13



CHEMICAL WASTE MANAGEMENT OF THE NW

17629 Cedar Springs Lane
Arlington, OR 97812
(541) 454-2643
(541) 454-3279 Fax

PORT OF TACOMA
WAD001882984
3400 TAYLOR WAY
TACOMA WA 98421

CERTIFICATE OF DISPOSAL

Chemical Waste Management of the Northwest, Inc., ORD089452353, has received the following waste material:

GENERATOR: PORT OF TACOMA
MANIFEST #: 011880991JJK
CWM TRACKING ID: 42857101
PROFILE #: OR321468
LINE ITEM: 9b.1
QUANTITY: 1 DT
RECEIVED DATE: 09/25/13

DISPOSAL PROCESS(ES): LANDFILL
FINAL DISPOSAL LOCATION: LANDFILL 13
DISPOSAL DATE: 09/25/13

I certify, on behalf of the above listed treatment facility, that to the best of my knowledge, the above-described waste material was managed in compliance with all applicable laws, regulations, permits and licenses on the date listed above.

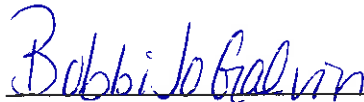

CWMNW RECORDS DEPARTMENT

Date: 10/01/13



CHEMICAL WASTE MANAGEMENT OF THE NW

17629 Cedar Springs Lane
Arlington, OR 97812
(541) 454-2643
(541) 454-3279 Fax

PORT OF TACOMA
WAD001882984
3400 TAYLOR WAY
TACOMA WA 98421

CERTIFICATE OF DISPOSAL

Chemical Waste Management of the Northwest, Inc., ORD089452353, has received the following waste material:

GENERATOR:	PORT OF TACOMA
MANIFEST #:	011880988JJK
CWM TRACKING ID:	42856901
PROFILE #:	OR321468
LINE ITEM:	9b.1
QUANTITY:	1 DT
RECEIVED DATE:	09/25/13
DISPOSAL PROCESS(ES):	LANDFILL
FINAL DISPOSAL LOCATION:	LANDFILL 13
DISPOSAL DATE:	09/25/13

I certify, on behalf of the above listed treatment facility, that to the best of my knowledge, the above-described waste material was managed in compliance with all applicable laws, regulations, permits and licenses on the date listed above.

Bobbi Galvin

CWMNW RECORDS DEPARTMENT

Date: 10/01/13



CHEMICAL WASTE MANAGEMENT OF THE NW

17629 Cedar Springs Lane
Arlington, OR 97812
(541) 454-2643
(541) 454-3279 Fax

PORT OF TACOMA
WAD001882984
3400 TAYLOR WAY
TACOMA WA 98421

CERTIFICATE OF DISPOSAL

Chemical Waste Management of the Northwest, Inc., ORD089452353, has received the following waste material:

GENERATOR:	PORT OF TACOMA
MANIFEST #:	011880989JJK
CWM TRACKING ID:	42857001
PROFILE #:	OR321468
LINE ITEM:	9b.1
QUANTITY:	1 DT
RECEIVED DATE:	09/25/13
DISPOSAL PROCESS(ES):	LANDFILL
FINAL DISPOSAL LOCATION:	LANDFILL 13
DISPOSAL DATE:	09/25/13

I certify, on behalf of the above listed treatment facility, that to the best of my knowledge, the above-described waste material was managed in compliance with all applicable laws, regulations, permits and licenses on the date listed above.

Bobbi Jo Galvin

CWMNW RECORDS DEPARTMENT
Date: 10/01/13



CHEMICAL WASTE MANAGEMENT OF THE NW

17629 Cedar Springs Lane
Arlington, OR 97812
(541) 454-2643
(541) 454-3279 Fax

PORT OF TACOMA
WAD001882984
3400 TAYLOR WAY
TACOMA WA 98421

CERTIFICATE OF DISPOSAL

Chemical Waste Management of the Northwest, Inc., ORD089452353, has received the following waste material:

GENERATOR:	PORT OF TACOMA
MANIFEST #:	011880990JJK
CWM TRACKING ID:	42856501
PROFILE #:	OR321468
LINE ITEM:	9b.1
QUANTITY:	1 DT
RECEIVED DATE:	09/25/13
DISPOSAL PROCESS(ES):	LANDFILL
FINAL DISPOSAL LOCATION:	LANDFILL 13
DISPOSAL DATE:	09/25/13

I certify, on behalf of the above listed treatment facility, that to the best of my knowledge, the above-described waste material was managed in compliance with all applicable laws, regulations, permits and licenses on the date listed above.

Bobbi Galum

CWMNW RECORDS DEPARTMENT

Date: 10/01/13



CHEMICAL WASTE MANAGEMENT OF THE NW

17629 Cedar Springs Lane
Arlington, OR 97812
(541) 454-2643
(541) 454-3279 Fax

PORT OF TACOMA
WAD001882984
3400 TAYLOR WAY
TACOMA WA 98421

CERTIFICATE OF DISPOSAL

Chemical Waste Management of the Northwest, Inc., ORD089452353, has received the following waste material:

GENERATOR:	PORT OF TACOMA
MANIFEST #:	011880985JJK
CWM TRACKING ID:	42856401
PROFILE #:	OR321468
LINE ITEM:	9b.1
QUANTITY:	1 DT
RECEIVED DATE:	09/25/13
DISPOSAL PROCESS(ES):	LANDFILL
FINAL DISPOSAL LOCATION:	LANDFILL 13
DISPOSAL DATE:	09/25/13

I certify, on behalf of the above listed treatment facility, that to the best of my knowledge, the above-described waste material was managed in compliance with all applicable laws, regulations, permits and licenses on the date listed above.

Bobbi Kovalin

CWMNW RECORDS DEPARTMENT

Date: 10/01/13



CHEMICAL WASTE MANAGEMENT OF THE NW

17629 Cedar Springs Lane
Arlington, OR 97812
(541) 454-2643
(541) 454-3279 Fax

PORT OF TACOMA
WAD001882984
3400 TAYLOR WAY
TACOMA WA 98421

CERTIFICATE OF DISPOSAL

Chemical Waste Management of the Northwest, Inc., ORD089452353, has received the following waste material:

GENERATOR:	PORT OF TACOMA
MANIFEST #:	011880980JJK
CWM TRACKING ID:	42854701
PROFILE #:	OR321468
LINE ITEM:	9b.1
QUANTITY:	1 DT
RECEIVED DATE:	09/25/13
DISPOSAL PROCESS(ES):	LANDFILL
FINAL DISPOSAL LOCATION:	LANDFILL 13
DISPOSAL DATE:	09/25/13

I certify, on behalf of the above listed treatment facility, that to the best of my knowledge, the above-described waste material was managed in compliance with all applicable laws, regulations, permits and licenses on the date listed above.

Robbio Galvin

CWMNW RECORDS DEPARTMENT

Date: 10/01/13



CHEMICAL WASTE MANAGEMENT OF THE NW

17629 Cedar Springs Lane
Arlington, OR 97812
(541) 454-2643
(541) 454-3279 Fax

PORT OF TACOMA
WAD001882984
3400 TAYLOR WAY
TACOMA WA 98421

CERTIFICATE OF DISPOSAL

Chemical Waste Management of the Northwest, Inc., ORD089452353, has received the following waste material:

GENERATOR:	PORT OF TACOMA
MANIFEST #:	011880979JJK
CWM TRACKING ID:	42854601
PROFILE #:	OR321468
LINE ITEM:	9b.1
QUANTITY:	1 DT
RECEIVED DATE:	09/25/13
DISPOSAL PROCESS(ES):	LANDFILL
FINAL DISPOSAL LOCATION:	LANDFILL 13
DISPOSAL DATE:	09/25/13

I certify, on behalf of the above listed treatment facility, that to the best of my knowledge, the above-described waste material was managed in compliance with all applicable laws, regulations, permits and licenses on the date listed above.

Bobbi Jobalvin

CWMNW RECORDS DEPARTMENT

Date: 10/01/13



CHEMICAL WASTE MANAGEMENT OF THE NW
17629 Cedar Springs Lane
Arlington, OR 97812
(541) 454-2643
(541) 454-3279 Fax

PORT OF TACOMA
WAD001882984
3400 TAYLOR WAY
TACOMA WA 98421

CERTIFICATE OF DISPOSAL

Chemical Waste Management of the Northwest, Inc., ORD089452353, has received the following waste material:

GENERATOR: PORT OF TACOMA
MANIFEST #: 010585454JJK
CWM TRACKING ID: 42867001
PROFILE #: OR321468
LINE ITEM: 9b.1
QUANTITY: 1 DT
RECEIVED DATE: 09/26/13

DISPOSAL PROCESS(ES): LANDFILL
FINAL DISPOSAL LOCATION: LANDFILL 14
DISPOSAL DATE: 09/26/13

I certify, on behalf of the above listed treatment facility, that to the best of my knowledge, the above-described waste material was managed in compliance with all applicable laws, regulations, permits and licenses on the date listed above.



CWMNW RECORDS DEPARTMENT

Date: 10/04/13



CHEMICAL WASTE MANAGEMENT OF THE NW

17629 Cedar Springs Lane
Arlington, OR 97812
(541) 454-2643
(541) 454-3279 Fax

PORT OF TACOMA
WAD001882984
3400 TAYLOR WAY
TACOMA WA 98421

1

CERTIFICATE OF DISPOSAL

Chemical Waste Management of the Northwest, Inc., ORD089452353, has received the following waste material:

GENERATOR: PORT OF TACOMA
MANIFEST #: 010585470JJK
CWM TRACKING ID: 42866801
PROFILE #: OR321468
LINE ITEM: 9b.1
QUANTITY: 1 DT
RECEIVED DATE: 09/26/13

DISPOSAL PROCESS(ES): LANDFILL
FINAL DISPOSAL LOCATION: LANDFILL 14
DISPOSAL DATE: 09/26/13

I certify, on behalf of the above listed treatment facility, that to the best of my knowledge, the above-described waste material was managed in compliance with all applicable laws, regulations, permits and licenses on the date listed above.



CWMNW RECORDS DEPARTMENT

Date: 10/04/13



CHEMICAL WASTE MANAGEMENT OF THE NW

17629 Cedar Springs Lane
Arlington, OR 97812
(541) 454-2643
(541) 454-3279 Fax

PORT OF TACOMA
WAD001882984
3400 TAYLOR WAY
TACOMA WA 98421

CERTIFICATE OF DISPOSAL

Chemical Waste Management of the Northwest, Inc., ORD089452353, has received the following waste material:

GENERATOR:	PORT OF TACOMA
MANIFEST #:	010585475JJK
CWM TRACKING ID:	42865801
PROFILE #:	OR321468
LINE ITEM:	9b.1
QUANTITY:	1 DT
RECEIVED DATE:	09/26/13
DISPOSAL PROCESS(ES):	LANDFILL
FINAL DISPOSAL LOCATION:	LANDFILL 14
DISPOSAL DATE:	09/26/13

I certify, on behalf of the above listed treatment facility, that to the best of my knowledge, the above-described waste material was managed in compliance with all applicable laws, regulations, permits and licenses on the date listed above.

CWMNW RECORDS DEPARTMENT

Date: 10/04/13



CHEMICAL WASTE MANAGEMENT OF THE NW

17629 Cedar Springs Lane
Arlington, OR 97812
(541) 454-2643
(541) 454-3279 Fax

PORT OF TACOMA
WAD001882984
3400 TAYLOR WAY
TACOMA WA 98421

CERTIFICATE OF DISPOSAL

Chemical Waste Management of the Northwest, Inc., ORD089452353, has received the following waste material:

GENERATOR:	PORT OF TACOMA
MANIFEST #:	010585473JJK
CWM TRACKING ID:	42866401
PROFILE #:	OR321468
LINE ITEM:	9b.1
QUANTITY:	1 DT
RECEIVED DATE:	09/26/13
DISPOSAL PROCESS(ES):	LANDFILL
FINAL DISPOSAL LOCATION:	LANDFILL 13
DISPOSAL DATE:	09/26/13

I certify, on behalf of the above listed treatment facility, that to the best of my knowledge, the above-described waste material was managed in compliance with all applicable laws, regulations, permits and licenses on the date listed above.



CWMNW RECORDS DEPARTMENT

Date: 10/01/13



CHEMICAL WASTE MANAGEMENT OF THE NW

17629 Cedar Springs Lane
Arlington, OR 97812
(541) 454-2643
(541) 454-3279 Fax

PORT OF TACOMA
WAD001882984
3400 TAYLOR WAY
TACOMA WA 98421

CERTIFICATE OF DISPOSAL

Chemical Waste Management of the Northwest, Inc., ORD089452353, has received the following waste material:

GENERATOR: PORT OF TACOMA
MANIFEST #: 010585474JJK
CWM TRACKING ID: 42865701
PROFILE #: OR321468
LINE ITEM: 9b.1
QUANTITY: 1 DT
RECEIVED DATE: 09/26/13

DISPOSAL PROCESS(ES): LANDFILL
FINAL DISPOSAL LOCATION: LANDFILL 13
DISPOSAL DATE: 09/26/13

I certify, on behalf of the above listed treatment facility, that to the best of my knowledge, the above-described waste material was managed in compliance with all applicable laws, regulations, permits and licenses on the date listed above.

Robb Jo Galvin

CWMNW RECORDS DEPARTMENT

Date: 10/01/13



CHEMICAL WASTE MANAGEMENT OF THE NW

17629 Cedar Springs Lane
Arlington, OR 97812
(541) 454-2643
(541) 454-3279 Fax

PORT OF TACOMA
WAD001882984
3400 TAYLOR WAY
TACOMA WA 98421

CERTIFICATE OF DISPOSAL

Chemical Waste Management of the Northwest, Inc., ORD089452353, has received the following waste material:

GENERATOR:	PORT OF TACOMA
MANIFEST #:	010585476JJK
CWM TRACKING ID:	42865301
PROFILE #:	OR321468
LINE ITEM:	9b.1
QUANTITY:	1 DT
RECEIVED DATE:	09/26/13
DISPOSAL PROCESS(ES):	LANDFILL
FINAL DISPOSAL LOCATION:	LANDFILL 13
DISPOSAL DATE:	09/26/13

I certify, on behalf of the above listed treatment facility, that to the best of my knowledge, the above-described waste material was managed in compliance with all applicable laws, regulations, permits and licenses on the date listed above.



CWMNW RECORDS DEPARTMENT

Date: 10/01/13



CHEMICAL WASTE MANAGEMENT OF THE NW

17629 Cedar Springs Lane
Arlington, OR 97812
(541) 454-2643
(541) 454-3279 Fax

PORT OF TACOMA
WAD001882984
3400 TAYLOR WAY
TACOMA WA 98421

CERTIFICATE OF DISPOSAL

Chemical Waste Management of the Northwest, Inc., ORD089452353, has received the following waste material:

GENERATOR:	PORT OF TACOMA
MANIFEST #:	010585477JJK
CWM TRACKING ID:	42865201
PROFILE #:	OR321468
LINE ITEM:	9b.1
QUANTITY:	1 DT
RECEIVED DATE:	09/26/13
DISPOSAL PROCESS(ES):	LANDFILL
FINAL DISPOSAL LOCATION:	LANDFILL 13
DISPOSAL DATE:	09/26/13

I certify, on behalf of the above listed treatment facility, that to the best of my knowledge, the above-described waste material was managed in compliance with all applicable laws, regulations, permits and licenses on the date listed above.

Robbi Jo Galvin

CWMNW RECORDS DEPARTMENT

Date: 10/01/13



CHEMICAL WASTE MANAGEMENT OF THE NW

17629 Cedar Springs Lane
Arlington, OR 97812
(541) 454-2643
(541) 454-3279 Fax

PORT OF TACOMA
WAD001882984
3400 TAYLOR WAY
TACOMA WA 98421

CERTIFICATE OF DISPOSAL

Chemical Waste Management of the Northwest, Inc., ORD089452353, has received the following waste material:

GENERATOR:	PORT OF TACOMA
MANIFEST #:	010585478JJK
CWM TRACKING ID:	42865001
PROFILE #:	OR321468
LINE ITEM:	9b.1
QUANTITY:	1 DT
RECEIVED DATE:	09/26/13
DISPOSAL PROCESS(ES):	LANDFILL
FINAL DISPOSAL LOCATION:	LANDFILL 13
DISPOSAL DATE:	09/26/13

I certify, on behalf of the above listed treatment facility, that to the best of my knowledge, the above-described waste material was managed in compliance with all applicable laws, regulations, permits and licenses on the date listed above.

Debbie Grady

CWMNW RECORDS DEPARTMENT
Date:

10/01/13



CHEMICAL WASTE MANAGEMENT OF THE NW

17629 Cedar Springs Lane
Arlington, OR 97812
(541) 454-2643
(541) 454-3279 Fax

PORT OF TACOMA
WAD001882984
3400 TAYLOR WAY
TACOMA WA 98421

CERTIFICATE OF DISPOSAL

Chemical Waste Management of the Northwest, Inc., ORD089452353, has received the following waste material:

GENERATOR:	PORT OF TACOMA
MANIFEST #:	010585481JJK
CWM TRACKING ID:	42864901
PROFILE #:	OR321468
LINE ITEM:	9b.1
QUANTITY:	1 DT
RECEIVED DATE:	09/26/13
DISPOSAL PROCESS(ES):	LANDFILL
FINAL DISPOSAL LOCATION:	LANDFILL 13
DISPOSAL DATE:	09/26/13

I certify, on behalf of the above listed treatment facility, that to the best of my knowledge, the above-described waste material was managed in compliance with all applicable laws, regulations, permits and licenses on the date listed above.



CWMNW RECORDS DEPARTMENT

Date: 10/01/13



CHEMICAL WASTE MANAGEMENT OF THE NW

17629 Cedar Springs Lane
Arlington, OR 97812
(541) 454-2643
(541) 454-3279 Fax

PORT OF TACOMA
WAD001882984
3400 TAYLOR WAY
TACOMA WA 98421

CERTIFICATE OF DISPOSAL

Chemical Waste Management of the Northwest, Inc., ORD089452353, has received the following waste material:

GENERATOR:	PORT OF TACOMA
MANIFEST #:	010585483JJK
CWM TRACKING ID:	42864801
PROFILE #:	OR321468
LINE ITEM:	9b.1
QUANTITY:	1 DT
RECEIVED DATE:	09/26/13
DISPOSAL PROCESS(ES):	LANDFILL
FINAL DISPOSAL LOCATION:	LANDFILL 13
DISPOSAL DATE:	09/26/13

I certify, on behalf of the above listed treatment facility, that to the best of my knowledge, the above-described waste material was managed in compliance with all applicable laws, regulations, permits and licenses on the date listed above.

Bobbi Jobalvin

CWMNW RECORDS DEPARTMENT

Date: 10/01/13



CHEMICAL WASTE MANAGEMENT OF THE NW

17629 Cedar Springs Lane
Arlington, OR 97812
(541) 454-2643
(541) 454-3279 Fax

PORT OF TACOMA
WAD001882984
3400 TAYLOR WAY
TACOMA WA 98421

CERTIFICATE OF DISPOSAL

Chemical Waste Management of the Northwest, Inc., ORD089452353, has received the following waste material:

GENERATOR:	PORT OF TACOMA
MANIFEST #:	010585479JJK
CWM TRACKING ID:	42864701
PROFILE #:	OR321468
LINE ITEM:	9b.1
QUANTITY:	1 DT
RECEIVED DATE:	09/26/13
DISPOSAL PROCESS(ES):	LANDFILL
FINAL DISPOSAL LOCATION:	LANDFILL 13
DISPOSAL DATE:	09/26/13

I certify, on behalf of the above listed treatment facility, that to the best of my knowledge, the above-described waste material was managed in compliance with all applicable laws, regulations, permits and licenses on the date listed above.



CWMNW RECORDS DEPARTMENT

Date: 10/01/13



CHEMICAL WASTE MANAGEMENT OF THE NW

17629 Cedar Springs Lane
Arlington, OR 97812
(541) 454-2643
(541) 454-3279 Fax

PORT OF TACOMA
WAD001882984
3400 TAYLOR WAY
TACOMA WA 98421

CERTIFICATE OF DISPOSAL

Chemical Waste Management of the Northwest, Inc., ORD089452353, has received the following waste material:

GENERATOR:	PORT OF TACOMA
MANIFEST #:	010585480JJK
CWM TRACKING ID:	42864601
PROFILE #:	OR321468
LINE ITEM:	9b.1
QUANTITY:	1 DT
RECEIVED DATE:	09/26/13
DISPOSAL PROCESS(ES):	LANDFILL
FINAL DISPOSAL LOCATION:	LANDFILL 13
DISPOSAL DATE:	09/25/13

I certify, on behalf of the above listed treatment facility, that to the best of my knowledge, the above-described waste material was managed in compliance with all applicable laws, regulations, permits and licenses on the date listed above.



CWMNW RECORDS DEPARTMENT

Date: 10/01/13



CHEMICAL WASTE MANAGEMENT OF THE NW
17629 Cedar Springs Lane
Arlington, OR 97812
(541) 454-2643
(541) 454-3279 Fax

PORT OF TACOMA
WAD001882984
3400 TAYLOR WAY
TACOMA WA 98421

CERTIFICATE OF DISPOSAL

Chemical Waste Management of the Northwest, Inc., ORD089452353, has received the following waste material:

GENERATOR:	PORT OF TACOMA
MANIFEST #:	01085486JJK
CWM TRACKING ID:	42864501
PROFILE #:	OR321468
LINE ITEM:	9b.1
QUANTITY:	1 DT
RECEIVED DATE:	09/26/13
DISPOSAL PROCESS(ES):	LANDFILL
FINAL DISPOSAL LOCATION:	LANDFILL 13
DISPOSAL DATE:	09/26/13

I certify, on behalf of the above listed treatment facility, that to the best of my knowledge, the above-described waste material was managed in compliance with all applicable laws, regulations, permits and licenses on the date listed above.



CWMNW RECORDS DEPARTMENT

Date: 10/01/13





CHEMICAL WASTE MANAGEMENT OF THE NW

17629 Cedar Springs Lane
Arlington, OR 97812
(541) 454-2643
(541) 454-3279 Fax

PORT OF TACOMA
WAD001882984
3400 TAYLOR WAY
TACOMA WA 98421

CERTIFICATE OF DISPOSAL

Chemical Waste Management of the Northwest, Inc., ORD089452353, has received the following waste material:

GENERATOR:	PORT OF TACOMA
MANIFEST #:	010585487JJK
CWM TRACKING ID:	42864401
PROFILE #:	OR321468
LINE ITEM:	9b.1
QUANTITY:	1 DT
RECEIVED DATE:	09/26/13
DISPOSAL PROCESS(ES):	LANDFILL
FINAL DISPOSAL LOCATION:	LANDFILL 13
DISPOSAL DATE:	09/26/13

I certify, on behalf of the above listed treatment facility, that to the best of my knowledge, the above-described waste material was managed in compliance with all applicable laws, regulations, permits and licenses on the date listed above.

Bobbi Jobalvin

CWMNW RECORDS DEPARTMENT

Date: 10/01/13



CHEMICAL WASTE MANAGEMENT OF THE NW
17629 Cedar Springs Lane
Arlington, OR 97812
(541) 454-2643
(541) 454-3279 Fax

PORT OF TACOMA
WAD001882984
3400 TAYLOR WAY
TACOMA WA 98421

CERTIFICATE OF DISPOSAL

Chemical Waste Management of the Northwest, Inc., ORD089452353, has received the following waste material:

GENERATOR:	PORT OF TACOMA
MANIFEST #:	010585495JJK
CWM TRACKING ID:	42864301
PROFILE #:	OR321468
LINE ITEM:	9b.1
QUANTITY:	1 DT
RECEIVED DATE:	09/26/13
DISPOSAL PROCESS(ES):	LANDFILL
FINAL DISPOSAL LOCATION:	LANDFILL 13
DISPOSAL DATE:	09/26/13

I certify, on behalf of the above listed treatment facility, that to the best of my knowledge, the above-described waste material was managed in compliance with all applicable laws, regulations, permits and licenses on the date listed above.

Bobbi's Bradin

CWMNW RECORDS DEPARTMENT
Date: 10/01/13





CHEMICAL WASTE MANAGEMENT OF THE NW

17629 Cedar Springs Lane
Arlington, OR 97812
(541) 454-2643
(541) 454-3279 Fax

PORT OF TACOMA
WAD001882984
3400 TAYLOR WAY
TACOMA WA 98421

CERTIFICATE OF DISPOSAL

Chemical Waste Management of the Northwest, Inc., ORD089452353, has received the following waste material:

GENERATOR:	PORT OF TACOMA
MANIFEST #:	010585485JJK
CWM TRACKING ID:	42864101
PROFILE #:	OR321468
LINE ITEM:	9b.1
QUANTITY:	1 DT
RECEIVED DATE:	09/26/13
DISPOSAL PROCESS(ES):	LANDFILL
FINAL DISPOSAL LOCATION:	LANDFILL 13
DISPOSAL DATE:	09/26/13

I certify, on behalf of the above listed treatment facility, that to the best of my knowledge, the above-described waste material was managed in compliance with all applicable laws, regulations, permits and licenses on the date listed above.



CWMNW RECORDS DEPARTMENT

Date: 10/01/13



CHEMICAL WASTE MANAGEMENT OF THE NW

17629 Cedar Springs Lane
Arlington, OR 97812
(541) 454-2643
(541) 454-3279 Fax

PORT OF TACOMA
WAD001882984
3400 TAYLOR WAY
TACOMA WA 98421

CERTIFICATE OF DISPOSAL

Chemical Waste Management of the Northwest, Inc., ORD089452353, has received the following waste material:

GENERATOR:	PORT OF TACOMA
MANIFEST #:	010585482JJK
CWM TRACKING ID:	42863901
PROFILE #:	OR321468
LINE ITEM:	9b.1
QUANTITY:	1 DT
RECEIVED DATE:	09/26/13
DISPOSAL PROCESS(ES):	LANDFILL
FINAL DISPOSAL LOCATION:	LANDFILL 13
DISPOSAL DATE:	09/26/13

I certify, on behalf of the above listed treatment facility, that to the best of my knowledge, the above-described waste material was managed in compliance with all applicable laws, regulations, permits and licenses on the date listed above.

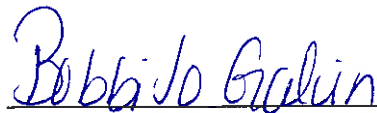

CWMNW RECORDS DEPARTMENT

Date: 10/01/13



CHEMICAL WASTE MANAGEMENT OF THE NW

17629 Cedar Springs Lane
Arlington, OR 97812
(541) 454-2643
(541) 454-3279 Fax

PORT OF TACOMA
WAD001882984
3400 TAYLOR WAY
TACOMA WA 98421

CERTIFICATE OF DISPOSAL

Chemical Waste Management of the Northwest, Inc., ORD089452353, has received the following waste material:

GENERATOR:	PORT OF TACOMA
MANIFEST #:	010585484JJK
CWM TRACKING ID:	42863801
PROFILE #:	OR321468
LINE ITEM:	9b.1
QUANTITY:	1 DT
RECEIVED DATE:	09/26/13
DISPOSAL PROCESS(ES):	LANDFILL
FINAL DISPOSAL LOCATION:	LANDFILL 13
DISPOSAL DATE:	09/26/13

I certify, on behalf of the above listed treatment facility, that to the best of my knowledge, the above-described waste material was managed in compliance with all applicable laws, regulations, permits and licenses on the date listed above.



CWMNW RECORDS DEPARTMENT

Date: 10/01/13



1

CHEMICAL WASTE MANAGEMENT OF THE NW

17629 Cedar Springs Lane
Arlington, OR 97812
(541) 454-2643
(541) 454-3279 Fax

PORT OF TACOMA
WAD001882984
3400 TAYLOR WAY
TACOMA WA 98421

CERTIFICATE OF DISPOSAL

Chemical Waste Management of the Northwest, Inc., ORD089452353, has received the following waste material:

GENERATOR: PORT OF TACOMA
MANIFEST #: 010585493JJK
CWM TRACKING ID: 42863701
PROFILE #: OR321468
LINE ITEM: 9b.1
QUANTITY: 1 DT
RECEIVED DATE: 09/26/13

DISPOSAL PROCESS(ES): LANDFILL
FINAL DISPOSAL LOCATION: LANDFILL 13
DISPOSAL DATE: 09/26/13

I certify, on behalf of the above listed treatment facility, that to the best of my knowledge, the above-described waste material was managed in compliance with all applicable laws, regulations, permits and licenses on the date listed above.

CWMNW RECORDS DEPARTMENT

Date: 10/01/13

4



CHEMICAL WASTE MANAGEMENT OF THE NW

17629 Cedar Springs Lane
Arlington, OR 97812
(541) 454-2643
(541) 454-3279 Fax

PORT OF TACOMA
WAD001882984
3400 TAYLOR WAY
TACOMA WA 98421

CERTIFICATE OF DISPOSAL

Chemical Waste Management of the Northwest, Inc., ORD089452353, has received the following waste material:

GENERATOR:	PORT OF TACOMA
MANIFEST #:	010585488JJK
CWM TRACKING ID:	42863601
PROFILE #:	OR321468
LINE ITEM:	9b.1
QUANTITY:	1 DT
RECEIVED DATE:	09/26/13
DISPOSAL PROCESS(ES):	LANDFILL
FINAL DISPOSAL LOCATION:	LANDFILL 13
DISPOSAL DATE:	09/26/13

I certify, on behalf of the above listed treatment facility, that to the best of my knowledge, the above-described waste material was managed in compliance with all applicable laws, regulations, permits and licenses on the date listed above.



CWMNW RECORDS DEPARTMENT

Date: 10/01/13



CHEMICAL WASTE MANAGEMENT OF THE NW

17629 Cedar Springs Lane
Arlington, OR 97812
(541) 454-2643
(541) 454-3279 Fax

PORT OF TACOMA
WAD001882984
3400 TAYLOR WAY
TACOMA WA 98421

CERTIFICATE OF DISPOSAL

Chemical Waste Management of the Northwest, Inc., ORD089452353, has received the following waste material:

GENERATOR:	PORT OF TACOMA
MANIFEST #:	010585494JJK
CWM TRACKING ID:	42863001
PROFILE #:	OR321468
LINE ITEM:	9b.1
QUANTITY:	1 DT
RECEIVED DATE:	09/26/13
DISPOSAL PROCESS(ES):	LANDFILL
FINAL DISPOSAL LOCATION:	LANDFILL 13
DISPOSAL DATE:	09/26/13

I certify, on behalf of the above listed treatment facility, that to the best of my knowledge, the above-described waste material was managed in compliance with all applicable laws, regulations, permits and licenses on the date listed above.

CWMNW RECORDS DEPARTMENT

Date: 10/01/13



CHEMICAL WASTE MANAGEMENT OF THE NW

17629 Cedar Springs Lane
Arlington, OR 97812
(541) 454-2643
(541) 454-3279 Fax

PORT OF TACOMA
WAD001882984
3400 TAYLOR WAY
TACOMA WA 98421

CERTIFICATE OF DISPOSAL

Chemical Waste Management of the Northwest, Inc., ORD089452353, has received the following waste material:

GENERATOR:	PORT OF TACOMA
MANIFEST #:	010585490JJK
CWM TRACKING ID:	42862901
PROFILE #:	OR321468
LINE ITEM:	9b.1
QUANTITY:	1 DT
RECEIVED DATE:	09/26/13
DISPOSAL PROCESS(ES):	LANDFILL
FINAL DISPOSAL LOCATION:	LANDFILL 13
DISPOSAL DATE:	09/26/13

I certify, on behalf of the above listed treatment facility, that to the best of my knowledge, the above-described waste material was managed in compliance with all applicable laws, regulations, permits and licenses on the date listed above.

Bobbi Jobalvin

CWMNW RECORDS DEPARTMENT

Date: 10/01/13



CHEMICAL WASTE MANAGEMENT OF THE NW

17629 Cedar Springs Lane
Arlington, OR 97812
(541) 454-2643
(541) 454-3279 Fax

PORT OF TACOMA
WAD001882984
3400 TAYLOR WAY
TACOMA WA 98421

CERTIFICATE OF DISPOSAL

Chemical Waste Management of the Northwest, Inc., ORD089452353, has received the following waste material:

GENERATOR:	PORT OF TACOMA
MANIFEST #:	010585489JJK
CWM TRACKING ID:	42862801
PROFILE #:	OR321468
LINE ITEM:	9b.1
QUANTITY:	1 DT
RECEIVED DATE:	09/26/13
DISPOSAL PROCESS(ES):	LANDFILL
FINAL DISPOSAL LOCATION:	LANDFILL 13
DISPOSAL DATE:	09/26/13

I certify, on behalf of the above listed treatment facility, that to the best of my knowledge, the above-described waste material was managed in compliance with all applicable laws, regulations, permits and licenses on the date listed above.

Bobbi Jo Galvin

CWMNW RECORDS DEPARTMENT

Date: 10/01/13



CHEMICAL WASTE MANAGEMENT OF THE NW
17629 Cedar Springs Lane
Arlington, OR 97812
(541) 454-2643
(541) 454-3279 Fax

PORT OF TACOMA
WAD001882984
3400 TAYLOR WAY
TACOMA WA 98421

CERTIFICATE OF DISPOSAL

Chemical Waste Management of the Northwest, Inc., ORD089452353, has received the following waste material:

GENERATOR:	PORT OF TACOMA
MANIFEST #:	010585491JJK
CWM TRACKING ID:	42862701
PROFILE #:	OR321468
LINE ITEM:	9b.1
QUANTITY:	1 DT
RECEIVED DATE:	09/26/13
DISPOSAL PROCESS(ES):	LANDFILL
FINAL DISPOSAL LOCATION:	LANDFILL 13
DISPOSAL DATE:	09/26/13

I certify, on behalf of the above listed treatment facility, that to the best of my knowledge, the above-described waste material was managed in compliance with all applicable laws, regulations, permits and licenses on the date listed above.

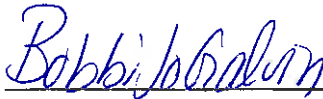

CWMNW RECORDS DEPARTMENT

Date: 10/01/13



CHEMICAL WASTE MANAGEMENT OF THE NW

17629 Cedar Springs Lane
Arlington, OR 97812
(541) 454-2643
(541) 454-3279 Fax

PORT OF TACOMA
WAD001882984
3400 TAYLOR WAY
TACOMA WA 98421

CERTIFICATE OF DISPOSAL

Chemical Waste Management of the Northwest, Inc., ORD089452353, has received the following waste material:

GENERATOR:	PORT OF TACOMA
MANIFEST #:	010585497JJK
CWM TRACKING ID:	42861101
PROFILE #:	OR321468
LINE ITEM:	9b.1
QUANTITY:	1 DT
RECEIVED DATE:	09/26/13
DISPOSAL PROCESS(ES):	LANDFILL
FINAL DISPOSAL LOCATION:	LANDFILL 13
DISPOSAL DATE:	09/26/13

I certify, on behalf of the above listed treatment facility, that to the best of my knowledge, the above-described waste material was managed in compliance with all applicable laws, regulations, permits and licenses on the date listed above.

Bobbi Jobalun

CWMNW RECORDS DEPARTMENT

Date: 10/01/13



CHEMICAL WASTE MANAGEMENT OF THE NW
17629 Cedar Springs Lane
Arlington, OR 97812
(541) 454-2643
(541) 454-3279 Fax

PORT OF TACOMA
WAD001882984
3400 TAYLOR WAY
TACOMA WA 98421

CERTIFICATE OF DISPOSAL

Chemical Waste Management of the Northwest, Inc., ORD089452353, has received the following waste material:

GENERATOR:	PORT OF TACOMA
MANIFEST #:	010585492JJK
CWM TRACKING ID:	42860901
PROFILE #:	OR321468
LINE ITEM:	9b.1
QUANTITY:	1 DT
RECEIVED DATE:	09/26/13
DISPOSAL PROCESS(ES):	LANDFILL
FINAL DISPOSAL LOCATION:	LANDFILL 13
DISPOSAL DATE:	09/26/13

I certify, on behalf of the above listed treatment facility, that to the best of my knowledge, the above-described waste material was managed in compliance with all applicable laws, regulations, permits and licenses on the date listed above.



CWMNW RECORDS DEPARTMENT
Date: 10/01/13



CHEMICAL WASTE MANAGEMENT OF THE NW
17629 Cedar Springs Lane
Arlington, OR 97812
(541) 454-2643
(541) 454-3279 Fax

PORT OF TACOMA
WAD001882984
3400 TAYLOR WAY
TACOMA WA 98421

CERTIFICATE OF DISPOSAL

Chemical Waste Management of the Northwest, Inc., ORD089452353, has received the following waste material:

GENERATOR:	PORT OF TACOMA
MANIFEST #:	010585496JJK
CWM TRACKING ID:	42864201
PROFILE #:	OR321468
LINE ITEM:	9b.1
QUANTITY:	1 DT
RECEIVED DATE:	09/26/13
DISPOSAL PROCESS(ES):	LANDFILL
FINAL DISPOSAL LOCATION:	LANDFILL 13
DISPOSAL DATE:	09/26/13

I certify, on behalf of the above listed treatment facility, that to the best of my knowledge, the above-described waste material was managed in compliance with all applicable laws, regulations, permits and licenses on the date listed above.

CWMNW RECORDS DEPARTMENT

Date: 10/07/13



CHEMICAL WASTE MANAGEMENT OF THE NW
17629 Cedar Springs Lane
Arlington, OR 97812
(541) 454-2643
(541) 454-3279 Fax

PORT OF TACOMA
WAD001882984
3400 TAYLOR WAY
TACOMA WA 98421

CERTIFICATE OF DISPOSAL

Chemical Waste Management of the Northwest, Inc., ORD089452353, has received the following waste material:

GENERATOR:	PORT OF TACOMA
MANIFEST #:	010585472JJK
CWM TRACKING ID:	42870501
PROFILE #:	OR321468
LINE ITEM:	9b.1
QUANTITY:	1 DT
RECEIVED DATE:	09/27/13
DISPOSAL PROCESS(ES):	LANDFILL
FINAL DISPOSAL LOCATION:	LANDFILL 13
DISPOSAL DATE:	09/27/13

I certify, on behalf of the above listed treatment facility, that to the best of my knowledge, the above-described waste material was managed in compliance with all applicable laws, regulations, permits and licenses on the date listed above.

Bobbi Jo Galvin

CWMNW RECORDS DEPARTMENT

Date: 10/04/13



CHEMICAL WASTE MANAGEMENT OF THE NW

17629 Cedar Springs Lane
Arlington, OR 97812
(541) 454-2643
(541) 454-3279 Fax

PORT OF TACOMA
WAD001882984
3400 TAYLOR WAY
TACOMA WA 98421

CERTIFICATE OF DISPOSAL

Chemical Waste Management of the Northwest, Inc., ORD089452353, has received the following waste material:

GENERATOR:	PORT OF TACOMA
MANIFEST #:	010585450JJK
CWM TRACKING ID:	42870601
PROFILE #:	OR321468
LINE ITEM:	9b.1
QUANTITY:	1 DT
RECEIVED DATE:	09/27/13
DISPOSAL PROCESS(ES):	LANDFILL
FINAL DISPOSAL LOCATION:	LANDFILL 13
DISPOSAL DATE:	09/27/13

I certify, on behalf of the above listed treatment facility, that to the best of my knowledge, the above-described waste material was managed in compliance with all applicable laws, regulations, permits and licenses on the date listed above.

Bobbi Jo Calvin

CWMNW RECORDS DEPARTMENT

Date: 10/04/13



CHEMICAL WASTE MANAGEMENT OF THE NW

17629 Cedar Springs Lane
Arlington, OR 97812
(541) 454-2643
(541) 454-3279 Fax

PORT OF TACOMA
WAD001882984
3400 TAYLOR WAY
TACOMA WA 98421

CERTIFICATE OF DISPOSAL

Chemical Waste Management of the Northwest, Inc., ORD089452353, has received the following waste material:

GENERATOR: PORT OF TACOMA
MANIFEST #: 010585460JJK
CWM TRACKING ID: 42871001
PROFILE #: OR321468
LINE ITEM: 9b.1
QUANTITY: 1 DT
RECEIVED DATE: 09/27/13

DISPOSAL PROCESS(ES): LANDFILL
FINAL DISPOSAL LOCATION: LANDFILL 13
DISPOSAL DATE: 09/27/13

I certify, on behalf of the above listed treatment facility, that to the best of my knowledge, the above-described waste material was managed in compliance with all applicable laws, regulations, permits and licenses on the date listed above.

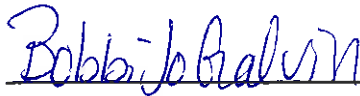

CWMNW RECORDS DEPARTMENT

Date: 10/04/13



CHEMICAL WASTE MANAGEMENT OF THE NW
17629 Cedar Springs Lane
Arlington, OR 97812
(541) 454-2643
(541) 454-3279 Fax

PORT OF TACOMA
WAD001882984
3400 TAYLOR WAY
TACOMA WA 98421

CERTIFICATE OF DISPOSAL

Chemical Waste Management of the Northwest, Inc., ORD089452353, has received the following waste material:

GENERATOR:	PORT OF TACOMA
MANIFEST #:	010585458JJK
CWM TRACKING ID:	42871101
PROFILE #:	OR321468
LINE ITEM:	9b.1
QUANTITY:	1 DT
RECEIVED DATE:	09/27/13
DISPOSAL PROCESS(ES):	LANDFILL
FINAL DISPOSAL LOCATION:	LANDFILL 13
DISPOSAL DATE:	09/27/13

I certify, on behalf of the above listed treatment facility, that to the best of my knowledge, the above-described waste material was managed in compliance with all applicable laws, regulations, permits and licenses on the date listed above.

Bobbi Jo Galvin

CWMNW RECORDS DEPARTMENT
Date: 10/04/13



CHEMICAL WASTE MANAGEMENT OF THE NW

17629 Cedar Springs Lane
Arlington, OR 97812
(541) 454-2643
(541) 454-3279 Fax

PORT OF TACOMA
WAD001882984
3400 TAYLOR WAY
TACOMA WA 98421

CERTIFICATE OF DISPOSAL

Chemical Waste Management of the Northwest, Inc., ORD089452353, has received the following waste material:

GENERATOR:	PORT OF TACOMA
MANIFEST #:	010585457JJK
CWM TRACKING ID:	42869701
PROFILE #:	OR321468
LINE ITEM:	9b.1
QUANTITY:	1 DT
RECEIVED DATE:	09/27/13
DISPOSAL PROCESS(ES):	LANDFILL
FINAL DISPOSAL LOCATION:	LANDFILL 13
DISPOSAL DATE:	09/27/13

I certify, on behalf of the above listed treatment facility, that to the best of my knowledge, the above-described waste material was managed in compliance with all applicable laws, regulations, permits and licenses on the date listed above.

Bobbi Jo Galvin

CWMNW RECORDS DEPARTMENT

Date: 10/04/13



CHEMICAL WASTE MANAGEMENT OF THE NW

17629 Cedar Springs Lane
Arlington, OR 97812
(541) 454-2643
(541) 454-3279 Fax

PORT OF TACOMA
WAD001882984
3400 TAYLOR WAY
TACOMA WA 98421

CERTIFICATE OF DISPOSAL

Chemical Waste Management of the Northwest, Inc., ORD089452353, has received the following waste material:

GENERATOR: PORT OF TACOMA
MANIFEST #: 010585471JJK
CWM TRACKING ID: 42869501
PROFILE #: OR321468
LINE ITEM: 9b.1
QUANTITY: 1 DT
RECEIVED DATE: 09/27/13

DISPOSAL PROCESS(ES): LANDFILL
FINAL DISPOSAL LOCATION: LANDFILL 13
DISPOSAL DATE: 09/27/13

I certify, on behalf of the above listed treatment facility, that to the best of my knowledge, the above-described waste material was managed in compliance with all applicable laws, regulations, permits and licenses on the date listed above.



CWMNW RECORDS DEPARTMENT

Date: 10/04/13



CHEMICAL WASTE MANAGEMENT OF THE NW

17629 Cedar Springs Lane
Arlington, OR 97812
(541) 454-2643
(541) 454-3279 Fax

PORT OF TACOMA
WAD001882984
3400 TAYLOR WAY
TACOMA WA 98421

CERTIFICATE OF DISPOSAL

Chemical Waste Management of the Northwest, Inc., ORD089452353, has received the following waste material:

GENERATOR:	PORT OF TACOMA
MANIFEST #:	010585447JJK
CWM TRACKING ID:	42869401
PROFILE #:	OR321468
LINE ITEM:	9b.1
QUANTITY:	1 DT
RECEIVED DATE:	09/27/13
DISPOSAL PROCESS(ES):	LANDFILL
FINAL DISPOSAL LOCATION:	LANDFILL 13
DISPOSAL DATE:	09/27/13

I certify, on behalf of the above listed treatment facility, that to the best of my knowledge, the above-described waste material was managed in compliance with all applicable laws, regulations, permits and licenses on the date listed above.



CWMNW RECORDS DEPARTMENT

Date: 10/04/13



CHEMICAL WASTE MANAGEMENT OF THE NW

17629 Cedar Springs Lane
Arlington, OR 97812
(541) 454-2643
(541) 454-3279 Fax

PORT OF TACOMA
WAD001882984
3400 TAYLOR WAY
TACOMA WA 98421

CERTIFICATE OF DISPOSAL

Chemical Waste Management of the Northwest, Inc., ORD089452353, has received the following waste material:

GENERATOR:	PORT OF TACOMA
MANIFEST #:	010585463JJK
CWM TRACKING ID:	42869201
PROFILE #:	OR321468
LINE ITEM:	9b.1
QUANTITY:	1 DT
RECEIVED DATE:	09/27/13
DISPOSAL PROCESS(ES):	LANDFILL
FINAL DISPOSAL LOCATION:	LANDFILL 13
DISPOSAL DATE:	09/27/13

I certify, on behalf of the above listed treatment facility, that to the best of my knowledge, the above-described waste material was managed in compliance with all applicable laws, regulations, permits and licenses on the date listed above.



CWMNW RECORDS DEPARTMENT

Date: 10/04/13



CHEMICAL WASTE MANAGEMENT OF THE NW

17629 Cedar Springs Lane
Arlington, OR 97812
(541) 454-2643
(541) 454-3279 Fax

PORT OF TACOMA
WAD001882984
3400 TAYLOR WAY
TACOMA WA 98421

CERTIFICATE OF DISPOSAL

Chemical Waste Management of the Northwest, Inc., ORD089452353, has received the following waste material:

GENERATOR: PORT OF TACOMA
MANIFEST #: 010585466JJK
CWM TRACKING ID: 42869101
PROFILE #: OR321468
LINE ITEM: 9b.1
QUANTITY: 1 DT
RECEIVED DATE: 09/27/13

DISPOSAL PROCESS(ES): LANDFILL
FINAL DISPOSAL LOCATION: LANDFILL 13
DISPOSAL DATE: 09/27/13

I certify, on behalf of the above listed treatment facility, that to the best of my knowledge, the above-described waste material was managed in compliance with all applicable laws, regulations, permits and licenses on the date listed above.



CWMNW RECORDS DEPARTMENT

Date: 10/04/13



CHEMICAL WASTE MANAGEMENT OF THE NW

17629 Cedar Springs Lane
Arlington, OR 97812
(541) 454-2643
(541) 454-3279 Fax

PORT OF TACOMA
WAD001882984
3400 TAYLOR WAY
TACOMA WA 98421

CERTIFICATE OF DISPOSAL

Chemical Waste Management of the Northwest, Inc., ORD089452353, has received the following waste material:

GENERATOR:	PORT OF TACOMA
MANIFEST #:	010585455JK
CWM TRACKING ID:	42869001
PROFILE #:	OR321468
LINE ITEM:	9b.1
QUANTITY:	1 DT
RECEIVED DATE:	09/27/13
DISPOSAL PROCESS(ES):	LANDFILL
FINAL DISPOSAL LOCATION:	LANDFILL 13
DISPOSAL DATE:	09/27/13

I certify, on behalf of the above listed treatment facility, that to the best of my knowledge, the above-described waste material was managed in compliance with all applicable laws, regulations, permits and licenses on the date listed above.

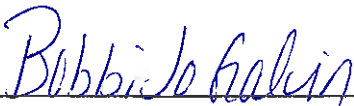

CWMNW RECORDS DEPARTMENT

Date: 10/04/13



CHEMICAL WASTE MANAGEMENT OF THE NW

17629 Cedar Springs Lane
Arlington, OR 97812
(541) 454-2643
(541) 454-3279 Fax

PORT OF TACOMA
WAD001882984
3400 TAYLOR WAY
TACOMA WA 98421

CERTIFICATE OF DISPOSAL

Chemical Waste Management of the Northwest, Inc., ORD089452353, has received the following waste material:

GENERATOR:	PORT OF TACOMA
MANIFEST #:	010585462JJK
CWM TRACKING ID:	42868901
PROFILE #:	OR321468
LINE ITEM:	9b.1
QUANTITY:	1 DT
RECEIVED DATE:	09/27/13
DISPOSAL PROCESS(ES):	LANDFILL
FINAL DISPOSAL LOCATION:	LANDFILL 13
DISPOSAL DATE:	09/27/13

I certify, on behalf of the above listed treatment facility, that to the best of my knowledge, the above-described waste material was managed in compliance with all applicable laws, regulations, permits and licenses on the date listed above.

Bobbi Jofralin

CWMNW RECORDS DEPARTMENT

Date: 10/04/13



CHEMICAL WASTE MANAGEMENT OF THE NW

17629 Cedar Springs Lane
Arlington, OR 97812
(541) 454-2643
(541) 454-3279 Fax

PORT OF TACOMA
WAD001882984
3400 TAYLOR WAY
TACOMA WA 98421

CERTIFICATE OF DISPOSAL

Chemical Waste Management of the Northwest, Inc., ORD089452353, has received the following waste material:

GENERATOR:	PORT OF TACOMA
MANIFEST #:	010585456JJK
CWM TRACKING ID:	42868701
PROFILE #:	OR321468
LINE ITEM:	9b.1
QUANTITY:	1 DT
RECEIVED DATE:	09/27/13
DISPOSAL PROCESS(ES):	LANDFILL
FINAL DISPOSAL LOCATION:	LANDFILL 13
DISPOSAL DATE:	09/27/13

I certify, on behalf of the above listed treatment facility, that to the best of my knowledge, the above-described waste material was managed in compliance with all applicable laws, regulations, permits and licenses on the date listed above.

CWMNW RECORDS DEPARTMENT

Date: 10/04/13



CHEMICAL WASTE MANAGEMENT OF THE NW

17629 Cedar Springs Lane
Arlington, OR 97812
(541) 454-2643
(541) 454-3279 Fax

PORT OF TACOMA
WAD001882984
3400 TAYLOR WAY
TACOMA WA 98421

CERTIFICATE OF DISPOSAL

Chemical Waste Management of the Northwest, Inc., ORD089452353, has received the following waste material:

GENERATOR:	PORT OF TACOMA
MANIFEST #:	010585467JJK
CWM TRACKING ID:	42868201
PROFILE #:	OR321468
LINE ITEM:	9b.1
QUANTITY:	1 DT
RECEIVED DATE:	09/27/13
DISPOSAL PROCESS(ES):	LANDFILL
FINAL DISPOSAL LOCATION:	LANDFILL 13
DISPOSAL DATE:	09/27/13

I certify, on behalf of the above listed treatment facility, that to the best of my knowledge, the above-described waste material was managed in compliance with all applicable laws, regulations, permits and licenses on the date listed above.

Bobbi Jo Galvin

CWMNW RECORDS DEPARTMENT

Date: 10/04/13



CHEMICAL WASTE MANAGEMENT OF THE NW

17629 Cedar Springs Lane
Arlington, OR 97812
(541) 454-2643
(541) 454-3279 Fax

PORT OF TACOMA
WAD001882984
3400 TAYLOR WAY
TACOMA WA 98421

CERTIFICATE OF DISPOSAL

Chemical Waste Management of the Northwest, Inc., ORD089452353, has received the following waste material:

GENERATOR:	PORT OF TACOMA
MANIFEST #:	010585459JJK
CWM TRACKING ID:	42868101
PROFILE #:	OR321468
LINE ITEM:	9b.1
QUANTITY:	1 DT
RECEIVED DATE:	09/27/13
DISPOSAL PROCESS(ES):	LANDFILL
FINAL DISPOSAL LOCATION:	LANDFILL 13
DISPOSAL DATE:	09/27/13

I certify, on behalf of the above listed treatment facility, that to the best of my knowledge, the above-described waste material was managed in compliance with all applicable laws, regulations, permits and licenses on the date listed above.

Bobbi Jofalvin

CWMNW RECORDS DEPARTMENT

Date: 10/04/13



CHEMICAL WASTE MANAGEMENT OF THE NW

17629 Cedar Springs Lane
Arlington, OR 97812
(541) 454-2643
(541) 454-3279 Fax

PORT OF TACOMA
WAD001882984
3400 TAYLOR WAY
TACOMA WA 98421

CERTIFICATE OF DISPOSAL

Chemical Waste Management of the Northwest, Inc., ORD089452353, has received the following waste material:

GENERATOR:	PORT OF TACOMA
MANIFEST #:	010585461JJK
CWM TRACKING ID:	42871401
PROFILE #:	OR321468
LINE ITEM:	9b.1
QUANTITY:	1 D7
RECEIVED DATE:	09/27/13
DISPOSAL PROCESS(ES):	LANDFILL
FINAL DISPOSAL LOCATION:	LANDFILL 13
DISPOSAL DATE:	09/27/13

I certify, on behalf of the above listed treatment facility, that to the best of my knowledge, the above-described waste material was managed in compliance with all applicable laws, regulations, permits and licenses on the date listed above.

CWMNW RECORDS DEPARTMENT

Date: 10/04/13



CHEMICAL WASTE MANAGEMENT OF THE NW

17629 Cedar Springs Lane
Arlington, OR 97812
(541) 454-2643
(541) 454-3279 Fax

PORT OF TACOMA
WAD001882984
3400 TAYLOR WAY
TACOMA WA 98421

CERTIFICATE OF DISPOSAL

Chemical Waste Management of the Northwest, Inc., ORD089452353, has received the following waste material:

GENERATOR:	PORT OF TACOMA
MANIFEST #:	010585451JJK
CWM TRACKING ID:	42871301
PROFILE #:	OR321468
LINE ITEM:	9b.1
QUANTITY:	1 DT
RECEIVED DATE:	09/27/13
DISPOSAL PROCESS(ES):	LANDFILL
FINAL DISPOSAL LOCATION:	LANDFILL 13
DISPOSAL DATE:	09/27/13

I certify, on behalf of the above listed treatment facility, that to the best of my knowledge, the above-described waste material was managed in compliance with all applicable laws, regulations, permits and licenses on the date listed above.

Bobbi Jo Galvin

CWMNW RECORDS DEPARTMENT

Date: 10/04/13



CHEMICAL WASTE MANAGEMENT OF THE NW

17629 Cedar Springs Lane
Arlington, OR 97812
(541) 454-2643
(541) 454-3279 Fax

PORT OF TACOMA
WAD001882984
3400 TAYLOR WAY
TACOMA WA 98421

CERTIFICATE OF DISPOSAL

Chemical Waste Management of the Northwest, Inc., ORD089452353, has received the following waste material:

GENERATOR:	PORT OF TACOMA
MANIFEST #:	010585468JJK
CWM TRACKING ID:	42869801
PROFILE #:	OR321468
LINE ITEM:	9b.1
QUANTITY:	1 DT
RECEIVED DATE:	09/27/13
DISPOSAL PROCESS(ES):	LANDFILL
FINAL DISPOSAL LOCATION:	LANDFILL 13
DISPOSAL DATE:	09/27/13

I certify, on behalf of the above listed treatment facility, that to the best of my knowledge, the above-described waste material was managed in compliance with all applicable laws, regulations, permits and licenses on the date listed above.



CWMNW RECORDS DEPARTMENT

Date: 10/04/13



CHEMICAL WASTE MANAGEMENT OF THE NW
17629 Cedar Springs Lane
Arlington, OR 97812
(541) 454-2643
(541) 454-3279 Fax

PORT OF TACOMA
WAD001882984
3400 TAYLOR WAY
TACOMA WA 98421

CERTIFICATE OF DISPOSAL

Chemical Waste Management of the Northwest, Inc., ORD089452353, has received the following waste material:

GENERATOR:	PORT OF TACOMA
MANIFEST #:	010585449JJK
CWM TRACKING ID:	42869901
PROFILE #:	OR321468
LINE ITEM:	9b.1
QUANTITY:	1 DT
RECEIVED DATE:	09/27/13
DISPOSAL PROCESS(ES):	LANDFILL
FINAL DISPOSAL LOCATION:	LANDFILL 13
DISPOSAL DATE:	09/27/13

I certify, on behalf of the above listed treatment facility, that to the best of my knowledge, the above-described waste material was managed in compliance with all applicable laws, regulations, permits and licenses on the date listed above.

CWMNW RECORDS DEPARTMENT

Date: 10/04/13



CHEMICAL WASTE MANAGEMENT OF THE NW

17629 Cedar Springs Lane
Arlington, OR 97812
(541) 454-2643
(541) 454-3279 Fax

PORT OF TACOMA
WAD001882984
3400 TAYLOR WAY
TACOMA WA 98421

CERTIFICATE OF DISPOSAL

Chemical Waste Management of the Northwest, Inc., ORD089452353, has received the following waste material:

GENERATOR:	PORT OF TACOMA
MANIFEST #:	010585464JJK
CWM TRACKING ID:	42810001
PROFILE #:	OR321468
LINE ITEM:	9b.1
QUANTITY:	1 DT
RECEIVED DATE:	09/27/13
DISPOSAL PROCESS(ES):	LANDFILL
FINAL DISPOSAL LOCATION:	LANDFILL 13
DISPOSAL DATE:	09/27/13

I certify, on behalf of the above listed treatment facility, that to the best of my knowledge, the above-described waste material was managed in compliance with all applicable laws, regulations, permits and licenses on the date listed above.

Robbie Jobalvin

CWMNW RECORDS DEPARTMENT

Date: 10/04/13



CHEMICAL WASTE MANAGEMENT OF THE NW
 17629 Cedar Springs Lane
 Arlington, OR 97812
 (541) 454-2643
 (541) 454-3279 Fax

PORT OF TACOMA
 WAD001882984
 3400 TAYLOR WAY
 TACOMA WA 98421

CERTIFICATE OF DISPOSAL

Chemical Waste Management of the Northwest, Inc., ORD089452353, has received the following waste material:

GENERATOR:	PORT OF TACOMA
MANIFEST #:	010585446JJK
CWM TRACKING ID:	42870101
PROFILE #:	OR321468
LINE ITEM:	9b.1
QUANTITY:	1 DT
RECEIVED DATE:	09/27/13
DISPOSAL PROCESS(ES):	LANDFILL
FINAL DISPOSAL LOCATION:	LANDFILL 13
DISPOSAL DATE:	09/27/13

I certify, on behalf of the above listed treatment facility, that to the best of my knowledge, the above-described waste material was managed in compliance with all applicable laws, regulations, permits and licenses on the date listed above.

Bobbi J. Galvin

CWMNW RECORDS DEPARTMENT
 Date: 10/04/13



CHEMICAL WASTE MANAGEMENT OF THE NW
17629 Cedar Springs Lane
Arlington, OR 97812
(541) 454-2643
(541) 454-3279 Fax

PORT OF TACOMA
WAD001882984
3400 TAYLOR WAY
TACOMA WA 98421

CERTIFICATE OF DISPOSAL

Chemical Waste Management of the Northwest, Inc., ORD089452353, has received the following waste material:

GENERATOR:	PORT OF TACOMA
MANIFEST #:	010585448JJK
CWM TRACKING ID:	42870201
PROFILE #:	OR321468
LINE ITEM:	9b.1
QUANTITY:	1 DT
RECEIVED DATE:	09/27/13
DISPOSAL PROCESS(ES):	LANDFILL
FINAL DISPOSAL LOCATION:	LANDFILL 13
DISPOSAL DATE:	09/27/13

I certify, on behalf of the above listed treatment facility, that to the best of my knowledge, the above-described waste material was managed in compliance with all applicable laws, regulations, permits and licenses on the date listed above.

Bobbi Jo Galvin

CWMNW RECORDS DEPARTMENT

Date: 10/04/13



CHEMICAL WASTE MANAGEMENT OF THE NW

17629 Cedar Springs Lane
Arlington, OR 97812
(541) 454-2643
(541) 454-3279 Fax

PORT OF TACOMA
WAD001882984
3400 TAYLOR WAY
TACOMA WA 98421

CERTIFICATE OF DISPOSAL

Chemical Waste Management of the Northwest, Inc., ORD089452353, has received the following waste material:

GENERATOR:	PORT OF TACOMA
MANIFEST #:	010585445JJK
CWM TRACKING ID:	42870301
PROFILE #:	OR321468
LINE ITEM:	9b.1
QUANTITY:	1 DT
RECEIVED DATE:	09/27/13
DISPOSAL PROCESS(ES):	LANDFILL
FINAL DISPOSAL LOCATION:	LANDFILL 13
DISPOSAL DATE:	09/27/13

I certify, on behalf of the above listed treatment facility, that to the best of my knowledge, the above-described waste material was managed in compliance with all applicable laws, regulations, permits and licenses on the date listed above.



CWMNW RECORDS DEPARTMENT

Date: 10/04/13



CHEMICAL WASTE MANAGEMENT OF THE NW
17629 Cedar Springs Lane
Arlington, OR 97812
(541) 454-2643
(541) 454-3279 Fax

PORT OF TACOMA
WAD001882984
3400 TAYLOR WAY
TACOMA WA 98421

CERTIFICATE OF DISPOSAL

Chemical Waste Management of the Northwest, Inc., ORD089452353, has received the following waste material:

GENERATOR:	PORT OF TACOMA
MANIFEST #:	010585465JJK
CWM TRACKING ID:	42870401
PROFILE #:	OR321468
LINE ITEM:	9b.1
QUANTITY:	1 DT
RECEIVED DATE:	09/27/13
DISPOSAL PROCESS(ES):	LANDFILL
FINAL DISPOSAL LOCATION:	LANDFILL 13
DISPOSAL DATE:	09/27/13

I certify, on behalf of the above listed treatment facility, that to the best of my knowledge, the above-described waste material was managed in compliance with all applicable laws, regulations, permits and licenses on the date listed above.

CWMNW RECORDS DEPARTMENT

Date: 10/04/13



CHEMICAL WASTE MANAGEMENT OF THE NW
17629 Cedar Springs Lane
Arlington, OR 97812
(541) 454-2643
(541) 454-3279 Fax

PORT OF TACOMA
WAD001882984
3400 TAYLOR WAY
TACOMA WA 98421

CERTIFICATE OF DISPOSAL

Chemical Waste Management of the Northwest, Inc., ORD089452353, has received the following waste material:

GENERATOR:	PORT OF TACOMA
MANIFEST #:	010585469JJK
CWM TRACKING ID:	42867501
PROFILE #:	OR321468
LINE ITEM:	9b.1
QUANTITY:	1 D'1
RECEIVED DATE:	09/27/13
DISPOSAL PROCESS(ES):	LANDFILL
FINAL DISPOSAL LOCATION:	LANDFILL 13
DISPOSAL DATE:	09/27/13

I certify, on behalf of the above listed treatment facility, that to the best of my knowledge, the above-described waste material was managed in compliance with all applicable laws, regulations, permits and licenses on the date listed above.

Bobbi Jo Galvin

CWMNW RECORDS DEPARTMENT

Date: 10/04/13





CHEMICAL WASTE MANAGEMENT OF THE NW

17629 Cedar Springs Lane
Arlington, OR 97812
(541) 454-2643
(541) 454-3279 Fax

PORT OF TACOMA
WAD001882984
3400 TAYLOR WAY
TACOMA WA 98421

CERTIFICATE OF DISPOSAL

Chemical Waste Management of the Northwest, Inc., ORD089452353, has received the following waste material:

GENERATOR:	PORT OF TACOMA
MANIFEST #:	010585443JJK
CWM TRACKING ID:	42876301
PROFILE #:	OR321468
LINE ITEM:	9b.1
QUANTITY:	1 DT
RECEIVED DATE:	09/30/13
DISPOSAL PROCESS(ES):	LANDFILL
FINAL DISPOSAL LOCATION:	LANDFILL 13
DISPOSAL DATE:	09/30/13

I certify, on behalf of the above listed treatment facility, that to the best of my knowledge, the above-described waste material was managed in compliance with all applicable laws, regulations, permits and licenses on the date listed above.

Robbi Jofralvin

CWMNW RECORDS DEPARTMENT

Date: 10/04/13





CHEMICAL WASTE MANAGEMENT OF THE NW

17629 Cedar Springs Lane
Arlington, OR 97812
(541) 454-2643
(541) 454-3279 Fax

PORT OF TACOMA
WAD001882984
3400 TAYLOR WAY
TAOMA WA 98421

CERTIFICATE OF DISPOSAL

Chemical Waste Management of the Northwest, Inc., ORD089452353, has received the following waste material:

GENERATOR:	PORT OF TACOMA
MANIFEST #:	011886515JJK
CWM TRACKING ID:	42875401
PROFILE #:	OR321468
LINE ITEM:	9b.1
QUANTITY:	1 DT
RECEIVED DATE:	09/30/13
DISPOSAL PROCESS(ES):	LANDFILL
FINAL DISPOSAL LOCATION:	LANDFILL 13
DISPOSAL DATE:	09/30/13

I certify, on behalf of the above listed treatment facility, that to the best of my knowledge, the above-described waste material was managed in compliance with all applicable laws, regulations, permits and licenses on the date listed above.

Robbi Jo Galvin

CWMNW RECORDS DEPARTMENT

Date: 10/04/13





CHEMICAL WASTE MANAGEMENT OF THE NW
17629 Cedar Springs Lane
Arlington, OR 97812
(541) 454-2643
(541) 454-3279 Fax

PORT OF TACOMA
WAD001882984
3400 TAYLOR WAY
TAOMA WA 98421

CERTIFICATE OF DISPOSAL

Chemical Waste Management of the Northwest, Inc., ORD089452353, has received the following waste material:

GENERATOR: PORT OF TACOMA
MANIFEST #: 011886514JJK
CWM TRACKING ID: 42875201
PROFILE #: OR321468
LINE ITEM: 9b.1
QUANTITY: 1 DT
RECEIVED DATE: 09/30/13

DISPOSAL PROCESS(ES): LANDFILL
FINAL DISPOSAL LOCATION: LANDFILL 13
DISPOSAL DATE: 09/30/13

I certify, on behalf of the above listed treatment facility, that to the best of my knowledge, the above-described waste material was managed in compliance with all applicable laws, regulations, permits and licenses on the date listed above.



CWMNW RECORDS DEPARTMENT

Date: 10/04/13



CHEMICAL WASTE MANAGEMENT OF THE NW

17629 Cedar Springs Lane
Arlington, OR 97812
(541) 454-2643
(541) 454-3279 Fax

PORT OF TACOMA
WAD001882984
3400 TAYLOR WAY
TAOMA WA 98421

CERTIFICATE OF DISPOSAL

Chemical Waste Management of the Northwest, Inc., ORD089452353, has received the following waste material:

GENERATOR: PORT OF TACOMA
MANIFEST #: 010585444JJK
CWM TRACKING ID: 42875101
PROFILE #: OR321468
LINE ITEM: 9b.1
QUANTITY: 1 DT
RECEIVED DATE: 09/30/13

DISPOSAL PROCESS(ES): LANDFILL
FINAL DISPOSAL LOCATION: LANDFILL 13
DISPOSAL DATE: 09/30/13

I certify, on behalf of the above listed treatment facility, that to the best of my knowledge, the above-described waste material was managed in compliance with all applicable laws, regulations, permits and licenses on the date listed above.

Bobbi Jo Galvin

CWMNW RECORDS DEPARTMENT

Date: 10/04/13



CHEMICAL WASTE MANAGEMENT OF THE NW

17629 Cedar Springs Lane
Arlington, OR 97812
(541) 454-2643
(541) 454-3279 Fax

PORT OF TACOMA
WAD001882984
3400 TAYLOR WAY
TAOMA WA 98421

CERTIFICATE OF DISPOSAL

Chemical Waste Management of the Northwest, Inc., ORD089452353, has received the following waste material:

GENERATOR:	PORT OF TACOMA
MANIFEST #:	010585452JJK
CWM TRACKING ID:	42875001
PROFILE #:	OR321468
LINE ITEM:	9b.1
QUANTITY:	1 DT
RECEIVED DATE:	09/30/13
DISPOSAL PROCESS(ES):	LANDFILL
FINAL DISPOSAL LOCATION:	LANDFILL 13
DISPOSAL DATE:	09/30/13

I certify, on behalf of the above listed treatment facility, that to the best of my knowledge, the above-described waste material was managed in compliance with all applicable laws, regulations, permits and licenses on the date listed above.



CWMNW RECORDS DEPARTMENT

Date: 10/04/13



CHEMICAL WASTE MANAGEMENT OF THE NW

17629 Cedar Springs Lane
Arlington, OR 97812
(541) 454-2643
(541) 454-3279 Fax

PORT OF TACOMA
WAD001882984
3400 TAYLOR WAY
TACOMA WA 98421

CERTIFICATE OF DISPOSAL

Chemical Waste Management of the Northwest, Inc., ORD089452353, has received the following waste material:

GENERATOR:	PORT OF TACOMA
MANIFEST #:	010585439JJK
CWM TRACKING ID:	42874901
PROFILE #:	OR321468
LINE ITEM:	9b.1
QUANTITY:	1 D ³
RECEIVED DATE:	09/30/13
DISPOSAL PROCESS(ES):	LANDFILL
FINAL DISPOSAL LOCATION:	LANDFILL 13
DISPOSAL DATE:	09/30/13

I certify, on behalf of the above listed treatment facility, that to the best of my knowledge, the above-described waste material was managed in compliance with all applicable laws, regulations, permits and licenses on the date listed above.



CWMNW RECORDS DEPARTMENT

Date: 10/04/13



CHEMICAL WASTE MANAGEMENT OF THE NW

17629 Cedar Springs Lane
Arlington, OR 97812
(541) 454-2643
(541) 454-3279 Fax

PORT OF TACOMA
WAD001882984
3400 TAYLOR WAY
TAOMA WA 98421

CERTIFICATE OF DISPOSAL

Chemical Waste Management of the Northwest, Inc., ORD089452353, has received the following waste material:

GENERATOR:	PORT OF TACOMA
MANIFEST #:	011886526JJK
CWM TRACKING ID:	42874801
PROFILE #:	OR321468
LINE ITEM:	9b.1
QUANTITY:	1 DT
RECEIVED DATE:	09/30/13
DISPOSAL PROCESS(ES):	LANDFILL
FINAL DISPOSAL LOCATION:	LANDFILL 13
DISPOSAL DATE:	09/30/13

I certify, on behalf of the above listed treatment facility, that to the best of my knowledge, the above-described waste material was managed in compliance with all applicable laws, regulations, permits and licenses on the date listed above.

Bobbi Jo Bealun

CWMNW RECORDS DEPARTMENT

Date: 10/04/13





CHEMICAL WASTE MANAGEMENT OF THE NW
17629 Cedar Springs Lane
Arlington, OR 97812
(541) 454-2643
(541) 454-3279 Fax

PORT OF TACOMA
WAD001882984
3400 TAYLOR WAY
TACOMA WA 98421

CERTIFICATE OF DISPOSAL

Chemical Waste Management of the Northwest, Inc., ORD089452353, has received the following waste material:

GENERATOR: PORT OF TACOMA
MANIFEST #: 010585441JJK
CWM TRACKING ID: 42874701
PROFILE #: OR321468
LINE ITEM: 9b.1
QUANTITY: 1 DT
RECEIVED DATE: 09/30/13

DISPOSAL PROCESS(ES): LANDFILL
FINAL DISPOSAL LOCATION: LANDFILL 13
DISPOSAL DATE: 09/30/13

I certify, on behalf of the above listed treatment facility, that to the best of my knowledge, the above-described waste material was managed in compliance with all applicable laws, regulations, permits and licenses on the date listed above.

Bobbi Jo Galvin

CWMNW RECORDS DEPARTMENT

Date: 10/04/13



CHEMICAL WASTE MANAGEMENT OF THE NW

17629 Cedar Springs Lane
Arlington, OR 97812
(541) 454-2643
(541) 454-3279 Fax

PORT OF TACOMA
WAD001882984
3400 TAYLOR WAY
TAOMA WA 98421

CERTIFICATE OF DISPOSAL

Chemical Waste Management of the Northwest, Inc., ORD089452353, has received the following waste material:

GENERATOR:	PORT OF TACOMA
MANIFEST #:	010585435JJK
CWM TRACKING ID:	42874601
PROFILE #:	OR321468
LINE ITEM:	9b.1
QUANTITY:	1 DT
RECEIVED DATE:	09/30/13
DISPOSAL PROCESS(ES):	LANDFILL
FINAL DISPOSAL LOCATION:	LANDFILL 13
DISPOSAL DATE:	09/30/13

I certify, on behalf of the above listed treatment facility, that to the best of my knowledge, the above-described waste material was managed in compliance with all applicable laws, regulations, permits and licenses on the date listed above.

Bibbi Jo Galvin

CWMNW RECORDS DEPARTMENT

Date: 10/04/13



CHEMICAL WASTE MANAGEMENT OF THE NW

17629 Cedar Springs Lane
Arlington, OR 97812
(541) 454-2643
(541) 454-3279 Fax

PORT OF TACOMA
WAD001882984
3400 TAYLOR WAY
TAOMA WA 98421

CERTIFICATE OF DISPOSAL

Chemical Waste Management of the Northwest, Inc., ORD089452353, has received the following waste material:

GENERATOR: PORT OF TACOMA
MANIFEST #: 010585438JJK
CWM TRACKING ID: 42874501
PROFILE #: OR321468
LINE ITEM: 9b.1
QUANTITY: 1 DT
RECEIVED DATE: 09/30/13

DISPOSAL PROCESS(ES): LANDFILL
FINAL DISPOSAL LOCATION: LANDFILL 13
DISPOSAL DATE: 09/30/13

I certify, on behalf of the above listed treatment facility, that to the best of my knowledge, the above-described waste material was managed in compliance with all applicable laws, regulations, permits and licenses on the date listed above.

CWMNW RECORDS DEPARTMENT

Date: 10/04/13



CHEMICAL WASTE MANAGEMENT OF THE NW

17629 Cedar Springs Lane
Arlington, OR 97812
(541) 454-2643
(541) 454-3279 Fax

PORT OF TACOMA
WAD001882984
3400 TAYLOR WAY
TAOMA WA 98421

CERTIFICATE OF DISPOSAL

Chemical Waste Management of the Northwest, Inc., ORD089452353, has received the following waste material:

GENERATOR:	PORT OF TACOMA
MANIFEST #:	010585440JJK
CWM TRACKING ID:	42874401
PROFILE #:	OR321468
LINE ITEM:	9b.1
QUANTITY:	1 DT
RECEIVED DATE:	09/30/13
DISPOSAL PROCESS(ES):	LANDFILL
FINAL DISPOSAL LOCATION:	LANDFILL 13
DISPOSAL DATE:	09/30/13

I certify, on behalf of the above listed treatment facility, that to the best of my knowledge, the above-described waste material was managed in compliance with all applicable laws, regulations, permits and licenses on the date listed above.

Robbi Jo Galvin

CWMNW RECORDS DEPARTMENT

Date: 10/04/13



CHEMICAL WASTE MANAGEMENT OF THE NW

17629 Cedar Springs Lane
Arlington, OR 97812
(541) 454-2643
(541) 454-3279 Fax

PORT OF TACOMA
WAD001882984
3400 TAYLOR WAY
TAOMA WA 98421

CERTIFICATE OF DISPOSAL

Chemical Waste Management of the Northwest, Inc., ORD089452353, has received the following waste material:

GENERATOR:	PORT OF TACOMA
MANIFEST #:	010585442JJK
CWM TRACKING ID:	42874301
PROFILE #:	OR321468
LINE ITEM:	9b.1
QUANTITY:	1 DT
RECEIVED DATE:	09/30/13
DISPOSAL PROCESS(ES):	LANDFILL
FINAL DISPOSAL LOCATION:	LANDFILL 13
DISPOSAL DATE:	09/30/13

I certify, on behalf of the above listed treatment facility, that to the best of my knowledge, the above-described waste material was managed in compliance with all applicable laws, regulations, permits and licenses on the date listed above.



CWMNW RECORDS DEPARTMENT

Date: 10/04/13



CHEMICAL WASTE MANAGEMENT OF THE NW

17629 Cedar Springs Lane
Arlington, OR 97812
(541) 454-2643
(541) 454-3279 Fax

PORT OF TACOMA
WAD001882984
3400 TAYLOR WAY
TAOMA WA 98421

CERTIFICATE OF DISPOSAL

Chemical Waste Management of the Northwest, Inc., ORD089452353, has received the following waste material:

GENERATOR: PORT OF TACOMA
MANIFEST #: 010585434JJK
CWM TRACKING ID: 42874201
PROFILE #: OR321468
LINE ITEM: 9b.1
QUANTITY: 1 DT
RECEIVED DATE: 09/30/13

DISPOSAL PROCESS(ES): LANDFILL
FINAL DISPOSAL LOCATION: LANDFILL 13
DISPOSAL DATE: 09/30/13

I certify, on behalf of the above listed treatment facility, that to the best of my knowledge, the above-described waste material was managed in compliance with all applicable laws, regulations, permits and licenses on the date listed above.

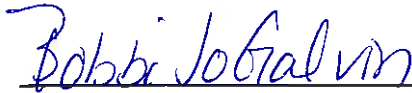

CWMNW RECORDS DEPARTMENT

Date: 10/04/13



CHEMICAL WASTE MANAGEMENT OF THE NW

17629 Cedar Springs Lane
Arlington, OR 97812
(541) 454-2643
(541) 454-3279 Fax

PORT OF TACOMA
WAD001882984
3400 TAYLOR WAY
TAOMA WA 98421

CERTIFICATE OF DISPOSAL

Chemical Waste Management of the Northwest, Inc., ORD089452353, has received the following waste material:

GENERATOR:	PORT OF TACOMA
MANIFEST #:	010585436JJK
CWM TRACKING ID:	42874001
PROFILE #:	OR321468
LINE ITEM:	9b.1
QUANTITY:	1 DT
RECEIVED DATE:	09/30/13
DISPOSAL PROCESS(ES):	LANDFILL
FINAL DISPOSAL LOCATION:	LANDFILL 13
DISPOSAL DATE:	09/30/13

I certify, on behalf of the above listed treatment facility, that to the best of my knowledge, the above-described waste material was managed in compliance with all applicable laws, regulations, permits and licenses on the date listed above.

Bobbi Jo Galvin

CWMNW RECORDS DEPARTMENT

Date: 10/04/13



CHEMICAL WASTE MANAGEMENT OF THE NW

17629 Cedar Springs Lane
Arlington, OR 97812
(541) 454-2643
(541) 454-3279 Fax

PORT OF TACOMA
WAD001882984
3400 TAYLOR WAY
TAOMA WA 98421

CERTIFICATE OF DISPOSAL

Chemical Waste Management of the Northwest, Inc., ORD089452353, has received the following waste material:

GENERATOR:	PORT OF TACOMA
MANIFEST #:	010585437JJK
CWM TRACKING ID:	42873701
PROFILE #:	OR321468
LINE ITEM:	9b.1
QUANTITY:	1 DT
RECEIVED DATE:	09/30/13
DISPOSAL PROCESS(ES):	LANDFILL
FINAL DISPOSAL LOCATION:	LANDFILL 13
DISPOSAL DATE:	09/30/13

I certify, on behalf of the above listed treatment facility, that to the best of my knowledge, the above-described waste material was managed in compliance with all applicable laws, regulations, permits and licenses on the date listed above.



CWMNW RECORDS DEPARTMENT

Date: 10/04/13



CHEMICAL WASTE MANAGEMENT OF THE NW
17629 Cedar Springs Lane
Arlington, OR 97812
(541) 454-2643
(541) 454-3279 Fax

PORT OF TACOMA
WAD001882984
3400 TAYLOR WAY
TAOMA WA 98421

CERTIFICATE OF DISPOSAL

Chemical Waste Management of the Northwest, Inc., ORD089452353, has received the following waste material:

GENERATOR:	PORT OF TACOMA
MANIFEST #:	010385432JJK
CWM TRACKING ID:	42873601
PROFILE #:	OR321468
LINE ITEM:	9b.1
QUANTITY:	1 DT
RECEIVED DATE:	09/30/13
DISPOSAL PROCESS(ES):	LANDFILL
FINAL DISPOSAL LOCATION:	LANDFILL 13
DISPOSAL DATE:	09/30/13

I certify, on behalf of the above listed treatment facility, that to the best of my knowledge, the above-described waste material was managed in compliance with all applicable laws, regulations, permits and licenses on the date listed above.

Robbi Jofalun

CWMNW RECORDS DEPARTMENT

Date: 10/04/13





CHEMICAL WASTE MANAGEMENT OF THE NW

17629 Cedar Springs Lane
Arlington, OR 97812
(541) 454-2643
(541) 454-3279 Fax

PORT OF TACOMA
WAD001882984
3400 TAYLOR WAY
TAOMA WA 98421

CERTIFICATE OF DISPOSAL

Chemical Waste Management of the Northwest, Inc., ORD089452353, has received the following waste material:

GENERATOR:	PORT OF TACOMA
MANIFEST #:	010585431JJK
CWM TRACKING ID:	42873501
PROFILE #:	OR321468
LINE ITEM:	9b.1
QUANTITY:	1 DT
RECEIVED DATE:	09/30/13
DISPOSAL PROCESS(ES):	LANDFILL
FINAL DISPOSAL LOCATION:	LANDFILL 13
DISPOSAL DATE:	09/30/13

I certify, on behalf of the above listed treatment facility, that to the best of my knowledge, the above-described waste material was managed in compliance with all applicable laws, regulations, permits and licenses on the date listed above.



CWMNW RECORDS DEPARTMENT

Date: 10/04/13



CHEMICAL WASTE MANAGEMENT OF THE NW

17629 Cedar Springs Lane
Arlington, OR 97812
(541) 454-2643
(541) 454-3279 Fax

PORT OF TACOMA
WAD001882984
3400 TAYLOR WAY
TACOMA WA 98421

CERTIFICATE OF DISPOSAL

Chemical Waste Management of the Northwest, Inc., ORD089452353, has received the following waste material:

GENERATOR:	PORT OF TACOMA
MANIFEST #:	011886520JJK
CWM TRACKING ID:	42881901
PROFILE #:	OR321468
LINE ITEM:	9b.1,
QUANTITY:	1 DT
RECEIVED DATE:	10/01/13
DISPOSAL PROCESS(ES):	LANDFILL
FINAL DISPOSAL LOCATION:	LANDFILL 13
DISPOSAL DATE:	10/01/13

I certify, on behalf of the above listed treatment facility, that to the best of my knowledge, the above-described waste material was managed in compliance with all applicable laws, regulations, permits and licenses on the date listed above.



CWMNW RECORDS DEPARTMENT

Date: 10/07/13



CHEMICAL WASTE MANAGEMENT OF THE NW
17629 Cedar Springs Lane
Arlington, OR 97812
(541) 454-2643
(541) 454-3279 Fax

PORT OF TACOMA
WAD001882984
3400 TAYLOR WAY
TACOMA WA 98421

CERTIFICATE OF DISPOSAL

Chemical Waste Management of the Northwest, Inc., ORD089452353, has received the following waste material:

GENERATOR: PORT OF TACOMA
MANIFEST #: 011886797JJK
CWM TRACKING ID: 42881701
PROFILE #: OR321468
LINE ITEM: 9b.1
QUANTITY: 1 DT
RECEIVED DATE: 10/01/13

DISPOSAL PROCESS(ES): LANDFILL
FINAL DISPOSAL LOCATION: LANDFILL 13
DISPOSAL DATE: 10/01/13

I certify, on behalf of the above listed treatment facility, that to the best of my knowledge, the above-described waste material was managed in compliance with all applicable laws, regulations, permits and licenses on the date listed above.

CWMNW RECORDS DEPARTMENT

Date: 10/07/13



CHEMICAL WASTE MANAGEMENT OF THE NW

17629 Cedar Springs Lane
Arlington, OR 97812
(541) 454-2643
(541) 454-3279 Fax

PORT OF TACOMA
WAD001882984
3400 TAYLOR WAY
TACOMA WA 98421

CERTIFICATE OF DISPOSAL

Chemical Waste Management of the Northwest, Inc., ORD089452353, has received the following waste material:

GENERATOR:	PORT OF TACOMA
MANIFEST #:	011886798JJK
CWM TRACKING ID:	42881501
PROFILE #:	OR321468
LINE ITEM:	9b.1
QUANTITY:	1 DT
RECEIVED DATE:	10/01/13
DISPOSAL PROCESS(ES):	LANDFILL
FINAL DISPOSAL LOCATION:	LANDFILL 13
DISPOSAL DATE:	10/01/13

I certify, on behalf of the above listed treatment facility, that to the best of my knowledge, the above-described waste material was managed in compliance with all applicable laws, regulations, permits and licenses on the date listed above.

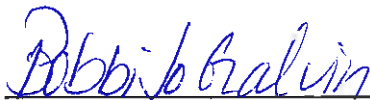

CWMNW RECORDS DEPARTMENT

Date: 10/07/13





CHEMICAL WASTE MANAGEMENT OF THE NW
17629 Cedar Springs Lane
Arlington, OR 97812
(541) 454-2643
(541) 454-3279 Fax

PORT OF TACOMA
WAD001882984
3400 TAYLOR WAY
TACOMA WA 98421

CERTIFICATE OF DISPOSAL

Chemical Waste Management of the Northwest, Inc., ORD089452353, has received the following waste material:

GENERATOR: PORT OF TACOMA
MANIFEST #: 011886517JJK
CWM TRACKING ID: 42881301
PROFILE #: OR321468
LINE ITEM: 9b.1
QUANTITY: 1 DT
RECEIVED DATE: 10/01/13

DISPOSAL PROCESS(ES): LANDFILL
FINAL DISPOSAL LOCATION: LANDFILL 13
DISPOSAL DATE: 10/01/13

I certify, on behalf of the above listed treatment facility, that to the best of my knowledge, the above-described waste material was managed in compliance with all applicable laws, regulations, permits and licenses on the date listed above.

CWMNW RECORDS DEPARTMENT

Date: 10/07/13





CHEMICAL WASTE MANAGEMENT OF THE NW

17629 Cedar Springs Lane
Arlington, OR 97812
(541) 454-2643
(541) 454-3279 Fax

PORT OF TACOMA
WAD001882984
3400 TAYLOR WAY
TACOMA WA 98421

CERTIFICATE OF DISPOSAL

Chemical Waste Management of the Northwest, Inc., ORD089452353, has received the following waste material:

GENERATOR:	PORT OF TACOMA
MANIFEST #:	011886507JJK
CWM TRACKING ID:	42831201
PROFILE #:	OR321468
LINE ITEM:	9b.1
QUANTITY:	1 DT
RECEIVED DATE:	10/01/13
DISPOSAL PROCESS(ES):	LANDFILL
FINAL DISPOSAL LOCATION:	LANDFILL 13
DISPOSAL DATE:	10/01/13

I certify, on behalf of the above listed treatment facility, that to the best of my knowledge, the above-described waste material was managed in compliance with all applicable laws, regulations, permits and licenses on the date listed above.

Bobbi Jo Galvin

CWMNW RECORDS DEPARTMENT

Date: 10/07/13



CHEMICAL WASTE MANAGEMENT OF THE NW
17629 Cedar Springs Lane
Arlington, OR 97812
(541) 454-2643
(541) 454-3279 Fax

PORT OF TACOMA
WAD001882984
3400 TAYLOR WAY
TACOMA WA 98421

CERTIFICATE OF DISPOSAL

Chemical Waste Management of the Northwest, Inc., ORD089452353, has received the following waste material:

GENERATOR: PORT OF TACOMA
MANIFEST #: 011886521JJK
CWM TRACKING ID: 42881001
PROFILE #: OR321468
LINE ITEM: 9b.1
QUANTITY: 1 DT
RECEIVED DATE: 10/01/13

DISPOSAL PROCESS(ES): LANDFILL
FINAL DISPOSAL LOCATION: LANDFILL 13
DISPOSAL DATE: 10/01/13

I certify, on behalf of the above listed treatment facility, that to the best of my knowledge, the above-described waste material was managed in compliance with all applicable laws, regulations, permits and licenses on the date listed above.

CWMNW RECORDS DEPARTMENT

Date: 10/07/13



CHEMICAL WASTE MANAGEMENT OF THE NW

17629 Cedar Springs Lane
Arlington, OR 97812
(541) 454-2643
(541) 454-3279 Fax

PORT OF TACOMA
WAD001882984
3400 TAYLOR WAY
TACOMA WA 98421

CERTIFICATE OF DISPOSAL

Chemical Waste Management of the Northwest, Inc., ORD089452353, has received the following waste material:

GENERATOR:	PORT OF TACOMA
MANIFEST #:	011886522JJK
CWM TRACKING ID:	42880901
PROFILE #:	OR:21468
LINE ITEM:	9b.1
QUANTITY:	1 DT
RECEIVED DATE:	10/01/13
DISPOSAL PROCESS(ES):	LANDFILL
FINAL DISPOSAL LOCATION:	LANDFILL 13
DISPOSAL DATE:	10/01/13

I certify, on behalf of the above listed treatment facility, that to the best of my knowledge, the above-described waste material was managed in compliance with all applicable laws, regulations, permits and licenses on the date listed above.

CWMNW RECORDS DEPARTMENT

Date: 10/07/13



CHEMICAL WASTE MANAGEMENT OF THE NW
17629 Cedar Springs Lane
Arlington, OR 97812
(541) 454-2643
(541) 454-3279 Fax

PORT OF TACOMA
WAD001882984
3400 TAYLOR WAY
TACOMA WA 98421

CERTIFICATE OF DISPOSAL

Chemical Waste Management of the Northwest, Inc., ORD089452353, has received the following waste material:

GENERATOR: PORT OF TACOMA
MANIFEST #: 011886519JJK
CWM TRACKING ID: 42880701
PROFILE #: OR321468
LINE ITEM: 9b.1
QUANTITY: 1 DT
RECEIVED DATE: 10/01/13

DISPOSAL PROCESS(ES): LANDFILL
FINAL DISPOSAL LOCATION: LANDFILL 13
DISPOSAL DATE: 10/01/13

I certify, on behalf of the above listed treatment facility, that to the best of my knowledge, the above-described waste material was managed in compliance with all applicable laws, regulations, permits and licenses on the date listed above.

Bobbi J. Galvin

CWMNW RECORDS DEPARTMENT

Date: 10/07/13



CHEMICAL WASTE MANAGEMENT OF THE NW
17629 Cedar Springs Lane
Arlington, OR 97812
(541) 454-2643
(541) 454-3279 Fax

PORT OF TACOMA
WAD001882984
3400 TAYLOR WAY
TACOMA WA 98421

CERTIFICATE OF DISPOSAL

Chemical Waste Management of the Northwest, Inc., ORD089452353, has received the following waste material:

GENERATOR:	PORT OF TACOMA
MANIFEST #:	011886518JJK
CWM TRACKING ID:	42880601
PROFILE #:	OR:21468
LINE ITEM:	9b.1
QUANTITY:	1 DT
RECEIVED DATE:	10/01/13
DISPOSAL PROCESS(ES):	LANDFILL
FINAL DISPOSAL LOCATION:	LANDFILL 13
DISPOSAL DATE:	10/01/13

I certify, on behalf of the above listed treatment facility, that to the best of my knowledge, the above-described waste material was managed in compliance with all applicable laws, regulations, permits and licenses on the date listed above.

Robbin Galvin

CWMNW RECORDS DEPARTMENT

Date: 10/07/13



CHEMICAL WASTE MANAGEMENT OF THE NW
17629 Cedar Springs Lane
Arlington, OR 97812
(541) 454-2643
(541) 454-3279 Fax

PORT OF TACOMA
WAD001882984
3400 TAYLOR WAY
TACOMA WA 98421

CERTIFICATE OF DISPOSAL

Chemical Waste Management of the Northwest, Inc., ORD089452353, has received the following waste material:

GENERATOR:	PORT OF TACOMA
MANIFEST #:	011886508JJK
CWM TRACKING ID:	42880401
PROFILE #:	OR321468
LINE ITEM:	9b.1
QUANTITY:	1 DT
RECEIVED DATE:	10/01/13
DISPOSAL PROCESS(ES):	LANDFILL
FINAL DISPOSAL LOCATION:	LANDFILL 13
DISPOSAL DATE:	10/01/13

I certify, on behalf of the above listed treatment facility, that to the best of my knowledge, the above-described waste material was managed in compliance with all applicable laws, regulations, permits and licenses on the date listed above.



CWMNW RECORDS DEPARTMENT
Date: 10/07/13



CHEMICAL WASTE MANAGEMENT OF THE NW
17629 Cedar Springs Lane
Arlington, OR 97812
(541) 454-2643
(541) 454-3279 Fax

PORT OF TACOMA
WAD001882984
3400 TAYLOR WAY
TACOMA WA 98421

CERTIFICATE OF DISPOSAL

Chemical Waste Management of the Northwest, Inc., ORD089452353, has received the following waste material:

GENERATOR:	PORT OF TACOMA
MANIFEST #:	011886502JJK
CWM TRACKING ID:	42880201
PROFILE #:	OR321468
LINE ITEM:	9b.1
QUANTITY:	1 DT
RECEIVED DATE:	10/01/13
DISPOSAL PROCESS(ES):	LANDFILL
FINAL DISPOSAL LOCATION:	LANDFILL 13
DISPOSAL DATE:	10/01/13

I certify, on behalf of the above listed treatment facility, that to the best of my knowledge, the above-described waste material was managed in compliance with all applicable laws, regulations, permits and licenses on the date listed above.

CWMNW RECORDS DEPARTMENT

Date: 10/07/13



CHEMICAL WASTE MANAGEMENT OF THE NW

17629 Cedar Springs Lane
Arlington, OR 97812
(541) 454-2643
(541) 454-3279 Fax

PORT OF TACOMA
WAD001882984
3400 TAYLOR WAY
TACOMA WA 98421

CERTIFICATE OF DISPOSAL

Chemical Waste Management of the Northwest, Inc., ORD089452353, has received the following waste material:

GENERATOR:	PORT OF TACOMA
MANIFEST #:	010585429JJK
CWM TRACKING ID:	42880001
PROFILE #:	OR321468
LINE ITEM:	9b.1
QUANTITY:	1 DT
RECEIVED DATE:	10/01/13
DISPOSAL PROCESS(ES):	LANDFILL
FINAL DISPOSAL LOCATION:	LANDFILL 13
DISPOSAL DATE:	10/01/13

I certify, on behalf of the above listed treatment facility, that to the best of my knowledge, the above-described waste material was managed in compliance with all applicable laws, regulations, permits and licenses on the date listed above.



CWMNW RECORDS DEPARTMENT

Date: 10/07/13



CHEMICAL WASTE MANAGEMENT OF THE NW
17629 Cedar Springs Lane
Arlington, OR 97812
(541) 454-2643
(541) 454-3279 Fax

PORT OF TACOMA
WAD001882984
3400 TAYLOR WAY
TACOMA WA 98421

CERTIFICATE OF DISPOSAL

Chemical Waste Management of the Northwest, Inc., ORD089452353, has received the following waste material:

GENERATOR: PORT OF TACOMA
MANIFEST #: 010585430JJK
CWM TRACKING ID: 42879901
PROFILE #: OR321468
LINE ITEM: 9b.1
QUANTITY: 1 DT
RECEIVED DATE: 10/01/13

DISPOSAL PROCESS(ES): LANDFILL
FINAL DISPOSAL LOCATION: LANDFILL 13
DISPOSAL DATE: 10/01/13

I certify, on behalf of the above listed treatment facility, that to the best of my knowledge, the above-described waste material was managed in compliance with all applicable laws, regulations, permits and licenses on the date listed above.



CWMNW RECORDS DEPARTMENT

Date: 10/07/13



CHEMICAL WASTE MANAGEMENT OF THE NW
 17629 Cedar Springs Lane
 Arlington, OR 97812
 (541) 454-2643
 (541) 454-3279 Fax

PORT OF TACOMA
 WAD001882984
 3400 TAYLOR WAY
 TACOMA WA 98421

CERTIFICATE OF DISPOSAL

Chemical Waste Management of the Northwest, Inc., ORD089452353, has received the following waste material:

GENERATOR: PORT OF TACOMA
 MANIFEST #: 011886525JJK
 CWM TRACKING ID: 42879801
 PROFILE #: OR321468
 LINE ITEM: 9b.1
 QUANTITY: 1 DT
 RECEIVED DATE: 10/01/13

DISPOSAL PROCESS(ES): LANDFILL
 FINAL DISPOSAL LOCATION: LANDFILL 13
 DISPOSAL DATE: 10/01/13

I certify, on behalf of the above listed treatment facility, that to the best of my knowledge, the above-described waste material was managed in compliance with all applicable laws, regulations, permits and licenses on the date listed above.

Robbie Galvin _____

CWMNW RECORDS DEPARTMENT

Date: 10/07/13



CHEMICAL WASTE MANAGEMENT OF THE NW

17629 Cedar Springs Lane
Arlington, OR 97812
(541) 454-2643
(541) 454-3279 Fax

PORT OF TACOMA
WAD001882984
3400 TAYLOR WAY
TACOMA WA 98421

CERTIFICATE OF DISPOSAL

Chemical Waste Management of the Northwest, Inc., ORD089452353, has received the following waste material:

GENERATOR:	PORT OF TACOMA
MANIFEST #:	011886523JJK
CWM TRACKING ID:	42879201
PROFILE #:	OR321468
LINE ITEM:	9b.1
QUANTITY:	1 DT
RECEIVED DATE:	10/01/13
DISPOSAL PROCESS(ES):	LANDFILL
FINAL DISPOSAL LOCATION:	LANDFILL 13
DISPOSAL DATE:	10/01/13

I certify, on behalf of the above listed treatment facility, that to the best of my knowledge, the above-described waste material was managed in compliance with all applicable laws, regulations, permits and licenses on the date listed above.

Bobbi Sohalvin

CWMNW RECORDS DEPARTMENT
Date: 10/07/13



CHEMICAL WASTE MANAGEMENT OF THE NW

17629 Cedar Springs Lane
Arlington, OR 97812
(541) 454-2643
(541) 454-3279 Fax

PORT OF TACOMA
WAD001882984
3400 TAYLOR WAY
TACOMA WA 98421

CERTIFICATE OF DISPOSAL

Chemical Waste Management of the Northwest, Inc., ORD089452353, has received the following waste material:

GENERATOR: PORT OF TACOMA
MANIFEST #: 010585428JJK
CWM TRACKING ID: 42879001
PROFILE #: OR321468
LINE ITEM: 9b.1
QUANTITY: 1 DT
RECEIVED DATE: 10/01/13

DISPOSAL PROCESS(ES): LANDFILL
FINAL DISPOSAL LOCATION: LANDFILL 13
DISPOSAL DATE: 10/01/13

I certify, on behalf of the above listed treatment facility, that to the best of my knowledge, the above-described waste material was managed in compliance with all applicable laws, regulations, permits and licenses on the date listed above.



CWMNW RECORDS DEPARTMENT

Date: 10/07/13



CHEMICAL WASTE MANAGEMENT OF THE NW
17629 Cedar Springs Lane
Arlington, OR 97812
(541) 454-2643
(541) 454-3279 Fax

PORT OF TACOMA
WAD001882984
3400 TAYLOR WAY
TACOMA WA 98421

CERTIFICATE OF DISPOSAL

Chemical Waste Management of the Northwest, Inc., ORD089452353, has received the following waste material:

GENERATOR: PORT OF TACOMA
MANIFEST #: 011886504JJK
CWM TRACKING ID: 428,8901
PROFILE #: OR321468
LINE ITEM: 9b.1
QUANTITY: 1 DT
RECEIVED DATE: 10/01/13

DISPOSAL PROCESS(ES): LANDFILL
FINAL DISPOSAL LOCATION: LANDFILL 13
DISPOSAL DATE: 10/01/13

I certify, on behalf of the above listed treatment facility, that to the best of my knowledge, the above-described waste material was managed in compliance with all applicable laws, regulations, permits and licenses on the date listed above.



CWMNW RECORDS DEPARTMENT

Date: 10/07/13



CHEMICAL WASTE MANAGEMENT OF THE NW

17629 Cedar Springs Lane
Arlington, OR 97812
(541) 454-2643
(541) 454-3279 Fax

PORT OF TACOMA
WAD001882984
3400 TAYLOR WAY
TACOMA WA 98421

CERTIFICATE OF DISPOSAL

Chemical Waste Management of the Northwest, Inc., ORD089452353, has received the following waste material:

GENERATOR:	PORT OF TACOMA
MANIFEST #:	011886524JJK
CWM TRACKING ID:	42878801
PROFILE #:	OR321468
LINE ITEM:	9b.1
QUANTITY:	1 DT
RECEIVED DATE:	10/01/13
DISPOSAL PROCESS(ES):	LANDFILL
FINAL DISPOSAL LOCATION:	LANDFILL 13
DISPOSAL DATE:	10/01/13

I certify, on behalf of the above listed treatment facility, that to the best of my knowledge, the above-described waste material was managed in compliance with all applicable laws, regulations, permits and licenses on the date listed above.

Robbi Jo Galvin

CWMNW RECORDS DEPARTMENT

Date: 10/07/13





CHEMICAL WASTE MANAGEMENT OF THE NW
17629 Cedar Springs Lane
Arlington, OR 97812
(541) 454-2643
(541) 454-3279 Fax

PORT OF TACOMA
WAD001882984
3400 TAYLOR WAY
TACOMA WA 98421

CERTIFICATE OF DISPOSAL

Chemical Waste Management of the Northwest, Inc., ORD089452353, has received the following waste material:

GENERATOR:	PORT OF TACOMA
MANIFEST #:	010585427JJK
CWM TRACKING ID:	42878701
PROFILE #:	OR321468
LINE ITEM:	9b.1
QUANTITY:	1 DT
RECEIVED DATE:	10/01/13
DISPOSAL PROCESS(ES):	LANDFILL
FINAL DISPOSAL LOCATION:	LANDFILL 13
DISPOSAL DATE:	10/01/13

I certify, on behalf of the above listed treatment facility, that to the best of my knowledge, the above-described waste material was managed in compliance with all applicable laws, regulations, permits and licenses on the date listed above.

Bobbi Jo Balvin

CWMNW RECORDS DEPARTMENT

Date: 10/07/13



CHEMICAL WASTE MANAGEMENT OF THE NW

17629 Cedar Springs Lane
Arlington, OR 97812
(541) 454-2643
(541) 454-3279 Fax

PORT OF TACOMA
WAD001882984
3400 TAYLOR WAY
TACOMA WA 98421

CERTIFICATE OF DISPOSAL

Chemical Waste Management of the Northwest, Inc., ORD089452353, has received the following waste material:

GENERATOR:	PORT OF TACOMA
MANIFEST #:	011886503JJK
CWM TRACKING ID:	428/8501
PROFILE #:	OR321468
LINE ITEM:	9b.1
QUANTITY:	1 DT
RECEIVED DATE:	10/01/13
DISPOSAL PROCESS(ES):	LANDFILL
FINAL DISPOSAL LOCATION:	LANDFILL 13
DISPOSAL DATE:	10/01/13

I certify, on behalf of the above listed treatment facility, that to the best of my knowledge, the above-described waste material was managed in compliance with all applicable laws, regulations, permits and licenses on the date listed above.

CWMNW RECORDS DEPARTMENT

Date: 10/07/13



CHEMICAL WASTE MANAGEMENT OF THE NW
17629 Cedar Springs Lane
Arlington, OR 97812
(541) 454-2643
(541) 454-3279 Fax

PORT OF TACOMA
WAD001882984
3400 TAYLOR WAY
TACOMA WA 98421

CERTIFICATE OF DISPOSAL

Chemical Waste Management of the Northwest, Inc., ORD089452353, has received the following waste material:

GENERATOR:	PORT OF TACOMA
MANIFEST #:	011886501JJK
CWM TRACKING ID:	42878401
PROFILE #:	OR321468
LINE ITEM:	9b.1
QUANTITY:	1 DT
RECEIVED DATE:	10/01/13
DISPOSAL PROCESS(ES):	LANDFILL
FINAL DISPOSAL LOCATION:	LANDFILL 13
DISPOSAL DATE:	10/01/13

I certify, on behalf of the above listed treatment facility, that to the best of my knowledge, the above-described waste material was managed in compliance with all applicable laws, regulations, permits and licenses on the date listed above.

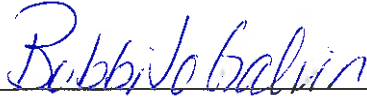

CWMNW RECORDS DEPARTMENT

Date: 10/07/13



CHEMICAL WASTE MANAGEMENT OF THE NW

17629 Cedar Springs Lane
Arlington, OR 97812
(541) 454-2643
(541) 454-3279 Fax

PORT OF TACOMA
WAD001882984
3400 TAYLOR WAY
TACOMA WA 98421

CERTIFICATE OF DISPOSAL

Chemical Waste Management of the Northwest, Inc., ORD089452353, has received the following waste material:

GENERATOR:	PORT OF TACOMA
MANIFEST #:	011886506JJK
CWM TRACKING ID:	42878301
PROFILE #:	OR321468
LINE ITEM:	9b.1
QUANTITY:	1 DT
RECEIVED DATE:	10/01/13
DISPOSAL PROCESS(ES):	LANDFILL
FINAL DISPOSAL LOCATION:	LANDFILL 13
DISPOSAL DATE:	10/01/13

I certify, on behalf of the above listed treatment facility, that to the best of my knowledge, the above-described waste material was managed in compliance with all applicable laws, regulations, permits and licenses on the date listed above.

CWMNW RECORDS DEPARTMENT

Date: 10/07/13



CHEMICAL WASTE MANAGEMENT OF THE NW
17629 Cedar Springs Lane
Arlington, OR 97812
(541) 454-2643
(541) 454-3279 Fax

PORT OF TACOMA
WAD001882984
3400 TAYLOR WAY
TACOMA WA 98421

CERTIFICATE OF DISPOSAL

Chemical Waste Management of the Northwest, Inc., ORD089452353, has received the following waste material:

GENERATOR:	PORT OF TACOMA
MANIFEST #:	011886527JJK
CWM TRACKING ID:	42887901
PROFILE #:	OR321468
LINE ITEM:	9b.1
QUANTITY:	1 DT
RECEIVED DATE:	10/02/13
DISPOSAL PROCESS(ES):	LANDFILL
FINAL DISPOSAL LOCATION:	LANDFILL 13
DISPOSAL DATE:	10/02/13

I certify, on behalf of the above listed treatment facility, that to the best of my knowledge, the above-described waste material was managed in compliance with all applicable laws, regulations, permits and licenses on the date listed above.

Bobbi Jo Galvin

CWMNW RECORDS DEPARTMENT

Date: 10/04/13



CHEMICAL WASTE MANAGEMENT OF THE NW

17629 Cedar Springs Lane
Arlington, OR 97812
(541) 454-2643
(541) 454-3279 Fax

PORT OF TACOMA
WAD001882984
3400 TAYLOR WAY
TACOMA WA 98421

CERTIFICATE OF DISPOSAL

Chemical Waste Management of the Northwest, Inc., ORD089452353, has received the following waste material:

GENERATOR: PORT OF TACOMA
MANIFEST #: 011886535JJK
CWM TRACKING ID: 42887601
PROFILE #: OR321468
LINE ITEM: 9b.1
QUANTITY: 1 DT
RECEIVED DATE: 10/02/13

DISPOSAL PROCESS(ES): LANDFILL
FINAL DISPOSAL LOCATION: LANDFILL 13
DISPOSAL DATE: 10/02/13

I certify, on behalf of the above listed treatment facility, that to the best of my knowledge, the above-described waste material was managed in compliance with all applicable laws, regulations, permits and licenses on the date listed above.



CWMNW RECORDS DEPARTMENT

Date: 10/04/13



CHEMICAL WASTE MANAGEMENT OF THE NW

17629 Cedar Springs Lane
Arlington, OR 97812
(541) 454-2643
(541) 454-3279 Fax

PORT OF TACOMA
WAD001882984
3400 TAYLOR WAY
TACOMA WA 98421

CERTIFICATE OF DISPOSAL

Chemical Waste Management of the Northwest, Inc., ORD089452353, has received the following waste material:

GENERATOR:	PORT OF TACOMA
MANIFEST #:	011886559JJK
CWM TRACKING ID:	42887501
PROFILE #:	OR321468
LINE ITEM:	9b.1
QUANTITY:	1 DT
RECEIVED DATE:	10/02/13
DISPOSAL PROCESS(ES):	LANDFILL
FINAL DISPOSAL LOCATION:	LANDFILL 13
DISPOSAL DATE:	10/02/13

I certify, on behalf of the above listed treatment facility, that to the best of my knowledge, the above-described waste material was managed in compliance with all applicable laws, regulations, permits and licenses on the date listed above.



CWMNW RECORDS DEPARTMENT

Date: 10/04/13



CHEMICAL WASTE MANAGEMENT OF THE NW

17629 Cedar Springs Lane
Arlington, OR 97812
(541) 454-2643
(541) 454-3279 Fax

PORT OF TACOMA
WAD001882984
3400 TAYLOR WAY
TACOMA WA 98421

CERTIFICATE OF DISPOSAL

Chemical Waste Management of the Northwest, Inc., ORD089452353, has received the following waste material:

GENERATOR:	PORT OF TACOMA
MANIFEST #:	011886534JJK
CWM TRACKING ID:	42887401
PROFILE #:	OR321468
LINE ITEM:	9b.1
QUANTITY:	1 DT
RECEIVED DATE:	10/02/13
DISPOSAL PROCESS(ES):	LANDFILL
FINAL DISPOSAL LOCATION:	LANDFILL 13
DISPOSAL DATE:	10/02/13

I certify, on behalf of the above listed treatment facility, that to the best of my knowledge, the above-described waste material was managed in compliance with all applicable laws, regulations, permits and licenses on the date listed above.



CWMNW RECORDS DEPARTMENT

Date: 10/04/13



CHEMICAL WASTE MANAGEMENT OF THE NW

17629 Cedar Springs Lane
Arlington, OR 97812
(541) 454-2643
(541) 454-3279 Fax

PORT OF TACOMA
WAD001882984
3400 TAYLOR WAY
TACOMA WA 98421

CERTIFICATE OF DISPOSAL

Chemical Waste Management of the Northwest, Inc., ORD089452353, has received the following waste material:

GENERATOR:	PORT OF TACOMA
MANIFEST #:	011886541JJK
CWM TRACKING ID:	42887101
PROFILE #:	OR321468
LINE ITEM:	9b.1
QUANTITY:	1 DT
RECEIVED DATE:	10/02/13
DISPOSAL PROCESS(ES):	LANDFILL
FINAL DISPOSAL LOCATION:	LANDFILL 13
DISPOSAL DATE:	10/02/13

I certify, on behalf of the above listed treatment facility, that to the best of my knowledge, the above-described waste material was managed in compliance with all applicable laws, regulations, permits and licenses on the date listed above.



CWMNW RECORDS DEPARTMENT

Date: 10/04/13



CHEMICAL WASTE MANAGEMENT OF THE NW

17629 Cedar Springs Lane
Arlington, OR 97812
(541) 454-2643
(541) 454-3279 Fax

PORT OF TACOMA
WAD001882984
3400 TAYLOR WAY
TACOMA WA 98421

CERTIFICATE OF DISPOSAL

Chemical Waste Management of the Northwest, Inc., ORD089452353, has received the following waste material:

GENERATOR: PORT OF TACOMA
MANIFEST #: 011886532JJK
CWM TRACKING ID: 42886801
PROFILE #: OR321468
LINE ITEM: 9b.1
QUANTITY: 1 DT
RECEIVED DATE: 10/02/13

DISPOSAL PROCESS(ES): LANDFILL
FINAL DISPOSAL LOCATION: LANDFILL 13
DISPOSAL DATE: 10/02/13

I certify, on behalf of the above listed treatment facility, that to the best of my knowledge, the above-described waste material was managed in compliance with all applicable laws, regulations, permits and licenses on the date listed above.

Bobbi Jo Galvin

CWMNW RECORDS DEPARTMENT

Date: 10/04/13



CHEMICAL WASTE MANAGEMENT OF THE NW

17629 Cedar Springs Lane
Arlington, OR 97812
(541) 454-2643
(541) 454-3279 Fax

PORT OF TACOMA
WAD001882984
3400 TAYLOR WAY
TACOMA WA 98421

CERTIFICATE OF DISPOSAL

Chemical Waste Management of the Northwest, Inc., ORD089452353, has received the following waste material:

GENERATOR:	PORT OF TACOMA	
MANIFEST #:	011886536JJK	
CWM TRACKING ID:	42886701	
PROFILE #:	OR321468	
LINE ITEM:	9b.1	
QUANTITY:	1 DT	
RECEIVED DATE:	10/02/13	
DISPOSAL PROCESS(ES):	LANDFILL	
FINAL DISPOSAL LOCATION:	LANDFILL	13
DISPOSAL DATE:	10/02/13	

I certify, on behalf of the above listed treatment facility, that to the best of my knowledge, the above-described waste material was managed in compliance with all applicable laws, regulations, permits and licenses on the date listed above.

Bobbi Jo Galvin

CWMNW RECORDS DEPARTMENT

Date: 10/04/13



CHEMICAL WASTE MANAGEMENT OF THE NW

17629 Cedar Springs Lane
Arlington, OR 97812
(541) 454-2643
(541) 454-3279 Fax

PORT OF TACOMA
WAD001882984
3400 TAYLOR WAY
TACOMA WA 98421

CERTIFICATE OF DISPOSAL

Chemical Waste Management of the Northwest, Inc., ORD089452353, has received the following waste material:

GENERATOR: PORT OF TACOMA
MANIFEST #: 011886537JJK
CWM TRACKING ID: 42886601
PROFILE #: OR321468
LINE ITEM: 9b.1
QUANTITY: 1 DT
RECEIVED DATE: 10/02/13

DISPOSAL PROCESS(ES): LANDFILL
FINAL DISPOSAL LOCATION: LANDFILL 13
DISPOSAL DATE: 10/02/13

I certify, on behalf of the above listed treatment facility, that to the best of my knowledge, the above-described waste material was managed in compliance with all applicable laws, regulations, permits and licenses on the date listed above.



CWMNW RECORDS DEPARTMENT

Date: 10/04/13



CHEMICAL WASTE MANAGEMENT OF THE NW

17629 Cedar Springs Lane
Arlington, OR 97812
(541) 454-2643
(541) 454-3279 Fax

PORT OF TACOMA
WAD001882984
3400 TAYLOR WAY
TACOMA WA 98421

CERTIFICATE OF DISPOSAL

Chemical Waste Management of the Northwest, Inc., ORD089452353, has received the following waste material:

GENERATOR: PORT OF TACOMA
MANIFEST #: 011886546JJK
CWM TRACKING ID: 42886501
PROFILE #: OR321468
LINE ITEM: 9b.1
QUANTITY: 1 DT
RECEIVED DATE: 10/02/13

DISPOSAL PROCESS(ES): LANDFILL
FINAL DISPOSAL LOCATION: LANDFILL 13
DISPOSAL DATE: 10/02/13

I certify, on behalf of the above listed treatment facility, that to the best of my knowledge, the above-described waste material was managed in compliance with all applicable laws, regulations, permits and licenses on the date listed above.

Robbie Galvin

CWMNW RECORDS DEPARTMENT

Date: 10/04/13





CHEMICAL WASTE MANAGEMENT OF THE NW

17629 Cedar Springs Lane
Arlington, OR 97812
(541) 454-2643
(541) 454-3279 Fax

PORT OF TACOMA
WAD001882984
3400 TAYLOR WAY
TACOMA WA 98421

CERTIFICATE OF DISPOSAL

Chemical Waste Management of the Northwest, Inc., ORD089452353, has received the following waste material:

GENERATOR: PORT OF TACOMA
MANIFEST #: 011886544JJK
CWM TRACKING ID: 42886301
PROFILE #: OR321468
LINE ITEM: 9b.1
QUANTITY: 1 DT
RECEIVED DATE: 10/02/13

DISPOSAL PROCESS(ES): LANDFILL
FINAL DISPOSAL LOCATION: LANDFILL 13
DISPOSAL DATE: 10/02/13

I certify, on behalf of the above listed treatment facility, that to the best of my knowledge, the above-described waste material was managed in compliance with all applicable laws, regulations, permits and licenses on the date listed above.

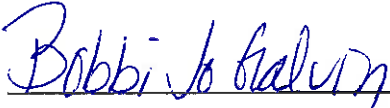

CWMNW RECORDS DEPARTMENT

Date: 10/04/13



CHEMICAL WASTE MANAGEMENT OF THE NW
17629 Cedar Springs Lane
Arlington, OR 97812
(541) 454-2643
(541) 454-3279 Fax

PORT OF TACOMA
WAD001882984
3400 TAYLOR WAY
TACOMA WA 98421

CERTIFICATE OF DISPOSAL

Chemical Waste Management of the Northwest, Inc., ORD089452353, has received the following waste material:

GENERATOR: PORT OF TACOMA
MANIFEST #: 011886538JJK
CWM TRACKING ID: 42886201
PROFILE #: OR321468
LINE ITEM: 9b.1
QUANTITY: 1 DT
RECEIVED DATE: 10/02/13

DISPOSAL PROCESS(ES): LANDFILL
FINAL DISPOSAL LOCATION: LANDFILL 13
DISPOSAL DATE: 10/02/13

I certify, on behalf of the above listed treatment facility, that to the best of my knowledge, the above-described waste material was managed in compliance with all applicable laws, regulations, permits and licenses on the date listed above.



CWMNW RECORDS DEPARTMENT

Date: 10/04/13



CHEMICAL WASTE MANAGEMENT OF THE NW

17629 Cedar Springs Lane
Arlington, OR 97812
(541) 454-2643
(541) 454-3279 Fax

PORT OF TACOMA
WAD001882984
3400 TAYLOR WAY
TACOMA WA 98421

CERTIFICATE OF DISPOSAL

Chemical Waste Management of the Northwest, Inc., ORD089452353, has received the following waste material:

GENERATOR: PORT OF TACOMA
MANIFEST #: 011886539JJK
CWM TRACKING ID: 42885901
PROFILE #: OR321468
LINE ITEM: 9b.1
QUANTITY: 1 DT
RECEIVED DATE: 10/02/13

DISPOSAL PROCESS(ES): LANDFILL
FINAL DISPOSAL LOCATION: LANDFILL 13
DISPOSAL DATE: 10/02/13

I certify, on behalf of the above listed treatment facility, that to the best of my knowledge, the above-described waste material was managed in compliance with all applicable laws, regulations, permits and licenses on the date listed above.

CWMNW RECORDS DEPARTMENT

Date: 10/04/13



CHEMICAL WASTE MANAGEMENT OF THE NW

17629 Cedar Springs Lane
Arlington, OR 97812
(541) 454-2643
(541) 454-3279 Fax

PORT OF TACOMA
WAD001882984
3400 TAYLOR WAY
TACOMA WA 98421

CERTIFICATE OF DISPOSAL

Chemical Waste Management of the Northwest, Inc., ORD089452353, has received the following waste material:

GENERATOR: PORT OF TACOMA
MANIFEST #: 011886542JJK
CWM TRACKING ID: 42885801
PROFILE #: OR321468
LINE ITEM: 9b.1
QUANTITY: 1 DT
RECEIVED DATE: 10/02/13

DISPOSAL PROCESS(ES): LANDFILL
FINAL DISPOSAL LOCATION: LANDFILL 13
DISPOSAL DATE: 10/02/13

I certify, on behalf of the above listed treatment facility, that to the best of my knowledge, the above-described waste material was managed in compliance with all applicable laws, regulations, permits and licenses on the date listed above.



CWMNW RECORDS DEPARTMENT

Date: 10/04/13



CHEMICAL WASTE MANAGEMENT OF THE NW

17629 Cedar Springs Lane
Arlington, OR 97812
(541) 454-2643
(541) 454-3279 Fax

PORT OF TACOMA
WAD001882984
3400 TAYLOR WAY
TACOMA WA 98421

CERTIFICATE OF DISPOSAL

Chemical Waste Management of the Northwest, Inc., ORD089452353, has received the following waste material:

GENERATOR:	PORT OF TACOMA
MANIFEST #:	011886540JJK
CWM TRACKING ID:	42885701
PROFILE #:	OR321468
LINE ITEM:	9b.1
QUANTITY:	1 DT
RECEIVED DATE:	10/02/13
DISPOSAL PROCESS(ES):	LANDFILL
FINAL DISPOSAL LOCATION:	LANDFILL 13
DISPOSAL DATE:	10/02/13

I certify, on behalf of the above listed treatment facility, that to the best of my knowledge, the above-described waste material was managed in compliance with all applicable laws, regulations, permits and licenses on the date listed above.



CWMNW RECORDS DEPARTMENT

Date: 10/04/13



CHEMICAL WASTE MANAGEMENT OF THE NW

17629 Cedar Springs Lane
Arlington, OR 97812
(541) 454-2643
(541) 454-3279 Fax

PORT OF TACOMA
WAD001882984
3400 TAYLOR WAY
TACOMA WA 98421

CERTIFICATE OF DISPOSAL

Chemical Waste Management of the Northwest, Inc., ORD089452353, has received the following waste material:

GENERATOR:	PORT OF TACOMA
MANIFEST #:	011886548JJK
CWM TRACKING ID:	42885601
PROFILE #:	OR321468
LINE ITEM:	9b.1
QUANTITY:	1 DT
RECEIVED DATE:	10/02/13
DISPOSAL PROCESS(ES):	LANDFILL
FINAL DISPOSAL LOCATION:	LANDFILL 13
DISPOSAL DATE:	10/02/13

I certify, on behalf of the above listed treatment facility, that to the best of my knowledge, the above-described waste material was managed in compliance with all applicable laws, regulations, permits and licenses on the date listed above.

Robbi Galvin

CWMNW RECORDS DEPARTMENT

Date: 10/04/13



CHEMICAL WASTE MANAGEMENT OF THE NW
 17629 Cedar Springs Lane
 Arlington, OR 97812
 (541) 454-2643
 (541) 454-3279 Fax

PORT OF TACOMA
 WAD001882984
 3400 TAYLOR WAY
 TACOMA WA 98421

CERTIFICATE OF DISPOSAL

Chemical Waste Management of the Northwest, Inc., ORD089452353, has received the following waste material:

GENERATOR:	PORT OF TACOMA	
MANIFEST #:	011886543JJK	
CWM TRACKING ID:	42885401	
PROFILE #:	OR321468	
LINE ITEM:	9b.1	
QUANTITY:	1 DT	
RECEIVED DATE:	10/02/13	
DISPOSAL PROCESS(ES):	LANDFILL	
FINAL DISPOSAL LOCATION:	LANDFILL	13
DISPOSAL DATE:	10/02/13	

I certify, on behalf of the above listed treatment facility, that to the best of my knowledge, the above-described waste material was managed in compliance with all applicable laws, regulations, permits and licenses on the date listed above.

Bobbi Jo Galvin _____

CWMNW RECORDS DEPARTMENT
 Date: 10/04/13



CHEMICAL WASTE MANAGEMENT OF THE NW

17629 Cedar Springs Lane
Arlington, OR 97812
(541) 454-2643
(541) 454-3279 Fax

PORT OF TACOMA
WAD001882984
3400 TAYLOR WAY
TACOMA WA 98421

CERTIFICATE OF DISPOSAL

Chemical Waste Management of the Northwest, Inc., ORD089452353, has received the following waste material:

GENERATOR: PORT OF TACOMA
MANIFEST #: 011886531JJK
CWM TRACKING ID: 42885301
PROFILE #: OR321468
LINE ITEM: 9b.1
QUANTITY: 1 DT
RECEIVED DATE: 10/02/13

DISPOSAL PROCESS(ES): LANDFILL
FINAL DISPOSAL LOCATION: LANDFILL 13
DISPOSAL DATE: 10/02/13

I certify, on behalf of the above listed treatment facility, that to the best of my knowledge, the above-described waste material was managed in compliance with all applicable laws, regulations, permits and licenses on the date listed above.

Bobbi J. Talin

CWMNW RECORDS DEPARTMENT

Date: 10/04/13



CHEMICAL WASTE MANAGEMENT OF THE NW

17629 Cedar Springs Lane
Arlington, OR 97812
(541) 454-2643
(541) 454-3279 Fax

PORT OF TACOMA
WAD001882984
3400 TAYLOR WAY
TACOMA WA 98421

CERTIFICATE OF DISPOSAL

Chemical Waste Management of the Northwest, Inc., ORD089452353, has received the following waste material:

GENERATOR: PORT OF TACOMA
MANIFEST #: 011886529JJK
CWM TRACKING ID: 42865201
PROFILE #: OR321468
LINE ITEM: 9b.1
QUANTITY: 1 DT
RECEIVED DATE: 10/02/13

DISPOSAL PROCESS(ES): LANDFILL
FINAL DISPOSAL LOCATION: LANDFILL 13
DISPOSAL DATE: 10/02/13

I certify, on behalf of the above listed treatment facility, that to the best of my knowledge, the above-described waste material was managed in compliance with all applicable laws, regulations, permits and licenses on the date listed above.

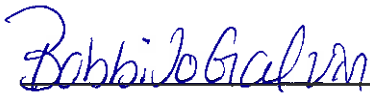

CWMNW RECORDS DEPARTMENT

Date: 10/04/13



CHEMICAL WASTE MANAGEMENT OF THE NW

17629 Cedar Springs Lane
Arlington, OR 97812
(541) 454-2643
(541) 454-3279 Fax

PORT OF TACOMA
WAD001882984
3400 TAYLOR WAY
TACOMA WA 98421

CERTIFICATE OF DISPOSAL

Chemical Waste Management of the Northwest, Inc., ORD089452353, has received the following waste material:

GENERATOR: PORT OF TACOMA
MANIFEST #: 011886528JJK
CWM TRACKING ID: 42885101
PROFILE #: OR321468
LINE ITEM: 9b.1
QUANTITY: 1 DT
RECEIVED DATE: 10/02/13

DISPOSAL PROCESS(ES): LANDFILL
FINAL DISPOSAL LOCATION: LANDFILL 13
DISPOSAL DATE: 10/02/13

I certify, on behalf of the above listed treatment facility, that to the best of my knowledge, the above-described waste material was managed in compliance with all applicable laws, regulations, permits and licenses on the date listed above.

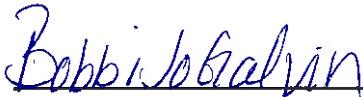

CWMNW RECORDS DEPARTMENT

Date: 10/04/13



CHEMICAL WASTE MANAGEMENT OF THE NW
17629 Cedar Springs Lane
Arlington, OR 97812
(541) 454-2643
(541) 454-3279 Fax

PORT OF TACOMA
WAD001882984
3400 TAYLOR WAY
TACOMA WA 98421

CERTIFICATE OF DISPOSAL

Chemical Waste Management of the Northwest, Inc., ORD089452353, has received the following waste material:

GENERATOR: PORT OF TACOMA
MANIFEST #: 011886530JJK
CWM TRACKING ID: 42885001
PROFILE #: OR321468
LINE ITEM: 9b.1
QUANTITY: 1 DT
RECEIVED DATE: 10/02/13

DISPOSAL PROCESS(ES): LANDFILL
FINAL DISPOSAL LOCATION: LANDFILL 13
DISPOSAL DATE: 10/02/13

I certify, on behalf of the above listed treatment facility, that to the best of my knowledge, the above-described waste material was managed in compliance with all applicable laws, regulations, permits and licenses on the date listed above.

CWMNW RECORDS DEPARTMENT

Date: 10/04/13



CHEMICAL WASTE MANAGEMENT OF THE NW

17629 Cedar Springs Lane
Arlington, OR 97812
(541) 454-2643
(541) 454-3279 Fax

PORT OF TACOMA
WAD001882984
3400 TAYLOR WAY
TACOMA WA 98421

CERTIFICATE OF DISPOSAL

Chemical Waste Management of the Northwest, Inc., ORD089452353, has received the following waste material:

GENERATOR: PORT OF TACOMA
MANIFEST #: 011886549JJK
CWM TRACKING ID: 42884901
PROFILE #: OR321468
LINE ITEM: 9b.1
QUANTITY: 1 DT
RECEIVED DATE: 10/02/13

DISPOSAL PROCESS(ES): LANDFILL
FINAL DISPOSAL LOCATION: LANDFILL 13
DISPOSAL DATE: 10/02/13

I certify, on behalf of the above listed treatment facility, that to the best of my knowledge, the above-described waste material was managed in compliance with all applicable laws, regulations, permits and licenses on the date listed above.

CWMNW RECORDS DEPARTMENT

Date: 10/04/13





CHEMICAL WASTE MANAGEMENT OF THE NW
17629 Cedar Springs Lane
Arlington, OR 97812
(541) 454-2643
(541) 454-3279 Fax

PORT OF TACOMA
WAD001882984
3400 TAYLOR WAY
TACOMA WA 98421

CERTIFICATE OF DISPOSAL

Chemical Waste Management of the Northwest, Inc., ORD089452353, has received the following waste material:

GENERATOR: PORT OF TACOMA
MANIFEST #: 011886547JJK
CWM TRACKING ID: 42884801
PROFILE #: OR321468
LINE ITEM: 9b.1
QUANTITY: 1 DT
RECEIVED DATE: 10/02/13

DISPOSAL PROCESS(ES): LANDFILL
FINAL DISPOSAL LOCATION: LANDFILL 13
DISPOSAL DATE: 10/02/13

I certify, on behalf of the above listed treatment facility, that to the best of my knowledge, the above-described waste material was managed in compliance with all applicable laws, regulations, permits and licenses on the date listed above.

CWMNW RECORDS DEPARTMENT

Date: 10/04/13



CHEMICAL WASTE MANAGEMENT OF THE NW

17629 Cedar Springs Lane
Arlington, OR 97812
(541) 454-2643
(541) 454-3279 Fax

PORT OF TACOMA
WAD001882984
3400 TAYLOR WAY
TACOMA WA 98421

CERTIFICATE OF DISPOSAL

Chemical Waste Management of the Northwest, Inc., ORD089452353, has received the following waste material:

GENERATOR: PORT OF TACOMA
MANIFEST #: 011886533JJK
CWM TRACKING ID: 42884301
PROFILE #: OR321468
LINE ITEM: 9b.1
QUANTITY: 1 DT
RECEIVED DATE: 10/02/13

DISPOSAL PROCESS(ES): LANDFILL
FINAL DISPOSAL LOCATION: LANDFILL 13
DISPOSAL DATE: 10/02/13

I certify, on behalf of the above listed treatment facility, that to the best of my knowledge, the above-described waste material was managed in compliance with all applicable laws, regulations, permits and licenses on the date listed above.

Robbi Jobalvin

CWMNW RECORDS DEPARTMENT

Date: 10/04/13



CHEMICAL WASTE MANAGEMENT OF THE N

17629 Cedar Springs Lane
Arlington, OR 97812
(541) 454-2643
(541) 454-3279 Fax

PORT OF TACOMA
WAD001882984
3400 TAYLOR WAY
TACOMA WA 98421

CERTIFICATE OF DISPOSAL

Chemical Waste Management of the Northwest, Inc., ORD089452353, has received the following waste material:

GENERATOR:	PORT OF TACOMA
MANIFEST #:	011886545JJK
CWM TRACKING ID:	42886001
PROFILE #:	OR321468
LINE ITEM:	9b.1
QUANTITY:	1 DT
RECEIVED DATE:	10/02/13
DISPOSAL PROCESS(ES):	LANDFILL
FINAL DISPOSAL LOCATION:	LANDFILL 13
DISPOSAL DATE:	10/02/13

I certify, on behalf of the above listed treatment facility, that to the best of my knowledge, the above-described waste material was managed in compliance with all applicable laws, regulations, permits and licenses on the date listed above.

Robbie Balvin

CWMNW RECORDS DEPARTMENT

Date: 10/10/13



CHEMICAL WASTE MANAGEMENT OF THE NW

17629 Cedar Springs Lane
Arlington, OR 97812
(541) 454-2643
(541) 454-3279 Fax

PORT OF TACOMA
WAD001882984
3400 TAYLOR WAY
TACOMA WA 98421

CERTIFICATE OF DISPOSAL

Chemical Waste Management of the Northwest, Inc., ORD089452353, has received the following waste material:

GENERATOR: PORT OF TACOMA
MANIFEST #: 011886516JJK
CWM TRACKING ID: 42889401
PROFILE #: OR321468
LINE ITEM: 9b.1
QUANTITY: 1 DT
RECEIVED DATE: 10/03/13

DISPOSAL PROCESS(ES): LANDFILL
FINAL DISPOSAL LOCATION: LANDFILL 14
DISPOSAL DATE: 10/03/13

I certify, on behalf of the above listed treatment facility, that to the best of my knowledge, the above-described waste material was managed in compliance with all applicable laws, regulations, permits and licenses on the date listed above.



CWMNW RECORDS DEPARTMENT

Date: 10/10/13



CHEMICAL WASTE MANAGEMENT OF THE NW

17629 Cedar Springs Lane
Arlington, OR 97812
541 454 2643

PORT OF TACOMA
WAD001882984
3400 TAYLOR WAY
TACOMA WA 98421

CERTIFICATE OF DISPOSAL

Chemical Waste Management of the Northwest, Inc., ORD089452353, has received the following waste material:

GENERATOR: PORT OF TACOMA
MANIFEST #: 011886576JJK
CWM TRACKING ID: 42891401
PROFILE #: OR32468
LINE ITEM: 9b.1
QUANTITY: 1 DT
RECEIVED DATE: 10/03/13

DISPOSAL PROCESS(ES): LANDFILL
FINAL DISPOSAL LOCATION: LANDFILL 13
DISPOSAL DATE: 10/03/13

I certify, on behalf of the above listed treatment facility, that to the best of my knowledge, the above-described waste material was managed in compliance with all applicable laws, regulations, permits and licenses on the date listed above.



CWMNW RECORDS DEPARTMENT

Date: 10/10/13



CHEMICAL WASTE MANAGEMENT OF THE NW

17629 Cedar Springs Lane
Arlington, OR 97812
541 454 2643

PORT OF TACOMA
WAD001882984
3400 TAYLOR WAY
TACOMA WA 98421

CERTIFICATE OF DISPOSAL

Chemical Waste Management of the Northwest, Inc., ORD089452353, has received the following waste material:

GENERATOR:	PORT OF TACOMA
MANIFEST #:	011886550JJK
CWM TRACKING ID:	42893101
PROFILE #:	OR321468
LINE ITEM:	9b.1
QUANTITY:	1 DT
RECEIVED DATE:	10/03/13
DISPOSAL PROCESS(ES):	LANDFILL
FINAL DISPOSAL LOCATION:	LANDFILL 13
DISPOSAL DATE:	10/03/13

I certify, on behalf of the above listed treatment facility, that to the best of my knowledge, the above-described waste material was managed in compliance with all applicable laws, regulations, permits and licenses on the date listed above.

Bobbie Galvin

CWMNW RECORDS DEPARTMENT

Date: 10/14/13



CHEMICAL WASTE MANAGEMENT OF THE NW

17629 Cedar Springs Lane
Arlington, OR 97812
(541) 454-2643
(541) 454-3279 Fax

PORT OF TACOMA
WAD001882984
3400 TAYLOR WAY
TACOMA WA 98421

CERTIFICATE OF DISPOSAL

Chemical Waste Management of the Northwest, Inc., ORD089452353, has received the following waste material:

GENERATOR:	PORT OF TACOMA
MANIFEST #:	011086573JJK
CWM TRACKING ID:	42890801
PROFILE #:	OR321468
LINE ITEM:	9b.1
QUANTITY:	1 DT
RECEIVED DATE:	10/03/13
DISPOSAL PROCESS(ES):	LANDFILL
FINAL DISPOSAL LOCATION:	LANDFILL 13
DISPOSAL DATE:	10/03/13

I certify, on behalf of the above listed treatment facility, that to the best of my knowledge, the above-described waste material was managed in compliance with all applicable laws, regulations, permits and licenses on the date listed above.

Bobbi Jobalvin

CWMNW RECORDS DEPARTMENT

Date: 10/10/13



CHEMICAL WASTE MANAGEMENT OF THE NW

17629 Cedar Springs Lane
Arlington, OR 97812
(541) 454-2643
(541) 454-3279 Fax

PORT OF TACOMA
WAD001882984
3400 TAYLOR WAY
TACOMA WA 98421

CERTIFICATE OF DISPOSAL

Chemical Waste Management of the Northwest, Inc., ORD089452353, has received the following waste material:

GENERATOR:	PORT OF TACOMA
MANIFEST #:	011886578JJK
CWM TRACKING ID:	42891101
PROFILE #:	OR321468
LINE ITEM:	9b.1
QUANTITY:	1 DT
RECEIVED DATE:	10/03/13
DISPOSAL PROCESS(ES):	LANDFILL
FINAL DISPOSAL LOCATION:	LANDFILL 13
DISPOSAL DATE:	10/03/13

I certify, on behalf of the above listed treatment facility, that to the best of my knowledge, the above-described waste material was managed in compliance with all applicable laws, regulations, permits and licenses on the date listed above.



CWMNW RECORDS DEPARTMENT

Date: 10/10/13



CHEMICAL WASTE MANAGEMENT OF THE NW

17629 Cedar Springs Lane
Arlington, OR 97812
(541) 454-2643
(541) 454-3279 Fax

PORT OF TACOMA
WAD001882984
3400 TAYLOR WAY
TACOMA WA 98421

CERTIFICATE OF DISPOSAL

Chemical Waste Management of the Northwest, Inc., ORD089452353, has received the following waste material:

GENERATOR: PORT OF TACOMA
MANIFEST #: 011886574JJK
CWM TRACKING ID: 42891301
PROFILE #: OR321468
LINE ITEM: 9b.1
QUANTITY: 1 DT
RECEIVED DATE: 10/03/13

DISPOSAL PROCESS(ES): LANDFILL
FINAL DISPOSAL LOCATION: LANDFILL 13
DISPOSAL DATE: 10/03/13

I certify, on behalf of the above listed treatment facility, that to the best of my knowledge, the above-described waste material was managed in compliance with all applicable laws, regulations, permits and licenses on the date listed above.

CWMNW RECORDS DEPARTMENT

Date: 10/10/13



CHEMICAL WASTE MANAGEMENT OF THE NW

17629 Cedar Springs Lane
Arlington, OR 97812
(541) 454-2643
(541) 454-3279 Fax

PORT OF TACOMA
WAD001882984
3400 TAYLOR WAY
TACOMA WA 98421

CERTIFICATE OF DISPOSAL

Chemical Waste Management of the Northwest, Inc., ORD089452353, has received the following waste material:

GENERATOR:	PORT OF TACOMA
MANIFEST #:	011886572JJK
CWM TRACKING ID:	42891501
PROFILE #:	OR321468
LINE ITEM:	9b.1
QUANTITY:	1 DT
RECEIVED DATE:	10/03/13
DISPOSAL PROCESS(ES):	LANDFILL
FINAL DISPOSAL LOCATION:	LANDFILL 13
DISPOSAL DATE:	10/03/13

I certify, on behalf of the above listed treatment facility, that to the best of my knowledge, the above-described waste material was managed in compliance with all applicable laws, regulations, permits and licenses on the date listed above.

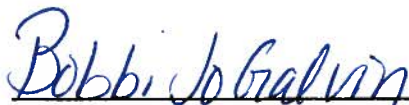

CWMNW RECORDS DEPARTMENT

Date: 10/10/13



CHEMICAL WASTE MANAGEMENT OF THE NW

17629 Cedar Springs Lane
Arlington, OR 97812
(541) 454-2643
(541) 454-3279 Fax

PORT OF TACOMA
WAD001882984
3400 TAYLOR WAY
TACOMA WA 98421

CERTIFICATE OF DISPOSAL

Chemical Waste Management of the Northwest, Inc., ORD089452353, has received the following waste material:

GENERATOR:	PORT OF TACOMA
MANIFEST #:	011886561JJK
CWM TRACKING ID:	42891701
PROFILE #:	OR321468
LINE ITEM:	9b.1
QUANTITY:	1 DT
RECEIVED DATE:	10/03/13
DISPOSAL PROCESS(ES):	LANDFILL
FINAL DISPOSAL LOCATION:	LANDFILL 13
DISPOSAL DATE:	10/03/13

I certify, on behalf of the above listed treatment facility, that to the best of my knowledge, the above-described waste material was managed in compliance with all applicable laws, regulations, permits and licenses on the date listed above.



CWMNW RECORDS DEPARTMENT

Date: 10/10/13



CHEMICAL WASTE MANAGEMENT OF THE NW

17629 Cedar Springs Lane
Arlington, OR 97812
541 454 2643

PORT OF TACOMA
WAD001882984
3400 TAYLOR WAY
TACOMA WA 98421

CERTIFICATE OF DISPOSAL

Chemical Waste Management of the Northwest, Inc., ORD089452353, has received the following waste material:

GENERATOR:	PORT OF TACOMA
MANIFEST #:	011886577JJK
CWM TRACKING ID:	42891901
PROFILE #:	OR321468
LINE ITEM:	9b.1
QUANTITY:	1 DT
RECEIVED DATE:	10/03/13
DISPOSAL PROCESS(ES):	LANDFILL
FINAL DISPOSAL LOCATION:	LANDFILL 13
DISPOSAL DATE:	10/03/13

I certify, on behalf of the above listed treatment facility, that to the best of my knowledge, the above-described waste material was managed in compliance with all applicable laws, regulations, permits and licenses on the date listed above.

Bobbi Jobalvin

CWMNW RECORDS DEPARTMENT

Date: 10/10/13



CHEMICAL WASTE MANAGEMENT OF THE NW

17629 Cedar Springs Lane
Arlington, OR 97812
(541) 454-2643
(541) 454-3279 Fax

PORT OF TACOMA
WAD001882984
3400 TAYLOR WAY
TACOMA WA 98421

CERTIFICATE OF DISPOSAL

Chemical Waste Management of the Northwest, Inc., ORD089452353, has received the following waste material:

GENERATOR:	PORT OF TACOMA
MANIFEST #:	011886557JJK
CWM TRACKING ID:	42890401
PROFILE #:	OR:21468
LINE ITEM:	9b.1
QUANTITY:	1 DT
RECEIVED DATE:	10/03/13
DISPOSAL PROCESS(ES):	LANDFILL
FINAL DISPOSAL LOCATION:	LANDFILL 13
DISPOSAL DATE:	10/03/13

I certify, on behalf of the above listed treatment facility, that to the best of my knowledge, the above-described waste material was managed in compliance with all applicable laws, regulations, permits and licenses on the date listed above.

Bobbi Jo Galvin

CWMNW RECORDS DEPARTMENT

Date: 10/10/13



CHEMICAL WASTE MANAGEMENT OF THE NW

17629 Cedar Springs Lane
Arlington, OR 97812
(541) 454-2643
(541) 454-3279 Fax

PORT OF TACOMA
WAD001882984
3400 TAYLOR WAY
TACOMA WA 98421

CERTIFICATE OF DISPOSAL

Chemical Waste Management of the Northwest, Inc., ORD089452353, has received the following waste material:

GENERATOR:	PORT OF TACOMA
MANIFEST #:	011886558JJK
CWM TRACKING ID:	42890501
PROFILE #:	OR321468
LINE ITEM:	9b.1
QUANTITY:	1 DT
RECEIVED DATE:	10/03/13
DISPOSAL PROCESS(ES):	LANDFILL
FINAL DISPOSAL LOCATION:	LANDFILL 13
DISPOSAL DATE:	10/03/13

I certify, on behalf of the above listed treatment facility, that to the best of my knowledge, the above-described waste material was managed in compliance with all applicable laws, regulations, permits and licenses on the date listed above.

Robbi Jobalvin

CWMNW RECORDS DEPARTMENT

Date: 10/10/13



CHEMICAL WASTE MANAGEMENT OF THE NW

17629 Cedar Springs Lane
Arlington, OR 97812
(541) 454-2643
(541) 454-3279 Fax

PORT OF TACOMA
WAD001882984
3400 TAYLOR WAY
TACOMA WA 98421

CERTIFICATE OF DISPOSAL

Chemical Waste Management of the Northwest, Inc., ORD089452353, has received the following waste material:

GENERATOR:	PORT OF TACOMA
MANIFEST #:	011886575JJK
CWM TRACKING ID:	42890601
PROFILE #:	OR321468
LINE ITEM:	9b.1
QUANTITY:	1 DT
RECEIVED DATE:	10/03/13
DISPOSAL PROCESS(ES):	LANDFILL
FINAL DISPOSAL LOCATION:	LANDFILL 13
DISPOSAL DATE:	10/03/13

I certify, on behalf of the above listed treatment facility, that to the best of my knowledge, the above-described waste material was managed in compliance with all applicable laws, regulations, permits and licenses on the date listed above.

Robb Jo Galvin

CWMNW RECORDS DEPARTMENT

Date: 10/10/13



CHEMICAL WASTE MANAGEMENT OF THE NW

17629 Cedar Springs Lane
Arlington, OR 97812
(541) 454-2643
(541) 454-3279 Fax

PORT OF TACOMA
WAD001882984
3400 TAYLOR WAY
TACOMA WA 98421

CERTIFICATE OF DISPOSAL

Chemical Waste Management of the Northwest, Inc., ORD089452353, has received the following waste material:

GENERATOR:	PORT OF TACOMA
MANIFEST #:	011886571JJK
CWM TRACKING ID:	42890701
PROFILE #:	OR321468
LINE ITEM:	9b.1
QUANTITY:	1 DT
RECEIVED DATE:	10/03/13
DISPOSAL PROCESS(ES):	LANDFILL
FINAL DISPOSAL LOCATION:	LANDFILL 13
DISPOSAL DATE:	10/03/13

I certify, on behalf of the above listed treatment facility, that to the best of my knowledge, the above-described waste material was managed in compliance with all applicable laws, regulations, permits and licenses on the date listed above.

Robbink Galvin

CWMNW RECORDS DEPARTMENT

Date: 10/10/13



CHEMICAL WASTE MANAGEMENT OF THE NW

17629 Cedar Springs Lane
Arlington, OR 97812
541 454 2643

PORT OF TACOMA
WAD001882984
3400 TAYLOR WAY
TACOMA WA 98421

CERTIFICATE OF DISPOSAL

Chemical Waste Management of the Northwest, Inc., ORD089452353, has received the following waste material:

GENERATOR:	PORT OF TACOMA
MANIFEST #:	011886560JJK
CWM TRACKING ID:	42892001
PROFILE #:	OR321468
LINE ITEM:	9b.1
QUANTITY:	1 DT
RECEIVED DATE:	10/03/13
DISPOSAL PROCESS(ES):	LANDFILL
FINAL DISPOSAL LOCATION:	LANDFILL 13
DISPOSAL DATE:	10/03/13

I certify, on behalf of the above listed treatment facility, that to the best of my knowledge, the above-described waste material was managed in compliance with all applicable laws, regulations, permits and licenses on the date listed above.

Robbi Jobalvin

CWMNW RECORDS DEPARTMENT

Date: 10/10/13



CHEMICAL WASTE MANAGEMENT OF THE NW

17629 Cedar Springs Lane
Arlington, OR 97812
541 454 2643

PORT OF TACOMA
WAD001882984
3400 TAYLOR WAY
TACOMA WA 98421

CERTIFICATE OF DISPOSAL

Chemical Waste Management of the Northwest, Inc., ORD089452353, has received the following waste material:

GENERATOR:	PORT OF TACOMA
MANIFEST #:	011886556JJK
CWM TRACKING ID:	42892101
PROFILE #:	OR?21468
LINE ITEM:	9b.1
QUANTITY:	1 DT
RECEIVED DATE:	10/03/13
DISPOSAL PROCESS(ES):	LANDFILL
FINAL DISPOSAL LOCATION:	LANDFILL 13
DISPOSAL DATE:	10/03/13

I certify, on behalf of the above listed treatment facility, that to the best of my knowledge, the above-described waste material was managed in compliance with all applicable laws, regulations, permits and licenses on the date listed above.

Robbino Galvin

CWMNW RECORDS DEPARTMENT

Date: 10/10/13



CHEMICAL WASTE MANAGEMENT OF THE NW

17629 Cedar Springs Lane
Arlington, OR 97812
541 454 2643

PORT OF TACOMA
WAD001882984
3400 TAYLOR WAY
TACOMA WA 98421

CERTIFICATE OF DISPOSAL

Chemical Waste Management of the Northwest, Inc., ORD089452353, has received the following waste material:

GENERATOR:	PORT OF TACOMA
MANIFEST #:	011886562JJK
CWM TRACKING ID:	42892201
PROFILE #:	OR321468
LINE ITEM:	9b.1
QUANTITY:	1 DT
RECEIVED DATE:	10/03/13
DISPOSAL PROCESS(ES):	LANDFILL
FINAL DISPOSAL LOCATION:	LANDFILL 13
DISPOSAL DATE:	10/03/13

I certify, on behalf of the above listed treatment facility, that to the best of my knowledge, the above-described waste material was managed in compliance with all applicable laws, regulations, permits and licenses on the date listed above.

Bobbi Jo Galvin

CWMNW RECORDS DEPARTMENT

Date: 10/10/13



CHEMICAL WASTE MANAGEMENT OF THE NW

17629 Cedar Springs Lane
Arlington, OR 97812
541 454 2643

PORT OF TACOMA
WAD001882984
3400 TAYLOR WAY
TACOMA WA 98421

CERTIFICATE OF DISPOSAL

Chemical Waste Management of the Northwest, Inc., ORD089452353, has received the following waste material:

GENERATOR: PORT OF TACOMA
MANIFEST #: 011886555JJK
CWM TRACKING ID: 42892301
PROFILE #: OR321468
LINE ITEM: 9b.1
QUANTITY: 1 DT
RECEIVED DATE: 10/03/13

DISPOSAL PROCESS(ES): LANDFILL
FINAL DISPOSAL LOCATION: LANDFILL 13
DISPOSAL DATE: 10/03/13

I certify, on behalf of the above listed treatment facility, that to the best of my knowledge, the above-described waste material was managed in compliance with all applicable laws, regulations, permits and licenses on the date listed above.



CWMNW RECORDS DEPARTMENT

Date: 10/10/13



CHEMICAL WASTE MANAGEMENT OF THE NW

17629 Cedar Springs Lane
Arlington, OR 97812
541 454 2643

PORT OF TACOMA
WAD001882984
3400 TAYLOR WAY
TACOMA WA 98421

CERTIFICATE OF DISPOSAL

Chemical Waste Management of the Northwest, Inc., ORD089452353, has received the following waste material:

GENERATOR:	PORT OF TACOMA
MANIFEST #:	011886553JJK
CWM TRACKING ID:	42892701
PROFILE #:	OR321468
LINE ITEM:	9b.1
QUANTITY:	1 DT
RECEIVED DATE:	10/03/13
DISPOSAL PROCESS(ES):	LANDFILL
FINAL DISPOSAL LOCATION:	LANDFILL 13
DISPOSAL DATE:	10/03/13

I certify, on behalf of the above listed treatment facility, that to the best of my knowledge, the above-described waste material was managed in compliance with all applicable laws, regulations, permits and licenses on the date listed above.

Bobbi Jo Galvin

CWMNW RECORDS DEPARTMENT

Date: 10/10/13



CHEMICAL WASTE MANAGEMENT OF THE NW

17629 Cedar Springs Lane
Arlington, OR 97812
541 454 2643

PORT OF TACOMA
WAD001882984
3400 TAYLOR WAY
TACOMA WA 98421

CERTIFICATE OF DISPOSAL

Chemical Waste Management of the Northwest, Inc., ORD089452353, has received the following waste material:

GENERATOR:	PORT OF TACOMA
MANIFEST #:	011886563JJK
CWM TRACKING ID:	42893001
PROFILE #:	OR321468
LINE ITEM:	9b.1
QUANTITY:	1 DT
RECEIVED DATE:	10/03/13
DISPOSAL PROCESS(ES):	LANDFILL
FINAL DISPOSAL LOCATION:	LANDFILL 13
DISPOSAL DATE:	10/03/13

I certify, on behalf of the above listed treatment facility, that to the best of my knowledge, the above-described waste material was managed in compliance with all applicable laws, regulations, permits and licenses on the date listed above.

Bobbi Jo Galvin

CWMNW RECORDS DEPARTMENT

Date: 10/10/13



CHEMICAL WASTE MANAGEMENT OF THE NW

17629 Cedar Springs Lane
Arlington, OR 97812
541 454 2643

PORT OF TACOMA
WAD001882984
3400 TAYLOR WAY
TACOMA WA 98421

CERTIFICATE OF DISPOSAL

Chemical Waste Management of the Northwest, Inc., ORD089452353, has received the following waste material:

GENERATOR:	PORT OF TACOMA
MANIFEST #:	011886564JJK
CWM TRACKING ID:	42893201
PROFILE #:	OR321468
LINE ITEM:	9b.1
QUANTITY:	1 DT
RECEIVED DATE:	10/03/13
DISPOSAL PROCESS(ES):	LANDFILL
FINAL DISPOSAL LOCATION:	LANDFILL 13
DISPOSAL DATE:	10/03/13

I certify, on behalf of the above listed treatment facility, that to the best of my knowledge, the above-described waste material was managed in compliance with all applicable laws, regulations, permits and licenses on the date listed above.

Bobbi Jo Galvin

CWMNW RECORDS DEPARTMENT

Date: 10/10/13



CHEMICAL WASTE MANAGEMENT OF THE NW

17629 Cedar Springs Lane
Arlington, OR 97812
541 454 2643

PORT OF TACOMA
WAD001882984
3400 TAYLOR WAY
TACOMA WA 98421

CERTIFICATE OF DISPOSAL

Chemical Waste Management of the Northwest, Inc., ORD089452353, has received the following waste material:

GENERATOR:	PORT OF TACOMA
MANIFEST #:	011886554JJK
CWM TRACKING ID:	42893401
PROFILE #:	OR321468
LINE ITEM:	9b.1
QUANTITY:	1 DT
RECEIVED DATE:	10/03/13
DISPOSAL PROCESS(ES):	LANDFILL
FINAL DISPOSAL LOCATION:	LANDFILL 13
DISPOSAL DATE:	10/03/13

I certify, on behalf of the above listed treatment facility, that to the best of my knowledge, the above-described waste material was managed in compliance with all applicable laws, regulations, permits and licenses on the date listed above.

Bobbi Jo Galvin

CWMNW RECORDS DEPARTMENT

Date: 10/10/13



CHEMICAL WASTE MANAGEMENT OF THE NW

17629 Cedar Springs Lane
Arlington, OR 97812
541 454 2643

PORT OF TACOMA
WAD001882984
3400 TAYLOR WAY
TACOMA WA 98421

CERTIFICATE OF DISPOSAL

Chemical Waste Management of the Northwest, Inc., ORD089452353, has received the following waste material:

GENERATOR:	PORT OF TACOMA
MANIFEST #:	011886552JJK
CWM TRACKING ID:	42893601
PROFILE #:	OR321468
LINE ITEM:	9b.1
QUANTITY:	1 DT
RECEIVED DATE:	10/03/13
DISPOSAL PROCESS(ES):	LANDFILL
FINAL DISPOSAL LOCATION:	LANDFILL 13
DISPOSAL DATE:	10/03/13

I certify, on behalf of the above listed treatment facility, that to the best of my knowledge, the above-described waste material was managed in compliance with all applicable laws, regulations, permits and licenses on the date listed above.

Bobbi Jo Galvin

CWMNW RECORDS DEPARTMENT

Date: 10/10/13



CHEMICAL WASTE MANAGEMENT OF THE NW

17629 Cedar Springs Lane
Arlington, OR 97812
541 454 2643

PORT OF TACOMA
WAD001882984
3400 TAYLOR WAY
TACOMA WA 98421

CERTIFICATE OF DISPOSAL

Chemical Waste Management of the Northwest, Inc., ORD089452353, has received the following waste material:

GENERATOR:	PORT OF TACOMA
MANIFEST #:	011886551JJK
CWM TRACKING ID:	42893701
PROFILE #:	OR321468
LINE ITEM:	9b.1
QUANTITY:	1 DT
RECEIVED DATE:	10/03/13
DISPOSAL PROCESS(ES):	LANDFILL
FINAL DISPOSAL LOCATION:	LANDFILL 13
DISPOSAL DATE:	10/03/13

I certify, on behalf of the above listed treatment facility, that to the best of my knowledge, the above-described waste material was managed in compliance with all applicable laws, regulations, permits and licenses on the date listed above.

Robbi Jo Balvin

CWMNW RECORDS DEPARTMENT

Date: 10/10/13



CHEMICAL WASTE MANAGEMENT OF THE NW

17629 Cedar Springs Lane
Arlington, OR 97812
541 454 2643

PORT OF TACOMA
WAD001882984
3400 TAYLOR WAY
TACOMA WA 98421

CERTIFICATE OF DISPOSAL

Chemical Waste Management of the Northwest, Inc., ORD089452353, has received the following waste material:

GENERATOR:	PORT OF TACOMA
MANIFEST #:	011886565JJK
CWM TRACKING ID:	42893801
PROFILE #:	OR321468
LINE ITEM:	9b.1
QUANTITY:	1 DT
RECEIVED DATE:	10/03/13
DISPOSAL PROCESS(ES):	LANDFILL
FINAL DISPOSAL LOCATION:	LANDFILL 13
DISPOSAL DATE:	10/03/13

I certify, on behalf of the above listed treatment facility, that to the best of my knowledge, the above-described waste material was managed in compliance with all applicable laws, regulations, permits and licenses on the date listed above.

Bobbi Jo Galvin

CWMNW RECORDS DEPARTMENT

Date: 10/10/13



CHEMICAL WASTE MANAGEMENT OF THE NW

17629 Cedar Springs Lane
Arlington, OR 97812
541 454 2643

PORT OF TACOMA
WAD001882984
3400 TAYLOR WAY
TACOMA WA 98421

CERTIFICATE OF DISPOSAL

Chemical Waste Management of the Northwest, Inc., ORD089452353, has received the following waste material:

GENERATOR:	PORT OF TACOMA
MANIFEST #:	011886570JJK
CWM TRACKING ID:	42896101
PROFILE #:	OR321468
LINE ITEM:	9b.1
QUANTITY:	1 DT
RECEIVED DATE:	10/04/13
DISPOSAL PROCESS(ES):	LANDFILL
FINAL DISPOSAL LOCATION:	LANDFILL 13
DISPOSAL DATE:	10/04/13

I certify, on behalf of the above listed treatment facility, that to the best of my knowledge, the above-described waste material was managed in compliance with all applicable laws, regulations, permits and licenses on the date listed above.

Bobbi Jo Galvin

CWMNW RECORDS DEPARTMENT

Date: 10/10/13



CHEMICAL WASTE MANAGEMENT OF THE NW

17629 Cedar Springs Lane
Arlington, OR 97812
541 454 2643

PORT OF TACOMA
WAD001882984
3400 TAYLOR WAY
TACOMA WA 98421

CERTIFICATE OF DISPOSAL

Chemical Waste Management of the Northwest, Inc., ORD089452353, has received the following waste material:

GENERATOR:	PORT OF TACOMA
MANIFEST #:	011886589JJK
CWM TRACKING ID:	42869301
PROFILE #:	OR321468
LINE ITEM:	9b.1
QUANTITY:	1 DT
RECEIVED DATE:	10/04/13
DISPOSAL PROCESS(ES):	LANDFILL
FINAL DISPOSAL LOCATION:	LANDFILL 13
DISPOSAL DATE:	10/04/13

I certify, on behalf of the above listed treatment facility, that to the best of my knowledge, the above-described waste material was managed in compliance with all applicable laws, regulations, permits and licenses on the date listed above.

Bobbi Jo Galvin

CWMNW RECORDS DEPARTMENT

Date: 10/10/13



CHEMICAL WASTE MANAGEMENT OF THE NW

17629 Cedar Springs Lane
Arlington, OR 97812
541 454 2643

PORT OF TACOMA
WAD001882984
3400 TAYLOR WAY
TACOMA WA 98421

CERTIFICATE OF DISPOSAL

Chemical Waste Management of the Northwest, Inc., ORD089452353, has received the following waste material:

GENERATOR:	PORT OF TACOMA
MANIFEST #:	011886593JJK
CWM TRACKING ID:	42896401
PROFILE #:	OR321468
LINE ITEM:	9b.1
QUANTITY:	1 DT
RECEIVED DATE:	10/04/13
DISPOSAL PROCESS(ES):	LANDFILL
FINAL DISPOSAL LOCATION:	LANDFILL 13
DISPOSAL DATE:	10/04/13

I certify, on behalf of the above listed treatment facility, that to the best of my knowledge, the above-described waste material was managed in compliance with all applicable laws, regulations, permits and licenses on the date listed above.

Bobbi SoGalum

CWMNW RECORDS DEPARTMENT

Date: 10/10/13



CHEMICAL WASTE MANAGEMENT OF THE NW

17629 Cedar Springs Lane
Arlington, OR 97812
541 454 2643

PORT OF TACOMA
WAD001882984
3400 TAYLOR WAY
TACOMA WA 98421

CERTIFICATE OF DISPOSAL

Chemical Waste Management of the Northwest, Inc., ORD089452353, has received the following waste material:

GENERATOR:	PORT OF TACOMA
MANIFEST #:	011886588JJK
CWM TRACKING ID:	42869501
PROFILE #:	OR321468
LINE ITEM:	9b.1
QUANTITY:	1 DT
RECEIVED DATE:	10/04/13
DISPOSAL PROCESS(ES):	LANDFILL
FINAL DISPOSAL LOCATION:	LANDFILL 13
DISPOSAL DATE:	10/04/13

I certify, on behalf of the above listed treatment facility, that to the best of my knowledge, the above-described waste material was managed in compliance with all applicable laws, regulations, permits and licenses on the date listed above.

Bobbi Jo Galvin

CWMNW RECORDS DEPARTMENT

Date: 10/10/13



CHEMICAL WASTE MANAGEMENT OF THE NW

17629 Cedar Springs Lane
Arlington, OR 97812
541 454 2643

PORT OF TACOMA
WAD001882984
3400 TAYLOR WAY
TACOMA WA 98421

CERTIFICATE OF DISPOSAL

Chemical Waste Management of the Northwest, Inc., ORD089452353, has received the following waste material:

GENERATOR:	PORT OF TACOMA
MANIFEST #:	011886595JJK
CWM TRACKING ID:	42896601
PROFILE #:	OR321468
LINE ITEM:	9b.1
QUANTITY:	1 DT
RECEIVED DATE:	10/04/13
DISPOSAL PROCESS(ES):	LANDFILL
FINAL DISPOSAL LOCATION:	LANDFILL 13
DISPOSAL DATE:	10/04/13

I certify, on behalf of the above listed treatment facility, that to the best of my knowledge, the above-described waste material was managed in compliance with all applicable laws, regulations, permits and licenses on the date listed above.



CWMNW RECORDS DEPARTMENT

Date: 10/10/13



CHEMICAL WASTE MANAGEMENT OF THE NW

17629 Cedar Springs Lane
Arlington, OR 97812
541 454 2643

PORT OF TACOMA
WAD001882984
3400 TAYLOR WAY
TACOMA WA 98421

CERTIFICATE OF DISPOSAL

Chemical Waste Management of the Northwest, Inc., ORD089452353, has received the following waste material:

GENERATOR:	PORT OF TACOMA
MANIFEST #:	011886585JJK
CWM TRACKING ID:	42896901
PROFILE #:	OR321468
LINE ITEM:	9b.1
QUANTITY:	1 DT
RECEIVED DATE:	10/04/13
DISPOSAL PROCESS(ES):	LANDFILL
FINAL DISPOSAL LOCATION:	LANDFILL 13
DISPOSAL DATE:	10/04/13

I certify, on behalf of the above listed treatment facility, that to the best of my knowledge, the above-described waste material was managed in compliance with all applicable laws, regulations, permits and licenses on the date listed above.

Bobbi Jo Galvin

CWMNW RECORDS DEPARTMENT

Date: 10/10/13



CHEMICAL WASTE MANAGEMENT OF THE NW

17629 Cedar Springs Lane
Arlington, OR 97812
541 454 2643

PORT OF TACOMA
WAD001882984
3400 TAYLOR WAY
TACOMA WA 98421

CERTIFICATE OF DISPOSAL

Chemical Waste Management of the Northwest, Inc., ORD089452353, has received the following waste material:

GENERATOR:	PORT OF TACOMA
MANIFEST #:	011886586JJK
CWM TRACKING ID:	42897301
PROFILE #:	OR321468
LINE ITEM:	9b.1
QUANTITY:	1 D7
RECEIVED DATE:	10/04/13
DISPOSAL PROCESS(ES):	LANDFILL
FINAL DISPOSAL LOCATION:	LANDFILL 13
DISPOSAL DATE:	10/04/13

I certify, on behalf of the above listed treatment facility, that to the best of my knowledge, the above-described waste material was managed in compliance with all applicable laws, regulations, permits and licenses on the date listed above.



CWMNW RECORDS DEPARTMENT

Date: 10/10/13



CHEMICAL WASTE MANAGEMENT OF THE NW

17629 Cedar Springs Lane
Arlington, OR 97812
541 454 2643

PORT OF TACOMA
WAD001882984
3400 TAYLOR WAY
TACOMA WA 98421

CERTIFICATE OF DISPOSAL

Chemical Waste Management of the Northwest, Inc., ORD089452353, has received the following waste material:

GENERATOR:	PORT OF TACOMA
MANIFEST #:	011886583JJK
CWM TRACKING ID:	42897501
PROFILE #:	OR321468
LINE ITEM:	9b.1
QUANTITY:	1 DT
RECEIVED DATE:	10/04/13
DISPOSAL PROCESS(ES):	LANDFILL
FINAL DISPOSAL LOCATION:	LANDFILL 13
DISPOSAL DATE:	10/04/13

I certify, on behalf of the above listed treatment facility, that to the best of my knowledge, the above-described waste material was managed in compliance with all applicable laws, regulations, permits and licenses on the date listed above.



CWMNW RECORDS DEPARTMENT

Date: 10/10/13



CHEMICAL WASTE MANAGEMENT OF THE NW

17629 Cedar Springs Lane
Arlington, OR 97812
541 454 2643

PORT OF TACOMA
WAD001882984
3400 TAYLOR WAY
TACOMA WA 98421

CERTIFICATE OF DISPOSAL

Chemical Waste Management of the Northwest, Inc., ORD089452353, has received the following waste material:

GENERATOR:	PORT OF TACOMA
MANIFEST #:	011885687JJK
CWM TRACKING ID:	42897601
PROFILE #:	OR321468
LINE ITEM:	9b.1
QUANTITY:	1 DT
RECEIVED DATE:	10/04/13
DISPOSAL PROCESS(ES):	LANDFILL
FINAL DISPOSAL LOCATION:	LANDFILL 13
DISPOSAL DATE:	10/04/13

I certify, on behalf of the above listed treatment facility, that to the best of my knowledge, the above-described waste material was managed in compliance with all applicable laws, regulations, permits and licenses on the date listed above.

Robbi Jobalvin

CWMNW RECORDS DEPARTMENT

Date: 10/10/13



CHEMICAL WASTE MANAGEMENT OF THE NW

17629 Cedar Springs Lane
Arlington, OR 97812
541 454 2643

PORT OF TACOMA
WAD001882984
3400 TAYLOR WAY
TACOMA WA 98421

CERTIFICATE OF DISPOSAL

Chemical Waste Management of the Northwest, Inc., ORD089452353, has received the following waste material:

GENERATOR:	PORT OF TACOMA
MANIFEST #:	011886592JJK
CWM TRACKING ID:	42897701
PROFILE #:	OR321468
LINE ITEM:	9b.1
QUANTITY:	1 DT
RECEIVED DATE:	10/04/13
DISPOSAL PROCESS(ES):	LANDFILL
FINAL DISPOSAL LOCATION:	LANDFILL 13
DISPOSAL DATE:	10/04/13

I certify, on behalf of the above listed treatment facility, that to the best of my knowledge, the above-described waste material was managed in compliance with all applicable laws, regulations, permits and licenses on the date listed above.



CWMNW RECORDS DEPARTMENT

Date: 10/10/13



CHEMICAL WASTE MANAGEMENT OF THE NW

17629 Cedar Springs Lane
Arlington, OR 97812
541 454 2643

PORT OF TACOMA
WAD001882984
3400 TAYLOR WAY
TACOMA WA 98421

CERTIFICATE OF DISPOSAL

Chemical Waste Management of the Northwest, Inc., ORD089452353, has received the following waste material:

GENERATOR:	PORT OF TACOMA
MANIFEST #:	011886594JJK
CWM TRACKING ID:	42897801
PROFILE #:	OR321468
LINE ITEM:	9b.1
QUANTITY:	1 DT
RECEIVED DATE:	10/04/13
DISPOSAL PROCESS(ES):	LANDFILL
FINAL DISPOSAL LOCATION:	LANDFILL 13
DISPOSAL DATE:	10/04/13

I certify, on behalf of the above listed treatment facility, that to the best of my knowledge, the above-described waste material was managed in compliance with all applicable laws, regulations, permits and licenses on the date listed above.



CWMNW RECORDS DEPARTMENT

Date: 10/10/13



CHEMICAL WASTE MANAGEMENT OF THE NW

17629 Cedar Springs Lane
Arlington, OR 97812
541 454 2643

PORT OF TACOMA
WAD001882984
3400 TAYLOR WAY
TACOMA WA 98421

CERTIFICATE OF DISPOSAL

Chemical Waste Management of the Northwest, Inc., ORD089452353, has received the following waste material:

GENERATOR:	PORT OF TACOMA
MANIFEST #:	011886590JJK
CWM TRACKING ID:	42898101
PROFILE #:	OR321468
LINE ITEM:	9b.1
QUANTITY:	1 DT
RECEIVED DATE:	10/04/13
DISPOSAL PROCESS(ES):	LANDFILL
FINAL DISPOSAL LOCATION:	LANDFILL 13
DISPOSAL DATE:	10/04/13

I certify, on behalf of the above listed treatment facility, that to the best of my knowledge, the above-described waste material was managed in compliance with all applicable laws, regulations, permits and licenses on the date listed above.



CWMNW RECORDS DEPARTMENT

Date: 10/10/13



CHEMICAL WASTE MANAGEMENT OF THE NW

17629 Cedar Springs Lane
Arlington, OR 97812
541 454 2643

PORT OF TACOMA
WAD001882984
3400 TAYLOR WAY
TACOMA WA 98421

CERTIFICATE OF DISPOSAL

Chemical Waste Management of the Northwest, Inc., ORD089452353, has received the following waste material:

GENERATOR:	PORT OF TACOMA
MANIFEST #:	011886785JJK
CWM TRACKING ID:	42898201
PROFILE #:	OR321468
LINE ITEM:	9b.1
QUANTITY:	1 DT
RECEIVED DATE:	10/04/13
DISPOSAL PROCESS(ES):	LANDFILL
FINAL DISPOSAL LOCATION:	LANDFILL 13
DISPOSAL DATE:	10/04/13

I certify, on behalf of the above listed treatment facility, that to the best of my knowledge, the above-described waste material was managed in compliance with all applicable laws, regulations, permits and licenses on the date listed above.

Bobbi Sobalun

CWMNW RECORDS DEPARTMENT

Date: 10/10/13



CHEMICAL WASTE MANAGEMENT OF THE NW

17629 Cedar Springs Lane
Arlington, OR 97812
541 454 2643

PORT OF TACOMA
WAD001882984
3400 TAYLOR WAY
TACOMA WA 98421

CERTIFICATE OF DISPOSAL

Chemical Waste Management of the Northwest, Inc., ORD089452353, has received the following waste material:

GENERATOR:	PORT OF TACOMA
MANIFEST #:	011886582JJK
CWM TRACKING ID:	42898301
PROFILE #:	OR321468
LINE ITEM:	9b.1
QUANTITY:	1 DT
RECEIVED DATE:	10/04/13
DISPOSAL PROCESS(ES):	LANDFILL
FINAL DISPOSAL LOCATION:	LANDFILL 13
DISPOSAL DATE:	10/04/13

I certify, on behalf of the above listed treatment facility, that to the best of my knowledge, the above-described waste material was managed in compliance with all applicable laws, regulations, permits and licenses on the date listed above.

Bobbi Galvin

CWMNW RECORDS DEPARTMENT

Date: 10/10/13



CHEMICAL WASTE MANAGEMENT OF THE NW

17629 Cedar Springs Lane
Arlington, OR 97812
541 454 2643

PORT OF TACOMA
WAD001882984
3400 TAYLOR WAY
TACOMA WA 98421

CERTIFICATE OF DISPOSAL

Chemical Waste Management of the Northwest, Inc., ORD089452353, has received the following waste material:

GENERATOR:	PORT OF TACOMA
MANIFEST #:	011886591JJK
CWM TRACKING ID:	42898401
PROFILE #:	OR321468
LINE ITEM:	9b.1
QUANTITY:	1 DT
RECEIVED DATE:	10/04/13
DISPOSAL PROCESS(ES):	LANDFILL
FINAL DISPOSAL LOCATION:	LANDFILL 13
DISPOSAL DATE:	10/04/13

I certify, on behalf of the above listed treatment facility, that to the best of my knowledge, the above-described waste material was managed in compliance with all applicable laws, regulations, permits and licenses on the date listed above.

Robbilo Galvin

CWMNW RECORDS DEPARTMENT

Date: 10/10/13



CHEMICAL WASTE MANAGEMENT OF THE NW

17629 Cedar Springs Lane
Arlington, OR 97812
541 454 2643

PORT OF TACOMA
WAD001882984
3400 TAYLOR WAY
TACOMA WA 98421

CERTIFICATE OF DISPOSAL

Chemical Waste Management of the Northwest, Inc., ORD089452353, has received the following waste material:

GENERATOR:	PORT OF TACOMA
MANIFEST #:	011886584JJK
CWM TRACKING ID:	42898601
PROFILE #:	OR321468
LINE ITEM:	9b.1
QUANTITY:	1 DT
RECEIVED DATE:	10/04/13
DISPOSAL PROCESS(ES):	LANDFILL
FINAL DISPOSAL LOCATION:	LANDFILL 13
DISPOSAL DATE:	10/04/13

I certify, on behalf of the above listed treatment facility, that to the best of my knowledge, the above-described waste material was managed in compliance with all applicable laws, regulations, permits and licenses on the date listed above.

Robbi So Galvin

CWMNW RECORDS DEPARTMENT

Date: 10/10/13



CHEMICAL WASTE MANAGEMENT OF THE NW

17629 Cedar Springs Lane
Arlington, OR 97812
541 454 2643

PORT OF TACOMA
WAD001882984
3400 TAYLOR WAY
TACOMA WA 98421

CERTIFICATE OF DISPOSAL

Chemical Waste Management of the Northwest, Inc., ORD089452353, has received the following waste material:

GENERATOR:	PORT OF TACOMA
MANIFEST #:	011886581JJK
CWM TRACKING ID:	42898701
PROFILE #:	OR321468
LINE ITEM:	9b.1
QUANTITY:	1 DT
RECEIVED DATE:	10/04/13
DISPOSAL PROCESS(ES):	LANDFILL
FINAL DISPOSAL LOCATION:	LANDFILL 13
DISPOSAL DATE:	10/04/13

I certify, on behalf of the above listed treatment facility, that to the best of my knowledge, the above-described waste material was managed in compliance with all applicable laws, regulations, permits and licenses on the date listed above.

Bobbi Johnson

CWMNW RECORDS DEPARTMENT

Date: 10/10/13



CHEMICAL WASTE MANAGEMENT OF THE NW

17629 Cedar Springs Lane
Arlington, OR 97812
541 454 2643

PORT OF TACOMA
WAD001882984
3400 TAYLOR WAY
TACOMA WA 98421

CERTIFICATE OF DISPOSAL

Chemical Waste Management of the Northwest, Inc., ORD089452353, has received the following waste material:

GENERATOR:	PORT OF TACOMA
MANIFEST #:	011886580JJK
CWM TRACKING ID:	42898901
PROFILE #:	OR321468
LINE ITEM:	9b.1
QUANTITY:	1 DT
RECEIVED DATE:	10/04/13
DISPOSAL PROCESS(ES):	LANDFILL
FINAL DISPOSAL LOCATION:	LANDFILL 13
DISPOSAL DATE:	10/04/13

I certify, on behalf of the above listed treatment facility, that to the best of my knowledge, the above-described waste material was managed in compliance with all applicable laws, regulations, permits and licenses on the date listed above.

Bobbi Jo Galvin

CWMNW RECORDS DEPARTMENT

Date: 10/10/13



CHEMICAL WASTE MANAGEMENT OF THE NW

17629 Cedar Springs Lane
Arlington, OR 97812
541 454 2643

PORT OF TACOMA
WAD001882984
3400 TAYLOR WAY
TACOMA WA 98421

CERTIFICATE OF DISPOSAL

Chemical Waste Management of the Northwest, Inc., ORD089452353, has received the following waste material:

GENERATOR:	PORT OF TACOMA
MANIFEST #:	011886567JJK
CWM TRACKING ID:	42899001
PROFILE #:	OR321468
LINE ITEM:	9b.1
QUANTITY:	1 DT
RECEIVED DATE:	10/04/13
DISPOSAL PROCESS(ES):	LANDFILL
FINAL DISPOSAL LOCATION:	LANDFILL 13
DISPOSAL DATE:	10/04/13

I certify, on behalf of the above listed treatment facility, that to the best of my knowledge, the above-described waste material was managed in compliance with all applicable laws, regulations, permits and licenses on the date listed above.



CWMNW RECORDS DEPARTMENT

Date: 10/10/13



CHEMICAL WASTE MANAGEMENT OF THE NW

17629 Cedar Springs Lane
Arlington, OR 97812
541 454 2643

PORT OF TACOMA
WAD001882984
3400 TAYLOR WAY
TACOMA WA 98421

CERTIFICATE OF DISPOSAL

Chemical Waste Management of the Northwest, Inc., ORD089452353, has received the following waste material:

GENERATOR:	PORT OF TACOMA
MANIFEST #:	011886566JJK
CWM TRACKING ID:	42899201
PROFILE #:	OR321468
LINE ITEM:	9b.1
QUANTITY:	1 DT
RECEIVED DATE:	10/04/13

DISPOSAL PROCESS(ES):	LANDFILL	
FINAL DISPOSAL LOCATION:	LANDFILL	13
DISPOSAL DATE:	10/04/13	

I certify, on behalf of the above listed treatment facility, that to the best of my knowledge, the above-described waste material was managed in compliance with all applicable laws, regulations, permits and licenses on the date listed above.



CWMNW RECORDS DEPARTMENT

Date: 10/10/13





CHEMICAL WASTE MANAGEMENT OF THE NW

17629 Cedar Springs Lane
Arlington, OR 97812
541 454 2643

PORT OF TACOMA
WAD001882984
3400 TAYLOR WAY
TACOMA WA 98421

CERTIFICATE OF DISPOSAL

Chemical Waste Management of the Northwest, Inc., ORD089452353, has received the following waste material:

GENERATOR:	PORT OF TACOMA
MANIFEST #:	011886568JJK
CWM TRACKING ID:	42899301
PROFILE #:	OR321468
LINE ITEM:	9b.1
QUANTITY:	1 DT
RECEIVED DATE:	10/04/13
DISPOSAL PROCESS(ES):	LANDFILL
FINAL DISPOSAL LOCATION:	LANDFILL 13
DISPOSAL DATE:	10/04/13

I certify, on behalf of the above listed treatment facility, that to the best of my knowledge, the above-described waste material was managed in compliance with all applicable laws, regulations, permits and licenses on the date listed above.

Bobbi J Galvin

CWMNW RECORDS DEPARTMENT

Date: 10/10/13



CHEMICAL WASTE MANAGEMENT OF THE NW

17629 Cedar Springs Lane
Arlington, OR 97812
541 454 2643

PORT OF TACOMA
WAD001882984
3400 TAYLOR WAY
TACOMA WA 98421

CERTIFICATE OF DISPOSAL

Chemical Waste Management of the Northwest, Inc., ORD089452353, has received the following waste material:

GENERATOR:	PORT OF TACOMA
MANIFEST #:	011886569JJK
CWM TRACKING ID:	42896201
PROFILE #:	OR321468
LINE ITEM:	9b.1
QUANTITY:	1 DT
RECEIVED DATE:	10/04/13
DISPOSAL PROCESS(ES):	LANDFILL
FINAL DISPOSAL LOCATION:	LANDFILL 13
DISPOSAL DATE:	10/04/13

I certify, on behalf of the above listed treatment facility, that to the best of my knowledge, the above-described waste material was managed in compliance with all applicable laws, regulations, permits and licenses on the date listed above.

Robbi Jo Galum

CWMNW RECORDS DEPARTMENT

Date: 10/14/13



CHEMICAL WASTE MANAGEMENT OF THE NW

17629 Cedar Springs Lane
Arlington, OR 97812
541 454 2643

PORT OF TACOMA
WAD001882984
3400 TAYLOR WAY
TACOMA WA 98421

CERTIFICATE OF DISPOSAL

Chemical Waste Management of the Northwest, Inc., ORD089452353, has received the following waste material:

GENERATOR:	PORT OF TACOMA	
MANIFEST #:	011886579JJK	
CWM TRACKING ID:	42898801	
PROFILE #:	OR321468	
LINE ITEM:	9b.1	
QUANTITY:	1 DT	
RECEIVED DATE:	10/04/13	
DISPOSAL PROCESS(ES):	LANDFILL	
FINAL DISPOSAL LOCATION:	LANDFILL	13
DISPOSAL DATE:	10/04/13	

I certify, on behalf of the above listed treatment facility, that to the best of my knowledge, the above-described waste material was managed in compliance with all applicable laws, regulations, permits and licenses on the date listed above.



CWMNW RECORDS DEPARTMENT

Date: 10/10/13



CHEMICAL WASTE MANAGEMENT OF THE NW

17629 Cedar Springs Lane
Arlington, OR 97812
541 454 2643

PORT OF TACOMA
WAD001882984
3400 TAYLOR WAY
TACOMA WA 98421

CERTIFICATE OF DISPOSAL

Chemical Waste Management of the Northwest, Inc., ORD089452353, has received the following waste material:

GENERATOR:	PORT OF TACOMA
MANIFEST #:	011886775JJK
CWM TRACKING ID:	42901701
PROFILE #:	OR321468
LINE ITEM:	9b.1
QUANTITY:	1 DT
RECEIVED DATE:	10/07/13
DISPOSAL PROCESS(ES):	LANDFILL
FINAL DISPOSAL LOCATION:	LANDFILL 13
DISPOSAL DATE:	10/07/13

I certify, on behalf of the above listed treatment facility, that to the best of my knowledge, the above-described waste material was managed in compliance with all applicable laws, regulations, permits and licenses on the date listed above.

CWMNW RECORDS DEPARTMENT

Date: 10/14/13



CHEMICAL WASTE MANAGEMENT OF THE NW

17629 Cedar Springs Lane
Arlington, OR 97812
541 454 2643

PORT OF TACOMA
WAD001882984
3400 TAYLOR WAY
TACOMA WA 98421

CERTIFICATE OF DISPOSAL

Chemical Waste Management of the Northwest, Inc., ORD089452353, has received the following waste material:

GENERATOR:	PORT OF TACOMA
MANIFEST #:	011886774JJK
CWM TRACKING ID:	42901001
PROFILE #:	OR321468
LINE ITEM:	9b.1
QUANTITY:	1 DT
RECEIVED DATE:	10/07/13
DISPOSAL PROCESS(ES):	LANDFILL
FINAL DISPOSAL LOCATION:	LANDFILL 13
DISPOSAL DATE:	10/07/13

I certify, on behalf of the above listed treatment facility, that to the best of my knowledge, the above-described waste material was managed in compliance with all applicable laws, regulations, permits and licenses on the date listed above.



CWMNW RECORDS DEPARTMENT

Date: 10/14/13



CHEMICAL WASTE MANAGEMENT OF THE NW

17629 Cedar Springs Lane
Arlington, OR 97812
541 454 2643

PORT OF TACOMA
WAD001882984
3400 TAYLOR WAY
TACOMA WA 98421

CERTIFICATE OF DISPOSAL

Chemical Waste Management of the Northwest, Inc., ORD089452353, has received the following waste material:

GENERATOR:	PORT OF TACOMA
MANIFEST #:	011886794JJK
CWM TRACKING ID:	42901101
PROFILE #:	OR321468
LINE ITEM:	9b.1
QUANTITY:	1 DT
RECEIVED DATE:	10/07/13
DISPOSAL PROCESS(ES):	LANDFILL
FINAL DISPOSAL LOCATION:	LANDFILL 13
DISPOSAL DATE:	10/07/13

I certify, on behalf of the above listed treatment facility, that to the best of my knowledge, the above-described waste material was managed in compliance with all applicable laws, regulations, permits and licenses on the date listed above.



CWMNW RECORDS DEPARTMENT

Date: 10/14/13



CHEMICAL WASTE MANAGEMENT OF THE NW

17629 Cedar Springs Lane
Arlington, OR 97812
541 454 2643

PORT OF TACOMA
WAD001882984
3400 TAYLOR WAY
TACOMA WA 98421

CERTIFICATE OF DISPOSAL

Chemical Waste Management of the Northwest, Inc., ORD089452353, has received the following waste material:

GENERATOR:	PORT OF TACOMA
MANIFEST #:	011886773JJK
CWM TRACKING ID:	42901501
PROFILE #:	OR321468
LINE ITEM:	9b.1
QUANTITY:	1 DT
RECEIVED DATE:	10/07/13
DISPOSAL PROCESS(ES):	LANDFILL
FINAL DISPOSAL LOCATION:	LANDFILL 13
DISPOSAL DATE:	10/07/13

I certify, on behalf of the above listed treatment facility, that to the best of my knowledge, the above-described waste material was managed in compliance with all applicable laws, regulations, permits and licenses on the date listed above.

CWMNW RECORDS DEPARTMENT

Date: 10/14/13



CHEMICAL WASTE MANAGEMENT OF THE NW

17629 Cedar Springs Lane
Arlington, OR 97812
541 454 2643

PORT OF TACOMA
WAD001882984
3400 TAYLOR WAY
TACOMA WA 98421

CERTIFICATE OF DISPOSAL

Chemical Waste Management of the Northwest, Inc., ORD089452353, has received the following waste material:

GENERATOR:	PORT OF TACOMA
MANIFEST #:	011886792JJK
CWM TRACKING ID:	429016
PROFILE #:	OR321468
LINE ITEM:	9b.1
QUANTITY:	1 DT
RECEIVED DATE:	10/07/13
DISPOSAL PROCESS(ES):	LANDFILL
FINAL DISPOSAL LOCATION:	LANDFILL 13
DISPOSAL DATE:	10/07/13

I certify, on behalf of the above listed treatment facility, that to the best of my knowledge, the above-described waste material was managed in compliance with all applicable laws, regulations, permits and licenses on the date listed above.

Bobbi J. Galvin

CWMNW RECORDS DEPARTMENT

Date: 10/14/13



CHEMICAL WASTE MANAGEMENT OF THE NW

17629 Cedar Springs Lane
Arlington, OR 97812
541 454 2643

PORT OF TACOMA
WAD001882984
3400 TAYLOR WAY
TACOMA WA 98421

CERTIFICATE OF DISPOSAL

Chemical Waste Management of the Northwest, Inc., ORD089452353, has received the following waste material:

GENERATOR: PORT OF TACOMA
MANIFEST #: 011886795JJK
CWM TRACKING ID: 42901801
PROFILE #: OR321468
LINE ITEM: 9b.1
QUANTITY: 1 DT
RECEIVED DATE: 10/07/13

DISPOSAL PROCESS(ES): LANDFILL
FINAL DISPOSAL LOCATION: LANDFILL 13
DISPOSAL DATE: 10/07/13

I certify, on behalf of the above listed treatment facility, that to the best of my knowledge, the above-described waste material was managed in compliance with all applicable laws, regulations, permits and licenses on the date listed above.

Bobbi Sobalun

CWMNW RECORDS DEPARTMENT

Date: 10/14/13



CHEMICAL WASTE MANAGEMENT OF THE NW

17629 Cedar Springs Lane
Arlington, OR 97812
541 454 2643

PORT OF TACOMA
WAD001882984
3400 TAYLOR WAY
TACOMA WA 98421

CERTIFICATE OF DISPOSAL

Chemical Waste Management of the Northwest, Inc., ORD089452353, has received the following waste material:

GENERATOR:	PORT OF TACOMA
MANIFEST #:	011886772JJK
CWM TRACKING ID:	42901901
PROFILE #:	OR321468
LINE ITEM:	9b.1
QUANTITY:	1 DT
RECEIVED DATE:	10/07/13
DISPOSAL PROCESS(ES):	LANDFILL
FINAL DISPOSAL LOCATION:	LANDFILL 13
DISPOSAL DATE:	10/07/13

I certify, on behalf of the above listed treatment facility, that to the best of my knowledge, the above-described waste material was managed in compliance with all applicable laws, regulations, permits and licenses on the date listed above.

Bobbi Jofalvin

CWMNW RECORDS DEPARTMENT

Date: 10/14/13



CHEMICAL WASTE MANAGEMENT OF THE NW

17629 Cedar Springs Lane
Arlington, OR 97812
541 454 2643

PORT OF TACOMA
WAD001882984
3400 TAYLOR WAY
TACOMA WA 98421

CERTIFICATE OF DISPOSAL

Chemical Waste Management of the Northwest, Inc., ORD089452353, has received the following waste material:

GENERATOR:	PORT OF TACOMA
MANIFEST #:	011886796JJK
CWM TRACKING ID:	42902001
PROFILE #:	OR321468
LINE ITEM:	9b.1
QUANTITY:	1 DT
RECEIVED DATE:	10/07/13
DISPOSAL PROCESS(ES):	LANDFILL
FINAL DISPOSAL LOCATION:	LANDFILL 13
DISPOSAL DATE:	10/07/13

I certify, on behalf of the above listed treatment facility, that to the best of my knowledge, the above-described waste material was managed in compliance with all applicable laws, regulations, permits and licenses on the date listed above.

Bobbi Jofralin

CWMNW RECORDS DEPARTMENT

Date: 10/14/13



CHEMICAL WASTE MANAGEMENT OF THE NW

17629 Cedar Springs Lane
Arlington, OR 97812
541 454 2643

PORT OF TACOMA
WAD001882984
3400 TAYLOR WAY
TACOMA WA 98421

CERTIFICATE OF DISPOSAL

Chemical Waste Management of the Northwest, Inc., ORD089452353, has received the following waste material:

GENERATOR:	PORT OF TACOMA
MANIFEST #:	011886770JJK
CWM TRACKING ID:	42902201
PROFILE #:	OR321468
LINE ITEM:	9b.1
QUANTITY:	1 DT
RECEIVED DATE:	10/07/13
DISPOSAL PROCESS(ES):	LANDFILL
FINAL DISPOSAL LOCATION:	LANDFILL 13
DISPOSAL DATE:	10/07/13

I certify, on behalf of the above listed treatment facility, that to the best of my knowledge, the above-described waste material was managed in compliance with all applicable laws, regulations, permits and licenses on the date listed above.

Robbi Galvin

CWMNW RECORDS DEPARTMENT

Date: 10/14/13



CHEMICAL WASTE MANAGEMENT OF THE NW
17629 Cedar Springs Lane
Arlington, OR 97812
541 454 2643

PORT OF TACOMA
WAD001882984
3400 TAYLOR WAY
TACOMA WA 98421

CERTIFICATE OF DISPOSAL

Chemical Waste Management of the Northwest, Inc., ORD089452353, has received the following waste material:

GENERATOR:	PORT OF TACOMA
MANIFEST #:	011886771JJK
CWM TRACKING ID:	42902301
PROFILE #:	OR321468
LINE ITEM:	9b.1
QUANTITY:	1 DT
RECEIVED DATE:	10/07/13
DISPOSAL PROCESS(ES):	LANDFILL
FINAL DISPOSAL LOCATION:	LANDFILL 13
DISPOSAL DATE:	10/07/13

I certify, on behalf of the above listed treatment facility, that to the best of my knowledge, the above-described waste material was managed in compliance with all applicable laws, regulations, permits and licenses on the date listed above.



CWMNW RECORDS DEPARTMENT
Date:

10/14/13



CHEMICAL WASTE MANAGEMENT OF THE NW

17629 Cedar Springs Lane
Arlington, OR 97812
541 454 2643

PORT OF TACOMA
WAD001882984
3400 TAYLOR WAY
TACOMA WA 98421

CERTIFICATE OF DISPOSAL

Chemical Waste Management of the Northwest, Inc., ORD089452353, has received the following waste material:

GENERATOR:	PORT OF TACOMA
MANIFEST #:	011886791JJK
CWM TRACKING ID:	42902401
PROFILE #:	OR321468
LINE ITEM:	9b.1
QUANTITY:	1 DT
RECEIVED DATE:	10/07/13

DISPOSAL PROCESS(ES):	LANDFILL	
FINAL DISPOSAL LOCATION:	LANDFILL	13
DISPOSAL DATE:	10/07/13	

I certify, on behalf of the above listed treatment facility, that to the best of my knowledge, the above-described waste material was managed in compliance with all applicable laws, regulations, permits and licenses on the date listed above.



CWMNW RECORDS DEPARTMENT

Date: 10/14/13



CHEMICAL WASTE MANAGEMENT OF THE NW

17629 Cedar Springs Lane
Arlington, OR 97812
541 454 2643

PORT OF TACOMA
WAD001882984
3400 TAYLOR WAY
TACOMA WA 98421

CERTIFICATE OF DISPOSAL

Chemical Waste Management of the Northwest, Inc., ORD089452353, has received the following waste material:

GENERATOR: PORT OF TACOMA
MANIFEST #: 011886787JJK
CWM TRACKING ID: 42902501
PROFILE #: OR321468
LINE ITEM: 9b.1
QUANTITY: 1 DT
RECEIVED DATE: 10/07/13

DISPOSAL PROCESS(ES): LANDFILL
FINAL DISPOSAL LOCATION: LANDFILL 13
DISPOSAL DATE: 10/07/13

I certify, on behalf of the above listed treatment facility, that to the best of my knowledge, the above-described waste material was managed in compliance with all applicable laws, regulations, permits and licenses on the date listed above.



CWMNW RECORDS DEPARTMENT

Date: 10/14/13



CHEMICAL WASTE MANAGEMENT OF THE NW

17629 Cedar Springs Lane
Arlington, OR 97812
541 454 2643

PORT OF TACOMA
WAD001882984
3400 TAYLOR WAY
TACOMA WA 98421

CERTIFICATE OF DISPOSAL

Chemical Waste Management of the Northwest, Inc., ORD089452353, has received the following waste material:

GENERATOR:	PORT OF TACOMA
MANIFEST #:	011886786JJK
CWM TRACKING ID:	42902901
PROFILE #:	OR321468
LINE ITEM:	9b.1
QUANTITY:	1 DT
RECEIVED DATE:	10/07/13

DISPOSAL PROCESS(ES):	LANDFILL	
FINAL DISPOSAL LOCATION:	LANDFILL	13
DISPOSAL DATE:	10/07/13	

I certify, on behalf of the above listed treatment facility, that to the best of my knowledge, the above-described waste material was managed in compliance with all applicable laws, regulations, permits and licenses on the date listed above.

Bobbi Jobralin

CWMNW RECORDS DEPARTMENT

Date: 10/14/13



CHEMICAL WASTE MANAGEMENT OF THE NW

17629 Cedar Springs Lane
Arlington, OR 97812
541 454 2643

PORT OF TACOMA
WAD001882984
3400 TAYLOR WAY
TACOMA WA 98421

CERTIFICATE OF DISPOSAL

Chemical Waste Management of the Northwest, Inc., ORD089452353, has received the following waste material:

GENERATOR:	PORT OF TACOMA	
MANIFEST #:	011886788JJK	
CWM TRACKING ID:	42903401	
PROFILE #:	OR321468	
LINE ITEM:	9b.1	
QUANTITY:	1 DT	
RECEIVED DATE:	10/07/13	
DISPOSAL PROCESS(ES):	LANDFILL	
FINAL DISPOSAL LOCATION:	LANDFILL	13
DISPOSAL DATE:	10/07/13	

I certify, on behalf of the above listed treatment facility, that to the best of my knowledge, the above-described waste material was managed in compliance with all applicable laws, regulations, permits and licenses on the date listed above.

Bobbi J. Graham

CWMNW RECORDS DEPARTMENT

Date: 10/14/13



CHEMICAL WASTE MANAGEMENT OF THE NW

17629 Cedar Springs Lane
Arlington, OR 97812
541 454 2643

PORT OF TACOMA
WAD001882984
3400 TAYLOR WAY
TACOMA WA 98421

CERTIFICATE OF DISPOSAL

Chemical Waste Management of the Northwest, Inc., ORD089452353, has received the following waste material:

GENERATOR:	PORT OF TACOMA
MANIFEST #:	011886778JJK
CWM TRACKING ID:	42903501
PROFILE #:	OR321468
LINE ITEM:	9b.1
QUANTITY:	1 DT
RECEIVED DATE:	10/07/13
DISPOSAL PROCESS(ES):	LANDFILL
FINAL DISPOSAL LOCATION:	LANDFILL 13
DISPOSAL DATE:	10/07/13

I certify, on behalf of the above listed treatment facility, that to the best of my knowledge, the above-described waste material was managed in compliance with all applicable laws, regulations, permits and licenses on the date listed above.

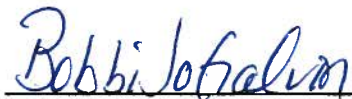

CWMNW RECORDS DEPARTMENT

Date: 10/14/13



CHEMICAL WASTE MANAGEMENT OF THE NW

17629 Cedar Springs Lane
Arlington, OR 97812
541 454 2643

PORT OF TACOMA
WAD001882984
3400 TAYLOR WAY
TACOMA WA 98421

CERTIFICATE OF DISPOSAL

Chemical Waste Management of the Northwest, Inc., ORD089452353, has received the following waste material:

GENERATOR:	PORT OF TACOMA
MANIFEST #:	011886790JJK
CWM TRACKING ID:	42903601
PROFILE #:	OR321468
LINE ITEM:	9b.1
QUANTITY:	1 DT
RECEIVED DATE:	10/07/13
DISPOSAL PROCESS(ES):	LANDFILL
FINAL DISPOSAL LOCATION:	LANDFILL 13
DISPOSAL DATE:	10/07/13

I certify, on behalf of the above listed treatment facility, that to the best of my knowledge, the above-described waste material was managed in compliance with all applicable laws, regulations, permits and licenses on the date listed above.

Bobbi J. Fialon

CWMNW RECORDS DEPARTMENT

Date: 10/14/13



CHEMICAL WASTE MANAGEMENT OF THE NW

17629 Cedar Springs Lane
Arlington, OR 97812
541 454 2643

PORT OF TACOMA
WAD001882984
3400 TAYLOR WAY
TACOMA WA 98421

CERTIFICATE OF DISPOSAL

Chemical Waste Management of the Northwest, Inc., ORD089452353, has received the following waste material:

GENERATOR:	PORT OF TACOMA
MANIFEST #:	011886782JJK
CWM TRACKING ID:	42903901
PROFILE #:	OR321468
LINE ITEM:	9b.1
QUANTITY:	1 DT
RECEIVED DATE:	10/07/13
DISPOSAL PROCESS(ES):	LANDFILL
FINAL DISPOSAL LOCATION:	LANDFILL 13
DISPOSAL DATE:	10/07/13

I certify, on behalf of the above listed treatment facility, that to the best of my knowledge, the above-described waste material was managed in compliance with all applicable laws, regulations, permits and licenses on the date listed above.



CWMNW RECORDS DEPARTMENT

Date: 10/14/13



CHEMICAL WASTE MANAGEMENT OF THE NW

17629 Cedar Springs Lane
Arlington, OR 97812
541 454 2643

PORT OF TACOMA
WAD001882984
3400 TAYLOR WAY
TACOMA WA 98421

CERTIFICATE OF DISPOSAL

Chemical Waste Management of the Northwest, Inc., ORD089452353, has received the following waste material:

GENERATOR:	PORT OF TACOMA
MANIFEST #:	011886789JJK
CWM TRACKING ID:	42904101
PROFILE #:	OR321468
LINE ITEM:	9b.1
QUANTITY:	1 DT
RECEIVED DATE:	10/07/13
DISPOSAL PROCESS(ES):	LANDFILL
FINAL DISPOSAL LOCATION:	LANDFILL 13
DISPOSAL DATE:	10/07/13

I certify, on behalf of the above listed treatment facility, that to the best of my knowledge, the above-described waste material was managed in compliance with all applicable laws, regulations, permits and licenses on the date listed above.

Robbi Johalvin

CWMNW RECORDS DEPARTMENT

Date: 10/14/13



CHEMICAL WASTE MANAGEMENT OF THE NW

17629 Cedar Springs Lane
Arlington, OR 97812
541 454 2643

PORT OF TACOMA
WAD001882984
3400 TAYLOR WAY
TACOMA WA 98421

CERTIFICATE OF DISPOSAL

Chemical Waste Management of the Northwest, Inc., ORD089452353, has received the following waste material:

GENERATOR:	PORT OF TACOMA
MANIFEST #:	011886784JJK
CWM TRACKING ID:	42904201
PROFILE #:	OR321468
LINE ITEM:	9b.1
QUANTITY:	1 DT
RECEIVED DATE:	10/07/13
DISPOSAL PROCESS(ES):	LANDFILL
FINAL DISPOSAL LOCATION:	LANDFILL 13
DISPOSAL DATE:	10/07/13

I certify, on behalf of the above listed treatment facility, that to the best of my knowledge, the above-described waste material was managed in compliance with all applicable laws, regulations, permits and licenses on the date listed above.

Robbi Jo Galvin

CWMNW RECORDS DEPARTMENT

Date: 10/14/13



CHEMICAL WASTE MANAGEMENT OF THE NW

17629 Cedar Springs Lane
Arlington, OR 97812
541 454 2643

PORT OF TACOMA
WAD001882984
3400 TAYLOR WAY
TACOMA WA 98421

CERTIFICATE OF DISPOSAL

Chemical Waste Management of the Northwest, Inc., ORD089452353, has received the following waste material:

GENERATOR:	PORT OF TACOMA
MANIFEST #:	011886777JJK
CWM TRACKING ID:	42904401
PROFILE #:	OR321468
LINE ITEM:	9b.1
QUANTITY:	1 DT
RECEIVED DATE:	10/07/13
DISPOSAL PROCESS(ES):	LANDFILL
FINAL DISPOSAL LOCATION:	LANDFILL 13
DISPOSAL DATE:	10/07/13

I certify, on behalf of the above listed treatment facility, that to the best of my knowledge, the above-described waste material was managed in compliance with all applicable laws, regulations, permits and licenses on the date listed above.



CWMNW RECORDS DEPARTMENT

Date: 10/14/13



CHEMICAL WASTE MANAGEMENT OF THE NW

17629 Cedar Springs Lane
Arlington, OR 97812
541 454 2643

PORT OF TACOMA
WAD001882984
3400 TAYLOR WAY
TACOMA WA 98421

CERTIFICATE OF DISPOSAL

Chemical Waste Management of the Northwest, Inc., ORD089452353, has received the following waste material:

GENERATOR:	PORT OF TACOMA
MANIFEST #:	011886776JJK
CWM TRACKING ID:	42904601
PROFILE #:	OR321468
LINE ITEM:	9b.1
QUANTITY:	1 DT
RECEIVED DATE:	10/07/13
DISPOSAL PROCESS(ES):	LANDFILL
FINAL DISPOSAL LOCATION:	LANDFILL 13
DISPOSAL DATE:	10/07/13

I certify, on behalf of the above listed treatment facility, that to the best of my knowledge, the above-described waste material was managed in compliance with all applicable laws, regulations, permits and licenses on the date listed above.

Bobbi J. Graham

CWMNW RECORDS DEPARTMENT

Date: 10/14/13





CHEMICAL WASTE MANAGEMENT OF THE NW

17629 Cedar Springs Lane
Arlington, OR 97812
541 454 2643

PORT OF TACOMA
WAD001882984
3400 TAYLOR WAY
TACOMA WA 98421

CERTIFICATE OF DISPOSAL

Chemical Waste Management of the Northwest, Inc., ORD089452353, has received the following waste material:

GENERATOR:	PORT OF TACOMA
MANIFEST #:	011886783JJK
CWM TRACKING ID:	42904701
PROFILE #:	OR321468
LINE ITEM:	9b.1
QUANTITY:	1 DT
RECEIVED DATE:	10/07/13
DISPOSAL PROCESS(ES):	LANDFILL
FINAL DISPOSAL LOCATION:	LANDFILL 13
DISPOSAL DATE:	10/07/13

I certify, on behalf of the above listed treatment facility, that to the best of my knowledge, the above-described waste material was managed in compliance with all applicable laws, regulations, permits and licenses on the date listed above.

Bibbi Jo Galvin

CWMNW RECORDS DEPARTMENT

Date: 10/14/13



CHEMICAL WASTE MANAGEMENT OF THE NW

17629 Cedar Springs Lane
Arlington, OR 97812
541 454 2643

PORT OF TACOMA
WAD001882984
3400 TAYLOR WAY
TACOMA WA 98421

CERTIFICATE OF DISPOSAL

Chemical Waste Management of the Northwest, Inc., ORD089452353, has received the following waste material:

GENERATOR:	PORT OF TACOMA
MANIFEST #:	011886793JJK
CWM TRACKING ID:	42905501
PROFILE #:	OR321468
LINE ITEM:	9b.1
QUANTITY:	1 DT
RECEIVED DATE:	10/08/13
DISPOSAL PROCESS(ES):	LANDFILL
FINAL DISPOSAL LOCATION:	LANDFILL 14
DISPOSAL DATE:	10/08/13

I certify, on behalf of the above listed treatment facility, that to the best of my knowledge, the above-described waste material was managed in compliance with all applicable laws, regulations, permits and licenses on the date listed above.

Bobbi Jo Balvin

CWMNW RECORDS DEPARTMENT

Date: 10/14/13



CHEMICAL WASTE MANAGEMENT OF THE NW

17629 Cedar Springs Lane
Arlington, OR 97812
541 454 2643

PORT OF TACOMA
WAD001882984
3400 TAYLOR WAY
TACOMA WA 98421

CERTIFICATE OF DISPOSAL

Chemical Waste Management of the Northwest, Inc., ORD089452353, has received the following waste material:

GENERATOR:	PORT OF TACOMA
MANIFEST #:	011886729JJK
CWM TRACKING ID:	42906801
PROFILE #:	OR321468
LINE ITEM:	9b.1
QUANTITY:	1 DT
RECEIVED DATE:	10/08/13
DISPOSAL PROCESS(ES):	LANDFILL
FINAL DISPOSAL LOCATION:	LANDFILL 13
DISPOSAL DATE:	10/08/13

I certify, on behalf of the above listed treatment facility, that to the best of my knowledge, the above-described waste material was managed in compliance with all applicable laws, regulations, permits and licenses on the date listed above.

Bobbi J. Galvin

CWMNW RECORDS DEPARTMENT

Date: 10/14/13



CHEMICAL WASTE MANAGEMENT OF THE NW

17629 Cedar Springs Lane
Arlington, OR 97812
541 454 2643

PORT OF TACOMA
WAD001882984
3400 TAYLOR WAY
TACOMA WA 98421

CERTIFICATE OF DISPOSAL

Chemical Waste Management of the Northwest, Inc., ORD089452353, has received the following waste material:

GENERATOR:	PORT OF TACOMA
MANIFEST #:	011886730JJK
CWM TRACKING ID:	42906901
PROFILE #:	OR321468
LINE ITEM:	9b.1
QUANTITY:	1 DT
RECEIVED DATE:	10/08/13
DISPOSAL PROCESS(ES):	LANDFILL
FINAL DISPOSAL LOCATION:	LANDFILL 13
DISPOSAL DATE:	10/08/13

I certify, on behalf of the above listed treatment facility, that to the best of my knowledge, the above-described waste material was managed in compliance with all applicable laws, regulations, permits and licenses on the date listed above.

Bobbi Galvin

CWMNW RECORDS DEPARTMENT

Date: 10/14/13



CHEMICAL WASTE MANAGEMENT OF THE NW

17629 Cedar Springs Lane
Arlington, OR 97812
541 454 2643

PORT OF TACOMA
WAD001882984
3400 TAYLOR WAY
TACOMA WA 98421

CERTIFICATE OF DISPOSAL

Chemical Waste Management of the Northwest, Inc., ORD089452353, has received the following waste material:

GENERATOR:	PORT OF TACOMA
MANIFEST #:	011886728JJK
CWM TRACKING ID:	42907001
PROFILE #:	OR321468
LINE ITEM:	9b.1
QUANTITY:	1 DT
RECEIVED DATE:	10/08/13
DISPOSAL PROCESS(ES):	LANDFILL
FINAL DISPOSAL LOCATION:	LANDFILL 13
DISPOSAL DATE:	10/08/13

I certify, on behalf of the above listed treatment facility, that to the best of my knowledge, the above-described waste material was managed in compliance with all applicable laws, regulations, permits and licenses on the date listed above.

Bobbi Johnson

CWMNW RECORDS DEPARTMENT

Date: 10/14/13



CHEMICAL WASTE MANAGEMENT OF THE NW

17629 Cedar Springs Lane
Arlington, OR 97812
541 454 2643

PORT OF TACOMA
WAD001882984
3400 TAYLOR WAY
TACOMA WA 98421

CERTIFICATE OF DISPOSAL

Chemical Waste Management of the Northwest, Inc., ORD089452353, has received the following waste material:

GENERATOR:	PORT OF TACOMA
MANIFEST #:	011886726JJK
CWM TRACKING ID:	42907201
PROFILE #:	OR321468
LINE ITEM:	9b.1
QUANTITY:	1 DT
RECEIVED DATE:	10/08/13
DISPOSAL PROCESS(ES):	LANDFILL
FINAL DISPOSAL LOCATION:	LANDFILL 13
DISPOSAL DATE:	10/08/13

I certify, on behalf of the above listed treatment facility, that to the best of my knowledge, the above-described waste material was managed in compliance with all applicable laws, regulations, permits and licenses on the date listed above.

Bobbi Jo Aralin

CWMNW RECORDS DEPARTMENT

Date: 10/14/13



CHEMICAL WASTE MANAGEMENT OF THE NW
17629 Cedar Springs Lane
Arlington, OR 97812
541 454 2643

PORT OF TACOMA
WAD001882984
3400 TAYLOR WAY
TACOMA WA 98421

CERTIFICATE OF DISPOSAL

Chemical Waste Management of the Northwest, Inc., ORD089452353, has received the following waste material:

GENERATOR:	PORT OF TACOMA
MANIFEST #:	011886732JJK
CWM TRACKING ID:	42907301
PROFILE #:	OR321468
LINE ITEM:	9b.1
QUANTITY:	1 DT
RECEIVED DATE:	10/08/13
DISPOSAL PROCESS(ES):	LANDFILL
FINAL DISPOSAL LOCATION:	LANDFILL 13
DISPOSAL DATE:	10/08/13

I certify, on behalf of the above listed treatment facility, that to the best of my knowledge, the above-described waste material was managed in compliance with all applicable laws, regulations, permits and licenses on the date listed above.

Bobbi Jo Galvin

CWMNW RECORDS DEPARTMENT
Date: 10/14/13



CHEMICAL WASTE MANAGEMENT OF THE NW

17629 Cedar Springs Lane
Arlington, OR 97812
541 454 2643

PORT OF TACOMA
WAD001882984
3400 TAYLOR WAY
TACOMA WA 98421

CERTIFICATE OF DISPOSAL

Chemical Waste Management of the Northwest, Inc., ORD089452353, has received the following waste material:

GENERATOR:	PORT OF TACOMA
MANIFEST #:	011886733JJK
CWM TRACKING ID:	42907601
PROFILE #:	OR321468
LINE ITEM:	9b.1
QUANTITY:	1 DT
RECEIVED DATE:	10/08/13
DISPOSAL PROCESS(ES):	LANDFILL
FINAL DISPOSAL LOCATION:	LANDFILL 14
DISPOSAL DATE:	10/08/13

I certify, on behalf of the above listed treatment facility, that to the best of my knowledge, the above-described waste material was managed in compliance with all applicable laws, regulations, permits and licenses on the date listed above.

Bobbin Galvin

CWMNW RECORDS DEPARTMENT

Date: 10/14/13



CHEMICAL WASTE MANAGEMENT OF THE NW

17629 Cedar Springs Lane
Arlington, OR 97812
541 454 2643

PORT OF TACOMA
WAD001882984
3400 TAYLOR WAY
TACOMA WA 98421

CERTIFICATE OF DISPOSAL

Chemical Waste Management of the Northwest, Inc., ORD089452353, has received the following waste material:

GENERATOR:	PORT OF TACOMA
MANIFEST #:	011886734JJK
CWM TRACKING ID:	42907701
PROFILE #:	OR321468
LINE ITEM:	9b.1
QUANTITY:	1 DT
RECEIVED DATE:	10/08/13
DISPOSAL PROCESS(ES):	LANDFILL
FINAL DISPOSAL LOCATION:	LANDFILL 14
DISPOSAL DATE:	10/08/13

I certify, on behalf of the above listed treatment facility, that to the best of my knowledge, the above-described waste material was managed in compliance with all applicable laws, regulations, permits and licenses on the date listed above.

Bobbi Jo Balvin

CWMNW RECORDS DEPARTMENT

Date: 10/14/13



CHEMICAL WASTE MANAGEMENT OF THE NW

17629 Cedar Springs Lane
Arlington, OR 97812
541 454 2643

PORT OF TACOMA
WAD001882984
3400 TAYLOR WAY
TACOMA WA 98421

CERTIFICATE OF DISPOSAL

Chemical Waste Management of the Northwest, Inc., ORD089452353, has received the following waste material:

GENERATOR:	PORT OF TACOMA
MANIFEST #:	011886738JJK
CWM TRACKING ID:	42907801
PROFILE #:	OR321468
LINE ITEM:	9b.1
QUANTITY:	1 DT
RECEIVED DATE:	10/08/13
DISPOSAL PROCESS(ES):	LANDFILL
FINAL DISPOSAL LOCATION:	LANDFILL 14
DISPOSAL DATE:	10/09/13

I certify, on behalf of the above listed treatment facility, that to the best of my knowledge, the above-described waste material was managed in compliance with all applicable laws, regulations, permits and licenses on the date listed above.

Bobbi Jo Galvin

CWMNW RECORDS DEPARTMENT

Date: 10/14/13



CHEMICAL WASTE MANAGEMENT OF THE NW

17629 Cedar Springs Lane
Arlington, OR 97812
541 454 2643

PORT OF TACOMA
WAD001882984
3400 TAYLOR WAY
TACOMA WA 98421

CERTIFICATE OF DISPOSAL

Chemical Waste Management of the Northwest, Inc., ORD089452353, has received the following waste material:

GENERATOR:	PORT OF TACOMA
MANIFEST #:	011886736JJK
CWM TRACKING ID:	42907901
PROFILE #:	OR321468
LINE ITEM:	9b.1
QUANTITY:	1 DT
RECEIVED DATE:	10/08/13
DISPOSAL PROCESS(ES):	LANDFILL
FINAL DISPOSAL LOCATION:	LANDFILL 14
DISPOSAL DATE:	10/08/13

I certify, on behalf of the above listed treatment facility, that to the best of my knowledge, the above-described waste material was managed in compliance with all applicable laws, regulations, permits and licenses on the date listed above.

Bobbi Jo Galvin

CWMNW RECORDS DEPARTMENT

Date: 10/14/13



CHEMICAL WASTE MANAGEMENT OF THE NW

17629 Cedar Springs Lane
Arlington, OR 97812
541 454 2643

PORT OF TACOMA
WAD001882984
3400 TAYLOR WAY
TACOMA WA 98421

CERTIFICATE OF DISPOSAL

Chemical Waste Management of the Northwest, Inc., ORD089452353, has received the following waste material:

GENERATOR:	PORT OF TACOMA
MANIFEST #:	011886739JJK
CWM TRACKING ID:	42908001
PROFILE #:	OR321468
LINE ITEM:	9b.1
QUANTITY:	1 DT
RECEIVED DATE:	10/08/13
DISPOSAL PROCESS(ES):	LANDFILL
FINAL DISPOSAL LOCATION:	LANDFILL 14
DISPOSAL DATE:	10/03/13

I certify, on behalf of the above listed treatment facility, that to the best of my knowledge, the above-described waste material was managed in compliance with all applicable laws, regulations, permits and licenses on the date listed above.

Bobbi Jo Galvin

CWMNW RECORDS DEPARTMENT

Date: 10/14/13



CHEMICAL WASTE MANAGEMENT OF THE NW

17629 Cedar Springs Lane
Arlington, OR 97812
541 454 2643

PORT OF TACOMA
WAD001882984
3400 TAYLOR WAY
TACOMA WA 98421

CERTIFICATE OF DISPOSAL

Chemical Waste Management of the Northwest, Inc., ORD089452353, has received the following waste material:

GENERATOR:	PORT OF TACOMA
MANIFEST #:	011886735JJK
CWM TRACKING ID:	42908201
PROFILE #:	OR321468
LINE ITEM:	9b.1
QUANTITY:	1 DT
RECEIVED DATE:	10/08/13
DISPOSAL PROCESS(ES):	LANDFILL
FINAL DISPOSAL LOCATION:	LANDFILL 13
DISPOSAL DATE:	10/08/13

I certify, on behalf of the above listed treatment facility, that to the best of my knowledge, the above-described waste material was managed in compliance with all applicable laws, regulations, permits and licenses on the date listed above.

Robbi Jo Galun

CWMNW RECORDS DEPARTMENT

Date: 10/14/13



CHEMICAL WASTE MANAGEMENT OF THE NW

17629 Cedar Springs Lane
Arlington, OR 97812
541 454 2643

PORT OF TACOMA
WAD001882984
3400 TAYLOR WAY
TACOMA WA 98421

CERTIFICATE OF DISPOSAL

Chemical Waste Management of the Northwest, Inc., ORD089452353, has received the following waste material:

GENERATOR:	PORT OF TACOMA
MANIFEST #:	011886727JJK
CWM TRACKING ID:	42908301
PROFILE #:	OR321468
LINE ITEM:	9b.1
QUANTITY:	1 DT
RECEIVED DATE:	10/08/13
DISPOSAL PROCESS(ES):	LANDFILL
FINAL DISPOSAL LOCATION:	LANDFILL 13
DISPOSAL DATE:	10/08/13

I certify, on behalf of the above listed treatment facility, that to the best of my knowledge, the above-described waste material was managed in compliance with all applicable laws, regulations, permits and licenses on the date listed above.

Bobbi Johnson

CWMNW RECORDS DEPARTMENT

Date: 10/14/13



CHEMICAL WASTE MANAGEMENT OF THE NW

17629 Cedar Springs Lane
Arlington, OR 97812
541 454 2643

PORT OF TACOMA
WAD001882984
3400 TAYLOR WAY
TACOMA WA 98421

CERTIFICATE OF DISPOSAL

Chemical Waste Management of the Northwest, Inc., ORD089452353, has received the following waste material:

GENERATOR:	PORT OF TACOMA
MANIFEST #:	011886731JJK
CWM TRACKING ID:	42908401
PROFILE #:	OR321468
LINE ITEM:	9b.1
QUANTITY:	1 DT
RECEIVED DATE:	10/08/13
DISPOSAL PROCESS(ES):	LANDFILL
FINAL DISPOSAL LOCATION:	LANDFILL 13
DISPOSAL DATE:	10/08/13

I certify, on behalf of the above listed treatment facility, that to the best of my knowledge, the above-described waste material was managed in compliance with all applicable laws, regulations, permits and licenses on the date listed above.

Bobbi J. Galun

CWMNW RECORDS DEPARTMENT

Date: 10/14/13



CHEMICAL WASTE MANAGEMENT OF THE NW

17629 Cedar Springs Lane
Arlington, OR 97812
541 454 2643

PORT OF TACOMA
WAD001882984
3400 TAYLOR WAY
TACOMA WA 98421

CERTIFICATE OF DISPOSAL

Chemical Waste Management of the Northwest, Inc., ORD089452353, has received the following waste material:

GENERATOR:	PORT OF TACOMA
MANIFEST #:	011886737JJK
CWM TRACKING ID:	42908701
PROFILE #:	OR321468
LINE ITEM:	9b.1
QUANTITY:	1 DT
RECEIVED DATE:	10/08/13
DISPOSAL PROCESS(ES):	LANDFILL
FINAL DISPOSAL LOCATION:	LANDFILL 13
DISPOSAL DATE:	10/08/13

I certify, on behalf of the above listed treatment facility, that to the best of my knowledge, the above-described waste material was managed in compliance with all applicable laws, regulations, permits and licenses on the date listed above.



CWMNW RECORDS DEPARTMENT

Date: 10/14/13



CHEMICAL WASTE MANAGEMENT OF THE NW

17629 Cedar Springs Lane
Arlington, OR 97812
541 454 2643

PORT OF TACOMA
WAD001882984
3400 TAYLOR WAY
TACOMA WA 98421

CERTIFICATE OF DISPOSAL

Chemical Waste Management of the Northwest, Inc., ORD089452353, has received the following waste material:

GENERATOR:	PORT OF TACOMA
MANIFEST #:	011886740JJK
CWM TRACKING ID:	42909201
PROFILE #:	OR 21468
LINE ITEM:	9b.1
QUANTITY:	1 DT
RECEIVED DATE:	10/08/13
DISPOSAL PROCESS(ES):	LANDFILL
FINAL DISPOSAL LOCATION:	LANDFILL 13
DISPOSAL DATE:	10/08/13

I certify, on behalf of the above listed treatment facility, that to the best of my knowledge, the above-described waste material was managed in compliance with all applicable laws, regulations, permits and licenses on the date listed above.

Robbi Jo Galvin

CWMNW RECORDS DEPARTMENT

Date: 10/14/13



CHEMICAL WASTE MANAGEMENT OF THE NW

17629 Cedar Springs Lane
Arlington, OR 97812
541 454 2643

PORT OF TACOMA
WAD001882984
3400 TAYLOR WAY
TACOMA WA 98421

CERTIFICATE OF DISPOSAL

Chemical Waste Management of the Northwest, Inc., ORD089452353, has received the following waste material:

GENERATOR:	PORT OF TACOMA
MANIFEST #:	011886741JJK
CWM TRACKING ID:	42909301
PROFILE #:	OR321468
LINE ITEM:	9b.1
QUANTITY:	1 DT
RECEIVED DATE:	10/08/13
DISPOSAL PROCESS(ES):	LANDFILL
FINAL DISPOSAL LOCATION:	LANDFILL 13
DISPOSAL DATE:	10/08/13

I certify, on behalf of the above listed treatment facility, that to the best of my knowledge, the above-described waste material was managed in compliance with all applicable laws, regulations, permits and licenses on the date listed above.

Bobbi Jo Galvin

CWMNW RECORDS DEPARTMENT

Date: 10/14/13



CHEMICAL WASTE MANAGEMENT OF THE NW

17629 Cedar Springs Lane
Arlington, OR 97812
541 454 2643

PORT OF TACOMA
WAD001882984
3400 TAYLOR WAY
TACOMA WA 98421

CERTIFICATE OF DISPOSAL

Chemical Waste Management of the Northwest, Inc., ORD089452353, has received the following waste material:

GENERATOR:	PORT OF TACOMA
MANIFEST #:	011886742JJK
CWM TRACKING ID:	42909401
PROFILE #:	OR21468
LINE ITEM:	9b.1
QUANTITY:	1 DT
RECEIVED DATE:	10/08/13
DISPOSAL PROCESS(ES):	LANDFILL
FINAL DISPOSAL LOCATION:	LANDFILL 13
DISPOSAL DATE:	10/08/13

I certify, on behalf of the above listed treatment facility, that to the best of my knowledge, the above-described waste material was managed in compliance with all applicable laws, regulations, permits and licenses on the date listed above.

Bobbi Jofalvin

CWMNW RECORDS DEPARTMENT

Date: 10/14/13



CHEMICAL WASTE MANAGEMENT OF THE NW

17629 Cedar Springs Lane
Arlington, OR 97812
541 454 2643

PORT OF TACOMA
WAD001882984
3400 TAYLOR WAY
TACOMA WA 98421

CERTIFICATE OF DISPOSAL

Chemical Waste Management of the Northwest, Inc., ORD089452353, has received the following waste material:

GENERATOR: PORT OF TACOMA
MANIFEST #: 011886744JJK
CWM TRACKING ID: 42909501
PROFILE #: OR321468
LINE ITEM: 9b.1
QUANTITY: 1 DT
RECEIVED DATE: 10/08/13

DISPOSAL PROCESS(ES): LANDFILL
FINAL DISPOSAL LOCATION: LANDFILL 13
DISPOSAL DATE: 10/08/13

I certify, on behalf of the above listed treatment facility, that to the best of my knowledge, the above-described waste material was managed in compliance with all applicable laws, regulations, permits and licenses on the date listed above.

Robbi Jo Galvin

CWMNW RECORDS DEPARTMENT

Date: 10/14/13



CHEMICAL WASTE MANAGEMENT OF THE NW

17629 Cedar Springs Lane
Arlington, OR 97812
541 454 2643

PORT OF TACOMA
WAD001882984
3400 TAYLOR WAY
TACOMA WA 98421

CERTIFICATE OF DISPOSAL

Chemical Waste Management of the Northwest, Inc., ORD089452353, has received the following waste material:

GENERATOR:	PORT OF TACOMA
MANIFEST #:	011886743JJK
CWM TRACKING ID:	42909601
PROFILE #:	OR321468
LINE ITEM:	9b.1
QUANTITY:	1 DT
RECEIVED DATE:	10/08/13
DISPOSAL PROCESS(ES):	LANDFILL
FINAL DISPOSAL LOCATION:	LANDFILL 13
DISPOSAL DATE:	10/08/13

I certify, on behalf of the above listed treatment facility, that to the best of my knowledge, the above-described waste material was managed in compliance with all applicable laws, regulations, permits and licenses on the date listed above.

Robbie Galvin

CWMNW RECORDS DEPARTMENT
Date: 10/14/13



CHEMICAL WASTE MANAGEMENT OF THE NW

17629 Cedar Springs Lane
Arlington, OR 97812
541 454 2643

PORT OF TACOMA
WAD001882984
3400 TAYLOR WAY
TACOMA WA 98421

CERTIFICATE OF DISPOSAL

Chemical Waste Management of the Northwest, Inc., ORD089452353, has received the following waste material:

GENERATOR:	PORT OF TACOMA
MANIFEST #:	011886754JJK
CWM TRACKING ID:	42913701
PROFILE #:	OR321468
LINE ITEM:	9b.1
QUANTITY:	1 DT
RECEIVED DATE:	10/09/13
DISPOSAL PROCESS(ES):	LANDFILL
FINAL DISPOSAL LOCATION:	LANDFILL 13
DISPOSAL DATE:	10/09/13

I certify, on behalf of the above listed treatment facility, that to the best of my knowledge, the above-described waste material was managed in compliance with all applicable laws, regulations, permits and licenses on the date listed above.



CWMNW RECORDS DEPARTMENT

Date: 10/15/13



CHEMICAL WASTE MANAGEMENT OF THE NW

17629 Cedar Springs Lane
Arlington, OR 97812
541 454 2643

PORT OF TACOMA
WAD001882984
3400 TAYLOR WAY
TACOMA WA 98421

CERTIFICATE OF DISPOSAL

Chemical Waste Management of the Northwest, Inc., ORD089452353, has received the following waste material:

GENERATOR:	PORT OF TACOMA
MANIFEST #:	011886753JJK
CWM TRACKING ID:	42914001
PROFILE #:	OR321468
LINE ITEM:	9b.1
QUANTITY:	1 DT
RECEIVED DATE:	10/09/13
DISPOSAL PROCESS(ES):	LANDFILL
FINAL DISPOSAL LOCATION:	LANDFILL 13
DISPOSAL DATE:	10/09/13

I certify, on behalf of the above listed treatment facility, that to the best of my knowledge, the above-described waste material was managed in compliance with all applicable laws, regulations, permits and licenses on the date listed above.

CWMNW RECORDS DEPARTMENT

Date: 10/15/13



CHEMICAL WASTE MANAGEMENT OF THE NW

17629 Cedar Springs Lane
Arlington, OR 97812
541 454 2643

PORT OF TACOMA
WAD001882984
3400 TAYLOR WAY
TACOMA WA 98421

CERTIFICATE OF DISPOSAL

Chemical Waste Management of the Northwest, Inc., ORD089452353, has received the following waste material:

GENERATOR:	PORT OF TACOMA
MANIFEST #:	011886750JJK
CWM TRACKING ID:	42914101
PROFILE #:	OR321468
LINE ITEM:	9b.1
QUANTITY:	1 DT
RECEIVED DATE:	10/09/13
DISPOSAL PROCESS(ES):	LANDFILL
FINAL DISPOSAL LOCATION:	LANDFILL 13
DISPOSAL DATE:	10/09/13

I certify, on behalf of the above listed treatment facility, that to the best of my knowledge, the above-described waste material was managed in compliance with all applicable laws, regulations, permits and licenses on the date listed above.

Bobbito Galvin

CWMNW RECORDS DEPARTMENT

Date: 10/15/13



CHEMICAL WASTE MANAGEMENT OF THE NW

17629 Cedar Springs Lane
Arlington, OR 97812
541 454 2643

PORT OF TACOMA
WAD001882984
3400 TAYLOR WAY
TACOMA WA 98421

CERTIFICATE OF DISPOSAL

Chemical Waste Management of the Northwest, Inc., ORD089452353, has received the following waste material:

GENERATOR:	PORT OF TACOMA
MANIFEST #:	011886746JJK
CWM TRACKING ID:	42914201
PROFILE #:	OR321468
LINE ITEM:	9b.1
QUANTITY:	1 DT
RECEIVED DATE:	10/09/13
DISPOSAL PROCESS(ES):	LANDFILL
FINAL DISPOSAL LOCATION:	LANDFILL 13
DISPOSAL DATE:	10/09/13

I certify, on behalf of the above listed treatment facility, that to the best of my knowledge, the above-described waste material was managed in compliance with all applicable laws, regulations, permits and licenses on the date listed above.

Bobbi Sohalun

CWMNW RECORDS DEPARTMENT

Date: 10/15/13



CHEMICAL WASTE MANAGEMENT OF THE NW

17629 Cedar Springs Lane
Arlington, OR 97812
541 454 2643

PORT OF TACOMA
WAD001882984
3400 TAYLOR WAY
TACOMA WA 98421

CERTIFICATE OF DISPOSAL

Chemical Waste Management of the Northwest, Inc., ORD089452353, has received the following waste material:

GENERATOR:	PORT OF TACOMA
MANIFEST #:	011886752JJK
CWM TRACKING ID:	42914401
PROFILE #:	OR321468
LINE ITEM:	9b.1
QUANTITY:	1 DT
RECEIVED DATE:	10/09/13
DISPOSAL PROCESS(ES):	LANDFILL
FINAL DISPOSAL LOCATION:	LANDFILL 13
DISPOSAL DATE:	10/09/13

I certify, on behalf of the above listed treatment facility, that to the best of my knowledge, the above-described waste material was managed in compliance with all applicable laws, regulations, permits and licenses on the date listed above.



CWMNW RECORDS DEPARTMENT

Date: 10/15/13



CHEMICAL WASTE MANAGEMENT OF THE NW

17629 Cedar Springs Lane
Arlington, OR 97812
541 454 2643

PORT OF TACOMA
WAD001882984
3400 TAYLOR WAY
TACOMA WA 98421

CERTIFICATE OF DISPOSAL

Chemical Waste Management of the Northwest, Inc., ORD089452353, has received the following waste material:

GENERATOR:	PORT OF TACOMA
MANIFEST #:	011886756JJK
CWM TRACKING ID:	42914501
PROFILE #:	OR321468
LINE ITEM:	9b.1
QUANTITY:	1 DT
RECEIVED DATE:	10/09/13
DISPOSAL PROCESS(ES):	LANDFILL
FINAL DISPOSAL LOCATION:	LANDFILL 13
DISPOSAL DATE:	10/09/13

I certify, on behalf of the above listed treatment facility, that to the best of my knowledge, the above-described waste material was managed in compliance with all applicable laws, regulations, permits and licenses on the date listed above.

CWMNW RECORDS DEPARTMENT

Date: 10/15/13



CHEMICAL WASTE MANAGEMENT OF THE NW

17629 Cedar Springs Lane
Arlington, OR 97812
541 454 2643

PORT OF TACOMA
WAD001882984
3400 TAYLOR WAY
TACOMA WA 98421

CERTIFICATE OF DISPOSAL

Chemical Waste Management of the Northwest, Inc., ORD089452353, has received the following waste material:

GENERATOR:	PORT OF TACOMA
MANIFEST #:	011886745JJK
CWM TRACKING ID:	42914801
PROFILE #:	OR321468
LINE ITEM:	9b.1
QUANTITY:	1 DT
RECEIVED DATE:	10/09/13
DISPOSAL PROCESS(ES):	LANDFILL
FINAL DISPOSAL LOCATION:	LANDFILL 13
DISPOSAL DATE:	10/09/13

I certify, on behalf of the above listed treatment facility, that to the best of my knowledge, the above-described waste material was managed in compliance with all applicable laws, regulations, permits and licenses on the date listed above.

Bobbi J. Galvin

CWMNW RECORDS DEPARTMENT

Date: 10/15/13



CHEMICAL WASTE MANAGEMENT OF THE NW

17629 Cedar Springs Lane
Arlington, OR 97812
541 454 2643

PORT OF TACOMA
WAD001882984
3400 TAYLOR WAY
TACOMA WA 98421

CERTIFICATE OF DISPOSAL

Chemical Waste Management of the Northwest, Inc., ORD089452353, has received the following waste material:

GENERATOR:	PORT OF TACOMA
MANIFEST #:	011886761JJK
CWM TRACKING ID:	42915301
PROFILE #:	OR321468
LINE ITEM:	9b.1
QUANTITY:	1 DT
RECEIVED DATE:	10/09/13
DISPOSAL PROCESS(ES):	LANDFILL
FINAL DISPOSAL LOCATION:	LANDFILL 13
DISPOSAL DATE:	10/09/13

I certify, on behalf of the above listed treatment facility, that to the best of my knowledge, the above-described waste material was managed in compliance with all applicable laws, regulations, permits and licenses on the date listed above.



CWMNW RECORDS DEPARTMENT

Date: 10/15/13



CHEMICAL WASTE MANAGEMENT OF THE NW

17629 Cedar Springs Lane
Arlington, OR 97812
541 454 2643

PORT OF TACOMA
WAD001882984
3400 TAYLOR WAY
TACOMA WA 98421

CERTIFICATE OF DISPOSAL

Chemical Waste Management of the Northwest, Inc., ORD089452353, has received the following waste material:

GENERATOR:	PORT OF TACOMA
MANIFEST #:	011886759JJK
CWM TRACKING ID:	42915401
PROFILE #:	OR321468
LINE ITEM:	9b.1
QUANTITY:	1 DT
RECEIVED DATE:	10/09/13
DISPOSAL PROCESS(ES):	LANDFILL
FINAL DISPOSAL LOCATION:	LANDFILL 13
DISPOSAL DATE:	10/09/13

I certify, on behalf of the above listed treatment facility, that to the best of my knowledge, the above-described waste material was managed in compliance with all applicable laws, regulations, permits and licenses on the date listed above.

CWMNW RECORDS DEPARTMENT

Date: 10/15/13



CHEMICAL WASTE MANAGEMENT OF THE NW

17629 Cedar Springs Lane
Arlington, OR 97812
541 454 2643

PORT OF TACOMA
WAD001882984
3400 TAYLOR WAY
TACOMA WA 98421

CERTIFICATE OF DISPOSAL

Chemical Waste Management of the Northwest, Inc., ORD089452353, has received the following waste material:

GENERATOR:	PORT OF TACOMA
MANIFEST #:	011886758JJK
CWM TRACKING ID:	42916201
PROFILE #:	OR321468
LINE ITEM:	9b.1
QUANTITY:	1 DT
RECEIVED DATE:	10/09/13
DISPOSAL PROCESS(ES):	LANDFILL
FINAL DISPOSAL LOCATION:	LANDFILL 13
DISPOSAL DATE:	10/09/13

I certify, on behalf of the above listed treatment facility, that to the best of my knowledge, the above-described waste material was managed in compliance with all applicable laws, regulations, permits and licenses on the date listed above.



CWMNW RECORDS DEPARTMENT

Date: 10/15/13



CHEMICAL WASTE MANAGEMENT OF THE NW

17629 Cedar Springs Lane
Arlington, OR 97812
541 454 2643

PORT OF TACOMA
WAD001882984
3400 TAYLOR WAY
TACOMA WA 98421

CERTIFICATE OF DISPOSAL

Chemical Waste Management of the Northwest, Inc., ORD089452353, has received the following waste material:

GENERATOR:	PORT OF TACOMA
MANIFEST #:	011886760JJK
CWM TRACKING ID:	42916301
PROFILE #:	OR321468
LINE ITEM:	9b.1
QUANTITY:	1 DT
RECEIVED DATE:	10/09/13
DISPOSAL PROCESS(ES):	LANDFILL
FINAL DISPOSAL LOCATION:	LANDFILL 13
DISPOSAL DATE:	10/09/13

I certify, on behalf of the above listed treatment facility, that to the best of my knowledge, the above-described waste material was managed in compliance with all applicable laws, regulations, permits and licenses on the date listed above.

Bobbin Galvin

CWMNW RECORDS DEPARTMENT

Date: 10/15/13



CHEMICAL WASTE MANAGEMENT OF THE NW

17629 Cedar Springs Lane
Arlington, OR 97812
541 454 2643

PORT OF TACOMA
WAD001882984
3400 TAYLOR WAY
TACOMA WA 98421

CERTIFICATE OF DISPOSAL

Chemical Waste Management of the Northwest, Inc., ORD089452353, has received the following waste material:

GENERATOR:	PORT OF TACOMA
MANIFEST #:	011886748JJK
CWM TRACKING ID:	42913201
PROFILE #:	OR321468
LINE ITEM:	9b.1
QUANTITY:	1 DT
RECEIVED DATE:	10/09/13
DISPOSAL PROCESS(ES):	LANDFILL
FINAL DISPOSAL LOCATION:	LANDFILL 13
DISPOSAL DATE:	10/09/13

I certify, on behalf of the above listed treatment facility, that to the best of my knowledge, the above-described waste material was managed in compliance with all applicable laws, regulations, permits and licenses on the date listed above.

Robbi Jofalvin

CWMNW RECORDS DEPARTMENT

Date: 10/15/13



CHEMICAL WASTE MANAGEMENT OF THE NW

17629 Cedar Springs Lane
Arlington, OR 97812
541 454 2643

PORT OF TACOMA
WAD001882984
3400 TAYLOR WAY
TACOMA WA 98421

CERTIFICATE OF DISPOSAL

Chemical Waste Management of the Northwest, Inc., ORD089452353, has received the following waste material:

GENERATOR: PORT OF TACOMA
MANIFEST #: 011886751JJK
CWM TRACKING ID: 42913601
PROFILE #: OR321468
LINE ITEM: 9b.1
QUANTITY: 1 DT
RECEIVED DATE: 10/09/13

DISPOSAL PROCESS(ES): LANDFILL
FINAL DISPOSAL LOCATION: LANDFILL 13
DISPOSAL DATE: 10/09/13

I certify, on behalf of the above listed treatment facility, that to the best of my knowledge, the above-described waste material was managed in compliance with all applicable laws, regulations, permits and licenses on the date listed above.



CWMNW RECORDS DEPARTMENT

Date: 10/15/13



CHEMICAL WASTE MANAGEMENT OF THE NW

17629 Cedar Springs Lane
Arlington, OR 97812
541 454 2643

PORT OF TACOMA
WAD001882984
3400 TAYLOR WAY
TACOMA WA 98421

CERTIFICATE OF DISPOSAL

Chemical Waste Management of the Northwest, Inc., ORD089452353, has received the following waste material:

GENERATOR:	PORT OF TACOMA
MANIFEST #:	011886725JJK
CWM TRACKING ID:	42910501
PROFILE #:	OR321468
LINE ITEM:	9b.1
QUANTITY:	1 DT
RECEIVED DATE:	10/09/13
DISPOSAL PROCESS(ES):	LANDFILL
FINAL DISPOSAL LOCATION:	LANDFILL 13
DISPOSAL DATE:	10/09/13

I certify, on behalf of the above listed treatment facility, that to the best of my knowledge, the above-described waste material was managed in compliance with all applicable laws, regulations, permits and licenses on the date listed above.

Bobbi Jo Balvin

CWMNW RECORDS DEPARTMENT

Date: 10/15/13



CHEMICAL WASTE MANAGEMENT OF THE NW

17629 Cedar Springs Lane
Arlington, OR 97812
541 454 2643

PORT OF TACOMA
WAD001882984
3400 TAYLOR WAY
TACOMA WA 98421

CERTIFICATE OF DISPOSAL

Chemical Waste Management of the Northwest, Inc., ORD089452353, has received the following waste material:

GENERATOR:	PORT OF TACOMA
MANIFEST #:	011886749JJK
CWM TRACKING ID:	42913001
PROFILE #:	OR321468
LINE ITEM:	9b.1
QUANTITY:	1 DT
RECEIVED DATE:	10/09/13
DISPOSAL PROCESS(ES):	LANDFILL
FINAL DISPOSAL LOCATION:	LANDFILL 13
DISPOSAL DATE:	10/09/13

I certify, on behalf of the above listed treatment facility, that to the best of my knowledge, the above-described waste material was managed in compliance with all applicable laws, regulations, permits and licenses on the date listed above.

Bobbi Jo Galvin

CWMNW RECORDS DEPARTMENT

Date: 10/15/13



CHEMICAL WASTE MANAGEMENT OF THE NW

17629 Cedar Springs Lane
Arlington, OR 97812
541 454 2643

PORT OF TACOMA
WAD001882984
3400 TAYLOR WAY
TACOMA WA 98421

CERTIFICATE OF DISPOSAL

Chemical Waste Management of the Northwest, Inc., ORD089452353, has received the following waste material:

GENERATOR:	PORT OF TACOMA
MANIFEST #:	011886747JJK
CWM TRACKING ID:	42913101
PROFILE #:	OR321468
LINE ITEM:	9b.1
QUANTITY:	1 DT
RECEIVED DATE:	10/09/13
DISPOSAL PROCESS(ES):	LANDFILL
FINAL DISPOSAL LOCATION:	LANDFILL 13
DISPOSAL DATE:	10/09/13

I certify, on behalf of the above listed treatment facility, that to the best of my knowledge, the above-described waste material was managed in compliance with all applicable laws, regulations, permits and licenses on the date listed above.

Bobbi Jo Baker

CWMNW RECORDS DEPARTMENT

Date: 10/15/13



CHEMICAL WASTE MANAGEMENT OF THE NW

17629 Cedar Springs Lane
Arlington, OR 97812
541 454 2643

PORT OF TACOMA
WAD001882984
3400 TAYLOR WAY
TACOMA WA 98421

CERTIFICATE OF DISPOSAL

Chemical Waste Management of the Northwest, Inc., ORD089452353, has received the following waste material:

GENERATOR:	PORT OF TACOMA
MANIFEST #:	011186755JJK
CWM TRACKING ID:	42914901
PROFILE #:	OR321468
LINE ITEM:	9b.1
QUANTITY:	1 DT
RECEIVED DATE:	10/09/13
DISPOSAL PROCESS(ES):	LANDFILL
FINAL DISPOSAL LOCATION:	LANDFILL 13
DISPOSAL DATE:	10/09/13

I certify, on behalf of the above listed treatment facility, that to the best of my knowledge, the above-described waste material was managed in compliance with all applicable laws, regulations, permits and licenses on the date listed above.

Bobbi DeBralin

CWMNW RECORDS DEPARTMENT

Date: 10/16/13



CHEMICAL WASTE MANAGEMENT OF THE NW

17629 Cedar Springs Lane
Arlington, OR 97812
541 454 2643

PORT OF TACOMA
WAD001882984
3400 TAYLOR WAY
TACOMA WA 98421

CERTIFICATE OF DISPOSAL

Chemical Waste Management of the Northwest, Inc., ORD089452353, has received the following waste material:

GENERATOR:	PORT OF TACOMA
MANIFEST #:	011886757JJK
CWM TRACKING ID:	42916101
PROFILE #:	OR321468
LINE ITEM:	9b.1
QUANTITY:	1 DT
RECEIVED DATE:	10/09/13
DISPOSAL PROCESS(ES):	LANDFILL
FINAL DISPOSAL LOCATION:	LANDFILL 13
DISPOSAL DATE:	10/09/13

I certify, on behalf of the above listed treatment facility, that to the best of my knowledge, the above-described waste material was managed in compliance with all applicable laws, regulations, permits and licenses on the date listed above.

Bobbie Kralen

CWMNW RECORDS DEPARTMENT

Date: 10/16/13



CHEMICAL WASTE MANAGEMENT OF THE NW
17629 Cedar Springs Lane
Arlington, OR 97812
(541) 454-2643
(541) 454-3279 Fax

PORT OF TACOMA
WAD001882984
3400 TAYLOR WAY
TACOMA WA 98421

CERTIFICATE OF DISPOSAL

Chemical Waste Management of the Northwest, Inc., ORD089452353, has received the following waste material:

GENERATOR:	PORT OF TACOMA
MANIFEST #:	011888723JJK
CWM TRACKING ID:	429202-01
PROFILE #:	OR321488
LINE ITEM:	9b.1
QUANTITY:	1 DT
RECEIVED DATE:	10/10/13
DISPOSAL PROCESS(ES):	LANDFILL
FINAL DISPOSAL LOCATION:	LANDFILL 13
DISPOSAL DATE:	10/10/13

I certify, on behalf of the above listed treatment facility, that to the best of my knowledge, the above-described waste material was managed in compliance with all applicable laws, regulations, permits and licenses on the date listed above.



CWMNW RECORDS DEPARTMENT

Date: 10/15/13



CHEMICAL WASTE MANAGEMENT OF THE NW
17629 Cedar Springs Lane
Arlington, OR 97812
(541) 454-2643
(541) 454-3279 Fax

PORT OF TACOMA
WAD001882984
3400 TAYLOR WAY
TACOMA WA 98421

CERTIFICATE OF DISPOSAL

Chemical Waste Management of the Northwest, Inc., ORD089452353, has received the following waste material:

GENERATOR:	PORT OF TACOMA
MANIFEST #:	011886724JJK
CWM TRACKING ID:	429203-01
PROFILE #:	OR321468
LINE ITEM:	9b.1
QUANTITY:	1 DT
RECEIVED DATE:	10/10/13
DISPOSAL PROCESS(ES):	LANDFILL
FINAL DISPOSAL LOCATION:	LANDFILL 13
DISPOSAL DATE:	10/10/13

I certify, on behalf of the above listed treatment facility, that to the best of my knowledge, the above-described waste material was managed in compliance with all applicable laws, regulations, permits and licenses on the date listed above.



CWMNW RECORDS DEPARTMENT
Date: 10/15/13



CHEMICAL WASTE MANAGEMENT OF THE NW
 17629 Cedar Springs Lane
 Arlington, OR 97812
 (541) 454-2643
 (541) 454-3279 Fax

PORT OF TACOMA
 WAD001882984
 3400 TAYLOR WAY
 TACOMA WA 98421

CERTIFICATE OF DISPOSAL

Chemical Waste Management of the Northwest, Inc., ORD089452353, has received the following waste material:

GENERATOR:	PORT OF TACOMA	
MANIFEST #:	011886722JJK	
CWM TRACKING ID:	429204-01	
PROFILE #:	OR321468	
LINE ITEM:	9b.1	
QUANTITY:	1 DT	
RECEIVED DATE:	10/10/13	
DISPOSAL PROCESS(ES):	LANDFILL	
FINAL DISPOSAL LOCATION:	LANDFILL	13
DISPOSAL DATE:	10/10/13	

I certify, on behalf of the above listed treatment facility, that to the best of my knowledge, the above-described waste material was managed in compliance with all applicable laws, regulations, permits and licenses on the date listed above.

Becky Sumner

CWMNW RECORDS DEPARTMENT

Date: 10/15/13



CHEMICAL WASTE MANAGEMENT OF THE NW

17629 Cedar Springs Lane
Arlington, OR 97812
(541) 454-2643
(541) 454-3279 Fax

PORT OF TACOMA
WAD001882984
3400 TAYLOR WAY
TACOMA WA 98421

CERTIFICATE OF DISPOSAL

Chemical Waste Management of the Northwest, Inc., ORD089452353, has received the following waste material:

GENERATOR:	PORT OF TACOMA
MANIFEST #:	011886721JJK
CWM TRACKING ID:	429205-01
PROFILE #:	OR321468
LINE ITEM:	9b.1
QUANTITY:	1 DT
RECEIVED DATE:	10/10/13
DISPOSAL PROCESS(ES):	LANDFILL
FINAL DISPOSAL LOCATION:	LANDFILL 13
DISPOSAL DATE:	10/10/13

I certify, on behalf of the above listed treatment facility, that to the best of my knowledge, the above-described waste material was managed in compliance with all applicable laws, regulations, permits and licenses on the date listed above.



CWMNW RECORDS DEPARTMENT

Date: 10/15/13



CHEMICAL WASTE MANAGEMENT OF THE NW
 17629 Cedar Springs Lane
 Arlington, OR 97812
 (541) 454-2643
 (541) 454-3279 Fax

PORT OF TACOMA
 WAD001882984
 3400 TAYLOR WAY
 TACOMA WA 98421

CERTIFICATE OF DISPOSAL

Chemical Waste Management of the Northwest, Inc., ORD089452353, has received the following waste material:

GENERATOR:	PORT OF TACOMA
MANIFEST #:	011886719JJK
CWM TRACKING ID:	429210-01
PROFILE #:	OR321468
LINE ITEM:	9b.1
QUANTITY:	1 DT
RECEIVED DATE:	10/10/13
DISPOSAL PROCESS(ES):	LANDFILL
FINAL DISPOSAL LOCATION:	LANDFILL 13
DISPOSAL DATE:	10/10/13

I certify, on behalf of the above listed treatment facility, that to the best of my knowledge, the above-described waste material was managed in compliance with all applicable laws, regulations, permits and licenses on the date listed above.

Becky Sumner

CWMNW RECORDS DEPARTMENT
 Date: 10/15/13



CHEMICAL WASTE MANAGEMENT OF THE NW

17629 Cedar Springs Lane
Arlington, OR 97812
(541) 454-2643
(541) 454-3279 Fax

PORT OF TACOMA
WAD001882984
3400 TAYLOR WAY
TACOMA WA 98421

CERTIFICATE OF DISPOSAL

Chemical Waste Management of the Northwest, Inc., ORD089452353, has received the following waste material:

GENERATOR:	PORT OF TACOMA
MANIFEST #:	011886720JJK
CWM TRACKING ID:	429211-01
PROFILE #:	OR321468
LINE ITEM:	9b.1
QUANTITY:	1 DT
RECEIVED DATE:	10/10/13
DISPOSAL PROCESS(ES):	LANDFILL
FINAL DISPOSAL LOCATION:	LANDFILL 13
DISPOSAL DATE:	10/10/13

I certify, on behalf of the above listed treatment facility, that to the best of my knowledge, the above-described waste material was managed in compliance with all applicable laws, regulations, permits and licenses on the date listed above.



CWMNW RECORDS DEPARTMENT

Date: 10/15/13



CHEMICAL WASTE MANAGEMENT OF THE NW
17629 Cedar Springs Lane
Arlington, OR 97812
(541) 454-2643
(541) 454-3279 Fax

PORT OF TACOMA
WAD001882984
3400 TAYLOR WAY
TACOMA WA 98421

CERTIFICATE OF DISPOSAL

Chemical Waste Management of the Northwest, Inc., ORD089452353, has received the following waste material:

GENERATOR:	PORT OF TACOMA
MANIFEST #:	011886718JJK
CWM TRACKING ID:	429213-01
PROFILE #:	OR321468
LINE ITEM:	9b.1
QUANTITY:	1 DT
RECEIVED DATE:	10/10/13
DISPOSAL PROCESS(ES):	LANDFILL
FINAL DISPOSAL LOCATION:	LANDFILL 13
DISPOSAL DATE:	10/10/13

I certify, on behalf of the above listed treatment facility, that to the best of my knowledge, the above-described waste material was managed in compliance with all applicable laws, regulations, permits and licenses on the date listed above.

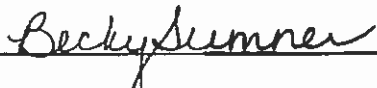

CWMNW RECORDS DEPARTMENT
Date: 10/15/13



CHEMICAL WASTE MANAGEMENT OF THE NW
17629 Cedar Springs Lane
Arlington, OR 97812
(541) 454-2643
(541) 454-3279 Fax

PORT OF TACOMA
WAD001882984
3400 TAYLOR WAY
TACOMA WA 98421

CERTIFICATE OF DISPOSAL

Chemical Waste Management of the Northwest, Inc., ORD089452353, has received the following waste material:

GENERATOR:	PORT OF TACOMA
MANIFEST #:	011886716JJK
CWM TRACKING ID:	429215-01
PROFILE #:	OR321488
LINE ITEM:	9b.1
QUANTITY:	1 DT
RECEIVED DATE:	10/10/13
DISPOSAL PROCESS(ES):	LANDFILL
FINAL DISPOSAL LOCATION:	LANDFILL 13
DISPOSAL DATE:	10/10/13

I certify, on behalf of the above listed treatment facility, that to the best of my knowledge, the above-described waste material was managed in compliance with all applicable laws, regulations, permits and licenses on the date listed above.



CWMNW RECORDS DEPARTMENT

Date: 10/15/13



CHEMICAL WASTE MANAGEMENT OF THE NW
17629 Cedar Springs Lane
Arlington, OR 97812
(541) 454-2643
(541) 454-3279 Fax

PORT OF TACOMA
WAD001882984
3400 TAYLOR WAY
TACOMA WA 98421

CERTIFICATE OF DISPOSAL

Chemical Waste Management of the Northwest, Inc., ORD089452353, has received the following waste material:

GENERATOR:	PORT OF TACOMA
MANIFEST #:	011886717JJK
CWM TRACKING ID:	429216-01
PROFILE #:	OR321488
LINE ITEM:	9b.1
QUANTITY:	1 DT
RECEIVED DATE:	10/10/13
DISPOSAL PROCESS(ES):	LANDFILL
FINAL DISPOSAL LOCATION:	LANDFILL 13
DISPOSAL DATE:	10/10/13

I certify, on behalf of the above listed treatment facility, that to the best of my knowledge, the above-described waste material was managed in compliance with all applicable laws, regulations, permits and licenses on the date listed above.

A handwritten signature in cursive script that reads "Becky Sumner".

CWMNW RECORDS DEPARTMENT

Date: 10/15/13



CHEMICAL WASTE MANAGEMENT OF THE NW
17629 Cedar Springs Lane
Arlington, OR 97812
(541) 454-2643
(541) 454-3279 Fax

PORT OF TACOMA
WAD001882984
3400 TAYLOR WAY
TACOMA WA 98421

CERTIFICATE OF DISPOSAL

Chemical Waste Management of the Northwest, Inc., ORD089452353, has received the following waste material:

GENERATOR:	PORT OF TACOMA
MANIFEST #:	011886789JJK
CWM TRACKING ID:	429221-01
PROFILE #:	OR321488
LINE ITEM:	9b.1
QUANTITY:	1 DT
RECEIVED DATE:	10/10/13
DISPOSAL PROCESS(ES):	LANDFILL
FINAL DISPOSAL LOCATION:	LANDFILL 13
DISPOSAL DATE:	10/10/13

I certify, on behalf of the above listed treatment facility, that to the best of my knowledge, the above-described waste material was managed in compliance with all applicable laws, regulations, permits and licenses on the date listed above.

Becky Sumner

CWMNW RECORDS DEPARTMENT

Date: 10/15/13



CHEMICAL WASTE MANAGEMENT OF THE NW

17629 Cedar Springs Lane
Arlington, OR 97812
(541) 454-2643
(541) 454-3279 Fax

PORT OF TACOMA
WAD001882984
3400 TAYLOR WAY
TACOMA WA 98421

CERTIFICATE OF DISPOSAL

Chemical Waste Management of the Northwest, Inc., ORD089452353, has received the following waste material:

GENERATOR:	PORT OF TACOMA
MANIFEST #:	011886779JJK
CWM TRACKING ID:	429223-01
PROFILE #:	OR321468
LINE ITEM:	9b.1
QUANTITY:	1 DT
RECEIVED DATE:	10/10/13
DISPOSAL PROCESS(ES):	LANDFILL
FINAL DISPOSAL LOCATION:	LANDFILL 13
DISPOSAL DATE:	10/10/13

I certify, on behalf of the above listed treatment facility, that to the best of my knowledge, the above-described waste material was managed in compliance with all applicable laws, regulations, permits and licenses on the date listed above.



CWMNW RECORDS DEPARTMENT
Date: 10/15/13



CHEMICAL WASTE MANAGEMENT OF THE NW
 17629 Cedar Springs Lane
 Arlington, OR 97812
 (541) 454-2643
 (541) 454-3279 Fax

PORT OF TACOMA
 WAD001882984
 3400 TAYLOR WAY
 TACOMA WA 98421

CERTIFICATE OF DISPOSAL

Chemical Waste Management of the Northwest, Inc., ORD089452353, has received the following waste material:

GENERATOR:	PORT OF TACOMA	
MANIFEST #:	011886781JJK	
CWM TRACKING ID:	429224-01	
PROFILE #:	OR321488	
LINE ITEM:	9b.1	
QUANTITY:	1 DT	
RECEIVED DATE:	10/10/13	
DISPOSAL PROCESS(ES):	LANDFILL	
FINAL DISPOSAL LOCATION:	LANDFILL	13
DISPOSAL DATE:	10/10/13	

I certify, on behalf of the above listed treatment facility, that to the best of my knowledge, the above-described waste material was managed in compliance with all applicable laws, regulations, permits and licenses on the date listed above.

Becky Sumner

CWMNW RECORDS DEPARTMENT

Date: 10/15/13



CHEMICAL WASTE MANAGEMENT OF THE NW

17629 Cedar Springs Lane
Arlington, OR 97812
(541) 454-2643
(541) 454-3279 Fax

PORT OF TACOMA
WAD001882984
3400 TAYLOR WAY
TACOMA WA 98421

CERTIFICATE OF DISPOSAL

Chemical Waste Management of the Northwest, Inc., ORD089452353, has received the following waste material:

GENERATOR:	PORT OF TACOMA
MANIFEST #:	011886780JJK
CWM TRACKING ID:	429226-01
PROFILE #:	OR321468
LINE ITEM:	9b.1
QUANTITY:	1 DT
RECEIVED DATE:	10/10/13
DISPOSAL PROCESS(ES):	LANDFILL
FINAL DISPOSAL LOCATION:	LANDFILL 13
DISPOSAL DATE:	10/10/13

I certify, on behalf of the above listed treatment facility, that to the best of my knowledge, the above-described waste material was managed in compliance with all applicable laws, regulations, permits and licenses on the date listed above.



CWMNW RECORDS DEPARTMENT
Date: 10/15/13



CHEMICAL WASTE MANAGEMENT OF THE NW
 17629 Cedar Springs Lane
 Arlington, OR 97812
 (541) 454-2643
 (541) 454-3279 Fax

PORT OF TACOMA
 WAD001882984
 3400 TAYLOR WAY
 TACOMA WA 98421

CERTIFICATE OF DISPOSAL

Chemical Waste Management of the Northwest, Inc., ORD089452353, has received the following waste material:

GENERATOR:	PORT OF TACOMA
MANIFEST #:	011886763JJK
CWM TRACKING ID:	429229-01
PROFILE #:	OR321468
LINE ITEM:	9b.1
QUANTITY:	1 DT
RECEIVED DATE:	10/10/13
DISPOSAL PROCESS(ES):	LANDFILL
FINAL DISPOSAL LOCATION:	LANDFILL 13
DISPOSAL DATE:	10/10/13

I certify, on behalf of the above listed treatment facility, that to the best of my knowledge, the above-described waste material was managed in compliance with all applicable laws, regulations, permits and licenses on the date listed above.

Becky Sumner

CWMNW RECORDS DEPARTMENT
 Date: 10/15/13



CHEMICAL WASTE MANAGEMENT OF THE NW

17629 Cedar Springs Lane
Arlington, OR 97812
(541) 454-2643
(541) 454-3279 Fax

PORT OF TACOMA
WAD001882984
3400 TAYLOR WAY
TACOMA WA 98421

CERTIFICATE OF DISPOSAL

Chemical Waste Management of the Northwest, Inc., ORD089452353, has received the following waste material:

GENERATOR:	PORT OF TACOMA
MANIFEST #:	011886762JJK
CWM TRACKING ID:	429230-01
PROFILE #:	OR321468
LINE ITEM:	9b.1
QUANTITY:	1 DT
RECEIVED DATE:	10/10/13
DISPOSAL PROCESS(ES):	LANDFILL
FINAL DISPOSAL LOCATION:	LANDFILL 13
DISPOSAL DATE:	10/10/13

I certify, on behalf of the above listed treatment facility, that to the best of my knowledge, the above-described waste material was managed in compliance with all applicable laws, regulations, permits and licenses on the date listed above.



CWMNW RECORDS DEPARTMENT

Date: 10/15/13



CHEMICAL WASTE MANAGEMENT OF THE NW

17629 Cedar Springs Lane
Arlington, OR 97812
541 454 2643

PORT OF TACOMA
WAD001882984
3400 TAYLOR WAY
TACOMA WA 98421

CERTIFICATE OF DISPOSAL

Chemical Waste Management of the Northwest, Inc., ORD089452353, has received the following waste material:

GENERATOR:	PORT OF TACOMA
MANIFEST #:	011886767JJK
CWM TRACKING ID:	42926101
PROFILE #:	OR321468
LINE ITEM:	9b.1
QUANTITY:	1 DT
RECEIVED DATE:	10/11/13
DISPOSAL PROCESS(ES):	LANDFILL
FINAL DISPOSAL LOCATION:	LANDFILL 13
DISPOSAL DATE:	10/11/13

I certify, on behalf of the above listed treatment facility, that to the best of my knowledge, the above-described waste material was managed in compliance with all applicable laws, regulations, permits and licenses on the date listed above.



CWMNW RECORDS DEPARTMENT

Date: 10/16/13



CHEMICAL WASTE MANAGEMENT OF THE NW

17629 Cedar Springs Lane
Arlington, OR 97812
541 454 2643

PORT OF TACOMA
WAD001882984
3400 TAYLOR WAY
TACOMA WA 98421

CERTIFICATE OF DISPOSAL

Chemical Waste Management of the Northwest, Inc., ORD089452353, has received the following waste material:

GENERATOR:	PORT OF TACOMA
MANIFEST #:	011886766JJK
CWM TRACKING ID:	42926201
PROFILE #:	OR321468
LINE ITEM:	9b.1
QUANTITY:	1 DT
RECEIVED DATE:	10/11/13

DISPOSAL PROCESS(ES):	LANDFILL	
FINAL DISPOSAL LOCATION:	LANDFILL	13
DISPOSAL DATE:	10/11/13	

I certify, on behalf of the above listed treatment facility, that to the best of my knowledge, the above-described waste material was managed in compliance with all applicable laws, regulations, permits and licenses on the date listed above.

CWMNW RECORDS DEPARTMENT

Date: 10/16/13



CHEMICAL WASTE MANAGEMENT OF THE NW

17629 Cedar Springs Lane
Arlington, OR 97812
541 454 2643

PORT OF TACOMA
WAD001882984
3400 TAYLOR WAY
TACOMA WA 98421

CERTIFICATE OF DISPOSAL

Chemical Waste Management of the Northwest, Inc., ORD089452353, has received the following waste material:

GENERATOR:	PORT OF TACOMA
MANIFEST #:	011886714JJK
CWM TRACKING ID:	42923701
PROFILE #:	OR321468
LINE ITEM:	9b.1
QUANTITY:	1 DT
RECEIVED DATE:	10/11/13
DISPOSAL PROCESS(ES):	LANDFILL
FINAL DISPOSAL LOCATION:	LANDFILL 13
DISPOSAL DATE:	10/11/13

I certify, on behalf of the above listed treatment facility, that to the best of my knowledge, the above-described waste material was managed in compliance with all applicable laws, regulations, permits and licenses on the date listed above.

Bobbi Sobralun

CWMNW RECORDS DEPARTMENT

Date: 10/16/13



CHEMICAL WASTE MANAGEMENT OF THE NW

17629 Cedar Springs Lane
Arlington, OR 97812
541 454 2643

PORT OF TACOMA
WAD001882984
3400 TAYLOR WAY
TACOMA WA 98421

CERTIFICATE OF DISPOSAL

Chemical Waste Management of the Northwest, Inc., ORD089452353, has received the following waste material:

GENERATOR:	PORT OF TACOMA
MANIFEST #:	011886705JJK
CWM TRACKING ID:	42925401
PROFILE #:	OR321468
LINE ITEM:	9b.1
QUANTITY:	1 DT
RECEIVED DATE:	10/11/13
DISPOSAL PROCESS(ES):	LANDFILL
FINAL DISPOSAL LOCATION:	LANDFILL 13
DISPOSAL DATE:	10/11/13

I certify, on behalf of the above listed treatment facility, that to the best of my knowledge, the above-described waste material was managed in compliance with all applicable laws, regulations, permits and licenses on the date listed above.

Bobbi Jobalvin

CWMNW RECORDS DEPARTMENT

Date: 10/16/13



CHEMICAL WASTE MANAGEMENT OF THE NW

17629 Cedar Springs Lane
Arlington, OR 97812
541 454 2643

PORT OF TACOMA
WAD001882984
3400 TAYLOR WAY
TACOMA WA 98421

CERTIFICATE OF DISPOSAL

Chemical Waste Management of the Northwest, Inc., ORD089452353, has received the following waste material:

GENERATOR:	PORT OF TACOMA
MANIFEST #:	011886710JJK
CWM TRACKING ID:	42925701
PROFILE #:	OR321468
LINE ITEM:	9b.1
QUANTITY:	1 DT
RECEIVED DATE:	10/11/13
DISPOSAL PROCESS(ES):	LANDFILL
FINAL DISPOSAL LOCATION:	LANDFILL 13
DISPOSAL DATE:	10/11/13

I certify, on behalf of the above listed treatment facility, that to the best of my knowledge, the above-described waste material was managed in compliance with all applicable laws, regulations, permits and licenses on the date listed above.

Bobbi Galun

CWMNW RECORDS DEPARTMENT

Date: 10/16/13



CHEMICAL WASTE MANAGEMENT OF THE NW

17629 Cedar Springs Lane
Arlington, OR 97812
541 454 2643

PORT OF TACOMA
WAD001882984
3400 TAYLOR WAY
TACOMA WA 98421

CERTIFICATE OF DISPOSAL

Chemical Waste Management of the Northwest, Inc., ORD089452353, has received the following waste material:

GENERATOR:	PORT OF TACOMA
MANIFEST #:	011886765JJK
CWM TRACKING ID:	42925901
PROFILE #:	OR321468
LINE ITEM:	9b.1
QUANTITY:	1 DT
RECEIVED DATE:	10/11/13
DISPOSAL PROCESS(ES):	LANDFILL
FINAL DISPOSAL LOCATION:	LANDFILL 13
DISPOSAL DATE:	10/11/13

I certify, on behalf of the above listed treatment facility, that to the best of my knowledge, the above-described waste material was managed in compliance with all applicable laws, regulations, permits and licenses on the date listed above.

Bobbie Galum

CWMNW RECORDS DEPARTMENT

Date: 10/16/13



CHEMICAL WASTE MANAGEMENT OF THE NW

17629 Cedar Springs Lane
Arlington, OR 97812
541 454 2643

PORT OF TACOMA
WAD001882984
3400 TAYLOR WAY
TACOMA WA 98421

CERTIFICATE OF DISPOSAL

Chemical Waste Management of the Northwest, Inc., ORD089452353, has received the following waste material:

GENERATOR:	PORT OF TACOMA
MANIFEST #:	011886768JJK
CWM TRACKING ID:	42927401
PROFILE #:	OR321468
LINE ITEM:	9b.1
QUANTITY:	1 DT
RECEIVED DATE:	10/11/13
DISPOSAL PROCESS(ES):	LANDFILL
FINAL DISPOSAL LOCATION:	LANDFILL 13
DISPOSAL DATE:	10/11/13

I certify, on behalf of the above listed treatment facility, that to the best of my knowledge, the above-described waste material was managed in compliance with all applicable laws, regulations, permits and licenses on the date listed above.

Bobbi So Galvin

CWMNW RECORDS DEPARTMENT

Date: 10/16/13



CHEMICAL WASTE MANAGEMENT OF THE NW

17629 Cedar Springs Lane
Arlington, OR 97812
541 454 2643

PORT OF TACOMA
WAD001882984
3400 TAYLOR WAY
TACOMA WA 98421

CERTIFICATE OF DISPOSAL

Chemical Waste Management of the Northwest, Inc., ORD089452353, has received the following waste material:

GENERATOR:	PORT OF TACOMA
MANIFEST #:	011886715JJK
CWM TRACKING ID:	42927601
PROFILE #:	OR321468
LINE ITEM:	9b.1
QUANTITY:	1 DT
RECEIVED DATE:	10/11/13

DISPOSAL PROCESS(ES):	LANDFILL	
FINAL DISPOSAL LOCATION:	LANDFILL	13
DISPOSAL DATE:	10/11/13	

I certify, on behalf of the above listed treatment facility, that to the best of my knowledge, the above-described waste material was managed in compliance with all applicable laws, regulations, permits and licenses on the date listed above.



CWMNW RECORDS DEPARTMENT

Date: 10/16/13



CHEMICAL WASTE MANAGEMENT OF THE NW

17629 Cedar Springs Lane
Arlington, OR 97812
541 454 2643

PORT OF TACOMA
WAD001882984
3400 TAYLOR WAY
TACOMA WA 98421

CERTIFICATE OF DISPOSAL

Chemical Waste Management of the Northwest, Inc., ORD089452353, has received the following waste material:

GENERATOR:	PORT OF TACOMA
MANIFEST #:	011886707JJK
CWM TRACKING ID:	42927701
PROFILE #:	OR321468
LINE ITEM:	9b.1
QUANTITY:	1 DT
RECEIVED DATE:	10/11/13
DISPOSAL PROCESS(ES):	LANDFILL
FINAL DISPOSAL LOCATION:	LANDFILL 13
DISPOSAL DATE:	10/11/13

I certify, on behalf of the above listed treatment facility, that to the best of my knowledge, the above-described waste material was managed in compliance with all applicable laws, regulations, permits and licenses on the date listed above.



CWMNW RECORDS DEPARTMENT

Date: 10/16/13



CHEMICAL WASTE MANAGEMENT OF THE NW

17629 Cedar Springs Lane
Arlington, OR 97812
541 454 2643

PORT OF TACOMA
WAD001882984
3400 TAYLOR WAY
TACOMA WA 98421

CERTIFICATE OF DISPOSAL

Chemical Waste Management of the Northwest, Inc., ORD089452353, has received the following waste material:

GENERATOR: PORT OF TACOMA
MANIFEST #: 011886764JJK
CWM TRACKING ID: 42927801
PROFILE #: OR321468
LINE ITEM: 9b.1
QUANTITY: 1 DT
RECEIVED DATE: 10/11/13

DISPOSAL PROCESS(ES): LANDFILL
FINAL DISPOSAL LOCATION: LANDFILL 13
DISPOSAL DATE: 10/11/13

I certify, on behalf of the above listed treatment facility, that to the best of my knowledge, the above-described waste material was managed in compliance with all applicable laws, regulations, permits and licenses on the date listed above.



CWMNW RECORDS DEPARTMENT

Date: 10/16/13



CHEMICAL WASTE MANAGEMENT OF THE NW

17629 Cedar Springs Lane
Arlington, OR 97812
541 454 2643

PORT OF TACOMA
WAD001882984
3400 TAYLOR WAY
TACOMA WA 98421

CERTIFICATE OF DISPOSAL

Chemical Waste Management of the Northwest, Inc., ORD089452353, has received the following waste material:

GENERATOR:	PORT OF TACOMA
MANIFEST #:	011886708JJK
CWM TRACKING ID:	42927901
PROFILE #:	OR321468
LINE ITEM:	9b.1
QUANTITY:	1 DT
RECEIVED DATE:	10/11/13
DISPOSAL PROCESS(ES):	LANDFILL
FINAL DISPOSAL LOCATION:	LANDFILL 13
DISPOSAL DATE:	10/11/13

I certify, on behalf of the above listed treatment facility, that to the best of my knowledge, the above-described waste material was managed in compliance with all applicable laws, regulations, permits and licenses on the date listed above.



CWMNW RECORDS DEPARTMENT

Date: 10/16/13



CHEMICAL WASTE MANAGEMENT OF THE NW

17629 Cedar Springs Lane
Arlington, OR 97812
541 454 2643

PORT OF TACOMA
WAD001882984
3400 TAYLOR WAY
TACOMA WA 98421

CERTIFICATE OF DISPOSAL

Chemical Waste Management of the Northwest, Inc., ORD089452353, has received the following waste material:

GENERATOR:	PORT OF TACOMA
MANIFEST #:	011886709JJK
CWM TRACKING ID:	42928001
PROFILE #:	OR321468
LINE ITEM:	9b.1
QUANTITY:	1 DT
RECEIVED DATE:	10/11/13
DISPOSAL PROCESS(ES):	LANDFILL
FINAL DISPOSAL LOCATION:	LANDFILL 13
DISPOSAL DATE:	10/11/13

I certify, on behalf of the above listed treatment facility, that to the best of my knowledge, the above-described waste material was managed in compliance with all applicable laws, regulations, permits and licenses on the date listed above.



CWMNW RECORDS DEPARTMENT

Date: 10/16/13



CHEMICAL WASTE MANAGEMENT OF THE NW

17629 Cedar Springs Lane
Arlington, OR 97812
541 454 2643

PORT OF TACOMA
WAD001882984
3400 TAYLOR WAY
TACOMA WA 98421

CERTIFICATE OF DISPOSAL

Chemical Waste Management of the Northwest, Inc., ORD089452353, has received the following waste material:

GENERATOR:	PORT OF TACOMA
MANIFEST #:	011886706JJK
CWM TRACKING ID:	42928501
PROFILE #:	OR321468
LINE ITEM:	9b.1
QUANTITY:	1 DT
RECEIVED DATE:	10/11/13
DISPOSAL PROCESS(ES):	LANDFILL
FINAL DISPOSAL LOCATION:	LANDFILL 13
DISPOSAL DATE:	10/11/13

I certify, on behalf of the above listed treatment facility, that to the best of my knowledge, the above-described waste material was managed in compliance with all applicable laws, regulations, permits and licenses on the date listed above.



CWMNW RECORDS DEPARTMENT

Date: 10/16/13



CHEMICAL WASTE MANAGEMENT OF THE NW

17629 Cedar Springs Lane
Arlington, OR 97812
541 454 2643

PORT OF TACOMA
WAD001882984
3400 TAYLOR WAY
TACOMA WA 98421

CERTIFICATE OF DISPOSAL

Chemical Waste Management of the Northwest, Inc., ORD089452353, has received the following waste material:

GENERATOR:	PORT OF TACOMA	
MANIFEST #:	011086713JJK	
CWM TRACKING ID:	42928601	
PROFILE #:	OR321468	
LINE ITEM:	9b.1	
QUANTITY:	1 DT	
RECEIVED DATE:	10/11/13	
DISPOSAL PROCESS(ES):	LANDFILL	
FINAL DISPOSAL LOCATION:	LANDFILL	13
DISPOSAL DATE:	10/11/13	

I certify, on behalf of the above listed treatment facility, that to the best of my knowledge, the above-described waste material was managed in compliance with all applicable laws, regulations, permits and licenses on the date listed above.

Bobbi Jo Galvin

CWMNW RECORDS DEPARTMENT

Date: 10/16/13



CHEMICAL WASTE MANAGEMENT OF THE NW

17629 Cedar Springs Lane
Arlington, OR 97812
541 454 2643

PORT OF TACOMA
WAD001882984
3400 TAYLOR WAY
TACOMA WA 98421

CERTIFICATE OF DISPOSAL

Chemical Waste Management of the Northwest, Inc., ORD089452353, has received the following waste material:

GENERATOR:	PORT OF TACOMA
MANIFEST #:	011886711JJK
CWM TRACKING ID:	42929201
PROFILE #:	OR321468
LINE ITEM:	9b.1
QUANTITY:	1 DT
RECEIVED DATE:	10/11/13
DISPOSAL PROCESS(ES):	LANDFILL
FINAL DISPOSAL LOCATION:	LANDFILL 13
DISPOSAL DATE:	10/11/13

I certify, on behalf of the above listed treatment facility, that to the best of my knowledge, the above-described waste material was managed in compliance with all applicable laws, regulations, permits and licenses on the date listed above.

Bobbi Behr

CWMNW RECORDS DEPARTMENT

Date: 10/16/13



CHEMICAL WASTE MANAGEMENT OF THE NW

17629 Cedar Springs Lane
Arlington, OR 97812
541 454 2643

PORT OF TACOMA
WAD001882984
3400 TAYLOR WAY
TACOMA WA 98421

CERTIFICATE OF DISPOSAL

Chemical Waste Management of the Northwest, Inc., ORD089452353, has received the following waste material:

GENERATOR:	PORT OF TACOMA
MANIFEST #:	011886703JJK
CWM TRACKING ID:	42929401
PROFILE #:	OR321468
LINE ITEM:	9b.1
QUANTITY:	1 DT
RECEIVED DATE:	10/11/13
DISPOSAL PROCESS(ES):	LANDFILL
FINAL DISPOSAL LOCATION:	LANDFILL 13
DISPOSAL DATE:	10/11/13

I certify, on behalf of the above listed treatment facility, that to the best of my knowledge, the above-described waste material was managed in compliance with all applicable laws, regulations, permits and licenses on the date listed above.

Bobbi Galvin

CWMNW RECORDS DEPARTMENT

Date: 10/16/13



CHEMICAL WASTE MANAGEMENT OF THE NW

17629 Cedar Springs Lane
Arlington, OR 97812
541 454 2643

PORT OF TACOMA
WAD001882984
3400 TAYLOR WAY
TACOMA WA 98421

CERTIFICATE OF DISPOSAL

Chemical Waste Management of the Northwest, Inc., ORD089452353, has received the following waste material:

GENERATOR:	PORT OF TACOMA
MANIFEST #:	011886712JJK
CWM TRACKING ID:	42929501
PROFILE #:	OR321468
LINE ITEM:	9b.1
QUANTITY:	1 DT
RECEIVED DATE:	10/11/13
DISPOSAL PROCESS(ES):	LANDFILL
FINAL DISPOSAL LOCATION:	LANDFILL 13
DISPOSAL DATE:	10/11/13

I certify, on behalf of the above listed treatment facility, that to the best of my knowledge, the above-described waste material was managed in compliance with all applicable laws, regulations, permits and licenses on the date listed above.



CWMNW RECORDS DEPARTMENT

Date: 10/15/13



CHEMICAL WASTE MANAGEMENT OF THE NW

17629 Cedar Springs Lane
Arlington, OR 97812
541 454 2643

PORT OF TACOMA
WAD001882984
3400 TAYLOR WAY
TACOMA WA 98421

CERTIFICATE OF DISPOSAL

Chemical Waste Management of the Northwest, Inc., ORD089452353, has received the following waste material:

GENERATOR:	PORT OF TACOMA
MANIFEST #:	011886702JJK
CWM TRACKING ID:	42929801
PROFILE #:	OR321468
LINE ITEM:	9b.1
QUANTITY:	1 DT
RECEIVED DATE:	10/11/13
DISPOSAL PROCESS(ES):	LANDFILL
FINAL DISPOSAL LOCATION:	LANDFILL 13
DISPOSAL DATE:	10/11/13

I certify, on behalf of the above listed treatment facility, that to the best of my knowledge, the above-described waste material was managed in compliance with all applicable laws, regulations, permits and licenses on the date listed above.

Robbie Galvin

CWMNW RECORDS DEPARTMENT

Date: 10/16/13



CHEMICAL WASTE MANAGEMENT OF THE NW

17629 Cedar Springs Lane
Arlington, OR 97812
541 454 2643

PORT OF TACOMA
WAD001882984
3400 TAYLOR WAY
TACOMA WA 98421

CERTIFICATE OF DISPOSAL

Chemical Waste Management of the Northwest, Inc., ORD089452353, has received the following waste material:

GENERATOR:	PORT OF TACOMA
MANIFEST #:	011886704JJK
CWM TRACKING ID:	42926001
PROFILE #:	OR321468
LINE ITEM:	9b.1
QUANTITY:	1 DT
RECEIVED DATE:	10/11/13
DISPOSAL PROCESS(ES):	LANDFILL
FINAL DISPOSAL LOCATION:	LANDFILL 13
DISPOSAL DATE:	10/11/13

I certify, on behalf of the above listed treatment facility, that to the best of my knowledge, the above-described waste material was managed in compliance with all applicable laws, regulations, permits and licenses on the date listed above.

Bobbi Bralun

CWMNW RECORDS DEPARTMENT

Date: 10/16/13



CHEMICAL WASTE MANAGEMENT OF THE NW
 17629 Cedar Springs Lane
 Arlington, OR 97812
 (541) 454-2643
 (541) 454-3279 Fax

PORT OF TACOMA
 WAD001882984
 3400 TAYLOR WAY
 TACOMA WA 98421

CERTIFICATE OF DISPOSAL

Chemical Waste Management of the Northwest, Inc., ORD089452353, has received the following waste material:

GENERATOR:	PORT OF TACOMA	
MANIFEST #:	011886681JJK	
CWM TRACKING ID:	429320-01	
PROFILE #:	OR321468	
LINE ITEM:	9b.1	
QUANTITY:	1 DT	
RECEIVED DATE:	10/14/13	
DISPOSAL PROCESS(ES):	LANDFILL	
FINAL DISPOSAL LOCATION:	LANDFILL	13
DISPOSAL DATE:	10/14/13	

I certify, on behalf of the above listed treatment facility, that to the best of my knowledge, the above-described waste material was managed in compliance with all applicable laws, regulations, permits and licenses on the date listed above.

Becky Sumner

CWMNW RECORDS DEPARTMENT

Date: 10/16/13



CHEMICAL WASTE MANAGEMENT OF THE NW
17629 Cedar Springs Lane
Arlington, OR 97812
(541) 454-2643
(541) 454-3279 Fax

PORT OF TACOMA
WAD001882984
3400 TAYLOR WAY
TACOMA WA 98421

CERTIFICATE OF DISPOSAL

Chemical Waste Management of the Northwest, Inc., ORD089452353, has received the following waste material:

GENERATOR:	PORT OF TACOMA
MANIFEST #:	011886680JJK
CWM TRACKING ID:	429321-01
PROFILE #:	OR321468
LINE ITEM:	9b.1
QUANTITY:	1 DT
RECEIVED DATE:	10/14/13
DISPOSAL PROCESS(ES):	LANDFILL
FINAL DISPOSAL LOCATION:	LANDFILL 13
DISPOSAL DATE:	10/14/13

I certify, on behalf of the above listed treatment facility, that to the best of my knowledge, the above-described waste material was managed in compliance with all applicable laws, regulations, permits and licenses on the date listed above.



CWMNW RECORDS DEPARTMENT

Date: 10/16/13



CHEMICAL WASTE MANAGEMENT OF THE NW

17629 Cedar Springs Lane
Arlington, OR 97812
(541) 454-2643
(541) 454-3279 Fax

PORT OF TACOMA
WAD001882984
3400 TAYLOR WAY
TACOMA WA 98421

CERTIFICATE OF DISPOSAL

Chemical Waste Management of the Northwest, Inc., ORD089452353, has received the following waste material:

GENERATOR:	PORT OF TACOMA
MANIFEST #:	011886682JJK
CWM TRACKING ID:	429322-01
PROFILE #:	OR321468
LINE ITEM:	9b.1
QUANTITY:	1 DT
RECEIVED DATE:	10/14/13
DISPOSAL PROCESS(ES):	LANDFILL
FINAL DISPOSAL LOCATION:	LANDFILL 13
DISPOSAL DATE:	10/14/13

I certify, on behalf of the above listed treatment facility, that to the best of my knowledge, the above-described waste material was managed in compliance with all applicable laws, regulations, permits and licenses on the date listed above.

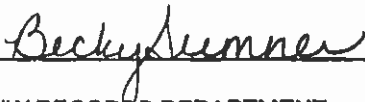

CWMNW RECORDS DEPARTMENT

Date: 10/16/13



CHEMICAL WASTE MANAGEMENT OF THE NW
 17629 Cedar Springs Lane
 Arlington, OR 97812
 (541) 454-2643
 (541) 454-3279 Fax

PORT OF TACOMA
 WAD001882984
 3400 TAYLOR WAY
 TACOMA WA 98421

CERTIFICATE OF DISPOSAL

Chemical Waste Management of the Northwest, Inc., ORD089452353, has received the following waste material:

GENERATOR:	PORT OF TACOMA	
MANIFEST #:	011886701JJK	
CWM TRACKING ID:	429325-01	
PROFILE #:	OR321468	
LINE ITEM:	9b.1	
QUANTITY:	1 DT	
RECEIVED DATE:	10/14/13	
DISPOSAL PROCESS(ES):	LANDFILL	
FINAL DISPOSAL LOCATION:	LANDFILL	13
DISPOSAL DATE:	10/14/13	

I certify, on behalf of the above listed treatment facility, that to the best of my knowledge, the above-described waste material was managed in compliance with all applicable laws, regulations, permits and licenses on the date listed above.

Becky Sumner

CWMNW RECORDS DEPARTMENT

Date: 10/16/13



CHEMICAL WASTE MANAGEMENT OF THE NW
17629 Cedar Springs Lane
Arlington, OR 97812
(541) 454-2643
(541) 454-3279 Fax

PORT OF TACOMA
WAD001882984
3400 TAYLOR WAY
TACOMA WA 98421

CERTIFICATE OF DISPOSAL

Chemical Waste Management of the Northwest, Inc., ORD089452353, has received the following waste material:

GENERATOR:	PORT OF TACOMA
MANIFEST #:	011886883JJK
CWM TRACKING ID:	429326-01
PROFILE #:	OR321468
LINE ITEM:	9b.1
QUANTITY:	1 DT
RECEIVED DATE:	10/14/13
DISPOSAL PROCESS(ES):	LANDFILL
FINAL DISPOSAL LOCATION:	LANDFILL 13
DISPOSAL DATE:	10/14/13

I certify, on behalf of the above listed treatment facility, that to the best of my knowledge, the above-described waste material was managed in compliance with all applicable laws, regulations, permits and licenses on the date listed above.

A handwritten signature in cursive script that reads "Becky Sumner".

CWMNW RECORDS DEPARTMENT

Date: 10/16/13



CHEMICAL WASTE MANAGEMENT OF THE NW

17629 Cedar Springs Lane
Arlington, OR 97812
(541) 454-2643
(541) 454-3279 Fax

PORT OF TACOMA
WAD001882984
3400 TAYLOR WAY
TACOMA WA 98421

CERTIFICATE OF DISPOSAL

Chemical Waste Management of the Northwest, Inc., ORD089452353, has received the following waste material:

GENERATOR:	PORT OF TACOMA
MANIFEST #:	01188884JJK
CWM TRACKING ID:	429327-01
PROFILE #:	OR321468
LINE ITEM:	9b.1
QUANTITY:	1 DT
RECEIVED DATE:	10/14/13
DISPOSAL PROCESS(ES):	LANDFILL
FINAL DISPOSAL LOCATION:	LANDFILL 13
DISPOSAL DATE:	10/14/13

I certify, on behalf of the above listed treatment facility, that to the best of my knowledge, the above-described waste material was managed in compliance with all applicable laws, regulations, permits and licenses on the date listed above.



CWMNW RECORDS DEPARTMENT

Date: 10/16/13



CHEMICAL WASTE MANAGEMENT OF THE NW
17629 Cedar Springs Lane
Arlington, OR 97812
(541) 454-2643
(541) 454-3279 Fax

PORT OF TACOMA
WAD001882984
3400 TAYLOR WAY
TACOMA WA 98421

CERTIFICATE OF DISPOSAL

Chemical Waste Management of the Northwest, Inc., ORD089452353, has received the following waste material:

GENERATOR:	PORT OF TACOMA
MANIFEST #:	011886679JJK
CWM TRACKING ID:	428328-01
PROFILE #:	OR321468
LINE ITEM:	9b.1
QUANTITY:	1 DT
RECEIVED DATE:	10/14/13
DISPOSAL PROCESS(ES):	LANDFILL
FINAL DISPOSAL LOCATION:	LANDFILL 13
DISPOSAL DATE:	10/14/13

I certify, on behalf of the above listed treatment facility, that to the best of my knowledge, the above-described waste material was managed in compliance with all applicable laws, regulations, permits and licenses on the date listed above.

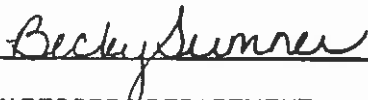

CWMNW RECORDS DEPARTMENT

Date: 10/16/13



CHEMICAL WASTE MANAGEMENT OF THE NW

17629 Cedar Springs Lane
Arlington, OR 97812
(541) 454-2643
(541) 454-3279 Fax

PORT OF TACOMA
WAD001882984
3400 TAYLOR WAY
TACOMA WA 98421

CERTIFICATE OF DISPOSAL

Chemical Waste Management of the Northwest, Inc., ORD089452353, has received the following waste material:

GENERATOR:	PORT OF TACOMA
MANIFEST #:	011886678JJK
CWM TRACKING ID:	429329-01
PROFILE #:	OR321468
LINE ITEM:	9b.1
QUANTITY:	1 DT
RECEIVED DATE:	10/14/13
DISPOSAL PROCESS(ES):	LANDFILL
FINAL DISPOSAL LOCATION:	LANDFILL 13
DISPOSAL DATE:	10/14/13

I certify, on behalf of the above listed treatment facility, that to the best of my knowledge, the above-described waste material was managed in compliance with all applicable laws, regulations, permits and licenses on the date listed above.



CWMNW RECORDS DEPARTMENT

Date: 10/16/13



CHEMICAL WASTE MANAGEMENT OF THE NW

17629 Cedar Springs Lane
Arlington, OR 97812
(541) 454-2643
(541) 454-3279 Fax

PORT OF TACOMA
WAD001882984
3400 TAYLOR WAY
TACOMA WA 98421

CERTIFICATE OF DISPOSAL

Chemical Waste Management of the Northwest, Inc., ORD089452353, has received the following waste material:

GENERATOR:	PORT OF TACOMA
MANIFEST #:	011886687JJK
CWM TRACKING ID:	429331-01
PROFILE #:	OR321468
LINE ITEM:	9b.1
QUANTITY:	1 DT
RECEIVED DATE:	10/14/13
DISPOSAL PROCESS(ES):	LANDFILL
FINAL DISPOSAL LOCATION:	LANDFILL 13
DISPOSAL DATE:	10/14/13

I certify, on behalf of the above listed treatment facility, that to the best of my knowledge, the above-described waste material was managed in compliance with all applicable laws, regulations, permits and licenses on the date listed above.

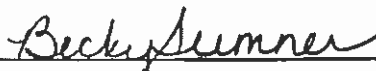

CWMNW RECORDS DEPARTMENT

Date: 10/16/13



CHEMICAL WASTE MANAGEMENT OF THE NW
 17629 Cedar Springs Lane
 Arlington, OR 97812
 (541) 454-2643
 (541) 454-3279 Fax

PORT OF TACOMA
 WAD001882984
 3400 TAYLOR WAY
 TACOMA WA 98421

CERTIFICATE OF DISPOSAL

Chemical Waste Management of the Northwest, Inc., ORD089452353, has received the following waste material:

GENERATOR:	PORT OF TACOMA	
MANIFEST #:	011886688JJK	
CWM TRACKING ID:	429335-01	
PROFILE #:	OR321468	
LINE ITEM:	9b.1	
QUANTITY:	1 DT	
RECEIVED DATE:	10/14/13	
DISPOSAL PROCESS(ES):	LANDFILL	
FINAL DISPOSAL LOCATION:	LANDFILL	13
DISPOSAL DATE:	10/14/13	

I certify, on behalf of the above listed treatment facility, that to the best of my knowledge, the above-described waste material was managed in compliance with all applicable laws, regulations, permits and licenses on the date listed above.



CWMNW RECORDS DEPARTMENT
 Date: 10/16/13



CHEMICAL WASTE MANAGEMENT OF THE NW
 17629 Cedar Springs Lane
 Arlington, OR 97812
 (541) 454-2643
 (541) 454-3279 Fax

PORT OF TACOMA
 WAD001882984
 3400 TAYLOR WAY
 TACOMA WA 98421

CERTIFICATE OF DISPOSAL

Chemical Waste Management of the Northwest, Inc., ORD089452353, has received the following waste material:

GENERATOR:	PORT OF TACOMA	
MANIFEST #:	011886688JJK	
CWM TRACKING ID:	429336-01	
PROFILE #:	OR321468	
LINE ITEM:	9b.1	
QUANTITY:	1 DT	
RECEIVED DATE:	10/14/13	
DISPOSAL PROCESS(ES):	LANDFILL	
FINAL DISPOSAL LOCATION:	LANDFILL	13
DISPOSAL DATE:	10/14/13	

I certify, on behalf of the above listed treatment facility, that to the best of my knowledge, the above-described waste material was managed in compliance with all applicable laws, regulations, permits and licenses on the date listed above.

Becky Sumner

CWMNW RECORDS DEPARTMENT
 Date: 10/16/13



CHEMICAL WASTE MANAGEMENT OF THE NW

17629 Cedar Springs Lane
Arlington, OR 97812
(541) 454-2643
(541) 454-3279 Fax

PORT OF TACOMA
WAD001882984
3400 TAYLOR WAY
TACOMA WA 98421

CERTIFICATE OF DISPOSAL

Chemical Waste Management of the Northwest, Inc., ORD089452353, has received the following waste material:

GENERATOR:	PORT OF TACOMA
MANIFEST #:	011886885JJK
CWM TRACKING ID:	428337-01
PROFILE #:	OR321488
LINE ITEM:	9b.1
QUANTITY:	1 DT
RECEIVED DATE:	10/14/13
DISPOSAL PROCESS(ES):	LANDFILL
FINAL DISPOSAL LOCATION:	LANDFILL 13
DISPOSAL DATE:	10/14/13

I certify, on behalf of the above listed treatment facility, that to the best of my knowledge, the above-described waste material was managed in compliance with all applicable laws, regulations, permits and licenses on the date listed above.



CWMNW RECORDS DEPARTMENT

Date: 10/16/13



CHEMICAL WASTE MANAGEMENT OF THE NW
17629 Cedar Springs Lane
Arlington, OR 97812
(541) 454-2643
(541) 454-3279 Fax

PORT OF TACOMA
WAD001882984
3400 TAYLOR WAY
TACOMA WA 98421

CERTIFICATE OF DISPOSAL

Chemical Waste Management of the Northwest, Inc., ORD089452353, has received the following waste material:

GENERATOR:	PORT OF TACOMA
MANIFEST #:	011886688JJK
CWM TRACKING ID:	429341-01
PROFILE #:	OR321468
LINE ITEM:	9b.1
QUANTITY:	1 DT
RECEIVED DATE:	10/14/13
DISPOSAL PROCESS(ES):	LANDFILL
FINAL DISPOSAL LOCATION:	LANDFILL 13
DISPOSAL DATE:	10/14/13

I certify, on behalf of the above listed treatment facility, that to the best of my knowledge, the above-described waste material was managed in compliance with all applicable laws, regulations, permits and licenses on the date listed above.



CWMNW RECORDS DEPARTMENT

Date: 10/16/13



CHEMICAL WASTE MANAGEMENT OF THE NW
 17629 Cedar Springs Lane
 Arlington, OR 97812
 (541) 454-2643
 (541) 454-3279 Fax

PORT OF TACOMA
 WAD001882984
 3400 TAYLOR WAY
 TACOMA WA 98421

CERTIFICATE OF DISPOSAL

Chemical Waste Management of the Northwest, Inc., ORD089452353, has received the following waste material:

GENERATOR:	PORT OF TACOMA	
MANIFEST #:	011886690JJK	
CWM TRACKING ID:	429350-01	
PROFILE #:	OR321468	
LINE ITEM:	9b.1	
QUANTITY:	1 DT	
RECEIVED DATE:	10/14/13	
DISPOSAL PROCESS(ES):	LANDFILL	
FINAL DISPOSAL LOCATION:	LANDFILL	13
DISPOSAL DATE:	10/14/13	

I certify, on behalf of the above listed treatment facility, that to the best of my knowledge, the above-described waste material was managed in compliance with all applicable laws, regulations, permits and licenses on the date listed above.

Becky Sumner

CWMNW RECORDS DEPARTMENT

Date: 10/16/13



CHEMICAL WASTE MANAGEMENT OF THE NW

17629 Cedar Springs Lane
Arlington, OR 97812
(541) 454-2643
(541) 454-3279 Fax

PORT OF TACOMA
WAD001882984
3400 TAYLOR WAY
TACOMA WA 98421

CERTIFICATE OF DISPOSAL

Chemical Waste Management of the Northwest, Inc., ORD089452353, has received the following waste material:

GENERATOR:	PORT OF TACOMA
MANIFEST #:	011886692JJK
CWM TRACKING ID:	429355-01
PROFILE #:	OR321468
LINE ITEM:	9b.1
QUANTITY:	1 DT
RECEIVED DATE:	10/14/13
DISPOSAL PROCESS(ES):	LANDFILL
FINAL DISPOSAL LOCATION:	LANDFILL 13
DISPOSAL DATE:	10/14/13

I certify, on behalf of the above listed treatment facility, that to the best of my knowledge, the above-described waste material was managed in compliance with all applicable laws, regulations, permits and licenses on the date listed above.



CWMNW RECORDS DEPARTMENT

Date: 10/16/13



CHEMICAL WASTE MANAGEMENT OF THE NW

17629 Cedar Springs Lane
Arlington, OR 97812
541 454 2643

PORT OF TACOMA
WAD001882984
3400 TAYLOR WAY
TACOMA WA 98421

CERTIFICATE OF DISPOSAL

Chemical Waste Management of the Northwest, Inc., ORD089452353, has received the following waste material:

GENERATOR:	PORT OF TACOMA
MANIFEST #:	011886691JJK
CWM TRACKING ID:	42933801
PROFILE #:	OR321468
LINE ITEM:	9b.1
QUANTITY:	1 DT
RECEIVED DATE:	10/14/13
DISPOSAL PROCESS(ES):	LANDFILL
FINAL DISPOSAL LOCATION:	LANDFILL 13
DISPOSAL DATE:	10/14/13

I certify, on behalf of the above listed treatment facility, that to the best of my knowledge, the above-described waste material was managed in compliance with all applicable laws, regulations, permits and licenses on the date listed above.



CWMNW RECORDS DEPARTMENT
Date:

10/21/13



CHEMICAL WASTE MANAGEMENT OF THE NW

17629 Cedar Springs Lane
Arlington, OR 97812
541 454 2643

PORT OF TACOMA
WAD001882984
3400 TAYLOR WAY
TACOMA WA 98421

CERTIFICATE OF DISPOSAL

Chemical Waste Management of the Northwest, Inc., ORD089452353, has received the following waste material:

GENERATOR:	PORT OF TACOMA
MANIFEST #:	011886670JJK
CWM TRACKING ID:	42941601
PROFILE #:	OR321468
LINE ITEM:	9b.1
QUANTITY:	1 DT
RECEIVED DATE:	10/15/13

DISPOSAL PROCESS(ES):	LANDFILL	
FINAL DISPOSAL LOCATION:	LANDFILL	13
DISPOSAL DATE:	10/15/13	

I certify, on behalf of the above listed treatment facility, that to the best of my knowledge, the above-described waste material was managed in compliance with all applicable laws, regulations, permits and licenses on the date listed above.



CWMNW RECORDS DEPARTMENT

Date: 10/21/13



CHEMICAL WASTE MANAGEMENT OF THE NW

17629 Cedar Springs Lane
Arlington, OR 97812
541 454 2643

PORT OF TACOMA
WAD001882984
3400 TAYLOR WAY
TACOMA WA 98421

CERTIFICATE OF DISPOSAL

Chemical Waste Management of the Northwest, Inc., ORD089452353, has received the following waste material:

GENERATOR:	PORT OF TACOMA
MANIFEST #:	011886700JJK
CWM TRACKING ID:	429379010
PROFILE #:	OR321468
LINE ITEM:	9b.1
QUANTITY:	1 DT
RECEIVED DATE:	10/15/13
DISPOSAL PROCESS(ES):	LANDFILL
FINAL DISPOSAL LOCATION:	LANDFILL 13
DISPOSAL DATE:	10/15/13

I certify, on behalf of the above listed treatment facility, that to the best of my knowledge, the above-described waste material was managed in compliance with all applicable laws, regulations, permits and licenses on the date listed above.

Bobbi J. Galum

CWMNW RECORDS DEPARTMENT

Date: 10/21/13



CHEMICAL WASTE MANAGEMENT OF THE NW
17629 Cedar Springs Lane
Arlington, OR 97812
541 454 2643

PORT OF TACOMA
WAD001882984
3400 TAYLOR WAY
TACOMA WA 98421

CERTIFICATE OF DISPOSAL

Chemical Waste Management of the Northwest, Inc., ORD089452353, has received the following waste material:

GENERATOR:	PORT OF TACOMA
MANIFEST #:	011886698JJK
CWM TRACKING ID:	42938001
PROFILE #:	OR321468
LINE ITEM:	9b.1
QUANTITY:	1 DT
RECEIVED DATE:	10/15/13
DISPOSAL PROCESS(ES):	LANDFILL
FINAL DISPOSAL LOCATION:	LANDFILL 13
DISPOSAL DATE:	10/15/13

I certify, on behalf of the above listed treatment facility, that to the best of my knowledge, the above-described waste material was managed in compliance with all applicable laws, regulations, permits and licenses on the date listed above.

Bobbi Johnson

CWMNW RECORDS DEPARTMENT

Date: 10/21/13



CHEMICAL WASTE MANAGEMENT OF THE NW

17629 Cedar Springs Lane
Arlington, OR 97812
541 454 2643

PORT OF TACOMA
WAD001882984
3400 TAYLOR WAY
TACOMA WA 98421

CERTIFICATE OF DISPOSAL

Chemical Waste Management of the Northwest, Inc., ORD089452353, has received the following waste material:

GENERATOR:	PORT OF TACOMA
MANIFEST #:	011886699JJK
CWM TRACKING ID:	42938101
PROFILE #:	OR321468
LINE ITEM:	9b.1
QUANTITY:	1 DT
RECEIVED DATE:	10/15/13
DISPOSAL PROCESS(ES):	LANDFILL
FINAL DISPOSAL LOCATION:	LANDFILL 13
DISPOSAL DATE:	10/15/13

I certify, on behalf of the above listed treatment facility, that to the best of my knowledge, the above-described waste material was managed in compliance with all applicable laws, regulations, permits and licenses on the date listed above.

Bobbi Johnson

CWMNW RECORDS DEPARTMENT

Date: 10/21/13



CHEMICAL WASTE MANAGEMENT OF THE NW

17629 Cedar Springs Lane
Arlington, OR 97812
541 454 2643

PORT OF TACOMA
WAD001882984
3400 TAYLOR WAY
TACOMA WA 98421

CERTIFICATE OF DISPOSAL

Chemical Waste Management of the Northwest, Inc., ORD089452353, has received the following waste material:

GENERATOR:	PORT OF TACOMA
MANIFEST #:	011886697JJK
CWM TRACKING ID:	42938301
PROFILE #:	OR321468
LINE ITEM:	9b.1
QUANTITY:	1 DT
RECEIVED DATE:	10/15/13
DISPOSAL PROCESS(ES):	LANDFILL
FINAL DISPOSAL LOCATION:	LANDFILL 13
DISPOSAL DATE:	10/15/13

I certify, on behalf of the above listed treatment facility, that to the best of my knowledge, the above-described waste material was managed in compliance with all applicable laws, regulations, permits and licenses on the date listed above.

Bobbi J. Galvin

CWMNW RECORDS DEPARTMENT

Date: 10/21/13



CHEMICAL WASTE MANAGEMENT OF THE NW

17629 Cedar Springs Lane
Arlington, OR 97812
541 454 2643

PORT OF TACOMA
WAD001882984
3400 TAYLOR WAY
TACOMA WA 98421

CERTIFICATE OF DISPOSAL

Chemical Waste Management of the Northwest, Inc., ORD089452353, has received the following waste material:

GENERATOR:	PORT OF TACOMA
MANIFEST #:	011886696JJK
CWM TRACKING ID:	42938601
PROFILE #:	OR321468
LINE ITEM:	9b.1
QUANTITY:	1 DT
RECEIVED DATE:	10/15/13
DISPOSAL PROCESS(ES):	LANDFILL
FINAL DISPOSAL LOCATION:	LANDFILL 13
DISPOSAL DATE:	10/15/13

I certify, on behalf of the above listed treatment facility, that to the best of my knowledge, the above-described waste material was managed in compliance with all applicable laws, regulations, permits and licenses on the date listed above.

Bobbi Jo Graham

CWMNW RECORDS DEPARTMENT

Date: 10/21/13



CHEMICAL WASTE MANAGEMENT OF THE NW

17629 Cedar Springs Lane
Arlington, OR 97812
541 454 2643

PORT OF TACOMA
WAD001882984
3400 TAYLOR WAY
TACOMA WA 98421

CERTIFICATE OF DISPOSAL

Chemical Waste Management of the Northwest, Inc., ORD089452353, has received the following waste material:

GENERATOR:	PORT OF TACOMA
MANIFEST #:	011886693JJK
CWM TRACKING ID:	42938701
PROFILE #:	OR321468
LINE ITEM:	9b.1
QUANTITY:	1 DT
RECEIVED DATE:	10/15/13
DISPOSAL PROCESS(ES):	LANDFILL
FINAL DISPOSAL LOCATION:	LANDFILL 13
DISPOSAL DATE:	10/15/13

I certify, on behalf of the above listed treatment facility, that to the best of my knowledge, the above-described waste material was managed in compliance with all applicable laws, regulations, permits and licenses on the date listed above.

Robbin Franklin

CWMNW RECORDS DEPARTMENT

Date: 10/21/13



CHEMICAL WASTE MANAGEMENT OF THE NW

17629 Cedar Springs Lane
Arlington, OR 97812
541 454 2643

PORT OF TACOMA
WAD001882984
3400 TAYLOR WAY
TACOMA WA 98421

CERTIFICATE OF DISPOSAL

Chemical Waste Management of the Northwest, Inc., ORD089452353, has received the following waste material:

GENERATOR:	PORT OF TACOMA
MANIFEST #:	011886695JJK
CWM TRACKING ID:	42938901
PROFILE #:	OR321468
LINE ITEM:	9b.1
QUANTITY:	1 DT
RECEIVED DATE:	10/15/13
DISPOSAL PROCESS(ES):	LANDFILL
FINAL DISPOSAL LOCATION:	LANDFILL 13
DISPOSAL DATE:	10/15/13

I certify, on behalf of the above listed treatment facility, that to the best of my knowledge, the above-described waste material was managed in compliance with all applicable laws, regulations, permits and licenses on the date listed above.

Bobbi Jo Salmon

CWMNW RECORDS DEPARTMENT

Date: 10/21/13



CHEMICAL WASTE MANAGEMENT OF THE NW

17629 Cedar Springs Lane
Arlington, OR 97812
541 454 2643

PORT OF TACOMA
WAD001882984
3400 TAYLOR WAY
TACOMA WA 98421

CERTIFICATE OF DISPOSAL

Chemical Waste Management of the Northwest, Inc., ORD089452353, has received the following waste material:

GENERATOR:	PORT OF TACOMA
MANIFEST #:	011886694JJK
CWM TRACKING ID:	42939201
PROFILE #:	OR321468
LINE ITEM:	9b.1
QUANTITY:	1 DT
RECEIVED DATE:	10/15/13
DISPOSAL PROCESS(ES):	LANDFILL
FINAL DISPOSAL LOCATION:	LANDFILL 13
DISPOSAL DATE:	10/15/13

I certify, on behalf of the above listed treatment facility, that to the best of my knowledge, the above-described waste material was managed in compliance with all applicable laws, regulations, permits and licenses on the date listed above.

Bobbi Johnson

CWMNW RECORDS DEPARTMENT

Date: 10/21/13



CHEMICAL WASTE MANAGEMENT OF THE NW

17629 Cedar Springs Lane
Arlington, OR 97812
541 454 2643

PORT OF TACOMA
WAD001882984
3400 TAYLOR WAY
TACOMA WA 98421

CERTIFICATE OF DISPOSAL

Chemical Waste Management of the Northwest, Inc., ORD089452353, has received the following waste material:

GENERATOR:	PORT OF TACOMA
MANIFEST #:	011886677JJK
CWM TRACKING ID:	42939501
PROFILE #:	OR321468
LINE ITEM:	9b.1
QUANTITY:	1 DT
RECEIVED DATE:	10/15/13
DISPOSAL PROCESS(ES):	LANDFILL
FINAL DISPOSAL LOCATION:	LANDFILL 13
DISPOSAL DATE:	10/15/13

I certify, on behalf of the above listed treatment facility, that to the best of my knowledge, the above-described waste material was managed in compliance with all applicable laws, regulations, permits and licenses on the date listed above.

Bobbi Jo Galvin

CWMNW RECORDS DEPARTMENT

Date: 10/21/13



CHEMICAL WASTE MANAGEMENT OF THE NW

17629 Cedar Springs Lane
Arlington, OR 97812
541 454 2643

PORT OF TACOMA
WAD001882984
3400 TAYLOR WAY
TACOMA WA 98421

CERTIFICATE OF DISPOSAL

Chemical Waste Management of the Northwest, Inc., ORD089452353, has received the following waste material:

GENERATOR:	PORT OF TACOMA
MANIFEST #:	011886676JJK
CWM TRACKING ID:	42939601
PROFILE #:	OR321468
LINE ITEM:	9b.1
QUANTITY:	1 DT
RECEIVED DATE:	10/15/13
DISPOSAL PROCESS(ES):	LANDFILL
FINAL DISPOSAL LOCATION:	LANDFILL 13
DISPOSAL DATE:	10/15/13

I certify, on behalf of the above listed treatment facility, that to the best of my knowledge, the above-described waste material was managed in compliance with all applicable laws, regulations, permits and licenses on the date listed above.



CWMNW RECORDS DEPARTMENT

Date: 10/21/13





CHEMICAL WASTE MANAGEMENT OF THE NW

17629 Cedar Springs Lane
Arlington, OR 97812
541 454 2643

PORT OF TACOMA
WAD001882984
3400 TAYLOR WAY
TACOMA WA 98421

CERTIFICATE OF DISPOSAL

Chemical Waste Management of the Northwest, Inc., ORD089452353, has received the following waste material:

GENERATOR: PORT OF TACOMA
MANIFEST #: 011886673JJK
CWM TRACKING ID: 42939901
PROFILE #: OR321468
LINE ITEM: 9b.1
QUANTITY: 1 DT
RECEIVED DATE: 10/15/13

DISPOSAL PROCESS(ES): LANDFILL
FINAL DISPOSAL LOCATION: LANDFILL 13
DISPOSAL DATE: 10/15/13

I certify, on behalf of the above listed treatment facility, that to the best of my knowledge, the above-described waste material was managed in compliance with all applicable laws, regulations, permits and licenses on the date listed above.

CWMNW RECORDS DEPARTMENT

Date: 10/21/13





CHEMICAL WASTE MANAGEMENT OF THE NW

17629 Cedar Springs Lane
Arlington, OR 97812
541 454 2643

PORT OF TACOMA
WAD001882984
3400 TAYLOR WAY
TACOMA WA 98421

CERTIFICATE OF DISPOSAL

Chemical Waste Management of the Northwest, Inc., ORD089452353, has received the following waste material:

GENERATOR:	PORT OF TACOMA
MANIFEST #:	011886675JJK
CWM TRACKING ID:	42940001
PROFILE #:	OR321468
LINE ITEM:	9b.1
QUANTITY:	1 DI
RECEIVED DATE:	10/15/13
DISPOSAL PROCESS(ES):	LANDFILL
FINAL DISPOSAL LOCATION:	LANDFILL 13
DISPOSAL DATE:	10/15/13

I certify, on behalf of the above listed treatment facility, that to the best of my knowledge, the above-described waste material was managed in compliance with all applicable laws, regulations, permits and licenses on the date listed above.

Bobbi G. Fralson

CWMNW RECORDS DEPARTMENT

Date: 10/21/13





CHEMICAL WASTE MANAGEMENT OF THE NW

17629 Cedar Springs Lane
Arlington, OR 97812
541 454 2643

PORT OF TACOMA
WAD001882984
3400 TAYLOR WAY
TACOMA WA 98421

CERTIFICATE OF DISPOSAL

Chemical Waste Management of the Northwest, Inc., ORD089452353, has received the following waste material:

GENERATOR:	PORT OF TACOMA
MANIFEST #:	011886674JJK
CWM TRACKING ID:	42940101
PROFILE #:	OR321468
LINE ITEM:	9b.1
QUANTITY:	1 DT
RECEIVED DATE:	10/15/13
DISPOSAL PROCESS(ES):	LANDFILL
FINAL DISPOSAL LOCATION:	LANDFILL 13
DISPOSAL DATE:	10/15/13

I certify, on behalf of the above listed treatment facility, that to the best of my knowledge, the above-described waste material was managed in compliance with all applicable laws, regulations, permits and licenses on the date listed above.

CWMNW RECORDS DEPARTMENT

Date: 10/21/13



CHEMICAL WASTE MANAGEMENT OF THE NW

17629 Cedar Springs Lane
Arlington, OR 97812
541 454 2643

PORT OF TACOMA
WAD001882984
3400 TAYLOR WAY
TACOMA WA 98421

CERTIFICATE OF DISPOSAL

Chemical Waste Management of the Northwest, Inc., ORD089452353, has received the following waste material:

GENERATOR:	PORT OF TACOMA
MANIFEST #:	011886667JJK
CWM TRACKING ID:	42940401
PROFILE #:	OR321468
LINE ITEM:	9b.1
QUANTITY:	1 DT
RECEIVED DATE:	10/15/13
DISPOSAL PROCESS(ES):	LANDFILL
FINAL DISPOSAL LOCATION:	LANDFILL 13
DISPOSAL DATE:	10/15/13

I certify, on behalf of the above listed treatment facility, that to the best of my knowledge, the above-described waste material was managed in compliance with all applicable laws, regulations, permits and licenses on the date listed above.

Robbie Franklin

CWMNW RECORDS DEPARTMENT

Date: 10/21/13



CHEMICAL WASTE MANAGEMENT OF THE NW

17629 Cedar Springs Lane
Arlington, OR 97812
541 454 2643

PORT OF TACOMA
WAD001882984
3400 TAYLOR WAY
TACOMA WA 98421

CERTIFICATE OF DISPOSAL

Chemical Waste Management of the Northwest, Inc., ORD089452353, has received the following waste material:

GENERATOR:	PORT OF TACOMA
MANIFEST #:	011886669JJK
CWM TRACKING ID:	42940801
PROFILE #:	OR321468
LINE ITEM:	9b.1 ₁
QUANTITY:	1 DT
RECEIVED DATE:	10/15/13
DISPOSAL PROCESS(ES):	LANDFILL
FINAL DISPOSAL LOCATION:	LANDFILL 13
DISPOSAL DATE:	10/15/13

I certify, on behalf of the above listed treatment facility, that to the best of my knowledge, the above-described waste material was managed in compliance with all applicable laws, regulations, permits and licenses on the date listed above.

Bobbi Johnson

CWMNW RECORDS DEPARTMENT

Date: 10/21/13



CHEMICAL WASTE MANAGEMENT OF THE NW

17629 Cedar Springs Lane
Arlington, OR 97812
541 454 2643

PORT OF TACOMA
WAD001882984
3400 TAYLOR WAY
TACOMA WA 98421

CERTIFICATE OF DISPOSAL

Chemical Waste Management of the Northwest, Inc., ORD089452353, has received the following waste material:

GENERATOR:	PORT OF TACOMA
MANIFEST #:	011886666JJK
CWM TRACKING ID:	42940901
PROFILE #:	OR321468
LINE ITEM:	9b.1
QUANTITY:	1 DT
RECEIVED DATE:	10/15/13
DISPOSAL PROCESS(ES):	LANDFILL
FINAL DISPOSAL LOCATION:	LANDFILL 13
DISPOSAL DATE:	10/15/13

I certify, on behalf of the above listed treatment facility, that to the best of my knowledge, the above-described waste material was managed in compliance with all applicable laws, regulations, permits and licenses on the date listed above.

Bobbi J Galvin

CWMNW RECORDS DEPARTMENT

Date: 10/21/13



CHEMICAL WASTE MANAGEMENT OF THE NW

17629 Cedar Springs Lane
Arlington, OR 97812
(541) 454-2643
(541) 454-3279 Fax

PORT OF TACOMA
WAD001882984
3400 TAYLOR WAY
TACOMA WA 98421

CERTIFICATE OF DISPOSAL

Chemical Waste Management of the Northwest, Inc., ORD089452353, has received the following waste material:

GENERATOR:	PORT OF TACOMA
MANIFEST #:	011886661JJK
CWM TRACKING ID:	429463-01
PROFILE #:	OR321468
LINE ITEM:	9b.1
QUANTITY:	1 DT
RECEIVED DATE:	10/16/13
DISPOSAL PROCESS(ES):	LANDFILL
FINAL DISPOSAL LOCATION:	LANDFILL 13
DISPOSAL DATE:	10/16/13

I certify, on behalf of the above listed treatment facility, that to the best of my knowledge, the above-described waste material was managed in compliance with all applicable laws, regulations, permits and licenses on the date listed above.



CWMNW RECORDS DEPARTMENT
Date: 10/22/13



CHEMICAL WASTE MANAGEMENT OF THE NW

17629 Cedar Springs Lane
Arlington, OR 97812
(541) 454-2643
(541) 454-3279 Fax

PORT OF TACOMA
WAD001882984
3400 TAYLOR WAY
TACOMA WA 98421

CERTIFICATE OF DISPOSAL

Chemical Waste Management of the Northwest, Inc., ORD089452353, has received the following waste material:

GENERATOR:	PORT OF TACOMA
MANIFEST #:	011886663JJK
CWM TRACKING ID:	429464-01
PROFILE #:	OR321468
LINE ITEM:	9b.1
QUANTITY:	1 DT
RECEIVED DATE:	10/16/13
DISPOSAL PROCESS(ES):	LANDFILL
FINAL DISPOSAL LOCATION:	LANDFILL 13
DISPOSAL DATE:	10/16/13

I certify, on behalf of the above listed treatment facility, that to the best of my knowledge, the above-described waste material was managed in compliance with all applicable laws, regulations, permits and licenses on the date listed above.



CWMNW RECORDS DEPARTMENT

Date: 10/22/13



CHEMICAL WASTE MANAGEMENT OF THE NW

17629 Cedar Springs Lane
Arlington, OR 97812
(541) 454-2643
(541) 454-3279 Fax

PORT OF TACOMA
WAD001882984
3400 TAYLOR WAY
TACOMA WA 98421

CERTIFICATE OF DISPOSAL

Chemical Waste Management of the Northwest, Inc., ORD089452353, has received the following waste material:

GENERATOR:	PORT OF TACOMA
MANIFEST #:	011886665JJK
CWM TRACKING ID:	429470-01
PROFILE #:	OR321468
LINE ITEM:	9b.1
QUANTITY:	1 DT
RECEIVED DATE:	10/16/13
DISPOSAL PROCESS(ES):	LANDFILL
FINAL DISPOSAL LOCATION:	LANDFILL 13
DISPOSAL DATE:	10/16/13

I certify, on behalf of the above listed treatment facility, that to the best of my knowledge, the above-described waste material was managed in compliance with all applicable laws, regulations, permits and licenses on the date listed above.

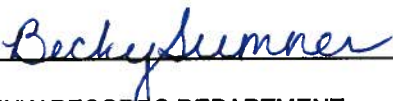

CWMNW RECORDS DEPARTMENT

Date: 10/22/13



CHEMICAL WASTE MANAGEMENT OF THE NW

17629 Cedar Springs Lane
Arlington, OR 97812
(541) 454-2643
(541) 454-3279 Fax

PORT OF TACOMA
WAD001882984
3400 TAYLOR WAY
TACOMA WA 98421

CERTIFICATE OF DISPOSAL

Chemical Waste Management of the Northwest, Inc., ORD089452353, has received the following waste material:

GENERATOR:	PORT OF TACOMA
MANIFEST #:	011886664JJK
CWM TRACKING ID:	429471-01
PROFILE #:	OR321468
LINE ITEM:	9b.1
QUANTITY:	1 DT
RECEIVED DATE:	10/16/13
DISPOSAL PROCESS(ES):	LANDFILL
FINAL DISPOSAL LOCATION:	LANDFILL 13
DISPOSAL DATE:	10/16/13

I certify, on behalf of the above listed treatment facility, that to the best of my knowledge, the above-described waste material was managed in compliance with all applicable laws, regulations, permits and licenses on the date listed above.

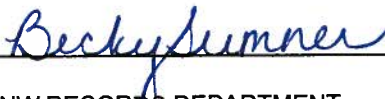

CWMNW RECORDS DEPARTMENT

Date: 10/22/13



CHEMICAL WASTE MANAGEMENT OF THE NW

17629 Cedar Springs Lane
Arlington, OR 97812
(541) 454-2643
(541) 454-3279 Fax

PORT OF TACOMA
WAD001882984
3400 TAYLOR WAY
TACOMA WA 98421

CERTIFICATE OF DISPOSAL

Chemical Waste Management of the Northwest, Inc., ORD089452353, has received the following waste material:

GENERATOR: PORT OF TACOMA
MANIFEST #: 011886671JJK
CWM TRACKING ID: 429478-01
PROFILE #: OR321468
LINE ITEM: 9b.1
QUANTITY: 1 DT
RECEIVED DATE: 10/16/13

DISPOSAL PROCESS(ES): LANDFILL
FINAL DISPOSAL LOCATION: LANDFILL 13
DISPOSAL DATE: 10/16/13

I certify, on behalf of the above listed treatment facility, that to the best of my knowledge, the above-described waste material was managed in compliance with all applicable laws, regulations, permits and licenses on the date listed above.

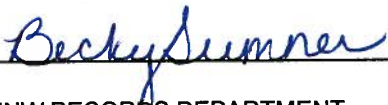

CWMNW RECORDS DEPARTMENT

Date: 10/22/13



CHEMICAL WASTE MANAGEMENT OF THE NW

17629 Cedar Springs Lane
Arlington, OR 97812
(541) 454-2643
(541) 454-3279 Fax

PORT OF TACOMA
WAD001882984
3400 TAYLOR WAY
TACOMA WA 98421

CERTIFICATE OF DISPOSAL

Chemical Waste Management of the Northwest, Inc., ORD089452353, has received the following waste material:

GENERATOR:	PORT OF TACOMA
MANIFEST #:	011886655JJK
CWM TRACKING ID:	429480-01
PROFILE #:	OR321468
LINE ITEM:	9b.1
QUANTITY:	1 DT
RECEIVED DATE:	10/16/13
DISPOSAL PROCESS(ES):	LANDFILL
FINAL DISPOSAL LOCATION:	LANDFILL 13
DISPOSAL DATE:	10/16/13

I certify, on behalf of the above listed treatment facility, that to the best of my knowledge, the above-described waste material was managed in compliance with all applicable laws, regulations, permits and licenses on the date listed above.

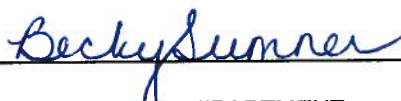

CWMNW RECORDS DEPARTMENT

Date: 10/22/13



CHEMICAL WASTE MANAGEMENT OF THE NW

17629 Cedar Springs Lane
Arlington, OR 97812
(541) 454-2643
(541) 454-3279 Fax

PORT OF TACOMA
WAD001882984
3400 TAYLOR WAY
TACOMA WA 98421

CERTIFICATE OF DISPOSAL

Chemical Waste Management of the Northwest, Inc., ORD089452353, has received the following waste material:

GENERATOR:	PORT OF TACOMA
MANIFEST #:	011886660JJK
CWM TRACKING ID:	429481-01
PROFILE #:	OR321468
LINE ITEM:	9b.1
QUANTITY:	1 DT
RECEIVED DATE:	10/16/13
DISPOSAL PROCESS(ES):	LANDFILL
FINAL DISPOSAL LOCATION:	LANDFILL 13
DISPOSAL DATE:	10/16/13

I certify, on behalf of the above listed treatment facility, that to the best of my knowledge, the above-described waste material was managed in compliance with all applicable laws, regulations, permits and licenses on the date listed above.



CWMNW RECORDS DEPARTMENT

Date: 10/22/13



CHEMICAL WASTE MANAGEMENT OF THE NW

17629 Cedar Springs Lane
Arlington, OR 97812
(541) 454-2643
(541) 454-3279 Fax

PORT OF TACOMA
WAD001882984
3400 TAYLOR WAY
TACOMA WA 98421

CERTIFICATE OF DISPOSAL

Chemical Waste Management of the Northwest, Inc., ORD089452353, has received the following waste material:

GENERATOR:	PORT OF TACOMA
MANIFEST #:	011886672JJK
CWM TRACKING ID:	429485-01
PROFILE #:	OR321468
LINE ITEM:	9b.1
QUANTITY:	1 DT
RECEIVED DATE:	10/16/13
DISPOSAL PROCESS(ES):	LANDFILL
FINAL DISPOSAL LOCATION:	LANDFILL 13
DISPOSAL DATE:	10/16/13

I certify, on behalf of the above listed treatment facility, that to the best of my knowledge, the above-described waste material was managed in compliance with all applicable laws, regulations, permits and licenses on the date listed above.

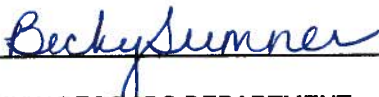

CWMNW RECORDS DEPARTMENT

Date: 10/22/13



CHEMICAL WASTE MANAGEMENT OF THE NW

17629 Cedar Springs Lane
Arlington, OR 97812
(541) 454-2643
(541) 454-3279 Fax

PORT OF TACOMA
WAD001882984
3400 TAYLOR WAY
TACOMA WA 98421

CERTIFICATE OF DISPOSAL

Chemical Waste Management of the Northwest, Inc., ORD089452353, has received the following waste material:

GENERATOR:	PORT OF TACOMA
MANIFEST #:	011886658JJK
CWM TRACKING ID:	429486-01
PROFILE #:	OR321468
LINE ITEM:	9b.1
QUANTITY:	1 DT
RECEIVED DATE:	10/16/13
DISPOSAL PROCESS(ES):	LANDFILL
FINAL DISPOSAL LOCATION:	LANDFILL 13
DISPOSAL DATE:	10/16/13

I certify, on behalf of the above listed treatment facility, that to the best of my knowledge, the above-described waste material was managed in compliance with all applicable laws, regulations, permits and licenses on the date listed above.

Becky Sumner

CWMNW RECORDS DEPARTMENT

Date: 10/22/13



CHEMICAL WASTE MANAGEMENT OF THE NW

17629 Cedar Springs Lane
Arlington, OR 97812
(541) 454-2643
(541) 454-3279 Fax

PORT OF TACOMA
WAD001882984
3400 TAYLOR WAY
TACOMA WA 98421

CERTIFICATE OF DISPOSAL

Chemical Waste Management of the Northwest, Inc., ORD089452353, has received the following waste material:

GENERATOR:	PORT OF TACOMA
MANIFEST #:	011886659JJK
CWM TRACKING ID:	429487-01
PROFILE #:	OR321468
LINE ITEM:	9b.1
QUANTITY:	1 DT
RECEIVED DATE:	10/16/13
DISPOSAL PROCESS(ES):	LANDFILL
FINAL DISPOSAL LOCATION:	LANDFILL 13
DISPOSAL DATE:	10/16/13

I certify, on behalf of the above listed treatment facility, that to the best of my knowledge, the above-described waste material was managed in compliance with all applicable laws, regulations, permits and licenses on the date listed above.



CWMNW RECORDS DEPARTMENT
Date: 10/22/13



CHEMICAL WASTE MANAGEMENT OF THE NW

17629 Cedar Springs Lane
Arlington, OR 97812
(541) 454-2643
(541) 454-3279 Fax

PORT OF TACOMA
WAD001882984
3400 TAYLOR WAY
TACOMA WA 98421

CERTIFICATE OF DISPOSAL

Chemical Waste Management of the Northwest, Inc., ORD089452353, has received the following waste material:

GENERATOR:	PORT OF TACOMA
MANIFEST #:	011886657JJK
CWM TRACKING ID:	429488-01
PROFILE #:	OR321468
LINE ITEM:	9b.1
QUANTITY:	1 DT
RECEIVED DATE:	10/16/13
DISPOSAL PROCESS(ES):	LANDFILL
FINAL DISPOSAL LOCATION:	LANDFILL 13
DISPOSAL DATE:	10/16/13

I certify, on behalf of the above listed treatment facility, that to the best of my knowledge, the above-described waste material was managed in compliance with all applicable laws, regulations, permits and licenses on the date listed above.



CWMNW RECORDS DEPARTMENT

Date: 10/22/13



CHEMICAL WASTE MANAGEMENT OF THE NW

17629 Cedar Springs Lane
Arlington, OR 97812
(541) 454-2643
(541) 454-3279 Fax

PORT OF TACOMA
WAD001882984
3400 TAYLOR WAY
TACOMA WA 98421

CERTIFICATE OF DISPOSAL

Chemical Waste Management of the Northwest, Inc., ORD089452353, has received the following waste material:

GENERATOR:	PORT OF TACOMA
MANIFEST #:	011886656JJK
CWM TRACKING ID:	429489-01
PROFILE #:	OR321468
LINE ITEM:	9b.1
QUANTITY:	1 DT
RECEIVED DATE:	10/16/13
DISPOSAL PROCESS(ES):	LANDFILL
FINAL DISPOSAL LOCATION:	LANDFILL 13
DISPOSAL DATE:	10/16/13

I certify, on behalf of the above listed treatment facility, that to the best of my knowledge, the above-described waste material was managed in compliance with all applicable laws, regulations, permits and licenses on the date listed above.

Becky Sumner

CWMNW RECORDS DEPARTMENT

Date: 10/22/13



CHEMICAL WASTE MANAGEMENT OF THE NW

17629 Cedar Springs Lane
Arlington, OR 97812
(541) 454-2643
(541) 454-3279 Fax

PORT OF TACOMA
WAD001882984
3400 TAYLOR WAY
TACOMA WA 98421

CERTIFICATE OF DISPOSAL

Chemical Waste Management of the Northwest, Inc., ORD089452353, has received the following waste material:

GENERATOR:	PORT OF TACOMA
MANIFEST #:	011886653JJK
CWM TRACKING ID:	429491-01
PROFILE #:	OR321468
LINE ITEM:	9b.1
QUANTITY:	1 DT
RECEIVED DATE:	10/16/13
DISPOSAL PROCESS(ES):	LANDFILL
FINAL DISPOSAL LOCATION:	LANDFILL 13
DISPOSAL DATE:	10/16/13

I certify, on behalf of the above listed treatment facility, that to the best of my knowledge, the above-described waste material was managed in compliance with all applicable laws, regulations, permits and licenses on the date listed above.

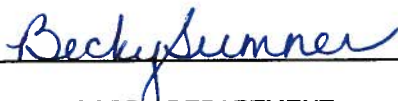

CWMNW RECORDS DEPARTMENT

Date: 10/22/13



CHEMICAL WASTE MANAGEMENT OF THE NW

17629 Cedar Springs Lane
Arlington, OR 97812
(541) 454-2643
(541) 454-3279 Fax

PORT OF TACOMA
WAD001882984
3400 TAYLOR WAY
TACOMA WA 98421

CERTIFICATE OF DISPOSAL

Chemical Waste Management of the Northwest, Inc., ORD089452353, has received the following waste material:

GENERATOR:	PORT OF TACOMA
MANIFEST #:	011886654JJK
CWM TRACKING ID:	429492-01
PROFILE #:	OR321468
LINE ITEM:	9b.1
QUANTITY:	1 DT
RECEIVED DATE:	10/16/13
DISPOSAL PROCESS(ES):	LANDFILL
FINAL DISPOSAL LOCATION:	LANDFILL 13
DISPOSAL DATE:	10/16/13

I certify, on behalf of the above listed treatment facility, that to the best of my knowledge, the above-described waste material was managed in compliance with all applicable laws, regulations, permits and licenses on the date listed above.



CWMNW RECORDS DEPARTMENT

Date: 10/22/13



CHEMICAL WASTE MANAGEMENT OF THE NW

17629 Cedar Springs Lane
Arlington, OR 97812
(541) 454-2643
(541) 454-3279 Fax

PORT OF TACOMA
WAD001882984
3400 TAYLOR WAY
TACOMA WA 98421

CERTIFICATE OF DISPOSAL

Chemical Waste Management of the Northwest, Inc., ORD089452353, has received the following waste material:

GENERATOR:	PORT OF TACOMA
MANIFEST #:	011886668JJK
CWM TRACKING ID:	429475-01
PROFILE #:	OR321468
LINE ITEM:	9b.1
QUANTITY:	1 DT
RECEIVED DATE:	10/16/13
DISPOSAL PROCESS(ES):	LANDFILL
FINAL DISPOSAL LOCATION:	LANDFILL 13
DISPOSAL DATE:	10/16/13

I certify, on behalf of the above listed treatment facility, that to the best of my knowledge, the above-described waste material was managed in compliance with all applicable laws, regulations, permits and licenses on the date listed above.

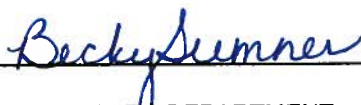

CWMNW RECORDS DEPARTMENT

Date: 10/22/13



CHEMICAL WASTE MANAGEMENT OF THE NW

17629 Cedar Springs Lane
Arlington, OR 97812
(541) 454-2643
(541) 454-3279 Fax

PORT OF TACOMA
WAD001882984
3400 TAYLOR WAY
TACOMA WA 98421

CERTIFICATE OF DISPOSAL

Chemical Waste Management of the Northwest, Inc., ORD089452353, has received the following waste material:

GENERATOR:	PORT OF TACOMA
MANIFEST #:	011886662JJK
CWM TRACKING ID:	429462-01
PROFILE #:	OR321468
LINE ITEM:	9b.1
QUANTITY:	1 DT
RECEIVED DATE:	10/16/13
DISPOSAL PROCESS(ES):	LANDFILL
FINAL DISPOSAL LOCATION:	LANDFILL 13
DISPOSAL DATE:	10/16/13

I certify, on behalf of the above listed treatment facility, that to the best of my knowledge, the above-described waste material was managed in compliance with all applicable laws, regulations, permits and licenses on the date listed above.



CWMNW RECORDS DEPARTMENT

Date: 10/22/13



WASTE MANAGEMENT
17629 Cedar Springs Lane
Arlington, OR 97812

PORT OF TACOMA
WAD001882984
3400 TAYLOR WAY
TACOMA WA 98421

CERTIFICATE OF DISPOSAL

Chemical Waste Management of the Northwest, Inc., ORD089452353, has received the following waste material:

GENERATOR:	PORT OF TACOMA
MANIFEST #:	011886635JJK
CWM TRACKING ID:	429546-01
PROFILE #:	OR321468
LINE ITEM:	9b.1
QUANTITY:	1 DT
RECEIVED DATE:	10/17/13
DISPOSAL PROCESS(ES):	LANDFILL
FINAL DISPOSAL LOCATION:	LANDFILL 13
DISPOSAL DATE:	10/17/13

I certify, on behalf of the above listed treatment facility, that to the best of my knowledge, the above-described waste material was managed in compliance with all applicable laws, regulations, permits and licenses on the date listed above.

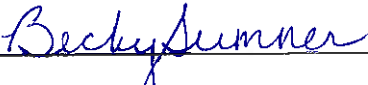

CWMNW RECORDS DEPARTMENT

Date: 10/25/13



WASTE MANAGEMENT
17629 Cedar Springs Lane
Arlington, OR 97812

PORT OF TACOMA
WAD001882984
3400 TAYLOR WAY
TACOMA WA 98421

CERTIFICATE OF DISPOSAL

Chemical Waste Management of the Northwest, Inc., ORD089452353, has received the following waste material:

GENERATOR:	PORT OF TACOMA
MANIFEST #:	011886634JJK
CWM TRACKING ID:	429549-01
PROFILE #:	OR321468
LINE ITEM:	9b.1
QUANTITY:	1 DT
RECEIVED DATE:	10/17/13
DISPOSAL PROCESS(ES):	LANDFILL
FINAL DISPOSAL LOCATION:	LANDFILL 13
DISPOSAL DATE:	10/17/13

I certify, on behalf of the above listed treatment facility, that to the best of my knowledge, the above-described waste material was managed in compliance with all applicable laws, regulations, permits and licenses on the date listed above.



CWMNW RECORDS DEPARTMENT

Date: 10/25/13



CHEMICAL WASTE MANAGEMENT OF THE NW

17629 Cedar Springs Lane
Arlington, OR 97812
(541) 454-2643
(541) 454-3279 Fax

PORT OF TACOMA
WAD001882984
3400 TAYLOR WAY
TACOMA WA 98421

CERTIFICATE OF DISPOSAL

Chemical Waste Management of the Northwest, Inc., ORD089452353, has received the following waste material:

GENERATOR:	PORT OF TACOMA
MANIFEST #:	011886648JJK
CWM TRACKING ID:	429532-01
PROFILE #:	OR321468
LINE ITEM:	9b.1
QUANTITY:	1 DT
RECEIVED DATE:	10/17/13
DISPOSAL PROCESS(ES):	LANDFILL
FINAL DISPOSAL LOCATION:	LANDFILL 13
DISPOSAL DATE:	10/17/13

I certify, on behalf of the above listed treatment facility, that to the best of my knowledge, the above-described waste material was managed in compliance with all applicable laws, regulations, permits and licenses on the date listed above.



CWMNW RECORDS DEPARTMENT

Date: 10/22/13



CHEMICAL WASTE MANAGEMENT OF THE NW

17629 Cedar Springs Lane
Arlington, OR 97812
(541) 454-2643
(541) 454-3279 Fax

PORT OF TACOMA
WAD001882984
3400 TAYLOR WAY
TACOMA WA 98421

CERTIFICATE OF DISPOSAL

Chemical Waste Management of the Northwest, Inc., ORD089452353, has received the following waste material:

GENERATOR:	PORT OF TACOMA
MANIFEST #:	011886644JJK
CWM TRACKING ID:	429534-01
PROFILE #:	OR321468
LINE ITEM:	9b.1
QUANTITY:	1 DT
RECEIVED DATE:	10/17/13
DISPOSAL PROCESS(ES):	LANDFILL
FINAL DISPOSAL LOCATION:	LANDFILL 13
DISPOSAL DATE:	10/17/13

I certify, on behalf of the above listed treatment facility, that to the best of my knowledge, the above-described waste material was managed in compliance with all applicable laws, regulations, permits and licenses on the date listed above.

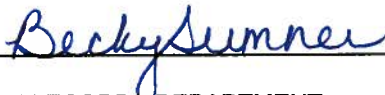

CWMNW RECORDS DEPARTMENT

Date: 10/22/13



CHEMICAL WASTE MANAGEMENT OF THE NW

17629 Cedar Springs Lane
Arlington, OR 97812
(541) 454-2643
(541) 454-3279 Fax

PORT OF TACOMA
WAD001882984
3400 TAYLOR WAY
TACOMA WA 98421

CERTIFICATE OF DISPOSAL

Chemical Waste Management of the Northwest, Inc., ORD089452353, has received the following waste material:

GENERATOR:	PORT OF TACOMA
MANIFEST #:	011886646JJK
CWM TRACKING ID:	429536-01
PROFILE #:	OR321468
LINE ITEM:	9b.1
QUANTITY:	1 DT
RECEIVED DATE:	10/17/13
DISPOSAL PROCESS(ES):	LANDFILL
FINAL DISPOSAL LOCATION:	LANDFILL 13
DISPOSAL DATE:	10/17/13

I certify, on behalf of the above listed treatment facility, that to the best of my knowledge, the above-described waste material was managed in compliance with all applicable laws, regulations, permits and licenses on the date listed above.



CWMNW RECORDS DEPARTMENT

Date: 10/22/13



CHEMICAL WASTE MANAGEMENT OF THE NW

17629 Cedar Springs Lane
Arlington, OR 97812
(541) 454-2643
(541) 454-3279 Fax

PORT OF TACOMA
WAD001882984
3400 TAYLOR WAY
TACOMA WA 98421

CERTIFICATE OF DISPOSAL

Chemical Waste Management of the Northwest, Inc., ORD089452353, has received the following waste material:

GENERATOR:	PORT OF TACOMA
MANIFEST #:	011886649JJK
CWM TRACKING ID:	429537-01
PROFILE #:	OR321468
LINE ITEM:	9b.1
QUANTITY:	1 DT
RECEIVED DATE:	10/17/13
DISPOSAL PROCESS(ES):	LANDFILL
FINAL DISPOSAL LOCATION:	LANDFILL 13
DISPOSAL DATE:	10/17/13

I certify, on behalf of the above listed treatment facility, that to the best of my knowledge, the above-described waste material was managed in compliance with all applicable laws, regulations, permits and licenses on the date listed above.



CWMNW RECORDS DEPARTMENT

Date: 10/22/13



CHEMICAL WASTE MANAGEMENT OF THE NW

17629 Cedar Springs Lane
Arlington, OR 97812
(541) 454-2643
(541) 454-3279 Fax

PORT OF TACOMA
WAD001882984
3400 TAYLOR WAY
TACOMA WA 98421

CERTIFICATE OF DISPOSAL

Chemical Waste Management of the Northwest, Inc., ORD089452353, has received the following waste material:

GENERATOR:	PORT OF TACOMA
MANIFEST #:	011886643JJK
CWM TRACKING ID:	429538-01
PROFILE #:	OR321468
LINE ITEM:	9b.1
QUANTITY:	1 DT
RECEIVED DATE:	10/17/13
DISPOSAL PROCESS(ES):	LANDFILL
FINAL DISPOSAL LOCATION:	LANDFILL 13
DISPOSAL DATE:	10/17/13

I certify, on behalf of the above listed treatment facility, that to the best of my knowledge, the above-described waste material was managed in compliance with all applicable laws, regulations, permits and licenses on the date listed above.



CWMNW RECORDS DEPARTMENT

Date: 10/22/13



CHEMICAL WASTE MANAGEMENT OF THE NW

17629 Cedar Springs Lane
Arlington, OR 97812
(541) 454-2643
(541) 454-3279 Fax

PORT OF TACOMA
WAD001882984
3400 TAYLOR WAY
TACOMA WA 98421

CERTIFICATE OF DISPOSAL

Chemical Waste Management of the Northwest, Inc., ORD089452353, has received the following waste material:

GENERATOR:	PORT OF TACOMA
MANIFEST #:	011886637JJK
CWM TRACKING ID:	429542-01
PROFILE #:	OR321468
LINE ITEM:	9b.1
QUANTITY:	1 DT
RECEIVED DATE:	10/17/13
DISPOSAL PROCESS(ES):	LANDFILL
FINAL DISPOSAL LOCATION:	LANDFILL 13
DISPOSAL DATE:	10/17/13

I certify, on behalf of the above listed treatment facility, that to the best of my knowledge, the above-described waste material was managed in compliance with all applicable laws, regulations, permits and licenses on the date listed above.



CWMNW RECORDS DEPARTMENT

Date: 10/22/13



CHEMICAL WASTE MANAGEMENT OF THE NW

17629 Cedar Springs Lane
Arlington, OR 97812
(541) 454-2643
(541) 454-3279 Fax

PORT OF TACOMA
WAD001882984
3400 TAYLOR WAY
TACOMA WA 98421

CERTIFICATE OF DISPOSAL

Chemical Waste Management of the Northwest, Inc., ORD089452353, has received the following waste material:

GENERATOR: PORT OF TACOMA
MANIFEST #: 011886636JJK
CWM TRACKING ID: 429543-01
PROFILE #: OR321468
LINE ITEM: 9b.1
QUANTITY: 1 DT
RECEIVED DATE: 10/17/13

DISPOSAL PROCESS(ES): LANDFILL
FINAL DISPOSAL LOCATION: LANDFILL 13
DISPOSAL DATE: 10/17/13

I certify, on behalf of the above listed treatment facility, that to the best of my knowledge, the above-described waste material was managed in compliance with all applicable laws, regulations, permits and licenses on the date listed above.



CWMNW RECORDS DEPARTMENT

Date: 10/22/13



CHEMICAL WASTE MANAGEMENT OF THE NW

17629 Cedar Springs Lane
Arlington, OR 97812
(541) 454-2643
(541) 454-3279 Fax

PORT OF TACOMA
WAD001882984
3400 TAYLOR WAY
TACOMA WA 98421

CERTIFICATE OF DISPOSAL

Chemical Waste Management of the Northwest, Inc., ORD089452353, has received the following waste material:

GENERATOR:	PORT OF TACOMA
MANIFEST #:	011886645JJK
CWM TRACKING ID:	429544-01
PROFILE #:	OR321468
LINE ITEM:	9b.1
QUANTITY:	1 DT
RECEIVED DATE:	10/17/13
DISPOSAL PROCESS(ES):	LANDFILL
FINAL DISPOSAL LOCATION:	LANDFILL 13
DISPOSAL DATE:	10/17/13

I certify, on behalf of the above listed treatment facility, that to the best of my knowledge, the above-described waste material was managed in compliance with all applicable laws, regulations, permits and licenses on the date listed above.

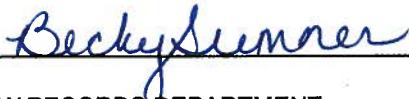

CWMNW RECORDS DEPARTMENT

Date: 10/22/13



CHEMICAL WASTE MANAGEMENT OF THE NW

17629 Cedar Springs Lane
Arlington, OR 97812
(541) 454-2643
(541) 454-3279 Fax

PORT OF TACOMA
WAD001882984
3400 TAYLOR WAY
TACOMA WA 98421

CERTIFICATE OF DISPOSAL

Chemical Waste Management of the Northwest, Inc., ORD089452353, has received the following waste material:

GENERATOR:	PORT OF TACOMA
MANIFEST #:	011886650JJK
CWM TRACKING ID:	429547-01
PROFILE #:	OR321468
LINE ITEM:	9b.1
QUANTITY:	1 DT
RECEIVED DATE:	10/17/13
DISPOSAL PROCESS(ES):	LANDFILL
FINAL DISPOSAL LOCATION:	LANDFILL 13
DISPOSAL DATE:	10/17/13

I certify, on behalf of the above listed treatment facility, that to the best of my knowledge, the above-described waste material was managed in compliance with all applicable laws, regulations, permits and licenses on the date listed above.

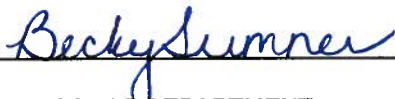

CWMNW RECORDS DEPARTMENT

Date: 10/22/13



CHEMICAL WASTE MANAGEMENT OF THE NW

17629 Cedar Springs Lane
Arlington, OR 97812
(541) 454-2643
(541) 454-3279 Fax

PORT OF TACOMA
WAD001882984
3400 TAYLOR WAY
TACOMA WA 98421

CERTIFICATE OF DISPOSAL

Chemical Waste Management of the Northwest, Inc., ORD089452353, has received the following waste material:

GENERATOR:	PORT OF TACOMA
MANIFEST #:	011886651JJK
CWM TRACKING ID:	429551-01
PROFILE #:	OR321468
LINE ITEM:	9b.1
QUANTITY:	1 DT
RECEIVED DATE:	10/17/13
DISPOSAL PROCESS(ES):	LANDFILL
FINAL DISPOSAL LOCATION:	LANDFILL 13
DISPOSAL DATE:	10/17/13

I certify, on behalf of the above listed treatment facility, that to the best of my knowledge, the above-described waste material was managed in compliance with all applicable laws, regulations, permits and licenses on the date listed above.

Becky Sumner

CWMNW RECORDS DEPARTMENT

Date: 10/22/13



CHEMICAL WASTE MANAGEMENT OF THE NW

17629 Cedar Springs Lane
Arlington, OR 97812
(541) 454-2643
(541) 454-3279 Fax

PORT OF TACOMA
WAD001882984
3400 TAYLOR WAY
TACOMA WA 98421

CERTIFICATE OF DISPOSAL

Chemical Waste Management of the Northwest, Inc., ORD089452353, has received the following waste material:

GENERATOR:	PORT OF TACOMA
MANIFEST #:	011886640JJK
CWM TRACKING ID:	429521-01
PROFILE #:	OR321468
LINE ITEM:	9b.1
QUANTITY:	1 DT
RECEIVED DATE:	10/17/13
DISPOSAL PROCESS(ES):	LANDFILL
FINAL DISPOSAL LOCATION:	LANDFILL 13
DISPOSAL DATE:	10/17/13

I certify, on behalf of the above listed treatment facility, that to the best of my knowledge, the above-described waste material was managed in compliance with all applicable laws, regulations, permits and licenses on the date listed above.

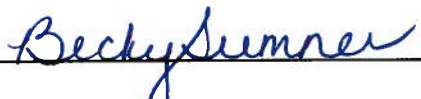

CWMNW RECORDS DEPARTMENT

Date: 10/22/13



CHEMICAL WASTE MANAGEMENT OF THE NW

17629 Cedar Springs Lane
Arlington, OR 97812
(541) 454-2643
(541) 454-3279 Fax

PORT OF TACOMA
WAD001882984
3400 TAYLOR WAY
TACOMA WA 98421

CERTIFICATE OF DISPOSAL

Chemical Waste Management of the Northwest, Inc., ORD089452353, has received the following waste material:

GENERATOR:	PORT OF TACOMA
MANIFEST #:	011886642JJK
CWM TRACKING ID:	429522-01
PROFILE #:	OR321468
LINE ITEM:	9b.1
QUANTITY:	1 DT
RECEIVED DATE:	10/17/13
DISPOSAL PROCESS(ES):	LANDFILL
FINAL DISPOSAL LOCATION:	LANDFILL 13
DISPOSAL DATE:	10/17/13

I certify, on behalf of the above listed treatment facility, that to the best of my knowledge, the above-described waste material was managed in compliance with all applicable laws, regulations, permits and licenses on the date listed above.



CWMNW RECORDS DEPARTMENT

Date: 10/22/13



CHEMICAL WASTE MANAGEMENT OF THE NW

17629 Cedar Springs Lane
Arlington, OR 97812
(541) 454-2643
(541) 454-3279 Fax

PORT OF TACOMA
WAD001882984
3400 TAYLOR WAY
TACOMA WA 98421

CERTIFICATE OF DISPOSAL

Chemical Waste Management of the Northwest, Inc., ORD089452353, has received the following waste material:

GENERATOR:	PORT OF TACOMA
MANIFEST #:	011886639JJK
CWM TRACKING ID:	429523-01
PROFILE #:	OR321468
LINE ITEM:	9b.1
QUANTITY:	1 DT
RECEIVED DATE:	10/17/13
DISPOSAL PROCESS(ES):	LANDFILL
FINAL DISPOSAL LOCATION:	LANDFILL 13
DISPOSAL DATE:	10/17/13

I certify, on behalf of the above listed treatment facility, that to the best of my knowledge, the above-described waste material was managed in compliance with all applicable laws, regulations, permits and licenses on the date listed above.

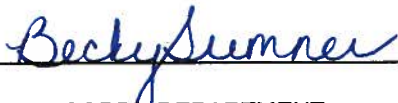

CWMNW RECORDS DEPARTMENT

Date: 10/22/13



CHEMICAL WASTE MANAGEMENT OF THE NW

17629 Cedar Springs Lane
Arlington, OR 97812
(541) 454-2643
(541) 454-3279 Fax

PORT OF TACOMA
WAD001882984
3400 TAYLOR WAY
TACOMA WA 98421

CERTIFICATE OF DISPOSAL

Chemical Waste Management of the Northwest, Inc., ORD089452353, has received the following waste material:

GENERATOR:	PORT OF TACOMA
MANIFEST #:	011886647JJK
CWM TRACKING ID:	429526-01
PROFILE #:	OR321468
LINE ITEM:	9b.1
QUANTITY:	1 DT
RECEIVED DATE:	10/17/13
DISPOSAL PROCESS(ES):	LANDFILL
FINAL DISPOSAL LOCATION:	LANDFILL 13
DISPOSAL DATE:	10/17/13

I certify, on behalf of the above listed treatment facility, that to the best of my knowledge, the above-described waste material was managed in compliance with all applicable laws, regulations, permits and licenses on the date listed above.



CWMNW RECORDS DEPARTMENT

Date: 10/22/13



CHEMICAL WASTE MANAGEMENT OF THE NW

17629 Cedar Springs Lane
Arlington, OR 97812
(541) 454-2643
(541) 454-3279 Fax

PORT OF TACOMA
WAD001882984
3400 TAYLOR WAY
TACOMA WA 98421

CERTIFICATE OF DISPOSAL

Chemical Waste Management of the Northwest, Inc., ORD089452353, has received the following waste material:

GENERATOR:	PORT OF TACOMA
MANIFEST #:	011886641JJK
CWM TRACKING ID:	429527-01
PROFILE #:	OR321468
LINE ITEM:	9b.1
QUANTITY:	1 DT
RECEIVED DATE:	10/17/13
DISPOSAL PROCESS(ES):	LANDFILL
FINAL DISPOSAL LOCATION:	LANDFILL 13
DISPOSAL DATE:	10/17/13

I certify, on behalf of the above listed treatment facility, that to the best of my knowledge, the above-described waste material was managed in compliance with all applicable laws, regulations, permits and licenses on the date listed above.

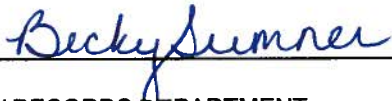

CWMNW RECORDS DEPARTMENT

Date: 10/22/13



CHEMICAL WASTE MANAGEMENT OF THE NW

17629 Cedar Springs Lane
Arlington, OR 97812
(541) 454-2643
(541) 454-3279 Fax

PORT OF TACOMA
WAD001882984
3400 TAYLOR WAY
TACOMA WA 98421

CERTIFICATE OF DISPOSAL

Chemical Waste Management of the Northwest, Inc., ORD089452353, has received the following waste material:

GENERATOR:	PORT OF TACOMA
MANIFEST #:	011886638JJK
CWM TRACKING ID:	429529-01
PROFILE #:	OR321468
LINE ITEM:	9b.1
QUANTITY:	1 DT
RECEIVED DATE:	10/17/13
DISPOSAL PROCESS(ES):	LANDFILL
FINAL DISPOSAL LOCATION:	LANDFILL 13
DISPOSAL DATE:	10/17/13

I certify, on behalf of the above listed treatment facility, that to the best of my knowledge, the above-described waste material was managed in compliance with all applicable laws, regulations, permits and licenses on the date listed above.

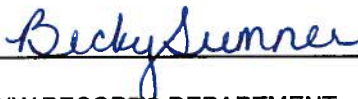

CWMNW RECORDS DEPARTMENT

Date: 10/22/13



CHEMICAL WASTE MANAGEMENT OF THE NW

17629 Cedar Springs Lane
Arlington, OR 97812
(541) 454-2643
(541) 454-3279 Fax

PORT OF TACOMA
WAD001882984
3400 TAYLOR WAY
TACOMA WA 98421

CERTIFICATE OF DISPOSAL

Chemical Waste Management of the Northwest, Inc., ORD089452353, has received the following waste material:

GENERATOR:	PORT OF TACOMA
MANIFEST #:	011886633JJK
CWM TRACKING ID:	429580-01
PROFILE #:	OR321468
LINE ITEM:	9b.1
QUANTITY:	1 DT
RECEIVED DATE:	10/18/13
DISPOSAL PROCESS(ES):	LANDFILL
FINAL DISPOSAL LOCATION:	LANDFILL 13
DISPOSAL DATE:	10/18/13

I certify, on behalf of the above listed treatment facility, that to the best of my knowledge, the above-described waste material was managed in compliance with all applicable laws, regulations, permits and licenses on the date listed above.

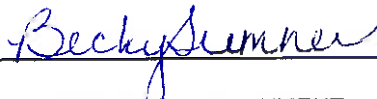

CWMNW RECORDS DEPARTMENT

Date: 10/24/13



CHEMICAL WASTE MANAGEMENT OF THE NW

17629 Cedar Springs Lane
Arlington, OR 97812
(541) 454-2643
(541) 454-3279 Fax

PORT OF TACOMA
WAD001882984
3400 TAYLOR WAY
TACOMA WA 98421

CERTIFICATE OF DISPOSAL

Chemical Waste Management of the Northwest, Inc., ORD089452353, has received the following waste material:

GENERATOR:	PORT OF TACOMA
MANIFEST #:	011886632JJK
CWM TRACKING ID:	429581-01
PROFILE #:	OR321468
LINE ITEM:	9b.1
QUANTITY:	1 DT
RECEIVED DATE:	10/18/13
DISPOSAL PROCESS(ES):	LANDFILL
FINAL DISPOSAL LOCATION:	LANDFILL 13
DISPOSAL DATE:	10/18/13

I certify, on behalf of the above listed treatment facility, that to the best of my knowledge, the above-described waste material was managed in compliance with all applicable laws, regulations, permits and licenses on the date listed above.

Becky Sumner

CWMNW RECORDS DEPARTMENT
Date: 10/24/13



CHEMICAL WASTE MANAGEMENT OF THE NW

17629 Cedar Springs Lane
Arlington, OR 97812
(541) 454-2643
(541) 454-3279 Fax

PORT OF TACOMA
WAD001882984
3400 TAYLOR WAY
TACOMA WA 98421

CERTIFICATE OF DISPOSAL

Chemical Waste Management of the Northwest, Inc., ORD089452353, has received the following waste material:

GENERATOR:	PORT OF TACOMA
MANIFEST #:	011886631JJK
CWM TRACKING ID:	429582-01
PROFILE #:	OR321468
LINE ITEM:	9b.1
QUANTITY:	1 DT
RECEIVED DATE:	10/18/13
DISPOSAL PROCESS(ES):	LANDFILL
FINAL DISPOSAL LOCATION:	LANDFILL 13
DISPOSAL DATE:	10/18/13

I certify, on behalf of the above listed treatment facility, that to the best of my knowledge, the above-described waste material was managed in compliance with all applicable laws, regulations, permits and licenses on the date listed above.

Becky Sumner

CWMNW RECORDS DEPARTMENT
Date: 10/24/13



CHEMICAL WASTE MANAGEMENT OF THE NW

17629 Cedar Springs Lane
Arlington, OR 97812
(541) 454-2643
(541) 454-3279 Fax

PORT OF TACOMA
WAD001882984
3400 TAYLOR WAY
TACOMA WA 98421

CERTIFICATE OF DISPOSAL

Chemical Waste Management of the Northwest, Inc., ORD089452353, has received the following waste material:

GENERATOR:	PORT OF TACOMA
MANIFEST #:	011886629JJK
CWM TRACKING ID:	429586-01
PROFILE #:	OR321468
LINE ITEM:	9b.1
QUANTITY:	1 DT
RECEIVED DATE:	10/18/13
DISPOSAL PROCESS(ES):	LANDFILL
FINAL DISPOSAL LOCATION:	LANDFILL 13
DISPOSAL DATE:	10/18/13

I certify, on behalf of the above listed treatment facility, that to the best of my knowledge, the above-described waste material was managed in compliance with all applicable laws, regulations, permits and licenses on the date listed above.



CWMNW RECORDS DEPARTMENT

Date: 10/24/13



CHEMICAL WASTE MANAGEMENT OF THE NW

17629 Cedar Springs Lane
Arlington, OR 97812
(541) 454-2643
(541) 454-3279 Fax

PORT OF TACOMA
WAD001882984
3400 TAYLOR WAY
TACOMA WA 98421

CERTIFICATE OF DISPOSAL

Chemical Waste Management of the Northwest, Inc., ORD089452353, has received the following waste material:

GENERATOR:	PORT OF TACOMA
MANIFEST #:	011886630JJK
CWM TRACKING ID:	429587-01
PROFILE #:	OR321468
LINE ITEM:	9b.1
QUANTITY:	1 DT
RECEIVED DATE:	10/18/13
DISPOSAL PROCESS(ES):	LANDFILL
FINAL DISPOSAL LOCATION:	LANDFILL 13
DISPOSAL DATE:	10/18/13

I certify, on behalf of the above listed treatment facility, that to the best of my knowledge, the above-described waste material was managed in compliance with all applicable laws, regulations, permits and licenses on the date listed above.

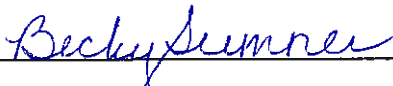

CWMNW RECORDS DEPARTMENT
Date: 10/24/13



CHEMICAL WASTE MANAGEMENT OF THE NW

17629 Cedar Springs Lane
Arlington, OR 97812
(541) 454-2643
(541) 454-3279 Fax

PORT OF TACOMA
WAD001882984
3400 TAYLOR WAY
TACOMA WA 98421

CERTIFICATE OF DISPOSAL

Chemical Waste Management of the Northwest, Inc., ORD089452353, has received the following waste material:

GENERATOR:	PORT OF TACOMA
MANIFEST #:	011886624JJK
CWM TRACKING ID:	429642-01
PROFILE #:	OR321468
LINE ITEM:	9b.1
QUANTITY:	1 DT
RECEIVED DATE:	10/21/13
DISPOSAL PROCESS(ES):	LANDFILL
FINAL DISPOSAL LOCATION:	LANDFILL 13
DISPOSAL DATE:	10/21/13

I certify, on behalf of the above listed treatment facility, that to the best of my knowledge, the above-described waste material was managed in compliance with all applicable laws, regulations, permits and licenses on the date listed above.

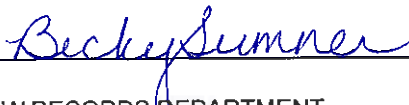

CWMNW RECORDS DEPARTMENT
Date: 10/24/13



CHEMICAL WASTE MANAGEMENT OF THE NW

17629 Cedar Springs Lane
Arlington, OR 97812
(541) 454-2643
(541) 454-3279 Fax

PORT OF TACOMA
WAD001882984
3400 TAYLOR WAY
TACOMA WA 98421

CERTIFICATE OF DISPOSAL

Chemical Waste Management of the Northwest, Inc., ORD089452353, has received the following waste material:

GENERATOR:	PORT OF TACOMA
MANIFEST #:	011886625JJK
CWM TRACKING ID:	429643-01
PROFILE #:	OR321468
LINE ITEM:	9b.1
QUANTITY:	1 DT
RECEIVED DATE:	10/21/13
DISPOSAL PROCESS(ES):	LANDFILL
FINAL DISPOSAL LOCATION:	LANDFILL 13
DISPOSAL DATE:	10/21/13

I certify, on behalf of the above listed treatment facility, that to the best of my knowledge, the above-described waste material was managed in compliance with all applicable laws, regulations, permits and licenses on the date listed above.

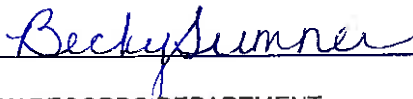

CWMNW RECORDS DEPARTMENT

Date: 10/24/13



CHEMICAL WASTE MANAGEMENT OF THE NW

17629 Cedar Springs Lane
Arlington, OR 97812
(541) 454-2643
(541) 454-3279 Fax

PORT OF TACOMA
WAD001882984
3400 TAYLOR WAY
TACOMA WA 98421

CERTIFICATE OF DISPOSAL

Chemical Waste Management of the Northwest, Inc., ORD089452353, has received the following waste material:

GENERATOR:	PORT OF TACOMA
MANIFEST #:	011886626JJK
CWM TRACKING ID:	429644-01
PROFILE #:	OR321468
LINE ITEM:	9b.1
QUANTITY:	1 DT
RECEIVED DATE:	10/21/13
DISPOSAL PROCESS(ES):	LANDFILL
FINAL DISPOSAL LOCATION:	LANDFILL 13
DISPOSAL DATE:	10/21/13

I certify, on behalf of the above listed treatment facility, that to the best of my knowledge, the above-described waste material was managed in compliance with all applicable laws, regulations, permits and licenses on the date listed above.



 CWMNW RECORDS DEPARTMENT
 Date: 10/24/13





CHEMICAL WASTE MANAGEMENT OF THE NW

17629 Cedar Springs Lane
Arlington, OR 97812
(541) 454-2643
(541) 454-3279 Fax

PORT OF TACOMA
WAD001882984
3400 TAYLOR WAY
TACOMA WA 98421

CERTIFICATE OF DISPOSAL

Chemical Waste Management of the Northwest, Inc., ORD089452353, has received the following waste material:

GENERATOR:	PORT OF TACOMA
MANIFEST #:	011886627JJK
CWM TRACKING ID:	429647-01
PROFILE #:	OR321468
LINE ITEM:	9b.1
QUANTITY:	1 DT
RECEIVED DATE:	10/21/13
DISPOSAL PROCESS(ES):	LANDFILL
FINAL DISPOSAL LOCATION:	LANDFILL 13
DISPOSAL DATE:	10/21/13

I certify, on behalf of the above listed treatment facility, that to the best of my knowledge, the above-described waste material was managed in compliance with all applicable laws, regulations, permits and licenses on the date listed above.



CWMNW RECORDS DEPARTMENT

Date: 10/24/13



CHEMICAL WASTE MANAGEMENT OF THE NW

17629 Cedar Springs Lane
Arlington, OR 97812
(541) 454-2643
(541) 454-3279 Fax

PORT OF TACOMA
WAD001882984
3400 TAYLOR WAY
TACOMA WA 98421

CERTIFICATE OF DISPOSAL

Chemical Waste Management of the Northwest, Inc., ORD089452353, has received the following waste material:

GENERATOR:	PORT OF TACOMA
MANIFEST #:	011886621JJK
CWM TRACKING ID:	429650-01
PROFILE #:	OR321468
LINE ITEM:	9b.1
QUANTITY:	1 DT
RECEIVED DATE:	10/21/13
DISPOSAL PROCESS(ES):	LANDFILL
FINAL DISPOSAL LOCATION:	LANDFILL 13
DISPOSAL DATE:	10/21/13

I certify, on behalf of the above listed treatment facility, that to the best of my knowledge, the above-described waste material was managed in compliance with all applicable laws, regulations, permits and licenses on the date listed above.



CWMNW RECORDS DEPARTMENT
Date: 10/24/13



CHEMICAL WASTE MANAGEMENT OF THE NW

17629 Cedar Springs Lane
Arlington, OR 97812
(541) 454-2643
(541) 454-3279 Fax

PORT OF TACOMA
WAD001882984
3400 TAYLOR WAY
TACOMA WA 98421

CERTIFICATE OF DISPOSAL

Chemical Waste Management of the Northwest, Inc., ORD089452353, has received the following waste material:

GENERATOR:	PORT OF TACOMA
MANIFEST #:	011886613JJK
CWM TRACKING ID:	429654-01
PROFILE #:	OR321468
LINE ITEM:	9b.1
QUANTITY:	1 DT
RECEIVED DATE:	10/21/13
DISPOSAL PROCESS(ES):	LANDFILL
FINAL DISPOSAL LOCATION:	LANDFILL 13
DISPOSAL DATE:	10/21/13

I certify, on behalf of the above listed treatment facility, that to the best of my knowledge, the above-described waste material was managed in compliance with all applicable laws, regulations, permits and licenses on the date listed above.



CWMNW RECORDS DEPARTMENT
Date: 10/24/13



CHEMICAL WASTE MANAGEMENT OF THE NW

17629 Cedar Springs Lane
Arlington, OR 97812
(541) 454-2643
(541) 454-3279 Fax

PORT OF TACOMA
WAD001882984
3400 TAYLOR WAY
TACOMA WA 98421

CERTIFICATE OF DISPOSAL

Chemical Waste Management of the Northwest, Inc., ORD089452353, has received the following waste material:

GENERATOR:	PORT OF TACOMA
MANIFEST #:	011886622JJK
CWM TRACKING ID:	429655-01
PROFILE #:	OR321468
LINE ITEM:	9b.1
QUANTITY:	1 DT
RECEIVED DATE:	10/21/13
DISPOSAL PROCESS(ES):	LANDFILL
FINAL DISPOSAL LOCATION:	LANDFILL 13
DISPOSAL DATE:	10/21/13

I certify, on behalf of the above listed treatment facility, that to the best of my knowledge, the above-described waste material was managed in compliance with all applicable laws, regulations, permits and licenses on the date listed above.

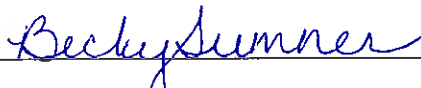

CWMNW RECORDS DEPARTMENT
Date: 10/24/13



CHEMICAL WASTE MANAGEMENT OF THE NW

17629 Cedar Springs Lane
Arlington, OR 97812
(541) 454-2643
(541) 454-3279 Fax

PORT OF TACOMA
WAD001882984
3400 TAYLOR WAY
TACOMA WA 98421

CERTIFICATE OF DISPOSAL

Chemical Waste Management of the Northwest, Inc., ORD089452353, has received the following waste material:

GENERATOR:	PORT OF TACOMA
MANIFEST #:	011886652JJK
CWM TRACKING ID:	429657-01
PROFILE #:	OR321468
LINE ITEM:	9b.1
QUANTITY:	1 DT
RECEIVED DATE:	10/21/13
DISPOSAL PROCESS(ES):	LANDFILL
FINAL DISPOSAL LOCATION:	LANDFILL 13
DISPOSAL DATE:	10/21/13

I certify, on behalf of the above listed treatment facility, that to the best of my knowledge, the above-described waste material was managed in compliance with all applicable laws, regulations, permits and licenses on the date listed above.

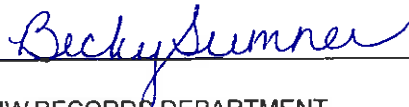

CWMNW RECORDS DEPARTMENT
Date: 10/24/13



CHEMICAL WASTE MANAGEMENT OF THE NW

17629 Cedar Springs Lane
Arlington, OR 97812
(541) 454-2643
(541) 454-3279 Fax

PORT OF TACOMA
WAD001882984
3400 TAYLOR WAY
TACOMA WA 98421

CERTIFICATE OF DISPOSAL

Chemical Waste Management of the Northwest, Inc., ORD089452353, has received the following waste material:

GENERATOR:	PORT OF TACOMA
MANIFEST #:	011886628JJK
CWM TRACKING ID:	429658-01
PROFILE #:	OR321468
LINE ITEM:	9b.1
QUANTITY:	1 DT
RECEIVED DATE:	10/21/13
DISPOSAL PROCESS(ES):	LANDFILL
FINAL DISPOSAL LOCATION:	LANDFILL 13
DISPOSAL DATE:	10/21/13

I certify, on behalf of the above listed treatment facility, that to the best of my knowledge, the above-described waste material was managed in compliance with all applicable laws, regulations, permits and licenses on the date listed above.

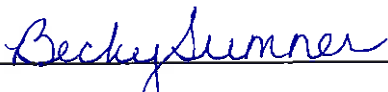

CWMNW RECORDS DEPARTMENT
Date: 10/24/13



CHEMICAL WASTE MANAGEMENT OF THE NW

17629 Cedar Springs Lane
Arlington, OR 97812
(541) 454-2643
(541) 454-3279 Fax

PORT OF TACOMA
WAD001882984
3400 TAYLOR WAY
TACOMA WA 98421

CERTIFICATE OF DISPOSAL

Chemical Waste Management of the Northwest, Inc., ORD089452353, has received the following waste material:

GENERATOR:	PORT OF TACOMA
MANIFEST #:	011886615JJK
CWM TRACKING ID:	429661-01
PROFILE #:	OR321468
LINE ITEM:	9b.1
QUANTITY:	1 DT
RECEIVED DATE:	10/21/13
DISPOSAL PROCESS(ES):	LANDFILL
FINAL DISPOSAL LOCATION:	LANDFILL 13
DISPOSAL DATE:	10/21/13

I certify, on behalf of the above listed treatment facility, that to the best of my knowledge, the above-described waste material was managed in compliance with all applicable laws, regulations, permits and licenses on the date listed above.



CWMNW RECORDS DEPARTMENT
Date: 10/24/13



CHEMICAL WASTE MANAGEMENT OF THE NW

17629 Cedar Springs Lane
Arlington, OR 97812
(541) 454-2643
(541) 454-3279 Fax

PORT OF TACOMA
WAD001882984
3400 TAYLOR WAY
TACOMA WA 98421

CERTIFICATE OF DISPOSAL

Chemical Waste Management of the Northwest, Inc., ORD089452353, has received the following waste material:

GENERATOR:	PORT OF TACOMA
MANIFEST #:	011886614JJK
CWM TRACKING ID:	429662-01
PROFILE #:	OR321468
LINE ITEM:	9b.1
QUANTITY:	1 DT
RECEIVED DATE:	10/21/13
DISPOSAL PROCESS(ES):	LANDFILL
FINAL DISPOSAL LOCATION:	LANDFILL 13
DISPOSAL DATE:	10/21/13

I certify, on behalf of the above listed treatment facility, that to the best of my knowledge, the above-described waste material was managed in compliance with all applicable laws, regulations, permits and licenses on the date listed above.

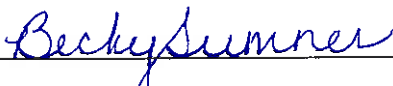

CWMNW RECORDS DEPARTMENT
Date: 10/24/13



CHEMICAL WASTE MANAGEMENT OF THE NW

17629 Cedar Springs Lane
Arlington, OR 97812
(541) 454-2643
(541) 454-3279 Fax

PORT OF TACOMA
WAD001882984
3400 TAYLOR WAY
TACOMA WA 98421

CERTIFICATE OF DISPOSAL

Chemical Waste Management of the Northwest, Inc., ORD089452353, has received the following waste material:

GENERATOR:	PORT OF TACOMA
MANIFEST #:	011886616JJK
CWM TRACKING ID:	429664-01
PROFILE #:	OR321468
LINE ITEM:	9b.1
QUANTITY:	1 DT
RECEIVED DATE:	10/21/13
DISPOSAL PROCESS(ES):	LANDFILL
FINAL DISPOSAL LOCATION:	LANDFILL 13
DISPOSAL DATE:	10/21/13

I certify, on behalf of the above listed treatment facility, that to the best of my knowledge, the above-described waste material was managed in compliance with all applicable laws, regulations, permits and licenses on the date listed above.

CWMNW RECORDS DEPARTMENT

Date: 10/24/13



CHEMICAL WASTE MANAGEMENT OF THE NW

17629 Cedar Springs Lane
Arlington, OR 97812
(541) 454-2643
(541) 454-3279 Fax

PORT OF TACOMA
WAD001882984
3400 TAYLOR WAY
TACOMA WA 98421

CERTIFICATE OF DISPOSAL

Chemical Waste Management of the Northwest, Inc., ORD089452353, has received the following waste material:

GENERATOR:	PORT OF TACOMA
MANIFEST #:	011886623JJK
CWM TRACKING ID:	429666-01
PROFILE #:	OR321468
LINE ITEM:	9b.1
QUANTITY:	1 DT
RECEIVED DATE:	10/21/13
DISPOSAL PROCESS(ES):	LANDFILL
FINAL DISPOSAL LOCATION:	LANDFILL 13
DISPOSAL DATE:	10/21/13

I certify, on behalf of the above listed treatment facility, that to the best of my knowledge, the above-described waste material was managed in compliance with all applicable laws, regulations, permits and licenses on the date listed above.



CWMNW RECORDS DEPARTMENT
Date: 10/24/13



CHEMICAL WASTE MANAGEMENT OF THE NW

17629 Cedar Springs Lane
Arlington, OR 97812
(541) 454-2643
(541) 454-3279 Fax

PORT OF TACOMA
WAD001882984
3400 TAYLOR WAY
TACOMA WA 98421

CERTIFICATE OF DISPOSAL

Chemical Waste Management of the Northwest, Inc., ORD089452353, has received the following waste material:

GENERATOR:	PORT OF TACOMA
MANIFEST #:	011886618JJK
CWM TRACKING ID:	429669-01
PROFILE #:	OR321468
LINE ITEM:	9b.1
QUANTITY:	1 DT
RECEIVED DATE:	10/21/13
DISPOSAL PROCESS(ES):	LANDFILL
FINAL DISPOSAL LOCATION:	LANDFILL 13
DISPOSAL DATE:	10/21/13

I certify, on behalf of the above listed treatment facility, that to the best of my knowledge, the above-described waste material was managed in compliance with all applicable laws, regulations, permits and licenses on the date listed above.



CWMNW RECORDS DEPARTMENT

Date: 10/24/13



CHEMICAL WASTE MANAGEMENT OF THE NW

17629 Cedar Springs Lane
Arlington, OR 97812
(541) 454-2643
(541) 454-3279 Fax

PORT OF TACOMA
WAD001882984
3400 TAYLOR WAY
TACOMA WA 98421

CERTIFICATE OF DISPOSAL

Chemical Waste Management of the Northwest, Inc., ORD089452353, has received the following waste material:

GENERATOR: PORT OF TACOMA
MANIFEST #: 011886617JJK
CWM TRACKING ID: 429671-01
PROFILE #: OR321468
LINE ITEM: 9b.1
QUANTITY: 1 DT
RECEIVED DATE: 10/21/13

DISPOSAL PROCESS(ES): LANDFILL
FINAL DISPOSAL LOCATION: LANDFILL 13
DISPOSAL DATE: 10/21/13

I certify, on behalf of the above listed treatment facility, that to the best of my knowledge, the above-described waste material was managed in compliance with all applicable laws, regulations, permits and licenses on the date listed above.

Becky Sumner

CWMNW RECORDS DEPARTMENT

Date: 10/24/13



WASTE MANAGEMENT
17629 Cedar Springs Lane
Arlington, OR 97812

PORT OF TACOMA
WAD001882984
3400 TAYLOR WAY
TACOMA WA 98421

CERTIFICATE OF DISPOSAL

Chemical Waste Management of the Northwest, Inc., ORD089452353, has received the following waste material:

GENERATOR:	PORT OF TACOMA	
MANIFEST #:	011886995JJK	
CWM TRACKING ID:	429708-01	
PROFILE #:	OR321468	
LINE ITEM:	9b.1	
QUANTITY:	1 DT	
RECEIVED DATE:	10/22/13	
DISPOSAL PROCESS(ES):	LANDFILL	
FINAL DISPOSAL LOCATION:	LANDFILL	13
DISPOSAL DATE:	10/22/13	

I certify, on behalf of the above listed treatment facility, that to the best of my knowledge, the above-described waste material was managed in compliance with all applicable laws, regulations, permits and licenses on the date listed above.

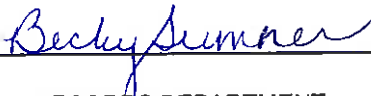

CWMNW RECORDS DEPARTMENT
Date:

10/25/13



CHEMICAL WASTE MANAGEMENT OF THE NW

17629 Cedar Springs Lane
Arlington, OR 97812
(541) 454-2643
(541) 454-3279 Fax

PORT OF TACOMA
WAD001882984
3400 TAYLOR WAY
TACOMA WA 98421

CERTIFICATE OF DISPOSAL

Chemical Waste Management of the Northwest, Inc., ORD089452353, has received the following waste material:

GENERATOR:	PORT OF TACOMA
MANIFEST #:	011886992JJK
CWM TRACKING ID:	429700-01
PROFILE #:	OR321468
LINE ITEM:	9b.1
QUANTITY:	1 DT
RECEIVED DATE:	10/22/13
DISPOSAL PROCESS(ES):	LANDFILL
FINAL DISPOSAL LOCATION:	LANDFILL 13
DISPOSAL DATE:	10/22/13

I certify, on behalf of the above listed treatment facility, that to the best of my knowledge, the above-described waste material was managed in compliance with all applicable laws, regulations, permits and licenses on the date listed above.

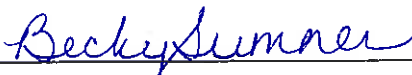

CWMNW RECORDS DEPARTMENT
Date: 10/24/13



CHEMICAL WASTE MANAGEMENT OF THE NW

17629 Cedar Springs Lane
Arlington, OR 97812
(541) 454-2643
(541) 454-3279 Fax

PORT OF TACOMA
WAD001882984
3400 TAYLOR WAY
TACOMA WA 98421

CERTIFICATE OF DISPOSAL

Chemical Waste Management of the Northwest, Inc., ORD089452353, has received the following waste material:

GENERATOR:	PORT OF TACOMA
MANIFEST #:	011886993JJK
CWM TRACKING ID:	429701-01
PROFILE #:	OR321468
LINE ITEM:	9b.1
QUANTITY:	1 DT
RECEIVED DATE:	10/22/13
DISPOSAL PROCESS(ES):	LANDFILL
FINAL DISPOSAL LOCATION:	LANDFILL 13
DISPOSAL DATE:	10/22/13

I certify, on behalf of the above listed treatment facility, that to the best of my knowledge, the above-described waste material was managed in compliance with all applicable laws, regulations, permits and licenses on the date listed above.



CWMNW RECORDS DEPARTMENT
Date: 10/24/13



CHEMICAL WASTE MANAGEMENT OF THE NW

17629 Cedar Springs Lane
Arlington, OR 97812
(541) 454-2643
(541) 454-3279 Fax

PORT OF TACOMA
WAD001882984
3400 TAYLOR WAY
TACOMA WA 98421

CERTIFICATE OF DISPOSAL

Chemical Waste Management of the Northwest, Inc., ORD089452353, has received the following waste material:

GENERATOR:	PORT OF TACOMA
MANIFEST #:	011886994JJK
CWM TRACKING ID:	429702-01
PROFILE #:	OR321468
LINE ITEM:	9b.1
QUANTITY:	1 DT
RECEIVED DATE:	10/22/13
DISPOSAL PROCESS(ES):	LANDFILL
FINAL DISPOSAL LOCATION:	LANDFILL 13
DISPOSAL DATE:	10/22/13

I certify, on behalf of the above listed treatment facility, that to the best of my knowledge, the above-described waste material was managed in compliance with all applicable laws, regulations, permits and licenses on the date listed above.



CWMNW RECORDS DEPARTMENT
Date: 10/24/13





CHEMICAL WASTE MANAGEMENT OF THE NW

17629 Cedar Springs Lane
Arlington, OR 97812
(541) 454-2643
(541) 454-3279 Fax

PORT OF TACOMA
WAD001882984
3400 TAYLOR WAY
TACOMA WA 98421

CERTIFICATE OF DISPOSAL

Chemical Waste Management of the Northwest, Inc., ORD089452353, has received the following waste material:

GENERATOR:	PORT OF TACOMA
MANIFEST #:	011886999JJK
CWM TRACKING ID:	429703-01
PROFILE #:	OR321468
LINE ITEM:	9b.1
QUANTITY:	1 DT
RECEIVED DATE:	10/22/13
DISPOSAL PROCESS(ES):	LANDFILL
FINAL DISPOSAL LOCATION:	LANDFILL 13
DISPOSAL DATE:	10/22/13

I certify, on behalf of the above listed treatment facility, that to the best of my knowledge, the above-described waste material was managed in compliance with all applicable laws, regulations, permits and licenses on the date listed above.

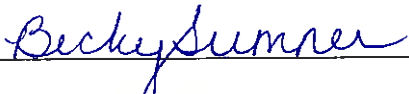

CWMNW RECORDS DEPARTMENT

Date: 10/24/13



CHEMICAL WASTE MANAGEMENT OF THE NW

17629 Cedar Springs Lane
Arlington, OR 97812
(541) 454-2643
(541) 454-3279 Fax

PORT OF TACOMA
WAD001882984
3400 TAYLOR WAY
TACOMA WA 98421

CERTIFICATE OF DISPOSAL

Chemical Waste Management of the Northwest, Inc., ORD089452353, has received the following waste material:

GENERATOR:	PORT OF TACOMA
MANIFEST #:	011886998JJK
CWM TRACKING ID:	429705-01
PROFILE #:	OR321468
LINE ITEM:	9b.1
QUANTITY:	1 DT
RECEIVED DATE:	10/22/13
DISPOSAL PROCESS(ES):	LANDFILL
FINAL DISPOSAL LOCATION:	LANDFILL 13
DISPOSAL DATE:	10/22/13

I certify, on behalf of the above listed treatment facility, that to the best of my knowledge, the above-described waste material was managed in compliance with all applicable laws, regulations, permits and licenses on the date listed above.



CWMNW RECORDS DEPARTMENT
Date: 10/24/13



CHEMICAL WASTE MANAGEMENT OF THE NW

17629 Cedar Springs Lane
Arlington, OR 97812
(541) 454-2643
(541) 454-3279 Fax

PORT OF TACOMA
WAD001882984
3400 TAYLOR WAY
TACOMA WA 98421

CERTIFICATE OF DISPOSAL

Chemical Waste Management of the Northwest, Inc., ORD089452353, has received the following waste material:

GENERATOR:	PORT OF TACOMA
MANIFEST #:	011886609JJK
CWM TRACKING ID:	429706-01
PROFILE #:	OR321468
LINE ITEM:	9b.1
QUANTITY:	1 DT
RECEIVED DATE:	10/22/13
DISPOSAL PROCESS(ES):	LANDFILL
FINAL DISPOSAL LOCATION:	LANDFILL 13
DISPOSAL DATE:	10/22/13

I certify, on behalf of the above listed treatment facility, that to the best of my knowledge, the above-described waste material was managed in compliance with all applicable laws, regulations, permits and licenses on the date listed above.



CWMNW RECORDS DEPARTMENT

Date: 10/24/13



CHEMICAL WASTE MANAGEMENT OF THE NW

17629 Cedar Springs Lane
Arlington, OR 97812
(541) 454-2643
(541) 454-3279 Fax

PORT OF TACOMA
WAD001882984
3400 TAYLOR WAY
TACOMA WA 98421

CERTIFICATE OF DISPOSAL

Chemical Waste Management of the Northwest, Inc., ORD089452353, has received the following waste material:

GENERATOR:	PORT OF TACOMA
MANIFEST #:	011886608JJK
CWM TRACKING ID:	429710-01
PROFILE #:	OR321468
LINE ITEM:	9b.1
QUANTITY:	1 DT
RECEIVED DATE:	10/22/13
DISPOSAL PROCESS(ES):	LANDFILL
FINAL DISPOSAL LOCATION:	LANDFILL 13
DISPOSAL DATE:	10/22/13

I certify, on behalf of the above listed treatment facility, that to the best of my knowledge, the above-described waste material was managed in compliance with all applicable laws, regulations, permits and licenses on the date listed above.



CWMNW RECORDS DEPARTMENT
Date: 10/24/13



CHEMICAL WASTE MANAGEMENT OF THE NW

17629 Cedar Springs Lane
Arlington, OR 97812
(541) 454-2643
(541) 454-3279 Fax

PORT OF TACOMA
WAD001882984
3400 TAYLOR WAY
TACOMA WA 98421

CERTIFICATE OF DISPOSAL

Chemical Waste Management of the Northwest, Inc., ORD089452353, has received the following waste material:

GENERATOR:	PORT OF TACOMA
MANIFEST #:	011886997JJK
CWM TRACKING ID:	429711-01
PROFILE #:	OR321468
LINE ITEM:	9b.1
QUANTITY:	1 DT
RECEIVED DATE:	10/22/13
DISPOSAL PROCESS(ES):	LANDFILL
FINAL DISPOSAL LOCATION:	LANDFILL 13
DISPOSAL DATE:	10/22/13

I certify, on behalf of the above listed treatment facility, that to the best of my knowledge, the above-described waste material was managed in compliance with all applicable laws, regulations, permits and licenses on the date listed above.

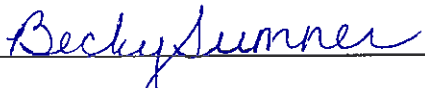

CWMNW RECORDS DEPARTMENT
Date: 10/24/13



CHEMICAL WASTE MANAGEMENT OF THE NW

17629 Cedar Springs Lane
Arlington, OR 97812
(541) 454-2643
(541) 454-3279 Fax

PORT OF TACOMA
WAD001882984
3400 TAYLOR WAY
TACOMA WA 98421

CERTIFICATE OF DISPOSAL

Chemical Waste Management of the Northwest, Inc., ORD089452353, has received the following waste material:

GENERATOR:	PORT OF TACOMA
MANIFEST #:	011886610JJK
CWM TRACKING ID:	429713-01
PROFILE #:	OR321468
LINE ITEM:	9b.1
QUANTITY:	1 DT
RECEIVED DATE:	10/22/13
DISPOSAL PROCESS(ES):	LANDFILL
FINAL DISPOSAL LOCATION:	LANDFILL 13
DISPOSAL DATE:	10/22/13

I certify, on behalf of the above listed treatment facility, that to the best of my knowledge, the above-described waste material was managed in compliance with all applicable laws, regulations, permits and licenses on the date listed above.

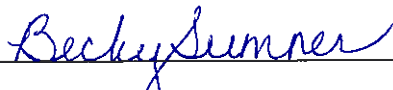

CWMNW RECORDS DEPARTMENT
Date: 10/24/13



CHEMICAL WASTE MANAGEMENT OF THE NW

17629 Cedar Springs Lane
Arlington, OR 97812
(541) 454-2643
(541) 454-3279 Fax

PORT OF TACOMA
WAD001882984
3400 TAYLOR WAY
TACOMA WA 98421

CERTIFICATE OF DISPOSAL

Chemical Waste Management of the Northwest, Inc., ORD089452353, has received the following waste material:

GENERATOR:	PORT OF TACOMA
MANIFEST #:	011886612JJK
CWM TRACKING ID:	429717-01
PROFILE #:	OR321468
LINE ITEM:	9b.1
QUANTITY:	1 DT
RECEIVED DATE:	10/22/13
DISPOSAL PROCESS(ES):	LANDFILL
FINAL DISPOSAL LOCATION:	LANDFILL 13
DISPOSAL DATE:	10/22/13

I certify, on behalf of the above listed treatment facility, that to the best of my knowledge, the above-described waste material was managed in compliance with all applicable laws, regulations, permits and licenses on the date listed above.



CWMNW RECORDS DEPARTMENT
Date: 10/24/13



CHEMICAL WASTE MANAGEMENT OF THE NW

17629 Cedar Springs Lane
Arlington, OR 97812
(541) 454-2643
(541) 454-3279 Fax

PORT OF TACOMA
WAD001882984
3400 TAYLOR WAY
TACOMA WA 98421

CERTIFICATE OF DISPOSAL

Chemical Waste Management of the Northwest, Inc., ORD089452353, has received the following waste material:

GENERATOR:	PORT OF TACOMA
MANIFEST #:	011886996JJK
CWM TRACKING ID:	429720-01
PROFILE #:	OR321468
LINE ITEM:	9b.1
QUANTITY:	1 DT
RECEIVED DATE:	10/22/13
DISPOSAL PROCESS(ES):	LANDFILL
FINAL DISPOSAL LOCATION:	LANDFILL 13
DISPOSAL DATE:	10/22/13

I certify, on behalf of the above listed treatment facility, that to the best of my knowledge, the above-described waste material was managed in compliance with all applicable laws, regulations, permits and licenses on the date listed above.

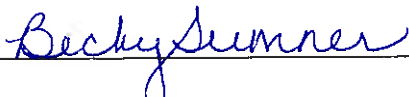

CWMNW RECORDS DEPARTMENT
Date: 10/24/13



CHEMICAL WASTE MANAGEMENT OF THE NW

17629 Cedar Springs Lane
Arlington, OR 97812
(541) 454-2643
(541) 454-3279 Fax

PORT OF TACOMA
WAD001882984
3400 TAYLOR WAY
TACOMA WA 98421

CERTIFICATE OF DISPOSAL

Chemical Waste Management of the Northwest, Inc., ORD089452353, has received the following waste material:

GENERATOR:	PORT OF TACOMA
MANIFEST #:	011886607JJK
CWM TRACKING ID:	429722-01
PROFILE #:	OR321468
LINE ITEM:	9b.1
QUANTITY:	1 DT
RECEIVED DATE:	10/22/13
DISPOSAL PROCESS(ES):	LANDFILL
FINAL DISPOSAL LOCATION:	LANDFILL 13
DISPOSAL DATE:	10/22/13

I certify, on behalf of the above listed treatment facility, that to the best of my knowledge, the above-described waste material was managed in compliance with all applicable laws, regulations, permits and licenses on the date listed above.



CWMNW RECORDS DEPARTMENT

Date: 10/24/13



CHEMICAL WASTE MANAGEMENT OF THE NW

17629 Cedar Springs Lane
Arlington, OR 97812
(541) 454-2643
(541) 454-3279 Fax

PORT OF TACOMA
WAD001882984
3400 TAYLOR WAY
TACOMA WA 98421

CERTIFICATE OF DISPOSAL

Chemical Waste Management of the Northwest, Inc., ORD089452353, has received the following waste material:

GENERATOR:	PORT OF TACOMA
MANIFEST #:	011886611JJK
CWM TRACKING ID:	429726-01
PROFILE #:	OR321468
LINE ITEM:	9b.1
QUANTITY:	1 DT
RECEIVED DATE:	10/22/13
DISPOSAL PROCESS(ES):	LANDFILL
FINAL DISPOSAL LOCATION:	LANDFILL 13
DISPOSAL DATE:	10/22/13

I certify, on behalf of the above listed treatment facility, that to the best of my knowledge, the above-described waste material was managed in compliance with all applicable laws, regulations, permits and licenses on the date listed above.

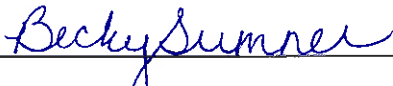

CWMNW RECORDS DEPARTMENT
Date: 10/24/13



CHEMICAL WASTE MANAGEMENT OF THE NW

17629 Cedar Springs Lane
Arlington, OR 97812
(541) 454-2643
(541) 454-3279 Fax

PORT OF TACOMA
WAD001882984
3400 TAYLOR WAY
TACOMA WA 98421

CERTIFICATE OF DISPOSAL

Chemical Waste Management of the Northwest, Inc., ORD089452353, has received the following waste material:

GENERATOR:	PORT OF TACOMA
MANIFEST #:	011886620JJK
CWM TRACKING ID:	429727-01
PROFILE #:	OR321468
LINE ITEM:	9b.1
QUANTITY:	1 DT
RECEIVED DATE:	10/22/13
DISPOSAL PROCESS(ES):	LANDFILL
FINAL DISPOSAL LOCATION:	LANDFILL 13
DISPOSAL DATE:	10/22/13

I certify, on behalf of the above listed treatment facility, that to the best of my knowledge, the above-described waste material was managed in compliance with all applicable laws, regulations, permits and licenses on the date listed above.

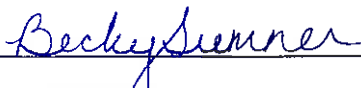

CWMNW RECORDS DEPARTMENT
Date: 10/24/13



WASTE MANAGEMENT
17629 Cedar Springs Lane
Arlington, OR 97812

PORT OF TACOMA
WAD001882984
3400 TAYLOR WAY
TACOMA WA 98421

CERTIFICATE OF DISPOSAL

Chemical Waste Management of the Northwest, Inc., ORD089452353, has received the following waste material:

GENERATOR:	PORT OF TACOMA
MANIFEST #:	011886619JJK
CWM TRACKING ID:	429737-01
PROFILE #:	OR321468
LINE ITEM:	9b.1
QUANTITY:	1 DT
RECEIVED DATE:	10/23/13
DISPOSAL PROCESS(ES):	LANDFILL
FINAL DISPOSAL LOCATION:	LANDFILL 13
DISPOSAL DATE:	10/23/13

I certify, on behalf of the above listed treatment facility, that to the best of my knowledge, the above-described waste material was managed in compliance with all applicable laws, regulations, permits and licenses on the date listed above.

Becky Sumner

CWMNW RECORDS DEPARTMENT

Date: 10/25/13



WASTE MANAGEMENT
17629 Cedar Springs Lane
Arlington, OR 97812

PORT OF TACOMA
WAD001882984
3400 TAYLOR WAY
TACOMA WA 98421

CERTIFICATE OF DISPOSAL

Chemical Waste Management of the Northwest, Inc., ORD089452353, has received the following waste material:

GENERATOR:	PORT OF TACOMA
MANIFEST #:	011886605JJK
CWM TRACKING ID:	429758-01
PROFILE #:	OR321468
LINE ITEM:	9b.1
QUANTITY:	1 DT
RECEIVED DATE:	10/23/13
DISPOSAL PROCESS(ES):	LANDFILL
FINAL DISPOSAL LOCATION:	LANDFILL 13
DISPOSAL DATE:	10/23/13

I certify, on behalf of the above listed treatment facility, that to the best of my knowledge, the above-described waste material was managed in compliance with all applicable laws, regulations, permits and licenses on the date listed above.

Becky Sumner

CWMNW RECORDS DEPARTMENT

Date: 10/25/13



WASTE MANAGEMENT
17629 Cedar Springs Lane
Arlington, OR 97812

PORT OF TACOMA
WAD001882984
3400 TAYLOR WAY
TACOMA WA 98421

CERTIFICATE OF DISPOSAL

Chemical Waste Management of the Northwest, Inc., ORD089452353, has received the following waste material:

GENERATOR:	PORT OF TACOMA
MANIFEST #:	011886604JJK
CWM TRACKING ID:	429759-01
PROFILE #:	OR321468
LINE ITEM:	9b.1
QUANTITY:	1 DT
RECEIVED DATE:	10/23/13
DISPOSAL PROCESS(ES):	LANDFILL
FINAL DISPOSAL LOCATION:	LANDFILL 13
DISPOSAL DATE:	10/23/13

I certify, on behalf of the above listed treatment facility, that to the best of my knowledge, the above-described waste material was managed in compliance with all applicable laws, regulations, permits and licenses on the date listed above.

Becky Sumner

CWMNW RECORDS DEPARTMENT

Date: 10/25/13



WASTE MANAGEMENT
17629 Cedar Springs Lane
Arlington, OR 97812

PORT OF TACOMA
WAD001882984
3400 TAYLOR WAY
TACOMA WA 98421

CERTIFICATE OF DISPOSAL

Chemical Waste Management of the Northwest, Inc., ORD089452353, has received the following waste material:

GENERATOR:	PORT OF TACOMA
MANIFEST #:	011886601JJK
CWM TRACKING ID:	429762-01
PROFILE #:	OR321468
LINE ITEM:	9b.1
QUANTITY:	1 DT
RECEIVED DATE:	10/23/13
DISPOSAL PROCESS(ES):	LANDFILL
FINAL DISPOSAL LOCATION:	LANDFILL 13
DISPOSAL DATE:	10/23/13

I certify, on behalf of the above listed treatment facility, that to the best of my knowledge, the above-described waste material was managed in compliance with all applicable laws, regulations, permits and licenses on the date listed above.

Becky Sumner

CWMNW RECORDS DEPARTMENT

Date: 10/25/13



WASTE MANAGEMENT
17629 Cedar Springs Lane
Arlington, OR 97812

PORT OF TACOMA
WAD001882984
3400 TAYLOR WAY
TACOMA WA 98421

CERTIFICATE OF DISPOSAL

Chemical Waste Management of the Northwest, Inc., ORD089452353, has received the following waste material:

GENERATOR:	PORT OF TACOMA
MANIFEST #:	011886600JJK
CWM TRACKING ID:	429765-01
PROFILE #:	OR321468
LINE ITEM:	9b.1
QUANTITY:	1 DT
RECEIVED DATE:	10/23/13
DISPOSAL PROCESS(ES):	LANDFILL
FINAL DISPOSAL LOCATION:	LANDFILL 13
DISPOSAL DATE:	10/23/13

I certify, on behalf of the above listed treatment facility, that to the best of my knowledge, the above-described waste material was managed in compliance with all applicable laws, regulations, permits and licenses on the date listed above.

Becky Sumner

CWMNW RECORDS DEPARTMENT

Date: 10/25/13



WASTE MANAGEMENT
17629 Cedar Springs Lane
Arlington, OR 97812

PORT OF TACOMA
WAD001882984
3400 TAYLOR WAY
TACOMA WA 98421

CERTIFICATE OF DISPOSAL

Chemical Waste Management of the Northwest, Inc., ORD089452353, has received the following waste material:

GENERATOR:	PORT OF TACOMA
MANIFEST #:	011886991JJK
CWM TRACKING ID:	429769-01
PROFILE #:	OR321468
LINE ITEM:	9b.1
QUANTITY:	1 DT
RECEIVED DATE:	10/23/13
DISPOSAL PROCESS(ES):	LANDFILL
FINAL DISPOSAL LOCATION:	LANDFILL 13
DISPOSAL DATE:	10/23/13

I certify, on behalf of the above listed treatment facility, that to the best of my knowledge, the above-described waste material was managed in compliance with all applicable laws, regulations, permits and licenses on the date listed above.

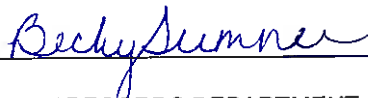

CWMNW RECORDS DEPARTMENT

Date: 10/25/13



WASTE MANAGEMENT
17629 Cedar Springs Lane
Arlington, OR 97812

PORT OF TACOMA
WAD001882984
3400 TAYLOR WAY
TACOMA WA 98421

CERTIFICATE OF DISPOSAL

Chemical Waste Management of the Northwest, Inc., ORD089452353, has received the following waste material:

GENERATOR:	PORT OF TACOMA
MANIFEST #:	011886989JJK
CWM TRACKING ID:	429772-01
PROFILE #:	OR321468
LINE ITEM:	9b.1
QUANTITY:	1 DT
RECEIVED DATE:	10/23/13
DISPOSAL PROCESS(ES):	LANDFILL
FINAL DISPOSAL LOCATION:	LANDFILL 13
DISPOSAL DATE:	10/23/13

I certify, on behalf of the above listed treatment facility, that to the best of my knowledge, the above-described waste material was managed in compliance with all applicable laws, regulations, permits and licenses on the date listed above.

Becky Sumner

CWMNW RECORDS DEPARTMENT
Date: 10/25/13



WASTE MANAGEMENT
17629 Cedar Springs Lane
Arlington, OR 97812

PORT OF TACOMA
WAD001882984
3400 TAYLOR WAY
TACOMA WA 98421

CERTIFICATE OF DISPOSAL

Chemical Waste Management of the Northwest, Inc., ORD089452353, has received the following waste material:

GENERATOR:	PORT OF TACOMA
MANIFEST #:	011886599JJK
CWM TRACKING ID:	429775-01
PROFILE #:	OR321468
LINE ITEM:	9b.1
QUANTITY:	1 DT
RECEIVED DATE:	10/23/13
DISPOSAL PROCESS(ES):	LANDFILL
FINAL DISPOSAL LOCATION:	LANDFILL 13
DISPOSAL DATE:	10/23/13

I certify, on behalf of the above listed treatment facility, that to the best of my knowledge, the above-described waste material was managed in compliance with all applicable laws, regulations, permits and licenses on the date listed above.

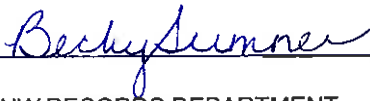

CWMNW RECORDS DEPARTMENT
Date:

10/25/13



WASTE MANAGEMENT
17629 Cedar Springs Lane
Arlington, OR 97812

PORT OF TACOMA
WAD001882984
3400 TAYLOR WAY
TACOMA WA 98421

CERTIFICATE OF DISPOSAL

Chemical Waste Management of the Northwest, Inc., ORD089452353, has received the following waste material:

GENERATOR:	PORT OF TACOMA
MANIFEST #:	011886990JJK
CWM TRACKING ID:	429776-01
PROFILE #:	OR321468
LINE ITEM:	9b.1
QUANTITY:	1 DT
RECEIVED DATE:	10/23/13
DISPOSAL PROCESS(ES):	LANDFILL
FINAL DISPOSAL LOCATION:	LANDFILL 13
DISPOSAL DATE:	10/23/13

I certify, on behalf of the above listed treatment facility, that to the best of my knowledge, the above-described waste material was managed in compliance with all applicable laws, regulations, permits and licenses on the date listed above.

Becky Sumner

CWMNW RECORDS DEPARTMENT
Date: 10/25/13



WASTE MANAGEMENT
17629 Cedar Springs Lane
Arlington, OR 97812

PORT OF TACOMA
WAD001882984
3400 TAYLOR WAY
TACOMA WA 98421

CERTIFICATE OF DISPOSAL

Chemical Waste Management of the Northwest, Inc., ORD089452353, has received the following waste material:

GENERATOR:	PORT OF TACOMA
MANIFEST #:	011886603JJK
CWM TRACKING ID:	429782-01
PROFILE #:	OR321468
LINE ITEM:	9b.1
QUANTITY:	1 DT
RECEIVED DATE:	10/23/13
DISPOSAL PROCESS(ES):	LANDFILL
FINAL DISPOSAL LOCATION:	LANDFILL 13
DISPOSAL DATE:	10/23/13

I certify, on behalf of the above listed treatment facility, that to the best of my knowledge, the above-described waste material was managed in compliance with all applicable laws, regulations, permits and licenses on the date listed above.

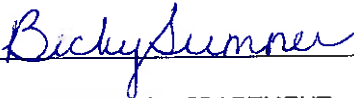

CWMNW RECORDS DEPARTMENT

Date: 10/25/13



WASTE MANAGEMENT
17629 Cedar Springs Lane
Arlington, OR 97812

PORT OF TACOMA
WAD001882984
3400 TAYLOR WAY
TACOMA WA 98421

CERTIFICATE OF DISPOSAL

Chemical Waste Management of the Northwest, Inc., ORD089452353, has received the following waste material:

GENERATOR:	PORT OF TACOMA
MANIFEST #:	011886602JJK
CWM TRACKING ID:	429788-01
PROFILE #:	OR321468
LINE ITEM:	9b.1
QUANTITY:	1 DT
RECEIVED DATE:	10/23/13
DISPOSAL PROCESS(ES):	LANDFILL
FINAL DISPOSAL LOCATION:	LANDFILL 13
DISPOSAL DATE:	10/23/13

I certify, on behalf of the above listed treatment facility, that to the best of my knowledge, the above-described waste material was managed in compliance with all applicable laws, regulations, permits and licenses on the date listed above.

Becky Sumner

CWMNW RECORDS DEPARTMENT
Date: 10/25/13



WASTE MANAGEMENT
17629 Cedar Springs Lane
Arlington, OR 97812

PORT OF TACOMA
WAD001882984
3400 TAYLOR WAY
TACOMA WA 98421

CERTIFICATE OF DISPOSAL

Chemical Waste Management of the Northwest, Inc., ORD089452353, has received the following waste material:

GENERATOR:	PORT OF TACOMA
MANIFEST #:	011886606JJK
CWM TRACKING ID:	429801-01
PROFILE #:	OR321468
LINE ITEM:	9b.1
QUANTITY:	1 DT
RECEIVED DATE:	10/24/13
DISPOSAL PROCESS(ES):	LANDFILL
FINAL DISPOSAL LOCATION:	LANDFILL 13
DISPOSAL DATE:	10/24/13

I certify, on behalf of the above listed treatment facility, that to the best of my knowledge, the above-described waste material was managed in compliance with all applicable laws, regulations, permits and licenses on the date listed above.

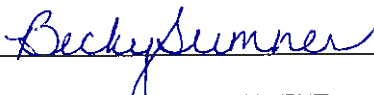

CWMNW RECORDS DEPARTMENT

Date: 10/29/13



WASTE MANAGEMENT
 17629 Cedar Springs Lane
 Arlington, OR 97812

PORT OF TACOMA
 WAD001882984
 3400 TAYLOR WAY
 TACOMA WA 98421

CERTIFICATE OF DISPOSAL

Chemical Waste Management of the Northwest, Inc., ORD089452353, has received the following waste material:

GENERATOR:	PORT OF TACOMA	
MANIFEST #:	011886984JJJ	
CWM TRACKING ID:	429835-01	
PROFILE #:	OR321468	
LINE ITEM:	9b.1	
QUANTITY:	1 DT	
RECEIVED DATE:	10/24/13	
DISPOSAL PROCESS(ES):	LANDFILL	
FINAL DISPOSAL LOCATION:	LANDFILL	13
DISPOSAL DATE:	10/24/13	

I certify, on behalf of the above listed treatment facility, that to the best of my knowledge, the above-described waste material was managed in compliance with all applicable laws, regulations, permits and licenses on the date listed above.

Becky Sumner

CWMNW RECORDS DEPARTMENT
 Date: 10/29/13



WASTE MANAGEMENT
17629 Cedar Springs Lane
Arlington, OR 97812

PORT OF TACOMA
WAD001882984
3400 TAYLOR WAY
TACOMA WA 98421

CERTIFICATE OF DISPOSAL

Chemical Waste Management of the Northwest, Inc., ORD089452353, has received the following waste material:

GENERATOR:	PORT OF TACOMA	
MANIFEST #:	011886985JJK	
CWM TRACKING ID:	429836-01	
PROFILE #:	OR321468	
LINE ITEM:	9b.1	
QUANTITY:	1 DT	
RECEIVED DATE:	10/24/13	
DISPOSAL PROCESS(ES):	LANDFILL	
FINAL DISPOSAL LOCATION:	LANDFILL	13
DISPOSAL DATE:	10/24/13	

I certify, on behalf of the above listed treatment facility, that to the best of my knowledge, the above-described waste material was managed in compliance with all applicable laws, regulations, permits and licenses on the date listed above.

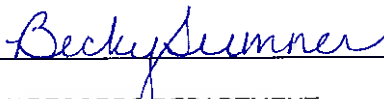

CWMNW RECORDS DEPARTMENT

Date: 10/29/13



WASTE MANAGEMENT
17629 Cedar Springs Lane
Arlington, OR 97812

PORT OF TACOMA
WAD001882984
3400 TAYLOR WAY
TACOMA WA 98421

CERTIFICATE OF DISPOSAL

Chemical Waste Management of the Northwest, Inc., ORD089452353, has received the following waste material:

GENERATOR:	PORT OF TACOMA	
MANIFEST #:	011886988JJK	
CWM TRACKING ID:	429840-01	
PROFILE #:	OR321468	
LINE ITEM:	9b.1	
QUANTITY:	1 DT	
RECEIVED DATE:	10/24/13	
DISPOSAL PROCESS(ES):	LANDFILL	
FINAL DISPOSAL LOCATION:	LANDFILL	13
DISPOSAL DATE:	10/24/13	

I certify, on behalf of the above listed treatment facility, that to the best of my knowledge, the above-described waste material was managed in compliance with all applicable laws, regulations, permits and licenses on the date listed above.

Becky Sumner

CWMNW RECORDS DEPARTMENT

Date: 10/29/13



WASTE MANAGEMENT
17629 Cedar Springs Lane
Arlington, OR 97812

PORT OF TACOMA
WAD001882984
3400 TAYLOR WAY
TACOMA WA 98421

CERTIFICATE OF DISPOSAL

Chemical Waste Management of the Northwest, Inc., ORD089452353, has received the following waste material:

GENERATOR:	PORT OF TACOMA
MANIFEST #:	011886983JJK
CWM TRACKING ID:	429845-01
PROFILE #:	OR321468
LINE ITEM:	9b.1
QUANTITY:	1 DT
RECEIVED DATE:	10/24/13
DISPOSAL PROCESS(ES):	LANDFILL
FINAL DISPOSAL LOCATION:	LANDFILL 13
DISPOSAL DATE:	10/24/13

I certify, on behalf of the above listed treatment facility, that to the best of my knowledge, the above-described waste material was managed in compliance with all applicable laws, regulations, permits and licenses on the date listed above.

Becky Sumner

CWMNW RECORDS DEPARTMENT
Date: 10/29/13



WASTE MANAGEMENT
17629 Cedar Springs Lane
Arlington, OR 97812

PORT OF TACOMA
WAD001882984
3400 TAYLOR WAY
TACOMA WA 98421

CERTIFICATE OF DISPOSAL

Chemical Waste Management of the Northwest, Inc., ORD089452353, has received the following waste material:

GENERATOR:	PORT OF TACOMA	
MANIFEST #:	011886981JJK	
CWM TRACKING ID:	429846-01	
PROFILE #:	OR321468	
LINE ITEM:	9b.1	
QUANTITY:	1 DT	
RECEIVED DATE:	10/24/13	
DISPOSAL PROCESS(ES):	LANDFILL	
FINAL DISPOSAL LOCATION:	LANDFILL	13
DISPOSAL DATE:	10/24/13	

I certify, on behalf of the above listed treatment facility, that to the best of my knowledge, the above-described waste material was managed in compliance with all applicable laws, regulations, permits and licenses on the date listed above.

Becky Sumner

CWMNW RECORDS DEPARTMENT

Date: 10/29/13



WASTE MANAGEMENT
17629 Cedar Springs Lane
Arlington, OR 97812

PORT OF TACOMA
WAD001882984
3400 TAYLOR WAY
TACOMA WA 98421

CERTIFICATE OF DISPOSAL

Chemical Waste Management of the Northwest, Inc., ORD089452353, has received the following waste material:

GENERATOR:	PORT OF TACOMA
MANIFEST #:	011886987JJK
CWM TRACKING ID:	429847-01
PROFILE #:	OR321468
LINE ITEM:	9b.1
QUANTITY:	1 DT
RECEIVED DATE:	10/24/13
DISPOSAL PROCESS(ES):	LANDFILL
FINAL DISPOSAL LOCATION:	LANDFILL 13
DISPOSAL DATE:	10/24/13

I certify, on behalf of the above listed treatment facility, that to the best of my knowledge, the above-described waste material was managed in compliance with all applicable laws, regulations, permits and licenses on the date listed above.

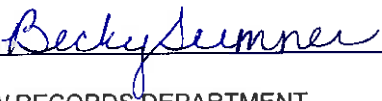

CWMNW RECORDS DEPARTMENT
Date: 10/29/13



WASTE MANAGEMENT
17629 Cedar Springs Lane
Arlington, OR 97812

PORT OF TACOMA
WAD001882984
3400 TAYLOR WAY
TACOMA WA 98421

CERTIFICATE OF DISPOSAL

Chemical Waste Management of the Northwest, Inc., ORD089452353, has received the following waste material:

GENERATOR:	PORT OF TACOMA
MANIFEST #:	011886982JJK
CWM TRACKING ID:	429848-01
PROFILE #:	OR321468
LINE ITEM:	9b.1
QUANTITY:	1 DT
RECEIVED DATE:	10/24/13
DISPOSAL PROCESS(ES):	LANDFILL
FINAL DISPOSAL LOCATION:	LANDFILL 13
DISPOSAL DATE:	10/24/13

I certify, on behalf of the above listed treatment facility, that to the best of my knowledge, the above-described waste material was managed in compliance with all applicable laws, regulations, permits and licenses on the date listed above.

Becky Sumner

CWMNW RECORDS DEPARTMENT

Date: 10/29/13



WASTE MANAGEMENT
17629 Cedar Springs Lane
Arlington, OR 97812

PORT OF TACOMA
WAD001882984
3400 TAYLOR WAY
TACOMA WA 98421

CERTIFICATE OF DISPOSAL

Chemical Waste Management of the Northwest, Inc., ORD089452353, has received the following waste material:

GENERATOR:	PORT OF TACOMA
MANIFEST #:	011886986JJK
CWM TRACKING ID:	429857-01
PROFILE #:	OR321468
LINE ITEM:	9b.1
QUANTITY:	1 DT
RECEIVED DATE:	10/24/13
DISPOSAL PROCESS(ES):	LANDFILL
FINAL DISPOSAL LOCATION:	LANDFILL 13
DISPOSAL DATE:	10/24/13

I certify, on behalf of the above listed treatment facility, that to the best of my knowledge, the above-described waste material was managed in compliance with all applicable laws, regulations, permits and licenses on the date listed above.

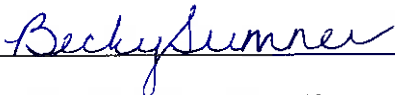

CWMNW RECORDS DEPARTMENT

Date: 10/29/13



WASTE MANAGEMENT
17629 Cedar Springs Lane
Arlington, OR 97812

PORT OF TACOMA
WAD001882984
3400 TAYLOR WAY
TACOMA WA 98421

CERTIFICATE OF DISPOSAL

Chemical Waste Management of the Northwest, Inc., ORD089452353, has received the following waste material:

GENERATOR:	PORT OF TACOMA
MANIFEST #:	011886874JJK
CWM TRACKING ID:	429858-01
PROFILE #:	OR321468
LINE ITEM:	9b.1
QUANTITY:	1 DT
RECEIVED DATE:	10/24/13
DISPOSAL PROCESS(ES):	LANDFILL
FINAL DISPOSAL LOCATION:	LANDFILL 13
DISPOSAL DATE:	10/24/13

I certify, on behalf of the above listed treatment facility, that to the best of my knowledge, the above-described waste material was managed in compliance with all applicable laws, regulations, permits and licenses on the date listed above.

Becky Sumner

CWMNW RECORDS DEPARTMENT

Date: 10/29/13



WASTE MANAGEMENT
17629 Cedar Springs Lane
Arlington, OR 97812

PORT OF TACOMA
WAD001882984
3400 TAYLOR WAY
TACOMA WA 98421

CERTIFICATE OF DISPOSAL

Chemical Waste Management of the Northwest, Inc., ORD089452353, has received the following waste material:

GENERATOR:	PORT OF TACOMA
MANIFEST #:	011886975JJK
CWM TRACKING ID:	429875-01
PROFILE #:	OR321468
LINE ITEM:	9b.1
QUANTITY:	1 DT
RECEIVED DATE:	10/25/13
DISPOSAL PROCESS(ES):	LANDFILL
FINAL DISPOSAL LOCATION:	LANDFILL 13
DISPOSAL DATE:	10/25/13

I certify, on behalf of the above listed treatment facility, that to the best of my knowledge, the above-described waste material was managed in compliance with all applicable laws, regulations, permits and licenses on the date listed above.

Becky Sumner

CWMNW RECORDS DEPARTMENT

Date: 10/30/13



WASTE MANAGEMENT
17629 Cedar Springs Lane
Arlington, OR 97812

PORT OF TACOMA
WAD001882984
3400 TAYLOR WAY
TACOMA WA 98421

CERTIFICATE OF DISPOSAL

Chemical Waste Management of the Northwest, Inc., ORD089452353, has received the following waste material:

GENERATOR:	PORT OF TACOMA
MANIFEST #:	011886979JJK
CWM TRACKING ID:	429897-01
PROFILE #:	OR321468
LINE ITEM:	9b.1
QUANTITY:	1 DT
RECEIVED DATE:	10/25/13
DISPOSAL PROCESS(ES):	LANDFILL
FINAL DISPOSAL LOCATION:	LANDFILL 13
DISPOSAL DATE:	10/25/13

I certify, on behalf of the above listed treatment facility, that to the best of my knowledge, the above-described waste material was managed in compliance with all applicable laws, regulations, permits and licenses on the date listed above.

Becky Sumner

_____ CWMNW RECORDS DEPARTMENT

Date: 10/30/13



WASTE MANAGEMENT
17629 Cedar Springs Lane
Arlington, OR 97812

PORT OF TACOMA
WAD001882984
3400 TAYLOR WAY
TACOMA WA 98421

CERTIFICATE OF DISPOSAL

Chemical Waste Management of the Northwest, Inc., ORD089452353, has received the following waste material:

GENERATOR:	PORT OF TACOMA
MANIFEST #:	011886980JJK
CWM TRACKING ID:	429898-01
PROFILE #:	OR321468
LINE ITEM:	9b.1
QUANTITY:	1 DT
RECEIVED DATE:	10/25/13
DISPOSAL PROCESS(ES):	LANDFILL
FINAL DISPOSAL LOCATION:	LANDFILL 13
DISPOSAL DATE:	10/25/13

I certify, on behalf of the above listed treatment facility, that to the best of my knowledge, the above-described waste material was managed in compliance with all applicable laws, regulations, permits and licenses on the date listed above.

Bucky Sumner

_____ CWMNW RECORDS DEPARTMENT

Date: 10/30/13



WASTE MANAGEMENT
17629 Cedar Springs Lane
Arlington, OR 97812

PORT OF TACOMA
WAD001882984
3400 TAYLOR WAY
TACOMA WA 98421

CERTIFICATE OF DISPOSAL

Chemical Waste Management of the Northwest, Inc., ORD089452353, has received the following waste material:

GENERATOR:	PORT OF TACOMA
MANIFEST #:	011886967JJK
CWM TRACKING ID:	429899-01
PROFILE #:	OR321468
LINE ITEM:	9b.1
QUANTITY:	1 DT
RECEIVED DATE:	10/25/13
DISPOSAL PROCESS(ES):	LANDFILL
FINAL DISPOSAL LOCATION:	LANDFILL 13
DISPOSAL DATE:	10/25/13

I certify, on behalf of the above listed treatment facility, that to the best of my knowledge, the above-described waste material was managed in compliance with all applicable laws, regulations, permits and licenses on the date listed above.

Becky Sumner

CWMNW RECORDS DEPARTMENT

Date: 10/30/13



WASTE MANAGEMENT
17629 Cedar Springs Lane
Arlington, OR 97812

PORT OF TACOMA
WAD001882984
3400 TAYLOR WAY
TACOMA WA 98421

CERTIFICATE OF DISPOSAL

Chemical Waste Management of the Northwest, Inc., ORD089452353, has received the following waste material:

GENERATOR:	PORT OF TACOMA
MANIFEST #:	011886966JJK
CWM TRACKING ID:	429901-01
PROFILE #:	OR321468
LINE ITEM:	9b.1
QUANTITY:	1 DT
RECEIVED DATE:	10/25/13
DISPOSAL PROCESS(ES):	LANDFILL
FINAL DISPOSAL LOCATION:	LANDFILL 13
DISPOSAL DATE:	10/25/13

I certify, on behalf of the above listed treatment facility, that to the best of my knowledge, the above-described waste material was managed in compliance with all applicable laws, regulations, permits and licenses on the date listed above.

Becky Sumner

CWMNW RECORDS DEPARTMENT

Date: 10/30/13



WASTE MANAGEMENT
17629 Cedar Springs Lane
Arlington, OR 97812

PORT OF TACOMA
WAD001882984
3400 TAYLOR WAY
TACOMA WA 98421

CERTIFICATE OF DISPOSAL

Chemical Waste Management of the Northwest, Inc., ORD089452353, has received the following waste material:

GENERATOR:	PORT OF TACOMA
MANIFEST #:	011886970JJK
CWM TRACKING ID:	429903-01
PROFILE #:	OR321468
LINE ITEM:	9b.1
QUANTITY:	1 DT
RECEIVED DATE:	10/25/13
DISPOSAL PROCESS(ES):	LANDFILL
FINAL DISPOSAL LOCATION:	LANDFILL 13
DISPOSAL DATE:	10/25/13

I certify, on behalf of the above listed treatment facility, that to the best of my knowledge, the above-described waste material was managed in compliance with all applicable laws, regulations, permits and licenses on the date listed above.

Becky Sumner

CWMNW RECORDS DEPARTMENT

Date: 10/30/13



WASTE MANAGEMENT
17629 Cedar Springs Lane
Arlington, OR 97812

PORT OF TACOMA
WAD001882984
3400 TAYLOR WAY
TACOMA WA 98421

CERTIFICATE OF DISPOSAL

Chemical Waste Management of the Northwest, Inc., ORD089452353, has received the following waste material:

GENERATOR:	PORT OF TACOMA
MANIFEST #:	011886977JJK
CWM TRACKING ID:	429904-01
PROFILE #:	OR321468
LINE ITEM:	9b.1
QUANTITY:	1 DT
RECEIVED DATE:	10/25/13
DISPOSAL PROCESS(ES):	LANDFILL
FINAL DISPOSAL LOCATION:	LANDFILL 13
DISPOSAL DATE:	10/25/13

I certify, on behalf of the above listed treatment facility, that to the best of my knowledge, the above-described waste material was managed in compliance with all applicable laws, regulations, permits and licenses on the date listed above.

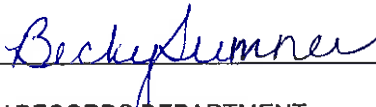

CWMNW RECORDS DEPARTMENT

Date: 10/30/13



WASTE MANAGEMENT
17629 Cedar Springs Lane
Arlington, OR 97812

PORT OF TACOMA
WAD001882984
3400 TAYLOR WAY
TACOMA WA 98421

CERTIFICATE OF DISPOSAL

Chemical Waste Management of the Northwest, Inc., ORD089452353, has received the following waste material:

GENERATOR:	PORT OF TACOMA
MANIFEST #:	011886968JJK
CWM TRACKING ID:	429905-01
PROFILE #:	OR321468
LINE ITEM:	9b.1
QUANTITY:	1 DT
RECEIVED DATE:	10/25/13
DISPOSAL PROCESS(ES):	LANDFILL
FINAL DISPOSAL LOCATION:	LANDFILL 13
DISPOSAL DATE:	10/25/13

I certify, on behalf of the above listed treatment facility, that to the best of my knowledge, the above-described waste material was managed in compliance with all applicable laws, regulations, permits and licenses on the date listed above.

Becky Sumner

CWMNW RECORDS DEPARTMENT

Date: 10/30/13



WASTE MANAGEMENT
17629 Cedar Springs Lane
Arlington, OR 97812

PORT OF TACOMA
WAD001882984
3400 TAYLOR WAY
TACOMA WA 98421

CERTIFICATE OF DISPOSAL

Chemical Waste Management of the Northwest, Inc., ORD089452353, has received the following waste material:

GENERATOR:	PORT OF TACOMA
MANIFEST #:	011886976JJK
CWM TRACKING ID:	429909-01
PROFILE #:	OR321468
LINE ITEM:	9b.1
QUANTITY:	1 DT
RECEIVED DATE:	10/25/13
DISPOSAL PROCESS(ES):	LANDFILL
FINAL DISPOSAL LOCATION:	LANDFILL 13
DISPOSAL DATE:	10/25/13

I certify, on behalf of the above listed treatment facility, that to the best of my knowledge, the above-described waste material was managed in compliance with all applicable laws, regulations, permits and licenses on the date listed above.



CWMNW RECORDS DEPARTMENT

Date: 10/30/13



WASTE MANAGEMENT
17629 Cedar Springs Lane
Arlington, OR 97812

PORT OF TACOMA
WAD001882984
3400 TAYLOR WAY
TACOMA WA 98421

CERTIFICATE OF DISPOSAL

Chemical Waste Management of the Northwest, Inc., ORD089452353, has received the following waste material:

GENERATOR:	PORT OF TACOMA
MANIFEST #:	011886978JJK
CWM TRACKING ID:	429906-01
PROFILE #:	OR321468
LINE ITEM:	9b.1
QUANTITY:	1 DT
RECEIVED DATE:	10/25/13
DISPOSAL PROCESS(ES):	LANDFILL
FINAL DISPOSAL LOCATION:	LANDFILL 13
DISPOSAL DATE:	10/25/13

I certify, on behalf of the above listed treatment facility, that to the best of my knowledge, the above-described waste material was managed in compliance with all applicable laws, regulations, permits and licenses on the date listed above.

Becky Sumner

CWMNW RECORDS DEPARTMENT

Date: 10/30/13



WASTE MANAGEMENT
17629 Cedar Springs Lane
Arlington, OR 97812

PORT OF TACOMA
WAD001882984
3400 TAYLOR WAY
TACOMA WA 98421

CERTIFICATE OF DISPOSAL

Chemical Waste Management of the Northwest, Inc., ORD089452353, has received the following waste material:

GENERATOR:	PORT OF TACOMA
MANIFEST #:	011886969JJK
CWM TRACKING ID:	429911-01
PROFILE #:	OR321468
LINE ITEM:	9b.1
QUANTITY:	1 DT
RECEIVED DATE:	10/25/13
DISPOSAL PROCESS(ES):	LANDFILL
FINAL DISPOSAL LOCATION:	LANDFILL 13
DISPOSAL DATE:	10/25/13

I certify, on behalf of the above listed treatment facility, that to the best of my knowledge, the above-described waste material was managed in compliance with all applicable laws, regulations, permits and licenses on the date listed above.

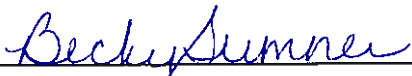

CWMNW RECORDS DEPARTMENT

Date: 10/30/13



WASTE MANAGEMENT
17629 Cedar Springs Lane
Arlington, OR 97812

PORT OF TACOMA
WAD001882984
3400 TAYLOR WAY
TACOMA WA 98421

CERTIFICATE OF DISPOSAL

Chemical Waste Management of the Northwest, Inc., ORD089452353, has received the following waste material:

GENERATOR:	PORT OF TACOMA
MANIFEST #:	011886971JJK
CWM TRACKING ID:	429912-01
PROFILE #:	OR321468
LINE ITEM:	9b.1
QUANTITY:	1 DT
RECEIVED DATE:	10/25/13
DISPOSAL PROCESS(ES):	LANDFILL
FINAL DISPOSAL LOCATION:	LANDFILL 13
DISPOSAL DATE:	10/25/13

I certify, on behalf of the above listed treatment facility, that to the best of my knowledge, the above-described waste material was managed in compliance with all applicable laws, regulations, permits and licenses on the date listed above.

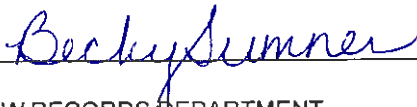

CWMNW RECORDS DEPARTMENT

Date: 10/30/13



WASTE MANAGEMENT
17629 Cedar Springs Lane
Arlington, OR 97812

PORT OF TACOMA
WAD001882984
3400 TAYLOR WAY
TACOMA WA 98421

CERTIFICATE OF DISPOSAL

Chemical Waste Management of the Northwest, Inc., ORD089452353, has received the following waste material:

GENERATOR:	PORT OF TACOMA
MANIFEST #:	011886973JJK
CWM TRACKING ID:	429927-01
PROFILE #:	OR321468
LINE ITEM:	9b.1
QUANTITY:	1 DT
RECEIVED DATE:	10/25/13
DISPOSAL PROCESS(ES):	LANDFILL
FINAL DISPOSAL LOCATION:	LANDFILL 13
DISPOSAL DATE:	10/25/13

I certify, on behalf of the above listed treatment facility, that to the best of my knowledge, the above-described waste material was managed in compliance with all applicable laws, regulations, permits and licenses on the date listed above.

Becky Sumner

CWMNW RECORDS DEPARTMENT

Date: 10/30/13



WASTE MANAGEMENT
17629 Cedar Springs Lane
Arlington, OR 97812

PORT OF TACOMA
WAD001882984
3400 TAYLOR WAY
TACOMA WA 98421

CERTIFICATE OF DISPOSAL

Chemical Waste Management of the Northwest, Inc., ORD089452353, has received the following waste material:

GENERATOR:	PORT OF TACOMA
MANIFEST #:	011886965JJK
CWM TRACKING ID:	429965-01
PROFILE #:	OR321468
LINE ITEM:	9b.1
QUANTITY:	1 DT
RECEIVED DATE:	10/28/13
DISPOSAL PROCESS(ES):	LANDFILL
FINAL DISPOSAL LOCATION:	LANDFILL 13
DISPOSAL DATE:	10/28/13

I certify, on behalf of the above listed treatment facility, that to the best of my knowledge, the above-described waste material was managed in compliance with all applicable laws, regulations, permits and licenses on the date listed above.



CWMNW RECORDS DEPARTMENT

Date: 10/30/13



WASTE MANAGEMENT
17629 Cedar Springs Lane
Arlington, OR 97812

PORT OF TACOMA
WAD001882984
3400 TAYLOR WAY
TACOMA WA 98421

CERTIFICATE OF DISPOSAL

Chemical Waste Management of the Northwest, Inc., ORD089452353, has received the following waste material:

GENERATOR:	PORT OF TACOMA
MANIFEST #:	011886962JJK
CWM TRACKING ID:	429968-01
PROFILE #:	OR321468
LINE ITEM:	9b.1
QUANTITY:	1 DT
RECEIVED DATE:	10/28/13
DISPOSAL PROCESS(ES):	LANDFILL
FINAL DISPOSAL LOCATION:	LANDFILL 13
DISPOSAL DATE:	10/28/13

I certify, on behalf of the above listed treatment facility, that to the best of my knowledge, the above-described waste material was managed in compliance with all applicable laws, regulations, permits and licenses on the date listed above.

Becky Sumner

CWMNW RECORDS DEPARTMENT

Date: 10/30/13



WASTE MANAGEMENT

17629 Cedar Springs Lane
Arlington, OR 97812

PORT OF TACOMA
WAD001882984
3400 TAYLOR WAY
TACOMA WA 98421

CERTIFICATE OF DISPOSAL

Chemical Waste Management of the Northwest, Inc., ORD089452353, has received the following waste material:

GENERATOR:	PORT OF TACOMA
MANIFEST #:	011886963JJK
CWM TRACKING ID:	429970-01
PROFILE #:	OR321468
LINE ITEM:	9b.1
QUANTITY:	1 DT
RECEIVED DATE:	10/28/13
DISPOSAL PROCESS(ES):	LANDFILL
FINAL DISPOSAL LOCATION:	LANDFILL 13
DISPOSAL DATE:	10/28/13

I certify, on behalf of the above listed treatment facility, that to the best of my knowledge, the above-described waste material was managed in compliance with all applicable laws, regulations, permits and licenses on the date listed above.

Becky Sumner

CWMNW RECORDS DEPARTMENT

Date: 10/30/13



WASTE MANAGEMENT
17629 Cedar Springs Lane
Arlington, OR 97812

PORT OF TACOMA
WAD001882984
3400 TAYLOR WAY
TACOMA WA 98421

CERTIFICATE OF DISPOSAL

Chemical Waste Management of the Northwest, Inc., ORD089452353, has received the following waste material:

GENERATOR:	PORT OF TACOMA
MANIFEST #:	011886961JJK
CWM TRACKING ID:	429972-01
PROFILE #:	OR321468
LINE ITEM:	9b.1
QUANTITY:	1 DT
RECEIVED DATE:	10/28/13
DISPOSAL PROCESS(ES):	LANDFILL
FINAL DISPOSAL LOCATION:	LANDFILL 13
DISPOSAL DATE:	10/28/13

I certify, on behalf of the above listed treatment facility, that to the best of my knowledge, the above-described waste material was managed in compliance with all applicable laws, regulations, permits and licenses on the date listed above.

Becky Sumner

_____ CWMNW RECORDS DEPARTMENT

Date: 10/30/13



WASTE MANAGEMENT
17629 Cedar Springs Lane
Arlington, OR 97812

PORT OF TACOMA
WAD001882984
3400 TAYLOR WAY
TACOMA WA 98421

CERTIFICATE OF DISPOSAL

Chemical Waste Management of the Northwest, Inc., ORD089452353, has received the following waste material:

GENERATOR:	PORT OF TACOMA
MANIFEST #:	011886960JJK
CWM TRACKING ID:	429973-01
PROFILE #:	OR321468
LINE ITEM:	9b.1
QUANTITY:	1 DT
RECEIVED DATE:	10/28/13
DISPOSAL PROCESS(ES):	LANDFILL
FINAL DISPOSAL LOCATION:	LANDFILL 13
DISPOSAL DATE:	10/28/13

I certify, on behalf of the above listed treatment facility, that to the best of my knowledge, the above-described waste material was managed in compliance with all applicable laws, regulations, permits and licenses on the date listed above.

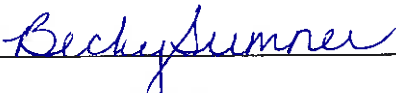

CWMNW RECORDS DEPARTMENT

Date: 10/30/13



WASTE MANAGEMENT
17629 Cedar Springs Lane
Arlington, OR 97812

PORT OF TACOMA
WAD001882984
3400 TAYLOR WAY
TACOMA WA 98421

CERTIFICATE OF DISPOSAL

Chemical Waste Management of the Northwest, Inc., ORD089452353, has received the following waste material:

GENERATOR:	PORT OF TACOMA
MANIFEST #:	011886972JJK
CWM TRACKING ID:	429975-01
PROFILE #:	OR321468
LINE ITEM:	9b.1
QUANTITY:	1 DT
RECEIVED DATE:	10/28/13
DISPOSAL PROCESS(ES):	LANDFILL
FINAL DISPOSAL LOCATION:	LANDFILL 13
DISPOSAL DATE:	10/28/13

I certify, on behalf of the above listed treatment facility, that to the best of my knowledge, the above-described waste material was managed in compliance with all applicable laws, regulations, permits and licenses on the date listed above.

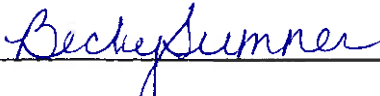

CWMNW RECORDS DEPARTMENT

Date: 10/30/13



WASTE MANAGEMENT
17629 Cedar Springs Lane
Arlington, OR 97812

PORT OF TACOMA
WAD001882984
3400 TAYLOR WAY
TACOMA WA 98421

CERTIFICATE OF DISPOSAL

Chemical Waste Management of the Northwest, Inc., ORD089452353, has received the following waste material:

GENERATOR:	PORT OF TACOMA
MANIFEST #:	011886964JJK
CWM TRACKING ID:	429978-01
PROFILE #:	OR321468
LINE ITEM:	9b.1
QUANTITY:	1 DT
RECEIVED DATE:	10/28/13
DISPOSAL PROCESS(ES):	LANDFILL
FINAL DISPOSAL LOCATION:	LANDFILL 13
DISPOSAL DATE:	10/28/13

I certify, on behalf of the above listed treatment facility, that to the best of my knowledge, the above-described waste material was managed in compliance with all applicable laws, regulations, permits and licenses on the date listed above.

Becky Sumner

_____ CWMNW RECORDS DEPARTMENT

Date: 10/30/13



WASTE MANAGEMENT
17629 Cedar Springs Lane
Arlington, OR 97812

PORT OF TACOMA
WAD001882984
3400 TAYLOR WAY
TACOMA WA 98421

CERTIFICATE OF DISPOSAL

Chemical Waste Management of the Northwest, Inc., ORD089452353, has received the following waste material:

GENERATOR:	PORT OF TACOMA
MANIFEST #:	011886959JJK
CWM TRACKING ID:	429999-01
PROFILE #:	OR321468
LINE ITEM:	9b.1
QUANTITY:	1 DT
RECEIVED DATE:	10/29/13
DISPOSAL PROCESS(ES):	LANDFILL
FINAL DISPOSAL LOCATION:	LANDFILL 13
DISPOSAL DATE:	10/29/13

I certify, on behalf of the above listed treatment facility, that to the best of my knowledge, the above-described waste material was managed in compliance with all applicable laws, regulations, permits and licenses on the date listed above.

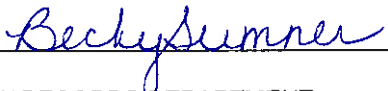

CWMNW RECORDS DEPARTMENT
Date: 10/31/13



WASTE MANAGEMENT
17629 Cedar Springs Lane
Arlington, OR 97812

PORT OF TACOMA
WAD001882984
3400 TAYLOR WAY
TACOMA WA 98421

CERTIFICATE OF DISPOSAL

Chemical Waste Management of the Northwest, Inc., ORD089452353, has received the following waste material:

GENERATOR:	PORT OF TACOMA
MANIFEST #:	011886957JJK
CWM TRACKING ID:	430022-01
PROFILE #:	OR321468
LINE ITEM:	9b.1
QUANTITY:	1 DT
RECEIVED DATE:	10/29/13
DISPOSAL PROCESS(ES):	LANDFILL
FINAL DISPOSAL LOCATION:	LANDFILL 13
DISPOSAL DATE:	10/29/13

I certify, on behalf of the above listed treatment facility, that to the best of my knowledge, the above-described waste material was managed in compliance with all applicable laws, regulations, permits and licenses on the date listed above.

Becky Sumner

CWMNW RECORDS DEPARTMENT

Date: 10/31/13



WASTE MANAGEMENT
17629 Cedar Springs Lane
Arlington, OR 97812

PORT OF TACOMA
WAD001882984
3400 TAYLOR WAY
TACOMA WA 98421

CERTIFICATE OF DISPOSAL

Chemical Waste Management of the Northwest, Inc., ORD089452353, has received the following waste material:

GENERATOR:	PORT OF TACOMA
MANIFEST #:	011886952JJK
CWM TRACKING ID:	430026-01
PROFILE #:	OR321468
LINE ITEM:	9b.1
QUANTITY:	1 DT
RECEIVED DATE:	10/29/13
DISPOSAL PROCESS(ES):	LANDFILL
FINAL DISPOSAL LOCATION:	LANDFILL 13
DISPOSAL DATE:	10/29/13

I certify, on behalf of the above listed treatment facility, that to the best of my knowledge, the above-described waste material was managed in compliance with all applicable laws, regulations, permits and licenses on the date listed above.

Becky Sumner

CWMNW RECORDS DEPARTMENT

Date: 10/31/13



WASTE MANAGEMENT
17629 Cedar Springs Lane
Arlington, OR 97812

PORT OF TACOMA
WAD001882984
3400 TAYLOR WAY
TACOMA WA 98421

CERTIFICATE OF DISPOSAL

Chemical Waste Management of the Northwest, Inc., ORD089452353, has received the following waste material:

GENERATOR:	PORT OF TACOMA
MANIFEST #:	011886954JJK
CWM TRACKING ID:	430027-01
PROFILE #:	OR321468
LINE ITEM:	9b.1
QUANTITY:	1 DT
RECEIVED DATE:	10/29/13
DISPOSAL PROCESS(ES):	LANDFILL
FINAL DISPOSAL LOCATION:	LANDFILL 13
DISPOSAL DATE:	10/29/13

I certify, on behalf of the above listed treatment facility, that to the best of my knowledge, the above-described waste material was managed in compliance with all applicable laws, regulations, permits and licenses on the date listed above.

Becky Sumner

CWMNW RECORDS DEPARTMENT

Date: 10/31/13



WASTE MANAGEMENT
17629 Cedar Springs Lane
Arlington, OR 97812

PORT OF TACOMA
WAD001882984
3400 TAYLOR WAY
TACOMA WA 98421

CERTIFICATE OF DISPOSAL

Chemical Waste Management of the Northwest, Inc., ORD089452353, has received the following waste material:

GENERATOR:	PORT OF TACOMA
MANIFEST #:	011886950JJK
CWM TRACKING ID:	430028-01
PROFILE #:	OR321468
LINE ITEM:	9b.1
QUANTITY:	1 DT
RECEIVED DATE:	10/29/13
DISPOSAL PROCESS(ES):	LANDFILL
FINAL DISPOSAL LOCATION:	LANDFILL 13
DISPOSAL DATE:	10/29/13

I certify, on behalf of the above listed treatment facility, that to the best of my knowledge, the above-described waste material was managed in compliance with all applicable laws, regulations, permits and licenses on the date listed above.

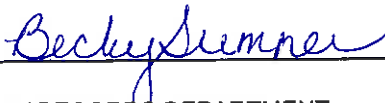

CWMNW RECORDS DEPARTMENT

Date: 10/31/13



WASTE MANAGEMENT
17629 Cedar Springs Lane
Arlington, OR 97812

PORT OF TACOMA
WAD001882984
3400 TAYLOR WAY
TACOMA WA 98421

CERTIFICATE OF DISPOSAL

Chemical Waste Management of the Northwest, Inc., ORD089452353, has received the following waste material:

GENERATOR:	PORT OF TACOMA
MANIFEST #:	011886943JJK
CWM TRACKING ID:	430029-01
PROFILE #:	OR321468
LINE ITEM:	9b.1
QUANTITY:	1 DT
RECEIVED DATE:	10/29/13
DISPOSAL PROCESS(ES):	LANDFILL
FINAL DISPOSAL LOCATION:	LANDFILL 13
DISPOSAL DATE:	10/29/13

I certify, on behalf of the above listed treatment facility, that to the best of my knowledge, the above-described waste material was managed in compliance with all applicable laws, regulations, permits and licenses on the date listed above.

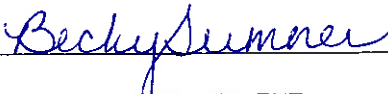

CWMNW RECORDS DEPARTMENT

Date: 10/31/13



WASTE MANAGEMENT
17629 Cedar Springs Lane
Arlington, OR 97812

PORT OF TACOMA
WAD001882984
3400 TAYLOR WAY
TACOMA WA 98421

CERTIFICATE OF DISPOSAL

Chemical Waste Management of the Northwest, Inc., ORD089452353, has received the following waste material:

GENERATOR:	PORT OF TACOMA	
MANIFEST #:	011886955JJK	
CWM TRACKING ID:	430030-01	
PROFILE #:	OR321468	
LINE ITEM:	9b.1	
QUANTITY:	1 DT	
RECEIVED DATE:	10/29/13	
DISPOSAL PROCESS(ES):	LANDFILL	
FINAL DISPOSAL LOCATION:	LANDFILL	13
DISPOSAL DATE:	10/29/13	

I certify, on behalf of the above listed treatment facility, that to the best of my knowledge, the above-described waste material was managed in compliance with all applicable laws, regulations, permits and licenses on the date listed above.



CWMNW RECORDS DEPARTMENT

Date: 10/31/13



WASTE MANAGEMENT
17629 Cedar Springs Lane
Arlington, OR 97812

PORT OF TACOMA
WAD001882984
3400 TAYLOR WAY
TACOMA WA 98421

CERTIFICATE OF DISPOSAL

Chemical Waste Management of the Northwest, Inc., ORD089452353, has received the following waste material:

GENERATOR:	PORT OF TACOMA
MANIFEST #:	011886949JJK
CWM TRACKING ID:	430031-01
PROFILE #:	OR321468
LINE ITEM:	9b.1
QUANTITY:	1 DT
RECEIVED DATE:	10/29/13
DISPOSAL PROCESS(ES):	LANDFILL
FINAL DISPOSAL LOCATION:	LANDFILL 13
DISPOSAL DATE:	10/29/13

I certify, on behalf of the above listed treatment facility, that to the best of my knowledge, the above-described waste material was managed in compliance with all applicable laws, regulations, permits and licenses on the date listed above.

Becky Sumner

CWMNW RECORDS DEPARTMENT

Date: 10/31/13



WASTE MANAGEMENT
17629 Cedar Springs Lane
Arlington, OR 97812

PORT OF TACOMA
WAD001882984
3400 TAYLOR WAY
TACOMA WA 98421

CERTIFICATE OF DISPOSAL

Chemical Waste Management of the Northwest, Inc., ORD089452353, has received the following waste material:

GENERATOR:	PORT OF TACOMA
MANIFEST #:	011886948JJK
CWM TRACKING ID:	430033-01
PROFILE #:	OR321468
LINE ITEM:	9b.1
QUANTITY:	1 DT
RECEIVED DATE:	10/29/13
DISPOSAL PROCESS(ES):	LANDFILL
FINAL DISPOSAL LOCATION:	LANDFILL 13
DISPOSAL DATE:	10/29/13

I certify, on behalf of the above listed treatment facility, that to the best of my knowledge, the above-described waste material was managed in compliance with all applicable laws, regulations, permits and licenses on the date listed above.

Becky Sumner

CWMNW RECORDS DEPARTMENT

Date: 10/31/13



WASTE MANAGEMENT
17629 Cedar Springs Lane
Arlington, OR 97812

PORT OF TACOMA
WAD001882984
3400 TAYLOR WAY
TACOMA WA 98421

CERTIFICATE OF DISPOSAL

Chemical Waste Management of the Northwest, Inc., ORD089452353, has received the following waste material:

GENERATOR:	PORT OF TACOMA
MANIFEST #:	011886944JJK
CWM TRACKING ID:	430037-01
PROFILE #:	OR321468
LINE ITEM:	9b.1
QUANTITY:	1 DT
RECEIVED DATE:	10/29/13
DISPOSAL PROCESS(ES):	LANDFILL
FINAL DISPOSAL LOCATION:	LANDFILL 13
DISPOSAL DATE:	10/29/13

I certify, on behalf of the above listed treatment facility, that to the best of my knowledge, the above-described waste material was managed in compliance with all applicable laws, regulations, permits and licenses on the date listed above.

Becky Sumner

CWMNW RECORDS DEPARTMENT

Date: 10/31/13



WASTE MANAGEMENT
17629 Cedar Springs Lane
Arlington, OR 97812

PORT OF TACOMA
WAD001882984
3400 TAYLOR WAY
TACOMA WA 98421

CERTIFICATE OF DISPOSAL

Chemical Waste Management of the Northwest, Inc., ORD089452353, has received the following waste material:

GENERATOR:	PORT OF TACOMA
MANIFEST #:	011886951JJK
CWM TRACKING ID:	430038-01
PROFILE #:	OR321468
LINE ITEM:	9b.1
QUANTITY:	1 DT
RECEIVED DATE:	10/29/13
DISPOSAL PROCESS(ES):	LANDFILL
FINAL DISPOSAL LOCATION:	LANDFILL 13
DISPOSAL DATE:	10/29/13

I certify, on behalf of the above listed treatment facility, that to the best of my knowledge, the above-described waste material was managed in compliance with all applicable laws, regulations, permits and licenses on the date listed above.

Becky Sumner

CWMNW RECORDS DEPARTMENT

Date: 10/31/13



WASTE MANAGEMENT
17629 Cedar Springs Lane
Arlington, OR 97812

PORT OF TACOMA
WAD001882984
3400 TAYLOR WAY
TACOMA WA 98421

CERTIFICATE OF DISPOSAL

Chemical Waste Management of the Northwest, Inc., ORD089452353, has received the following waste material:

GENERATOR:	PORT OF TACOMA
MANIFEST #:	011886953JJK
CWM TRACKING ID:	430041-01
PROFILE #:	OR321468
LINE ITEM:	9b.1
QUANTITY:	1 DT
RECEIVED DATE:	10/29/13
DISPOSAL PROCESS(ES):	LANDFILL
FINAL DISPOSAL LOCATION:	LANDFILL 13
DISPOSAL DATE:	10/29/13

I certify, on behalf of the above listed treatment facility, that to the best of my knowledge, the above-described waste material was managed in compliance with all applicable laws, regulations, permits and licenses on the date listed above.

Becky Sumner

CWMNW RECORDS DEPARTMENT

Date: 10/31/13



WASTE MANAGEMENT
17629 Cedar Springs Lane
Arlington, OR 97812

PORT OF TACOMA
WAD001882984
3400 TAYLOR WAY
TACOMA WA 98421

CERTIFICATE OF DISPOSAL

Chemical Waste Management of the Northwest, Inc., ORD089452353, has received the following waste material:

GENERATOR:	PORT OF TACOMA
MANIFEST #:	011886942JJK
CWM TRACKING ID:	430042-01
PROFILE #:	OR321468
LINE ITEM:	9b.1
QUANTITY:	1 DT
RECEIVED DATE:	10/29/13
DISPOSAL PROCESS(ES):	LANDFILL
FINAL DISPOSAL LOCATION:	LANDFILL 13
DISPOSAL DATE:	10/29/13

I certify, on behalf of the above listed treatment facility, that to the best of my knowledge, the above-described waste material was managed in compliance with all applicable laws, regulations, permits and licenses on the date listed above.

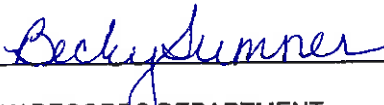

CWMNW RECORDS DEPARTMENT

Date: 10/31/13



WASTE MANAGEMENT
17629 Cedar Springs Lane
Arlington, OR 97812

PORT OF TACOMA
WAD001882984
3400 TAYLOR WAY
TACOMA WA 98421

CERTIFICATE OF DISPOSAL

Chemical Waste Management of the Northwest, Inc., ORD089452353, has received the following waste material:

GENERATOR:	PORT OF TACOMA
MANIFEST #:	011886947JJK
CWM TRACKING ID:	430045-01
PROFILE #:	OR321468
LINE ITEM:	9b.1
QUANTITY:	1 DT
RECEIVED DATE:	10/29/13
DISPOSAL PROCESS(ES):	LANDFILL
FINAL DISPOSAL LOCATION:	LANDFILL 13
DISPOSAL DATE:	10/29/13

I certify, on behalf of the above listed treatment facility, that to the best of my knowledge, the above-described waste material was managed in compliance with all applicable laws, regulations, permits and licenses on the date listed above.

Becky Sumner

CWMNW RECORDS DEPARTMENT

Date: 10/31/13



WASTE MANAGEMENT
17629 Cedar Springs Lane
Arlington, OR 97812

NOV 22 2013

PORT OF TACOMA
WAD001882984
3400 TAYLOR WAY
TACOMA WA 98421

CERTIFICATE OF DISPOSAL

Chemical Waste Management of the Northwest, Inc., ORD089452353, has received the following waste material:

GENERATOR:	PORT OF TACOMA
MANIFEST #:	011886945JJK
CWM TRACKING ID:	430059-01
PROFILE #:	OR321468
LINE ITEM:	9b.1
QUANTITY:	1 DT
RECEIVED DATE:	10/30/13
DISPOSAL PROCESS(ES):	LANDFILL
FINAL DISPOSAL LOCATION:	LANDFILL 14
DISPOSAL DATE:	10/30/13

I certify, on behalf of the above listed treatment facility, that to the best of my knowledge, the above-described waste material was managed in compliance with all applicable laws, regulations, permits and licenses on the date listed above.

Becky Sumner

CWMNW RECORDS DEPARTMENT

Date: 11/12/13



WASTE MANAGEMENT
17629 Cedar Springs Lane
Arlington, OR 97812

PORT OF TACOMA
WAD001882984
3400 TAYLOR WAY
TACOMA WA 98421

CERTIFICATE OF DISPOSAL

Chemical Waste Management of the Northwest, Inc., ORD089452353, has received the following waste material:

GENERATOR:	PORT OF TACOMA
MANIFEST #:	011886933JJK
CWM TRACKING ID:	430084-01
PROFILE #:	OR321468
LINE ITEM:	9b.1
QUANTITY:	1 DT
RECEIVED DATE:	10/30/13
DISPOSAL PROCESS(ES):	LANDFILL
FINAL DISPOSAL LOCATION:	LANDFILL 14
DISPOSAL DATE:	10/30/13

I certify, on behalf of the above listed treatment facility, that to the best of my knowledge, the above-described waste material was managed in compliance with all applicable laws, regulations, permits and licenses on the date listed above.

Becky Sumner

_____ CWMNW RECORDS DEPARTMENT

Date: 11/12/13



WASTE MANAGEMENT
17629 Cedar Springs Lane
Arlington, OR 97812

PORT OF TACOMA
WAD001882984
3400 TAYLOR WAY
TACOMA WA 98421

CERTIFICATE OF DISPOSAL

Chemical Waste Management of the Northwest, Inc., ORD089452353, has received the following waste material:

GENERATOR:	PORT OF TACOMA
MANIFEST #:	011886934JJK
CWM TRACKING ID:	430088-01
PROFILE #:	OR321468
LINE ITEM:	9b.1
QUANTITY:	1 DT
RECEIVED DATE:	10/30/13
DISPOSAL PROCESS(ES):	LANDFILL
FINAL DISPOSAL LOCATION:	LANDFILL 14
DISPOSAL DATE:	10/30/13

I certify, on behalf of the above listed treatment facility, that to the best of my knowledge, the above-described waste material was managed in compliance with all applicable laws, regulations, permits and licenses on the date listed above.

Becky Sumner

_____ CWMNW RECORDS DEPARTMENT

Date: 11/12/13



WASTE MANAGEMENT
17629 Cedar Springs Lane
Arlington, OR 97812

PORT OF TACOMA
WAD001882984
3400 TAYLOR WAY
TACOMA WA 98421

CERTIFICATE OF DISPOSAL

Chemical Waste Management of the Northwest, Inc., ORD089452353, has received the following waste material:

GENERATOR:	PORT OF TACOMA
MANIFEST #:	011886935JJK
CWM TRACKING ID:	430089-01
PROFILE #:	OR321468
LINE ITEM:	9b.1
QUANTITY:	1 DT
RECEIVED DATE:	10/30/13
DISPOSAL PROCESS(ES):	LANDFILL
FINAL DISPOSAL LOCATION:	LANDFILL 14
DISPOSAL DATE:	10/30/13

I certify, on behalf of the above listed treatment facility, that to the best of my knowledge, the above-described waste material was managed in compliance with all applicable laws, regulations, permits and licenses on the date listed above.

Becky Sumner

_____ CWMNW RECORDS DEPARTMENT

Date: 11/12/13



WASTE MANAGEMENT

17629 Cedar Springs Lane
Arlington, OR 97812

PORT OF TACOMA
WAD001882984
3400 TAYLOR WAY
TACOMA WA 98421

CERTIFICATE OF DISPOSAL

Chemical Waste Management of the Northwest, Inc., ORD089452353, has received the following waste material:

GENERATOR:	PORT OF TACOMA
MANIFEST #:	011886937JJK
CWM TRACKING ID:	430090-01
PROFILE #:	OR321468
LINE ITEM:	9b.1
QUANTITY:	1 DT
RECEIVED DATE:	10/30/13
DISPOSAL PROCESS(ES):	LANDFILL
FINAL DISPOSAL LOCATION:	LANDFILL 14
DISPOSAL DATE:	10/30/13

I certify, on behalf of the above listed treatment facility, that to the best of my knowledge, the above-described waste material was managed in compliance with all applicable laws, regulations, permits and licenses on the date listed above.

Becky Sumner

CWMNW RECORDS DEPARTMENT

Date: 11/12/13



WASTE MANAGEMENT

17629 Cedar Springs Lane
Arlington, OR 97812

PORT OF TACOMA
WAD001882984
3400 TAYLOR WAY
TACOMA WA 98421

CERTIFICATE OF DISPOSAL

Chemical Waste Management of the Northwest, Inc., ORD089452353, has received the following waste material:

GENERATOR:	PORT OF TACOMA
MANIFEST #:	011886936JJK
CWM TRACKING ID:	430091-01
PROFILE #:	OR321468
LINE ITEM:	9b.1
QUANTITY:	1 DT
RECEIVED DATE:	10/30/13
DISPOSAL PROCESS(ES):	LANDFILL
FINAL DISPOSAL LOCATION:	LANDFILL 14
DISPOSAL DATE:	10/30/13

I certify, on behalf of the above listed treatment facility, that to the best of my knowledge, the above-described waste material was managed in compliance with all applicable laws, regulations, permits and licenses on the date listed above.



CWMNW RECORDS DEPARTMENT

Date: 11/12/13



WASTE MANAGEMENT
17629 Cedar Springs Lane
Arlington, OR 97812

PORT OF TACOMA
WAD001882984
3400 TAYLOR WAY
TACOMA WA 98421

CERTIFICATE OF DISPOSAL

Chemical Waste Management of the Northwest, Inc., ORD089452353, has received the following waste material:

GENERATOR:	PORT OF TACOMA
MANIFEST #:	011886938JJK
CWM TRACKING ID:	430092-01
PROFILE #:	OR321468
LINE ITEM:	9b.1
QUANTITY:	1 DT
RECEIVED DATE:	10/30/13
DISPOSAL PROCESS(ES):	LANDFILL
FINAL DISPOSAL LOCATION:	LANDFILL 14
DISPOSAL DATE:	10/30/13

I certify, on behalf of the above listed treatment facility, that to the best of my knowledge, the above-described waste material was managed in compliance with all applicable laws, regulations, permits and licenses on the date listed above.

Becky Sumner

CWMNW RECORDS DEPARTMENT
Date: 11/12/13



WASTE MANAGEMENT
17629 Cedar Springs Lane
Arlington, OR 97812

PORT OF TACOMA
WAD001882984
3400 TAYLOR WAY
TACOMA WA 98421

CERTIFICATE OF DISPOSAL

Chemical Waste Management of the Northwest, Inc., ORD089452353, has received the following waste material:

GENERATOR:	PORT OF TACOMA
MANIFEST #:	011886941JJK
CWM TRACKING ID:	430093-01
PROFILE #:	OR321468
LINE ITEM:	9b.1
QUANTITY:	1 DT
RECEIVED DATE:	10/30/13
DISPOSAL PROCESS(ES):	LANDFILL
FINAL DISPOSAL LOCATION:	LANDFILL 14
DISPOSAL DATE:	10/30/13

I certify, on behalf of the above listed treatment facility, that to the best of my knowledge, the above-described waste material was managed in compliance with all applicable laws, regulations, permits and licenses on the date listed above.

Becky Sumner

CWMNW RECORDS DEPARTMENT

Date: 11/12/13



WASTE MANAGEMENT

17629 Cedar Springs Lane
Arlington, OR 97812

PORT OF TACOMA
WAD001882984
3400 TAYLOR WAY
TACOMA WA 98421

CERTIFICATE OF DISPOSAL

Chemical Waste Management of the Northwest, Inc., ORD089452353, has received the following waste material:

GENERATOR:	PORT OF TACOMA
MANIFEST #:	011886932JJK
CWM TRACKING ID:	430094-01
PROFILE #:	OR321468
LINE ITEM:	9b.1
QUANTITY:	1 DT
RECEIVED DATE:	10/30/13
DISPOSAL PROCESS(ES):	LANDFILL
FINAL DISPOSAL LOCATION:	LANDFILL 14
DISPOSAL DATE:	10/30/13

I certify, on behalf of the above listed treatment facility, that to the best of my knowledge, the above-described waste material was managed in compliance with all applicable laws, regulations, permits and licenses on the date listed above.

Becky Sumner

CWMNW RECORDS DEPARTMENT

Date: 11/12/13



WASTE MANAGEMENT

17629 Cedar Springs Lane
Arlington, OR 97812

PORT OF TACOMA
WAD001882984
3400 TAYLOR WAY
TACOMA WA 98421

CERTIFICATE OF DISPOSAL

Chemical Waste Management of the Northwest, Inc., ORD089452353, has received the following waste material:

GENERATOR:	PORT OF TACOMA
MANIFEST #:	011886940JJK
CWM TRACKING ID:	430095-01
PROFILE #:	OR321468
LINE ITEM:	9b.1
QUANTITY:	1 DT
RECEIVED DATE:	10/30/13
DISPOSAL PROCESS(ES):	LANDFILL
FINAL DISPOSAL LOCATION:	LANDFILL 14
DISPOSAL DATE:	10/30/13

I certify, on behalf of the above listed treatment facility, that to the best of my knowledge, the above-described waste material was managed in compliance with all applicable laws, regulations, permits and licenses on the date listed above.

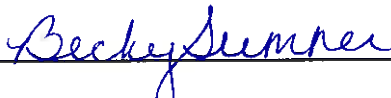

CWMNW RECORDS DEPARTMENT

Date: 11/12/13



WASTE MANAGEMENT
17629 Cedar Springs Lane
Arlington, OR 97812

PORT OF TACOMA
WAD001882984
3400 TAYLOR WAY
TACOMA WA 98421

CERTIFICATE OF DISPOSAL

Chemical Waste Management of the Northwest, Inc., ORD089452353, has received the following waste material:

GENERATOR:	PORT OF TACOMA
MANIFEST #:	011886939JJK
CWM TRACKING ID:	430096-01
PROFILE #:	OR321468
LINE ITEM:	9b.1
QUANTITY:	1 DT
RECEIVED DATE:	10/30/13
DISPOSAL PROCESS(ES):	LANDFILL
FINAL DISPOSAL LOCATION:	LANDFILL 14
DISPOSAL DATE:	10/30/13

I certify, on behalf of the above listed treatment facility, that to the best of my knowledge, the above-described waste material was managed in compliance with all applicable laws, regulations, permits and licenses on the date listed above.

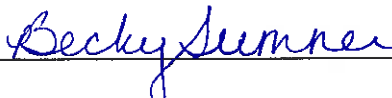

CWMNW RECORDS DEPARTMENT

Date: 11/12/13



WASTE MANAGEMENT
17629 Cedar Springs Lane
Arlington, OR 97812

PORT OF TACOMA
WAD001882984
3400 TAYLOR WAY
TACOMA WA 98421

CERTIFICATE OF DISPOSAL

Chemical Waste Management of the Northwest, Inc., ORD089452353, has received the following waste material:

GENERATOR:	PORT OF TACOMA
MANIFEST #:	011886929JJK
CWM TRACKING ID:	430098-01
PROFILE #:	OR321468
LINE ITEM:	9b.1
QUANTITY:	1 DT
RECEIVED DATE:	10/30/13
DISPOSAL PROCESS(ES):	LANDFILL
FINAL DISPOSAL LOCATION:	LANDFILL 14
DISPOSAL DATE:	10/30/13

I certify, on behalf of the above listed treatment facility, that to the best of my knowledge, the above-described waste material was managed in compliance with all applicable laws, regulations, permits and licenses on the date listed above.

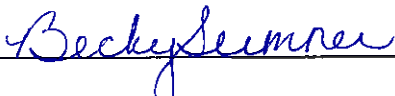

CWMNW RECORDS DEPARTMENT

Date: 11/12/13



WASTE MANAGEMENT

17629 Cedar Springs Lane
Arlington, OR 97812

PORT OF TACOMA
WAD001882984
3400 TAYLOR WAY
TACOMA WA 98421

CERTIFICATE OF DISPOSAL

Chemical Waste Management of the Northwest, Inc., ORD089452353, has received the following waste material:

GENERATOR:	PORT OF TACOMA
MANIFEST #:	011886928JJK
CWM TRACKING ID:	430099-01
PROFILE #:	OR321468
LINE ITEM:	9b.1
QUANTITY:	1 DT
RECEIVED DATE:	10/30/13
DISPOSAL PROCESS(ES):	LANDFILL
FINAL DISPOSAL LOCATION:	LANDFILL 14
DISPOSAL DATE:	10/30/13

I certify, on behalf of the above listed treatment facility, that to the best of my knowledge, the above-described waste material was managed in compliance with all applicable laws, regulations, permits and licenses on the date listed above.



CWMNW RECORDS DEPARTMENT

Date: 11/12/13



WASTE MANAGEMENT

17629 Cedar Springs Lane
Arlington, OR 97812

PORT OF TACOMA
WAD001882984
3400 TAYLOR WAY
TACOMA WA 98421

CERTIFICATE OF DISPOSAL

Chemical Waste Management of the Northwest, Inc., ORD089452353, has received the following waste material:

GENERATOR:	PORT OF TACOMA
MANIFEST #:	011886927JJK
CWM TRACKING ID:	430100-01
PROFILE #:	OR321468
LINE ITEM:	9b.1
QUANTITY:	1 DT
RECEIVED DATE:	10/30/13
DISPOSAL PROCESS(ES):	LANDFILL
FINAL DISPOSAL LOCATION:	LANDFILL 14
DISPOSAL DATE:	10/30/13

I certify, on behalf of the above listed treatment facility, that to the best of my knowledge, the above-described waste material was managed in compliance with all applicable laws, regulations, permits and licenses on the date listed above.

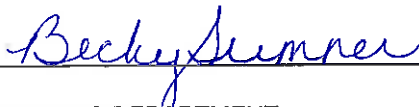

CWMNW RECORDS DEPARTMENT

Date: 11/12/13



WASTE MANAGEMENT
17629 Cedar Springs Lane
Arlington, OR 97812

PORT OF TACOMA
WAD001882984
3400 TAYLOR WAY
TACOMA WA 98421

CERTIFICATE OF DISPOSAL

Chemical Waste Management of the Northwest, Inc., ORD089452353, has received the following waste material:

GENERATOR:	PORT OF TACOMA
MANIFEST #:	011886930JJK
CWM TRACKING ID:	430101-01
PROFILE #:	OR321468
LINE ITEM:	9b.1
QUANTITY:	1 DT
RECEIVED DATE:	10/30/13
DISPOSAL PROCESS(ES):	LANDFILL
FINAL DISPOSAL LOCATION:	LANDFILL 14
DISPOSAL DATE:	10/30/13

I certify, on behalf of the above listed treatment facility, that to the best of my knowledge, the above-described waste material was managed in compliance with all applicable laws, regulations, permits and licenses on the date listed above.

CWMNW RECORDS DEPARTMENT
Date:

11/12/13



WASTE MANAGEMENT
17629 Cedar Springs Lane
Arlington, OR 97812

PORT OF TACOMA
WAD001882984
3400 TAYLOR WAY
TACOMA WA 98421

CERTIFICATE OF DISPOSAL

Chemical Waste Management of the Northwest, Inc., ORD089452353, has received the following waste material:

GENERATOR:	PORT OF TACOMA
MANIFEST #:	011886926JJK
CWM TRACKING ID:	430102-01
PROFILE #:	OR321468
LINE ITEM:	9b.1
QUANTITY:	1 DT
RECEIVED DATE:	10/30/13
DISPOSAL PROCESS(ES):	LANDFILL
FINAL DISPOSAL LOCATION:	LANDFILL 14
DISPOSAL DATE:	10/30/13

I certify, on behalf of the above listed treatment facility, that to the best of my knowledge, the above-described waste material was managed in compliance with all applicable laws, regulations, permits and licenses on the date listed above.

CWMNW RECORDS DEPARTMENT

Date: 11/12/13



WASTE MANAGEMENT
17629 Cedar Springs Lane
Arlington, OR 97812

PORT OF TACOMA
WAD001882984
3400 TAYLOR WAY
TACOMA WA 98421

CERTIFICATE OF DISPOSAL

Chemical Waste Management of the Northwest, Inc., ORD089452353, has received the following waste material:

GENERATOR:	PORT OF TACOMA
MANIFEST #:	011886925JJK
CWM TRACKING ID:	430105-01
PROFILE #:	OR321468
LINE ITEM:	9b.1
QUANTITY:	1 DT
RECEIVED DATE:	10/30/13
DISPOSAL PROCESS(ES):	LANDFILL
FINAL DISPOSAL LOCATION:	LANDFILL 14
DISPOSAL DATE:	10/30/13

I certify, on behalf of the above listed treatment facility, that to the best of my knowledge, the above-described waste material was managed in compliance with all applicable laws, regulations, permits and licenses on the date listed above.

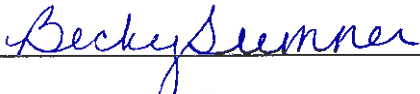

CWMNW RECORDS DEPARTMENT

Date: 11/12/13



WASTE MANAGEMENT

17629 Cedar Springs Lane
Arlington, OR 97812

PORT OF TACOMA
WAD001882984
3400 TAYLOR WAY
TACOMA WA 98421

CERTIFICATE OF DISPOSAL

Chemical Waste Management of the Northwest, Inc., ORD089452353, has received the following waste material:

GENERATOR:	PORT OF TACOMA
MANIFEST #:	011886931JJK
CWM TRACKING ID:	430109-01
PROFILE #:	OR321468
LINE ITEM:	9b.1
QUANTITY:	1 DT
RECEIVED DATE:	10/30/13
DISPOSAL PROCESS(ES):	LANDFILL
FINAL DISPOSAL LOCATION:	LANDFILL 14
DISPOSAL DATE:	10/30/13

I certify, on behalf of the above listed treatment facility, that to the best of my knowledge, the above-described waste material was managed in compliance with all applicable laws, regulations, permits and licenses on the date listed above.

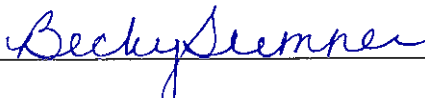

CWMNW RECORDS DEPARTMENT

Date: 11/12/13



WASTE MANAGEMENT

17629 Cedar Springs Lane
Arlington, OR 97812

PORT OF TACOMA
WAD001882984
3400 TAYLOR WAY
TACOMA WA 98421

CERTIFICATE OF DISPOSAL

Chemical Waste Management of the Northwest, Inc., ORD089452353, has received the following waste material:

GENERATOR:	PORT OF TACOMA
MANIFEST #:	011886924JJK
CWM TRACKING ID:	430126-01
PROFILE #:	OR321468
LINE ITEM:	9b.1
QUANTITY:	1 DT
RECEIVED DATE:	10/31/13
DISPOSAL PROCESS(ES):	LANDFILL
FINAL DISPOSAL LOCATION:	LANDFILL 14
DISPOSAL DATE:	10/31/13

I certify, on behalf of the above listed treatment facility, that to the best of my knowledge, the above-described waste material was managed in compliance with all applicable laws, regulations, permits and licenses on the date listed above.

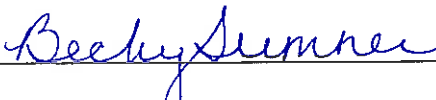

CWMNW RECORDS DEPARTMENT

Date: 11/12/13



WASTE MANAGEMENT

17629 Cedar Springs Lane
Arlington, OR 97812

PORT OF TACOMA
WAD001882984
3400 TAYLOR WAY
TACOMA WA 98421

CERTIFICATE OF DISPOSAL

Chemical Waste Management of the Northwest, Inc., ORD089452353, has received the following waste material:

GENERATOR:	PORT OF TACOMA
MANIFEST #:	011886923JJK
CWM TRACKING ID:	430147-01
PROFILE #:	OR321468
LINE ITEM:	9b.1
QUANTITY:	1 DT
RECEIVED DATE:	10/31/13
DISPOSAL PROCESS(ES):	LANDFILL
FINAL DISPOSAL LOCATION:	LANDFILL 14
DISPOSAL DATE:	10/31/13

I certify, on behalf of the above listed treatment facility, that to the best of my knowledge, the above-described waste material was managed in compliance with all applicable laws, regulations, permits and licenses on the date listed above.

Becky Sumner

CWMNW RECORDS DEPARTMENT

Date: 11/12/13



WASTE MANAGEMENT

17629 Cedar Springs Lane
Arlington, OR 97812

PORT OF TACOMA
WAD001882984
3400 TAYLOR WAY
TACOMA WA 98421

CERTIFICATE OF DISPOSAL

Chemical Waste Management of the Northwest, Inc., ORD089452353, has received the following waste material:

GENERATOR:	PORT OF TACOMA
MANIFEST #:	011886922JJK
CWM TRACKING ID:	430148-01
PROFILE #:	OR321468
LINE ITEM:	9b.1
QUANTITY:	1 DT
RECEIVED DATE:	10/31/13
DISPOSAL PROCESS(ES):	LANDFILL
FINAL DISPOSAL LOCATION:	LANDFILL 14
DISPOSAL DATE:	10/31/13

I certify, on behalf of the above listed treatment facility, that to the best of my knowledge, the above-described waste material was managed in compliance with all applicable laws, regulations, permits and licenses on the date listed above.

CWMNW RECORDS DEPARTMENT

Date: 11/12/13



WASTE MANAGEMENT

17629 Cedar Springs Lane
Arlington, OR 97812

PORT OF TACOMA
WAD001882984
3400 TAYLOR WAY
TACOMA WA 98421

CERTIFICATE OF DISPOSAL

Chemical Waste Management of the Northwest, Inc., ORD089452353, has received the following waste material:

GENERATOR:	PORT OF TACOMA
MANIFEST #:	011886921JJK
CWM TRACKING ID:	430150-01
PROFILE #:	OR321468
LINE ITEM:	9b.1
QUANTITY:	1 DT
RECEIVED DATE:	10/31/13
DISPOSAL PROCESS(ES):	LANDFILL
FINAL DISPOSAL LOCATION:	LANDFILL 14
DISPOSAL DATE:	10/31/13

I certify, on behalf of the above listed treatment facility, that to the best of my knowledge, the above-described waste material was managed in compliance with all applicable laws, regulations, permits and licenses on the date listed above.

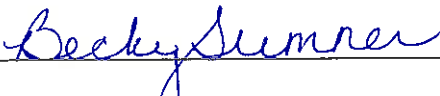

CWMNW RECORDS DEPARTMENT

Date: 11/12/13



WASTE MANAGEMENT
17629 Cedar Springs Lane
Arlington, OR 97812

PORT OF TACOMA
WAD001882984
3400 TAYLOR WAY
TACOMA WA 98421

CERTIFICATE OF DISPOSAL

Chemical Waste Management of the Northwest, Inc., ORD089452353, has received the following waste material:

GENERATOR:	PORT OF TACOMA
MANIFEST #:	011886920JJK
CWM TRACKING ID:	430153-01
PROFILE #:	OR321468
LINE ITEM:	9b.1
QUANTITY:	1 DT
RECEIVED DATE:	10/31/13
DISPOSAL PROCESS(ES):	LANDFILL
FINAL DISPOSAL LOCATION:	LANDFILL 14
DISPOSAL DATE:	10/31/13

I certify, on behalf of the above listed treatment facility, that to the best of my knowledge, the above-described waste material was managed in compliance with all applicable laws, regulations, permits and licenses on the date listed above.

Becky Sumner

CWMNW RECORDS DEPARTMENT

Date: 11/12/13



WASTE MANAGEMENT
17629 Cedar Springs Lane
Arlington, OR 97812

PORT OF TACOMA
WAD001882984
3400 TAYLOR WAY
TACOMA WA 98421

CERTIFICATE OF DISPOSAL

Chemical Waste Management of the Northwest, Inc., ORD089452353, has received the following waste material:

GENERATOR:	PORT OF TACOMA
MANIFEST #:	011886919JJK
CWM TRACKING ID:	430154-01
PROFILE #:	OR321468
LINE ITEM:	9b.1
QUANTITY:	1 DT
RECEIVED DATE:	10/31/13
DISPOSAL PROCESS(ES):	LANDFILL
FINAL DISPOSAL LOCATION:	LANDFILL 14
DISPOSAL DATE:	10/31/13

I certify, on behalf of the above listed treatment facility, that to the best of my knowledge, the above-described waste material was managed in compliance with all applicable laws, regulations, permits and licenses on the date listed above.

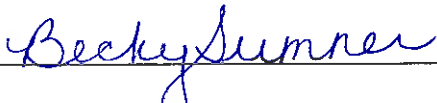

CWMNW RECORDS DEPARTMENT

Date: 11/12/13



WASTE MANAGEMENT

17629 Cedar Springs Lane
Arlington, OR 97812

PORT OF TACOMA
WAD001882984
3400 TAYLOR WAY
TACOMA WA 98421

CERTIFICATE OF DISPOSAL

Chemical Waste Management of the Northwest, Inc., ORD089452353, has received the following waste material:

GENERATOR:	PORT OF TACOMA
MANIFEST #:	011886915JJK
CWM TRACKING ID:	430155-01
PROFILE #:	OR321468
LINE ITEM:	9b.1
QUANTITY:	1 DT
RECEIVED DATE:	10/31/13
DISPOSAL PROCESS(ES):	LANDFILL
FINAL DISPOSAL LOCATION:	LANDFILL 14
DISPOSAL DATE:	10/31/13

I certify, on behalf of the above listed treatment facility, that to the best of my knowledge, the above-described waste material was managed in compliance with all applicable laws, regulations, permits and licenses on the date listed above.

Becky Sumner

CWMNW RECORDS DEPARTMENT

Date: 11/12/13



WASTE MANAGEMENT

17629 Cedar Springs Lane
Arlington, OR 97812

PORT OF TACOMA
WAD001882984
3400 TAYLOR WAY
TACOMA WA 98421

CERTIFICATE OF DISPOSAL

Chemical Waste Management of the Northwest, Inc., ORD089452353, has received the following waste material:

GENERATOR:	PORT OF TACOMA
MANIFEST #:	011886916JJK
CWM TRACKING ID:	430156-01
PROFILE #:	OR321468
LINE ITEM:	9b.1
QUANTITY:	1 DT
RECEIVED DATE:	10/31/13
DISPOSAL PROCESS(ES):	LANDFILL
FINAL DISPOSAL LOCATION:	LANDFILL 14
DISPOSAL DATE:	10/31/13

I certify, on behalf of the above listed treatment facility, that to the best of my knowledge, the above-described waste material was managed in compliance with all applicable laws, regulations, permits and licenses on the date listed above.

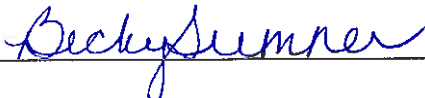

CWMNW RECORDS DEPARTMENT

Date: 11/12/13



WASTE MANAGEMENT
17629 Cedar Springs Lane
Arlington, OR 97812

PORT OF TACOMA
WAD001882984
3400 TAYLOR WAY
TACOMA WA 98421

CERTIFICATE OF DISPOSAL

Chemical Waste Management of the Northwest, Inc., ORD089452353, has received the following waste material:

GENERATOR:	PORT OF TACOMA
MANIFEST #:	011886917JJK
CWM TRACKING ID:	430157-01
PROFILE #:	OR321468
LINE ITEM:	9b.1
QUANTITY:	1 DT
RECEIVED DATE:	10/31/13
DISPOSAL PROCESS(ES):	LANDFILL
FINAL DISPOSAL LOCATION:	LANDFILL 14
DISPOSAL DATE:	10/31/13

I certify, on behalf of the above listed treatment facility, that to the best of my knowledge, the above-described waste material was managed in compliance with all applicable laws, regulations, permits and licenses on the date listed above.

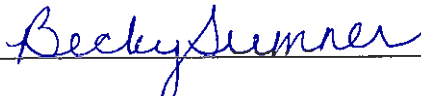

CWMNW RECORDS DEPARTMENT

Date: 11/12/13



WASTE MANAGEMENT
17629 Cedar Springs Lane
Arlington, OR 97812

PORT OF TACOMA
WAD001882984
3400 TAYLOR WAY
TACOMA WA 98421

CERTIFICATE OF DISPOSAL

Chemical Waste Management of the Northwest, Inc., ORD089452353, has received the following waste material:

GENERATOR:	PORT OF TACOMA
MANIFEST #:	011886913JJK
CWM TRACKING ID:	430160-01
PROFILE #:	OR321468
LINE ITEM:	9b.1
QUANTITY:	1 DT
RECEIVED DATE:	10/31/13
DISPOSAL PROCESS(ES):	LANDFILL
FINAL DISPOSAL LOCATION:	LANDFILL 14
DISPOSAL DATE:	10/31/13

I certify, on behalf of the above listed treatment facility, that to the best of my knowledge, the above-described waste material was managed in compliance with all applicable laws, regulations, permits and licenses on the date listed above.

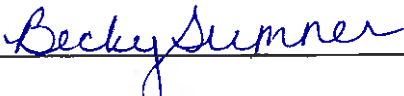

CWMNW RECORDS DEPARTMENT

Date: 11/12/13



WASTE MANAGEMENT
17629 Cedar Springs Lane
Arlington, OR 97812

PORT OF TACOMA
WAD001882984
3400 TAYLOR WAY
TACOMA WA 98421

CERTIFICATE OF DISPOSAL

Chemical Waste Management of the Northwest, Inc., ORD089452353, has received the following waste material:

GENERATOR:	PORT OF TACOMA
MANIFEST #:	011886914JJK
CWM TRACKING ID:	430161-01
PROFILE #:	OR321468
LINE ITEM:	9b.1
QUANTITY:	1 DT
RECEIVED DATE:	10/31/13
DISPOSAL PROCESS(ES):	LANDFILL
FINAL DISPOSAL LOCATION:	LANDFILL 14
DISPOSAL DATE:	10/31/13

I certify, on behalf of the above listed treatment facility, that to the best of my knowledge, the above-described waste material was managed in compliance with all applicable laws, regulations, permits and licenses on the date listed above.

Becky Sumner

CWMNW RECORDS DEPARTMENT

Date: 11/12/13



WASTE MANAGEMENT
17629 Cedar Springs Lane
Arlington, OR 97812

PORT OF TACOMA
WAD001882984
3400 TAYLOR WAY
TACOMA WA 98421

CERTIFICATE OF DISPOSAL

Chemical Waste Management of the Northwest, Inc., ORD089452353, has received the following waste material:

GENERATOR:	PORT OF TACOMA
MANIFEST #:	011886918JJK
CWM TRACKING ID:	430162-01
PROFILE #:	OR321468
LINE ITEM:	9b.1
QUANTITY:	1 DT
RECEIVED DATE:	10/31/13
DISPOSAL PROCESS(ES):	LANDFILL
FINAL DISPOSAL LOCATION:	LANDFILL 14
DISPOSAL DATE:	10/31/13

I certify, on behalf of the above listed treatment facility, that to the best of my knowledge, the above-described waste material was managed in compliance with all applicable laws, regulations, permits and licenses on the date listed above.

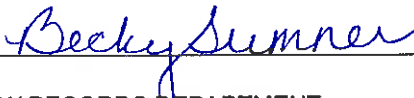

CWMNW RECORDS DEPARTMENT

Date: 11/12/13



WASTE MANAGEMENT
17629 Cedar Springs Lane
Arlington, OR 97812

PORT OF TACOMA
WAD001882984
3400 TAYLOR WAY
TACOMA WA 98421

CERTIFICATE OF DISPOSAL

Chemical Waste Management of the Northwest, Inc., ORD089452353, has received the following waste material:

GENERATOR:	PORT OF TACOMA
MANIFEST #:	011886908JJK
CWM TRACKING ID:	430164-01
PROFILE #:	OR321468
LINE ITEM:	9b.1
QUANTITY:	1 DT
RECEIVED DATE:	10/31/13
DISPOSAL PROCESS(ES):	LANDFILL
FINAL DISPOSAL LOCATION:	LANDFILL 14
DISPOSAL DATE:	10/31/13

I certify, on behalf of the above listed treatment facility, that to the best of my knowledge, the above-described waste material was managed in compliance with all applicable laws, regulations, permits and licenses on the date listed above.

CWMNW RECORDS DEPARTMENT

Date: 11/12/13



WASTE MANAGEMENT

17629 Cedar Springs Lane
Arlington, OR 97812

PORT OF TACOMA
WAD001882984
3400 TAYLOR WAY
TACOMA WA 98421

CERTIFICATE OF DISPOSAL

Chemical Waste Management of the Northwest, Inc., ORD089452353, has received the following waste material:

GENERATOR:	PORT OF TACOMA
MANIFEST #:	011886912JJK
CWM TRACKING ID:	430166-01
PROFILE #:	OR321468
LINE ITEM:	9b.1
QUANTITY:	1 DT
RECEIVED DATE:	10/31/13
DISPOSAL PROCESS(ES):	LANDFILL
FINAL DISPOSAL LOCATION:	LANDFILL 14
DISPOSAL DATE:	10/31/13

I certify, on behalf of the above listed treatment facility, that to the best of my knowledge, the above-described waste material was managed in compliance with all applicable laws, regulations, permits and licenses on the date listed above.

CWMNW RECORDS DEPARTMENT

Date: 11/12/13



WASTE MANAGEMENT
17629 Cedar Springs Lane
Arlington, OR 97812

PORT OF TACOMA
WAD001882984
3400 TAYLOR WAY
TACOMA WA 98421

CERTIFICATE OF DISPOSAL

Chemical Waste Management of the Northwest, Inc., ORD089452353, has received the following waste material:

GENERATOR:	PORT OF TACOMA
MANIFEST #:	011886907JJK
CWM TRACKING ID:	430171-01
PROFILE #:	OR321468
LINE ITEM:	9b.1
QUANTITY:	1 DT
RECEIVED DATE:	10/31/13
DISPOSAL PROCESS(ES):	LANDFILL
FINAL DISPOSAL LOCATION:	LANDFILL 14
DISPOSAL DATE:	10/31/13

I certify, on behalf of the above listed treatment facility, that to the best of my knowledge, the above-described waste material was managed in compliance with all applicable laws, regulations, permits and licenses on the date listed above.

Becky Sumner

CWMNW RECORDS DEPARTMENT

Date: 11/12/13



WASTE MANAGEMENT
17629 Cedar Springs Lane
Arlington, OR 97812

PORT OF TACOMA
WAD001882984
3400 TAYLOR WAY
TACOMA WA 98421

CERTIFICATE OF DISPOSAL

Chemical Waste Management of the Northwest, Inc., ORD089452353, has received the following waste material:

GENERATOR:	PORT OF TACOMA
MANIFEST #:	011886909JJK
CWM TRACKING ID:	430183-01
PROFILE #:	OR321468
LINE ITEM:	9b.1
QUANTITY:	1 DT
RECEIVED DATE:	11/01/13
DISPOSAL PROCESS(ES):	LANDFILL
FINAL DISPOSAL LOCATION:	LANDFILL 14
DISPOSAL DATE:	11/01/13

I certify, on behalf of the above listed treatment facility, that to the best of my knowledge, the above-described waste material was managed in compliance with all applicable laws, regulations, permits and licenses on the date listed above.

CWMNW RECORDS DEPARTMENT

Date: 11/12/13



WASTE MANAGEMENT
17629 Cedar Springs Lane
Arlington, OR 97812

PORT OF TACOMA
WAD001882984
3400 TAYLOR WAY
TACOMA WA 98421

CERTIFICATE OF DISPOSAL

Chemical Waste Management of the Northwest, Inc., ORD089452353, has received the following waste material:

GENERATOR:	PORT OF TACOMA
MANIFEST #:	011886906JJK
CWM TRACKING ID:	430208-01
PROFILE #:	OR321468
LINE ITEM:	9b.1
QUANTITY:	1 DT
RECEIVED DATE:	11/01/13
DISPOSAL PROCESS(ES):	LANDFILL
FINAL DISPOSAL LOCATION:	LANDFILL 14
DISPOSAL DATE:	11/01/13

I certify, on behalf of the above listed treatment facility, that to the best of my knowledge, the above-described waste material was managed in compliance with all applicable laws, regulations, permits and licenses on the date listed above.

Becky Sumner

CWMNW RECORDS DEPARTMENT

Date: 11/12/13



WASTE MANAGEMENT

17629 Cedar Springs Lane
Arlington, OR 97812

PORT OF TACOMA
WAD001882984
3400 TAYLOR WAY
TACOMA WA 98421

CERTIFICATE OF DISPOSAL

Chemical Waste Management of the Northwest, Inc., ORD089452353, has received the following waste material:

GENERATOR:	PORT OF TACOMA
MANIFEST #:	011886911JJK
CWM TRACKING ID:	430210-01
PROFILE #:	OR321468
LINE ITEM:	9b.1
QUANTITY:	1 DT
RECEIVED DATE:	11/01/13
DISPOSAL PROCESS(ES):	LANDFILL
FINAL DISPOSAL LOCATION:	LANDFILL 14
DISPOSAL DATE:	11/01/13

I certify, on behalf of the above listed treatment facility, that to the best of my knowledge, the above-described waste material was managed in compliance with all applicable laws, regulations, permits and licenses on the date listed above.

CWMNW RECORDS DEPARTMENT

Date: 11/12/13



WASTE MANAGEMENT
17629 Cedar Springs Lane
Arlington, OR 97812

PORT OF TACOMA
WAD001882984
3400 TAYLOR WAY
TACOMA WA 98421

CERTIFICATE OF DISPOSAL

Chemical Waste Management of the Northwest, Inc., ORD089452353, has received the following waste material:

GENERATOR:	PORT OF TACOMA
MANIFEST #:	011886904JJK
CWM TRACKING ID:	430211-01
PROFILE #:	OR321468
LINE ITEM:	9b.1
QUANTITY:	1 DT
RECEIVED DATE:	11/01/13
DISPOSAL PROCESS(ES):	LANDFILL
FINAL DISPOSAL LOCATION:	LANDFILL 14
DISPOSAL DATE:	11/01/13

I certify, on behalf of the above listed treatment facility, that to the best of my knowledge, the above-described waste material was managed in compliance with all applicable laws, regulations, permits and licenses on the date listed above.

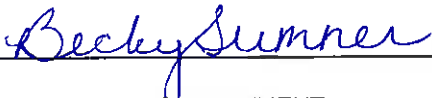

CWMNW RECORDS DEPARTMENT

Date: 11/12/13



WASTE MANAGEMENT
17629 Cedar Springs Lane
Arlington, OR 97812

PORT OF TACOMA
WAD001882984
3400 TAYLOR WAY
TACOMA WA 98421

CERTIFICATE OF DISPOSAL

Chemical Waste Management of the Northwest, Inc., ORD089452353, has received the following waste material:

GENERATOR:	PORT OF TACOMA
MANIFEST #:	011886905JJK
CWM TRACKING ID:	430212-01
PROFILE #:	OR321468
LINE ITEM:	9b.1
QUANTITY:	1 DT
RECEIVED DATE:	11/01/13
DISPOSAL PROCESS(ES):	LANDFILL
FINAL DISPOSAL LOCATION:	LANDFILL 14
DISPOSAL DATE:	11/01/13

I certify, on behalf of the above listed treatment facility, that to the best of my knowledge, the above-described waste material was managed in compliance with all applicable laws, regulations, permits and licenses on the date listed above.

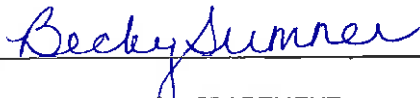

CWMNW RECORDS DEPARTMENT

Date: 11/12/13



WASTE MANAGEMENT

17629 Cedar Springs Lane
Arlington, OR 97812

PORT OF TACOMA
WAD001882984
3400 TAYLOR WAY
TACOMA WA 98421

CERTIFICATE OF DISPOSAL

Chemical Waste Management of the Northwest, Inc., ORD089452353, has received the following waste material:

GENERATOR:	PORT OF TACOMA
MANIFEST #:	011886903JJK
CWM TRACKING ID:	430218-01
PROFILE #:	OR321468
LINE ITEM:	9b.1
QUANTITY:	1 DT
RECEIVED DATE:	11/01/13
DISPOSAL PROCESS(ES):	LANDFILL
FINAL DISPOSAL LOCATION:	LANDFILL 14
DISPOSAL DATE:	11/01/13

I certify, on behalf of the above listed treatment facility, that to the best of my knowledge, the above-described waste material was managed in compliance with all applicable laws, regulations, permits and licenses on the date listed above.

Becky Sumner

CWMNW RECORDS DEPARTMENT

Date: 11/12/13



WASTE MANAGEMENT
17629 Cedar Springs Lane
Arlington, OR 97812

PORT OF TACOMA
WAD001882984
3400 TAYLOR WAY
TACOMA WA 98421

CERTIFICATE OF DISPOSAL

Chemical Waste Management of the Northwest, Inc., ORD089452353, has received the following waste material:

GENERATOR:	PORT OF TACOMA
MANIFEST #:	011886901JJK
CWM TRACKING ID:	430223-01
PROFILE #:	OR321468
LINE ITEM:	9b.1
QUANTITY:	1 DT
RECEIVED DATE:	11/01/13
DISPOSAL PROCESS(ES):	LANDFILL
FINAL DISPOSAL LOCATION:	LANDFILL 14
DISPOSAL DATE:	11/01/13

I certify, on behalf of the above listed treatment facility, that to the best of my knowledge, the above-described waste material was managed in compliance with all applicable laws, regulations, permits and licenses on the date listed above.

CWMNW RECORDS DEPARTMENT

Date: 11/12/13



WASTE MANAGEMENT

17629 Cedar Springs Lane
Arlington, OR 97812

PORT OF TACOMA
WAD001882984
3400 TAYLOR WAY
TACOMA WA 98421

CERTIFICATE OF DISPOSAL

Chemical Waste Management of the Northwest, Inc., ORD089452353, has received the following waste material:

GENERATOR:	PORT OF TACOMA	
MANIFEST #:	011886900JJK	
CWM TRACKING ID:	430224-01	
PROFILE #:	OR321468	
LINE ITEM:	9b.1	
QUANTITY:	1 DT	
RECEIVED DATE:	11/01/13	
DISPOSAL PROCESS(ES):	LANDFILL	
FINAL DISPOSAL LOCATION:	LANDFILL	14
DISPOSAL DATE:	11/01/13	

I certify, on behalf of the above listed treatment facility, that to the best of my knowledge, the above-described waste material was managed in compliance with all applicable laws, regulations, permits and licenses on the date listed above.

Becky Sumner

CWMNW RECORDS DEPARTMENT

Date: 11/12/13





WASTE MANAGEMENT

17629 Cedar Springs Lane
Arlington, OR 97812

PORT OF TACOMA
WAD001882984
3400 TAYLOR WAY
TACOMA WA 98421

CERTIFICATE OF DISPOSAL

Chemical Waste Management of the Northwest, Inc., ORD089452353, has received the following waste material:

GENERATOR:	PORT OF TACOMA
MANIFEST #:	011886898JJK
CWM TRACKING ID:	430225-01
PROFILE #:	OR321468
LINE ITEM:	9b.1
QUANTITY:	1 DT
RECEIVED DATE:	11/01/13
DISPOSAL PROCESS(ES):	LANDFILL
FINAL DISPOSAL LOCATION:	LANDFILL 14
DISPOSAL DATE:	11/01/13

I certify, on behalf of the above listed treatment facility, that to the best of my knowledge, the above-described waste material was managed in compliance with all applicable laws, regulations, permits and licenses on the date listed above.

CWMNW RECORDS DEPARTMENT

Date: 11/12/13



WASTE MANAGEMENT
17629 Cedar Springs Lane
Arlington, OR 97812

PORT OF TACOMA
WAD001882984
3400 TAYLOR WAY
TACOMA WA 98421

CERTIFICATE OF DISPOSAL

Chemical Waste Management of the Northwest, Inc., ORD089452353, has received the following waste material:

GENERATOR:	PORT OF TACOMA
MANIFEST #:	011886897JJK
CWM TRACKING ID:	430226-01
PROFILE #:	OR321468
LINE ITEM:	9b.1
QUANTITY:	1 DT
RECEIVED DATE:	11/01/13
DISPOSAL PROCESS(ES):	LANDFILL
FINAL DISPOSAL LOCATION:	LANDFILL 14
DISPOSAL DATE:	11/01/13

I certify, on behalf of the above listed treatment facility, that to the best of my knowledge, the above-described waste material was managed in compliance with all applicable laws, regulations, permits and licenses on the date listed above.

Becky Sumner

CWMNW RECORDS DEPARTMENT

Date: 11/12/13



WASTE MANAGEMENT
17629 Cedar Springs Lane
Arlington, OR 97812

PORT OF TACOMA
WAD001882984
3400 TAYLOR WAY
TACOMA WA 98421

CERTIFICATE OF DISPOSAL

Chemical Waste Management of the Northwest, Inc., ORD089452353, has received the following waste material:

GENERATOR:	PORT OF TACOMA
MANIFEST #:	011886896JJK
CWM TRACKING ID:	430227-01
PROFILE #:	OR321468
LINE ITEM:	9b.1
QUANTITY:	1 DT
RECEIVED DATE:	11/01/13
DISPOSAL PROCESS(ES):	LANDFILL
FINAL DISPOSAL LOCATION:	LANDFILL 14
DISPOSAL DATE:	11/01/13

I certify, on behalf of the above listed treatment facility, that to the best of my knowledge, the above-described waste material was managed in compliance with all applicable laws, regulations, permits and licenses on the date listed above.

Becky Sumner

CWMNW RECORDS DEPARTMENT

Date: 11/12/13



WASTE MANAGEMENT
17629 Cedar Springs Lane
Arlington, OR 97812

PORT OF TACOMA
WAD001882984
3400 TAYLOR WAY
TACOMA WA 98421

CERTIFICATE OF DISPOSAL

Chemical Waste Management of the Northwest, Inc., ORD089452353, has received the following waste material:

GENERATOR:	PORT OF TACOMA
MANIFEST #:	011886894JJK
CWM TRACKING ID:	430230-01
PROFILE #:	OR321468
LINE ITEM:	9b.1
QUANTITY:	1 DT
RECEIVED DATE:	11/01/13
DISPOSAL PROCESS(ES):	LANDFILL
FINAL DISPOSAL LOCATION:	LANDFILL 14
DISPOSAL DATE:	11/01/13

I certify, on behalf of the above listed treatment facility, that to the best of my knowledge, the above-described waste material was managed in compliance with all applicable laws, regulations, permits and licenses on the date listed above.

CWMNW RECORDS DEPARTMENT

Date: 11/12/13



WASTE MANAGEMENT
17629 Cedar Springs Lane
Arlington, OR 97812

PORT OF TACOMA
WAD001882984
3400 TAYLOR WAY
TACOMA WA 98421

CERTIFICATE OF DISPOSAL

Chemical Waste Management of the Northwest, Inc., ORD089452353, has received the following waste material:

GENERATOR:	PORT OF TACOMA
MANIFEST #:	011886895JJK
CWM TRACKING ID:	430231-01
PROFILE #:	OR321468
LINE ITEM:	9b.1
QUANTITY:	1 DT
RECEIVED DATE:	11/01/13
DISPOSAL PROCESS(ES):	LANDFILL
FINAL DISPOSAL LOCATION:	LANDFILL 14
DISPOSAL DATE:	11/01/13

I certify, on behalf of the above listed treatment facility, that to the best of my knowledge, the above-described waste material was managed in compliance with all applicable laws, regulations, permits and licenses on the date listed above.

Becky Sumner

CWMNW RECORDS DEPARTMENT

Date: 11/12/13



WASTE MANAGEMENT
17629 Cedar Springs Lane
Arlington, OR 97812

PORT OF TACOMA
WAD001882984
3400 TAYLOR WAY
TACOMA WA 98421

CERTIFICATE OF DISPOSAL

Chemical Waste Management of the Northwest, Inc., ORD089452353, has received the following waste material:

GENERATOR:	PORT OF TACOMA
MANIFEST #:	011886893JJK
CWM TRACKING ID:	430232-01
PROFILE #:	OR321468
LINE ITEM:	9b.1
QUANTITY:	1 DT
RECEIVED DATE:	11/01/13
DISPOSAL PROCESS(ES):	LANDFILL
FINAL DISPOSAL LOCATION:	LANDFILL 14
DISPOSAL DATE:	11/01/13

I certify, on behalf of the above listed treatment facility, that to the best of my knowledge, the above-described waste material was managed in compliance with all applicable laws, regulations, permits and licenses on the date listed above.

Becky Sumner

_____ CWMNW RECORDS DEPARTMENT

Date: 11/12/13





WASTE MANAGEMENT
17629 Cedar Springs Lane
Arlington, OR 97812

PORT OF TACOMA
WAD001882984
3400 TAYLOR WAY
TACOMA WA 98421

CERTIFICATE OF DISPOSAL

Chemical Waste Management of the Northwest, Inc., ORD089452353, has received the following waste material:

GENERATOR:	PORT OF TACOMA
MANIFEST #:	011886910JJK
CWM TRACKING ID:	430233-01
PROFILE #:	OR321468
LINE ITEM:	9b.1
QUANTITY:	1 DT
RECEIVED DATE:	11/01/13
DISPOSAL PROCESS(ES):	LANDFILL
FINAL DISPOSAL LOCATION:	LANDFILL 14
DISPOSAL DATE:	11/01/13

I certify, on behalf of the above listed treatment facility, that to the best of my knowledge, the above-described waste material was managed in compliance with all applicable laws, regulations, permits and licenses on the date listed above.

CWMNW RECORDS DEPARTMENT

Date: 11/12/13





WASTE MANAGEMENT
17629 Cedar Springs Lane
Arlington, OR 97812

PORT OF TACOMA
WAD001882984
3400 TAYLOR WAY
TACOMA WA 98421

CERTIFICATE OF DISPOSAL

Chemical Waste Management of the Northwest, Inc., ORD089452353, has received the following waste material:

GENERATOR:	PORT OF TACOMA
MANIFEST #:	011886902JJK
CWM TRACKING ID:	430235-01
PROFILE #:	OR321468
LINE ITEM:	9b.1
QUANTITY:	1 DT
RECEIVED DATE:	11/01/13
DISPOSAL PROCESS(ES):	LANDFILL
FINAL DISPOSAL LOCATION:	LANDFILL 14
DISPOSAL DATE:	11/01/13

I certify, on behalf of the above listed treatment facility, that to the best of my knowledge, the above-described waste material was managed in compliance with all applicable laws, regulations, permits and licenses on the date listed above.

Becky Sumner

CWMNW RECORDS DEPARTMENT

Date: 11/12/13



WASTE MANAGEMENT
17629 Cedar Springs Lane
Arlington, OR 97812

PORT OF TACOMA
WAD001882984
3400 TAYLOR WAY
TACOMA WA 98421

CERTIFICATE OF DISPOSAL

Chemical Waste Management of the Northwest, Inc., ORD089452353, has received the following waste material:

GENERATOR:	PORT OF TACOMA
MANIFEST #:	011886886JJK
CWM TRACKING ID:	430262-01
PROFILE #:	OR321468
LINE ITEM:	9b.1
QUANTITY:	1 DT
RECEIVED DATE:	11/04/13
DISPOSAL PROCESS(ES):	LANDFILL
FINAL DISPOSAL LOCATION:	LANDFILL 14
DISPOSAL DATE:	11/04/13

I certify, on behalf of the above listed treatment facility, that to the best of my knowledge, the above-described waste material was managed in compliance with all applicable laws, regulations, permits and licenses on the date listed above.

Becky Sumner

_____ CWMNW RECORDS DEPARTMENT

Date: 11/12/13



WASTE MANAGEMENT
17629 Cedar Springs Lane
Arlington, OR 97812

PORT OF TACOMA
WAD001882984
3400 TAYLOR WAY
TACOMA WA 98421

CERTIFICATE OF DISPOSAL

Chemical Waste Management of the Northwest, Inc., ORD089452353, has received the following waste material:

GENERATOR:	PORT OF TACOMA
MANIFEST #:	011886892JJK
CWM TRACKING ID:	430263-01
PROFILE #:	OR321468
LINE ITEM:	9b.1
QUANTITY:	1 DT
RECEIVED DATE:	11/04/13
DISPOSAL PROCESS(ES):	LANDFILL
FINAL DISPOSAL LOCATION:	LANDFILL 14
DISPOSAL DATE:	11/04/13

I certify, on behalf of the above listed treatment facility, that to the best of my knowledge, the above-described waste material was managed in compliance with all applicable laws, regulations, permits and licenses on the date listed above.

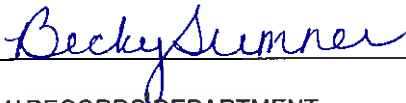

CWMNW RECORDS DEPARTMENT

Date: 11/12/13



WASTE MANAGEMENT
17629 Cedar Springs Lane
Arlington, OR 97812

PORT OF TACOMA
WAD001882984
3400 TAYLOR WAY
TACOMA WA 98421

CERTIFICATE OF DISPOSAL

Chemical Waste Management of the Northwest, Inc., ORD089452353, has received the following waste material:

GENERATOR:	PORT OF TACOMA
MANIFEST #:	011886891JJK
CWM TRACKING ID:	430264-01
PROFILE #:	OR321468
LINE ITEM:	9b.1
QUANTITY:	1 DT
RECEIVED DATE:	11/04/13
DISPOSAL PROCESS(ES):	LANDFILL
FINAL DISPOSAL LOCATION:	LANDFILL 14
DISPOSAL DATE:	11/04/13

I certify, on behalf of the above listed treatment facility, that to the best of my knowledge, the above-described waste material was managed in compliance with all applicable laws, regulations, permits and licenses on the date listed above.

Becky Sumner

CWMNW RECORDS DEPARTMENT

Date: 11/12/13



WASTE MANAGEMENT
17629 Cedar Springs Lane
Arlington, OR 97812

PORT OF TACOMA
WAD001882984
3400 TAYLOR WAY
TACOMA WA 98421

CERTIFICATE OF DISPOSAL

Chemical Waste Management of the Northwest, Inc., ORD089452353, has received the following waste material:

GENERATOR:	PORT OF TACOMA
MANIFEST #:	011886887JJK
CWM TRACKING ID:	430266-01
PROFILE #:	OR321468
LINE ITEM:	9b.1
QUANTITY:	1 DT
RECEIVED DATE:	11/04/13
DISPOSAL PROCESS(ES):	LANDFILL
FINAL DISPOSAL LOCATION:	LANDFILL 14
DISPOSAL DATE:	11/04/13

I certify, on behalf of the above listed treatment facility, that to the best of my knowledge, the above-described waste material was managed in compliance with all applicable laws, regulations, permits and licenses on the date listed above.

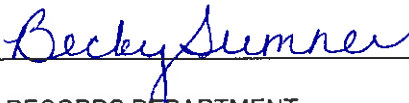

CWMNW RECORDS DEPARTMENT

Date: 11/12/13



WASTE MANAGEMENT
17629 Cedar Springs Lane
Arlington, OR 97812

PORT OF TACOMA
WAD001882984
3400 TAYLOR WAY
TACOMA WA 98421

CERTIFICATE OF DISPOSAL

Chemical Waste Management of the Northwest, Inc., ORD089452353, has received the following waste material:

GENERATOR:	PORT OF TACOMA
MANIFEST #:	011886890JJK
CWM TRACKING ID:	430267-01
PROFILE #:	OR321468
LINE ITEM:	9b.1
QUANTITY:	1 DT
RECEIVED DATE:	11/04/13
DISPOSAL PROCESS(ES):	LANDFILL
FINAL DISPOSAL LOCATION:	LANDFILL 14
DISPOSAL DATE:	11/04/13

I certify, on behalf of the above listed treatment facility, that to the best of my knowledge, the above-described waste material was managed in compliance with all applicable laws, regulations, permits and licenses on the date listed above.

Becky Sumner

_____ CWMNW RECORDS DEPARTMENT

Date: 11/12/13



WASTE MANAGEMENT
17629 Cedar Springs Lane
Arlington, OR 97812

PORT OF TACOMA
WAD001882984
3400 TAYLOR WAY
TACOMA WA 98421

CERTIFICATE OF DISPOSAL

Chemical Waste Management of the Northwest, Inc., ORD089452353, has received the following waste material:

GENERATOR:	PORT OF TACOMA
MANIFEST #:	011886881JJK
CWM TRACKING ID:	430268-01
PROFILE #:	OR321468
LINE ITEM:	9b.1
QUANTITY:	1 DT
RECEIVED DATE:	11/04/13
DISPOSAL PROCESS(ES):	LANDFILL
FINAL DISPOSAL LOCATION:	LANDFILL 14
DISPOSAL DATE:	11/04/13

I certify, on behalf of the above listed treatment facility, that to the best of my knowledge, the above-described waste material was managed in compliance with all applicable laws, regulations, permits and licenses on the date listed above.

Becky Sumner

CWMNW RECORDS DEPARTMENT

Date: 11/12/13



WASTE MANAGEMENT
17629 Cedar Springs Lane
Arlington, OR 97812

PORT OF TACOMA
WAD001882984
3400 TAYLOR WAY
TACOMA WA 98421

CERTIFICATE OF DISPOSAL

Chemical Waste Management of the Northwest, Inc., ORD089452353, has received the following waste material:

GENERATOR:	PORT OF TACOMA
MANIFEST #:	011886885JJK
CWM TRACKING ID:	430270-01
PROFILE #:	OR321468
LINE ITEM:	9b.1
QUANTITY:	1 DT
RECEIVED DATE:	11/04/13
DISPOSAL PROCESS(ES):	LANDFILL
FINAL DISPOSAL LOCATION:	LANDFILL 14
DISPOSAL DATE:	11/04/13

I certify, on behalf of the above listed treatment facility, that to the best of my knowledge, the above-described waste material was managed in compliance with all applicable laws, regulations, permits and licenses on the date listed above.

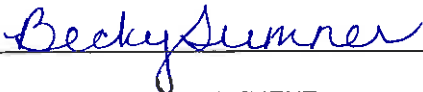

CWMNW RECORDS DEPARTMENT

Date: 11/12/13



WASTE MANAGEMENT
17629 Cedar Springs Lane
Arlington, OR 97812

PORT OF TACOMA
WAD001882984
3400 TAYLOR WAY
TACOMA WA 98421

CERTIFICATE OF DISPOSAL

Chemical Waste Management of the Northwest, Inc., ORD089452353, has received the following waste material:

GENERATOR:	PORT OF TACOMA
MANIFEST #:	011886888JJK
CWM TRACKING ID:	430271-01
PROFILE #:	OR321468
LINE ITEM:	9b.1
QUANTITY:	1 DT
RECEIVED DATE:	11/04/13
DISPOSAL PROCESS(ES):	LANDFILL
FINAL DISPOSAL LOCATION:	LANDFILL 14
DISPOSAL DATE:	11/04/13

I certify, on behalf of the above listed treatment facility, that to the best of my knowledge, the above-described waste material was managed in compliance with all applicable laws, regulations, permits and licenses on the date listed above.

Becky Sumner

CWMNW RECORDS DEPARTMENT

Date: 11/12/13



WASTE MANAGEMENT
17629 Cedar Springs Lane
Arlington, OR 97812

PORT OF TACOMA
WAD001882984
3400 TAYLOR WAY
TACOMA WA 98421

CERTIFICATE OF DISPOSAL

Chemical Waste Management of the Northwest, Inc., ORD089452353, has received the following waste material:

GENERATOR:	PORT OF TACOMA
MANIFEST #:	011886884JJK
CWM TRACKING ID:	430273-01
PROFILE #:	OR321468
LINE ITEM:	9b.1
QUANTITY:	1 DT
RECEIVED DATE:	11/04/13
DISPOSAL PROCESS(ES):	LANDFILL
FINAL DISPOSAL LOCATION:	LANDFILL 14
DISPOSAL DATE:	11/04/13

I certify, on behalf of the above listed treatment facility, that to the best of my knowledge, the above-described waste material was managed in compliance with all applicable laws, regulations, permits and licenses on the date listed above.

Becky Sumner

CWMNW RECORDS DEPARTMENT

Date: 11/12/13



WASTE MANAGEMENT
17629 Cedar Springs Lane
Arlington, OR 97812

PORT OF TACOMA
WAD001882984
3400 TAYLOR WAY
TACOMA WA 98421

CERTIFICATE OF DISPOSAL

Chemical Waste Management of the Northwest, Inc., ORD089452353, has received the following waste material:

GENERATOR:	PORT OF TACOMA
MANIFEST #:	011886889JJK
CWM TRACKING ID:	430276-01
PROFILE #:	OR321468
LINE ITEM:	9b.1
QUANTITY:	1 DT
RECEIVED DATE:	11/04/13
DISPOSAL PROCESS(ES):	LANDFILL
FINAL DISPOSAL LOCATION:	LANDFILL 14
DISPOSAL DATE:	11/04/13

I certify, on behalf of the above listed treatment facility, that to the best of my knowledge, the above-described waste material was managed in compliance with all applicable laws, regulations, permits and licenses on the date listed above.

Becky Sumner

_____ CWMNW RECORDS DEPARTMENT

Date: 11/12/13



WASTE MANAGEMENT
17629 Cedar Springs Lane
Arlington, OR 97812

PORT OF TACOMA
WAD001882984
3400 TAYLOR WAY
TACOMA WA 98421

CERTIFICATE OF DISPOSAL

Chemical Waste Management of the Northwest, Inc., ORD089452353, has received the following waste material:

GENERATOR:	PORT OF TACOMA
MANIFEST #:	011886879JJK
CWM TRACKING ID:	430279-01
PROFILE #:	OR321468
LINE ITEM:	9b.1
QUANTITY:	1 DT
RECEIVED DATE:	11/04/13
DISPOSAL PROCESS(ES):	LANDFILL
FINAL DISPOSAL LOCATION:	LANDFILL 14
DISPOSAL DATE:	11/04/13

I certify, on behalf of the above listed treatment facility, that to the best of my knowledge, the above-described waste material was managed in compliance with all applicable laws, regulations, permits and licenses on the date listed above.

Becky Sumner

CWMNW RECORDS DEPARTMENT

Date: 11/12/13



WASTE MANAGEMENT
17629 Cedar Springs Lane
Arlington, OR 97812

PORT OF TACOMA
WAD001882984
3400 TAYLOR WAY
TACOMA WA 98421

CERTIFICATE OF DISPOSAL

Chemical Waste Management of the Northwest, Inc., ORD089452353, has received the following waste material:

GENERATOR:	PORT OF TACOMA
MANIFEST #:	011886882JJK
CWM TRACKING ID:	430280-01
PROFILE #:	OR321468
LINE ITEM:	9b.1
QUANTITY:	1 DT
RECEIVED DATE:	11/04/13
DISPOSAL PROCESS(ES):	LANDFILL
FINAL DISPOSAL LOCATION:	LANDFILL 14
DISPOSAL DATE:	11/04/13

I certify, on behalf of the above listed treatment facility, that to the best of my knowledge, the above-described waste material was managed in compliance with all applicable laws, regulations, permits and licenses on the date listed above.

CWMNW RECORDS DEPARTMENT

Date: 11/12/13



WASTE MANAGEMENT
17629 Cedar Springs Lane
Arlington, OR 97812

PORT OF TACOMA
WAD001882984
3400 TAYLOR WAY
TACOMA WA 98421

CERTIFICATE OF DISPOSAL

Chemical Waste Management of the Northwest, Inc., ORD089452353, has received the following waste material:

GENERATOR:	PORT OF TACOMA
MANIFEST #:	011886880JJK
CWM TRACKING ID:	430282-01
PROFILE #:	OR321468
LINE ITEM:	9b.1
QUANTITY:	1 DT
RECEIVED DATE:	11/04/13
DISPOSAL PROCESS(ES):	LANDFILL
FINAL DISPOSAL LOCATION:	LANDFILL 14
DISPOSAL DATE:	11/04/13

I certify, on behalf of the above listed treatment facility, that to the best of my knowledge, the above-described waste material was managed in compliance with all applicable laws, regulations, permits and licenses on the date listed above.

Becky Sumner

CWMNW RECORDS DEPARTMENT

Date: 11/12/13



WASTE MANAGEMENT
17629 Cedar Springs Lane
Arlington, OR 97812

PORT OF TACOMA
WAD001882984
3400 TAYLOR WAY
TACOMA WA 98421

CERTIFICATE OF DISPOSAL

Chemical Waste Management of the Northwest, Inc., ORD089452353, has received the following waste material:

GENERATOR:	PORT OF TACOMA
MANIFEST #:	011886877JJK
CWM TRACKING ID:	430287-01
PROFILE #:	OR321468
LINE ITEM:	9b.1
QUANTITY:	1 DT
RECEIVED DATE:	11/04/13
DISPOSAL PROCESS(ES):	LANDFILL
FINAL DISPOSAL LOCATION:	LANDFILL 14
DISPOSAL DATE:	11/04/13

I certify, on behalf of the above listed treatment facility, that to the best of my knowledge, the above-described waste material was managed in compliance with all applicable laws, regulations, permits and licenses on the date listed above.

Becky Sumner

CWMNW RECORDS DEPARTMENT

Date: 11/12/13



WASTE MANAGEMENT
17629 Cedar Springs Lane
Arlington, OR 97812

PORT OF TACOMA
WAD001882984
3400 TAYLOR WAY
TACOMA WA 98421

CERTIFICATE OF DISPOSAL

Chemical Waste Management of the Northwest, Inc., ORD089452353, has received the following waste material:

GENERATOR:	PORT OF TACOMA
MANIFEST #:	011886878JJK
CWM TRACKING ID:	430300-01
PROFILE #:	OR321468
LINE ITEM:	9b.1
QUANTITY:	1 DT
RECEIVED DATE:	11/05/13
DISPOSAL PROCESS(ES):	LANDFILL
FINAL DISPOSAL LOCATION:	LANDFILL 14
DISPOSAL DATE:	11/05/13

I certify, on behalf of the above listed treatment facility, that to the best of my knowledge, the above-described waste material was managed in compliance with all applicable laws, regulations, permits and licenses on the date listed above.

Becky Sumner

_____ CWMNW RECORDS DEPARTMENT

Date: 11/12/13



WASTE MANAGEMENT
17629 Cedar Springs Lane
Arlington, OR 97812

PORT OF TACOMA
WAD001882984
3400 TAYLOR WAY
TACOMA WA 98421

CERTIFICATE OF DISPOSAL

Chemical Waste Management of the Northwest, Inc., ORD089452353, has received the following waste material:

GENERATOR:	PORT OF TACOMA
MANIFEST #:	011886958JJK
CWM TRACKING ID:	430308-01
PROFILE #:	OR321468
LINE ITEM:	9b.1
QUANTITY:	1 DT
RECEIVED DATE:	11/05/13
DISPOSAL PROCESS(ES):	LANDFILL
FINAL DISPOSAL LOCATION:	LANDFILL 14
DISPOSAL DATE:	11/05/13

I certify, on behalf of the above listed treatment facility, that to the best of my knowledge, the above-described waste material was managed in compliance with all applicable laws, regulations, permits and licenses on the date listed above.

Becky Sumner

CWMNW RECORDS DEPARTMENT

Date: 11/12/13



WASTE MANAGEMENT
17629 Cedar Springs Lane
Arlington, OR 97812

PORT OF TACOMA
WAD001882984
3400 TAYLOR WAY
TACOMA WA 98421

CERTIFICATE OF DISPOSAL

Chemical Waste Management of the Northwest, Inc., ORD089452353, has received the following waste material:

GENERATOR:	PORT OF TACOMA
MANIFEST #:	011886867JJK
CWM TRACKING ID:	430330-01
PROFILE #:	OR321468
LINE ITEM:	9b.1
QUANTITY:	1 DT
RECEIVED DATE:	11/05/13
DISPOSAL PROCESS(ES):	LANDFILL
FINAL DISPOSAL LOCATION:	LANDFILL 14
DISPOSAL DATE:	11/05/13

I certify, on behalf of the above listed treatment facility, that to the best of my knowledge, the above-described waste material was managed in compliance with all applicable laws, regulations, permits and licenses on the date listed above.

CWMNW RECORDS DEPARTMENT

Date: 11/12/13



WASTE MANAGEMENT
17629 Cedar Springs Lane
Arlington, OR 97812

PORT OF TACOMA
WAD001882984
3400 TAYLOR WAY
TACOMA WA 98421

CERTIFICATE OF DISPOSAL

Chemical Waste Management of the Northwest, Inc., ORD089452353, has received the following waste material:

GENERATOR:	PORT OF TACOMA
MANIFEST #:	011886866JJK
CWM TRACKING ID:	430331-01
PROFILE #:	OR321468
LINE ITEM:	9b.1
QUANTITY:	1 DT
RECEIVED DATE:	11/05/13
DISPOSAL PROCESS(ES):	LANDFILL
FINAL DISPOSAL LOCATION:	LANDFILL 14
DISPOSAL DATE:	11/05/13

I certify, on behalf of the above listed treatment facility, that to the best of my knowledge, the above-described waste material was managed in compliance with all applicable laws, regulations, permits and licenses on the date listed above.

Becky Sumner

CWMNW RECORDS DEPARTMENT

Date: 11/12/13



WASTE MANAGEMENT
17629 Cedar Springs Lane
Arlington, OR 97812

PORT OF TACOMA
WAD001882984
3400 TAYLOR WAY
TACOMA WA 98421

CERTIFICATE OF DISPOSAL

Chemical Waste Management of the Northwest, Inc., ORD089452353, has received the following waste material:

GENERATOR:	PORT OF TACOMA
MANIFEST #:	011886865JJK
CWM TRACKING ID:	430332-01
PROFILE #:	OR321468
LINE ITEM:	9b.1
QUANTITY:	1 DT
RECEIVED DATE:	11/05/13
DISPOSAL PROCESS(ES):	LANDFILL
FINAL DISPOSAL LOCATION:	LANDFILL 14
DISPOSAL DATE:	11/05/13

I certify, on behalf of the above listed treatment facility, that to the best of my knowledge, the above-described waste material was managed in compliance with all applicable laws, regulations, permits and licenses on the date listed above.

Becky Sumner

_____ CWMNW RECORDS DEPARTMENT

Date: 11/12/13



WASTE MANAGEMENT
17629 Cedar Springs Lane
Arlington, OR 97812

PORT OF TACOMA
WAD001882984
3400 TAYLOR WAY
TACOMA WA 98421

CERTIFICATE OF DISPOSAL

Chemical Waste Management of the Northwest, Inc., ORD089452353, has received the following waste material:

GENERATOR:	PORT OF TACOMA
MANIFEST #:	011886875JJK
CWM TRACKING ID:	430333-01
PROFILE #:	OR321468
LINE ITEM:	9b.1
QUANTITY:	1 DT
RECEIVED DATE:	11/05/13
DISPOSAL PROCESS(ES):	LANDFILL
FINAL DISPOSAL LOCATION:	LANDFILL 14
DISPOSAL DATE:	11/05/13

I certify, on behalf of the above listed treatment facility, that to the best of my knowledge, the above-described waste material was managed in compliance with all applicable laws, regulations, permits and licenses on the date listed above.

Becky Sumner

CWMNW RECORDS DEPARTMENT

Date: 11/12/13



WASTE MANAGEMENT
17629 Cedar Springs Lane
Arlington, OR 97812

PORT OF TACOMA
WAD001882984
3400 TAYLOR WAY
TACOMA WA 98421

CERTIFICATE OF DISPOSAL

Chemical Waste Management of the Northwest, Inc., ORD089452353, has received the following waste material:

GENERATOR:	PORT OF TACOMA
MANIFEST #:	011886872JJK
CWM TRACKING ID:	430334-01
PROFILE #:	OR321468
LINE ITEM:	9b.1
QUANTITY:	1 DT
RECEIVED DATE:	11/05/13
DISPOSAL PROCESS(ES):	LANDFILL
FINAL DISPOSAL LOCATION:	LANDFILL 14
DISPOSAL DATE:	11/05/13

I certify, on behalf of the above listed treatment facility, that to the best of my knowledge, the above-described waste material was managed in compliance with all applicable laws, regulations, permits and licenses on the date listed above.

Becky Sumner

CWMNW RECORDS DEPARTMENT

Date: 11/12/13



WASTE MANAGEMENT
17629 Cedar Springs Lane
Arlington, OR 97812

PORT OF TACOMA
WAD001882984
3400 TAYLOR WAY
TACOMA WA 98421

CERTIFICATE OF DISPOSAL

Chemical Waste Management of the Northwest, Inc., ORD089452353, has received the following waste material:

GENERATOR:	PORT OF TACOMA
MANIFEST #:	011886870JJK
CWM TRACKING ID:	430336-01
PROFILE #:	OR321468
LINE ITEM:	9b.1
QUANTITY:	1 DT
RECEIVED DATE:	11/05/13
DISPOSAL PROCESS(ES):	LANDFILL
FINAL DISPOSAL LOCATION:	LANDFILL 14
DISPOSAL DATE:	11/05/13

I certify, on behalf of the above listed treatment facility, that to the best of my knowledge, the above-described waste material was managed in compliance with all applicable laws, regulations, permits and licenses on the date listed above.

Becky Sumner

CWMNW RECORDS DEPARTMENT

Date: 11/12/13



WASTE MANAGEMENT
17629 Cedar Springs Lane
Arlington, OR 97812

PORT OF TACOMA
WAD001882984
3400 TAYLOR WAY
TACOMA WA 98421

CERTIFICATE OF DISPOSAL

Chemical Waste Management of the Northwest, Inc., ORD089452353, has received the following waste material:

GENERATOR:	PORT OF TACOMA
MANIFEST #:	011886873JJK
CWM TRACKING ID:	430337-01
PROFILE #:	OR321468
LINE ITEM:	9b.1
QUANTITY:	1 DT
RECEIVED DATE:	11/05/13
DISPOSAL PROCESS(ES):	LANDFILL
FINAL DISPOSAL LOCATION:	LANDFILL 14
DISPOSAL DATE:	11/05/13

I certify, on behalf of the above listed treatment facility, that to the best of my knowledge, the above-described waste material was managed in compliance with all applicable laws, regulations, permits and licenses on the date listed above.

Becky Sumner

CWMNW RECORDS DEPARTMENT

Date: 11/12/13



WASTE MANAGEMENT
17629 Cedar Springs Lane
Arlington, OR 97812

PORT OF TACOMA
WAD001882984
3400 TAYLOR WAY
TACOMA WA 98421

CERTIFICATE OF DISPOSAL

Chemical Waste Management of the Northwest, Inc., ORD089452353, has received the following waste material:

GENERATOR:	PORT OF TACOMA
MANIFEST #:	011886874JJK
CWM TRACKING ID:	430338-01
PROFILE #:	OR321468
LINE ITEM:	9b.1
QUANTITY:	1 DT
RECEIVED DATE:	11/05/13
DISPOSAL PROCESS(ES):	LANDFILL
FINAL DISPOSAL LOCATION:	LANDFILL 14
DISPOSAL DATE:	11/05/13

I certify, on behalf of the above listed treatment facility, that to the best of my knowledge, the above-described waste material was managed in compliance with all applicable laws, regulations, permits and licenses on the date listed above.

Becky Sumner

CWMNW RECORDS DEPARTMENT

Date: 11/12/13



WASTE MANAGEMENT
17629 Cedar Springs Lane
Arlington, OR 97812

PORT OF TACOMA
WAD001882984
3400 TAYLOR WAY
TACOMA WA 98421

CERTIFICATE OF DISPOSAL

Chemical Waste Management of the Northwest, Inc., ORD089452353, has received the following waste material:

GENERATOR:	PORT OF TACOMA
MANIFEST #:	011886857JJK
CWM TRACKING ID:	430340-01
PROFILE #:	OR321468
LINE ITEM:	9b.1
QUANTITY:	1 DT
RECEIVED DATE:	11/05/13
DISPOSAL PROCESS(ES):	LANDFILL
FINAL DISPOSAL LOCATION:	LANDFILL 14
DISPOSAL DATE:	11/05/13

I certify, on behalf of the above listed treatment facility, that to the best of my knowledge, the above-described waste material was managed in compliance with all applicable laws, regulations, permits and licenses on the date listed above.

Becky Sumner

_____ CWMNW RECORDS DEPARTMENT

Date: 11/12/13



WASTE MANAGEMENT
17629 Cedar Springs Lane
Arlington, OR 97812

PORT OF TACOMA
WAD001882984
3400 TAYLOR WAY
TACOMA WA 98421

CERTIFICATE OF DISPOSAL

Chemical Waste Management of the Northwest, Inc., ORD089452353, has received the following waste material:

GENERATOR:	PORT OF TACOMA
MANIFEST #:	011886869JJK
CWM TRACKING ID:	430341-01
PROFILE #:	OR321468
LINE ITEM:	9b.1
QUANTITY:	1 DT
RECEIVED DATE:	11/05/13
DISPOSAL PROCESS(ES):	LANDFILL
FINAL DISPOSAL LOCATION:	LANDFILL 14
DISPOSAL DATE:	11/05/13

I certify, on behalf of the above listed treatment facility, that to the best of my knowledge, the above-described waste material was managed in compliance with all applicable laws, regulations, permits and licenses on the date listed above.

CWMNW RECORDS DEPARTMENT

Date: 11/12/13



WASTE MANAGEMENT
17629 Cedar Springs Lane
Arlington, OR 97812

PORT OF TACOMA
WAD001882984
3400 TAYLOR WAY
TACOMA WA 98421

CERTIFICATE OF DISPOSAL

Chemical Waste Management of the Northwest, Inc., ORD089452353, has received the following waste material:

GENERATOR:	PORT OF TACOMA
MANIFEST #:	011886871JJK
CWM TRACKING ID:	430343-01
PROFILE #:	OR321468
LINE ITEM:	9b.1
QUANTITY:	1 DT
RECEIVED DATE:	11/05/13
DISPOSAL PROCESS(ES):	LANDFILL
FINAL DISPOSAL LOCATION:	LANDFILL 14
DISPOSAL DATE:	11/05/13

I certify, on behalf of the above listed treatment facility, that to the best of my knowledge, the above-described waste material was managed in compliance with all applicable laws, regulations, permits and licenses on the date listed above.

CWMNW RECORDS DEPARTMENT

Date: 11/12/13



WASTE MANAGEMENT
17629 Cedar Springs Lane
Arlington, OR 97812

PORT OF TACOMA
WAD001882984
3400 TAYLOR WAY
TACOMA WA 98421

CERTIFICATE OF DISPOSAL

Chemical Waste Management of the Northwest, Inc., ORD089452353, has received the following waste material:

GENERATOR:	PORT OF TACOMA
MANIFEST #:	011886862JJK
CWM TRACKING ID:	430345-01
PROFILE #:	OR321468
LINE ITEM:	9b.1
QUANTITY:	1 DT
RECEIVED DATE:	11/05/13
DISPOSAL PROCESS(ES):	LANDFILL
FINAL DISPOSAL LOCATION:	LANDFILL 14
DISPOSAL DATE:	11/05/13

I certify, on behalf of the above listed treatment facility, that to the best of my knowledge, the above-described waste material was managed in compliance with all applicable laws, regulations, permits and licenses on the date listed above.

CWMNW RECORDS DEPARTMENT

Date: 11/12/13



WASTE MANAGEMENT
17629 Cedar Springs Lane
Arlington, OR 97812

PORT OF TACOMA
WAD001882984
3400 TAYLOR WAY
TACOMA WA 98421

CERTIFICATE OF DISPOSAL

Chemical Waste Management of the Northwest, Inc., ORD089452353, has received the following waste material:

GENERATOR:	PORT OF TACOMA
MANIFEST #:	011886854JJK
CWM TRACKING ID:	430347-01
PROFILE #:	OR321468
LINE ITEM:	9b.1
QUANTITY:	1 DT
RECEIVED DATE:	11/05/13
DISPOSAL PROCESS(ES):	LANDFILL
FINAL DISPOSAL LOCATION:	LANDFILL 14
DISPOSAL DATE:	11/05/13

I certify, on behalf of the above listed treatment facility, that to the best of my knowledge, the above-described waste material was managed in compliance with all applicable laws, regulations, permits and licenses on the date listed above.

CWMNW RECORDS DEPARTMENT

Date: 11/12/13



WASTE MANAGEMENT
17629 Cedar Springs Lane
Arlington, OR 97812

PORT OF TACOMA
WAD001882984
3400 TAYLOR WAY
TACOMA WA 98421

CERTIFICATE OF DISPOSAL

Chemical Waste Management of the Northwest, Inc., ORD089452353, has received the following waste material:

GENERATOR:	PORT OF TACOMA
MANIFEST #:	011886864JJK
CWM TRACKING ID:	430348-01
PROFILE #:	OR321468
LINE ITEM:	9b.1
QUANTITY:	1 DT
RECEIVED DATE:	11/05/13
DISPOSAL PROCESS(ES):	LANDFILL
FINAL DISPOSAL LOCATION:	LANDFILL 14
DISPOSAL DATE:	11/05/13

I certify, on behalf of the above listed treatment facility, that to the best of my knowledge, the above-described waste material was managed in compliance with all applicable laws, regulations, permits and licenses on the date listed above.

CWMNW RECORDS DEPARTMENT

Date: 11/12/13



WASTE MANAGEMENT
17629 Cedar Springs Lane
Arlington, OR 97812

PORT OF TACOMA
WAD001882984
3400 TAYLOR WAY
TACOMA WA 98421

CERTIFICATE OF DISPOSAL

Chemical Waste Management of the Northwest, Inc., ORD089452353, has received the following waste material:

GENERATOR:	PORT OF TACOMA
MANIFEST #:	011886858JJK
CWM TRACKING ID:	430349-01
PROFILE #:	OR321468
LINE ITEM:	9b.1
QUANTITY:	1 DT
RECEIVED DATE:	11/05/13
DISPOSAL PROCESS(ES):	LANDFILL
FINAL DISPOSAL LOCATION:	LANDFILL 14
DISPOSAL DATE:	11/05/13

I certify, on behalf of the above listed treatment facility, that to the best of my knowledge, the above-described waste material was managed in compliance with all applicable laws, regulations, permits and licenses on the date listed above.

Becky Sumner

CWMNW RECORDS DEPARTMENT

Date: 11/12/13



WASTE MANAGEMENT
17629 Cedar Springs Lane
Arlington, OR 97812

PORT OF TACOMA
WAD001882984
3400 TAYLOR WAY
TACOMA WA 98421

CERTIFICATE OF DISPOSAL

Chemical Waste Management of the Northwest, Inc., ORD089452353, has received the following waste material:

GENERATOR:	PORT OF TACOMA
MANIFEST #:	011886856JJK
CWM TRACKING ID:	430350-01
PROFILE #:	OR321468
LINE ITEM:	9b.1
QUANTITY:	1 DT
RECEIVED DATE:	11/05/13
DISPOSAL PROCESS(ES):	LANDFILL
FINAL DISPOSAL LOCATION:	LANDFILL 14
DISPOSAL DATE:	11/05/13

I certify, on behalf of the above listed treatment facility, that to the best of my knowledge, the above-described waste material was managed in compliance with all applicable laws, regulations, permits and licenses on the date listed above.

Becky Sumner

CWMNW RECORDS DEPARTMENT

Date: 11/12/13



WASTE MANAGEMENT
17629 Cedar Springs Lane
Arlington, OR 97812

PORT OF TACOMA
WAD001882984
3400 TAYLOR WAY
TACOMA WA 98421

CERTIFICATE OF DISPOSAL

Chemical Waste Management of the Northwest, Inc., ORD089452353, has received the following waste material:

GENERATOR:	PORT OF TACOMA
MANIFEST #:	011886861JJK
CWM TRACKING ID:	430351-01
PROFILE #:	OR321468
LINE ITEM:	9b.1
QUANTITY:	1 DT
RECEIVED DATE:	11/05/13
DISPOSAL PROCESS(ES):	LANDFILL
FINAL DISPOSAL LOCATION:	LANDFILL 14
DISPOSAL DATE:	11/05/13

I certify, on behalf of the above listed treatment facility, that to the best of my knowledge, the above-described waste material was managed in compliance with all applicable laws, regulations, permits and licenses on the date listed above.

Becky Sumner

_____ CWMNW RECORDS DEPARTMENT

Date: 11/12/13



WASTE MANAGEMENT
17629 Cedar Springs Lane
Arlington, OR 97812

PORT OF TACOMA
WAD001882984
3400 TAYLOR WAY
TACOMA WA 98421

CERTIFICATE OF DISPOSAL

Chemical Waste Management of the Northwest, Inc., ORD089452353, has received the following waste material:

GENERATOR:	PORT OF TACOMA
MANIFEST #:	011886851JJK
CWM TRACKING ID:	430353-01
PROFILE #:	OR321468
LINE ITEM:	9b.1
QUANTITY:	1 DT
RECEIVED DATE:	11/05/13
DISPOSAL PROCESS(ES):	LANDFILL
FINAL DISPOSAL LOCATION:	LANDFILL 14
DISPOSAL DATE:	11/05/13

I certify, on behalf of the above listed treatment facility, that to the best of my knowledge, the above-described waste material was managed in compliance with all applicable laws, regulations, permits and licenses on the date listed above.

Becky Sumner

CWMNW RECORDS DEPARTMENT

Date: 11/12/13



WASTE MANAGEMENT
17629 Cedar Springs Lane
Arlington, OR 97812

PORT OF TACOMA
WAD001882984
3400 TAYLOR WAY
TACOMA WA 98421

CERTIFICATE OF DISPOSAL

Chemical Waste Management of the Northwest, Inc., ORD089452353, has received the following waste material:

GENERATOR:	PORT OF TACOMA
MANIFEST #:	011886863JJK
CWM TRACKING ID:	430354-01
PROFILE #:	OR321468
LINE ITEM:	9b.1
QUANTITY:	1 DT
RECEIVED DATE:	11/05/13
DISPOSAL PROCESS(ES):	LANDFILL
FINAL DISPOSAL LOCATION:	LANDFILL 14
DISPOSAL DATE:	11/05/13

I certify, on behalf of the above listed treatment facility, that to the best of my knowledge, the above-described waste material was managed in compliance with all applicable laws, regulations, permits and licenses on the date listed above.

Becky Sumner

CWMNW RECORDS DEPARTMENT

Date: 11/12/13



WASTE MANAGEMENT
17629 Cedar Springs Lane
Arlington, OR 97812

PORT OF TACOMA
WAD001882984
3400 TAYLOR WAY
TACOMA WA 98421

CERTIFICATE OF DISPOSAL

Chemical Waste Management of the Northwest, Inc., ORD089452353, has received the following waste material:

GENERATOR:	PORT OF TACOMA
MANIFEST #:	011886859JJK
CWM TRACKING ID:	430356-01
PROFILE #:	OR321468
LINE ITEM:	9b.1
QUANTITY:	1 DT
RECEIVED DATE:	11/05/13
DISPOSAL PROCESS(ES):	LANDFILL
FINAL DISPOSAL LOCATION:	LANDFILL 14
DISPOSAL DATE:	11/05/13

I certify, on behalf of the above listed treatment facility, that to the best of my knowledge, the above-described waste material was managed in compliance with all applicable laws, regulations, permits and licenses on the date listed above.

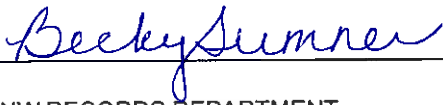

CWMNW RECORDS DEPARTMENT

Date: 11/12/13



WASTE MANAGEMENT
17629 Cedar Springs Lane
Arlington, OR 97812

PORT OF TACOMA
WAD001882984
3400 TAYLOR WAY
TACOMA WA 98421

CERTIFICATE OF DISPOSAL

Chemical Waste Management of the Northwest, Inc., ORD089452353, has received the following waste material:

GENERATOR:	PORT OF TACOMA
MANIFEST #:	011886853JJK
CWM TRACKING ID:	430358-01
PROFILE #:	OR321468
LINE ITEM:	9b.1
QUANTITY:	1 DT
RECEIVED DATE:	11/05/13
DISPOSAL PROCESS(ES):	LANDFILL
FINAL DISPOSAL LOCATION:	LANDFILL 14
DISPOSAL DATE:	11/05/13

I certify, on behalf of the above listed treatment facility, that to the best of my knowledge, the above-described waste material was managed in compliance with all applicable laws, regulations, permits and licenses on the date listed above.

Becky Sumner

CWMNW RECORDS DEPARTMENT

Date: 11/12/13



WASTE MANAGEMENT
17629 Cedar Springs Lane
Arlington, OR 97812

PORT OF TACOMA
WAD001882984
3400 TAYLOR WAY
TACOMA WA 98421

CERTIFICATE OF DISPOSAL

Chemical Waste Management of the Northwest, Inc., ORD089452353, has received the following waste material:

GENERATOR:	PORT OF TACOMA
MANIFEST #:	011886860JJK
CWM TRACKING ID:	430359-01
PROFILE #:	OR321468
LINE ITEM:	9b.1
QUANTITY:	1 DT
RECEIVED DATE:	11/05/13
DISPOSAL PROCESS(ES):	LANDFILL
FINAL DISPOSAL LOCATION:	LANDFILL 14
DISPOSAL DATE:	11/05/13

I certify, on behalf of the above listed treatment facility, that to the best of my knowledge, the above-described waste material was managed in compliance with all applicable laws, regulations, permits and licenses on the date listed above.

Becky Sumner

CWMNW RECORDS DEPARTMENT

Date: 11/12/13



WASTE MANAGEMENT
17629 Cedar Springs Lane
Arlington, OR 97812

PORT OF TACOMA
WAD001882984
3400 TAYLOR WAY
TACOMA WA 98421

CERTIFICATE OF DISPOSAL

Chemical Waste Management of the Northwest, Inc., ORD089452353, has received the following waste material:

GENERATOR:	PORT OF TACOMA
MANIFEST #:	011886855JJK
CWM TRACKING ID:	430360-01
PROFILE #:	OR321468
LINE ITEM:	9b.1
QUANTITY:	1 DT
RECEIVED DATE:	11/05/13
DISPOSAL PROCESS(ES):	LANDFILL
FINAL DISPOSAL LOCATION:	LANDFILL 14
DISPOSAL DATE:	11/05/13

I certify, on behalf of the above listed treatment facility, that to the best of my knowledge, the above-described waste material was managed in compliance with all applicable laws, regulations, permits and licenses on the date listed above.

Becky Sumner

CWMNW RECORDS DEPARTMENT

Date: 11/12/13



WASTE MANAGEMENT
17629 Cedar Springs Lane
Arlington, OR 97812

PORT OF TACOMA
WAD001882984
3400 TAYLOR WAY
TACOMA WA 98421

CERTIFICATE OF DISPOSAL

Chemical Waste Management of the Northwest, Inc., ORD089452353, has received the following waste material:

GENERATOR:	PORT OF TACOMA
MANIFEST #:	011886852JJK
CWM TRACKING ID:	430361-01
PROFILE #:	OR321468
LINE ITEM:	9b.1
QUANTITY:	1 DT
RECEIVED DATE:	11/05/13
DISPOSAL PROCESS(ES):	LANDFILL
FINAL DISPOSAL LOCATION:	LANDFILL 14
DISPOSAL DATE:	11/05/13

I certify, on behalf of the above listed treatment facility, that to the best of my knowledge, the above-described waste material was managed in compliance with all applicable laws, regulations, permits and licenses on the date listed above.

Becky Sumner

CWMNW RECORDS DEPARTMENT

Date: 11/12/13



WASTE MANAGEMENT
17629 Cedar Springs Lane
Arlington, OR 97812

PORT OF TACOMA
WAD001882984
3400 TAYLOR WAY
TACOMA WA 98421

CERTIFICATE OF DISPOSAL

Chemical Waste Management of the Northwest, Inc., ORD089452353, has received the following waste material:

GENERATOR:	PORT OF TACOMA
MANIFEST #:	011886845JJK
CWM TRACKING ID:	430365-01
PROFILE #:	OR321468
LINE ITEM:	9b.1
QUANTITY:	1 DT
RECEIVED DATE:	11/05/13
DISPOSAL PROCESS(ES):	LANDFILL
FINAL DISPOSAL LOCATION:	LANDFILL 14
DISPOSAL DATE:	11/05/13

I certify, on behalf of the above listed treatment facility, that to the best of my knowledge, the above-described waste material was managed in compliance with all applicable laws, regulations, permits and licenses on the date listed above.

Becky Sumner

CWMNW RECORDS DEPARTMENT

Date: 11/12/13



WASTE MANAGEMENT
17629 Cedar Springs Lane
Arlington, OR 97812

PORT OF TACOMA
WAD001882984
3400 TAYLOR WAY
TACOMA WA 98421

CERTIFICATE OF DISPOSAL

Chemical Waste Management of the Northwest, Inc., ORD089452353, has received the following waste material:

GENERATOR:	PORT OF TACOMA
MANIFEST #:	011886846JJK
CWM TRACKING ID:	430368-01
PROFILE #:	OR321468
LINE ITEM:	9b.1
QUANTITY:	1 DT
RECEIVED DATE:	11/05/13
DISPOSAL PROCESS(ES):	LANDFILL
FINAL DISPOSAL LOCATION:	LANDFILL 14
DISPOSAL DATE:	11/05/13

I certify, on behalf of the above listed treatment facility, that to the best of my knowledge, the above-described waste material was managed in compliance with all applicable laws, regulations, permits and licenses on the date listed above.

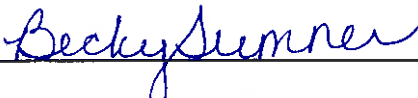

CWMNW RECORDS DEPARTMENT

Date: 11/12/13



WASTE MANAGEMENT
17629 Cedar Springs Lane
Arlington, OR 97812

PORT OF TACOMA
WAD001882984
3400 TAYLOR WAY
TACOMA WA 98421

CERTIFICATE OF DISPOSAL

Chemical Waste Management of the Northwest, Inc., ORD089452353, has received the following waste material:

GENERATOR:	PORT OF TACOMA
MANIFEST #:	011886848JJK
CWM TRACKING ID:	430369-01
PROFILE #:	OR321468
LINE ITEM:	9b.1
QUANTITY:	1 DT
RECEIVED DATE:	11/05/13
DISPOSAL PROCESS(ES):	LANDFILL
FINAL DISPOSAL LOCATION:	LANDFILL 14
DISPOSAL DATE:	11/05/13

I certify, on behalf of the above listed treatment facility, that to the best of my knowledge, the above-described waste material was managed in compliance with all applicable laws, regulations, permits and licenses on the date listed above.

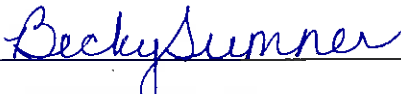

CWMNW RECORDS DEPARTMENT

Date: 11/12/13



WASTE MANAGEMENT
17629 Cedar Springs Lane
Arlington, OR 97812

PORT OF TACOMA
WAD001882984
3400 TAYLOR WAY
TACOMA WA 98421

CERTIFICATE OF DISPOSAL

Chemical Waste Management of the Northwest, Inc., ORD089452353, has received the following waste material:

GENERATOR:	PORT OF TACOMA
MANIFEST #:	011886876FLE
CWM TRACKING ID:	430298-01
PROFILE #:	OR321468
LINE ITEM:	9b.1
QUANTITY:	1 DT
RECEIVED DATE:	11/05/13
DISPOSAL PROCESS(ES):	LANDFILL
FINAL DISPOSAL LOCATION:	LANDFILL 14
DISPOSAL DATE:	11/05/13

I certify, on behalf of the above listed treatment facility, that to the best of my knowledge, the above-described waste material was managed in compliance with all applicable laws, regulations, permits and licenses on the date listed above.

Becky Sumner

CWMNW RECORDS DEPARTMENT

Date: 11/12/13



WASTE MANAGEMENT
17629 Cedar Springs Lane
Arlington, OR 97812

PORT OF TACOMA
WAD001882984
3400 TAYLOR WAY
TACOMA WA 98421

CERTIFICATE OF DISPOSAL

Chemical Waste Management of the Northwest, Inc., ORD089452353, has received the following waste material:

GENERATOR:	PORT OF TACOMA
MANIFEST #:	011886843JJK
CWM TRACKING ID:	430401-01
PROFILE #:	OR321468
LINE ITEM:	9b.1
QUANTITY:	1 DT
RECEIVED DATE:	11/06/13
DISPOSAL PROCESS(ES):	LANDFILL
FINAL DISPOSAL LOCATION:	LANDFILL 14
DISPOSAL DATE:	11/06/13

I certify, on behalf of the above listed treatment facility, that to the best of my knowledge, the above-described waste material was managed in compliance with all applicable laws, regulations, permits and licenses on the date listed above.

CWMNW RECORDS DEPARTMENT

Date: 11/12/13



WASTE MANAGEMENT
17629 Cedar Springs Lane
Arlington, OR 97812

PORT OF TACOMA
WAD001882984
3400 TAYLOR WAY
TACOMA WA 98421

CERTIFICATE OF DISPOSAL

Chemical Waste Management of the Northwest, Inc., ORD089452353, has received the following waste material:

GENERATOR:	PORT OF TACOMA
MANIFEST #:	011886844JJK
CWM TRACKING ID:	430402-01
PROFILE #:	OR321468
LINE ITEM:	9b.1
QUANTITY:	1 DT
RECEIVED DATE:	11/06/13
DISPOSAL PROCESS(ES):	LANDFILL
FINAL DISPOSAL LOCATION:	LANDFILL 14
DISPOSAL DATE:	11/06/13

I certify, on behalf of the above listed treatment facility, that to the best of my knowledge, the above-described waste material was managed in compliance with all applicable laws, regulations, permits and licenses on the date listed above.

CWMNW RECORDS DEPARTMENT

Date: 11/12/13



WASTE MANAGEMENT
17629 Cedar Springs Lane
Arlington, OR 97812

PORT OF TACOMA
WAD001882984
3400 TAYLOR WAY
TACOMA WA 98421

CERTIFICATE OF DISPOSAL

Chemical Waste Management of the Northwest, Inc., ORD089452353, has received the following waste material:

GENERATOR:	PORT OF TACOMA
MANIFEST #:	011886842JJK
CWM TRACKING ID:	430403-01
PROFILE #:	OR321468
LINE ITEM:	9b.1
QUANTITY:	1 DT
RECEIVED DATE:	11/06/13
DISPOSAL PROCESS(ES):	LANDFILL
FINAL DISPOSAL LOCATION:	LANDFILL 14
DISPOSAL DATE:	11/06/13

I certify, on behalf of the above listed treatment facility, that to the best of my knowledge, the above-described waste material was managed in compliance with all applicable laws, regulations, permits and licenses on the date listed above.

Becky Sumner

CWMNW RECORDS DEPARTMENT

Date: 11/12/13



WASTE MANAGEMENT
17629 Cedar Springs Lane
Arlington, OR 97812

PORT OF TACOMA
WAD001882984
3400 TAYLOR WAY
TACOMA WA 98421

CERTIFICATE OF DISPOSAL

Chemical Waste Management of the Northwest, Inc., ORD089452353, has received the following waste material:

GENERATOR:	PORT OF TACOMA
MANIFEST #:	011886841JJK
CWM TRACKING ID:	430404-01
PROFILE #:	OR321468
LINE ITEM:	9b.1
QUANTITY:	1 DT
RECEIVED DATE:	11/06/13
DISPOSAL PROCESS(ES):	LANDFILL
FINAL DISPOSAL LOCATION:	LANDFILL 14
DISPOSAL DATE:	11/06/13

I certify, on behalf of the above listed treatment facility, that to the best of my knowledge, the above-described waste material was managed in compliance with all applicable laws, regulations, permits and licenses on the date listed above.

Becky Sumner

CWMNW RECORDS DEPARTMENT

Date: 11/12/13



WASTE MANAGEMENT
17629 Cedar Springs Lane
Arlington, OR 97812

PORT OF TACOMA
WAD001882984
3400 TAYLOR WAY
TACOMA WA 98421

CERTIFICATE OF DISPOSAL

Chemical Waste Management of the Northwest, Inc., ORD089452353, has received the following waste material:

GENERATOR:	PORT OF TACOMA
MANIFEST #:	011886839JJK
CWM TRACKING ID:	430405-01
PROFILE #:	OR321468
LINE ITEM:	9b.1
QUANTITY:	1 DT
RECEIVED DATE:	11/06/13
DISPOSAL PROCESS(ES):	LANDFILL
FINAL DISPOSAL LOCATION:	LANDFILL 14
DISPOSAL DATE:	11/06/13

I certify, on behalf of the above listed treatment facility, that to the best of my knowledge, the above-described waste material was managed in compliance with all applicable laws, regulations, permits and licenses on the date listed above.

Becky Sumner

CWMNW RECORDS DEPARTMENT

Date: 11/12/13



WASTE MANAGEMENT
17629 Cedar Springs Lane
Arlington, OR 97812

PORT OF TACOMA
WAD001882984
3400 TAYLOR WAY
TACOMA WA 98421

CERTIFICATE OF DISPOSAL

Chemical Waste Management of the Northwest, Inc., ORD089452353, has received the following waste material:

GENERATOR:	PORT OF TACOMA
MANIFEST #:	011886838JJK
CWM TRACKING ID:	430406-01
PROFILE #:	OR321468
LINE ITEM:	9b.1
QUANTITY:	1 DT
RECEIVED DATE:	11/06/13
DISPOSAL PROCESS(ES):	LANDFILL
FINAL DISPOSAL LOCATION:	LANDFILL 14
DISPOSAL DATE:	11/06/13

I certify, on behalf of the above listed treatment facility, that to the best of my knowledge, the above-described waste material was managed in compliance with all applicable laws, regulations, permits and licenses on the date listed above.

CWMNW RECORDS DEPARTMENT

Date: 11/12/13





WASTE MANAGEMENT
17629 Cedar Springs Lane
Arlington, OR 97812

PORT OF TACOMA
WAD001882984
3400 TAYLOR WAY
TACOMA WA 98421

CERTIFICATE OF DISPOSAL

Chemical Waste Management of the Northwest, Inc., ORD089452353, has received the following waste material:

GENERATOR:	PORT OF TACOMA
MANIFEST #:	011886840JJK
CWM TRACKING ID:	430407-01
PROFILE #:	OR321468
LINE ITEM:	9b.1
QUANTITY:	1 DT
RECEIVED DATE:	11/06/13
DISPOSAL PROCESS(ES):	LANDFILL
FINAL DISPOSAL LOCATION:	LANDFILL 14
DISPOSAL DATE:	11/06/13

I certify, on behalf of the above listed treatment facility, that to the best of my knowledge, the above-described waste material was managed in compliance with all applicable laws, regulations, permits and licenses on the date listed above.

CWMNW RECORDS DEPARTMENT

Date: 11/12/13



WASTE MANAGEMENT
17629 Cedar Springs Lane
Arlington, OR 97812

PORT OF TACOMA
WAD001882984
3400 TAYLOR WAY
TACOMA WA 98421

CERTIFICATE OF DISPOSAL

Chemical Waste Management of the Northwest, Inc., ORD089452353, has received the following waste material:

GENERATOR:	PORT OF TACOMA
MANIFEST #:	011886850JJK
CWM TRACKING ID:	430408-01
PROFILE #:	OR321468
LINE ITEM:	9b.1
QUANTITY:	1 DT
RECEIVED DATE:	11/06/13
DISPOSAL PROCESS(ES):	LANDFILL
FINAL DISPOSAL LOCATION:	LANDFILL 14
DISPOSAL DATE:	11/06/13

I certify, on behalf of the above listed treatment facility, that to the best of my knowledge, the above-described waste material was managed in compliance with all applicable laws, regulations, permits and licenses on the date listed above.

Becky Sumner

CWMNW RECORDS DEPARTMENT

Date: 11/12/13



WASTE MANAGEMENT
17629 Cedar Springs Lane
Arlington, OR 97812

PORT OF TACOMA
WAD001882984
3400 TAYLOR WAY
TACOMA WA 98421

CERTIFICATE OF DISPOSAL

Chemical Waste Management of the Northwest, Inc., ORD089452353, has received the following waste material:

GENERATOR:	PORT OF TACOMA
MANIFEST #:	011886831JJK
CWM TRACKING ID:	430411-01
PROFILE #:	OR321468
LINE ITEM:	9b.1
QUANTITY:	1 DT
RECEIVED DATE:	11/06/13
DISPOSAL PROCESS(ES):	LANDFILL
FINAL DISPOSAL LOCATION:	LANDFILL 14
DISPOSAL DATE:	11/06/13

I certify, on behalf of the above listed treatment facility, that to the best of my knowledge, the above-described waste material was managed in compliance with all applicable laws, regulations, permits and licenses on the date listed above.

Becky Sumner

CWMNW RECORDS DEPARTMENT

Date: 11/12/13



WASTE MANAGEMENT
17629 Cedar Springs Lane
Arlington, OR 97812

PORT OF TACOMA
WAD001882984
3400 TAYLOR WAY
TACOMA WA 98421

CERTIFICATE OF DISPOSAL

Chemical Waste Management of the Northwest, Inc., ORD089452353, has received the following waste material:

GENERATOR:	PORT OF TACOMA
MANIFEST #:	011886836JJK
CWM TRACKING ID:	430412-01
PROFILE #:	OR321468
LINE ITEM:	9b.1
QUANTITY:	1 DT
RECEIVED DATE:	11/06/13
DISPOSAL PROCESS(ES):	LANDFILL
FINAL DISPOSAL LOCATION:	LANDFILL 14
DISPOSAL DATE:	11/06/13

I certify, on behalf of the above listed treatment facility, that to the best of my knowledge, the above-described waste material was managed in compliance with all applicable laws, regulations, permits and licenses on the date listed above.

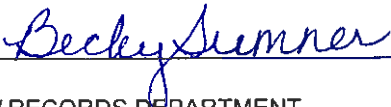

CWMNW RECORDS DEPARTMENT

Date: 11/12/13



WASTE MANAGEMENT
17629 Cedar Springs Lane
Arlington, OR 97812

PORT OF TACOMA
WAD001882984
3400 TAYLOR WAY
TACOMA WA 98421

CERTIFICATE OF DISPOSAL

Chemical Waste Management of the Northwest, Inc., ORD089452353, has received the following waste material:

GENERATOR:	PORT OF TACOMA
MANIFEST #:	011886837JJK
CWM TRACKING ID:	430415-01
PROFILE #:	OR321468
LINE ITEM:	9b.1
QUANTITY:	1 DT
RECEIVED DATE:	11/06/13
DISPOSAL PROCESS(ES):	LANDFILL
FINAL DISPOSAL LOCATION:	LANDFILL 14
DISPOSAL DATE:	11/06/13

I certify, on behalf of the above listed treatment facility, that to the best of my knowledge, the above-described waste material was managed in compliance with all applicable laws, regulations, permits and licenses on the date listed above.

Becky Sumner

CWMNW RECORDS DEPARTMENT

Date: 11/12/13



WASTE MANAGEMENT
17629 Cedar Springs Lane
Arlington, OR 97812

PORT OF TACOMA
WAD001882984
3400 TAYLOR WAY
TACOMA WA 98421

CERTIFICATE OF DISPOSAL

Chemical Waste Management of the Northwest, Inc., ORD089452353, has received the following waste material:

GENERATOR:	PORT OF TACOMA
MANIFEST #:	011886834JJK
CWM TRACKING ID:	430418-01
PROFILE #:	OR321468
LINE ITEM:	9b.1
QUANTITY:	1 DT
RECEIVED DATE:	11/06/13
DISPOSAL PROCESS(ES):	LANDFILL
FINAL DISPOSAL LOCATION:	LANDFILL 14
DISPOSAL DATE:	11/06/13

I certify, on behalf of the above listed treatment facility, that to the best of my knowledge, the above-described waste material was managed in compliance with all applicable laws, regulations, permits and licenses on the date listed above.

CWMNW RECORDS DEPARTMENT

Date: 11/12/13



WASTE MANAGEMENT
17629 Cedar Springs Lane
Arlington, OR 97812

PORT OF TACOMA
WAD001882984
3400 TAYLOR WAY
TACOMA WA 98421

CERTIFICATE OF DISPOSAL

Chemical Waste Management of the Northwest, Inc., ORD089452353, has received the following waste material:

GENERATOR:	PORT OF TACOMA
MANIFEST #:	011886835JJK
CWM TRACKING ID:	430419-01
PROFILE #:	OR321468
LINE ITEM:	9b.1
QUANTITY:	1 DT
RECEIVED DATE:	11/06/13
DISPOSAL PROCESS(ES):	LANDFILL
FINAL DISPOSAL LOCATION:	LANDFILL 14
DISPOSAL DATE:	11/06/13

I certify, on behalf of the above listed treatment facility, that to the best of my knowledge, the above-described waste material was managed in compliance with all applicable laws, regulations, permits and licenses on the date listed above.

CWMNW RECORDS DEPARTMENT

Date: 11/12/13



WASTE MANAGEMENT
17629 Cedar Springs Lane
Arlington, OR 97812

PORT OF TACOMA
WAD001882984
3400 TAYLOR WAY
TACOMA WA 98421

CERTIFICATE OF DISPOSAL

Chemical Waste Management of the Northwest, Inc., ORD089452353, has received the following waste material:

GENERATOR:	PORT OF TACOMA
MANIFEST #:	011886832JJK
CWM TRACKING ID:	430420-01
PROFILE #:	OR321468
LINE ITEM:	9b.1
QUANTITY:	1 DT
RECEIVED DATE:	11/06/13
DISPOSAL PROCESS(ES):	LANDFILL
FINAL DISPOSAL LOCATION:	LANDFILL 14
DISPOSAL DATE:	11/06/13

I certify, on behalf of the above listed treatment facility, that to the best of my knowledge, the above-described waste material was managed in compliance with all applicable laws, regulations, permits and licenses on the date listed above.

Becky Sumner

_____ CWMNW RECORDS DEPARTMENT

Date: 11/12/13



WASTE MANAGEMENT
17629 Cedar Springs Lane
Arlington, OR 97812

PORT OF TACOMA
WAD001882984
3400 TAYLOR WAY
TACOMA WA 98421

CERTIFICATE OF DISPOSAL

Chemical Waste Management of the Northwest, Inc., ORD089452353, has received the following waste material:

GENERATOR:	PORT OF TACOMA
MANIFEST #:	011886849JJK
CWM TRACKING ID:	430421-01
PROFILE #:	OR321468
LINE ITEM:	9b.1
QUANTITY:	1 DT
RECEIVED DATE:	11/06/13
DISPOSAL PROCESS(ES):	LANDFILL
FINAL DISPOSAL LOCATION:	LANDFILL 14
DISPOSAL DATE:	11/06/13

I certify, on behalf of the above listed treatment facility, that to the best of my knowledge, the above-described waste material was managed in compliance with all applicable laws, regulations, permits and licenses on the date listed above.

CWMNW RECORDS DEPARTMENT

Date: 11/12/13



WASTE MANAGEMENT
17629 Cedar Springs Lane
Arlington, OR 97812

PORT OF TACOMA
WAD001882984
3400 TAYLOR WAY
TACOMA WA 98421

CERTIFICATE OF DISPOSAL

Chemical Waste Management of the Northwest, Inc., ORD089452353, has received the following waste material:

GENERATOR:	PORT OF TACOMA
MANIFEST #:	011886833JJK
CWM TRACKING ID:	430422-01
PROFILE #:	OR321468
LINE ITEM:	9b.1
QUANTITY:	1 DT
RECEIVED DATE:	11/06/13
DISPOSAL PROCESS(ES):	LANDFILL
FINAL DISPOSAL LOCATION:	LANDFILL 14
DISPOSAL DATE:	11/06/13

I certify, on behalf of the above listed treatment facility, that to the best of my knowledge, the above-described waste material was managed in compliance with all applicable laws, regulations, permits and licenses on the date listed above.

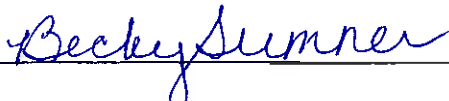

CWMNW RECORDS DEPARTMENT

Date: 11/12/13



WASTE MANAGEMENT
17629 Cedar Springs Lane
Arlington, OR 97812

PORT OF TACOMA
WAD001882984
3400 TAYLOR WAY
TACOMA WA 98421

CERTIFICATE OF DISPOSAL

Chemical Waste Management of the Northwest, Inc., ORD089452353, has received the following waste material:

GENERATOR:	PORT OF TACOMA
MANIFEST #:	011886830JJK
CWM TRACKING ID:	430424-01
PROFILE #:	OR321468
LINE ITEM:	9b.1
QUANTITY:	1 DT
RECEIVED DATE:	11/06/13
DISPOSAL PROCESS(ES):	LANDFILL
FINAL DISPOSAL LOCATION:	LANDFILL 14
DISPOSAL DATE:	11/06/13

I certify, on behalf of the above listed treatment facility, that to the best of my knowledge, the above-described waste material was managed in compliance with all applicable laws, regulations, permits and licenses on the date listed above.

CWMNW RECORDS DEPARTMENT

Date: 11/12/13



WASTE MANAGEMENT
17629 Cedar Springs Lane
Arlington, OR 97812

PORT OF TACOMA
WAD001882984
3400 TAYLOR WAY
TACOMA WA 98421

CERTIFICATE OF DISPOSAL

Chemical Waste Management of the Northwest, Inc., ORD089452353, has received the following waste material:

GENERATOR:	PORT OF TACOMA
MANIFEST #:	011886829JJK
CWM TRACKING ID:	430425-01
PROFILE #:	OR321468
LINE ITEM:	9b.1
QUANTITY:	1 DT
RECEIVED DATE:	11/06/13
DISPOSAL PROCESS(ES):	LANDFILL
FINAL DISPOSAL LOCATION:	LANDFILL 14
DISPOSAL DATE:	11/06/13

I certify, on behalf of the above listed treatment facility, that to the best of my knowledge, the above-described waste material was managed in compliance with all applicable laws, regulations, permits and licenses on the date listed above.

Becky Sumner

CWMNW RECORDS DEPARTMENT

Date: 11/12/13



WASTE MANAGEMENT
17629 Cedar Springs Lane
Arlington, OR 97812

PORT OF TACOMA
WAD001882984
3400 TAYLOR WAY
TACOMA WA 98421

CERTIFICATE OF DISPOSAL

Chemical Waste Management of the Northwest, Inc., ORD089452353, has received the following waste material:

GENERATOR:	PORT OF TACOMA
MANIFEST #:	011886824JJK
CWM TRACKING ID:	430426-01
PROFILE #:	OR321468
LINE ITEM:	9b.1
QUANTITY:	1 DT
RECEIVED DATE:	11/06/13
DISPOSAL PROCESS(ES):	LANDFILL
FINAL DISPOSAL LOCATION:	LANDFILL 14
DISPOSAL DATE:	11/06/13

I certify, on behalf of the above listed treatment facility, that to the best of my knowledge, the above-described waste material was managed in compliance with all applicable laws, regulations, permits and licenses on the date listed above.

Becky Sumner

CWMNW RECORDS DEPARTMENT

Date: 11/12/13



WASTE MANAGEMENT
17629 Cedar Springs Lane
Arlington, OR 97812

PORT OF TACOMA
WAD001882984
3400 TAYLOR WAY
TACOMA WA 98421

CERTIFICATE OF DISPOSAL

Chemical Waste Management of the Northwest, Inc., ORD089452353, has received the following waste material:

GENERATOR:	PORT OF TACOMA
MANIFEST #:	011886823JJK
CWM TRACKING ID:	430427-01
PROFILE #:	OR321468
LINE ITEM:	9b.1
QUANTITY:	1 DT
RECEIVED DATE:	11/06/13
DISPOSAL PROCESS(ES):	LANDFILL
FINAL DISPOSAL LOCATION:	LANDFILL 14
DISPOSAL DATE:	11/06/13

I certify, on behalf of the above listed treatment facility, that to the best of my knowledge, the above-described waste material was managed in compliance with all applicable laws, regulations, permits and licenses on the date listed above.

Becky Sumner

_____ CWMNW RECORDS DEPARTMENT

Date: 11/12/13



WASTE MANAGEMENT
17629 Cedar Springs Lane
Arlington, OR 97812

PORT OF TACOMA
WAD001882984
3400 TAYLOR WAY
TACOMA WA 98421

CERTIFICATE OF DISPOSAL

Chemical Waste Management of the Northwest, Inc., ORD089452353, has received the following waste material:

GENERATOR:	PORT OF TACOMA
MANIFEST #:	011886828JJK
CWM TRACKING ID:	430428-01
PROFILE #:	OR321468
LINE ITEM:	9b.1
QUANTITY:	1 DT
RECEIVED DATE:	11/06/13
DISPOSAL PROCESS(ES):	LANDFILL
FINAL DISPOSAL LOCATION:	LANDFILL 14
DISPOSAL DATE:	11/06/13

I certify, on behalf of the above listed treatment facility, that to the best of my knowledge, the above-described waste material was managed in compliance with all applicable laws, regulations, permits and licenses on the date listed above.

Becky Sumner

CWMNW RECORDS DEPARTMENT

Date: 11/12/13



WASTE MANAGEMENT
17629 Cedar Springs Lane
Arlington, OR 97812

PORT OF TACOMA
WAD001882984
3400 TAYLOR WAY
TACOMA WA 98421

CERTIFICATE OF DISPOSAL

Chemical Waste Management of the Northwest, Inc., ORD089452353, has received the following waste material:

GENERATOR:	PORT OF TACOMA
MANIFEST #:	011886820JJK
CWM TRACKING ID:	430434-01
PROFILE #:	OR321468
LINE ITEM:	9b.1
QUANTITY:	1 DT
RECEIVED DATE:	11/06/13
DISPOSAL PROCESS(ES):	LANDFILL
FINAL DISPOSAL LOCATION:	LANDFILL 14
DISPOSAL DATE:	11/06/13

I certify, on behalf of the above listed treatment facility, that to the best of my knowledge, the above-described waste material was managed in compliance with all applicable laws, regulations, permits and licenses on the date listed above.

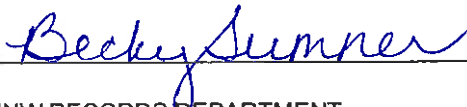

CWMNW RECORDS DEPARTMENT

Date: 11/12/13



WASTE MANAGEMENT
17629 Cedar Springs Lane
Arlington, OR 97812

PORT OF TACOMA
WAD001882984
3400 TAYLOR WAY
TACOMA WA 98421

CERTIFICATE OF DISPOSAL

Chemical Waste Management of the Northwest, Inc., ORD089452353, has received the following waste material:

GENERATOR:	PORT OF TACOMA
MANIFEST #:	011886821JJK
CWM TRACKING ID:	430435-01
PROFILE #:	OR321468
LINE ITEM:	9b.1
QUANTITY:	1 DT
RECEIVED DATE:	11/06/13
DISPOSAL PROCESS(ES):	LANDFILL
FINAL DISPOSAL LOCATION:	LANDFILL 14
DISPOSAL DATE:	11/06/13

I certify, on behalf of the above listed treatment facility, that to the best of my knowledge, the above-described waste material was managed in compliance with all applicable laws, regulations, permits and licenses on the date listed above.

CWMNW RECORDS DEPARTMENT

Date: 11/12/13



WASTE MANAGEMENT
17629 Cedar Springs Lane
Arlington, OR 97812

PORT OF TACOMA
WAD001882984
3400 TAYLOR WAY
TACOMA WA 98421

CERTIFICATE OF DISPOSAL

Chemical Waste Management of the Northwest, Inc., ORD089452353, has received the following waste material:

GENERATOR:	PORT OF TACOMA
MANIFEST #:	011886826JJK
CWM TRACKING ID:	430436-01
PROFILE #:	OR321468
LINE ITEM:	9b.1
QUANTITY:	1 DT
RECEIVED DATE:	11/06/13
DISPOSAL PROCESS(ES):	LANDFILL
FINAL DISPOSAL LOCATION:	LANDFILL 14
DISPOSAL DATE:	11/06/13

I certify, on behalf of the above listed treatment facility, that to the best of my knowledge, the above-described waste material was managed in compliance with all applicable laws, regulations, permits and licenses on the date listed above.

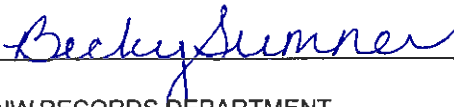

CWMNW RECORDS DEPARTMENT

Date: 11/12/13



WASTE MANAGEMENT
17629 Cedar Springs Lane
Arlington, OR 97812

PORT OF TACOMA
WAD001882984
3400 TAYLOR WAY
TACOMA WA 98421

CERTIFICATE OF DISPOSAL

Chemical Waste Management of the Northwest, Inc., ORD089452353, has received the following waste material:

GENERATOR:	PORT OF TACOMA
MANIFEST #:	011886827JJK
CWM TRACKING ID:	430437-01
PROFILE #:	OR321468
LINE ITEM:	9b.1
QUANTITY:	1 DT
RECEIVED DATE:	11/06/13
DISPOSAL PROCESS(ES):	LANDFILL
FINAL DISPOSAL LOCATION:	LANDFILL 14
DISPOSAL DATE:	11/06/13

I certify, on behalf of the above listed treatment facility, that to the best of my knowledge, the above-described waste material was managed in compliance with all applicable laws, regulations, permits and licenses on the date listed above.

Becky Sumner

CWMNW RECORDS DEPARTMENT

Date: 11/12/13



WASTE MANAGEMENT
17629 Cedar Springs Lane
Arlington, OR 97812

PORT OF TACOMA
WAD001882984
3400 TAYLOR WAY
TACOMA WA 98421

CERTIFICATE OF DISPOSAL

Chemical Waste Management of the Northwest, Inc., ORD089452353, has received the following waste material:

GENERATOR:	PORT OF TACOMA
MANIFEST #:	011886825JJK
CWM TRACKING ID:	430448-01
PROFILE #:	OR321468
LINE ITEM:	9b.1
QUANTITY:	1 DT
RECEIVED DATE:	11/07/13
DISPOSAL PROCESS(ES):	LANDFILL
FINAL DISPOSAL LOCATION:	LANDFILL 14
DISPOSAL DATE:	11/07/13

I certify, on behalf of the above listed treatment facility, that to the best of my knowledge, the above-described waste material was managed in compliance with all applicable laws, regulations, permits and licenses on the date listed above.

CWMNW RECORDS DEPARTMENT

Date: 11/12/13



WASTE MANAGEMENT
17629 Cedar Springs Lane
Arlington, OR 97812

PORT OF TACOMA
WAD001882984
3400 TAYLOR WAY
TACOMA WA 98421

CERTIFICATE OF DISPOSAL

Chemical Waste Management of the Northwest, Inc., ORD089452353, has received the following waste material:

GENERATOR:	PORT OF TACOMA
MANIFEST #:	011886818JJK
CWM TRACKING ID:	430487-01
PROFILE #:	OR321468
LINE ITEM:	9b.1
QUANTITY:	1 DT
RECEIVED DATE:	11/07/13
DISPOSAL PROCESS(ES):	LANDFILL
FINAL DISPOSAL LOCATION:	LANDFILL 14
DISPOSAL DATE:	11/07/13

I certify, on behalf of the above listed treatment facility, that to the best of my knowledge, the above-described waste material was managed in compliance with all applicable laws, regulations, permits and licenses on the date listed above.

CWMNW RECORDS DEPARTMENT

Date: 11/12/13



WASTE MANAGEMENT
17629 Cedar Springs Lane
Arlington, OR 97812

PORT OF TACOMA
WAD001882984
3400 TAYLOR WAY
TACOMA WA 98421

CERTIFICATE OF DISPOSAL

Chemical Waste Management of the Northwest, Inc., ORD089452353, has received the following waste material:

GENERATOR:	PORT OF TACOMA
MANIFEST #:	011886819JJK
CWM TRACKING ID:	430499-01
PROFILE #:	OR321468
LINE ITEM:	9b.1
QUANTITY:	1 DT
RECEIVED DATE:	11/07/13
DISPOSAL PROCESS(ES):	LANDFILL
FINAL DISPOSAL LOCATION:	LANDFILL 14
DISPOSAL DATE:	11/07/13

I certify, on behalf of the above listed treatment facility, that to the best of my knowledge, the above-described waste material was managed in compliance with all applicable laws, regulations, permits and licenses on the date listed above.

CWMNW RECORDS DEPARTMENT

Date: 11/12/13



WASTE MANAGEMENT
17629 Cedar Springs Lane
Arlington, OR 97812

PORT OF TACOMA
WAD001882984
3400 TAYLOR WAY
TACOMA WA 98421

CERTIFICATE OF DISPOSAL

Chemical Waste Management of the Northwest, Inc., ORD089452353, has received the following waste material:

GENERATOR:	PORT OF TACOMA
MANIFEST #:	011886812JJK
CWM TRACKING ID:	430500-01
PROFILE #:	OR321468
LINE ITEM:	9b.1
QUANTITY:	1 DT
RECEIVED DATE:	11/07/13
DISPOSAL PROCESS(ES):	LANDFILL
FINAL DISPOSAL LOCATION:	LANDFILL 14
DISPOSAL DATE:	11/07/13

I certify, on behalf of the above listed treatment facility, that to the best of my knowledge, the above-described waste material was managed in compliance with all applicable laws, regulations, permits and licenses on the date listed above.

Becky Sumner

CWMNW RECORDS DEPARTMENT

Date: 11/12/13



WASTE MANAGEMENT
17629 Cedar Springs Lane
Arlington, OR 97812

PORT OF TACOMA
WAD001882984
3400 TAYLOR WAY
TACOMA WA 98421

CERTIFICATE OF DISPOSAL

Chemical Waste Management of the Northwest, Inc., ORD089452353, has received the following waste material:

GENERATOR:	PORT OF TACOMA
MANIFEST #:	011886814JJK
CWM TRACKING ID:	430501-01
PROFILE #:	OR321468
LINE ITEM:	9b.1
QUANTITY:	1 DT
RECEIVED DATE:	11/07/13
DISPOSAL PROCESS(ES):	LANDFILL
FINAL DISPOSAL LOCATION:	LANDFILL 14
DISPOSAL DATE:	11/07/13

I certify, on behalf of the above listed treatment facility, that to the best of my knowledge, the above-described waste material was managed in compliance with all applicable laws, regulations, permits and licenses on the date listed above.

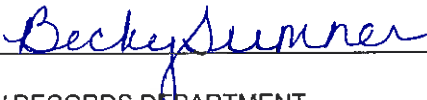

CWMNW RECORDS DEPARTMENT

Date: 11/12/13



WASTE MANAGEMENT
17629 Cedar Springs Lane
Arlington, OR 97812

PORT OF TACOMA
WAD001882984
3400 TAYLOR WAY
TACOMA WA 98421

CERTIFICATE OF DISPOSAL

Chemical Waste Management of the Northwest, Inc., ORD089452353, has received the following waste material:

GENERATOR:	PORT OF TACOMA
MANIFEST #:	011886815JJK
CWM TRACKING ID:	430502-01
PROFILE #:	OR321468
LINE ITEM:	9b.1
QUANTITY:	1 DT
RECEIVED DATE:	11/07/13
DISPOSAL PROCESS(ES):	LANDFILL
FINAL DISPOSAL LOCATION:	LANDFILL 14
DISPOSAL DATE:	11/07/13

I certify, on behalf of the above listed treatment facility, that to the best of my knowledge, the above-described waste material was managed in compliance with all applicable laws, regulations, permits and licenses on the date listed above.

CWMNW RECORDS DEPARTMENT

Date: 11/12/13



WASTE MANAGEMENT
17629 Cedar Springs Lane
Arlington, OR 97812

PORT OF TACOMA
WAD001882984
3400 TAYLOR WAY
TACOMA WA 98421

CERTIFICATE OF DISPOSAL

Chemical Waste Management of the Northwest, Inc., ORD089452353, has received the following waste material:

GENERATOR:	PORT OF TACOMA
MANIFEST #:	011886813JJK
CWM TRACKING ID:	430503-01
PROFILE #:	OR321468
LINE ITEM:	9b.1
QUANTITY:	1 DT
RECEIVED DATE:	11/07/13
DISPOSAL PROCESS(ES):	LANDFILL
FINAL DISPOSAL LOCATION:	LANDFILL 14
DISPOSAL DATE:	11/07/13

I certify, on behalf of the above listed treatment facility, that to the best of my knowledge, the above-described waste material was managed in compliance with all applicable laws, regulations, permits and licenses on the date listed above.

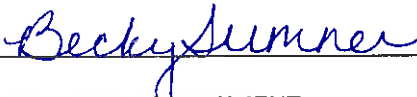

CWMNW RECORDS DEPARTMENT

Date: 11/12/13



WASTE MANAGEMENT
17629 Cedar Springs Lane
Arlington, OR 97812

PORT OF TACOMA
WAD001882984
3400 TAYLOR WAY
TACOMA WA 98421

CERTIFICATE OF DISPOSAL

Chemical Waste Management of the Northwest, Inc., ORD089452353, has received the following waste material:

GENERATOR:	PORT OF TACOMA
MANIFEST #:	011886816JJK
CWM TRACKING ID:	430504-01
PROFILE #:	OR321468
LINE ITEM:	9b.1
QUANTITY:	1 DT
RECEIVED DATE:	11/07/13
DISPOSAL PROCESS(ES):	LANDFILL
FINAL DISPOSAL LOCATION:	LANDFILL 14
DISPOSAL DATE:	11/07/13

I certify, on behalf of the above listed treatment facility, that to the best of my knowledge, the above-described waste material was managed in compliance with all applicable laws, regulations, permits and licenses on the date listed above.

Becky Sumner

CWMNW RECORDS DEPARTMENT

Date: 11/12/13



WASTE MANAGEMENT
17629 Cedar Springs Lane
Arlington, OR 97812

PORT OF TACOMA
WAD001882984
3400 TAYLOR WAY
TACOMA WA 98421

CERTIFICATE OF DISPOSAL

Chemical Waste Management of the Northwest, Inc., ORD089452353, has received the following waste material:

GENERATOR:	PORT OF TACOMA
MANIFEST #:	011886807JJK
CWM TRACKING ID:	430506-01
PROFILE #:	OR321468
LINE ITEM:	9b.1
QUANTITY:	1 DT
RECEIVED DATE:	11/07/13
DISPOSAL PROCESS(ES):	LANDFILL
FINAL DISPOSAL LOCATION:	LANDFILL 14
DISPOSAL DATE:	11/07/13

I certify, on behalf of the above listed treatment facility, that to the best of my knowledge, the above-described waste material was managed in compliance with all applicable laws, regulations, permits and licenses on the date listed above.

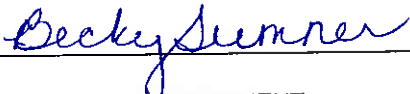

CWMNW RECORDS DEPARTMENT

Date: 11/12/13



WASTE MANAGEMENT
17629 Cedar Springs Lane
Arlington, OR 97812

PORT OF TACOMA
WAD001882984
3400 TAYLOR WAY
TACOMA WA 98421

CERTIFICATE OF DISPOSAL

Chemical Waste Management of the Northwest, Inc., ORD089452353, has received the following waste material:

GENERATOR:	PORT OF TACOMA
MANIFEST #:	011886822JJK
CWM TRACKING ID:	430509-01
PROFILE #:	OR321468
LINE ITEM:	9b.1
QUANTITY:	1 DT
RECEIVED DATE:	11/07/13
DISPOSAL PROCESS(ES):	LANDFILL
FINAL DISPOSAL LOCATION:	LANDFILL 14
DISPOSAL DATE:	11/07/13

I certify, on behalf of the above listed treatment facility, that to the best of my knowledge, the above-described waste material was managed in compliance with all applicable laws, regulations, permits and licenses on the date listed above.

Becky Sumner

CWMNW RECORDS DEPARTMENT

Date: 11/12/13



WASTE MANAGEMENT
17629 Cedar Springs Lane
Arlington, OR 97812

PORT OF TACOMA
WAD001882984
3400 TAYLOR WAY
TACOMA WA 98421

CERTIFICATE OF DISPOSAL

Chemical Waste Management of the Northwest, Inc., ORD089452353, has received the following waste material:

GENERATOR:	PORT OF TACOMA
MANIFEST #:	011886811JJK
CWM TRACKING ID:	430510-01
PROFILE #:	OR321468
LINE ITEM:	9b.1
QUANTITY:	1 DT
RECEIVED DATE:	11/07/13
DISPOSAL PROCESS(ES):	LANDFILL
FINAL DISPOSAL LOCATION:	LANDFILL 14
DISPOSAL DATE:	11/07/13

I certify, on behalf of the above listed treatment facility, that to the best of my knowledge, the above-described waste material was managed in compliance with all applicable laws, regulations, permits and licenses on the date listed above.

CWMNW RECORDS DEPARTMENT

Date: 11/12/13



WASTE MANAGEMENT
17629 Cedar Springs Lane
Arlington, OR 97812

PORT OF TACOMA
WAD001882984
3400 TAYLOR WAY
TACOMA WA 98421

CERTIFICATE OF DISPOSAL

Chemical Waste Management of the Northwest, Inc., ORD089452353, has received the following waste material:

GENERATOR:	PORT OF TACOMA
MANIFEST #:	011886817JJK
CWM TRACKING ID:	430513-01
PROFILE #:	OR321468
LINE ITEM:	9b.1
QUANTITY:	1 DT
RECEIVED DATE:	11/07/13
DISPOSAL PROCESS(ES):	LANDFILL
FINAL DISPOSAL LOCATION:	LANDFILL 14
DISPOSAL DATE:	11/07/13

I certify, on behalf of the above listed treatment facility, that to the best of my knowledge, the above-described waste material was managed in compliance with all applicable laws, regulations, permits and licenses on the date listed above.



CWMNW RECORDS DEPARTMENT

Date: 11/12/13



WASTE MANAGEMENT
17629 Cedar Springs Lane
Arlington, OR 97812

PORT OF TACOMA
WAD001882984
3400 TAYLOR WAY
TACOMA WA 98421

CERTIFICATE OF DISPOSAL

Chemical Waste Management of the Northwest, Inc., ORD089452353, has received the following waste material:

GENERATOR:	PORT OF TACOMA
MANIFEST #:	011886809JJK
CWM TRACKING ID:	430516-01
PROFILE #:	OR321468
LINE ITEM:	9b.1
QUANTITY:	1 DT
RECEIVED DATE:	11/07/13
DISPOSAL PROCESS(ES):	LANDFILL
FINAL DISPOSAL LOCATION:	LANDFILL 14
DISPOSAL DATE:	11/07/13

I certify, on behalf of the above listed treatment facility, that to the best of my knowledge, the above-described waste material was managed in compliance with all applicable laws, regulations, permits and licenses on the date listed above.

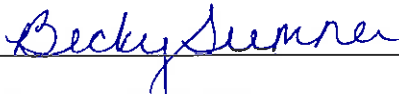

CWMNW RECORDS DEPARTMENT

Date: 11/12/13



WASTE MANAGEMENT
17629 Cedar Springs Lane
Arlington, OR 97812

PORT OF TACOMA
WAD001882984
3400 TAYLOR WAY
TACOMA WA 98421

CERTIFICATE OF DISPOSAL

Chemical Waste Management of the Northwest, Inc., ORD089452353, has received the following waste material:

GENERATOR:	PORT OF TACOMA
MANIFEST #:	011886808JJK
CWM TRACKING ID:	430517-01
PROFILE #:	OR321468
LINE ITEM:	9b.1
QUANTITY:	1 DT
RECEIVED DATE:	11/07/13
DISPOSAL PROCESS(ES):	LANDFILL
FINAL DISPOSAL LOCATION:	LANDFILL 14
DISPOSAL DATE:	11/07/13

I certify, on behalf of the above listed treatment facility, that to the best of my knowledge, the above-described waste material was managed in compliance with all applicable laws, regulations, permits and licenses on the date listed above.

CWMNW RECORDS DEPARTMENT

Date: 11/12/13



WASTE MANAGEMENT
17629 Cedar Springs Lane
Arlington, OR 97812

PORT OF TACOMA
WAD001882984
3400 TAYLOR WAY
TACOMA WA 98421

CERTIFICATE OF DISPOSAL

Chemical Waste Management of the Northwest, Inc., ORD089452353, has received the following waste material:

GENERATOR:	PORT OF TACOMA
MANIFEST #:	011886806JJK
CWM TRACKING ID:	430518-01
PROFILE #:	OR321468
LINE ITEM:	9b.1
QUANTITY:	1 DT
RECEIVED DATE:	11/07/13
DISPOSAL PROCESS(ES):	LANDFILL
FINAL DISPOSAL LOCATION:	LANDFILL 14
DISPOSAL DATE:	11/07/13

I certify, on behalf of the above listed treatment facility, that to the best of my knowledge, the above-described waste material was managed in compliance with all applicable laws, regulations, permits and licenses on the date listed above.

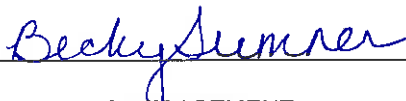

CWMNW RECORDS DEPARTMENT

Date: 11/12/13



WASTE MANAGEMENT
17629 Cedar Springs Lane
Arlington, OR 97812

PORT OF TACOMA
WAD001882984
3400 TAYLOR WAY
TACOMA WA 98421

CERTIFICATE OF DISPOSAL

Chemical Waste Management of the Northwest, Inc., ORD089452353, has received the following waste material:

GENERATOR:	PORT OF TACOMA
MANIFEST #:	011886799JJK
CWM TRACKING ID:	430520-01
PROFILE #:	OR321468
LINE ITEM:	9b.1
QUANTITY:	1 DT
RECEIVED DATE:	11/07/13
DISPOSAL PROCESS(ES):	LANDFILL
FINAL DISPOSAL LOCATION:	LANDFILL 14
DISPOSAL DATE:	11/07/13

I certify, on behalf of the above listed treatment facility, that to the best of my knowledge, the above-described waste material was managed in compliance with all applicable laws, regulations, permits and licenses on the date listed above.



CWMNW RECORDS DEPARTMENT

Date: 11/12/13



WASTE MANAGEMENT
17629 Cedar Springs Lane
Arlington, OR 97812

PORT OF TACOMA
WAD001882984
3400 TAYLOR WAY
TACOMA WA 98421

CERTIFICATE OF DISPOSAL

Chemical Waste Management of the Northwest, Inc., ORD089452353, has received the following waste material:

GENERATOR:	PORT OF TACOMA
MANIFEST #:	011886800JJK
CWM TRACKING ID:	430521-01
PROFILE #:	OR321468
LINE ITEM:	9b.1
QUANTITY:	1 DT
RECEIVED DATE:	11/07/13
DISPOSAL PROCESS(ES):	LANDFILL
FINAL DISPOSAL LOCATION:	LANDFILL 14
DISPOSAL DATE:	11/07/13

I certify, on behalf of the above listed treatment facility, that to the best of my knowledge, the above-described waste material was managed in compliance with all applicable laws, regulations, permits and licenses on the date listed above.

Becky Sumner

_____ CWMNW RECORDS DEPARTMENT

Date: 11/12/13



WASTE MANAGEMENT
17629 Cedar Springs Lane
Arlington, OR 97812

PORT OF TACOMA
WAD001882984
3400 TAYLOR WAY
TACOMA WA 98421

CERTIFICATE OF DISPOSAL

Chemical Waste Management of the Northwest, Inc., ORD089452353, has received the following waste material:

GENERATOR:	PORT OF TACOMA
MANIFEST #:	011886801JJK
CWM TRACKING ID:	430522-01
PROFILE #:	OR321468
LINE ITEM:	9b.1
QUANTITY:	1 DT
RECEIVED DATE:	11/07/13
DISPOSAL PROCESS(ES):	LANDFILL
FINAL DISPOSAL LOCATION:	LANDFILL 14
DISPOSAL DATE:	11/07/13

I certify, on behalf of the above listed treatment facility, that to the best of my knowledge, the above-described waste material was managed in compliance with all applicable laws, regulations, permits and licenses on the date listed above.

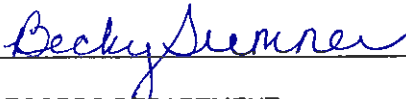

CWMNW RECORDS DEPARTMENT

Date: 11/12/13



WASTE MANAGEMENT
17629 Cedar Springs Lane
Arlington, OR 97812

PORT OF TACOMA
WAD001882984
3400 TAYLOR WAY
TACOMA WA 98421

CERTIFICATE OF DISPOSAL

Chemical Waste Management of the Northwest, Inc., ORD089452353, has received the following waste material:

GENERATOR:	PORT OF TACOMA
MANIFEST #:	011886805JJK
CWM TRACKING ID:	430524-01
PROFILE #:	OR321468
LINE ITEM:	9b.1
QUANTITY:	1 DT
RECEIVED DATE:	11/07/13
DISPOSAL PROCESS(ES):	LANDFILL
FINAL DISPOSAL LOCATION:	LANDFILL 14
DISPOSAL DATE:	11/07/13

I certify, on behalf of the above listed treatment facility, that to the best of my knowledge, the above-described waste material was managed in compliance with all applicable laws, regulations, permits and licenses on the date listed above.

CWMNW RECORDS DEPARTMENT

Date: 11/12/13



WASTE MANAGEMENT
17629 Cedar Springs Lane
Arlington, OR 97812

PORT OF TACOMA
WAD001882984
3400 TAYLOR WAY
TACOMA WA 98421

CERTIFICATE OF DISPOSAL

Chemical Waste Management of the Northwest, Inc., ORD089452353, has received the following waste material:

GENERATOR:	PORT OF TACOMA
MANIFEST #:	011886810JJK
CWM TRACKING ID:	430527-01
PROFILE #:	OR321468
LINE ITEM:	9b.1
QUANTITY:	1 DT
RECEIVED DATE:	11/07/13
DISPOSAL PROCESS(ES):	LANDFILL
FINAL DISPOSAL LOCATION:	LANDFILL 14
DISPOSAL DATE:	11/07/13

I certify, on behalf of the above listed treatment facility, that to the best of my knowledge, the above-described waste material was managed in compliance with all applicable laws, regulations, permits and licenses on the date listed above.

Becky Sumner

CWMNW RECORDS DEPARTMENT

Date: 11/12/13



WASTE MANAGEMENT
17629 Cedar Springs Lane
Arlington, OR 97812

PORT OF TACOMA
WAD001882984
3400 TAYLOR WAY
TACOMA WA 98421

CERTIFICATE OF DISPOSAL

Chemical Waste Management of the Northwest, Inc., ORD089452353, has received the following waste material:

GENERATOR:	PORT OF TACOMA
MANIFEST #:	011886803JJK
CWM TRACKING ID:	430529-01
PROFILE #:	OR321468
LINE ITEM:	9b.1
QUANTITY:	1 DT
RECEIVED DATE:	11/07/13
DISPOSAL PROCESS(ES):	LANDFILL
FINAL DISPOSAL LOCATION:	LANDFILL 14
DISPOSAL DATE:	11/07/13

I certify, on behalf of the above listed treatment facility, that to the best of my knowledge, the above-described waste material was managed in compliance with all applicable laws, regulations, permits and licenses on the date listed above.

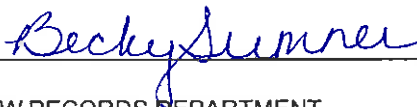

CWMNW RECORDS DEPARTMENT

Date: 11/12/13



WASTE MANAGEMENT
17629 Cedar Springs Lane
Arlington, OR 97812

PORT OF TACOMA
WAD001882984
3400 TAYLOR WAY
TACOMA WA 98421

CERTIFICATE OF DISPOSAL

Chemical Waste Management of the Northwest, Inc., ORD089452353, has received the following waste material:

GENERATOR:	PORT OF TACOMA
MANIFEST #:	011886804JJK
CWM TRACKING ID:	430530-01
PROFILE #:	OR321468
LINE ITEM:	9b.1
QUANTITY:	1 DT
RECEIVED DATE:	11/07/13
DISPOSAL PROCESS(ES):	LANDFILL
FINAL DISPOSAL LOCATION:	LANDFILL 14
DISPOSAL DATE:	11/07/13

I certify, on behalf of the above listed treatment facility, that to the best of my knowledge, the above-described waste material was managed in compliance with all applicable laws, regulations, permits and licenses on the date listed above.

CWMNW RECORDS DEPARTMENT

Date: 11/12/13



WASTE MANAGEMENT
17629 Cedar Springs Lane
Arlington, OR 97812

PORT OF TACOMA
WAD001882984
3400 TAYLOR WAY
TACOMA WA 98421

CERTIFICATE OF DISPOSAL

Chemical Waste Management of the Northwest, Inc., ORD089452353, has received the following waste material:

GENERATOR:	PORT OF TACOMA
MANIFEST #:	011871793JJK
CWM TRACKING ID:	430604-01
PROFILE #:	OR321468
LINE ITEM:	9b.1
QUANTITY:	1 DT
RECEIVED DATE:	11/11/13
DISPOSAL PROCESS(ES):	LANDFILL
FINAL DISPOSAL LOCATION:	LANDFILL 14
DISPOSAL DATE:	11/11/13

I certify, on behalf of the above listed treatment facility, that to the best of my knowledge, the above-described waste material was managed in compliance with all applicable laws, regulations, permits and licenses on the date listed above.

Becky Sumner

CWMNW RECORDS DEPARTMENT

Date: 11/18/13



WASTE MANAGEMENT
17629 Cedar Springs Lane
Arlington, OR 97812

PORT OF TACOMA
WAD001882984
3400 TAYLOR WAY
TACOMA WA 98421

CERTIFICATE OF DISPOSAL

Chemical Waste Management of the Northwest, Inc., ORD089452353, has received the following waste material:

GENERATOR:	PORT OF TACOMA
MANIFEST #:	011871794JJK
CWM TRACKING ID:	430606-01
PROFILE #:	OR321468
LINE ITEM:	9b.1
QUANTITY:	1 DT
RECEIVED DATE:	11/11/13
DISPOSAL PROCESS(ES):	LANDFILL
FINAL DISPOSAL LOCATION:	LANDFILL 14
DISPOSAL DATE:	11/11/13

I certify, on behalf of the above listed treatment facility, that to the best of my knowledge, the above-described waste material was managed in compliance with all applicable laws, regulations, permits and licenses on the date listed above.

Becky Sumner

CWMNW RECORDS DEPARTMENT

Date: 11/19/13



WASTE MANAGEMENT
17629 Cedar Springs Lane
Arlington, OR 97812

PORT OF TACOMA
WAD001882984
3400 TAYLOR WAY
TACOMA WA 98421

CERTIFICATE OF DISPOSAL

Chemical Waste Management of the Northwest, Inc., ORD089452353, has received the following waste material:

GENERATOR:	PORT OF TACOMA
MANIFEST #:	011871795JJK
CWM TRACKING ID:	430807-01
PROFILE #:	OR321468
LINE ITEM:	9b.1
QUANTITY:	1 DT
RECEIVED DATE:	11/11/13
DISPOSAL PROCESS(ES):	LANDFILL
FINAL DISPOSAL LOCATION:	LANDFILL 14
DISPOSAL DATE:	11/11/13

I certify, on behalf of the above listed treatment facility, that to the best of my knowledge, the above-described waste material was managed in compliance with all applicable laws, regulations, permits and licenses on the date listed above.

Becky Sumner

CWMNW RECORDS DEPARTMENT

Date: 11/19/13



WASTE MANAGEMENT
17629 Cedar Springs Lane
Arlington, OR 97812

PORT OF TACOMA
WAD001882984
3400 TAYLOR WAY
TACOMA WA 98421

CERTIFICATE OF DISPOSAL

Chemical Waste Management of the Northwest, Inc., ORD089452353, has received the following waste material:

GENERATOR:	PORT OF TACOMA
MANIFEST #:	011871796JJK
CWM TRACKING ID:	430608-01
PROFILE #:	OR321468
LINE ITEM:	9b.1
QUANTITY:	1 DT
RECEIVED DATE:	11/11/13
DISPOSAL PROCESS(ES):	LANDFILL
FINAL DISPOSAL LOCATION:	LANDFILL 14
DISPOSAL DATE:	11/11/13

I certify, on behalf of the above listed treatment facility, that to the best of my knowledge, the above-described waste material was managed in compliance with all applicable laws, regulations, permits and licenses on the date listed above.

Becky Sumner

CWMNW RECORDS DEPARTMENT

Date: 11/19/13



WASTE MANAGEMENT
17629 Cedar Springs Lane
Arlington, OR 97812

PORT OF TACOMA
WAD001882984
3400 TAYLOR WAY
TACOMA WA 98421

CERTIFICATE OF DISPOSAL

Chemical Waste Management of the Northwest, Inc., ORD089452353, has received the following waste material:

GENERATOR:	PORT OF TACOMA
MANIFEST #:	011871797JJK
CWM TRACKING ID:	430614-01
PROFILE #:	OR321468
LINE ITEM:	9b.1
QUANTITY:	1 DT
RECEIVED DATE:	11/11/13
DISPOSAL PROCESS(ES):	LANDFILL
FINAL DISPOSAL LOCATION:	LANDFILL 14
DISPOSAL DATE:	11/11/13

I certify, on behalf of the above listed treatment facility, that to the best of my knowledge, the above-described waste material was managed in compliance with all applicable laws, regulations, permits and licenses on the date listed above.

Becky Sumner

CWMNW RECORDS DEPARTMENT

Date: 11/19/13



WASTE MANAGEMENT
17629 Cedar Springs Lane
Arlington, OR 97812

PORT OF TACOMA
WAD001882964
3400 TAYLOR WAY
TACOMA WA 98421

CERTIFICATE OF DISPOSAL

Chemical Waste Management of the Northwest, Inc., ORD089452353, has received the following waste material:

GENERATOR:	PORT OF TACOMA
MANIFEST #:	011871799JJK
CWM TRACKING ID:	430615-01
PROFILE #:	OR321468
LINE ITEM:	9b.1
QUANTITY:	1 DT
RECEIVED DATE:	11/11/13
DISPOSAL PROCESS(ES):	LANDFILL
FINAL DISPOSAL LOCATION:	LANDFILL 14
DISPOSAL DATE:	11/11/13

I certify, on behalf of the above listed treatment facility, that to the best of my knowledge, the above-described waste material was managed in compliance with all applicable laws, regulations, permits and licenses on the date listed above.

Becky Sumner

CWMNW RECORDS DEPARTMENT

Date: 11/19/13



WASTE MANAGEMENT
17629 Cedar Springs Lane
Arlington, OR 97812

PORT OF TACOMA
WAD001882984
3400 TAYLOR WAY
TACOMA WA 98421

CERTIFICATE OF DISPOSAL

Chemical Waste Management of the Northwest, Inc., ORD089452353, has received the following waste material:

GENERATOR:	PORT OF TACOMA
MANIFEST #:	011886802JJK
CWM TRACKING ID:	430616-01
PROFILE #:	OR321468
LINE ITEM:	9b.1
QUANTITY:	1 DT
RECEIVED DATE:	11/11/13
DISPOSAL PROCESS(ES):	LANDFILL
FINAL DISPOSAL LOCATION:	LANDFILL 14
DISPOSAL DATE:	11/11/13

I certify, on behalf of the above listed treatment facility, that to the best of my knowledge, the above-described waste material was managed in compliance with all applicable laws, regulations, permits and licenses on the date listed above.

Becky Sumner

CWMNW RECORDS DEPARTMENT

Date: 11/19/13



WASTE MANAGEMENT
17629 Cedar Springs Lane
Arlington, OR 97812

PORT OF TACOMA
WAD001882984
3400 TAYLOR WAY
TACOMA WA 98421

CERTIFICATE OF DISPOSAL

Chemical Waste Management of the Northwest, Inc., ORD080452353, has received the following waste material:

GENERATOR:	PORT OF TACOMA
MANIFEST #:	011871798JJK
CWM TRACKING ID:	430617-01
PROFILE #:	OR321488
LINE ITEM:	9b.1
QUANTITY:	1 DT
RECEIVED DATE:	11/11/13
DISPOSAL PROCESS(ES):	LANDFILL
FINAL DISPOSAL LOCATION:	LANDFILL 14
DISPOSAL DATE:	11/11/13

I certify, on behalf of the above listed treatment facility, that to the best of my knowledge, the above-described waste material was managed in compliance with all applicable laws, regulations, permits and licenses on the date listed above.

Becky Sumner

CWMNW RECORDS DEPARTMENT

Date: 11/19/13



WASTE MANAGEMENT
17629 Cedar Springs Lane
Arlington, OR 97812

PORT OF TACOMA
WAD001882984
3400 TAYLOR WAY
TACOMA WA 98421

CERTIFICATE OF DISPOSAL

Chemical Waste Management of the Northwest, Inc., ORD089452353, has received the following waste material:

GENERATOR:	PORT OF TACOMA
MANIFEST #:	011871800JJK
CWM TRACKING ID:	430820-01
PROFILE #:	OR321468
LINE ITEM:	9b.1
QUANTITY:	1 DT
RECEIVED DATE:	11/11/13
DISPOSAL PROCESS(ES):	LANDFILL
FINAL DISPOSAL LOCATION:	LANDFILL 14
DISPOSAL DATE:	11/11/13

I certify, on behalf of the above listed treatment facility, that to the best of my knowledge, the above-described waste material was managed in compliance with all applicable laws, regulations, permits and licenses on the date listed above.

Becky Sumner

CWMNW RECORDS DEPARTMENT

Date: 11/19/13



WASTE MANAGEMENT
17629 Cedar Springs Lane
Arlington, OR 97812

PORT OF TACOMA
WAD001882984
3400 TAYLOR WAY
TACOMA WA 98421

CERTIFICATE OF DISPOSAL

Chemical Waste Management of the Northwest, Inc., ORD089452353, has received the following waste material:

GENERATOR:	PORT OF TACOMA
MANIFEST #:	011871806JJK
CWM TRACKING ID:	430621-01
PROFILE #:	OR321468
LINE ITEM:	9b.1
QUANTITY:	1 DT
RECEIVED DATE:	11/11/13
DISPOSAL PROCESS(ES):	LANDFILL
FINAL DISPOSAL LOCATION:	LANDFILL 14
DISPOSAL DATE:	11/11/13

I certify, on behalf of the above listed treatment facility, that to the best of my knowledge, the above-described waste material was managed in compliance with all applicable laws, regulations, permits and licenses on the date listed above.

Becky Sumner

CWMNW RECORDS DEPARTMENT

Date: 11/19/13



WASTE MANAGEMENT
17629 Cedar Springs Lane
Arlington, OR 97812

PORT OF TACOMA
WAD001882984
3400 TAYLOR WAY
TACOMA WA 98421

CERTIFICATE OF DISPOSAL

Chemical Waste Management of the Northwest, Inc., ORD089452353, has received the following waste material:

GENERATOR:	PORT OF TACOMA
MANIFEST #:	011871807JJK
CWM TRACKING ID:	430622-01
PROFILE #:	OR321468
LINE ITEM:	9b.1
QUANTITY:	1 DT
RECEIVED DATE:	11/11/13
DISPOSAL PROCESS(ES):	LANDFILL
FINAL DISPOSAL LOCATION:	LANDFILL 14
DISPOSAL DATE:	11/11/13

I certify, on behalf of the above listed treatment facility, that to the best of my knowledge, the above-described waste material was managed in compliance with all applicable laws, regulations, permits and licenses on the date listed above.

Becky Sumner

CWMNW RECORDS DEPARTMENT

Date: 11/19/13



WASTE MANAGEMENT
17629 Cedar Springs Lane
Arlington, OR 97812

PORT OF TACOMA
WAD001882984
3400 TAYLOR WAY
TACOMA WA 98421

CERTIFICATE OF DISPOSAL

Chemical Waste Management of the Northwest, Inc., ORD089452353, has received the following waste material:

GENERATOR:	PORT OF TACOMA
MANIFEST #:	011871805JJK
CWM TRACKING ID:	430623-01
PROFILE #:	OR321468
LINE ITEM:	9b.1
QUANTITY:	1 DT
RECEIVED DATE:	11/11/13
DISPOSAL PROCESS(ES):	LANDFILL
FINAL DISPOSAL LOCATION:	LANDFILL 14
DISPOSAL DATE:	11/11/13

I certify, on behalf of the above listed treatment facility, that to the best of my knowledge, the above-described waste material was managed in compliance with all applicable laws, regulations, permits and licenses on the date listed above.

Becky Sumner

CWMNW RECORDS DEPARTMENT

Date: 11/19/13



WASTE MANAGEMENT
17629 Cedar Springs Lane
Arlington, OR 97812

PORT OF TACOMA
WAD001882984
3400 TAYLOR WAY
TACOMA WA 98421

CERTIFICATE OF DISPOSAL

Chemical Waste Management of the Northwest, Inc., ORD089452353, has received the following waste material:

GENERATOR:	PORT OF TACOMA
MANIFEST #:	011871802JJK
CWM TRACKING ID:	430824-01
PROFILE #:	OR321468
LINE ITEM:	9b.1
QUANTITY:	1 DT
RECEIVED DATE:	11/11/13
DISPOSAL PROCESS(ES):	LANDFILL
FINAL DISPOSAL LOCATION:	LANDFILL 14
DISPOSAL DATE:	11/11/13

I certify, on behalf of the above listed treatment facility, that to the best of my knowledge, the above-described waste material was managed in compliance with all applicable laws, regulations, permits and licenses on the date listed above.

Becky Sumner

CWMNW RECORDS DEPARTMENT

Date: 11/19/13



WASTE MANAGEMENT
17629 Cedar Springs Lane
Arlington, OR 97812

PORT OF TACOMA
WAD001882984
3400 TAYLOR WAY
TACOMA WA 98421

CERTIFICATE OF DISPOSAL

Chemical Waste Management of the Northwest, Inc., ORD089452353, has received the following waste material:

GENERATOR:	PORT OF TACOMA
MANIFEST #:	011871804JJK
CWM TRACKING ID:	430825-01
PROFILE #:	OR321468
LINE ITEM:	9b.1
QUANTITY:	1 DT
RECEIVED DATE:	11/11/13
DISPOSAL PROCESS(ES):	LANDFILL
FINAL DISPOSAL LOCATION:	LANDFILL 14
DISPOSAL DATE:	11/11/13

I certify, on behalf of the above listed treatment facility, that to the best of my knowledge, the above-described waste material was managed in compliance with all applicable laws, regulations, permits and licenses on the date listed above.

Becky Sumner

CWMNW RECORDS DEPARTMENT

Date: 11/19/13



WASTE MANAGEMENT
17629 Cedar Springs Lane
Arlington, OR 97812

PORT OF TACOMA
WAD001882984
3400 TAYLOR WAY
TACOMA WA 98421

CERTIFICATE OF DISPOSAL

Chemical Waste Management of the Northwest, Inc., ORD089452353, has received the following waste material:

GENERATOR:	PORT OF TACOMA
MANIFEST #:	011871801JJK
CWM TRACKING ID:	430826-01
PROFILE #:	OR321468
LINE ITEM:	9b.1
QUANTITY:	1 DT
RECEIVED DATE:	11/11/13
DISPOSAL PROCESS(ES):	LANDFILL
FINAL DISPOSAL LOCATION:	LANDFILL 14
DISPOSAL DATE:	11/11/13

I certify, on behalf of the above listed treatment facility, that to the best of my knowledge, the above-described waste material was managed in compliance with all applicable laws, regulations, permits and licenses on the date listed above.

Becky Sumner

CWMNW RECORDS DEPARTMENT

Date: 11/19/13



WASTE MANAGEMENT
17629 Cedar Springs Lane
Arlington, OR 97812

PORT OF TACOMA
WAD001882984
3400 TAYLOR WAY
TACOMA WA 98421

CERTIFICATE OF DISPOSAL

Chemical Waste Management of the Northwest, Inc., ORD089452353, has received the following waste material:

GENERATOR:	PORT OF TACOMA
MANIFEST #:	011871792JJK
CWM TRACKING ID:	430627-01
PROFILE #:	OR321468
LINE ITEM:	9b.1
QUANTITY:	1 DT
RECEIVED DATE:	11/11/13
DISPOSAL PROCESS(ES):	LANDFILL
FINAL DISPOSAL LOCATION:	LANDFILL 14
DISPOSAL DATE:	11/11/13

I certify, on behalf of the above listed treatment facility, that to the best of my knowledge, the above-described waste material was managed in compliance with all applicable laws, regulations, permits and licenses on the date listed above.

Becky Sumner

CWMNW RECORDS DEPARTMENT

Date: 11/19/13



WASTE MANAGEMENT
17629 Cedar Springs Lane
Arlington, OR 97812

PORT OF TACOMA
WAD001882984
3400 TAYLOR WAY
TACOMA WA 98421

CERTIFICATE OF DISPOSAL

Chemical Waste Management of the Northwest, Inc., ORD089452353, has received the following waste material:

GENERATOR:	PORT OF TACOMA
MANIFEST #:	011871808JJK
CWM TRACKING ID:	430630-01
PROFILE #:	OR321468
LINE ITEM:	9b.1
QUANTITY:	1 DT
RECEIVED DATE:	11/11/13
DISPOSAL PROCESS(ES):	LANDFILL
FINAL DISPOSAL LOCATION:	LANDFILL 14
DISPOSAL DATE:	11/11/13

I certify, on behalf of the above listed treatment facility, that to the best of my knowledge, the above-described waste material was managed in compliance with all applicable laws, regulations, permits and licenses on the date listed above.

Becky Sumner

CWMNW RECORDS DEPARTMENT

Date: 11/19/13



WASTE MANAGEMENT
17629 Cedar Springs Lane
Arlington, OR 97812

PORT OF TACOMA
WAD001882984
3400 TAYLOR WAY
TACOMA WA 98421

CERTIFICATE OF DISPOSAL

Chemical Waste Management of the Northwest, Inc., ORD089452353, has received the following waste material:

GENERATOR:	PORT OF TACOMA
MANIFEST #:	011871803JJK
CWM TRACKING ID:	430831-01
PROFILE #:	OR321468
LINE ITEM:	9b.1
QUANTITY:	1 DT
RECEIVED DATE:	11/11/13
DISPOSAL PROCESS(ES):	LANDFILL
FINAL DISPOSAL LOCATION:	LANDFILL 14
DISPOSAL DATE:	11/11/13

I certify, on behalf of the above listed treatment facility, that to the best of my knowledge, the above-described waste material was managed in compliance with all applicable laws, regulations, permits and licenses on the date listed above.

Becky Sumner

CWMNW RECORDS DEPARTMENT

Date: 11/19/13



WASTE MANAGEMENT
17629 Cedar Springs Lane
Arlington, OR 97812

PORT OF TACOMA
WAD001882984
3400 TAYLOR WAY
TACOMA WA 98421

CERTIFICATE OF DISPOSAL

Chemical Waste Management of the Northwest, Inc., ORD089452353, has received the following waste material:

GENERATOR:	PORT OF TACOMA
MANIFEST #:	011871811JJK
CWM TRACKING ID:	430717-01
PROFILE #:	OR321488
LINE ITEM:	9b.1
QUANTITY:	1 DT
RECEIVED DATE:	11/13/13
DISPOSAL PROCESS(ES):	LANDFILL
FINAL DISPOSAL LOCATION:	LANDFILL 14
DISPOSAL DATE:	11/13/13

I certify, on behalf of the above listed treatment facility, that to the best of my knowledge, the above-described waste material was managed in compliance with all applicable laws, regulations, permits and licenses on the date listed above.

Becky Sumner

CWMNW RECORDS DEPARTMENT

Date: 11/20/13



WASTE MANAGEMENT
17629 Cedar Springs Lane
Arlington, OR 97812

PORT OF TACOMA
WAD001882984
3400 TAYLOR WAY
TACOMA WA 98421

CERTIFICATE OF DISPOSAL

Chemical Waste Management of the Northwest, Inc., ORD089452353, has received the following waste material:

GENERATOR:	PORT OF TACOMA
MANIFEST #:	011871809JJK
CWM TRACKING ID:	430722-01
PROFILE #:	OR321488
LINE ITEM:	9b.1
QUANTITY:	1 DT
RECEIVED DATE:	11/13/13
DISPOSAL PROCESS(ES):	LANDFILL
FINAL DISPOSAL LOCATION:	LANDFILL 14
DISPOSAL DATE:	11/13/13

I certify, on behalf of the above listed treatment facility, that to the best of my knowledge, the above-described waste material was managed in compliance with all applicable laws, regulations, permits and licenses on the date listed above.

Becky Sumner

CWMNW RECORDS DEPARTMENT

Date: 11/20/13



WASTE MANAGEMENT
17629 Cedar Springs Lane
Arlington, OR 97812

PORT OF TACOMA
WAD001882984
3400 TAYLOR WAY
TACOMA WA 98421

CERTIFICATE OF DISPOSAL

Chemical Waste Management of the Northwest, Inc., ORD089452353, has received the following waste material:

GENERATOR:	PORT OF TACOMA
MANIFEST #:	011871810JJK
CWM TRACKING ID:	430724-01
PROFILE #:	OR321468
LINE ITEM:	9b.1
QUANTITY:	1 DT
RECEIVED DATE:	11/13/13
DISPOSAL PROCESS(ES):	LANDFILL
FINAL DISPOSAL LOCATION:	LANDFILL 14
DISPOSAL DATE:	11/13/13

I certify, on behalf of the above listed treatment facility, that to the best of my knowledge, the above-described waste material was managed in compliance with all applicable laws, regulations, permits and licenses on the date listed above.

A handwritten signature in cursive script that reads "Becky Sumner".

CWMNW RECORDS DEPARTMENT

Date: 11/20/13



WASTE MANAGEMENT
17629 Cedar Springs Lane
Arlington, OR 97812

PORT OF TACOMA
WAD001882984
3400 TAYLOR WAY
TACOMA WA 98421

CERTIFICATE OF DISPOSAL

Chemical Waste Management of the Northwest, Inc., ORD089452353, has received the following waste material:

GENERATOR:	PORT OF TACOMA
MANIFEST #:	011871814JJK
CWM TRACKING ID:	430762-01
PROFILE #:	OR321468
LINE ITEM:	9b.1
QUANTITY:	1 DT
RECEIVED DATE:	11/14/13
DISPOSAL PROCESS(ES):	LANDFILL
FINAL DISPOSAL LOCATION:	LANDFILL 14
DISPOSAL DATE:	11/14/13

I certify, on behalf of the above listed treatment facility, that to the best of my knowledge, the above-described waste material was managed in compliance with all applicable laws, regulations, permits and licenses on the date listed above.

Becky Sumner

CWMNW RECORDS DEPARTMENT

Date: 11/20/13



WASTE MANAGEMENT
17629 Cedar Springs Lane
Arlington, OR 97812

PORT OF TACOMA
WAD001882984
3400 TAYLOR WAY
TACOMA WA 98421

CERTIFICATE OF DISPOSAL

Chemical Waste Management of the Northwest, Inc., ORD089452353, has received the following waste material:

GENERATOR:	PORT OF TACOMA	
MANIFEST #:	011871815JJK	
CWM TRACKING ID:	430765-01	
PROFILE #:	OR321468	
LINE ITEM:	9b.1	
QUANTITY:	1 DT	
RECEIVED DATE:	11/14/13	
DISPOSAL PROCESS(ES):	LANDFILL	
FINAL DISPOSAL LOCATION:	LANDFILL	14
DISPOSAL DATE:	11/14/13	

I certify, on behalf of the above listed treatment facility, that to the best of my knowledge, the above-described waste material was managed in compliance with all applicable laws, regulations, permits and licenses on the date listed above.

Becky Sumner

CWMNW RECORDS DEPARTMENT

Date: 11/20/13



WASTE MANAGEMENT
17629 Cedar Springs Lane
Arlington, OR 97812

PORT OF TACOMA
WAD001882984
3400 TAYLOR WAY
TACOMA WA 98421

CERTIFICATE OF DISPOSAL

Chemical Waste Management of the Northwest, Inc., ORD089452353, has received the following waste material:

GENERATOR:	PORT OF TACOMA	
MANIFEST #:	011871813JJK	
CWM TRACKING ID:	430768-01	
PROFILE #:	OR321468	
LINE ITEM:	9b.1	
QUANTITY:	1 DT	
RECEIVED DATE:	11/14/13	
DISPOSAL PROCESS(ES):	LANDFILL	
FINAL DISPOSAL LOCATION:	LANDFILL	14
DISPOSAL DATE:	11/14/13	

I certify, on behalf of the above listed treatment facility, that to the best of my knowledge, the above-described waste material was managed in compliance with all applicable laws, regulations, permits and licenses on the date listed above.

Becky Sumner

CWMNW RECORDS DEPARTMENT

Date: 11/20/13



WASTE MANAGEMENT
17629 Cedar Springs Lane
Arlington, OR 97812

PORT OF TACOMA
WAD001882984
3400 TAYLOR WAY
TACOMA WA 98421

CERTIFICATE OF DISPOSAL

Chemical Waste Management of the Northwest, Inc., ORD089452353, has received the following waste material:

GENERATOR:	PORT OF TACOMA	
MANIFEST #:	011871816JJK	
CWM TRACKING ID:	430770-01	
PROFILE #:	OR321468	
LINE ITEM:	9b.1	
QUANTITY:	1 DT	
RECEIVED DATE:	11/14/13	
DISPOSAL PROCESS(ES):	LANDFILL	
FINAL DISPOSAL LOCATION:	LANDFILL	14
DISPOSAL DATE:	11/14/13	

I certify, on behalf of the above listed treatment facility, that to the best of my knowledge, the above-described waste material was managed in compliance with all applicable laws, regulations, permits and licenses on the date listed above.

Becky Sumner

CWMNW RECORDS DEPARTMENT

Date: 11/20/13



WASTE MANAGEMENT
17629 Cedar Springs Lane
Arlington, OR 97812

PORT OF TACOMA
WAD001882984
3400 TAYLOR WAY
TACOMA WA 98421

CERTIFICATE OF DISPOSAL

Chemical Waste Management of the Northwest, Inc., ORD089452353, has received the following waste material:

GENERATOR:	PORT OF TACOMA
MANIFEST #:	011871817JJK
CWM TRACKING ID:	430771-01
PROFILE #:	OR321468
LINE ITEM:	9b.1
QUANTITY:	1 DT
RECEIVED DATE:	11/14/13
DISPOSAL PROCESS(ES):	LANDFILL
FINAL DISPOSAL LOCATION:	LANDFILL 14
DISPOSAL DATE:	11/14/13

I certify, on behalf of the above listed treatment facility, that to the best of my knowledge, the above-described waste material was managed in compliance with all applicable laws, regulations, permits and licenses on the date listed above.

Becky Sumner

CWMNW RECORDS DEPARTMENT

Date: 11/20/13



WASTE MANAGEMENT
17629 Cedar Springs Lane
Arlington, OR 97812

PORT OF TACOMA
WAD001882984
3400 TAYLOR WAY
TACOMA WA 98421

CERTIFICATE OF DISPOSAL

Chemical Waste Management of the Northwest, Inc., ORD089452353, has received the following waste material:

GENERATOR:	PORT OF TACOMA
MANIFEST #:	011871819JJK
CWM TRACKING ID:	430777-01
PROFILE #:	OR321468
LINE ITEM:	9b.1
QUANTITY:	1 DT
RECEIVED DATE:	11/14/13
DISPOSAL PROCESS(ES):	LANDFILL
FINAL DISPOSAL LOCATION:	LANDFILL 14
DISPOSAL DATE:	11/14/13

I certify, on behalf of the above listed treatment facility, that to the best of my knowledge, the above-described waste material was managed in compliance with all applicable laws, regulations, permits and licenses on the date listed above.

A handwritten signature in cursive script that reads 'Becky Sumner'. The signature is written over a solid horizontal line.

CWMNW RECORDS DEPARTMENT

Date: 11/20/13



WASTE MANAGEMENT
17629 Cedar Springs Lane
Arlington, OR 97812

PORT OF TACOMA
WAD001882984
3400 TAYLOR WAY
TACOMA WA 98421

CERTIFICATE OF DISPOSAL

Chemical Waste Management of the Northwest, Inc., ORD089452353, has received the following waste material:

GENERATOR:	PORT OF TACOMA
MANIFEST #:	011871820JJK
CWM TRACKING ID:	430778-01
PROFILE #:	OR321468
LINE ITEM:	9b.1
QUANTITY:	1 DT
RECEIVED DATE:	11/14/13
DISPOSAL PROCESS(ES):	LANDFILL
FINAL DISPOSAL LOCATION:	LANDFILL 14
DISPOSAL DATE:	11/14/13

I certify, on behalf of the above listed treatment facility, that to the best of my knowledge, the above-described waste material was managed in compliance with all applicable laws, regulations, permits and licenses on the date listed above.

Becky Sumner

CWMNW RECORDS DEPARTMENT

Date: 11/20/13



WASTE MANAGEMENT
17629 Cedar Springs Lane
Arlington, OR 97812

PORT OF TACOMA
WAD001882984
3400 TAYLOR WAY
TACOMA WA 98421

CERTIFICATE OF DISPOSAL

Chemical Waste Management of the Northwest, Inc., ORD089452353, has received the following waste material:

GENERATOR:	PORT OF TACOMA
MANIFEST #:	011871812JJK
CWM TRACKING ID:	430779-01
PROFILE #:	OR321468
LINE ITEM:	9b.1
QUANTITY:	1 DT
RECEIVED DATE:	11/14/13
DISPOSAL PROCESS(ES):	LANDFILL
FINAL DISPOSAL LOCATION:	LANDFILL 14
DISPOSAL DATE:	11/14/13

I certify, on behalf of the above listed treatment facility, that to the best of my knowledge, the above-described waste material was managed in compliance with all applicable laws, regulations, permits and licenses on the date listed above.

Becky Sumner

CWMNW RECORDS DEPARTMENT

Date: 11/20/13

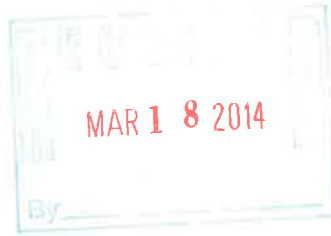

WASTE MANAGEMENT
 17629 Cedar Springs Lane
 Arlington, OR 97812

PORT OF TACOMA
 WAD001882984
 3400 TAYLOR WAY
 TACOMA WA 98421

CERTIFICATE OF DISPOSAL

Chemical Waste Management of the Northwest, Inc., ORD089452353, has received the following waste material:

GENERATOR:	PORT OF TACOMA
MANIFEST #:	OR323591-01
CWM TRACKING ID:	432966-01
PROFILE #:	OR323591
LINE ITEM:	9.1
QUANTITY:	2 DM
RECEIVED DATE:	01/22/14
DISPOSAL PROCESS(ES):	SOLIDIFICATION FOLLOWED BY LANDFILL
FINAL DISPOSAL LOCATION:	LANDFILL 14
DISPOSAL DATE:	01/30/14

I certify, on behalf of the above listed treatment facility, that to the best of my knowledge, the above-described waste material was managed in compliance with all applicable laws, regulations, permits and licenses on the date listed above.

Becky Sumner

 CWMNW RECORDS DEPARTMENT
 Date: 03/06/14