

**Chevron Environmental Management
Company**

**2010 Summary Report and Risk
Evaluation**

Former Unocal Seattle Marketing Terminal
3001 Elliott Avenue
Seattle, Washington

February 1, 2011

ARCADIS



Andrew W. Ohrt
Project Engineer



Rebecca K. Andresen, L.G.
Technical Expert

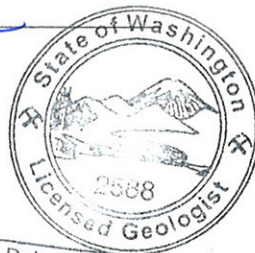

Rebecca K. Andresen

**2010 Summary Report
and Risk Evaluation**

Former Unocal Seattle
Marketing Terminal
3001 Elliott Avenue
Seattle, Washington

Prepared for:
Chevron Environmental
Management Company

Prepared by:
ARCADIS U.S., Inc.
2300 Eastlake Avenue East
Suite 200
Seattle
Washington 98102
Tel 206.325.5254
Fax 206.325.8218

Our Ref.:
B0045363

Date:
February 1, 2011

This document is intended only for the use of the individual or entity for which it was prepared and may contain information that is privileged, confidential and exempt from disclosure under applicable law. Any dissemination, distribution or copying of this document is strictly prohibited.

Acronyms and Abbreviations	vi
Executive Summary	ES-1
1. Introduction	1
2. Site Background	2
2.1 Constituents of Concern	2
2.2 Elliott Avenue Area	3
2.3 Offsite Area	5
2.4 Geology and Hydrology	7
2.4.1 Elliott Avenue Area Geology	7
2.4.2 Offsite Area Geology	8
2.4.3 Groundwater Flow Direction and Gradient	8
2.4.4 Tidal Effects on Groundwater	9
2.5 Historical LNAPL Characterization	9
2.6 Second Semiannual Groundwater Monitoring Results	10
3. Subsurface Microbiological Characterization	11
4. Natural Attenuation Monitoring	13
4.1 Results	14
4.1.1 Elliott Avenue Area	14
4.1.2 Offsite Area	15
4.2 Capacity for Intrinsic Biodegradation of Petroleum Hydrocarbons	18
5. Piezometer Installation	20
5.1 Offsite Area Piezometer Installation	20
5.2 Elliott Avenue Piezometer Installation	21
5.3 Piezometer Installation Analytical Results	22
5.3.1 Offsite Area	22
5.3.2 Elliott Avenue Area	23

6. Well Development	24
6.1 New Piezometer Development	24
6.2 Existing Monitoring Well Redevelopment	25
7. Surfactant-Enhanced LNAPL Recovery Pilot Testing	26
7.1 Injection Methods	26
7.2 Injection Monitoring	26
7.3 Surfactant Extraction	28
7.4 Surfactant Monitoring Results	29
7.5 Surfactant-Enhanced LNAPL Recovery Pilot Test Conclusions	30
8. Hydraulic Conductivity Testing	31
8.1 Oil-Water Separator Maintenance	31
8.2 Pumping Tests	31
8.2.1 Step Drawdown Testing Field Methods and Results	31
8.2.2 Constant Rate Pumping Tests	35
8.3 Constant Rate Pumping Test Data Analysis	36
8.4 Constant Rate Pumping Test Results	37
8.5 MW-205 LNAPL Observation	40
9. Dissolved-Phase COC Fate and Transport Evaluation	41
9.1 Groundwater Velocity	41
9.2 COC Velocity in Groundwater	42
9.3 First-Order COC Biodegradation Rate Constants and Half-Lives in Groundwater	43
9.3.1 BTEX First-Order Rate Constants and Half-Lives	43
9.3.2 TPH First-Order Rate Constant and Half-Life	44
9.3.3 cPAH First-Order Rate Constants and Half-Lives	44
9.4 COC Concentration at the Sea Wall	45
9.5 COC Discharge to Elliott Bay	45
9.6 Dissolved-Phase COC Fate and Transport Conclusions	47

10. LNAPL Mobility Assessment	49
11. Human Health and Ecological Risk Evaluation – Elliott Ave and Offsite Area	50
11.1 Exposure Assessment	50
11.2 Conceptual Site Model	50
11.2.1 Potential Constituent Sources	50
11.2.2 Potential Transport Pathways and Receptors – Human Health	51
11.2.3 Potential Transport Pathways and Receptors – Ecological	54
11.2.4 Comparison of Offsite Area Groundwater COC Concentrations with Site RALs	54
11.2.5 Comparison of Soil Concentration Data with Soil Screening Criteria	57
11.3 Exposure Pathways Summary	58
12. Summary and Conclusions	59
13. Recommendations	61
14. References	62

Tables

Table 1	Summary of Groundwater Analytical Data – Total Petroleum Hydrocarbons
Table 2	Summary of Groundwater Analytical Data – Polynuclear Aromatic Hydrocarbons
Table 3	Monitoring Well History
Table 4	Summary of Groundwater Elevation Data
Table 5	Summary of Groundwater Compliance as of Second Semiannual 2010
Table 6	Summary of Geochemical Parameter Field Data
Table 7	Summary of Geochemical Parameter Analytical Data
Table 8	Summary of Piezometer Installation Soil Analytical Data
Table 9	Summary of Piezometer and Monitoring Well Development and Redevelopment Activities

Table 10 Summary of Surfactant Monitoring Data

Table 11 Summary of Hydraulic Conductivity Testing Activities

Table 12 Summary of Hydraulic Conductivity Testing Results

Table 13 Summary of Hydraulic Conductivity, Average Linear Groundwater Velocity and Travel Time

Table 14 Summary of COC Chemical Properties

Table 15 Estimated Groundwater and COC Discharge to Puget Sound

Table 16 Summary of Current Groundwater Concentrations, RALs and Maximum Predicted Groundwater COC Concentrations at the Sea Wall

Figures

Figure 1 Site Location Map

Figure 2 Site Map

Figure 3 Offsite Area Historical Well Locations and 2005 Excavation

Figure 4 Groundwater Elevations – September 21, 2010

Figure 5 Groundwater TPH Analytical Summary Map – Second Semi-Annual 2010

Figure 6 Groundwater cPAH Data –Second Semi-Annual 2010

Figure 7 Geochemical Parameter Summary Map – April 2010

Figure 8 Sulfate and COC Concentrations Along Transect

Figure 9 Methane, Carbon Dioxide and COC Concentrations Along Transect

Figure 10 Dissolved Iron, Dissolved Manganese and COC Concentrations Along Transect

Figure 11 New Piezometer Locations

Figure 12 Mounding in Well MW-61A-R During Surfactant Injection Operations

Figure 13 Surfactant Injection Monitoring in Well MW-30

Figure 14 Surfactant Injection Monitoring in Piezometer PZ-61A-R

Figure 15 Average Hydraulic Gradient Condition

Figure 16 Conceptual Site Model – Elliott Avenue and Offsite Areas

Appendices

- A Historical Boring Logs
- B Microbial Insights Laboratory Report
- C Groundwater Monitoring Field Sheets
- D Geochemical Parameter Laboratory Analytical Report
- E Biodegradation Capacity Sample Calculation
- F New Boring Logs
- G Soil Laboratory Analytical Report
- H Well Development Field Sheets
- I Step Drawdown Testing Results
- J Constant Rate Pumping Test Results
- K First-Order Rate Constant Graphs
- L LNAPL Mobility and Migration Assessment
- M Soil Core Photographs
- N Soil Core Laboratory Analytical Reports
- O LNAPL Mobility Input Parameters and Results

addendum	Addendum to the Revised Work Plan for LNAPL Mobility Assessment, Natural Attenuation Monitoring and Surfactant Application Pilot Testing
API	American Petroleum Institute
ARCADIS	ARCADIS U.S., Inc.
ASTM	ASTM International
AWCD	Air-Water Capillary Pressure Drainage
BaP	benzo(a)pyrene
bgs	below ground surface
BNSF	Burlington Northern-Santa Fe
BTEX	benzene, toluene, ethylbenzene and total xylenes
CDF	controlled density fill
cm	centimeter(s)
cm/sec	centimeter(s) per second
COC	constituent of concern
cPAH	carcinogenic polyaromatic hydrocarbon
CSM	conceptual site model
d ⁻¹	per day
DO	dissolved oxygen
dyne/cm	dyne/centimeter
Ecology	Washington State Department of Ecology

Fe(II)	ferrous iron
Fe(III)	ferric iron
FPM	free product mobility
ft/ft	foot per foot
g/cm ³	grams per cubic centimeter
gpm	gallons per minute
ITRC	Interstate Technology & Regulatory Council
K-values	hydraulic conductivity values
kg/L	kilograms per liter
lb/year	pound per year
LNAPL	light nonaqueous-phase liquid
mg/kg	milligram(s) per kilogram
mg/L	milligram(s) per liter
mL/year	milliliters per year
MI	Microbial Insights
Mn(II)	manganous (dissolved) manganese
Mn(IV)	manganic manganese
MTCA	Model Toxics Control Act
mV	millivolt(s)
NTU	nephelometric turbidity unit

NWTPH-Dx	Northwest Total Petroleum Hydrocarbon method for semivolatile petroleum products
NWTPH-Gx	Northwest Total Petroleum Hydrocarbon method for volatile petroleum products
Order	Order on Consent DE 88-N223
ORP	oxidation-reduction potential
OSP	Olympic Sculpture Park
partitioning coefficient	compound-specific soil organic carbon-water partitioning coefficient
PFS	Pore Fluid Saturation
PID	photo ionization detector
PLFA	phospholipid fatty acid
PVC	polyvinyl chloride
RAL	remedial action level
RETC	Retention Curve Program for Unsaturated Soils
ROW	right-of-way
RSWD	residual saturation by water drive
SAM	Seattle Art Museum
site	Former Unocal Seattle Marketing Terminal, located at 3001 Elliott Avenue in Seattle, Washington
SRB	sulfate-reducing bacteria
summary report	2010 Summary Report and Risk Evaluation

SVE	soil vapor extraction
TPH	total petroleum hydrocarbon
TPH-D	total petroleum hydrocarbons as diesel
TPH-G	total petroleum hydrocarbons as gasoline
TPH-O	total petroleum hydrocarbons as oil
USCS	United Soil Classification System
USEPA	United States Environmental Protection Agency
UV	ultraviolet
vG-B	van Genuchten-Burdine
vG-M	van Genuchten-Mualem
VOC	volatile organic compound
work plan	Revised Work Plan for LNAPL Mobility Assessment, Natural Attenuation Monitoring and Surfactant Application Pilot Testing
µg-HC/L	microgram(s) of hydrocarbon per liter
µg/L	micrograms per liter
µS/cm	microSiemens per centimeter

On behalf of Chevron Environmental Management Company, ARCADIS U.S., Inc. (ARCADIS) prepared this 2010 Summary Report and Risk Evaluation (summary report) to document field activities completed at the Former Unocal Seattle Marketing Terminal, located at 3001 Elliott Avenue in Seattle, Washington (site). The field activities were conducted to characterize subsurface conditions and characterize the human health and ecological risk from remaining petroleum hydrocarbon impacts at the site. ARCADIS performed the field activities in accordance with the Revised Work Plan for LNAPL Mobility Assessment, Natural Attenuation Monitoring and Surfactant Application Pilot Testing dated January 19, 2010 (ARCADIS 2010a) and amended in the Addendum to the Revised Work Plan for LNAPL Mobility Assessment, Natural Attenuation Monitoring and Surfactant Application Pilot Testing dated May 3, 2010 (ARCADIS 2010b).

The site was a bulk fuel distribution facility from 1912 to approximately 1975. Leaded and unleaded gasoline, diesel, lube oil, motor oils and petroleum-based solvents (nonchlorinated) were stored at the site. In the 1980s, facility-related site structures were demolished with the exception of a brick building located at the south end of the Lower Yard. The site is defined in Order on Consent DE 88-N223 and is divided into four contiguous areas (Upper Yard, Elliott Avenue Area, Lower Yard and the Offsite Area). The Upper Yard and Lower Yard of the site were sold by Unocal to the Trust for Public Land for the Seattle Art Museum (SAM) in 1999. In 2004, the SAM began construction for redevelopment of the site (including the Offsite Area, which is now owned by the City of Seattle Parks and Recreation Department) as the Olympic Sculpture Park, which was completed in early 2007.

Significant historical assessment and remedial activities have been completed at the site and minor/isolated residual impacts to soil and groundwater remain at the site. Between April and September 2010, ARCADIS completed characterization activities to assess fate and transport of constituents of concern in groundwater in the Elliott Avenue and Offsite Areas at the site. These characterization activities included microbiological sampling, monitored natural attenuation parameter sampling, hydraulic conductivity testing and a light nonaqueous-phase liquid (LNAPL) mobility assessment. In addition, a surfactant-enhanced LNAPL pilot test was completed to remediate LNAPL in well MW-61A-R.

Although there are a few isolated areas of remaining impacts to soil and groundwater in the Offsite Area and beneath Elliott Avenue, the data collected do not suggest the need for additional remedial measures. Remaining soil impacts do not present a risk to human health and the environment due to the absence of a complete or significant

exposure pathway. Microbiological and geochemical parameter monitoring for the remaining dissolved-phase impacts in groundwater indicate that natural attenuation processes are occurring and that groundwater at the site likely has excess capacity for further attenuation of petroleum hydrocarbons. Aquifer testing data and conservative modeling indicate that the remaining dissolved-phase concentrations in groundwater will not reach Elliott Bay. Where LNAPL is present, dissolved-phase concentrations do not exceed remedial action levels and petrophysical data indicate that the LNAPL at the site is largely immobile. It is further recommended that the Trench D recovery system wells be properly decommissioned.

1. Introduction

On behalf of Chevron Environmental Management Company, ARCADIS U.S., Inc. (ARCADIS) has prepared this 2010 Summary Report and Risk Evaluation (summary report) for the Former Unocal Seattle Marketing Terminal, located at 3001 Elliott Avenue in Seattle, Washington (the site). The site and surrounding area are shown on Figure 1.

This summary report summarizes the results of the field work proposed in the Revised Work Plan for LNAPL Mobility Assessment, Natural Attenuation Monitoring and Surfactant Application Pilot Testing (work plan) dated January 19, 2010 and amended in the Addendum to the Revised Work Plan for LNAPL Mobility Assessment, Natural Attenuation Monitoring and Surfactant Application Pilot Testing (addendum) dated May 3, 2010 (ARCADIS 2010a and 2010b). The work plan (ARCADIS 2010a) was prepared in response to a request from the Washington State Department of Ecology (Ecology) in a letter dated June 8, 2009. This summary report also presents a risk evaluation for the Elliott Avenue Area and Offsite Area including a reassessment of carcinogenic polycyclic aromatic hydrocarbons (cPAHs) at the site and a summary of proposed future activities at the site.

2. Site Background

The site was a bulk fuel distribution facility from 1912 to approximately 1975. Leaded and unleaded gasoline, diesel, lube oil, motor oils and petroleum-based solvents (nonchlorinated) were stored at the site. In the 1980s, facility-related site structures were demolished with the exception of a brick building at the south end of the Lower Yard.

The site is defined in Order on Consent DE 88-N223 (Order) and is divided into four contiguous areas (Upper Yard, Elliott Avenue Area, Lower Yard and the Offsite Area), as shown on Figure 2. The Upper Yard and Lower Yard of the site were sold by Unocal to the Trust for Public Land for the Seattle Art Museum (SAM) in 1999. In 2004, the SAM began construction for redevelopment of the site (including the Offsite Area, which is now owned by the City of Seattle Parks and Recreation Department) as the Olympic Sculpture Park (OSP), which was completed in early 2007.

Monitoring of site monitoring wells has been conducted since 1989. The current monitoring well network is shown on Figure 2. The Upper Yard and Lower Yard are in compliance with conditions of the Order and remedial and monitoring operations have been discontinued. Well MW-61A-R is a replacement for well MW-61A, which was originally an Upper Yard monitoring well. However, MW-61A-R is located in the Elliott Avenue right-of-way (ROW) and is currently considered an Elliott Avenue Area monitoring well. With the exception of three monitoring wells (MW-201, MW-202 and MW-204) in the Offsite Area, dissolved-phase concentrations exceeding the remedial action levels (RALs) are no longer present at the site.

2.1 Constituents of Concern

The current constituents of concern (COCs) at the site as identified in Amendment 4 of the Order are:

- TPH-G
- total petroleum hydrocarbons as diesel (TPH-D)
- total petroleum hydrocarbons as oil (TPH-O)
- benzene, toluene, ethylbenzene and total xylenes (BTEX)

- cPAHs (benzo(a)anthracene, benzo(a)pyrene [BaP], benzo(b)fluoranthene, benzo(k)fluoranthene, chrysene, dibenzo(a,h)anthracene and indeno(1,2,3-cd)pyrene)
- dissolved lead

RALs for the site (as presented in Tables 1 and 2) were established in 1988 in the Order and amended in Amendment No. 4 (Ecology 1995). A groundwater RAL for no visible sheen, as evaluated by field measurements, is also included for each of the site areas. The current RALs predate the current Model Toxics Control Act (MTCA). Based on calculations accepted under current MTCA guidance, cPAH concentrations have remained below MTCA criteria since 2003 (ARCADIS 2010a).

2.2 Elliott Avenue Area

The portion of the former Unocal Seattle Marketing Terminal known as the Elliott Avenue Area is currently occupied by the Elliott Avenue ROW and is bordered on the east and west by the OSP. A pedestrian overpass across Elliott Avenue connects the two parts of the OSP and is shown on Figure 2.

Prior to development of the site as a bulk facility, the shoreline of Elliott Bay was approximately where Elliott Avenue is located now, indicating that areas westward are man-made areas of substantial fill. Elliott Avenue is a city-owned public ROW and has been used for automobile and foot traffic since before the construction of the Unocal terminal in 1912.

A remediation system was installed in 1989 on both sides of Elliott Avenue. The system was composed of both soil vapor extraction (SVE) and pump and treat groundwater components. The system was designed to pump treated and amended groundwater for reinjection to facilitate bioremediation. The pump and treat portion of the system operated until May 1991 and recovered approximately 4,900,000 gallons of water. The system did not recover measureable LNAPL (GeoEngineers 1996a). During remedial operations in the Upper Yard in 1997, Unocal removed approximately 57,000 tons of petroleum-impacted soil (GeoEngineers 1997c). However, approximately 110 cubic yards of soil were left in place due to its depth (16 to 26 feet below ground surface [bgs]) along the northwest boundary with Elliott Avenue (HartCrowser 1999). The impacted soil is near the location of well MW-61A-R, which extends to 31 feet bgs.

The Remedy Selection Report for Elliott Avenue (GeoEngineers 1996b) selected hand bailing of free product from monitoring wells as the appropriate remedial solution for this section of the site. This decision was based on the difficulties of operating around extensive surface and subsurface utilities and infrastructure. In addition, the report addresses the volume and mobility of LNAPL remaining in the subsurface. Based on site assessment work to identify the extent of the LNAPL and laboratory testing to calculate viscosity, GeoEngineers estimated approximately 626 years for LNAPL to migrate from the area of MW-30 to the western edge of the Lower Yard (approximately 144 feet). Subsequent remedial efforts to remove LNAPL between 1997 and 1999 in this area using oil sorbent material or hand bailing achieved only 1 liter of LNAPL removal from wells MW-30 and MW-59 (HartCrowser 1999).

The LNAPL characteristics observed in well MW-30 and recorded by ARCADIS field staff since 2007 qualitatively support the initial GeoEngineers mobility estimate. The only measurable thickness (0.02 foot) of LNAPL observed in MW-30 since 2002 was on May 12, 2009. The LNAPL is very viscous and has limited to no recoverability based on field observations. Physical tests could not be performed due to the lack of recoverability.

In addition, in February 1997, five hand auger borings were advanced in the northwest corner of the Upper Yard approximately 90 feet north of MW-61A-R to evaluate the potential for impacted soil in the area. Soil samples were collected to a depth of 8 feet bgs and TPH-D (10.6 milligrams per kilogram [mg/kg]) and TPH-O (62.7 mg/kg) were the only COCs detected. Concentrations were below the total petroleum hydrocarbon (TPH) soil cleanup level of 200 mg/kg. Soil samples were not collected deeper than 8 feet bgs due to auger refusal.

In summary, an estimated 110 cubic feet of petroleum-impacted soil was left in place beneath the Upper Yard along the northwest boundary of Elliott Avenue during Upper Yard excavation due to depth limitations and the presence of a shoring wall that was used during the 1997 Upper Yard excavation activities (GeoEngineers 1997c). The soil is reportedly located between 16 and 26 feet bgs; lateral extent was not established. Based on current depths to groundwater from well MW-61A-R, it is likely that the impacted soil is below the top of the groundwater. It is likely that the LNAPL impact in the Elliott Avenue Area is due to mass remaining in the soil left in place and is inaccessible due to subsurface and above ground infrastructure in the area (e.g. utilities and pedestrian overcrossing). The Elliott Avenue monitoring well history is summarized in Table 3. Based on historic data, the LNAPL appears to be isolated and unrecoverable.

2.3 Offsite Area

The Offsite Area was historically the location of tidal lowlands, a wood-planked timber trestle roadway and a wharf for a local asphalt company that was present on the northern portion of the former Upper Yard (prior to use by Unocal). This area was filled in between approximately 1905 and the 1930s. Fill materials included materials from various regrading projects in Seattle (including asphalt and building materials as well as sawmill debris), wood and other materials included as a means of landfill. The former wooden-pile-supported roadway today remains in place below-grade. During the filling operations, a series of sea walls were constructed prior to construction of the final and current concrete sea wall in the 1930s (GeoEngineers 1996b).

Until the late 1960s, Alaskan Way continued along the railroad ROW (through what is now the Offsite Area) and was used for street traffic and parking. Beginning in 1969, Alaskan Way was turned into a parking lot and was no longer used for through traffic. In 1982, a Seattle Metro trolley barn and spur tracks to the barn were constructed (GeoEngineers 1996b).

Petroleum piping associated with former terminal operations extended from the Lower Yard, beneath the railroad ROW and across the Offsite Area to the location of the former Unocal pier (Figure 2). This included more than 20 three- to eight-inch-diameter pipes. The below-grade piping was abandoned in place in 1988 at the same time as remedial operations began at the site (GeoEngineers 1996b). Some of the piping was incorporated as conduit containing remediation piping for the current Offsite Area remediation system (GeoEngineers 1997b).

In 1989, an offsite remediation system was installed and began operation on either side of the railroad ROW. This offsite remediation system was designed similar to the system on Elliott Avenue, to extract water from Trench D (west side of the railroad tracks), treat extracted groundwater by amending with oxygen and nutrients, and reinject into Trench C (east side of the railroad tracks). An SVE component of the system operated from 1989 through 1995, at which time it was turned off due to low recovery of volatiles. Although Trench D was initially designed as a trench, it was ultimately constructed as 15 individual extraction wells, each designed to have a dedicated pump (Carlisle, pers. comm. 2010). Ten additional extraction wells outside of Trench D were installed on both sides of the Burlington Northern-Santa Fe (BNSF) railroad tracks (GeoEngineers 1997b). Nutrient amendment of the extracted groundwater was suspended in 1995 because it was deemed to be no longer effective. In 1996, reinfiltration into Trench C was suspended and a permit was obtained to

discharge to the local sanitary sewer. Extracted groundwater was treated through an oil-water separator and aeration prior to discharge (GeoEngineers 1997b).

The offsite remediation system continued to operate until December 2006, when the underground piping connecting the extraction wells to the system equipment was severely damaged during construction of the OSP. The offsite remediation system has remained deactivated temporarily, with approval from Ecology on an interim basis to better understand groundwater quality conditions. From 1989 to November 2006, approximately 29,244,966 gallons of water and 4,809 gallons of LNAPL were recovered and treated by the groundwater extraction system. No LNAPL was subsequently recovered by the system from the fourth quarter 2004 until December 2006 when the system became inoperable (GeoEngineers 2006b).

With approval from Ecology, Unocal conducted soil remedial excavation between July and October 2005 to remove a previously identified "hot spot" of impacted soil in the Offsite Area. In preparation for the excavation, an approximately 200-foot-long shoring wall was installed on the edge of the railroad ROW as shown on Figures 2 and 3. The shoring wall was installed to approximately 25 feet bgs and was constructed of steel piles and wooden lagging boards with controlled density fill to stabilize loose soil. Upon completion of the excavation, the top 4 feet of the piles and boards were removed and the rest was left in place (GeoEngineers 2006a). The remaining portion of the shoring wall extends below the top of the water table and may affect groundwater flow and the nature of tidal influence in the localized subsurface. The shoring wall likely affects groundwater flow and tidal exchange in the area and may inhibit COC transport via groundwater flow.

The 2005 excavation work was originally intended to extend to the Elliott Bay sea wall. However, when the sea wall was exposed during the excavation, it was apparent that significant deterioration had occurred, and removal of overburden behind the wall may have risked collapse of the sea wall. Therefore, controlled density fill (CDF) was placed upland of the sea wall to minimize vibrations during excavation activities; soil beneath the CDF at approximately 14 feet bgs was assumed to be impacted by petroleum constituents (GeoEngineers 2006a). Monitoring well MW-202 was installed in or immediately adjacent to this soil to monitor for potential desorption of petroleum hydrocarbons into the groundwater.

A 65-foot-long section of the Unocal pipe corridor was also removed during the 2005 excavation activities. This section of the corridor had previously been abandoned in place. The pipe corridor included 25 former product pipes. A section of the pipe

corridor adjacent to a temporary shoring wall west of the railroad tracks was left in place because it could not be removed without potentially compromising the structural integrity of the sea wall. Following soil removal, the excavation was backfilled and the surface was restored with asphalt pavement. As part of the excavation activities, wells MW-8, MW-10, MW-20, MW-25, MW-26, MW-52, MW-67, MW-70, MW-71, MW-76, DW-1, DW-2, DW-7, DW-8, DW-9 and DW-10 were decommissioned. Approximately 4,435 tons of petroleum-impacted soils were removed during the 2005 remedial excavation activities. Approximately 5,620 tons of clean overburden materials were reused onsite as backfill (GeoEngineers 2006a). Because LNAPL periodically accumulated on standing water in the open excavation, 59,450 gallons of "LNAPL/oily water" were collected from the open excavation and transported offsite for disposal.

In March 2007, the Order was amended (Ecology 2007a). Included in this amendment was a provision for replacing and monitoring offsite wells that were abandoned during construction of the park (replacement monitoring wells MW-200 through MW-207). Amendment No. 5 also corrected a conflict with the current state laws under the MTCA (Ecology 2007a). Amendment No. 5 eliminated the provision for allowing exceedances in any of the wells and all compliance wells must meet the RALs to achieve compliance (Ecology 2007a). As of the second half of 2010, the only Offsite Area exceedances of site RALs are the concentration of TPH-G in well MW-204, the benzo(a)anthracene concentration in well MW-202 and the chrysene concentrations in wells MW-201 and MW-202. The Offsite Area monitoring well history is summarized in Table 3.

2.4 Geology and Hydrology

2.4.1 Elliott Avenue Area Geology

Historical assessments at the site have shown that the soil beneath Elliott Avenue has approximately 20 feet of fill material overlying glacial till, outwash deposits and beach deposits. The fill material consists of interbedded zones of sand and silty sand with gravel and sandy silt, with fill debris including brick, wood (treated and untreated), decayed wood, ash and cinders in some areas. The glacial till typically comprises dense gray silty sand with gravel and cobbles (GeoEngineers 1997a). The boring logs from MW-30 and MW-61A-R show primarily sand in the borings, with some silt and gravel present. Available historical boring logs are presented in Appendix A.

An exploration soil boring was advanced on the north side of Bay Street near the location of former well MW-74. The top 20 feet of the boring reportedly contained fill material with gravel, sand, silt, wood and creosote and petroleum impacts. Descriptions

of the creosote and petroleum reportedly encountered were not recorded (GeoEngineers 1997a).

2.4.2 Offsite Area Geology

More recent geological borings (MW-200 through MW-207, and MW-27R) were advanced in October 2006. The geology from 0 to approximately 13 feet bgs was characterized as generally sandy with some silt and gravel. While wood debris was noted in each boring at various depths, wood planking observed in intervals of varying thicknesses was reported during drilling of borings MW-200, MW-201, MW-202, MW-206, MW-207 and MW-27R. The wood planking was first observed at 11 feet bgs and was observed at 18 feet bgs at its deepest. During advancement of the wells, the following observations of wood planking were recorded:

- MW-200 – “Wood Planking, Strong Odor” from approximately 13 to 16 feet bgs
- MW-201 – “Wood Planking, Black Staining, Strong Hydrocarbon Odor” from approximately 13 to 15 feet bgs
- MW-202 – “Wood Planking, Odor” from approximately 13 to 15 feet bgs
- MW-206 – “Wood Planking Debris” and “Wood Planking” at a lower interval from approximately 15.5 to 19.5 feet bgs
- MW-207 – “Wood Planking” from approximately 10.5 to 12.5 feet bgs
- MW-27R – “Wood Planking, Strong Odor” from approximately 14.5 to 18 feet bgs

These observations of wood planking are likely related to the old railroad trestle that ran across the tidal flats, the relieving platform, or a historical sea wall used to expand the shoreline. Comparatively, the 2005 “hot spot” excavation was advanced to a depth of approximately 14 to 16 feet bgs. Below the wood planking, the soils are generally coarse sand with trace silt and gravels. Available historical boring logs are presented in Appendix A.

2.4.3 Groundwater Flow Direction and Gradient

Groundwater is generally found from 10 to 14 feet bgs along Elliott Avenue and 8 to 24 feet bgs in the Offsite Area. The general flow direction across the site is west toward Puget Sound; however, groundwater elevations in wells in the Offsite Area exhibit tidal influence. Historically, groundwater elevation measurements have been taken during varying tidal conditions. During the second semiannual 2010 groundwater monitoring event, groundwater elevations appear to reflect the overall groundwater gradient toward Puget Sound. Groundwater elevations along the railroad tracks appear to

become lower near the north end of the line of extraction wells known as Trench D; groundwater elevations in the wells nearest Puget Sound have the lowest elevation, reflecting low-low tidal conditions in Puget Sound. Upgradient of the railroad tracks, the inferred groundwater gradient generally ranges from approximately 0.007 to 0.03 foot per foot (ft/ft). West of the railroad tracks in the Offsite Area, the groundwater gradient appears to be in flux with the tidal conditions. While the gradient below the area east of the railroad tracks stays relatively consistent, groundwater elevations and gradient in the Offsite Area are directly related to tidal conditions. Historical groundwater elevation measurements are summarized in Table 4 and groundwater elevations measured during the second semiannual groundwater monitoring event are shown on Figure 4.

2.4.4 Tidal Effects on Groundwater

Continuous monitoring of groundwater elevations and conductivity to evaluate the effects of the tidal cycle on groundwater at the site was conducted in wells MW-201, MW-202, MW-203, MW-205, MW-206, MW-207 and RW-3 in the Offsite Area during August and September 2009. The results of this study were presented in the Tidal Study Summary Report (ARCADIS 2010c). The results from the study show surface water from Puget Sound directly influencing groundwater elevation in each of the wells monitored and salinity concentrations in wells MW-201, MW-202, MW-203, MW-206 and MW-207 indicative of some exchange with surface water. The amplitude of these effects varied among the wells tested, with the general trend showing a lower magnitude of effect the further the well is from Puget Sound. Effects were observed in each of the wells included in the study. Well RW-3, which is approximately 100 feet from Elliott Bay, had an average salinity of 0.43 practical salinity units (PSU) while the average salinity measured in Elliott Bay was 29.45. Salinity concentrations in each of the other wells between RW-3 and Elliott Bay ranged from 0.29 PSU in well MW-205 to 22.6 PSU in well MW-206 (ARCADIS 2010c).

2.5 Historical LNAPL Characterization

LNAPL samples have been collected from each of the wells with lingering LNAPL or sheen (RW-3, RW-21, MW-30 and MW-61A-R). Samples from wells RW-3 and RW-21 were submitted to Zymax of Escondido, California in April 2009. Both samples were characterized as primarily highly degraded California Crude Oil; the LNAPL in RW-21 has undergone a higher degree of degradation than RW-3 (ARCADIS 2010a).

LNAPL samples from MW-30 and MW-61A-R were submitted for laboratory characterization in June 2009. The LNAPL sample collected from MW-30 was also

characterized as highly degraded California crude oil. The sample from MW-61A-R was characterized as a highly degraded mid-distillate (likely No. 2 fuel oil or No. 2 diesel fuel), with trace amounts of heavy hydrocarbons (ARCADIS 2010a).

2.6 Second Semiannual Groundwater Monitoring Results

Ten monitoring wells (MW-200 through MW-207, MW-30 and MW-61A-R) were gauged and sampled quarterly and beginning in 2010 have been gauged and sampled semiannually. Analytical results indicate that as of the second half of 2010, the only Offsite Area exceedances of site RALs are the concentration of TPH-G in the sample collected from well MW-204, the benzo(a)anthracene concentration in the sample collected from well MW-202 and the chrysene concentrations in the samples collected from wells MW-201 and MW-202 (ARCADIS 2010d).

As of the second semiannual 2010 event, four monitoring wells (MW-202, MW-203, MW-206 and MW-207) have been below site RALs for at least 12 consecutive sampling events. Monitoring wells MW-200, MW-201 and MW-205 have been in compliance with the BTEX, TPH-G, TPH-D and TPH-O RALs established for the site for at least eight consecutive sampling events. However, sheen was observed once on the groundwater in these wells during field activities outside of standard groundwater monitoring operations between July and September 2010. Analytical results are summarized in Tables 1 and 2. Groundwater compliance as of the second semiannual 2010 event is summarized in Table 5 and shown on Figures 5 and 6.

3. Subsurface Microbiological Characterization

To assess the microbiological characteristics of the subsurface in the Offsite Area, ARCADIS installed Bio-Trap™ samplers in monitoring wells MW-200, MW-202, MW-204 and MW-207 from April 16 to June 16, 2010. Bio-Trap samplers are passive sampling tools that collect site-specific microbes through time to better characterize biodegradation potential.

The pre-sterilized Bio-Trap samplers were provided by Microbial Insights (MI) laboratories of Rockford, Tennessee, and were submitted back to MI after the deployment period for analysis of phospholipid fatty acids (PLFAs). PLFAs are components of intact cell walls, and different microbes generate different PLFAs at different times in their metabolic cycles. Because PLFAs break down rapidly upon cell death and the Bio-Trap samplers are sterilized prior to deployment, detection of PLFAs in Bio-Trap samplers indicates that new, site-specific microorganisms colonized the Bio-Trap samplers during the period of deployment. Furthermore, concentrations of PLFAs can indicate the quantity of viable biomass, community structure and the metabolic status of naturally occurring groundwater microorganisms present at the time of sampling, and can be used to evaluate biodegradation potential for COCs.

The MI laboratory report is provided as Appendix B and results are summarized below:

- *Biomass.* Biomass concentrations in groundwater at the site varied between approximately 3×10^5 and 9×10^5 cells per Bio-Trap bead (beads are the growth medium contained within the Bio-Traps). This is considered to be a relatively moderate amount of biomass and indicates that sufficient biomass was present in site groundwater to support in-situ bioremediation of organic COCs. Furthermore, the relatively narrow range of biomass measured in site groundwater (biomass may vary over five or more orders of magnitude) suggests that in-situ biomass was evenly distributed throughout the monitored area of the site. It must be remembered that the amount of biomass measured by the Bio-Traps may be biased low because the Bio-Traps were deployed in open water columns and were not in direct contact with site soils, which tend to support a greater quantity of biomass.
- *Community Structure.* PLFAs can be used to evaluate the structure and diversity of microbial communities because different microbes generate different PLFAs. The data show that diverse communities of microorganisms were detected in the Bio-Trap samplers at the end of the deployment period, which indicates that a healthy

and diverse population of microorganisms is present in the subsurface at the site. Approximately 61 to 76 percent of the biomass detected in the Bio-Trap samplers was found to consist of proteobacteria, which include many hydrocarbon-degrading microorganisms. Additionally, both anaerobic metal-reducing microorganisms (e.g., iron and manganese reducers) and sulfate-reducing bacteria (SRB; e.g., actinomycetes) were also detected in the Bio-Trap samplers. Both of these groups of microorganisms are associated with impacted environments and indicate that the appropriate types of microorganisms are present in the subsurface at the site to support in-situ biodegradation of organic COCs. Other types of microorganisms detected in the Bio-Trap samplers include eukaryotes and normal saturated microorganisms.

- *Metabolic Status.* PLFAs can be used to evaluate the metabolic status of microorganisms because they can adapt their cell membranes by changing the PLFA mixture when changes occur in the environment and during growth phases. For example, microorganisms can adapt to the presence of toxic conditions by making their cell membranes less permeable, which results in a predictable shift in the PLFA mixture. The data show that the microorganisms present in the Bio-Traps at the time of sampling were not significantly decreasing the permeability of their cell membranes, and that the microorganisms were not experiencing a phase of slowed growth. Rather, it can be interpreted that the microorganisms had adapted to the presence of petroleum hydrocarbons (the environment was not toxic to the microorganisms). It can also be interpreted that the microorganisms were in a relatively rapid phase of growth.

The PLFA data indicate that groundwater at the site contains a moderate amount of microbial biomass that is composed of a diverse population of microorganisms capable of biodegrading COCs in-situ, and the microbial communities were in a relatively healthy state at the time of sampling.

4. Natural Attenuation Monitoring

In April 2010, ARCADIS collected groundwater field data and samples to evaluate the current biogeochemistry and potential effectiveness of natural attenuation at the site. Groundwater samples were collected from the eight Offsite Area monitoring wells (MW-200 through MW-207) and MW-30 in conjunction with the first semiannual groundwater monitoring event. The samples were collected using low-flow sampling techniques and field parameters (pH, conductivity, temperature, dissolved oxygen [DO], turbidity and oxidation-reduction potential [ORP]) were measured using a flow-through cell and Trol® 9000 multiparameter meter. Ferrous iron (Fe[II]) and nitrate were also measured in the field using a Hach colorimetric field kit. Groundwater samples were submitted to TestAmerica of Tacoma, Washington, for the following geochemical analyses:

- total alkalinity by United States Environmental Protection Agency (USEPA) Method 310.1
- sulfate by USEPA Method 300.0
- sulfide by USEPA Method 376.1
- nitrate as nitrogen by USEPA Method 300.0 and Hach colorimetric field kit
- ammonia by USEPA Method 350.3
- total manganese by USEPA Method 6020
- dissolved manganese by USEPA Method 6020 (field filtered)
- total iron by USEPA Method 6020
- dissolved iron by field filtration and USEPA Method 6020
- total organic carbon by USEPA Method 9060 modified
- methane by Method RSK 175
- carbon dioxide by USEPA Method GC/FID-TCD

The geochemical parameter monitoring data were collected to evaluate the capacity of site soil and groundwater to support intrinsic biodegradation of COCs. The distribution of electron acceptors (DO, nitrate, manganic manganese [Mn(IV)], ferric iron (Fe[III]), sulfate and carbon dioxide) and their byproducts (carbon dioxide, manganous [dissolved] manganese [Mn(II)], Fe[II], sulfide and methane) with respect to the extent of detected benzene and TPH-G concentrations can indicate the presence and type of microbial activity within the plume. Carbon dioxide is both a metabolic byproduct of aerobic degradation and an alternate electron acceptor in methanogenesis. Analysis of the distribution of geochemical parameter concentrations with respect to COC concentrations was completed according to the recommended Tier II analysis in the Standard Guide for Remediation of Ground Water by Natural Attenuation at Petroleum

Release Sites (ASTM International [ASTM] 2004). A Tier II analysis includes collection of groundwater samples for electron acceptors and biodegradation byproducts and comparing the distribution of those concentrations and parameters to site COCs. Due to the limited COC concentrations and general lack of historical concentrations in the Offsite Area, a Tier I analysis involving assessment of historical concentration trends in individual wells was not completed.

4.1 Results

Groundwater temperatures measured in conjunction with the geochemical parameter monitoring event ranged from 12.75 to 15.28 degrees Celsius and pH ranged from 6.86 to 7.35. Both of these ranges are consistent with historical measurements and are amenable to COC biodegradation processes. The range of temperatures measured during this event was lower than temperatures measured in late summer and fall, reflecting the seasonal temperature variations of groundwater at the site.

DO concentrations measured across the site were less than 1 milligram per liter (mg/L) and are indicative of a generally anaerobic environment regardless of the presence of dissolved-phase COC concentrations. ORP measurements ranged from -218 to -54 millivolts (mV), also reflecting the lack of DO and general anaerobic state of subsurface conditions. Nitrate was not detected in any of the groundwater samples collected at the site. Ethane and ethene were not detected at the site. Ammonia, a byproduct of denitrification, was detected in each groundwater sample with the exception of MW-207, but at concentrations less than 4 mg/L. This likely indicates a general lack of nitrate in the subsurface at the site. Total organic carbon, which is supportive of methanogenic processes, was detected in each sample with the highest concentration of 6.1 mg/L detected in well MW-204. Geochemical groundwater analytical results are summarized in Table 6 and shown on Figure 7. The groundwater sampling field sheets are included in Appendix C and a laboratory analytical report is included in Appendix D.

4.1.1 Elliott Avenue Area

Metabolic byproducts detected in groundwater sampled at the Elliott Avenue Area include carbon dioxide, dissolved manganese, dissolved iron, sulfide and methane, which were detected in the groundwater sample collected at monitoring well MW-30. This information indicates that reduction of metals (iron and manganese), sulfate and carbon dioxide (i.e., methanogenesis) was occurring in-situ in groundwater due to biodegradation of site COCs. This conclusion is consistent with the presence of metals-reducing bacteria and SRB in the Bio-Trap samplers.

Mn(IV) and Mn(II) concentrations were approximately equal, indicating that nearly all of the manganese present in the groundwater sample was dissolved. A similar relationship was observed for concentrations of Fe(III) and Fe(II), respectively. These results indicate that reduced metal species predominate in groundwater in this area and support the conclusion that COCs near MW-30 are being biodegraded in-situ via naturally occurring anaerobic processes.

4.1.2 Offsite Area

DO concentrations were below 1 mg/L for each of the wells sampled in the Offsite Area, except monitoring well MW-207. In addition, ORP measurements in the Offsite Area were less than 0 mV (i.e., negative), which is consistent with a lack of DO in groundwater in this area. Electrical conductivity measurements were consistent with previous measurements collected during the 2009 tidal study and indicate that saltwater intrusion from Puget Sound continues to infiltrate and mix with relatively salt-free groundwater at the site due to daily tidal pumping associated with the nearly 14-foot tidal range measured in Puget Sound. The highest turbidity measurement of 940 nephelometric turbidity units (NTUs) was observed at monitoring well MW-204. Measurements in the remaining wells were below 50 NTUs.

A transect of wells was chosen to facilitate interpretation of geochemical parameters in the Offsite Area, with well locations extending from northernmost monitoring well MW-200 to southernmost monitoring well MW-205 (Figure 7). Wells MW-202, MW-206 and MW-207 were not included in the transect due to their proximity to Puget Sound and the influence of saltwater intrusion on geochemical parameter interpretation. For example, saltwater intrusion causes elevated sulfate concentrations in these groundwater monitoring wells, which varied between approximately 930 and 1,800 mg/L during the 2009 tidal study, thereby complicating interpretations of sulfate concentrations via the background-comparison approach.

Key geochemical indicator trends along the transect are illustrated on Figures 7, 8, 9 and 10. As shown, sulfate concentrations relative to benzene and TPH-G concentrations along the transect indicate the influence of saltwater intrusion at monitoring well MW-203, which is consistent with the results of the 2009 tidal study. This is indicated by the elevated sulfate concentration and specific conductivity measured in the well. Sulfate is an ionic constituent of seawater and contributes to specific conductivity. Also, the highest COC concentrations at monitoring well MW-204, and recent intermittent observations of sheens on groundwater at monitoring wells MW-200 and MW-201, correspond with sulfate concentrations nearly two orders of

magnitude lower than the sulfate concentration measured at monitoring well MW-203. These lower sulfate concentrations indicate that sulfate is being consumed in-situ by SRB during biodegradation of COCs. This conclusion is supported by elevated sulfide concentrations (a metabolic byproduct of sulfate reduction) that were detected in the groundwater samples collected at monitoring wells MW-202 and MW-206 and in the duplicate groundwater sample collected at monitoring well MW-204. The highest sulfide concentration was detected in a duplicate sample collected at monitoring well MW-204 at a concentration of 4.1 mg/L.

Carbon dioxide and methane concentrations relative to benzene and TPH-G concentrations along the transect are shown on Figure 9. As shown, both methane and carbon dioxide have inverse trends when compared to sulfate, which is consistent because sulfate is an electron acceptor and methane and carbon dioxide are biodegradation byproducts. The highest concentrations of methane were detected in groundwater sampled at monitoring wells MW-201 and MW-204. Carbon dioxide concentrations showed a similar trend. These results indicate that methanogenesis was occurring in groundwater at the site to some extent, and that in-situ biodegradation of site COCs was occurring through a variety of metabolic processes.

Total and dissolved metals concentrations (iron and manganese) in groundwater sampled in the Offsite Area were approximately equal, indicating that reduced metal species predominate in groundwater in this area and support the conclusion that COCs are being biodegraded in groundwater in the Offsite Area in-situ via naturally occurring anaerobic processes. Concentration trends for Fe(II) and Mn(II) are shown on Figure 10. As shown, concentrations remained relatively low with the exception of those detected in well MW-204. This is also consistent with the highest TPH-G and benzene concentrations detected in the Offsite Area, further indicating that in-situ biodegradation processes were occurring in groundwater in this area.

Bicarbonate is a product of most anaerobic biological reactions mediated by electron acceptors and a component of alkalinity in groundwater. Thus, alkalinity can be an indicator of biodegradation of petroleum hydrocarbons and was measured in each of the wells in the Offsite Area. Concentrations were detected, but did not contain a clear trend. The highest concentrations were detected in groundwater sampled at monitoring wells MW-200 and MW-201, consistent with carbon dioxide concentrations. Concentrations of alkalinity and carbon dioxide were correlated, which indicates that geochemical data are of good quality.

The geochemical parameter data also show that groundwater is largely forced to flow around the “hot spot” excavation shoring wall to maintain the general trend of groundwater flow toward Puget Sound. This is indicated by the distribution of electron acceptors and metabolic byproducts in Offsite Area monitoring wells. Geochemical parameter concentrations detected in monitoring wells MW-200 and MW-201 to the north of the shoring wall and MW-204 and MW-205 to the south of the shoring wall contain different distributions of geochemical parameter concentrations compared to well MW-203, which is located approximately in the middle of the shoring wall. Both sets of wells at either end of the wall contain geochemical parameter concentrations that are strong indicators of biodegradation of COCs at the site, including low sulfate concentrations and high concentrations of carbon dioxide and methane. Well MW-203 had a concentration of sulfate two orders of magnitude higher than the wells at either end of the shoring wall and a concentration of methane one order of magnitude and lower. The carbon dioxide concentration in well MW-203 was approximately one-third to one-half the concentration in wells MW-200, MW-201 and MW-204 and one order of magnitude lower than well MW-205. Geochemical parameter concentrations are shown on Figure 7.

The shoring wall changes the distribution of dissolved-phase petroleum-hydrocarbon concentrations and geochemical parameters at the site. This shows that dissolved-phase COCs and electron acceptors do not flow directly toward Elliott Bay if upgradient of the shoring wall and appear to be routed around the wall. In addition, the shoring wall may promote tidal influence inland by locally blocking groundwater flow along the natural gradient toward Elliott Bay, subsequently improving the distribution of sulfate for biodegradation delivered further inland.

Relatively high concentrations of sulfate (an electron acceptor) and low concentrations of degradation byproducts (methane, carbon dioxide, Mn(II), Fe(II)) in wells MW-202, MW-206 and MW-207 indicate that natural attenuation processes are occurring much slower or not at all near these wells, in addition to receiving sulfate-rich saltwater during tidal fluctuations.

Geochemical parameter concentrations detected in monitoring wells in the Offsite Area are consistent with tidal influence previously observed at the site and exhibit trends consistent with those generally associated with localized dissolved-phase petroleum hydrocarbon impacts. These trends generally include lower concentrations of electron acceptors (DO, nitrate, Mn(IV), Fe(III), sulfate and carbon dioxide) and elevated concentrations of byproducts (carbon dioxide, Mn(II), Fe(II), sulfide and methane) in

areas of petroleum hydrocarbon impacts compared to background concentrations. Geochemical parameter data are summarized in Tables 6 and 7 and on Figure 7.

4.2 Capacity for Intrinsic Biodegradation of Petroleum Hydrocarbons

The capacity for naturally occurring in-situ biodegradation processes to remediate site groundwater impacted with COCs was evaluated using a mass-balance approach based on the stoichiometric demand of sulfate relative to COC concentrations. The results of this evaluation indicate that there is excess capacity for naturally occurring in-situ biodegradation processes, specifically sulfate reduction, to remediate groundwater. In other words, groundwater at the site has a natural excess of sulfate relative to the concentrations of site COCs. The methods and results of this evaluation are described below.

To estimate the capacity for biodegradation of petroleum hydrocarbons at the site, sulfate concentrations detected in site groundwater are estimated to support the biodegradation stoichiometric consumption rate of 0.19 gram of hydrocarbon per gram of sulfate for decane (Johnson et al. 2006). Decane is assumed to be the representative proxy for site COCs and the derivation for this value is shown in Appendix E. This value indicates that 1 gram of sulfate could potentially be used to biodegrade 0.19 gram of decane-equivalent hydrocarbons.

Using this stoichiometric consumption rate, capacities for natural attenuation via sulfate reduction were estimated based on concentrations detected in groundwater samples. Capacities ranged from 0 to 342,000 micrograms of hydrocarbon per liter ($\mu\text{g-HC/L}$). The wells with the largest remaining capacity were MW-202, MW-203, MW-206 and MW-207, which have the greatest influence from saltwater and are furthest downgradient. These calculations provide an estimate and do not account for sulfate consumption via natural processes. Conversely, they only measure remaining sulfate reduction capacity and do not include potential capacity from other metabolic processes. Due to low or no detections, DO and nitrate concentrations were not used for comparison.

Calculations were completed as shown in Appendix E. Capacities for natural attenuation are summarized below:

Former Unocal Seattle Marketing Terminal
3001 Elliott Avenue
Seattle, Washington

Well	Groundwater Capacity for Biodegradation (µg-HC/L)
MW-200	3,990
MW-201	1,007
MW-202	176,700
MW-203	169,100
MW-204	0
MW-205	1,425
MW-206	342,000
MW-207	266,000
MW-30	34,200

During the second semiannual monitoring event, a concentration of 2,800 micrograms per liter (µg/L) TPH, the sum of detectable TPH-G, TPH-D and TPH-O concentrations was present in the sample collected from well MW-204. TPH-G in the groundwater and excess capacity up to 342,000 µg-HC/L in the Offsite Area contains a natural supply of sulfate sufficient to biodegrade dissolved-phase hydrocarbon concentrations via sulfate reduction.

5. Piezometer Installation

To evaluate potential near-well head losses that may occur during the single-well hydraulic conductivity testing, ARCADIS installed two piezometers near Offsite Area monitoring wells MW-203 and MW-204 on June 1 and June 28, 2010. Also, ARCADIS installed piezometer PZ-61A-R near Elliott Avenue well MW-61A-R to monitor surfactant injection/extraction operations, collect site-specific geological parameters for the LNAPL mobility study and evaluate potential near-well head losses that may occur during the single-well hydraulic conductivity testing.

5.1 Offsite Area Piezometer Installation

The two piezometers located near monitoring wells MW-203 and MW-204 were labeled PZ-203 and PZ-204, respectively. The locations of piezometers PZ-203 and PZ-204 are shown on Figure 11. These areas were chosen for piezometer installation because they are located in the newer fill material, which was placed during the 2005 “hot-spot” excavation, and in the Offsite Area older fill material, respectively.

Piezometer PZ-204 was cleared using a vacuum truck to 8 feet bgs on June 1, 2010. Piezometer PZ-203 was cleared to 3.5 feet bgs on June 1, 2010 and continued to 8 feet bgs on June 28, 2010 due to a layer of asphalt encountered in the borehole at 3.5 feet bgs. Due to the inability of a direct-push drill rig to penetrate the subsurface, a hollow-stem auger drill rig was used to advance the boreholes and complete the piezometer installations.

At Ecology’s request, piezometers PZ-203 and PZ-204 were continuously logged to the final borehole depths by the supervising ARCADIS geologist using the United Soil Classification System (USCS) method. Field screening of soil samples was performed continuously during drilling activities using a photo ionization detector (PID) and visual classification. Soils from each split spoon sampler were placed into a sealable plastic bag and allowed to volatilize for at least 10 minutes, but no more than 60 minutes. A PID was then inserted into a small opening of the plastic bag and used to read the level of volatile organic compounds (VOCs) in the bag. The VOC readings were recorded on the boring logs used to document drilling activities (Appendix F). Collection of soil samples was requested by Ecology via e-mail dated May 18, 2010 (Ecology, pers. comm. 2010a). Soil samples were collected at 5-foot intervals and submitted to TestAmerica in Tacoma, Washington for analysis of:

- TPH-G by method Northwest Total Petroleum Hydrocarbon method for volatile petroleum products (NWTPH-Gx)
- TPH-D and TPH-O by method Northwest Total Petroleum Hydrocarbon method for semivolatile petroleum products (NWTPH-Dx; with silica gel cleanup)

The boreholes for piezometers PZ-203 and PZ-204 were completed to final depths of 20 and 35.5 feet bgs, respectively. Soils observed in the borings generally confirm previous field observations and the soils observed in the top 8 feet of boring PZ-203 were classified as dense by the ARCADIS field geologist.

The piezometers were constructed of 1-inch schedule 40 polyvinyl chloride (PVC). The PVC casing for piezometer PZ-203 was set at 20 feet bgs with a 15-foot, 0.020-inch screened interval extending to 5 feet bgs. The PVC casing for piezometer PZ-204 was set at 30 feet bgs with a 15-foot, 0.020-inch screened interval extending to 15 feet bgs. The piezometers were completed with #2/12 silica sand, hydrated bentonite chips and a flush-mounted, traffic-rated monument set in concrete. Boring logs for piezometers PZ-203 and PZ-204 are included in Appendix F.

5.2 Elliott Avenue Piezometer Installation

On May 26 and 27, 2010, boring location PZ-61A-R was cleared using a vacuum truck and manual methods to a depth of 7 feet bgs. Soil samples were collected during boring pre-clearance using a hand auger. A limited access hollow stem auger drill rig was then used to advance the boring from 7 feet bgs to its final depth of 30 feet bgs. Samples were field-screened using a PID and classified using the USCS method by an ARCADIS field geologist.

Undisturbed soil core samples were continuously collected from a depth of 10 to 19 feet bgs for analysis of site-specific petrophysical data for incorporation into the LNAPL mobility study. The soil core was collected in 6-inch brass tubes, which were removed from the split-spoon sampler, capped with Teflon[®]-lined plastic caps on each end and sealed with duct tape. The tubes were then labeled and immediately packed on dry ice in a vertical position to preserve the pore fluids and the pore space geometry. Field screening and USCS classification was not completed during core sample collection due to the nature of the sampling method.

From a depth of 19 feet bgs to completion of the boring at 30 feet bgs, continuous logging and sampling of the boring was conducted via split-spoon samplers. Samples

were continuously collected, field screened and logged. Samples were collected for chemical analysis at depths of 5, 9, 19.5, 25 and 30 feet bgs and were placed into clean, laboratory-supplied containers with appropriate preservatives, and then sealed, labeled and stored on ice. The samples were submitted under proper chain of custody procedures to TestAmerica of Tacoma, Washington, for the following analyses:

- TPH-G by method NWTPH-Gx
- TPH-D by method NWTPH-Dx

Samples from 5, 25 and 30 feet bgs were not analyzed due to low PID headspace readings and no observed visual impacts.

Boring PZ-61A-R confirmed the interbedded nature of soils in the area. In addition, soils encountered were classified as very dense, with decreasing density toward the bottom of the boring at approximately 30 feet bgs.

Upon completion of the boring installation, PZ-61A-R was constructed of Schedule 40 2-inch PVC well casing with 20 feet of 0.02-inch slotted screen extending from 30 to 10 feet bgs. The sand pack was constructed of 22 feet of #2/12 silica sand extending from 30 to 8 feet bgs. Hydrated bentonite chips were used as backfill from 8 to 3 feet bgs. The boring was completed with 3 feet of concrete and a steel flush-mounted well monument. The boring log for piezometer PZ-61A-R is included in Appendix F.

5.3 Piezometer Installation Analytical Results

The Order and subsequent amendments do not establish soil cleanup levels for the Offsite Area or Elliott Avenue Area. For comparison, soil analytical data collected are compared to MTCA Method A soil cleanup levels for unrestricted land use (Ecology 2007a). Laboratory analysis for BTEX compounds was not conducted; therefore, based on historical groundwater monitoring data from monitoring wells MW-204 and MW-61A-R, soil cleanup levels for gasoline with benzene are used for comparison. Soil analytical data are summarized in Table 8 and the analytical laboratory report is included in Appendix G.

5.3.1 Offsite Area

Soil samples were collected from boring PZ-203 at 5-foot intervals from 5 to 20 feet bgs. A TPH-G concentration of 55 mg/kg, which exceeds the MTCA Method A soil cleanup level of 30 mg/kg, was detected at a depth of 15 feet bgs. This depth is

immediately below the area where residual COCs were smeared across the soil when the water table fluctuated between the historical high and low water table elevation (i.e., the groundwater smear zone). TPH-G was detected below the cleanup level in the soil sample collected from 20 feet bgs. TPH-D was detected below the cleanup level in the soil samples collected from 15 and 20 feet bgs. TPH-O was detected in each of the four samples collected from boring PZ-203 below the MTCA Method A soil cleanup level. The concentrations of TPH-O above the smear zone may indicate residual concentrations from the hot-spot excavation activities completed in 2005. The soil reuse criteria for TPH-O was 2,000 mg/kg, which is equivalent to the MTCA Method A soil cleanup level, and clean excavated soils combined with clean imported fill were used to backfill approximately the top 12 feet of the excavation (GeoEngineers 2006a).

Soil samples were collected from boring PZ-204 at approximately 5-foot intervals from 5 to 35 feet bgs. Wet soil was noted at 19 feet bgs in the boring and the corresponding soil sample at that depth contained TPH-G and TPH-D concentrations of 3,200 and 2,600 mg/kg, respectively. Both concentrations exceed their respective MTCA Method A soil cleanup levels of 30 and 2,000 mg/kg, respectively. TPH-G concentrations exceeding the cleanup level were detected in samples from 25, 29.5 and 35 feet bgs, while the concentration of TPH-D detected in the soil sample from 25 feet bgs exceeded the soil cleanup level. TPH-O was detected below cleanup levels in the soil samples from 19 and 25 feet bgs. Soil analytical data are summarized in Table 8.

5.3.2 Elliott Avenue Area

Two soil samples were collected during installation of piezometer PZ-61A-R. The sample collected from a depth of 9 feet bgs did not contain detectable concentrations of TPH-G, TPH-D or TPH-O. The sample collected from a depth of 19.5 feet bgs did not have detectable concentrations of TPH-D or TPH-O, but a TPH-G concentration of 43 mg/kg was detected, exceeding the MTCA Method A soil cleanup level of 30 mg/kg. Groundwater levels are approximately 13 feet below top of casing in well MW-61A-R. Soil samples for COC analysis were not collected between 9 and 19.5 feet bgs because an undisturbed soil core was collected from this interval and submitted for analysis for site-specific geological parameters as part of the LNAPL mobility analysis presented in Section 9. Soil analytical data are summarized in Table 8.

6. Well Development

Upon completion of piezometer installation activities, the three new piezometers and wells MW-200 through MW-203 and MW-205 through MW-207 were redeveloped by surging the wells and purging groundwater containing entrained sediment. Development and redevelopment activities were completed more than 48 hours after installation and prior to hydraulic conductivity testing. A weighted Teflon bailer was used to surge each well and remove sediments built up in the bottom of the well. A peristaltic pump was then used to complete development. Well development field notes are included in Appendix H.

6.1 New Piezometer Development

Development activities for piezometer PZ-203 were completed using a weighted bailer for surging and a peristaltic pump for purging on July 21, 2010. Approximately 4.2 gallons of groundwater were purged from the well after an initial surging and an additional 2.1 gallons were purged after a second surging. Field notes indicate that after 4.2 and 5.8 gallons of total purging, the groundwater was clear by visual observation.

Development of PZ-204 was completed on July 20 and August 11, 2010. Due to the greater depth of groundwater in the well, a weighted bailer was used for both surging and purging activities instead of a peristaltic pump due to the greater depth of groundwater in the well and the pump's operational limitations. On July 20, 2010 approximately 4.5 gallons of groundwater were purged from the well. Due to time limitations, purging was discontinued for the day even though the groundwater remained very silty per visual observation. On August 11, 2010 piezometer PZ-204 was surged and an additional 5 gallons of groundwater were purged. Although more than 20 well volumes were purged from PZ-204, groundwater remained turbid by visual observation.

Piezometer PZ-61A-R was developed on July 19, 2010. Approximately 28 gallons of groundwater were purged from the well following surging activities. Visual observations indicate that the water was clear upon completion of purging. Table 9 summarizes piezometer development activities.

6.2 Existing Monitoring Well Redevelopment

Monitoring wells MW-200 through MW-203 and MW-205 through MW-207 were redeveloped to remove particulate matter from the wells that may be responsible for lingering cPAH concentrations in the wells. Well MW-30, MW-61A-R, MW-204, RW-3 and RW-21 were not included in the scope of work because of multiphase extraction operations were completed on these wells in 2009 (ARCADIS 2010e).

Redevelopment activities were completed on July 21, 2010 and on August 11, 12 and 13, 2010. Between 3 and 10 gallons were purged from each well after surging activities were completed. Sheen was observed on the purge water from wells MW-200 and MW-201. Table 9 summarizes the well redevelopment activities.

7. Surfactant-Enhanced LNAPL Recovery Pilot Testing

To assess persistent measureable LNAPL observed during groundwater monitoring, a surfactant-enhanced LNAPL recovery pilot test was performed on monitoring well MW-61A-R. Previous multiphase extraction operations conducted on well MW-61A-R in 2009 were not successful in permanently eliminating the accumulation of LNAPL in the well (ARCADIS 2010e).

7.1 Injection Methods

Prior to initiating injections, ARCADIS procured an Underground Injection Control authorization from Ecology to conduct the surfactant injection. Approximately 200 gallons of 4 percent solution of the Gold Crew Release[®] surfactant were gravity fed into monitoring well MW-61A-R. The solution was stored in a 400-gallon, steam-cleaned polyethylene tank provided by ClearCreek Contractors of Everett, Washington. The tank was secured in the bed of a 1-ton pickup truck and parked next to the injection well.

The 4 percent Gold Crew Release solution was mixed onsite with potable water from a municipal water supply. A 1-inch-diameter hose was connected to a valve at the bottom of the tank and to a manifold equipped with a pressure gauge to monitor for pressure buildup in the well, flow control valve and flow meter. The hose was then connected to the wellhead adapter, consisting of 1-inch PVC pipe fitted through a 2-inch cap and sealed with a 2-inch rubber fitting. A 1-inch-diameter PVC stinger tube extended from the wellhead adapter to the screened interval of the well at a depth of approximately 14.5 feet bgs. The PVC stinger was capped and four ¼-inch holes were drilled around the piping to allow for sufficient pressure buildup to maintain full-pipe flow through the pipe to minimize turbulence and to reduce sudsing of the solution within the well during injection. Specific conductivity of the injection solution was measured to be 589 microSiemens per centimeter ($\mu\text{S}/\text{cm}$), while ORP was 53 mV. Ambient specific conductivity measurements were 1,053, 1,232 and 2,932 $\mu\text{S}/\text{cm}$ in wells MW-30, MW-61A-R and PZ-61A-R, respectively.

7.2 Injection Monitoring

Prior to injection, a Level Troll 200 pressure transducer was installed in MW-61A-R to measure water level response at the injection well. Approximately 5 feet of mounding was measured in the injection well (Figure 12). The level of mounding was sufficient for surfactant solution to contact the vertical extent of the smear zone near the borehole.

To log specific conductivity and ORP in well MW-30 and piezometer PZ-61A-R during injection, down-hole Troll 9500 water quality meters were installed at approximately the center of the saturated well screen interval. The logging results for well MW-30 are shown on Figure 13 and results for PZ-61A-R are shown on Figure 14. The specific conductivity data collected in well MW-30 varied from approximately 800 to 900 $\mu\text{S}/\text{cm}$, while ORP ranged from approximately -240 to -280 mV. The probe was installed approximately 40 minutes prior to initiating injection on well MW-61A-R and specific conductivity measurements decreased until injections began. Specific conductivity in well MW-30 increased throughout the injection, indicating that groundwater in well MW-30 was influenced due to the injection but not directly by the injection solution. Immediately following injection, specific conductivity measurements became more stable at approximately 800 $\mu\text{S}/\text{cm}$ prior to increasing to approximately 900 $\mu\text{S}/\text{cm}$. Groundwater extraction activities on well MW-61A-R also affected specific conductivity values, but did not cause the data to deviate significantly from the increasing trend.

The specific conductivity and ORP measurements from piezometer PZ-61A-R had a great deal of variation between measurements until several minutes after initiating injection operations. At approximately the time injections began on well MW-61A-R, both ORP and specific conductivity data in PZ-61A-R stabilized and showed little variation prior to removal from the piezometer at approximately 3:00 p.m. on July 21, 2010 following extraction operations. Injections may have affected specific conductivity measurements in PZ-61A-R; however, the baseline data variability prevents any conclusive determination.

Considering that the specific conductivity of the injection solution (590 $\mu\text{S}/\text{cm}$) was significantly less than the pre-injection values observed at PZ-61A-R (1,000 to 3,000 $\mu\text{S}/\text{cm}$, with some readings approaching 10,000 $\mu\text{S}/\text{cm}$), the step decrease in specific conductivity observed after injections began suggests that PZ-61A-R was in direct communication with the injection at MW-61A-R. Additional specific conductivity measurements were taken by hand from MW-61A-R and PZ-61A-R using a YSI-556 water quality meter. Variations in the data may be partially due to where the measurement was taken – directly from the water column with a downhole meter or from the Mason jar samples which were collected using a bailer and then measured with a YSI-556 meter. Specific conductivity measurements are summarized in Table 10.

Baseline specific conductivity of approximately 2,932 and 1,232 $\mu\text{S}/\text{cm}$ was measured in PZ-61A-R and well MW-61A-R, respectively. Parameter measurements collected

immediately after injection decreased to 994 and 1,082 $\mu\text{S}/\text{cm}$ in MW-61A-R and PZ-61A-R, respectively.

Prior to injection, one baseline groundwater sample was collected from each well using a Teflon lined polyethylene bailer and placed in a Mason jar. A shake test was performed on each Mason jar sample to establish baseline sudsing or LNAPL observations. Visible LNAPL was observed in the Mason jar sample from MW-61A-R, but not from PZ-61A-R or well MW-30.

Injection of 197 gallons of surfactant solution commenced at 11:32 a.m. and was completed at 12:52 p.m. During injection, specific conductivity was generally stable in PZ-61A-R. Periodic Mason jar samples were obtained from PZ-61A-R and MW-30. A sample of water from the well was placed in a Mason jar, the jar was capped and shaken, and observations of surfactant or sudsing were noted. Surfactant was not observed in any of the Mason jar samples collected during injection. Field observations are summarized in Table 10.

7.3 Surfactant Extraction

The surfactant solution was allowed to remain in the formation for approximately 24 hours prior to extraction. On July 21, 2010 ARCADIS personnel, along with ClearCreek Contractors and Emerald Disposal Services Washington of Seattle, Washington, returned to the site to remove the surfactant solution from the subsurface. A submersible pump was installed into well MW-61A-R and connected to a flow meter. Pre-extraction conductivity readings and Mason jar samples were obtained from MW-61A-R, PZ-61A-R and MW-30. Mason jar samples collected from well MW-61A-R indicated the presence of surfactant solution through observable bubbles. Bubbles were not observed in the Mason jar samples from PZ-61A-R and MW-30. Specific conductivity measured in wells MW-61A-R and PZ-61A-R was 980 and 885 $\mu\text{S}/\text{cm}$, respectively, which is consistent with measurements taken during injection operations.

Surfactant extraction via pumping began at 10:32 a.m., with the pumping rate ranging from 2.8 to 4.1 gallons per minute (gpm). Conductivity readings and Mason jar samples were obtained from the injection well and the piezometer for approximately every 150 gallons removed. The work plan (ARCADIS 2010a) called for removal of approximately three times the injection volume of surfactant solution; however, the sample obtained from MW-61A-R after extracting 600 gallons still had residual observable sudsing visible in the Mason jar sample. Specific conductivity measurements from the injection well and piezometer were generally stable. To remove the final amount of surfactant

from the well, the down-hole pump was removed and a PVC stinger was inserted into the well and connected to the vacuum truck. The vacuum truck removed an additional 300 gallons of groundwater/surfactant solution and the sample obtained following the extraction of 900 gallons did not contain visible surfactant or LNAPL. Upon completion of extraction operations, specific conductivity readings from MW-61A-R and PZ-61A-R were 972 and 1,240 $\mu\text{S}/\text{cm}$, respectively. Specific conductivity measurements and field observations are summarized in Table 10.

7.4 Surfactant Monitoring Results

Monitoring of well MW-61A-R, piezometer PZ-61A-R and well MW-30 indicates that additional LNAPL has not been mobilized and surfactant has not migrated beyond the near borehole radius of the injection well. LNAPL was not observed in piezometer PZ-61A-R prior to or after injection and extraction activities. Monitoring was completed weekly for the first month after extraction. After weekly monitoring was completed, monthly monitoring was initiated and is ongoing. Monitoring includes taking depth to water and depth to LNAPL measurements in each well, and collecting Mason jar samples and conductivity measurements.

On August 5, 2010, conductivity measurements in well MW-61A-R and piezometer PZ-61A-R dropped to 568 $\mu\text{S}/\text{cm}$, or approximately one-half of the range of previous measurements. This deviation from previous measurements was confirmed during the August 18, 2010 field visit. While specific conductivity measurements are now similar to the injection solution, they are also similar to the baseline specific conductivity measured in well MW-30 on April 14, 2010. Also, Mason jar samples were collected for visual inspection during each monitoring event and suds were not observed.

During the monitoring event on November 19, 2010, the specific conductivity measured in well PZ-61A-R was 384 $\mu\text{S}/\text{cm}$, while the specific conductivity measured in well MW-30 was 549 $\mu\text{S}/\text{cm}$. No measurement was taken from well MW-61A-R because LNAPL was present in the well. Mason jar samples confirmed there were no bubbles in wells MW-61A-R and MW-30; however, LNAPL was measured in well MW-61A-R at a thickness of approximately 0.11 foot. Between August and November 2010, specific conductivity in well MW-30 dropped from 1,081 to 549 $\mu\text{S}/\text{cm}$. Also, groundwater elevations in the well have increased approximately 1.7 feet. Specific conductivity measurements have remained below baseline values in MW-61A-R and PZ-61A-R; however, they have also dropped below the 4 percent surfactant solution specific conductivity and the specific conductivity measured in well MW-30 on April 14, 2010. It appears that specific conductivity trends are related to groundwater elevations in the

Elliott Avenue Area and the drop of specific conductivity measured is due to natural groundwater fluctuations and not pilot testing activities. Specific conductivity measurements and field observations are summarized in Table 10.

7.5 Surfactant-Enhanced LNAPL Recovery Pilot Test Conclusions

Baseline specific conductivity data are highly variable and it is difficult to make conclusive determinations on tracking the movement and recovery of injected solution based on these measurements. The shake tests and observations of sudsing are the most definitive indicator of tracking distribution and recovery of the injected dilute surfactant solution. Observations collected so far indicate recovery of the injected surfactant solution. On October 11, 2010, LNAPL had once again accumulated in well MW-61A-R; however, LNAPL has never been observed in piezometer PZ-61A-R, which is installed less than 5 feet from MW-61A-R and is screened across the same interval. Long-term monitoring of LNAPL thicknesses in MW-61A-R is required to determine if LNAPL accumulation is less than historical rates. While LNAPL has not migrated in well PZ-61A-R, it was approximately 2 years between installation and the first observation of LNAPL well MW-61A-R. While it is possible that LNAPL will migrate into well PZ-61A-R, MW-61A-R is representative of conditions in the area and PZ-61A-R should be abandoned after completion of surfactant monitoring activities. Also, it is possible that PZ-61A-R lies outside of the LNAPL plume or MW-61A-R is between the LNAPL source zone and the piezometer, providing a high conductivity sink so LNAPL will not reach the piezometer.

8. Hydraulic Conductivity Testing

In August and September 2010, ARCADIS conducted three step drawdown pumping tests and 13 constant rate pumping tests to assess groundwater flow and geologic heterogeneities at the site. Five of the wells had observation wells located close enough to monitor drawdown. Single-well pumping tests were performed on the remaining seven wells. Pumping tests were scheduled so that adjacent wells were not pumped until static conditions were observed in the test well and associated monitoring wells.

8.1 Oil-Water Separator Maintenance

Prior to hydraulic conductivity testing, the onsite oil-water separator was cleaned and reconditioned to allow for efficient disposal of water generated at the site during pumping test activities. Maintenance activities were completed by ClearCreek Contractors under the supervision of ARCADIS field staff. Activities included steam-cleaning the oil-water separator, replacing piping leading from the oil-water separator to the LNAPL recovery tank, and installing a new, inline flow meter to monitor water discharge to the King County municipal sewer system. Discharge was conducted and reported in accordance with King County Industrial Waste Program under Permit No. 529-03.

8.2 Pumping Tests

Pumping tests were conducted using a Grundfos® Redi-Flo 2 submersible pump and controller. Reusable equipment was decontaminated prior to use at each test location. Wastewater generated during the testing was transferred to the onsite oil-water separator and subsequently discharged to the King County sewer system. The wastewater was discharged through authorization of the King County Industrial Waste Program under Permit No. 529-03. Groundwater discharge was measured using an inline flow meter and the recorded volume was occasionally spot-checked with a graduated container.

8.2.1 Step Drawdown Testing Field Methods and Results

To assess the potential yield of site monitoring wells, step drawdown testing was performed on wells MW-61A-R, MW-203 and MW-204. Testing activities for monitoring wells MW-203 and MW-204 were conducted to account for the peak of the tidal cycle observed during the August 2009 tidal study. Pumping wells and piezometers were

gauged with an oil-water interface probe prior to installation of the submersible pump. Before each test, pressure transducers (Level Troll 700) were placed in newly installed piezometers (PZ-61A-R, PZ-203 and PZ-204) located approximately 5 feet from the pumping wells. After installation of the submersible pumps and data loggers, the groundwater level in the test well and piezometers was allowed to equilibrate and periodic groundwater levels were measured prior to the start of each test. Additional manual depth to groundwater measurements were obtained from the piezometers to convert the height of the groundwater column above the level logger to depth to groundwater measurements. Water levels during each flow rate step were measured manually on a logarithmic frequency during testing as noted in the table below.

Elapsed Time (Minutes)	Interval Between Water Level Measurements (Minutes)
0 to 5	1
6 to 15	2
16 to 30	5

Step drawdown test results were analyzed to evaluate well efficiency, to determine appropriate pumping rates for the three different geological areas specified in the work plan (ARCADIS 2010a) (the Offsite Area – 2005 excavation backfill, the Offsite Area – native fill and the Elliott Avenue Area), and to determine if area-specific well-loss correction factors were necessary to complete test data analysis. Due to the significant difference in the pumping rates required to sufficiently stress well RW-3, compared to the other Offsite Area wells, one additional step drawdown test was conducted on well RW-3.

During the proposed constant rate pumping test at well RW-3, the well dewatered at a significantly lower extraction rate than anticipated. To determine an appropriate pumping rate that would sufficiently stress the well, an additional step drawdown test at RW-3 was performed outside of the proposed scope of work. Step drawdown testing was conducted for approximately 30 minutes at each flow rate. Pumping rates for the step drawdown tests in each well were as follows:

- MW-61A-R.* Using historical vacuum extraction data, the theoretical maximum pumping rate was estimated to be 4 gpm. Step drawdown testing was planned at 5 percent (0.2 gpm), 33 percent (1.3 gpm), 66 percent (2.6 gpm), 100 percent (4 gpm) and 133 percent (5.3 gpm) of the theoretical pumping rate. The actual

maximum sustained pumping rate determined from step test data was 4.2 gpm. Pressure transducer data were collected from PZ-61A-R and MW-30.

- *MW-203.* Using historical sampling purge data, the theoretical maximum pumping rate was estimated to be 1.3 gpm. Step drawdown testing was planned at 5 percent (0.1 gpm), 33 percent (0.4 gpm), 66 percent (0.85 gpm), 100 percent (1.3 gpm) and 133 percent (1.7 gpm) of the theoretical pumping rate. However, limited drawdown was observed during the step drawdown test. A pumping rate of 5 gpm was selected to stress the well during constant rate testing. Pressure transducer data were collected from PZ-203 and MW-204.
- *MW-204.* Using historical sampling purge data the theoretical maximum pumping rate was estimated to be 1.35 gpm. Step drawdown testing was planned at 5 percent (0.1 gpm), 33 percent (0.45 gpm), 66 percent (0.9 gpm), 100 percent (1.35 gpm) and 133 percent (1.8 gpm) of the theoretical pumping rate. Similar to the test at well MW-203, limited drawdown was observed during the test and a pumping rate of 5 gpm was selected to stress the well during constant rate testing. Pressure transducer data were collected from PZ-204 and MW-205.
- *RW-3.* The step drawdown test was conducted on August 16, 2010 after allowing groundwater elevations to stabilize in the well after the initial constant rate pumping test. Using data from the constant rate test attempt, the theoretical maximum pumping rate was estimated to be 1.3 gpm. Step drawdown testing was therefore planned at 15 percent (0.2 gpm), 35 percent (0.45 gpm) and 55 percent (0.7 gpm). However, a pumping rate of 0.7 gpm did not produce sustainable drawdown and no additional tests were done. A pumping rate of 0.4 gpm was estimated to adequately stress wells RW-3 and RW-21 during constant rate testing. Pressure transducer data were collected from well RW-2.

Well efficiency is an indicator of the ability of a pumping well to provide accurate potentiometric level measurements under pumping conditions. Under relatively high pumping rates, excess drawdown may be observed in a well due to turbulent flow conditions that develop in the water-bearing zone immediately adjacent to the well and across the well screen and filter pack. Under relatively low pumping conditions, excess drawdown in the pumping well may be minimal or even negligible due to a lack of turbulent flow conditions. Well efficiency can be evaluated by performing step drawdown pumping tests at a well and estimating the specific capacity of the well under variable pumping rates. Specific capacity is defined as the pumping rate per unit of drawdown in a pumping well at a given pumping rate.

The relationship between pumping rate and specific capacity under variable pumping rates can indicate the extent of turbulent flow and excess drawdown in a pumping well, and can be used during the analysis of constant-rate pumping tests if turbulent flow is deemed important. Under turbulent flow conditions at a pumping well, the observed water level in the well will be lower than in the water-bearing zone, and evaluation of well efficiency may indicate if groundwater flow into the well is turbulent or laminar (Darcian) and thus independent of frictional losses from water crossing the filter pack and well screen.

The step drawdown tests conducted at MW-61A-R and RW-3 were evaluated to assess the well efficiency at these locations. The efficiency of monitoring well MW-204 could not be reliably estimated because the pumping water level in the well actually rose during pumping in response to tidal influences during the test. The incoming tide over-printed or damped the pumping response and the resulting data could not be relied on to assess well efficiency. Furthermore, the efficiency of monitoring well MW-203 could not be reliably estimated because there was insufficient drawdown in the pumping well, even at the maximum pumping rate. The step drawdown testing data are included in Appendix I.

The step drawdown pumping tests performed at well MW-61A-R and RW-3 yielded useful results. The data showed that at these wells there was an approximately linear correlation between specific capacity and pumping rate, with correlation coefficient (R^2) values of 0.98 for each test (Appendix I). This information indicates that the range of pumping rates used at these wells did not produce non-linear turbulent flow conditions, and that drawdown in the wells during the pumping tests was primarily a function of the prevailing groundwater hydraulics. These results were used to evaluate hydraulic properties of the water-bearing zone of interest.

The step drawdown test data and results were primarily used to select target pumping rates during constant rate testing. A pumping test well correction factor for each area was not calculated due to either insufficient data or lack of significant turbulent flow under the selected pumping rates. Specifically, relatively low pumping rates were selected for the constant-rate tests to minimize the hydraulic stress at the pumping well and to negate the effects of turbulent flow across the well screens. This is shown by the results summarized in Section 8.4 and the graphical plots of groundwater drawdown data in the pumping wells included in Appendix I.

8.2.2 Constant Rate Pumping Tests

Short-duration constant rate pumping tests were conducted at the site to estimate the hydraulic conductivity of the geologic formation near each test well. Each test was conducted according to the work plan (ARCADIS 2010a) and addendum (ARCADIS 2010b) and involved pumping groundwater from a well at a constant rate for approximately 45 minutes and quantifying the pumping rate and magnitude of drawdown inside the tested well. Constant rate testing was performed on monitoring wells MW-30, MW-61A-R, RW-3, RW-21 and MW-200 through MW-207. Due to tidal influence observed in wells MW-200 through MW-207 and RW-3, constant rate tests were performed at peak high tide to minimize tidal effects on the time-drawdown data. Optimum pumping test times were planned for approximately 22.5 minutes prior to and 22.5 minutes following peak high and low tidal conditions and the timing of each test estimated using lag times based on data collected during the 2009 tidal study. The lag time was used to estimate the corresponding timing of the high and low groundwater elevations in each test well. The majority of the tests were performed at the peak (high point) of the tidal cycle. Additional constant rate tests were performed at low tide for monitoring wells MW-203 and MW-204. Constant rate pumping test details are summarized in Tables 11 and 12.

Groundwater levels were measured periodically in the pumping well for up to 2 hours prior to the start of each test, during the test and for 1 hour following the test. Water levels during the constant rate tests were measured using an oil-water interface probe on a logarithmic frequency during pump operation and following pump shutdown as noted in the table below.

Elapsed Time (Minutes)	Interval Between Water Level Measurements (Minutes)
0 to 5	0.25
5 to 10	0.5
10 to 30	1 to 2
30 to 45	2 to 5

At several wells, timing intervals were adjusted based on well equilibration. Additional groundwater elevation data were collected using a Level Troll 700 deployed in nearby piezometers or monitoring wells as proposed in the addendum (ARCADIS 2010b). Pressure transducer data collection intervals are listed in Table 11. During the test on well MW-204, well RW-7 was not used to monitor drawdown in the water-bearing zone

as specified in the addendum (ARCADIS 2010b). Due to the distance between wells MW-204 and RW-7 that field staff would have had to travel and the associated logistical problems for collecting data, MW-205 was substituted for well RW-7.

8.3 Constant Rate Pumping Test Data Analysis

To separate the effects of pumping on water levels from effects due to tidal changes, pretest and post-test water levels were analyzed. Both pretest and post-test water-level trends were analyzed to characterize regional water level trends that may have been occurring during the test due to tidal fluctuations. In some cases, water levels were corrected during data analysis using the results of the tidally influenced water levels. During several pumping tests, insufficient drawdown was observed in pumped and/or observation wells; therefore, no analysis of these datasets was completed. Tables 11 and 12 summarize the well network, pumping rates and details on impediments to analysis for the datasets not analyzed.

Constant rate pumping test data were analyzed using AQTESOLV[®], which is a software package that can be used to estimate transmissivity and storage parameters from pumping test data. Wells MW-30, MW-61A-R, MW-200 through MW-202, MW-204 through MW-207, RW-3 and RW-21 were analyzed using the Theis (1935) solution for unconfined aquifers. This method provides an exact analytical solution for unsteady flow in an aquifer where there is no time-dependent storage. The software was used to evaluate the best fit of the analytical solution to observed data and back-calculate the hydraulic properties of the water-bearing zone. To estimate hydraulic conductivity of the saturated soils immediately surrounding the test wells, the saturated thickness of the tested zone was assumed to be the thickness of the water-bearing zone immediately adjacent to the well screen. The measured time-drawdown data were fit to the analytical solution by adjusting parameters until an optimal match was obtained.

Three constant rate pumping tests were conducted on well MW-203 to estimate hydraulic conductivity of soils near that well, but the data were deemed to be unreliable for a variety of reasons. For example, during one test the field staff encountered operational problems with the submersible pump and could not maintain a constant pumping rate. During a second test, there was insufficient drawdown in the pumping well at the selected pumping rate. During the third test, the time-drawdown data were significantly influenced by tidal fluctuations and the data were not usable. While the majority of the constant rate tests were performed during the increasing or decreasing phase of the tidal cycle and the resulting data could be reliably corrected, the MW-203

test occurred as the tide shifted from high to low tide, creating uncertainty in the calculated lag time between the tidal cycle and the corresponding groundwater level change in the well. Nonetheless, because minimal drawdown was observed at well MW-203, the hydraulic conductivity in that area is expected to be greater than the hydraulic conductivity values estimated at wells MW-206 and MW-207, where drawdown was observed as a result of similar discharge rates.

The effect of tidal influence on observed groundwater levels during the remaining constant rate pumping tests was evaluated using the pretest and post-test pressure transducer data. Data were collected up to 2 hours prior to the start of each test, during the test and for 1 hour following each constant-rate pumping test. Time-series trends were compared to determine shifts in the rate of background groundwater level changes. The slope of the tidally induced water level changes through time was quantified and the observed data during the pumping test and recovery were corrected accordingly. During some pumping tests, tidal influences were negligible and no corrections were used. Tidal influence corrections were applied to datasets collected at wells MW-200, MW-201, MW-202, MW-204 (high tide), MW-204 (low tide), MW-205, MW-206 and MW-207. Transient water level fluctuations were observed at observation wells during the constant rate pumping tests performed at wells MW-30 and RW-21. While it is likely that transient groundwater fluctuations observed during the RW-21 test are due to tidal fluctuations, it is not clear what caused the transient groundwater fluctuation during the MW-30 test. Tidal and transient influence corrections are summarized in Table 11.

8.4 Constant Rate Pumping Test Results

Results show that hydraulic conductivity values (K-values) estimated from the pumping test datasets varied between approximately 0.3 foot/day at well RW-3 and 430 feet/day at well MW-206. The K-values were generally consistent with the texture of different saturated soil units present at the site (i.e., the Offsite Area – 2005 excavation backfill, the Offsite Area – native fill and the Elliott Avenue Area). These K-values also coincide with values expected from materials as described in the site boring logs. These boring logs indicate that a dominant portion of the water-bearing zone consists of heterogeneous fill soils. Constant rate pumping test results are summarized in Table 12.

In the Elliott Avenue Area, calculated K-values varied between approximately 1.7 and 9.2 feet/day. These results are expected for the poorly sorted sands found in the Elliott Avenue Area.

In the Offsite Area (which contains native fill) K-values estimated for most of the pumping tests varied between approximately 0.3 and 39 feet/day. However, higher K-values were estimated for the datasets collected at Offsite Area wells MW-202 (140 feet/day), MW-206 (430 feet/day) and MW-207 (200 feet/day). These locations with the highest K-values also correspond with the highest levels of saltwater intrusion that were observed in previous groundwater studies (ARCADIS 2010c). These results reflect the highly heterogeneous nature of saturated soils in and around the Offsite Area between wells nearest to Elliott Bay (MW-202, MW-206 and MW-207), in the 2005 excavation footprint (MW-202 and MW-203) and in the remaining wells within the native fill (MW-200, MW-201, MW-204, MW-205, RW-3 and RW-21). The relatively high hydraulic conductivity values observed at wells screened in the poorly sorted, sandy fill material both from the 2005 excavation and the older native fill in the Offsite Area are likely due to the presence of poorly consolidated fill deposits.

Derived storativity values for observation wells based on the time-drawdown data showed little variation, with values varying between approximately 0.004 and 0.02, which is indicative of unconfined to semiconfined groundwater conditions (Appendix J). While these values are low for the specific yield of unconfined water-bearing zones, they are not atypical of values determined by short duration tests. Specific yields of the water-bearing zones under longer-term pumping might be expected to be higher.

The K-values measured at wells MW-204 and PZ-204 during the high tide test at well MW-204 were approximately equal, indicating a high degree of well efficiency; therefore, evaluation of well loss correction factors was not performed. Similarly, the pumping test performed at well MW-204 under low tide conditions yielded similar results to the K-values measured at MW-204 and PZ-204 under high tide conditions (the difference was approximately 0.3 foot/day or 21 percent). The K-values measured at wells MW-61A-R and PZ-61A-R differed by approximately a factor of two. The datasets for this test indicated the presence of a potential recharge boundary or soil heterogeneity and are therefore suspect. Nonetheless, these results indicate good reproducibility in terms of both field implementation and data analysis methods.

Pumping test results for wells RW-3 and RW-21 demonstrated that the hydraulic conductivity of saturated soils in the Offsite Area near the railroad tracks appears to be at least one order of magnitude lower than hydraulic conductivity values measured in soils near the rest of the Offsite Area wells. This is due to the heterogeneity and compaction of the different native fill materials used in this area. Also, highly viscous, weathered and immobile LNAPL historically observed in these wells is likely present at residual saturation (defined in Appendix L Section 1.2.2) in soils immediately

surrounding these wells, thereby reducing the effective porosity near the well screens and sand pack and limiting groundwater flow to these wells.

Constant rate pumping tests were completed at well MW-204 to assess the potential difference of K-values derived from tests conducted at the same well during low and high tides. The K-values measured at well MW-204 during high and low tidal tests were 8.4 and 14 feet/day, respectively. This is a relatively minor discrepancy, roughly less than a factor of two, and is likely due to several factors that may be associated with tidal influences, seawater intrusion and resulting groundwater density differences.

The geometric mean of the K-values measured across the entire site is approximately 15 feet/day. The geometric mean of K-values measured at Offsite Area monitoring wells screened in the native fill is approximately 12 feet/day. The geometric mean of the K-values measured at wells in the Elliott Avenue Area is approximately 4 feet/day. The K-value estimated for saturated fill materials within the 2005 excavation footprint is 140 feet/day.

The geometric mean K-value of the native fill Offsite Area soils (i.e., 12 feet/day) should be used for fate and transport evaluations because any groundwater flowing toward Elliott Bay must pass through the native fill of the Offsite Area. Hydraulic conductivity, transmissivity and storage parameters are summarized in Table 12.

The analysis of constant rate pumping tests at the site yielded consistent and reasonable estimates for hydraulic conductivity; estimates for hydraulic conductivity based on the pumping tests are within the published ranges for lithology consistent with each of the areas. A review of the site lithology further confirmed the reliability of estimates provided. Simulated drawdown curves provided reasonable fits to observed data, yielding a high degree of certainty in the derived parameter estimates. The well efficiency of wells MW-61A-R and RW-3 was qualitatively evaluated to validate the appropriateness of using constant-rate pumping test observations in the pumping well to describe the water-bearing zone's response to pumping and the resulting hydrologic parameters. Well efficiency of well MW-203 could not be evaluated due to limited drawdown in the well during pumping. Graphical plots of the data are provided in Appendix I for the step drawdown tests. Each well showed consistent drawdown relationships at various pumping rates, indicating that laminar or Darcian flow dominated the observed water-level responses at all flow rates tested. Constant rate drawdown curves and AQTESOLV-generated plots are included in Appendix J. MW-205 LNAPL Observation

8.5 MW-205 LNAPL Observation

On September 17, 2010, during hydraulic conductivity testing in well MW-205, LNAPL was observed on the tubing upon being removed from the well. Sheen was noted on the oil-water interface probe after gauging events on September 21, but LNAPL was not measured in the well. The gauging event on September 21 was conducted at the tidal lag time corrected low-low tide time for the well. Teflon[®] bailers were subsequently used to visually confirm the presence of LNAPL, and LNAPL was not confirmed as present after the initial observation. Follow up gauging events were conducted beginning September 28 and no indication of sheen or LNAPL was observed during any of these events. It appears that LNAPL sorbed to soil in the vicinity of well MW-205 does not contribute to dissolved-phase COC concentrations. Dissolved phase concentrations in well MW-205 have remained non-detectable since monitoring began with the exception of three detectable TPH-G concentrations which were an order of magnitude less than the RAL.

LNAPL present at or below the residual saturation (defined in Appendix L Section 1.2.2) typically does not pool in monitoring wells. LNAPL residual saturation is higher in the saturated zone compared to the vadose zone where product may be displaced due to gravitational forces. Therefore, when the groundwater elevation decreases, LNAPL may drain from soil pores above the groundwater table and pool in wells. It is likely that the LNAPL observed in MW-205 on September 17 was residual LNAPL that was present in or near the well sand pack. More than 5 feet of water table drawdown was observed during the MW-205 pumping event. The groundwater elevation change likely resulted in some localized LNAPL drainage that was noted in the pumping well during pumping operations. Tidal fluctuations of up to approximately 2.5 feet in MW-205 are routinely observed and LNAPL has not accumulated in the well since it was installed in 2006. Therefore, future LNAPL accumulation under normal tidal conditions is not anticipated (ARCADIS 2010c).

9. Dissolved-Phase COC Fate and Transport Evaluation

The hydraulic conductivity data presented in Section 8 and COC concentrations measured in groundwater samples between May 2009 and April 2010 were used to estimate the potential discharge of COCs (the flux) to Elliott Bay. Several assumptions were made to simplify the calculations:

- Due to the few number of groundwater cleanup level exceedances at the site and to account for variations of concentrations detected in site groundwater samples, ARCADIS conservatively used the maximum concentration of each COC detected in any of the Offsite Area wells between May 2009 and April 2010.
- The location of the sea wall was estimated to be the site boundary and was used to determine the distance from individual wells to Elliott Bay and their respective gradients.
- Average gradient conditions were estimated from historical groundwater monitoring data for each well and hourly Elliott Bay water level data from August 20, 2008 to August 20, 2010.
- Soil porosity was estimated. Effective porosity of the soil is estimated to be 0.2 and the total porosity is estimated to be 0.4. While porosity is variable between geological formations at the site, 0.2 and 0.4 are considered adequate assumptions based on published values (Payne 2008).

This section summarizes the formulas, methods and additional assumptions used to evaluate the fate and transport of COCs to Elliott Bay. The average hydraulic gradient is shown on Figure 15.

9.1 Groundwater Velocity

The geometric mean K-value for Offsite Area native fill soils and Equation 10-1 were used to calculate the average linear velocity of groundwater between each well and the sea wall.

—

Equation 10-1

Where:

i = Hydraulic gradient (average)

K = Hydraulic conductivity (geometric mean)

n_e = Effective porosity (estimated to be 0.2)

v_{gw} = Average linear groundwater velocity

Calculated groundwater velocities between each well and the sea wall are summarized in Table 13. The range of groundwater velocities calculated for the site was 0.6 to 1.9 feet/day. For calculations in the following sections, an average linear groundwater velocity of 1 foot/day was used.

9.2 COC Velocity in Groundwater

Organic compounds are subject to continuous sorbing/desorbing to solid organic carbon that is naturally present in soil during transport in groundwater. This sorption/desorption process slows COC transport through groundwater and affects transport velocity. This affect is quantified by a retardation factor (R) and is specific to a geologic formation and each COC. The retardation factor for each compound is calculated using equation 10-2.

Equation 10-2

Where:

ρ_b = Dry soil bulk density (estimated to be 1.88 kilograms per liter [kg/L] per the sample collected from 17.3 to 17.5 feet bgs from boring PZ-61A-R)

k_{oc} = Soil organic carbon-water partitioning coefficient

f_{oc} = Soil fraction of organic carbon (estimated to be 0.001)

n = Total porosity (estimated to be 0.4)

Using the groundwater velocity and retardation factor, the COC velocity was calculated using Equation 10-3.

$$\text{---} \qquad \qquad \qquad \text{Equation 10-3}$$

Where:

v_{coc} = COC velocity in groundwater

ARCADIS used the COC velocities and distances from the impacted monitoring wells to the sea wall to estimate the time of transport. Retardation factors, corresponding COC velocities and times of transport from each monitoring well to the sea wall are summarized in Table 13.

Compound-specific soil organic carbon-water partitioning coefficient (partitioning coefficient) values used in this assessment were derived from literature sources. Partitioning coefficients for BTEX constituents, benzo(a)anthracene, BaP and dibenzo(a,h)anthracene are presented in MTCA Table 747-1 (Ecology 2007c). Partitioning coefficients for the remaining cPAHs (benzo(b)fluoranthene, benzo(k)fluoranthene, chrysene and indeno(1,2,3-cd)pyrene) are presented in the VLEACH manual (USEPA 1997). Partitioning coefficients for TPH-G, TPH-D and TPH-O were estimated to be the lowest partitioning coefficient for either aliphatic or aromatic compounds with their respective ranges as presented in MTCA Table 747-4 (Ecology 2007c). For example, while partition coefficients range from 800 to 234,000 L/kg for the TPH-G aliphatic portion, the partitioning coefficient for TPH-G is estimated to be 800 for calculations completed in this summary report. Partitioning coefficients are summarized in Table 14.

9.3 First-Order COC Biodegradation Rate Constants and Half-Lives in Groundwater

Biodegradation reaction kinetics at the site are assumed to be first order. Table 14 summarizes biodegradation rates and their corresponding half-lives.

9.3.1 BTEX First-Order Rate Constants and Half-Lives

Literature values for first-order rate constants and half-lives of BTEX compounds were used for discharge calculations for the site. A review of literature values is summarized in Anaerobic Biodegradation of Organic Chemicals in Groundwater: A Summary of Field and Laboratory Studies (Syracuse Research Corporation 1997). Due to the high

concentrations of sulfate detected in groundwater at much of the site and a nondetectable sulfate concentration in well MW-204, the subsurface is assumed to be anaerobic and sulfate-reducing. Thus, the mean first-order anaerobic biodegradation rate constants for sulfate-reducing conditions were used in biodegradation calculations for the site. BTEX biodegradation rates and their corresponding half-lives are summarized in Table 14.

9.3.2 TPH First-Order Rate Constant and Half-Life

A first-order rate constant is difficult to determine for TPH-G, TPH-D and TPH-O because each of these COCs is a suite of compounds. For calculations included in this summary report, the first order anaerobic biodegradation rate constant for TPH constituents is assumed to be 0.016/day, the same as benzene. The TPH anaerobic biodegradation rates and their corresponding half-lives are summarized in Table 14.

9.3.3 cPAH First-Order Rate Constants and Half-Lives

Literature values for cPAH anaerobic biodegradation rate constants in groundwater could not be found; therefore, values were estimated from Anaerobic, Sulfate-Dependent Degradation of Polycyclic Aromatic Hydrocarbons in Petroleum-Contaminated Harbor Sediment (Rothermich et al. 2002). Several of the conditions of the Rothermich et al. (2002) study are similar to the site and the sediments were anaerobic and sulfate-reducing; therefore, the data collected during the study was used to estimate first-order rate constants. This was done by plotting the concentration data versus time on a log plot with the log base-e. A best fit line was calculated and the slope of that line is the first-order rate constant for the anaerobic biodegradation reaction. Plots of the data used in the harbor sediment study are summarized in Appendix K.

The first-order anaerobic rate constants calculated for the cPAHs are approximately one order of magnitude lower than the aerobic rate constants for the same compounds (Syracuse Research Corporation 1999). This is consistent with a comparison of aerobic and anaerobic biodegradation rates for other petroleum hydrocarbons.

Anaerobic biodegradation rates or data could not be found for dibenzo(a,h)anthracene or indeno(1,2,3-cd)pyrene. The first-order rate constants for the compounds are assumed to 0.0004/day, or the same rate constant as that calculated for benzo(k)fluoranthene. cPAH biodegradation rates and their corresponding half-lives are summarized in Table 14.

9.4 COC Concentration at the Sea Wall

Using the COC-specific transport times summarized in Table 13, concentrations of COCs at the sea wall were calculated and are summarized in Table 15 by the first-order kinetics formula shown as Equation 10-4.

Equation 10-4

Where:

$C_{t,COC}$ = Concentration of COC at time t in $\mu\text{g/L}$

$C_{0,COC}$ = Initial concentration of COC in $\mu\text{g/L}$

e = Natural log, approximately 2.718

k = First-order anaerobic biodegradation rate constant in d^{-1}

t = Time elapsed in days

COC concentrations at the sea wall were predicted for each COC detected in wells in the Offsite Area. If a concentration was not detected in a well, a calculation was not completed. Predicted concentrations of TPH-G at the sea wall ranged from 0.36 to 20 $\mu\text{g/L}$, predicted benzene concentrations ranged from 0.25 to 1 $\mu\text{g/L}$ and the predicted toluene concentration at the sea wall was 0.0061 $\mu\text{g/L}$. The remaining COCs detected in Offsite Area monitoring wells include TPH-D, TPH-O, ethylbenzene, xylenes, benzo(a)anthracene, chrysene and benzo(b)fluoranthene. The predicted concentrations of these remaining COCs are less than 1 nanogram per liter. Concentrations of COCs at the sea wall are summarized in Table 15.

9.5 COC Discharge to Elliott Bay

Groundwater discharge to Elliott Bay (Q) was estimated to be approximately 2,510 gallons per day using Equation 10-5.

Equation 10-5

Where:

A = cross-sectional area of the groundwater discharge zone immediately downgradient of the site

i = Hydraulic gradient average

K = Hydraulic conductivity average

The cross-sectional zone of groundwater discharge to Elliott Bay is estimated to be approximately 76 meters long from the north end to the south end of the site and 3 meters deep. The resulting cross-sectional area of the discharge zone is approximately 229 square meters. An average site gradient of 0.017 ft/ft was used along with the geometric mean of K-values of the native fill material (12 feet/day) to complete the calculation for groundwater flux. The geometric mean of the K-value for the Offsite Area native fill is considered representative because this soil is impacted and groundwater must flow through the native fill formation on its natural gradient.

While COC concentrations vary in monitoring wells across the site, flux calculations were completed assuming a constant mass flux across the discharge zone. Using the predicted concentrations of COCs at the sea wall, the COC velocities and the cross-sectional area, discharge of COCs (mass flux) to Elliott Bay was predicted using Equation 10-6.

—

Equation 10-6

Where:

dM/dt = The discharge rate of COC mass per time

The predicted rates of COC discharge to Elliott Bay are summarized in Table 15. The maximum predicted TPH-G discharge rate to Elliott Bay is 0.032 pound per year (lb/year) or 22 milliliters per year (mL/yr). The maximum predicted discharge rate of benzene is 1.6×10^{-3} lbs/year or 0.84 mL/year and the remaining COCs each have maximum predicted discharge rates of less than 1×10^{-5} lbs/year and 0.01 mL/year.

9.6 Dissolved-Phase COC Fate and Transport Conclusions

Calculations summarized in preceding sections and in Table 15 show that remaining concentrations (highest measured value) measured in the offsite area, using conservative calculations, will not reach the sea wall at concentrations greater than site RALs or surface water criteria. While detectable concentrations of TPH-G and benzene potentially exist at the sea wall (assumed to be the point of groundwater discharge to Elliott Bay), concentrations of the remaining COCs are below current analytical method detection limits. Discharge calculations summarized above are considered to be conservative (overestimate concentrations) for the following reasons:

- It is unlikely that the full cross-sectional area contributes to COC discharge to Elliott Bay. Concentrations of COCs are heterogeneously distributed at the site.
- The soil organic carbon coefficient used in these calculations is likely lower compared to that at the site. Site fraction of organic carbon values are likely higher than 0.001 based on other published values (USEPA 1997). However, a value of 0.001 was used in accordance with section 173-340-747 and Equation 747-2 of MTCA.
- The distance and travel time between monitoring wells and the groundwater discharge point to Elliott Bay is likely greater than the distances used in the calculations. The sea wall was used for the calculation because it is the nearest site feature to Elliott Bay and a distance to the mean-tidal elevation is not available.
- The partitioning coefficients for TPH-G, TPH-D and TPH-O are likely higher than the values used for the calculation. Because sampling for various aliphatic and aromatic fractions of the TPH ranges has not been completed for the site, the lowest partitioning coefficient in the MTCA Table 747-4 for each TPH range was chosen. The actual partitioning coefficient for the TPH fractions at the site is likely one to two orders of magnitude greater. This would slow migration significantly and allow further biodegradation of COCs prior to discharge.

While the discharge calculations summarized in Table 15 are non-zero, the annual COC discharge to Elliott Bay is considered negligible. Elliott Bay is a feature of Puget Sound and Ecology estimates that the cPAH loading to Puget Sound from surface runoff and atmospheric deposition is approximately 90 lbs/year and calculates the TPH loading from surface runoff to be approximately 50,000,000 lbs/year (Ecology 2007b and 2010b). A second estimate revised the surface runoff TPH loading to be more than

100,000,000 lbs/year, respectively (Ecology 2008). These loading estimates are many orders of magnitude greater than the conservatively predicted COC discharge rate from site groundwater.

The predicted COC concentrations in groundwater at the sea wall are also below surface-water criteria for consumption of organisms, as summarized in Table 15. While TPH-G and benzene have detectable concentrations in site groundwater samples, neither exceeds current surface-water quality criteria. The surface-water criteria for TPH-G is "no visible sheen," while benzene is 51 µg/L. Visible sheen has never been reported and the predicted benzene concentration is 1 µg/L and more than one order of magnitude lower than the surface-water criteria. The remaining COCs detected at the site between May 2009 and April 2010 have predicted concentrations that are orders of magnitude below applicable surface-water quality criteria (USEPA 2010). Also, the lack of detectable COC concentrations in well MW-206 supports the predicted attenuation of dissolved-phase concentrations at the site. Well MW-206, located downgradient of well MW-204, has not had a detectable concentration of any COC since monitoring began, indicating that concentrations are attenuating between the two wells.

10. LNAPL Mobility Assessment

ARCADIS completed an LNAPL mobility study to assess the mobility of LNAPL observed in wells MW-30, MW-61A-R, RW-3 and RW-21. The assessment is based on the following information:

- historical site information
- site-specific petrophysical data determined from analysis of soil cores collected during installation of boring PZ-61A-R (located adjacent to well MW-61A-R)
- laboratory data for physical properties of LNAPL from well MW-61A-R
- database values for the physical properties of LNAPL observed in wells MW-30, RW-3 and RW-21

Collectively, this information was used to determine whether LNAPL present at the site is potentially mobile. The results of a LNAPL mobility assessment indicate that LNAPL near wells MW-30, RW-3 and RW-21 is immobile and not migrating. LNAPL near well MW-61A-R was found to be immobile based on laboratory residual saturation data, and mobile based on pore velocity potential, but cannot migrate further. A complete LNAPL mobility and migration assessment is included as Appendix L. Photographs of the soil cores used for site specific petrophysical data and soil core analytical results are included as Appendix M and N respectively. Appendix O contains the input parameters and results for the LNAPL pore velocity calculations.

11. Human Health and Ecological Risk Evaluation – Elliott Ave and Offsite Area

This section evaluates human health and ecological risk in the Elliott Avenue Area and the Offsite Area. This evaluation was prepared to facilitate risk-based management decisions for the site. The evaluation was conducted to present information that is used to develop a conceptual site model (CSM), evaluate potential risks to human health and the environment due to potential exposures to residual concentrations of petroleum hydrocarbon constituents in site media, and describe recommendations to support risk-based management decisions for the site.

11.1 Exposure Assessment

This section describes possible pathways associated with potential exposures to residual concentrations of petroleum hydrocarbon constituents detected in site media, and compares detected constituent concentrations with screening criteria, which define levels that Ecology has deemed to be safe for human exposure under various scenarios. These comparisons may be used to support risk-based decision making for the site.

11.2 Conceptual Site Model

The CSM or exposure evaluation flowchart for the Elliott Avenue and Offsite Areas is illustrated on Figure 16 and summarizes the relationships between potential COC sources, potentially complete transport pathways (shown by solid lines), exposure media, potential current and future receptors, and potentially complete and significant exposure pathways (shown by solid lines and filled circles) at the site. Details of the CSM are provided in Sections 11.2.1 through 11.2.5.

11.2.1 Potential Constituent Sources

As described in Section 2, Unocal operated a bulk fuel distribution facility from 1912 to approximately 1975 at the site. Leaded and unleaded gasoline, diesel, lube oil, motor oils and petroleum-based solvents (nonchlorinated) were stored onsite. During operation, historical releases to soil at the Elliott Avenue Area and Offsite Area may have occurred either directly from spills or leaks from associated piping, environmental transport via leaching from soil to groundwater, and/or dispersion in groundwater into adjacent areas. COCs that historically have been detected in soil and/or groundwater above laboratory reporting limits at least once during investigations of the Elliott

Avenue Area and the Offsite Area include: TPH-G, TPH-D, TPH-O, BTEX, cPAHs and dissolved lead.

11.2.2 Potential Transport Pathways and Receptors – Human Health

Typically risk assessments consider risks to potential onsite receptors, such as visitors to the OSP, that may be exposed to constituents in surface and subsurface soils by direct contact. In general, routes of exposure by direct contact include incidental ingestion of soil, dermal contact with soil and inhalation of constituents adhered to dust particles that have been released by wind erosion into ambient (outdoor) air. However, direct contact exposures to constituents in surface or subsurface soils are very unlikely because petroleum hydrocarbon-impacted soils are not exposed at the surface. Impacted soil near the location of well MW-61A-R in the Elliott Avenue Area is estimated to be found at approximately 13 feet bgs.

Elliott Avenue is a city-owned public ROW that is used for automobile traffic and pedestrian foot traffic. The street and sidewalk are entirely covered with asphalt pavement or concrete, the western side of Elliott Avenue is landscaped, and the eastern side of Elliott Avenue has a 16-foot, steep-sloped cement wall adjacent to the sidewalk. OSP visitors are not expected to be directly exposed to constituents in soil in the Elliott Avenue Area because access to this area is limited to the landscaped area on the west side of the street and to an aboveground pedestrian bridge, which is elevated approximately 16 feet over Elliott Avenue. The Elliott Avenue Area is expected to remain the same in the future because redevelopment is not currently planned for this area.

The Offsite Area comprises the active BNSF railroad tracks and a park waterfront area consisting of a walking trail, the Elliott Bay Trail (Terminal 91 Bike Path) and Pocket Beach. OSP visitors are not expected to be directly exposed to petroleum hydrocarbon constituents in soil at the BNSF railroad because access to this portion of the Offsite Area is limited to the pedestrian bridge above the BNSF railroad, which is elevated approximately 26 feet over the railroad tracks.

During the 2005 redevelopment of the waterfront portion of the Offsite Area, approximately 4,435 tons of soil were removed from the Offsite Area and the excavation was backfilled with imported or clean engineered soil, which was placed over an area that was excavated down to 16 feet bgs (GeoEngineers 2006a). In addition, impacted soil was first detected at approximately 15 feet bgs during the 2010 piezometer installation activities. Thus, potential direct-contact exposures to

constituents in surface and subsurface soils by park visitors are unlikely. The Offsite Area is expected to remain the same in the future because redevelopment is not currently planned for this area.

Although it is considered unlikely, the potential exists for future onsite maintenance personnel working on utility lines to be directly exposed to petroleum hydrocarbon constituents in soil. Exposure in the area of the “hot-spot” excavation is unlikely because clean engineered fill was used as backfill; however, in other portions of the Offsite and Elliott Avenue areas, maintenance workers are unlikely to work at depths near the groundwater smear zone where residual hydrocarbons may be present. In the Elliott Avenue Area, utilities are widespread; however, soil impacts appear to be confined to the smear zone and are deeper than where utilities are generally installed. In the Offsite Area, utilities are largely confined to the area along the railroad tracks. The remainder of the Offsite Area was recently redeveloped and additional utility installation activities in impacted zones are not expected. With the exception of the area along the railroad tracks, groundwater at the site was encountered at a depth greater than 9 feet bgs during the last sampling event. The typical depth of utility trenches typically does not exceed 8 feet bgs. Therefore, potential exposures are not expected to be significant.

An asphalt-paved street and concrete sidewalk are located north and south of the Elliott Avenue Area. The area north of the Offsite Area is landscaped, the area south of the Offsite Area comprises the Broad Street and Alaskan Way intersection, and located to the southwest is Pier 70 (office/retail use). Currently, the nearest potential offsite receptors to both the Elliott Avenue Area and the Offsite Area are commercial workers. These receptors may breathe dust particles if released from the site. However, as mentioned above, petroleum hydrocarbon-impacted soil is currently not exposed at the surface and this exposure pathway is not complete. Impacted soil is unlikely to be exposed at the surface in the future, because redevelopment of the site in the near future is not planned. Future offsite receptors, including commercial workers, are unlikely to be exposed to residual petroleum hydrocarbon constituents in site subsurface soils.

Constituents may leach from soil to groundwater beneath the site by percolation, resulting in potential direct contact exposures to constituents in groundwater. In general, routes of exposure by direct contact with groundwater include ingestion of tap water, dermal contact with tap water and inhalation of volatile constituents released from tap water. During recent redevelopment of the site into the OSP, the clean fill cap placed over portions of the site with residual petroleum hydrocarbon constituents in

subsurface soil was designed with relatively impermeable layers to limit leaching to groundwater from soil.

Moreover, groundwater at the site is not currently used as a potable drinking water source and is not expected to be used as a potable source in the future. Based on data presented in the Tidal Study Summary Report, Offsite Area (ARCADIS 2010c) groundwater consists of between 1 and 77 percent saltwater. Onsite park visitors and surrounding properties currently use, and in the future are expected to receive, drinking water from an offsite municipal public water supply. Therefore, pathways associated with potential direct exposures to constituents in groundwater beneath the site are not complete for current and future onsite and offsite receptors.

Another potential release mechanism at the site may include volatilization of constituents from groundwater to outdoor air and/or indoor air of current and future onsite or offsite buildings, or air within a trench used by future onsite maintenance/utility workers. Similarly, another potential release mechanism at the site may include volatilization of constituents in subsurface soil to outdoor air and/or indoor air of current and future onsite buildings, or air within a trench used by future onsite maintenance/utility workers.

Currently, buildings are not located on either the Elliott Avenue Area or the Offsite Area and construction of buildings on these areas in the future is unlikely. Therefore, pathways associated with potential indoor air exposures to residual volatile constituents in groundwater and subsurface soil onsite are not complete for current and potential future onsite receptors. COC vapors may migrate from groundwater into the indoor air of offsite buildings. However, impacted groundwater has been maintained onsite, as demonstrated by analytical data collected from compliance monitoring wells located along the north and south boundaries of the site, and the nearest offsite commercial buildings are located more than 100 feet from either area. Therefore, pathways associated with potential indoor air exposures to residual volatile constituents in groundwater are not complete for current and potential future offsite receptors.

The COCs identified for the site may volatilize from either subsurface soil or groundwater to outdoor air and may be inhaled by onsite or offsite potential receptors. However, this exposure pathway is considered to be insignificant given the atmospheric dilution effects from wind in the sites open air environment (e.g. no structures are present).

Therefore, inhalation of volatile constituents in outdoor air by potential onsite or offsite receptors is not considered to be a complete significant exposure pathway.

11.2.3 Potential Transport Pathways and Receptors – Ecological

The Elliott Avenue Area does not and is not likely to support ecological habitats because it consists of an asphalt-paved city-owned public ROW used for automobile and foot traffic. The landscaped area to the west of Elliott Avenue comprises grass planted during redevelopment of the site in 2006. Individual trees are planted in sidewalk cutouts on the east side of Elliott Avenue. The Elliott Avenue Area is located approximately 320 feet from Elliott Bay and surface-water runoff from this area drains to a storm drain with an outfall in Elliott Bay. The presence of clean engineered fill, paving and landscaping interrupts the pathway from residual petroleum in subsurface soil to surface-water runoff.

The Offsite Area is located adjacent to Elliott Bay, which is an ecological habitat. The dominant groundwater flow direction at the site is west toward Elliott Bay. Therefore, it is possible that groundwater from the site may migrate toward Elliott Bay, with subsequent exposures to aquatic organisms. However, the groundwater/surface-water transport mechanism and associated exposure pathways are insignificant based on the following:

- low detected COC concentrations in groundwater
- conservatively modeled concentrations in groundwater at locations closest to Elliott Bay are well below Ecology and USEPA surface water quality criteria
- low groundwater flux to Elliott Bay (Table 15)
- attenuation mechanisms prior to discharge

Groundwater RALs for the site, Offsite Area recent maximum groundwater concentrations and predicted concentrations at the sea wall are summarized in Table 16.

11.2.4 Comparison of Offsite Area Groundwater COC Concentrations with Site RALs

Although no potential exposure pathways are considered complete and significant (indicating that remaining COCs in soil and groundwater beneath the Offsite Area and

Elliott Avenue pose insignificant risk to human health and the environment), the site is required to meet conditions specified in the Order, which was most recently amended in 2007 (Ecology 1995). Concentrations of selected parameters (LNAPL, TPH, BTEX and dissolved lead) detected in the Elliott Avenue Area and Offsite Area groundwater must achieve the “applicable groundwater cleanup targets” specified in the Order. Historical groundwater monitoring data are summarized in Table 3; groundwater RALs for the site and Offsite Area maximum groundwater concentrations are summarized in Table 16.

As shown in Table 3, during the last 2 years of quarterly groundwater monitoring, benzene was not detected above the laboratory reporting limit in the Elliott Avenue Area compliance wells and toluene, ethylbenzene, total xylenes, TPH-G, TPH-D and TPH-O were detected at concentrations less than the site RALs. LNAPL or visible sheen were occasionally observed in wells MW-30 and were generally observed in MW-61A-R during the last two years of groundwater monitoring, exceeding the groundwater RAL for the site (e.g. presence of sheen or LNAPL).

During the last 2 years of groundwater monitoring in Offsite Area point of compliance wells (MW-200 to MW-203 and MW-205 to MW-207), dissolved-phase concentrations of BTEX, TPH-G, TPH-D and TPH-O were not detected above the groundwater RALs. Also, dissolved lead has not been detected at the site since November 2007 and monitoring wells in the Offsite Area have had either 12 or 13 consecutive monitoring events without a dissolved-lead concentration exceedance. The few concentrations that were detected remained more than two orders of magnitude below the site RAL.

Sheen was observed in wells MW-200, MW-201 and MW-205 during field activities conducted between August and September 2010 but with no corresponding elevated dissolved-phase concentration, which is consistent with previous observations of sheen and LNAPL at the site. Prior to this time frame, LNAPL was not observed in groundwater samples collected from the Offsite Area point of compliance wells, with the exception of MW-201 on May 14, 2008. The sheen observed in groundwater from MW-200 and MW-201 was noted on well development purge water. Also, LNAPL was observed on pump tubing from well MW-205 during hydraulic conductivity testing, but LNAPL has not accumulated in the well.

BTEX, TPH-D, TPH-O and dissolved lead concentrations in groundwater samples collected from MW-204 were below the groundwater RAL. However, during six monitoring events since well installation, TPH-G was detected above the laboratory reporting limit at concentrations ranging from 1.06 to 1.5 mg/L, which exceeds the

groundwater RAL of 1 mg/L. Method reporting limits remained below the site RALs. Analytical results and method reporting limits are summarized in Table 3.

Table 4 summarizes cPAH groundwater analytical data for the last 2 years (eight sampling events) for the Offsite Area. With the exception of cPAH concentrations detected in wells MW-206 and MW-207 on September 4, 2008, field-filtered concentrations of cPAHs were not detected above the laboratory reporting limit (the results from this event were suspect because the non-filtered cPAH concentrations were non-detectable, while filtered cPAH concentrations were detected). During monitoring of well MW-200 conducted on September 3, 2008, the laboratory detection limit for each of the cPAHs was elevated to 0.0476 µg/L, exceeding the RAL of 0.03 µg/L. However, the corresponding unfiltered sample from well MW-200 did not contain detectable concentrations, and the laboratory detection limit was 0.0476 µg/L for each constituent.

cPAH concentrations have not been detected in unfiltered groundwater samples from wells MW-200 and MW-203 through MW-207 since monitoring began in 2007. Detected cPAH concentrations in wells MW-201 and MW-202 have ranged up to 0.756 µg/L. Only benzo(a)anthracene, benzo(a)pyrene and chrysene have been detected above site RALs and the frequency of detection of exceedances in wells MW-201 and MW-202 has progressively decreased since monitoring began in 2007.

Except for sheen recently observed in wells MW-200, MW-201 and MW-205 and the TPH-G concentrations detected in MW-204, as of September 2010, groundwater at the site meets the RALs. The Offsite Area cPAH RALs were established to be protective of surface water, and site RALs for BTEX and lead are below the surface-water criteria summarized in Table 15. RALs for TPH-G, TPH-D and TPH-O are different in nature than the surface-water criteria (observation of sheen; USEPA 1986) for petroleum hydrocarbons. With the exception of the detected TPH-G concentration in well MW-204, detected analytical concentrations of these constituents have remained below site RALs since monitoring of wells MW-200 through MW-207 began in 2007.

Sheen observed in wells MW-200, MW-201, MW-205, RW-3 and RW-21 exceeds the groundwater RAL for the site. Sheen has not been observed in monitoring wells located immediately adjacent to Elliott Bay (MW-202, MW-206 and MW-207) and LNAPL accumulation has not been noted in wells where sheen has been observed.

Since wells MW-200 through MW-207 were initially sampled in 2007 (immediately after completion of site redevelopment), analytical data and field observations have not

indicated plume migration. While TPH-G concentrations in well MW-204 have generally been increasing slowly since monitoring began in 2007, TPH-G concentrations in adjacent and downgradient wells have generally remained below analytical method detection limits. The determination in Amendment 4 of the Order (Ecology 1995), stating that sediment remediation is not necessary, also indicates that the RALs were effective in limiting sediment and surface-water impacts. The continued trend of limited COC concentrations detected in groundwater at the site, coupled with the mass transport calculations presented above, indicate that the potential for sediment or surface-water impacts is insignificant. The maximum concentrations detected between May 2009 and September 2010, the current site RALs, and the predicted concentrations at the sea wall are summarized in Table 16.

In addition, monitoring wells MW-202, MW-206 and MW-207 are located next to Elliott Bay, along the area where site groundwater is likely discharging to surface water. Concentrations of cPAHs exceeding the current site RALs were detected in unfiltered groundwater samples collected from wells MW-201 and MW-202 on September 22, 2010; however, groundwater analytical results for field-filtered samples from these wells are below detection limits, groundwater RALs and surface-water quality criteria for all COCs. This lack of detectable concentrations of COCs, along with the predicted concentrations at the sea wall, indicate that site groundwater discharging to Elliott Bay is not likely to result in concentrations of COCs above surface-water standards.

11.2.5 Comparison of Soil Concentration Data with Soil Screening Criteria

Detected concentrations of TPH-G, TPH-D and TPH-O in soil collected during installation of piezometers in June 2010 were compared with MTCA Method A cleanup levels based on unrestricted land use (Ecology 2007c; Table 8). In the Elliott Avenue Area, the only TPH-G concentration detected above the laboratory reporting limit was from a depth of 19.5 feet bgs and exceeded the MTCA cleanup level. TPH-D was not detected above the laboratory reporting limits in the Elliott Avenue Area and reporting limits were below the MTCA cleanup level. TPH-O was either not detected above the laboratory reporting limits or the detected concentrations were below the MTCA cleanup level. Laboratory reporting limits were also below the MTCA cleanup level.

In the Offsite Area, TPH-D was detected above the laboratory reporting limit and also exceeded the MTCA cleanup level. It was detected at 19 and 25 feet bgs, which are depths that would be inaccessible to potential onsite receptors. TPH-G was detected above the MTCA cleanup level in samples collected at 15, 19, 25, 29.5 and 35 feet bgs. In the Offsite Area, TPH-O concentrations were either not detected above the

laboratory reporting limits or they did not exceed the MTCA cleanup levels. Laboratory reporting limits were also below the MTCA cleanup level.

11.3 Exposure Pathways Summary

Based on site conditions and COC concentrations in soil and groundwater present at the site, there are no complete current or future pathways for human or ecological exposures to COCs at the site. Groundwater transport of COCs to surface water is also insignificant given the concentrations in compliance wells, and the surface-water criteria.

12. Summary and Conclusions

Although there are areas of remaining impact to soil and groundwater in the Offsite Area and beneath Elliott Avenue, the data collected do not suggest the need for additional remedial measures. Remaining impacts do not present a risk to human health and the environment due to the absence of a complete or significant exposure pathway. For remaining dissolved phase impacts in groundwater, microbiological and geochemical parameter monitoring indicate that natural attenuation processes are occurring and that groundwater at the site likely has excess capacity for further attenuation of petroleum hydrocarbons. Aquifer testing data and conservative modeling indicate that remaining dissolved phase concentrations in groundwater will not reach Elliott Bay at concentrations exceeding either the site RALs or USEPA surface water quality criteria. Where LNAPL remains present, dissolved phase concentrations do not exceed RALs and petrophysical data indicate that the LNAPL at the site is largely immobile.

Hydraulic conductivity testing coupled with historical field data characterized groundwater transmissivity through the geologic formation. COC fate and transport was evaluated based on recent historical maximum concentrations detected in wells in the Offsite Area. COC concentrations at the sea wall were conservatively calculated and were at least one order of magnitude lower than the site RALs and the USEPA national recommended surface-water quality criteria.

The results of a LNAPL mobility assessment indicate that LNAPL near wells MW-30, RW-3 and RW-21 is immobile and by definition not migrating based on a comparison of the calculated LNAPL pore velocity for the LNAPL in each well to the ASTM criterion of 1×10^{-6} cm/sec. LNAPL near well MW-61A-R was found to be immobile based on laboratory residual saturation data, and mobile based on pore velocity potential, but does not have the potential to migrate beyond the footprint of the existing LNAPL plume.

Based on an evaluation of the possible current and expected future exposures to detected concentrations of residual petroleum hydrocarbon constituents in Elliott Avenue Area and Offsite Area soil and groundwater, no potentially complete and significant exposure pathways were identified. The Elliott Avenue Area does not and is not likely to support ecological habitats. The presence of clean engineered fill, paving and landscaping interrupts the pathway from residual petroleum in subsurface soil and groundwater to receptors. The Offsite Area is located immediately adjacent to Elliott Bay, which provides surface-water habitat. The LNAPL in wells MW-30, MW-61A-R,

Former Unocal Seattle
Marketing Terminal
3001 Elliott Avenue
Seattle, Washington

RW-3 and RW-21 is immobile and the predicted dissolved-phase COC concentrations in groundwater discharged to Elliott Bay are below site RALs and surface-water quality criteria. The limited dissolved-phase detected concentrations in the most downgradient monitoring wells support the predicted concentrations at the site. In addition, historical assessment of the sediments in Elliott Bay immediately adjacent to the site indicated that sediment remediation is not necessary (Ecology 1995). Given the apparent immobility of LNAPL in the Offsite Area, relatively low detected COC concentrations in groundwater (compared with surface-water criteria and RALs) and low COC flux to Puget Sound, this transport mechanism and associated potential exposure pathways are currently considered insignificant and are expected to remain insignificant.

13. Recommendations

Based on the data and analysis presented in this summary report, ARCADIS recommends the following:

- Continue quarterly gauging and semiannual groundwater monitoring of wells MW-30, MW-61A-R, RW-3 and RW-21.
- Continue semiannual groundwater monitoring of wells MW-200 through MW-207.
- Remove dissolved lead from the list of site COCs. Dissolved lead has not been detected at the site since November 2007 and monitoring wells in the Offsite Area have either 12 or 13 consecutive monitoring events without a dissolved-lead concentration exceedance. The few concentrations that were detected remained more than two orders of magnitude below the site RAL.
- Abandon piezometers PZ-61A-R, PZ-203 and PZ-204 in place.
- Abandon Trench D extraction wells RW-1, RW-2, RW-5 through RW-13 and RW-15 in place.
- The LNAPL occasionally observed in wells RW-3, RW-21 or MW-30 is not mobile. ARCADIS does not recommend further remedial operations on these wells unless quarterly gauging activities indicates a change in the volume or type of LNAPL present in the wells compared to historical observations.

ARCADIS recommends the following activities regarding the LNAPL sheen observed in well MW-205:

- Add monitoring of well MW-205 to the quarterly monitoring program.
- If LNAPL is observed and is recoverable, submit a sample for chemical testing and possible mobility parameter analysis.

14. References

ARCADIS U.S., Inc. 2010a. Revised Work Plan for LNAPL Mobility Assessment, Natural Attenuation Monitoring and Surfactant Application Pilot Testing. January 19, 2010.

ARCADIS U.S., Inc. 2010b. Addendum to the Revised Work Plan for LNAPL Mobility Assessment, Natural Attenuation Monitoring and Surfactant Application Pilot Testing. May 3, 2010.

ARCADIS U.S., Inc. 2010c. Tidal Study Summary Report. March 25, 2010.

ARCADIS U.S., Inc. 2010d. Progress Report No. 108, Second Semi-Annual 2010 Former Unocal Seattle Marketing Terminal 0724. In press.

ARCADIS U.S., Inc. 2010e. Mobile Multi-Phase Extraction Event Summary Report. February 23, 2010.

ASTM International. 2004. E 1943-98 (2010) – Standard Guide for Remediation of Ground Water by Natural Attenuation at Petroleum Release Sites (Reapproved 2004). DOI: 10.1520/E1943-98R10. ASTM International. West Conshohocken, Pennsylvania.

Carlisle, Dana. 2010. GeoEngineers, Inc.. Telephone conversation with Rebecca Andresen, ARCADIS U.S., Inc. May 2010.

GeoEngineers, Inc. 1996a. Summary of Historical Research Vicinity of Seattle Marketing Terminal. June 18, 1996.

GeoEngineers, Inc. 1996b. Draft Remedy Selection Report – Elliott Avenue. December 20, 1996.

GeoEngineers, Inc. 1997a. Supplemental Characterization – Elliott Avenue and Bay Street. January 6, 1997.

GeoEngineers, Inc. 1997b. Focused Feasibility Study, Offsite Area. June 9, 1997.

GeoEngineers, Inc. 1997c. Final Cleanup Report – Upper Yard. December 10, 1997.

GeoEngineers, Inc. 2006a. Cleanup Action Report – Offsite Area Soil Remedial Excavation. January 26, 2006.

GeoEngineers, Inc. 2006b. Progress Report No. 95 – Former Unocal Seattle Marketing Terminal 0724. October 26, 2006.

HartCrowser. 1999. Supplemental Focused Feasibility Study. HartCrowser. September 30, 1999.

Interstate Technology & Regulatory Council. 2009. Evaluating LNAPL Remedial Technologies for Achieving Project Goals. LNAPL-2. Washington, D.C.: Interstate Technology & Regulatory Council, LNAPLs Team. www.itrcweb.org.

Johnson, P.C., P. Lundegard, and Z. Liu. 2006. Source Zone Natural Attenuation at Petroleum Hydrocarbon Spill Sites: I. Site-Specific Assessment Approach,” *Groundwater Monitoring and Remediation* 26: 82-92.

Mercer, J.W., and R.M. Cohen. 1990. A Review of Immiscible Fluids in the Subsurface: Properties, Models, Characterization and Remediation. *Journal of Contaminant Hydrology* 6: 107-163.

Payne, F.C., J. Quinnan, and Scott Potter. 2008. Remediation Hydraulics. CRC Press. 2008.

Rothermich, M., L. Hayes, and D. Lovley. 2002. Anaerobic, Sulfate-Dependant Degradation of Polycyclic Aromatic Hydrocarbons in Petroleum-Contaminated Harbor Sediments. *Environmental Science and Technology* 36: 4811-4817.

Syracuse Research Corporation. 1997. Anaerobic Biodegradation of Organic Chemicals in Groundwater: A Summary of Field and Laboratory Studies. November 12, 1997.

Syracuse Research Corporation. 1999. Aerobic Biodegradation of Organic Chemicals in Environmental Media: A Summary of Field and Laboratory Studies. January 27, 1999.

Theis, C.V. 1935. The Relation Between the Lowering of the Piezometric Surface and the Rate and Duration of Discharge of a Well Using Groundwater Storage. *American Geophysical Union Transactions*. Vol. 16. pp. 519-524.

United States Environmental Protection Agency. 1986. Quality Criteria for Water 1986.

United States Environmental Protection Agency. 1997. VLEACH: A One-Dimensional Finite Difference Vadose Zone Leaching Model – Version 2.2. Developed by Dynamic Corporation for the United States Environmental Protection Agency, Office of Research and Development. Ada, Oklahoma.

United States Environmental Protection Agency. 2005. A Decision-Making Framework for Cleanup of Sites Impacted with Light Non-Aqueous Phase Liquids.

United States Environmental Protection Agency. 2010. National Recommended Water Quality Criteria.
<http://water.epa.gov/scitech/swguidance/waterquality/standards/current/index.cfm>. Last accessed September 28, 2010.

Washington State Department of Ecology. 1995. Amendment No. 4 to Order on Consent No. DE 88-N223. July 18, 1995

Washington State Department of Ecology 2007a. Amendment No. 5 to Order on Consent No. DE 88-N223. March 28, 2007.

Washington State Department of Ecology. 2007b. Control of Toxic Chemicals in Puget Sound – Phase 1: Initial Estimate of Loadings. October 2007.

Washington State Department of Ecology. 2007c. Model Toxics Control Act Statute and Regulation. Publication No. 94-06. Revised November 2007.

Washington State Department of Ecology. 2008. Control of Toxic Chemicals in Puget Sound – Phase 2: Improved Estimates of Loadings from Surface Runoff and Roadways. August 2008.

Washington State Department of Ecology. 2010a. E-mail Correspondence with Rebecca Andresen. ARCADIS U.S., Inc. May 2010.

Washington State Department of Ecology. 2010b. Control of Toxic Chemicals in Puget Sound, Phase 3: Study of Atmospheric Deposition of Air Toxics to the Surface of Puget Sound. July 2010.

ARCADIS

Tables

Table 1
Summary of Groundwater Analytical Data
Total Petroleum Hydrocarbons

Former Unocal Seattle Marketing Terminal
3001 Elliott Avenue
Seattle, Washington

Monitoring Well ¹	Date Sampled	LNAPL ²	BTEX (EPA Method 8020 or 8021B) (µg/L)				TPH (EPA Method 418.1) (mg/L)	NWTPH-Gx (mg/L)		NWTPH-D Extended ³ (mg/L)		Dissolved Lead (EPA 6000/7000 Series Method) (µg/L)
			B	T	E	X		Gasoline C ₇ - C ₁₂	Diesel C ₁₂ - C ₂₄	Heavy Oil >C ₂₄		
											1	
Upper Yard RALs		No visible sheen	40	14,300	1,400	4,400	--	1	10	15	50	
Upper Yard												
MW-37	06/01/90	--	<0.5	<0.5	<0.5	<0.5	<1	--	--	--	<5	
	10/16/90	--	<0.5	<0.5	<0.5	<0.5	<1	--	--	--	<5	
	01/17/91	--	<0.5	<0.5	<0.5	<0.5	--	<1	<1	--	<5	
	04/16/91	--	<0.5	<0.5	<0.5	<0.5	--	<1	<1	--	<2	
	09/15/95	ND	<0.50	<0.50	<0.50	<1.0	--	<1.0	<1.0	<0.75	--	
	12/14/95	ND	<0.50	<0.50	<0.50	<1.0	--	<0.05	<0.27	<0.75	--	
MW-38	06/01/90	--	<0.5	<0.5	<0.5	<0.5	<1	--	--	--	<5	
	10/16/90	--	<0.5	<0.5	<0.5	<0.5	<1	--	--	--	<5	
	01/17/91	--	<0.5	<0.5	<0.5	<0.5	--	<1	<1	--	<5	
	04/16/91	--	<0.5	<0.5	<0.5	<0.5	--	<1	<1	--	<2	
MW-39	01/17/91	--	<0.5	0.5	0.6	2.2	--	<1	<1	--	<5	
	04/16/91	--	<0.5	<0.5	<0.5	<0.5	--	<1	<1	--	--	
MW-40	06/01/90	--	<0.5	<0.5	<0.5	<0.5	<1	--	--	--	<5	
	10/16/90	--	<0.5	1.0	0.6	<0.5	<1	--	--	--	<5	
	01/17/91	--	<0.5	<0.5	<0.5	<0.5	--	<1	<1	--	<5	
	04/16/91	--	<0.5	<0.5	<0.5	<0.5	--	<1	<1	--	--	
MW-61A	03/13/98	ND	<0.500	<0.500	<0.500	<1.00	--	0.956	2.14	<0.750	--	
	06/18/98	ND	<2.50	<2.50	<2.50	<5.00	--	1.01	3.49	<0.750	--	
	09/03/98	ND	<0.500	<0.500	<0.500	<0.500	--	0.396	1.85	<0.750	<1.00	
	12/15/98	Sheen	<2.50	<2.50	2.82	12.8	--	10.2	146/73.0	<30.8/<15.8	--	
	Duplicate	12/15/98	Sheen	<2.50	<2.50	2.50	5.81	--	2.93	32.3/14.6	<3.75/<0.750	--
	Duplicate	03/23/99	Sheen	<0.500	<0.500	2.56	13.8	--	4.34	39.7/32.7	<8.25/<3.75	--
	Duplicate	03/23/99	Sheen	<2.50	<2.50	<2.50	<5.00	--	1.56	52.8/42.1	<8.25/<8.25	--
	Duplicate	07/01/99	ND	<0.500	<0.500	<0.900	<3.70	--	1.38 ⁴	4.43/2.08	<0.750/<0.750	<1.00
	Duplicate	07/01/99	ND	<1.00	<1.00	<1.40	<5.60	--	1.30 ⁴	4.45/3.08	<0.750/<0.750	--
	Duplicate	09/29/99	Sheen	<0.500	<5.00	<5.00	<1.00	--	2.16 ⁵	7.57/4.04	<0.750/<0.750	--
	Duplicate	09/29/99	Sheen	<0.500	<0.500	<5.00	<10.0	--	2.80 ⁵	19.7/21.1	0.758/<1.57	--
	Duplicate	12/16/99	Sheen	<0.500	<5.00	<3.50	<17.00	--	7.61	33.4/30.1	<15.8/<8.25	--
	Duplicate	01/04/00 ⁶	Sheen	<0.500	<5.00	<5.00	<4.15	--	1.40	12.1/8.29	<1.34/<1.34	--
	Duplicate	03/21/00	ND	<0.500	<0.500	<0.550	<1.85	--	0.831	13.1 ⁷	<0.750 ⁷	--
	Duplicate	03/21/00	ND	<0.500	<0.500	<0.720	<3.40	--	1.05	6.36 ⁷	<0.750 ⁷	--
	Duplicate	06/22/00 ⁸	ND	0.779	<0.500	<0.500	2.32	--	1.00	4.23/3.38	<0.750/<0.750	<1.00
Duplicate	06/22/00	ND	0.880	<0.500	0.591	2.46	--	0.836	5.99/4.13	<0.750/<0.750	--	
Duplicate	09/14/00	ND	<0.500	<0.500	<0.704	<3.11	--	1.36	2.49/1.50	<0.750/<0.750	--	
Duplicate	09/14/00	ND	<0.500	<0.500	0.986	<3.21	--	1.00	5.00/3.13	<0.750/<0.750	--	

Table 1
Summary of Groundwater Analytical Data
Total Petroleum Hydrocarbons

Former Unocal Seattle Marketing Terminal
3001 Elliott Avenue
Seattle, Washington

Monitoring Well ¹	Date Sampled	LNAPL ²	BTEX (EPA Method 8020 or 8021B) (µg/L)				TPH (EPA Method 418.1) (mg/L)	NWTPH-Gx (mg/L)	NWTPH-D Extended ³ (mg/L)		Dissolved Lead (EPA 6000/7000 Series Method) (µg/L)
			B	T	E	X		Gasoline	Diesel	Heavy Oil	
								C ₇ - C ₁₂	C ₁₂ - C ₂₄	>C ₂₄	
Upper Yard RALs		No visible sheen	40	14,300	1,400	4,400	--	1	10	15	50
Upper Yard (continued)											
MW-61A (continued)	12/21/00	ND	<0.500	<1.24	<0.500	<3.87	--	1.18	4.62/2.48	<0.750/<0.750	--
Duplicate	12/21/00 ⁹	ND	<0.500	<0.500	<0.500	<1.00	--	0.721	5.64/3.81	<0.750/<0.750	--
	03/14/01	ND	<0.565	<0.500	<1.38	<4.31	--	0.962	2.55/1.28	<0.750/<0.750	--
Duplicate	03/14/01	ND	<0.500	<0.500	<0.500	<1.12	--	0.498	1.82/0.668	<0.750/<0.750	--
	06/21/01	ND	<0.500	0.855	<0.500	1.14	--	0.773	2.45/1.55	<0.750/<0.750	<1.00
Duplicate	06/21/01	ND	<0.500	<0.500	<0.500	2.61	--	0.676	1.80/1.04	<0.750/<0.750	--
	09/25/01	Sheen	<0.500	<0.500	<0.500	2.62	--	0.839	14.3/11.3	<8.25/<0.750	--
Duplicate	09/25/01	Sheen	<0.500	0.923	0.592	4.22	--	0.918	5.12/4.47	<0.750/<0.750	--
	12/19/01	Sheen	0.825	<2.00	<1.00	<1.50	--	2.54	19.4/14.8 ¹⁰	<3.00/<3.00 ¹⁰	--
	03/26/02	Sheen	<0.500	<0.500	<0.500	1.24	--	0.414	1.38/0.615	<0.750/<0.750	--
Duplicate	03/26/02	Sheen	<0.500	<0.500	<0.500	1.85	--	0.592	1.99/0.847	<0.750/<0.750	--
Duplicate	06/19/03	Sheen	<0.500	<0.500	<0.500	<1.00	--	0.360	1.43	<0.750	--
	09/18/03	ND	<0.500	<0.500	<0.500	<1.00	--	<0.0500	0.728	<0.750	--
	12/03/03	Sheen	<0.500	<0.500	<0.500	1.22	--	0.604	2.46	<0.750	--
Duplicate	12/03/03	Sheen	<0.500	<0.500	<0.500	1.30	--	0.701	2.35	<0.750	--
MW-61A-R	03/02/06	Sheen/LNAPL	--	--	--	<1.00	--	--	--	--	--
	06/06/06	Sheen	<2.50	<2.50	7.64	7.48	--	3.92	20.6	<3.75	--
	09/15/06	Sheen	396	79.7	26.4	243	--	17.2	200	<142	--
	03/07/07	ND	<0.5	<0.5	0.5	<1.5	--	0.18	0.29	<0.095	--
	06/08/07	ND	<0.500	<2.0 ¹⁶	1.500	1.7	--	0.400	0.600	<0.095	<0.037
	09/26/07	ND	<0.5	<0.5	1.4	<1.5	--	0.430	0.770	0.120	--
	11/28/07	ND	<0.5	<0.5	0.9	<1.5	--	0.410	0.340	<0.100	--
Duplicate	11/28/07	ND	<0.5	<0.5	0.9	<1.5	--	0.400	0.670	0.370	--
	02/13/08	ND	<0.500	<0.500	0.980	1.14	--	0.455	0.308	<0.485	--
	05/14/08	ND	<0.500	<0.500	1.24	1.43	--	0.363	0.406	<0.472	--
	09/04/08	Sheen	<0.500	1.16	3.58	1.13	--	0.933	0.380	<0.490	--
	12/03/08	LNAPL	--	--	--	--	--	--	--	--	--
	02/18/09	Sheen	<0.500	<0.500	<0.500	1.32	--	0.490	0.830	<0.481	--
	09/10/09	LNAPL	--	--	--	--	--	--	--	--	--
	04/14/10	LNAPL	--	--	--	--	--	--	--	--	--
	09/23/10	ND	<0.50	<0.50	0.68	<2.0	--	0.76	1.5	<0.26	--

Table 1
Summary of Groundwater Analytical Data
Total Petroleum Hydrocarbons

Former Unocal Seattle Marketing Terminal
 3001 Elliott Avenue
 Seattle, Washington

Monitoring Well ¹	Date Sampled	LNAPL ²	BTEX (EPA Method 8020 or 8021B) (µg/L)				TPH (EPA Method 418.1) (mg/L)	NWTPH-Gx (mg/L)	NWTPH-D Extended ³ (mg/L)		Dissolved Lead (EPA 6000/7000 Series Method) (µg/L)
			B	T	E	X		Gasoline	Diesel	Heavy Oil	
								C ₇ - C ₁₂	C ₁₂ - C ₂₄	>C ₂₄	
Upper Yard RALs		No visible sheen	40	14,300	1,400	4,400	--	1	10	15	50
Upper Yard (continued)											
MW-62A	03/13/98	ND	<0.500	<0.500	<0.500	<1.00	--	0.288	<0.250	<0.750	--
	06/18/98	ND	<0.500	<0.500	<0.500	<1.00	--	<0.0500	<0.250	<0.750	--
	09/03/98	ND	<1.00	<0.500	0.901	2.79	--	0.134	<0.250	<0.750	<1.00
	12/14/98	ND	<0.500	<0.500	<0.500	<1.00	--	<0.0500	<0.250	<0.750	--
	03/23/99	ND	10.8	<5.00	<5.00	<10.0	--	<0.500	0.371/<0.250	<0.750/<0.750	--
	07/01/99	ND	<0.500	<0.500	<0.500	<1.00	--	<0.0500	0.311/<0.250	<0.750/<0.750	1.09
	09/29/99	ND	<0.500	<0.500	<0.500	<1.00	--	<0.0500	0.709/<0.250	<0.750/<0.750	--
	12/16/99	ND	<0.500	<0.500	<0.500	<1.00	--	<0.0500	<0.250	<0.750	--
	03/21/00	ND	<0.500	<0.500	<0.500	<1.00	--	<0.0500	<0.250	<0.750	--
	06/22/00	ND	<0.500	<0.500	<0.500	<1.00	--	<0.0500	<0.250	<0.750	<1.00
	09/14/00	ND	<0.500	<0.500	<0.500	<1.00	--	<0.0500	0.376/<0.250	<0.750/<0.750	--
	12/21/00 ⁹	ND	<0.500	<0.500	<0.500	<1.00	--	<0.0500	<0.250	<0.750	--
	03/14/01	ND	<0.500	<0.500	<0.500	<1.00	--	<0.0500	<0.250	<0.750	--
	06/21/01	ND	<0.500	<0.500	<0.500	<1.00	--	<0.0500	<0.250	<0.750	<1.00
	09/25/01	ND	<0.500	<0.500	<0.500	1.57	--	<0.0500	0.373/<0.250	<0.750/<0.250	--
	12/18/01	ND	<0.500	<2.00	<1.00	<1.50	--	<0.100	<0.250 ¹⁰	<0.750 ¹⁰	--
	03/26/02	ND	<0.500	<0.500	<0.500	<1.00	--	<0.0500	<0.250	<0.750	--
	06/19/02	ND	<0.500	<0.500	<0.500	<1.00	--	<0.0500	0.320/<0.250	<0.750/<0.750	<1.00
	12/13/02	ND	<0.500	<0.500	<0.500	<1.00	--	<0.0500	0.863	<0.750	--
	12/03/03	ND	<0.500	<0.500	<0.500	<1.00	--	<0.0500	<0.250	<0.750	--
Upper Yard RALs		No visible sheen	40	14,300	1,400	4,400	--	1	10	15	50
Upper Yard (continued)											
MW-63A	03/13/98	ND	<0.500	<0.500	<0.500	<1.00	--	<0.0500	<0.250	<0.750	--
	06/18/98	ND	<0.500	<0.500	<0.500	<1.00	--	<0.0500	<0.250	<0.750	--
	09/03/98	ND	<0.500	<0.500	<0.500	<1.00	--	<0.0500	<0.250	<0.750	<1.00
	12/14/98	ND	<0.500	<0.500	<0.500	<1.00	--	<0.0500	<0.250	<0.750	--
	03/23/99	ND	<0.500	<0.500	<0.500	<1.00	--	<0.0500	<0.250	<0.750	--
	07/01/99	ND	<0.500	<0.500	<0.500	<1.00	--	<0.0500	0.389/<0.250	<0.750/<0.750	1.82
	09/29/99	ND	<0.500	<0.500	<0.500	<1.00	--	<0.0500	0.305/<0.539	<0.750/<1.62	--
	12/16/99	ND	<0.500	<0.500	<0.500	<1.00	--	<0.0500	0.380/<0.250	<0.750/<0.750	--
	03/21/00	ND	<0.500	<0.500	<0.500	<1.00	--	<0.0500	<0.250	<0.750	--
	06/22/00	ND	<0.500	<0.500	<0.500	<1.00	--	<0.0500	0.366/<0.462	<0.750/<1.39	<1.00
	09/14/00	ND	<0.500	<0.500	<0.500	<1.00	--	<0.0500	0.273/<0.250	<0.750/<0.750	--
	12/21/00	ND	<0.500	<0.500	<0.500	<1.00	--	<0.0500	0.575/<0.250	<0.750/<0.750	--
	03/14/01	ND	<0.500	0.922	<0.500	1.92	--	<0.0500	<0.250	<0.750	--
	06/21/01	ND	<0.500	<0.500	<0.500	<1.00	--	<0.0500	<0.250	<0.750	<1.00
	09/25/01	ND	<0.500	<0.500	<0.500	<1.00	--	<0.0500	<0.250	<0.750	--
	12/18/01	ND	<0.500	<2.00	<1.00	<1.50	--	<0.100	0.468/<0.250 ¹⁰	<0.750/<0.750 ¹⁰	--
	03/26/02	ND	<0.500	<0.500	<0.500	<1.00	--	<0.0500	0.379/<0.250	<0.750/<0.750	--
	06/19/02	ND	<0.500	<0.500	<0.500	<1.00	--	<0.0500	0.299/<0.250	<0.750/<0.750	<1.00
	12/13/02	ND	<0.500	<0.500	<0.500	<1.00	--	<0.0500	0.514	<0.750	--
	12/03/03	ND	<0.500	<0.500	<0.500	<1.00	--	<0.0500	<0.250	<0.750	--

Table 1
Summary of Groundwater Analytical Data
Total Petroleum Hydrocarbons

Former Unocal Seattle Marketing Terminal
3001 Elliott Avenue
Seattle, Washington

Monitoring Well ¹	Date Sampled	LNAPL ²	BTEX (EPA Method 8020 or 8021B) (µg/L)				TPH (EPA Method 418.1) (mg/L)	NWTPH-Gx (mg/L)	NWTPH-D Extended ³ (mg/L)		Dissolved Lead (EPA 6000/7000 Series Method) (µg/L)
			B	T	E	X		Gasoline	Diesel	Heavy Oil	
								C ₇ - C ₁₂	C ₁₂ - C ₂₄	>C ₂₄	
MW-64	06/18/98	ND	<0.500	<0.500	<0.500	<1.00	--	<0.0500	<0.250	<0.750	--
	09/03/98	ND	<0.500	<0.500	<0.500	<1.00	--	<0.0500	<0.250	<0.750	<1.00
	12/14/98	ND	<0.500	<0.500	<0.500	<1.00	--	<0.0500	0.325/<0.250	<0.750/<0.750	--
	03/23/99	ND	<0.500	<0.500	<0.500	2.42	--	<0.0500	0.354/<0.250	<0.750/<0.750	--
	07/01/99	ND	<0.500	<0.500	<0.500	<1.00	--	<0.0500	0.319/<0.250	<0.750/<0.750	1.09
	09/29/99	ND	<0.500	<0.500	<0.500	<1.00	--	<0.0500	0.448/<0.564	<0.750/<0.169	--
	01/04/00 ⁶	ND	<0.500	<0.500	<0.500	<1.00	--	<0.0500	<0.250/<0.250	<0.750/<0.750	--
	03/21/00	ND	<0.500	<0.500	<0.500	<1.00	--	<0.0500	0.255 ⁷	<0.750	--
	06/22/00 ⁸	ND	<0.500	1.39	0.654	5.39	--	0.0908	0.315/<0.487	<0.750/<1.46	<1.00
	07/25/00	ND	<0.500	<0.500	<0.500	<1.00	--	<0.0500	<0.250	<0.750	<1.00
	09/14/00	ND	<0.500	<0.500	<0.500	<1.00	--	<0.0500	<0.250	<0.750	--
	12/21/00	ND	<0.500	<0.500	<0.500	<1.00	--	<0.0500	0.298/<0.250	<0.750/<0.750	--
	03/14/01	ND	<0.500	<0.500	<0.500	<1.00	--	<0.0500	<0.250	<0.750	--
	06/21/01	ND	<0.500	<0.500	<0.500	<1.00	--	<0.0500	<0.250	<0.750	<1.00
	09/25/01	ND	<0.500	<0.500	<0.500	<1.00	--	<0.0500	0.263/<0.250 ¹¹	<0.750/<0.750 ¹¹	--
	12/18/01	ND	<0.500	<2.00	<1.00	<1.50	--	<0.100	0.372/<0.250 ¹⁰	<0.750/<0.750 ¹⁰	--
	03/26/02	ND	<0.500	<0.500	<0.500	<1.00	--	<0.0500	<0.250	<0.750	--
	06/19/02	ND	<0.500	<0.500	<0.500	<1.00	--	<0.0500	0.499/<0.250	<0.750/<0.750	<1.00
12/13/02	ND	<0.500	<0.500	<0.500	<1.00	--	0.0563	0.38	<0.750	--	
12/03/03	ND	<0.500	<0.500	<0.500	<1.00	--	<0.0500	0.379	<0.750	--	

Table 1
Summary of Groundwater Analytical Data
Total Petroleum Hydrocarbons

Former Unocal Seattle Marketing Terminal
 3001 Elliott Avenue
 Seattle, Washington

Monitoring Well ¹	Date Sampled	LNAPL ²	BTEX (EPA Method 8020 or 8021B) (µg/L)				TPH (EPA Method 418.1) (mg/L)	NWTPH-Gx (mg/L)	NWTPH-D Extended ³ (mg/L)		Dissolved Lead (EPA 6000/7000 Series Method) (µg/L)
			B	T	E	X		Gasoline	Diesel	Heavy Oil	
								C ₇ - C ₁₂	C ₁₂ - C ₂₄	>C ₂₄	
Elliott Avenue RALs		No visible sheen	40	14,300	1,400	4,400	--	1	10	15	50
Elliott Avenue											
MW-30 ¹²	01/31/89	--	4.0	0.6	<0.5	<0.5	6	<5	--	--	--
	04/27/89	--	5.0	<0.5	0.6	<0.5	0.37	<5	--	--	--
	07/25/89	--	8.0	4.9	17.0	11.1	13	<5	--	--	--
	10/26/89	Product	--	--	--	--	--	--	--	--	--
	01/16/90	Product	--	--	--	--	--	--	--	--	--
	04/16/90	Product	--	--	--	--	--	--	--	--	--
	07/25/90	Product	--	--	--	--	--	--	--	--	--
	09/20/90	--	--	--	--	--	1	--	--	--	--
	10/16/90	--	<5.0	<5.0	<5.0	<5.0	10	--	--	--	28
	01/17/91	--	<0.5	<0.5	0.6	3.5	24	2	13	--	<5
	04/16/91	--	<0.5	<0.5	<0.5	<0.5	--	<1	<1	--	<2
	09/17/91	Product	--	--	--	--	--	--	--	--	--
	12/10/91	Product	--	--	--	--	--	--	--	--	--
	01/29/92	--	<0.5	<0.5	<0.5	<0.5	--	--	--	--	--
	03/13/98	ND	<0.500	<0.500	<0.500	<1.00	--	<0.0500	0.341	<0.750	--
Duplicate	03/13/98	ND	<0.500	<0.500	<0.500	<1.00	--	0.0522	<0.250	<0.750	--
	06/29/98	ND	<0.500	<0.500	<0.500	<1.00	--	<0.0500	<0.250	<0.750	<1.00
Duplicate	06/29/98	ND	<0.500	<0.500	<0.500	<1.00	--	<0.0500	<0.250	<0.750	--
	09/04/98	ND	<0.500	<0.500	<0.500	<1.00	--	<0.0500	0.575	<0.750	--
Duplicate	09/04/98	ND	<0.500	<0.500	<0.500	<1.00	--	<0.0500	0.416	<0.750	--
	12/15/98	ND	<0.500	<0.500	<0.500	<1.00	--	<0.0500	0.900/0.310	<0.750/<0.750	--
	03/24/99	Sheen	<0.500	<0.500	<0.500	<1.00	--	<0.0500	1.47/0.580	1.38/<0.750	--
	07/01/99	Sheen	<0.500	<0.500	<0.500	<1.00	--	<0.0500	0.526/<0.250	<0.750/<0.750	<1.00
	09/29/99	ND	<0.500	<0.500	<0.500	<1.00	--	<0.0500	1.12/<0.454	1.19/<1.36	--
	12/15/99	Sheen	<0.500	<0.500	<0.500	<1.00	--	0.0657	2.72/0.679	<1.43/<1.43	--
	03/22/00	ND	<0.500	<0.500	<0.500	<1.00	--	<0.0500	1.68/0.753	1.35/<0.750	--
	06/21/00	Sheen	<0.500	<0.500	<0.500	<1.00	--	0.0545	0.345/<0.250	<0.750/<0.750	<1.00
	09/14/00	--	--	--	--	--	--	--	--	--	--
	12/22/00	ND	<0.500	<0.500	<0.500	<1.00	--	0.0766	1.17/0.353	<0.750/<0.750	--
	03/15/01	ND	<0.500	<0.500	<0.500	<1.00	--	0.248	4.85/3.27	6.28/3.25	--
	06/22/01	Sheen	<0.500	<0.500	<0.500	<1.00	--	<0.0500	0.448/<0.250	<0.750/<0.750	--
	09/25/01	Sheen	<0.500	<0.500	<0.500	1.12	--	<0.0500	2.73/1.60	2.20/1.22	--
	12/18/01	Sheen	<0.500	<2.00	<1.00	<1.50	--	<0.100	1.09/<0.250 ¹⁰	<0.750/<0.750 ¹⁰	--
Duplicate	12/18/01	Sheen	<0.500	<2.00	<1.00	<1.50	--	0.107	1.05/<0.250 ¹⁰	<0.750/<0.750 ¹⁰	--
	03/27/02	Sheen	<0.500	<0.500	<0.500	<1.00	--	0.0793	1.62/0.536	0.936/<0.750	--
	06/20/02	Sheen	<0.500	<0.500	<0.500	<1.00	--	<0.0500	0.527/<0.250	<0.750/<0.750	--
	09/19/02	Sheen	<0.500	<0.500	<0.500	<1.00	--	<0.0500	<0.250	<0.750	--
	12/13/02	Sheen	<0.500	<0.500	<0.500	<1.00	--	<0.0500	0.419	<0.750	--
	06/19/03	Sheen	<0.500	<0.500	<0.500	<1.00	--	<0.0500	<0.250	<0.750	--
	09/18/03	ND	<0.500	<0.500	<0.500	<1.00	--	<0.0500	<0.250	<0.750	--
	12/03/03	Sheen	<0.500	<0.500	<0.500	<1.00	--	<0.0500	<0.250	<0.750	--

Table 1
Summary of Groundwater Analytical Data
Total Petroleum Hydrocarbons

Former Unocal Seattle Marketing Terminal
 3001 Elliott Avenue
 Seattle, Washington

Monitoring Well ¹	Date Sampled	LNAPL ²	BTEX (EPA Method 8020 or 8021B) (µg/L)				TPH (EPA Method 418.1) (mg/L)	NWTPH-Gx (mg/L)	NWTPH-D Extended ³ (mg/L)		Dissolved Lead (EPA 6000/7000 Series Method) (µg/L)
			B	T	E	X		Gasoline	Diesel	Heavy Oil	
								C ₇ - C ₁₂	C ₁₂ - C ₂₄	>C ₂₄	
Elliott Avenue RALs		No visible sheen	40	14,300	1,400	4,400	--	1	10	15	50
Elliott Avenue (continued)											
MW-30 ¹²	03/09/04	Sheen	<0.500	<0.500	<0.500	<1.00	--	<0.0500	<0.250	<0.750	--
(continued)	06/03/04	Sheen	<0.500	<0.500	<0.500	<1.00	--	<0.0500	0.544	<0.750	--
Duplicate	06/03/04	Sheen	<0.500	<0.500	<0.500	<1.00	--	<0.0500	0.913	0.765	--
	09/03/04	ND	<0.500	<0.500	<0.500	<1.00	--	<0.0500	0.451	<0.750	--
Duplicate	09/03/04	ND	<0.500	<0.500	<0.500	<1.00	--	<0.0500	1.33	0.765	--
	12/06/04	ND	<0.500	<0.500	<0.500	<1.00	--	<0.0500	0.381	<0.750	--
Duplicate	12/06/04	ND	<0.500	<0.500	<0.500	<1.00	--	<0.0500	0.268	<0.750	--
	03/04/05	ND	<0.500	<0.500	<0.500	<1.00	--	<0.0500	0.747	0.898	--
Duplicate	03/04/05	ND	<0.500	<0.500	<0.500	<1.00	--	<0.0500	0.835	0.976	--
	06/03/05	ND	<0.500	<0.500	<0.500	<1.00	--	<0.0500	0.278	<0.750	--
Duplicate	06/03/05	ND	<0.500	<0.500	<0.500	<1.00	--	<0.0500	<0.250	<0.750	--
	09/01/05	ND	<0.500	<0.500	<0.500	<1.00	--	<0.0500	0.416	<0.750	--
Duplicate	09/01/05	ND	<0.500	<0.500	<0.500	<1.00	--	<0.0500	0.366	<0.750	--
	12/01/05	ND	<0.500	<0.500	<0.500	<1.00	--	<0.0500	0.359	<0.708	--
Duplicate	12/01/05	ND	<0.500	<0.500	<0.500	<1.00	--	<0.0500	0.438	<0.714	--
	03/02/06	ND	<0.500	<0.500	<0.500	<1.00	--	<0.0500	<0.236	<0.708	--
Duplicate	03/02/06	ND	<0.500	<0.500	<0.500	<1.00	--	<0.0500	<0.236	<0.708	--
	06/06/06	ND	<0.500	<0.500	<0.500	<1.00	--	<0.0500	<0.250	<0.750	--
Duplicate	06/06/06	ND	<0.500	<0.500	<0.500	<1.00	--	<0.0500	<0.250	<0.750	--
	09/15/06	ND	<0.500	<0.500	<0.500	<1.00	--	<0.0500	<0.250	<0.708	--
Duplicate	09/15/06	ND	<0.500	<0.500	<0.500	<1.00	--	<0.0500	<0.250	<0.708	--
	03/07/07	Sheen	<0.5	<0.5	<0.5	<1.5	--	<0.048	1.6	0.53	--
	06/08/07	ND	<0.500	<0.500	<0.500	<1.50	--	<0.050	0.800	<0.095	<0.037
	09/26/07	ND	<0.5	<0.5	<0.5	<1.5	--	<0.050	0.300	<0.095	--
	11/28/07	ND	<0.5	<0.5	<0.5	<1.5	--	<0.050	0.340	0.120	--
	02/13/08	ND	<0.500	<0.500	<0.500	<1.00	--	<0.050	<0.278	<0.556	--
	05/14/08	ND	<0.500	<0.500	<0.500	<1.00	--	<0.050	<0.236	<0.472	--
	09/04/08	ND	<0.500	<0.500	<0.500	<1.00	--	<0.050	<0.243	<0.485	--
	12/05/08	ND	<0.500	<0.500	<0.500	<1.00	--	<0.050	<0.245	<0.490	--
	02/18/09	ND	<0.500	<0.500	<0.500	<1.00	--	<0.050	<0.248	<0.495	--
	05/12/09	LNAPL	--	--	--	--	--	--	--	--	--
	09/10/09	Sheen	<0.500	<0.500	<0.500	<1.00	--	<0.050	<0.250	<0.500	--
	04/14/10	Sheen	<0.50	<0.50	<0.50	<2.0	--	<0.050	<0.13	<0.27	--
	09/23/10	ND	<0.50	<0.50	<0.50	<2.0	--	<0.050	<0.13	<0.25	--
MW-31	08/10/89	--	<0.5	1.4	2.1	5.9	4.1	--	--	--	<5
	10/26/89	--	7.1	<0.5	1.0	3.3	5.5	--	--	--	<5
	01/16/90	--	4.2	<0.5	<0.5	<0.5	2.2	--	--	--	<5
	04/16/90	--	5.2	1.5	1.9	4.5	<1	--	--	--	<5
	07/25/90	--	2.0	<0.5	2.2	1.8	6	--	--	--	<5
	10/16/90	--	0.7	<0.5	<0.5	<0.5	<1	--	--	--	<5
	01/17/90	--	1.6	0.6	1.6	4.4	--	2	<1	--	<5
	04/16/91	--	1.8	0.6	1.9	4.5	--	<1	<1	--	<2
	09/17/91	--	--	--	--	--	--	--	--	--	--
	12/10/91	--	--	--	--	--	--	--	--	--	--
	09/14/95	ND	<0.50	<0.50	<0.50	<0.50	--	<0.05	0.54	0.94	--
	12/15/95	ND	<0.50	<0.50	<0.50	<1.0	--	<0.05	0.36	0.78	--
	03/14/96	ND	<0.50	<0.50	<0.50	<1.0	--	<0.05	1.2	0.94	--
	09/11/96	ND	<0.500	<0.500	<0.500	<1.00	--	0.0519	0.864	2.16	--
	03/18/97	ND	<0.500	<0.500	<0.500	<1.00	--	<0.050	0.546	<0.750	--

Table 1
Summary of Groundwater Analytical Data
Total Petroleum Hydrocarbons

Former Unocal Seattle Marketing Terminal
 3001 Elliott Avenue
 Seattle, Washington

Monitoring Well ¹	Date Sampled	LNAPL ²	BTEX (EPA Method 8020 or 8021B) (µg/L)				TPH (EPA Method 418.1) (mg/L)	NWTPH-Gx (mg/L)	NWTPH-D Extended ³ (mg/L)		Dissolved Lead (EPA 6000/7000 Series Method) (µg/L)
			B	T	E	X		Gasoline	Diesel	Heavy Oil	
								C ₇ - C ₁₂	C ₁₂ - C ₂₄	>C ₂₄	
Elliott Avenue RALs		No visible sheen	40	14,300	1,400	4,400	--	1	10	15	50
Elliott Avenue (continued)											
MW-31 (continued)	06/26/97	ND	<0.500	<0.500	<0.500	<1.00	--	<0.050	<0.250	<0.750	--
	06/29/98	ND	<0.500	<0.500	<0.500	<1.00	--	<0.0500	<0.250	<0.750	<1.00
	12/15/98	ND	<0.500	<0.500	<0.500	<1.00	--	<0.0500	0.320/<0.250	<0.750/<0.750	--
	07/01/99	ND	<0.500	<0.500	<0.500	<1.00	--	<0.0500	0.269/<0.250	<0.750/<0.750	<1.00
	12/16/99	ND	<0.500	<0.500	<0.500	<1.00	--	<0.0500	0.723/<0.250	<0.750/<0.750	--
	06/22/00 ⁸	ND	<0.500	5.05	1.39	15.0	--	0.167	<0.250	<0.750	<1.00
	12/22/00	ND	<0.500	<0.500	<0.500	<1.00	--	<0.0500	<0.250	<0.750	--
	06/22/01	ND	<0.500	<0.500	<0.500	<1.00	--	0.0576	<0.250	<0.750	<1.00
	12/18/01	ND	<0.500	<2.00	<1.00	<1.50	--	<0.100	1.08/<0.250 ¹⁰	<0.750/<0.750 ¹⁰	<1.00
	06/20/02	ND	<0.500	<0.500	<0.500	<1.00	--	<0.0500	0.568/<0.250	<0.750/<0.750	<1.00
	12/13/02	ND	<0.500	<0.500	<0.500	<1.00	--	<0.0500	0.436	1.27	--
	12/03/03	ND	<0.500	<0.500	<0.500	<1.00	--	<0.0500	<0.250	<0.750	--
MW-32	08/10/89	--	2.7	2.9	0.8	2.3	1.7	--	--	--	<5
	10/26/89	--	<0.5	1.7	<0.5	0.7	2.1	--	--	--	<5
	01/16/90	--	<0.5	<0.5	<0.5	<0.5	0.76	--	--	--	<5
	04/16/90	--	<0.5	1.0	<0.5	<0.5	<1	--	--	--	<5
	07/25/90	--	<0.5	<0.5	1.1	<0.5	1	--	--	--	<5
	10/16/90	--	<0.5	<0.5	<0.5	<0.5	<1	--	--	--	<5
	01/17/91	--	<0.5	<0.5	0.5	1.5	--	<1	<1	--	<5
	04/16/91	--	<0.5	0.6	0.6	1.6	--	<1	<1	--	<2
	09/17/91	--	--	--	--	--	--	--	--	--	--
	12/01/91	--	--	--	--	--	--	--	--	--	--
MW-58	09/15/95	ND	<0.50	<0.50	<0.50	<1.0	--	<1.0	<1.0	<0.75	--
	12/14/95	ND	<0.50	<0.50	<0.50	<1.0	--	<0.05	<0.25	<0.75	--
	03/14/96	ND	<0.50	<0.50	<0.50	<1.0	--	<0.05	<0.25	<0.75	--
	09/11/96	ND	<0.500	<0.500	<0.500	<1.00	--	<0.050	<0.250	0.979	--
	12/11/96	ND	--	--	--	--	--	--	--	--	--
	03/18/97	ND	<0.500	<0.500	<0.500	<1.00	--	<0.050	<0.372	<0.750	--
	06/25/97	ND	<0.500	<0.500	<0.500	<1.00	--	<0.0500	<0.250	<0.750	--
	06/30/98	ND	<0.500	<0.500	<0.500	<1.00	--	<0.0500	<0.250	<0.750	<1.00
	12/14/98	ND	<0.500	<0.500	<0.500	<1.00	--	<0.0500	<0.250	<0.750	--
	06/29/99	ND	<0.500	<0.500	<0.500	<1.00	--	<0.0500	<0.250	<0.750	--
	12/16/99	ND	<0.500	<0.500	<0.500	<1.00	--	<0.0500	<0.250	<0.750	--
	06/22/00	ND	<0.500	<0.500	<0.500	<1.00	--	<0.0500	<0.250	<0.750	--
	12/21/00	ND	<0.500	<0.500	<0.500	<1.00	--	<0.0500	<0.250	<0.750	--
	06/21/01	ND	<0.500	<0.500	<0.500	2.43	--	<0.0500	<0.250	<0.750	<1.00
	12/18/01	ND	<0.500	<2.00	<1.00	<1.50	--	<0.100	<0.250 ¹⁰	<0.750 ¹⁰	--
	06/19/02	ND	<0.500	<0.500	<0.500	<1.00	--	<0.0500	<0.250	<0.750	<1.00
	12/13/02	ND	<0.500	<0.500	<0.500	<1.00	--	<0.0500	<0.250	<0.750	--
	12/03/03	ND	<0.500	<0.500	<0.500	<1.00	--	<0.0500	<0.250	<0.750	--

Table 1
Summary of Groundwater Analytical Data
Total Petroleum Hydrocarbons

Former Unocal Seattle Marketing Terminal
3001 Elliott Avenue
Seattle, Washington

Monitoring Well ¹	Date Sampled	LNAPL ²	BTEX (EPA Method 8020 or 8021B) (µg/L)				TPH (EPA Method 418.1) (mg/L)	NWTPH-Gx (mg/L)	NWTPH-D Extended ³ (mg/L)		Dissolved Lead (EPA 6000/7000 Series Method) (µg/L)
			B	T	E	X		Gasoline	Diesel	Heavy Oil	
								C ₇ - C ₁₂	C ₁₂ - C ₂₄	>C ₂₄	
Elliott Avenue RALs		No visible sheen	40	14,300	1,400	4,400	--	1	10	15	50
Elliott Avenue (continued)											
MW-65	03/13/98	ND	<0.500	<0.500	<0.500	<1.00	--	<0.0500	<0.250	<0.750	--
	06/29/98	ND	<0.500	<0.500	<0.500	<1.00	--	<0.0500	<0.250	<0.750	<1.00
	09/04/98	ND	<0.500	<0.500	<0.500	<1.00	--	<0.0500	<0.250	<0.750	--
	12/15/98	ND	<0.500	<0.500	<0.500	<1.00	--	<0.0500	0.482/<0.250	<0.750/<0.750	--
	03/24/99	ND	<0.500	<0.500	<0.500	<1.00	--	<0.0500	0.975/<0.250	0.991/<0.750	--
	06/29/99	ND	<0.500	<0.500	<0.500	<1.00	--	<0.0500	0.750/<0.250	<0.750/<0.750	<1.00
	09/29/99	ND	<0.500	<0.500	<0.500	<1.00	--	<0.0500	0.683/<0.250	<0.750/<0.750	--
	12/16/99	ND	<0.500	<0.500	<0.500	<1.00	--	<0.0500	0.418/<0.250	<0.750/<0.750	--
	03/22/00	ND	<0.500	<0.500	<0.500	<1.00	--	<0.0500	0.816/<0.250	<0.750/<0.750	--
	06/23/00	ND	<0.500	<0.500	<0.500	<1.00	ND	<0.0500	0.689/<0.250	<0.750/<0.750	<1.00
	09/14/00	ND	<0.500	<0.500	<0.500	<1.00	--	<0.0500	0.603/<0.250	<0.750/<0.750	--
	12/22/00	ND	<0.500	<0.500	<0.500	<1.00	--	<0.0500	0.408/<0.250	<0.750/<0.750	--
	03/15/01	ND	<0.500	<0.500	<0.500	<1.00	--	<0.0500	0.620/<0.250	<0.750/<0.750	--
	06/22/01	ND	<0.500	<0.500	<0.500	<1.00	--	<0.0500	0.262/<0.250	<0.750/<0.750	<1.00
	09/25/01	ND	<0.500	<0.500	<0.500	<1.00	--	<0.0500	0.584/0.225	<0.750/<0.750	<1.00
	12/18/01	ND	<0.500	<2.00	<1.00	<1.50	--	<0.100	0.675/<0.250 ¹⁰	0.779/<0.750 ¹⁰	<1.00
	03/26/02	ND	<0.500	<0.500	<0.500	<1.00	--	<0.0500	0.749/<0.250	<0.750/<0.750	--
	06/20/02	ND	<0.500	<0.500	<0.500	<1.00	--	<0.0500	0.675/<0.250	<0.750/<0.750	<1.00
	12/13/02	ND	<0.500	<0.500	<0.500	<1.00	--	<0.0500	<0.250	<0.750	--
	12/03/03	ND	<0.500	<0.500	<0.500	<1.00	--	<0.0500	<0.250	<0.750	--
	03/07/07	ND	<0.500	<0.500	<0.500	<1.00	--	<0.048	0.730	0.170	--
	06/08/07	ND	<0.500	<0.500	<0.500	<1.50	--	<0.050	0.530	0.250	<0.037
	11/26/07	ND	<0.5	<0.5	0.7	<1.5	--	<0.050	0.470	0.190	--
MW-66	03/13/98	ND	<1.25	<1.25	<1.25	<5.00	--	1.20 ⁵	3.52	<0.750	--
	06/29/98	ND	<0.500	<0.500	<0.500	1.06	--	0.424	<0.250	<0.750	<1.00
	09/04/98	ND	<0.500	<0.500	<0.500	<2.00	--	0.257	1.27	<0.750	--
	12/15/98	ND	<0.500	<0.500	0.508	2.62	--	0.0387	0.906/<0.250	<0.750/<0.750	--
	03/24/99	ND	<0.500	<0.500	<0.900	<3.00	--	1.05	8.44/5.11	<0.750/<0.750	--
	07/01/99	Sheen	<0.500	<0.500	<0.500	<1.70	--	0.310 ⁴	1.37/0.596	<0.750/<0.750	<1.00
	09/29/99	ND	<0.500	<0.500	<0.500	<1.00	--	0.216 ⁴	2.32/1.10	<0.750/<0.750	--
	12/16/99	ND	<0.500	<0.500	<0.500	<1.00	--	0.332	0.659/<0.250	<0.750/<0.750	--
	03/22/00	ND	<0.500	<0.500	<0.500	<3.00	--	0.711	4.31/2.31	<0.750/<0.750	--
	06/23/00 ⁸	Trace	<0.500	<0.500	<0.500	<1.00	--	0.109	0.439/<0.250	<0.750/<0.750	<1.00
	09/14/00	ND	<0.500	<0.500	<0.500	<2.16	--	0.416	1.601/1.43	<0.750/<0.750	--
	12/22/00	ND	<0.500	<0.500	<0.500	<2.35	--	0.475	1.87/0.819	<0.750/<0.750	--
	03/15/01	ND	<0.570	<0.922	<0.500	<3.91	--	1.16	7.03/5.43	1.01/<0.750	--
	06/22/01	Sheen	<0.500	<0.500	<0.500	<1.00	--	0.130	0.409/<0.250	<0.750/<0.750	--
	09/25/01	Sheen	<0.500	<0.500	<0.500	1.06	--	0.142	4.06/3.14	0.811/<0.750	--
	12/18/01	Sheen	<0.500	<2.00	<1.00	<1.50	--	0.162	0.696/<0.250 ¹⁰	<0.750/<0.750 ¹⁰	--
	03/27/02	Sheen	<0.500	<0.500	<0.500	1.32	--	0.454	4.41/2.58	1.41/<0.750	--
	06/20/02	ND	<0.500	<0.500	<0.500	<1.00	--	0.052	0.650/<0.250	<0.750/<0.750	--
	09/19/02	Sheen	<0.500	<0.500	<0.500	<1.00	--	0.128	<0.250 ¹¹	<0.750 ¹¹	--
	12/13/02	Sheen	<0.500	<0.500	<0.500	<1.00	--	0.0845	0.688	<0.750	--

Table 1
Summary of Groundwater Analytical Data
Total Petroleum Hydrocarbons

Former Unocal Seattle Marketing Terminal
3001 Elliott Avenue
Seattle, Washington

Monitoring Well ¹	Date Sampled	LNAPL ²	BTEX (EPA Method 8020 or 8021B) (µg/L)				TPH (EPA Method 418.1) (mg/L)	NWTPH-Gx (mg/L)	NWTPH-D Extended ³ (mg/L)		Dissolved Lead (EPA 6000/7000 Series Method) (µg/L)
			B	T	E	X		Gasoline	Diesel	Heavy Oil	
								C ₇ - C ₁₂	C ₁₂ - C ₂₄	>C ₂₄	
Elliott Avenue RALs		No visible sheen	40	14,300	1,400	4,400	--	1	10	15	50
Elliott Avenue (continued)											
MW-66 (continued)	03/21/03	Sheen	<0.500	<0.500	<0.500	<1.00	--	0.114	2.72	<0.750	--
	06/19/03	Sheen	<0.500	<0.500	<0.500	<1.00	--	0.189 ⁵	0.707	<0.750	--
	09/18/03	Sheen	<0.500	<0.500	<0.500	<1.00	--	0.171	3.73	<0.750	--
	12/03/03	Sheen	<0.500	<0.500	<0.500	<1.00	--	0.0509	1.45	<0.750	--
	03/09/04	Sheen	<0.500	<0.500	<0.500	<1.00	--	0.131	0.446	<0.750	--
	06/03/04	ND	<0.500	<0.500	<0.500	<1.00	--	0.121	0.504	<0.750	--
	09/03/04	ND	<0.500	<0.500	<0.500	1.25	--	0.330	1.03	<0.750	--
	12/06/04	ND	<0.500	<0.500	<0.500	<1.00	--	0.116	0.380	<0.750	--
	03/04/05	ND	<0.500	<0.500	<0.500	1.4	--	0.275	0.577	<0.750	--
	06/03/05	ND	<0.500	<0.500	<0.500	<1.00	--	0.149	0.860	<0.750	--
	09/01/05	ND	<0.500	<0.500	<0.500	<1.00	--	0.119	0.678	<0.750	--
	12/01/05	ND	<0.500	<0.500	<0.500	<1.00	--	0.115	0.885	<0.721	--
	03/02/06	ND	<0.500	<0.500	<0.500	<1.00	--	0.0651	0.381	<0.714	--
	06/06/06	ND	<0.500	<0.500	<0.500	<1.00	--	0.128	<0.250	<0.750	--
	09/15/06	ND	<0.500	<0.500	<0.500	<1.00	--	0.0778	0.370	<0.708	--
	03/07/07	--	--	--	--	--	--	--	--	--	--
	Lower Yard RALs		No visible sheen	40	14,300	1,400	4,400	--	1	10	15
Lower Yard											
MW-81	10/06/98	Sheen	<0.700	<0.500	<0.500	<1.50	--	0.136 ⁴	27.6/14.8	26.5/10.0	--
	12/14/98	Sheen	<0.500	<0.500	<0.500	<1.00	--	0.273	3.62/0.563	1.18/<0.750	--
	03/23/99	Sheen	<0.500	0.646	<0.500	2.28	--	0.0632	3.90/2.17	3.14/1.50	--
	06/29/99	Sheen	<0.500	<0.500	<0.500	<1.60	--	0.418	5.22/3.12	4.62/2.55	<1.00
	09/29/99	ND	<0.500	<0.500	<0.500	<1.00	--	0.566 ⁴	1.69/0.390	<0.750/<0.750	--
	12/15/99	Sheen	<0.500	<0.500	<0.500	1.15	--	0.0762	2.46/0.366	0.764/<0.750	--
	03/21/00	ND	<0.500	<0.500	<0.500	<1.00	--	0.0817	2.20/0.800	1.28/<0.750	--
	06/22/00 ⁸	ND	0.536	3.35	2.37	16.2	--	0.234	2.36/0.495	1.29/<0.750	--
	09/14/00	ND	<0.500	<0.500	<0.500	<1.00	--	<0.0500	1.20/0.347	<0.750/<0.750	--
	12/21/00	ND	<0.500	<0.500	<0.500	<1.00	--	0.585	1.5/0.374	<0.750/<0.750	--
	03/15/01	ND	<0.500	<0.500	<0.500	<1.00	--	<0.0500	1.16/0.324	<0.750/<0.750	--
	06/21/01	ND	<0.500	<0.500	<0.500	<1.00	--	<0.0500	1.60/0.751	1.32/<0.750	--
	09/25/01	ND	<0.500	<0.500	<0.500	<1.00	--	<0.0500	1.59/1.11	0.832/<0.750	--
	12/18/01	ND	<0.500	<2.00	<1.00	<1.50	--	<0.100	1.62/0.323 ¹⁰	<0.750/<0.750 ¹⁰	--
	03/27/02	ND	<0.500	<0.500	<0.500	<1.00	--	0.0598	1.31/0.324	<0.750/<0.750	--
	06/19/02	ND	<0.500	<0.500	<0.500	<1.00	--	<0.0500	1.09/<0.250	<0.750/<0.750	--

Table 1
Summary of Groundwater Analytical Data
Total Petroleum Hydrocarbons

Former Unocal Seattle Marketing Terminal
3001 Elliott Avenue
Seattle, Washington

Monitoring Well ¹	Date Sampled	LNAPL ²	BTEX (EPA Method 8020 or 8021B) (µg/L)				TPH (EPA Method 418.1) (mg/L)	NWTPH-Gx (mg/L)	NWTPH-D Extended ³ (mg/L)		Dissolved Lead (EPA 6000/7000 Series Method) (µg/L)
			B	T	E	X		Gasoline	Diesel	Heavy Oil	
								C ₇ - C ₁₂	C ₁₂ - C ₂₄	>C ₂₄	
Lower Yard RALs		No visible sheen	40	14,300	1,400	4,400	--	1	10	15	50
Lower Yard (continued)											
MW-82	10/06/98	Sheen	<0.500	<0.500	<0.500	<3.50	--	0.311 ⁴	7.90/5.43	3.93/2.31	--
	12/14/98	ND	<0.500	<0.500	<0.500	<1.00	--	0.0793	0.787/<0.250	<0.750/<0.750	--
	03/23/99	Sheen	<0.500	<0.500	<0.500	<1.00	--	<0.0500	0.757/0.268	<0.750/<0.750	--
	06/29/99	ND	<0.500	<0.500	<0.500	<1.00	--	0.2750	3.92/2.51	2.19/1.29	1.25
	09/29/99	ND	<0.500	<0.500	<0.500	<1.00	--	0.0566	1.48/0.784	<0.750/<0.750	--
	12/15/99	ND	<0.500	<0.500	<0.500	<1.00	--	<0.0500	0.561/<0.250	<0.750/<0.750	--
	03/21/00	ND	<0.500	<0.500	<0.500	<1.00	--	<0.0500	0.797/0.349	<0.750/<0.750	--
	06/22/00 ⁵	ND	<0.500	1.72	1.48	13.6	--	0.2580	1.01/0.494	<0.750/<0.750	--
	09/14/00	ND	<0.500	<0.500	<0.500	<1.00	--	<0.0500	0.907/0.522	<0.750/<0.750	--
	12/21/00	ND	<0.500	<0.500	<0.500	<1.00	--	<0.0500	0.911/0.386	<0.750/<0.750	--
	03/15/01	ND	<0.500	<0.500	<0.500	<1.00	--	<0.0500	0.839/0.451	<0.750/<0.750	--
	06/21/01	ND	<0.500	<0.500	<0.500	<1.00	--	<0.0500	1.03/0.675	0.830/<0.750	--
	09/25/01	ND	<0.500	<0.500	<0.500	1.14	--	<0.0500	0.742/0.288	<0.750/<0.750	--
	12/18/01	ND	<0.500	<2.00	<1.00	<1.50	--	<0.100	0.278/<0.250 ¹⁰	<0.750/<0.750 ¹⁰	--
	03/27/02	ND	<0.500	<0.500	<0.500	<1.00	--	<0.0500	0.517/<0.250	<0.750/<0.750	--
	06/19/02	ND	<0.500	<0.500	<0.500	<1.00	--	<0.0500	0.513/<0.250	<0.750/<0.750	--
	MW-83	10/06/98	ND	<0.500	<0.500	<0.500	<1.00	--	0.0923 ⁴	2.19/1.31	2.36/1.11
12/14/98		ND	<0.500	<0.500	<0.500	<1.00	--	<0.0500	0.634/<0.250	<0.750/<0.750	--
03/23/99		ND	<0.500	<0.500	<0.500	<1.00	--	<0.0500	0.413/<0.250	<0.750/<0.750	--
06/29/99		ND	<0.500	<0.500	<0.500	<1.00	--	<0.0500	0.729/0.417	0.957/<0.750	<1.00
09/29/99		ND	<0.500	<0.500	<0.500	<1.00	--	<0.0500	0.390/<0.250 ¹³	<0.750/<0.750 ¹³	--
12/15/99		ND	<0.500	<0.500	<0.500	1.07	--	<0.0500	0.271/<0.250	<0.750/<0.750	--
03/21/00		ND	<0.500	<0.500	<0.500	<1.00	--	<0.0500	<0.250	<0.750	--
06/22/00 ⁵		ND	<0.500	<0.500	<0.500	3.76	--	0.205	0.302/<0.250	<0.750/<0.750	--
09/14/00		ND	<0.500	<0.500	<0.500	<1.00	--	<0.0500	<0.250	<0.750	--
12/21/00		ND	<0.500	<0.500	<0.500	<1.00	--	<0.0500	0.316/<0.250	<0.750/<0.750	--
03/15/01		ND	<0.500	<0.500	<0.500	<1.00	--	<0.0500	<0.250	<0.750	--
06/21/01		ND	<0.500	<0.500	<0.500	<1.00	--	<0.0500	0.268/<0.250	<0.750/<0.750	--
09/25/01		ND	<0.500	<0.500	<0.500	<1.00	--	<0.0500	<0.250	<0.750	--
12/18/01		ND	<0.500	<2.00	<1.00	<1.50	--	<0.100	<0.250 ¹⁰	<0.750 ¹⁰	--
03/27/02		ND	<0.500	<0.500	<0.500	<1.00	--	<0.0500	<0.250	<0.750	--
06/19/02		ND	<0.500	<0.500	<0.500	<1.00	--	<0.0500	0.299/<0.250	<0.750/<0.750	--
MW-84		10/06/98	ND	<2.00	<1.00	<1.50	<8.00	--	1.09 ⁴	3.52/1.70	1.03/<0.750
	12/14/98	ND	<0.500	<0.500	<0.500	2.33	--	0.241	1.01/0.351	<0.750/<0.750	--
	03/23/99	ND	<0.500	<0.500	<0.500	<1.00	--	<0.0500	Note 14	Note 14	--
	04/01/99	ND	--	--	--	--	--	--	0.0259	<0.750	--
	06/29/99	ND	<0.500	<0.500	<0.500	<1.00	--	0.0833	2.17/1.12	1.61/<0.750	<1.00
	09/29/99	ND	<0.500	<0.500	<0.500	<1.00	--	0.0517	0.941/0.338	<0.750/<0.750	--
	12/15/99	ND	<0.500	<0.500	<0.500	<1.00	--	<0.0500	0.692/<0.250	<0.750/<0.750	--
	03/21/00	ND	<0.500	<0.500	<0.500	<1.00	--	<0.0500	0.859/<0.750	<0.750/<0.750	--
	06/22/00	ND	<0.500	<0.500	<0.500	1.37	--	0.0551	1.39/0.649	0.808/<0.750	--

Table 1
Summary of Groundwater Analytical Data
Total Petroleum Hydrocarbons

Former Unocal Seattle Marketing Terminal
3001 Elliott Avenue
Seattle, Washington

Monitoring Well ¹	Date Sampled	LNAPL ²	BTEX (EPA Method 8020 or 8021B) (µg/L)				TPH (EPA Method 418.1) (mg/L)	NWTPH-Gx (mg/L)	NWTPH-D Extended ³ (mg/L)		Dissolved Lead (EPA 6000/7000 Series Method) (µg/L)
			B	T	E	X		Gasoline	Diesel	Heavy Oil	
								C ₇ - C ₁₂	C ₁₂ - C ₂₄	>C ₂₄	
Lower Yard RALs		No visible sheen	40	14,300	1,400	4,400	--	1	10	15	50
Lower Yard (continued)											
MW-84 (continued)	09/14/00	ND	<0.500	<0.500	<0.500	<1.00	--	<0.0500	0.485/<0.250	<0.750/<0.750	--
	12/21/00	ND	<0.500	<0.500	<0.500	<1.00	--	<0.0500	1.09/0.419	<0.750/<0.750	--
	03/15/01	ND	0.584	<0.500	<0.500	<1.00	--	<0.0500	0.559/<0.250	<0.750/<0.750	--
	06/21/01	ND	<0.500	<0.500	<0.500	<1.00	--	<0.0500	0.407/<0.250	<0.750/<0.750	--
	09/25/01	ND	<0.500	<0.500	<0.500	<1.00	--	<0.0500	0.324/<0.250	<0.750/<0.750	--
	12/18/01	ND	<0.500	<2.00	<1.00	<1.50	--	<0.100	0.965/<0.250 ¹⁰	0.926/<0.750 ¹⁰	--
	03/27/02	ND	<0.500	<0.500	<0.500	<1.00	--	<0.0500	0.883/<0.250	<0.750/<0.750	--
	06/19/02	ND	<0.500	<0.500	<0.500	<1.00	--	<0.0500	0.792/<0.250	<0.750/<0.750	--
MW-85	10/06/98	ND	<0.500	<0.500	<0.500	<1.00	--	<0.0500	0.434/<0.250	<0.750/<0.750	--
	12/14/98	ND	<0.500	<0.500	<0.500	<1.00	--	<0.0500	0.451/<0.250	<0.750/<0.750	--
	03/23/99	ND	<0.500	<0.500	<0.500	<1.00	--	<0.0500	0.404/<0.250	<0.750/<0.750	--
	06/29/99	ND	<0.500	<0.500	<0.500	<1.00	--	<0.0500	0.412/<0.250	<0.750/<0.750	<1.00
	09/29/99	ND	<0.500	<0.500	<0.500	<1.00	--	<0.0500	0.365/<0.250	<0.750/<0.750	--
	12/16/99	ND	<0.500	0.628	<0.500	<1.00	--	<0.0500	0.350/<0.250	<0.750/<0.750	--
	03/21/00	ND	<0.500	<0.500	<0.500	<1.00	--	<0.0500	0.350/<0.250	<0.750/<0.750	--
	06/22/00	ND	<0.500	<0.500	<0.500	<1.00	--	<0.0500	0.376/<0.250	<0.750/<0.750	--
	09/14/00	ND	<0.500	<0.500	<0.500	<1.00	--	<0.0500	<0.250	<0.750	--
	12/21/00	ND	<0.500	<0.500	<0.500	<1.00	--	<0.0500	0.360/<0.250	<0.750/<0.750	--
	03/15/01	ND	<0.500	<0.500	<0.500	<1.00	--	<0.0500	<0.250	<0.750	--
	06/21/01	ND	<0.500	<0.500	<0.500	1.57	--	<0.0500	<0.250	<0.750	--
	09/25/01	ND	<0.500	<0.500	<0.500	1.57	--	<0.0500	<0.250	<0.750	--
	12/19/01	ND	<0.500	<2.00	<1.00	<1.50	--	<0.100	0.600/<0.250 ¹⁰	<0.750/<0.750 ¹⁰	--
	03/27/02	ND	<0.500	<0.500	<0.500	<1.00	--	<0.0500	0.271/<0.250	<0.750/<0.750	--
06/20/02	ND	<0.500	<0.500	<0.500	<1.00	--	<0.0500	0.702/<0.250	<0.750/<0.750	--	
MW-86	10/06/98	Sheen	<0.800	<0.500	<0.500	<1.00	--	<0.0500	2.28/2.99	2.57/2.92	--
	12/15/98	ND	<0.500	<0.500	<0.500	<1.00	--	<0.0500	1.65/<0.250	<0.750/<0.750	--
	03/23/99	Sheen	<0.500	<0.500	<0.500	2.54	--	<0.0500	1.39/<0.250	0.883/<0.750	--
	07/01/99	ND	<0.500	<0.500	<0.500	<1.00	--	<0.0500	0.926/<0.250	<0.750/<0.750	<1.00
	09/29/99	ND	<0.500	<0.500	<0.500	<1.00	--	<0.0500	0.481/<0.250	<0.750/<0.750	--
	12/16/99	ND	<0.500	0.574	<0.500	<1.00	--	<0.0500	1.71/<0.250	<0.750/<0.750	--
	03/21/00	ND	<0.500	<0.500	<0.500	<1.00	--	<0.0500	0.901 ⁷	<0.750 ⁷	--
	06/22/00	ND	<0.500	<0.500	<0.500	<1.00	--	<0.0500	0.535/<0.250	<0.750/<0.750	--
	09/14/00	ND	<0.500	<0.500	<0.500	<1.00	--	<0.0500	0.617/<0.250	<0.750/<0.750	--
	12/21/00 ⁹	ND	<0.500	<0.500	<0.500	<1.00	--	<0.0500	0.374/<0.250	<0.750/<0.750	--
	03/15/01	ND	<0.500	<0.500	<0.500	<1.00	--	<0.0500	0.436/0.250	<0.750/<0.750	--
	06/21/01	ND	<0.500	<0.500	<0.500	<1.00	--	<0.0500	0.606/0.310	<0.750/<0.750	--
	09/25/01	ND	<0.500	<0.500	<0.500	<1.00	--	<0.0500	<0.250	<0.750	--
	12/19/01	ND	<0.500	<2.00	<1.00	<1.50	--	<0.100	1.21/<0.250 ¹⁰	<0.750/<0.750 ¹⁰	--
	03/27/02	ND	<0.500	<0.500	<0.500	<1.00	--	<0.0500	0.464/<0.250	<0.750/<0.750	--
	06/20/02	ND	<0.500	<0.500	<0.500	<1.00	--	<0.0500	0.629/<0.250	<0.750/<0.750	--

Table 1
Summary of Groundwater Analytical Data
Total Petroleum Hydrocarbons

Former Unocal Seattle Marketing Terminal
 3001 Elliott Avenue
 Seattle, Washington

Monitoring Well ¹	Date Sampled	LNAPL ²	BTEX (EPA Method 8020 or 8021B) (µg/L)				TPH (EPA Method 418.1) (mg/L)	NWTPH-Gx (mg/L)	NWTPH-D Extended ³ (mg/L)		Dissolved Lead (EPA 6000/7000 Series Method) (µg/L)
			B	T	E	X		Gasoline	Diesel	Heavy Oil	
								C ₇ - C ₁₂	C ₁₂ - C ₂₄	>C ₂₄	
Offsite Area RALs		No visible sheen	40	14,300	1,400	4,400	--	1	10	15	50
Offsite Area											
MW-8	01/31/89	--	0.6	<0.5	<0.5	<0.5	0.21	--	--	--	<25
	04/27/89	--	<0.5	<0.5	<0.5	<0.5	1.1	--	--	--	<5
	07/25/89	--	4.3	2.1	<0.5	<0.5	0.17	--	--	--	18
	10/26/89	--	<0.5	<0.5	<0.5	<0.5	0.94	--	--	--	<5
	01/16/90	--	<0.5	<0.5	<0.5	<0.5	0.35	--	--	--	<5
	04/16/90	--	2.8	<0.5	<0.5	<0.5	<1	--	--	--	<50
	07/25/90	--	<0.5	<0.5	<0.5	<0.5	<1	--	--	--	<50
	10/16/90	--	<0.5	<0.5	<0.5	<0.5	2	--	--	--	<100
	01/17/91	--	<0.5	<0.5	<0.5	<0.5	<1	<1	<1	--	<5
	04/16/91	--	<0.5	<0.5	<0.5	<0.5	--	<1	<1	--	<20
	09/17/91	--	<0.5	<0.5	<0.5	<0.5	--	<1	<1	--	6
	12/10/91	--	<0.5	<0.5	<0.5	<0.5	--	<1	<1	--	<3.0
	06/25/98	ND	<0.500	<0.500	<0.500	<1.00	--	<0.0500	<0.250	<0.750	<1.00
	12/14/98	ND	<0.500	<0.500	<0.500	<1.00	--	<0.0500	0.523/<0.250	<0.750/<0.750	--
	07/01/99	ND	<0.500	<0.500	<0.500	<1.00	--	<0.0500	<0.250	<0.750	--
	12/16/99	ND	<0.500	<0.500	<0.500	<1.00	--	<0.0500	0.501/<0.403	<1.21/<1.21	--
	06/22/00	ND	<0.500	<0.500	<0.500	<1.00	--	0.0558	0.273/<0.249	<0.750/<0.737	--
	12/21/00	ND	<0.500	<0.500	<0.500	<1.00	--	<0.0500	0.441/<0.245	<0.750/<0.750	--
	06/21/01	ND	<0.500	<0.500	<0.500	<1.00	--	<0.0500	<0.250	<0.750	--
	12/19/01	ND	<0.500	<2.00	<1.00	<1.50	--	<0.100	0.464/<0.250 ¹⁰	<0.750/<0.750 ¹⁰	--
06/19/02	ND	<0.500	<0.500	<0.500	<1.00	--	<0.0500	0.271/<0.250	<0.750/<0.750	--	
12/13/02	ND	<0.500	<0.500	<0.500	<1.00	--	<0.0500	0.439	0.762	--	
12/02/03	ND	<0.500	<0.500	<0.500	<1.00	--	<0.0500	<0.250	<0.750	--	
MW-10	01/31/89	--	<0.5	<0.5	<0.5	<0.5	0.36	--	--	--	<5
	04/27/89	--	<0.5	<0.5	<0.5	<0.5	2.2	--	--	--	<5
	07/25/89	--	<0.5	<0.5	<0.5	<0.5	0.45	--	--	--	<5
	10/26/89	--	<0.5	<0.5	<0.5	<0.5	3.4	--	--	--	<5
	01/16/90	--	<0.5	<0.5	<0.5	<0.5	0.35	--	--	--	<5
	04/16/90	--	<0.5	<0.5	<0.5	<0.5	<1	--	--	--	<5
	07/25/90	--	<0.5	<0.5	<0.5	<0.5	6	--	--	--	<5
	10/16/90	--	<0.5	<0.5	<0.5	<0.5	<1	--	--	--	<5
	01/17/91	--	<0.5	<0.5	<0.5	<0.5	--	<1	<1	--	<5
	04/16/91	--	<0.5	<0.5	<0.5	<0.5	--	<1	<1	--	<5
	09/17/91	--	<0.5	<0.5	<0.5	<0.5	--	<1	<1	--	<2
	12/10/91	--	<0.5	<0.5	<0.5	<0.5	--	<1	<1	--	<3
	06/25/98	ND	<0.500	<0.500	<0.500	<1.00	--	0.0593	<0.250	<0.750	1.24
	12/14/98	ND	<0.500	<0.500	<0.500	1.28	--	0.0715	0.953/<0.250	<0.750/<0.750	--
	07/01/99	ND	<0.500	<0.500	<0.500	<1.00	--	<0.0500	0.652/<0.250	<0.750/<0.750	--
	12/16/99	ND	<0.500	<0.500	<0.500	<1.00	--	0.076	0.706/<0.475	<1.43/<1.43	--
	06/22/00	ND	<0.500	<0.500	<0.500	<1.00	--	0.0846	<0.503 ¹³	<1.51 ¹³	--
	12/21/00	ND	<0.500	<0.500	<0.500	1.10	--	0.0657	0.555/<0.250	<0.750/<0.750	--
	06/21/01	ND	<0.500	<0.500	<0.500	<1.00	--	<0.0500	0.301/<0.250	<0.750/<0.750	--
	12/19/01	ND	<0.500	<2.00	<1.00	<1.50	--	<0.100	0.551/<0.250 ¹⁰	<0.750/<0.750 ¹⁰	--
06/19/02	ND	<0.500	<0.500	<0.500	1.43	--	0.0545	0.656/<0.250	<0.750/<0.750	--	
12/13/02	ND	<0.500	<0.500	<0.500	<1.00	--	<0.0500	<0.250	<0.750	--	
12/02/03	ND	<0.500	<0.500	<0.500	<1.00	--	<0.0500	<0.250	<0.750	--	

Table 1
Summary of Groundwater Analytical Data
Total Petroleum Hydrocarbons

Former Unocal Seattle Marketing Terminal
3001 Elliott Avenue
Seattle, Washington

Monitoring Well ¹	Date Sampled	LNAPL ²	BTEX (EPA Method 8020 or 8021B) (µg/L)				TPH (EPA Method 418.1) (mg/L)	NWTPH-Gx (mg/L)	NWTPH-D Extended ³ (mg/L)		Dissolved Lead (EPA 6000/7000 Series Method) (µg/L)
			B	T	E	X		Gasoline	Diesel	Heavy Oil	
								C ₇ - C ₁₂	C ₁₂ - C ₂₄	>C ₂₄	
Offsite Area RALs		No visible sheen	40	14,300	1,400	4,400	--	1	10	15	50
Offsite Area (continued)											
MW-20	01/31/89	--	<0.5	<0.5	<0.5	<0.5	1.1	--	--	--	<5
	04/27/89	--	<0.5	<0.5	<0.5	<0.5	1.6	--	--	--	<5
	07/25/89	--	1.0	<0.5	<0.5	<0.5	0.31	--	--	--	<5
	10/26/89	--	0.7	<0.5	<0.5	<0.5	3.2	--	--	--	<5
	01/16/90	--	<0.5	<0.5	<0.5	<0.5	1.4	--	--	--	<5
	04/16/90	--	0.6	<0.5	<0.5	<0.5	<1	--	--	--	<5
	07/25/90	--	<0.5	<0.5	<0.5	<0.5	<1	--	--	--	<5
	10/16/90	--	<0.5	<0.5	<0.5	<0.5	<1	--	--	--	<5
	01/17/91	--	<0.5	<0.5	<0.5	<0.5	--	<1	<1	--	<5
	04/16/91	--	<0.5	<0.5	<0.5	<0.5	--	<1	<1	--	<2
	09/17/91	--	<0.5	<0.5	<0.5	<0.5	--	<1	<1	--	<2
	12/10/91	--	<0.5	<0.5	<0.5	<0.5	--	<1	<1	--	3.4
	06/25/98	ND	<0.500	<0.500	<0.500	<1.00	--	<0.0500	<0.250	<0.750	<1.00
	12/15/98	ND	<0.500	<0.500	<0.500	<1.00	--	<0.0500	0.287/<0.250	<0.750/<0.750	--
	07/01/99	ND	<0.500	<0.500	<0.500	<1.00	--	<0.0500	0.291/<0.250	<0.750/<0.750	--
	12/16/99	ND	<0.500	<0.500	<0.500	<1.00	--	<0.0500	0.452/<0.250	<0.750/<0.750	--
	06/22/00	ND	<0.500	<0.500	<0.500	1.67	--	<0.0500	<0.250	<0.750	--
	12/21/00	ND	<0.500	<0.500	<0.500	<1.00	--	<0.0500	0.569/<0.250	<0.750/<0.750	--
	06/21/01	ND	<0.500	<0.500	<0.500	<1.00	--	<0.0500	0.277/<0.250	<0.750/<0.750	--
	12/19/01	ND	<0.500	<2.00	<1.00	<1.50	--	<0.100	1.05/<0.250 ¹⁰	<0.750/<0.750 ¹⁰	--
06/20/02	ND	6.60	<0.500	<0.500	3.30	--	<0.0500	0.627/<0.250	<0.750/<0.750	--	
12/13/02	ND	<0.500	<0.500	<0.500	<1.00	--	<0.0500	<0.250	<0.750	--	
12/02/03	ND	<0.500	<0.500	<0.500	<1.00	--	<0.0500	<0.250	<0.750	--	
MW-25	01/31/89	--	<0.5	4.7	<0.5	2.3	3.7	--	--	--	<5
	04/27/89	--	7.2	1.2	1.6	<0.5	0.93	--	--	--	<5
	07/25/89	--	1.4	0.8	<0.5	<0.5	1.2	--	--	--	<5
	10/26/89	--	<0.5	<0.5	<0.5	<0.5	7.8	--	--	--	<5
	01/16/90	--	1.3	<0.5	<0.5	<0.5	4.9	--	--	--	<5
	04/16/90	--	6.6	1.4	0.8	2.7	<1	--	--	--	<5
	07/25/90	--	2.5	0.6	0.6	0.8	<1	--	--	--	<5
	10/16/90	--	<0.5	<0.5	<0.5	0.8	<1	--	--	--	<5
	01/17/91	--	1.0	0.7	<0.5	1.4	<1	<1	<1	--	<5
	04/16/91	--	0.9	<0.5	<0.5	<0.5	--	<1	<1	--	<20
	09/19/91	--	<0.5	<0.5	<0.5	0.6	--	<1	<1	--	<20
	12/10/91	--	<0.5	<0.5	<0.5	<0.5	--	<1	<1	--	<3.0
	03/13/98	ND	<0.500	<0.500	<0.500	<1.00	--	0.160	<0.250	<0.750	--
	06/24/98	ND	<0.500	1.68	<0.500	<1.00	--	0.689	<0.250	<0.750	<1.00
	09/03/98	ND	<0.500	<0.500	<0.500	<1.00	--	0.0716	<0.250	<0.750	--
	12/14/98	ND	<0.500	<0.500	0.795	1.31	--	0.0697	1.26/<0.250	<0.750/<0.750	--
	03/24/99	ND	<0.600	<0.700	<1.00	<2.50	--	0.118	0.969/<0.250	<0.750/<0.750	--
	07/01/99	ND	<0.500	<0.500	<0.500	<1.00	--	<0.0500	0.719/<0.250	<0.750/<0.750	<20.0
	09/29/99	ND	<0.500	3.52	<0.500	<10.0	--	0.136	1.58/<0.476	<1.43/<1.43	--
	12/16/99	ND	<0.500	<0.500	0.632	1.81	--	0.166	1.31/<0.250	<0.750/<0.750	--
03/22/00	ND	<0.500	1.94	<0.500	<1.00	--	0.148	1.36/<0.447	<1.34/<1.34	--	
06/22/00	ND	<0.500	<0.500	<0.500	<1.00	--	0.0876	0.674/<0.250	<0.750/<0.750	<10.0	
09/15/00	ND	<0.500	<0.607	<0.500	<1.28	--	0.716	1.26/<0.250	<0.750/<0.750	--	

Table 1
Summary of Groundwater Analytical Data
Total Petroleum Hydrocarbons

Former Unocal Seattle Marketing Terminal
3001 Elliott Avenue
Seattle, Washington

Monitoring Well ¹	Date Sampled	LNAPL ²	BTEX (EPA Method 8020 or 8021B) (µg/L)				TPH (EPA Method 418.1) (mg/L)	NWTPH-Gx (mg/L)	NWTPH-D Extended ³ (mg/L)		Dissolved Lead (EPA 6000/7000 Series Method) (µg/L)
			B	T	E	X		Gasoline	Diesel	Heavy Oil	
								C ₇ - C ₁₂	C ₁₂ - C ₂₄	>C ₂₄	
Offsite Area RALs		No visible sheen	40	14,300	1,400	4,400	--	1	10	15	50
Offsite Area (continued)											
MW-25 (continued)	12/21/00	ND	<0.500	<0.500	<0.500	1.18	--	0.0991	1.25/<0.250	<0.750/<0.750	--
	03/15/01	ND	<0.500	<0.500	<0.500	1.75	--	0.0664	1.19/<0.250	<0.750/<0.750	--
	06/21/01	ND	<0.500	<0.500	<0.500	<1.00	--	<0.0500	0.538/<0.250	<0.750/<0.750	<1.00
	09/25/01	ND	<0.500	<0.500	<0.500	<1.00	--	0.0596	0.864/<0.250	<0.750/<0.750	--
	12/19/01	ND	<0.500	<2.00	<1.00	<1.50	--	0.175	2.22/<0.250 ¹⁰	0.852/<0.750 ¹⁰	--
	03/26/02	ND	<0.500	<0.500	<0.500	1.39	--	0.12	0.861/<0.250	<0.750/<0.750	--
	06/19/02	ND	<0.500	<0.500	<0.500	1.44	--	0.108	0.706/<0.250	<0.750/<0.750	<1.00
	12/13/02	ND	<0.500	<0.500	<0.500	<1.00	--	0.0578	<0.250	<0.750	--
	12/02/03	ND	<0.500	<0.500	<0.500	<1.00	--	0.110	<0.250	<0.750	--
MW-26	01/31/89	--	<0.5	<0.5	<0.5	<0.5	0.64	--	--	--	25
	04/27/89	--	<0.5	<0.5	<0.5	<0.5	0.08	--	--	--	<5
	07/25/89	--	<0.5	<0.5	<0.5	<0.5	1.4	--	--	--	<5
	10/26/89	--	<0.5	<0.5	<0.5	<0.5	0.94	--	--	--	<5
	01/16/90	--	<0.5	<0.5	<0.5	<0.5	1.8	--	--	--	<5
	04/16/90	--	<0.5	<0.5	<0.5	<0.5	<1	--	--	--	<5
	07/25/90	--	<0.5	<0.5	<0.5	<0.5	2	--	--	--	<5
	10/16/90	--	<0.5	<0.5	<0.5	<0.5	<1	--	--	--	<50
	01/17/91	--	<0.5	<0.5	<0.5	<0.5	<1	<1	<1	--	<50
	04/16/91	--	<0.5	<0.5	<0.5	<0.5	--	<1	<1	--	<2
	09/19/91	--	<0.5	<0.5	<0.5	<0.5	--	<1	<1	--	<2
	12/10/91	--	<0.5	<0.5	<0.5	<0.5	--	<1	<1	--	<3.0
	06/30/98	ND	<0.500	<0.500	<0.500	<1.00	--	<0.0500	<0.250	<0.750	--
	12/15/98	ND	<0.500	<0.500	<0.500	<1.00	--	<0.0500	<0.250	<0.750	--
	07/01/99	ND	<0.500	<0.500	<0.500	<1.00	--	<0.0500	<0.250	<0.750	--
	12/16/99	ND	<0.500	<0.500	<0.500	<1.00	--	<0.0500	<0.250/<0.250	<0.750/<0.750	--
	06/22/00	ND	<0.500	<0.500	<0.500	<1.00	--	<0.0500	<0.250	<0.750	--
	12/22/00	ND	<0.500	<0.500	<0.500	<1.00	--	<0.0500	<0.250	<0.750	--
	06/21/01	ND	<0.500	<0.500	<0.500	<1.00	--	<0.0500	<0.250	<0.750	--
	12/19/01	ND	<0.500	<2.00	<1.00	<1.50	--	<0.100	0.445/<0.250 ¹⁰	<0.750/<0.750 ¹⁰	--
06/20/02	ND	<0.500	<0.500	<0.500	<1.00	--	<0.0500	<0.250	<0.750	--	
12/13/02	ND	<0.500	<0.500	<0.500	<1.00	--	<0.0500	<0.250	<0.750	--	
12/02/03	ND	<0.500	<0.500	<0.500	<1.00	--	<0.0500	<0.250	<0.750	--	
MW-27	01/31/89	--	<0.5	1.8	<0.5	<0.5	0.64	--	--	--	<5
	04/27/89	--	<0.5	<0.5	<0.5	<0.5	0.23	--	--	--	<5
	07/25/89	--	1.0	<0.5	<0.5	<0.5	0.68	--	--	--	<5
	10/26/89	--	1.3	0.7	<0.5	0.7	1.1	--	--	--	<5
	01/16/90	--	<0.5	<0.5	<0.5	<0.5	1.3	--	--	--	<5
	04/16/90	--	<0.5	<0.5	<0.5	0.6	<1	--	--	--	<5
	07/25/90	--	<0.5	<0.5	<0.5	<0.5	2	--	--	--	<5
	10/16/90	--	<0.5	<0.5	<0.5	<0.5	<1	--	--	--	<5
	01/17/91	--	0.6	<0.5	<0.5	<0.5	--	<1	<1	--	<5
	04/16/91	--	<0.5	<0.5	<0.5	0.9	--	<1	<1	--	<2
	09/19/91	--	<0.5	<0.5	<0.5	1.1	--	<1	<1	--	4

Table 1
Summary of Groundwater Analytical Data
Total Petroleum Hydrocarbons

Former Unocal Seattle Marketing Terminal
3001 Elliott Avenue
Seattle, Washington

Monitoring Well ¹	Date Sampled	LNAPL ²	BTEX (EPA Method 8020 or 8021B) (µg/L)				TPH (EPA Method 418.1) (mg/L)	NWTPH-Gx (mg/L)	NWTPH-D Extended ³ (mg/L)		Dissolved Lead (EPA 6000/7000 Series Method) (µg/L)
			B	T	E	X		Gasoline	Diesel	Heavy Oil	
								C ₇ - C ₁₂	C ₁₂ - C ₂₄	>C ₂₄	
Offsite Area RALs		No visible sheen	40	14,300	1,400	4,400	--	1	10	15	50
Offsite Area (continued)											
MW-27 (continued)	12/10/91	--	<0.5	<0.5	<0.5	<0.5	--	<1	<1	--	<3.0
	03/13/98	ND	<0.500	<0.500	<0.500	<1.00	--	<0.0500	<0.250	<0.750	--
	06/24/98	ND	<0.500	2.85	<0.500	<1.00	--	0.188	<0.250	<0.750	<1.00
	09/03/98	ND	<0.800	<0.500	<0.500	<1.00	--	0.0961	0.316	<0.750	--
	12/14/98	ND	<4.00	<0.500	<0.500	1.33	--	0.119	0.485/<0.250	<0.750/<0.750	--
	03/24/99	ND	<0.500	<0.500	<0.500	<1.00	--	<0.0500	0.394/<0.250	<0.750/<0.750	--
	07/01/99	ND	<0.500	<2.20	<0.500	<1.00	--	0.0823	0.394/<0.250	<0.750/<0.750	--
	09/29/99	ND	<0.500	1.87	<0.500	<1.00	--	<0.0500	0.830/<0.323	<0.750/<0.750	--
	12/16/99	ND	<0.500	<0.500	<0.500	1.29	--	0.0925	0.544 ¹⁵	<0.750 ¹⁵	--
	03/22/00	ND	<0.500	0.874	<0.500	<1.00	--	<0.0500	0.468/<0.250	<0.750/<0.750	--
	06/22/00	ND	0.692	<0.500	<0.500	<1.00	--	<0.0500	<0.250	<0.750	--
	09/15/00	ND	<0.605	<0.500	<0.500	<1.00	--	<0.0500	0.420/<0.250	<0.750/<0.750	--
	12/21/00	ND	1.89	<0.500	<0.500	<1.00	--	0.0727	0.308/<0.250	<0.750/<0.750	--
	03/15/01	ND	<0.500	<0.500	<0.500	<1.00	--	<0.0500	0.537/<0.250	<0.750/<0.750	--
	06/21/01	Sheen	<0.500	<0.500	<0.500	<1.00	--	<0.0500	0.259/<0.250	<0.750/<0.750	--
	09/25/01	ND	0.571	<0.500	<0.500	<1.00	--	<0.0500	1.38/0.547	<0.750/<0.750	--
	12/19/01	Sheen	<0.500	<2.00	<1.00	<1.50	--	<0.100	<0.250 ¹⁰	<0.750 ¹⁰	--
	03/26/02	ND	<0.500	<0.500	<0.500	<1.00	--	<0.0500	0.257/<0.250	<0.750/<0.750	--
	06/19/02	ND	<0.500	<0.500	<0.500	1.05	--	<0.0500	<0.250	<0.750	--
	09/19/02	ND	<0.500	<0.500	<0.500	<1.00	--	<0.0500	<0.250	<0.750	--
	12/13/02	ND	<0.500	<0.500	<0.500	<1.00	--	<0.0500	<0.250	<0.750	--
	03/21/03	ND	<0.500	<0.500	<0.500	<1.00	--	<0.0500	<0.250	<0.750	--
	06/19/03	ND	<0.500	<0.500	<0.500	<1.00	--	<0.0500	<0.250	<0.750	--
	09/18/03	ND	<0.500	<0.500	<0.500	<1.00	--	<0.0500	0.672	<0.750	--
	12/03/03	ND	<0.500	<0.500	<0.500	<1.00	--	<0.0500	<0.250	<0.750	--
	03/09/04	ND	<0.500	<0.500	<0.500	<1.00	--	<0.0500	<0.250	<0.750	--
	06/03/04	ND	<0.500	<0.500	<0.500	<1.00	--	<0.0500	<0.250	<0.750	--
	09/03/04	ND	<0.500	<0.500	<0.500	<1.00	--	<0.0500	<0.250	<0.750	--
	12/06/04	ND	<0.500	<0.500	<0.500	<1.00	--	<0.0500	<0.250	<0.750	--
	03/04/05	ND	<0.500	<0.500	<0.500	<1.00	--	<0.0500	<0.250	<0.750	--
	06/03/05	ND	<0.500	<0.500	<0.500	<1.00	--	<0.0500	<0.250	<0.750	--
	09/01/05	ND	<0.500	<0.500	<0.500	<1.00	--	<0.0500	<0.250	<0.750	--
	12/01/05	ND	<0.500	<0.500	<0.500	<1.00	--	<0.0500	<0.236	<0.708	--
	03/02/06	ND	<0.500	<0.500	<0.500	<1.00	--	<0.0500	<0.236	<0.708	--
MW-27R	03/07/07	ND	<0.5	<0.5	<0.5	<1.5	--	<0.048	<0.076	<0.094	--
	09/26/07	ND	<0.5	<0.5	<0.5	<1.5	--	<0.050	<0.077	<0.096	<0.47
	11/27/07	ND	<0.5	<0.5	<0.5	<1.5	--	<0.050	<0.080	<0.100	0.091
MW-34	10/26/89	--	1.7	3	<0.5	2.1	0.27	--	--	--	<5
	01/16/90	--	<0.5	<0.5	<0.5	<0.5	0.08	--	--	--	<5
	04/16/90	--	<0.5	<0.5	<0.5	<0.5	<1	--	--	--	<5
	07/25/90	--	<0.5	<0.5	<0.5	<0.5	<1	--	--	--	<5
	10/16/90	--	<0.5	<0.5	<0.5	<0.5	<1	--	--	--	<5
	01/17/91	--	<0.5	<0.5	<0.5	<0.5	--	<1	<1	--	<5
	04/16/91	--	<0.5	<0.5	<0.5	<0.5	--	<1	<1	--	<2
	09/17/91	--	<0.5	<0.5	<0.5	<0.5	--	<1	<1	--	3
	12/01/91	--	<0.5	<0.5	<0.5	<0.5	--	<1	<1	--	3.0

Table 1
Summary of Groundwater Analytical Data
Total Petroleum Hydrocarbons

Former Unocal Seattle Marketing Terminal
 3001 Elliott Avenue
 Seattle, Washington

Monitoring Well ¹	Date Sampled	LNAPL ²	BTEX (EPA Method 8020 or 8021B) (µg/L)				TPH (EPA Method 418.1) (mg/L)	NWTPH-Gx (mg/L)	NWTPH-D Extended ³ (mg/L)		Dissolved Lead (EPA 6000/7000 Series Method) (µg/L)
			B	T	E	X		Gasoline	Diesel	Heavy Oil	
								C ₇ - C ₁₂	C ₁₂ - C ₂₄	>C ₂₄	
Offsite Area RALs		No visible sheen	40	14,300	1,400	4,400	--	1	10	15	50
Offsite Area (continued)											
MW-35	10/26/89	--	33	1.1	<0.5	1.4	<0.5	--	--	--	<5
	01/16/90	--	<0.5	<0.5	<0.5	<0.5	<0.5	--	--	--	<5
	04/16/90	--	<0.5	<0.5	<0.5	<0.5	<1	--	--	--	<5
	07/25/90	--	<0.5	<0.5	<0.5	<0.5	<1	--	--	--	<5
	10/16/90	--	<0.5	<0.5	<0.5	<0.5	<1	--	--	--	<5
	01/17/91	--	<0.5	<0.5	<0.5	<0.5	--	<1	<1	--	<5
	04/16/91	--	<0.5	<0.5	<0.5	<0.5	--	<1	<1	--	<5
	09/17/91	--	<0.5	<0.5	<0.5	<0.5	--	<1	<1	--	2
	12/01/91	--	<0.5	<0.5	<0.5	<0.5	--	<1	<1	--	3.3
MW-36	10/26/89	--	330	1.9	2.5	8.0	2	--	--	--	<5
	01/16/90	--	95	3.1	<0.5	9.4	0.39	--	--	--	<5
	04/16/90	--	140	7.8	<0.5	<5.0	3.2	--	--	--	<5
	07/25/90	--	<0.5	<0.5	<0.5	17	4	--	--	--	<5
	10/16/90	--	8.0	<0.5	<0.5	4.8	8	--	--	--	<5
	01/17/91	--	1.2	5.6	12	58	6	11	20	--	<5
	04/16/91	--	1.7	6.4	<0.5	4.9	--	<1	<1	--	<2
	09/17/91	--	<0.5	<0.5	1.1	3.2	--	15	29	--	<2
	12/01/91	--	<0.5	<0.5	2.5	6.5	--	<1	<1	--	<3.0
	03/13/98	ND	<0.500	<0.500	<0.500	<1.00	--	0.609	12.5	2.69	--
	06/25/98	ND	<0.500	<0.500	<0.500	<2.50	--	0.345	<0.250	<0.750	<1.00
	09/03/98	ND	<0.800	<0.500	<0.750	<4.00	--	0.499	7.42	1.43	--
	12/14/98	ND	1.24	0.699	0.707	4.12	--	0.536	1.43/<0.250	<0.750/<0.750	--
	03/24/99	ND	1.96	<1.10	<1.40	<3.50	--	0.999	27.1/18.1	5.86/3.39	--
	07/01/99	ND	<0.500	<0.500	<0.500	<2.00	--	0.257 ⁴	1.28/<0.250	<0.750/<0.750	--
	09/29/99	ND	<0.500	<0.500	<5.00	<10.0	--	0.562 ⁴	4.63/2.01	0.849/<0.0750	--
	12/16/99	ND	0.813	<1.50	<5.00	<2.00	--	0.344	0.867/<0.250	<0.750/<0.750	--
	03/22/00	ND	<0.500	0.792	<0.500	<3.00	--	0.584	6.42/4.30	1.58/<0.750	--
	06/22/00 ⁵	ND	5.80	70.0	33.2	240	--	2.17	0.850/<0.250	<0.750/<0.750	--
	09/15/00	Sheen	<0.500	<2.39	<0.704	<5.46	--	0.923	9.25/6.10	1.70/0.927	--
	12/21/00	ND	0.636	<1.12	<0.500	<2.20	--	0.229	1.26/<0.250	<0.750/<0.750	--
	03/15/01	ND	2.00	<1.04	<0.500	<12.5	--	2.19	5.46/4.03	1.40/<0.750	--
	06/21/01	ND	<0.500	<0.500	<0.500	<1.00	--	0.207	0.643/<0.250	<0.750/<0.750	--
	09/25/01	Sheen	1.03	<0.500	<0.500	2.54	--	0.514	8.88/6.64	1.92/<0.750	--
	12/19/01	ND	1.49	<2.00	<1.00	<1.50	--	0.415	1.15/<0.250 ¹⁰	<0.750/<0.750 ¹⁰	--
	03/26/02	ND	1.01	<0.500	<0.500	1.9	--	0.38	1.47/0.794	<0.750/<0.750	--
	06/20/02	ND	0.618	<0.500	<0.500	<1.00	--	0.106	1.01/<0.250	<0.750/<0.750	--
09/19/02	Sheen	0.914	<0.500	<0.500	1.85	--	0.307	1.39 ¹³	<0.750 ⁶	--	
12/13/02	Sheen	<0.500	<0.500	<0.500	1.07	--	0.186	15.5	<0.750	--	
03/21/03	Sheen	0.846	<0.500	<0.500	2.4	--	0.398	3.25	<0.750	--	
6/19/2003 ¹⁴	Sheen	0.691	0.508	0.503	2.93	--	0.623 ⁷	6.09	1.27	--	
09/18/03	Sheen	<0.500	<0.500	<0.500	1.29	--	0.219	4.87	0.943	--	
12/02/03	Sheen	0.538	<0.500	<0.500	1.37	--	0.242	1.97	<0.750	--	

Table 1
Summary of Groundwater Analytical Data
Total Petroleum Hydrocarbons

Former Unocal Seattle Marketing Terminal
3001 Elliott Avenue
Seattle, Washington

Monitoring Well ¹	Date Sampled	LNAPL ²	BTEX (EPA Method 8020 or 8021B) (µg/L)				TPH (EPA Method 418.1) (mg/L)	NWTPH-Gx (mg/L)	NWTPH-D Extended ³ (mg/L)		Dissolved Lead (EPA 6000/7000 Series Method) (µg/L)
			B	T	E	X		Gasoline	Diesel	Heavy Oil	
								C ₇ - C ₁₂	C ₁₂ - C ₂₄	>C ₂₄	
Offsite Area RALs		No visible sheen	40	14,300	1,400	4,400	--	1	10	15	50
Offsite Area (continued)											
MW-41	09/18/90	--	--	--	--	--	2	--	--	--	<5
	10/16/90	--	<0.5	<0.5	<0.5	<0.5	<1	--	--	--	<5
	01/17/91	--	<0.5	<0.5	1.2	3.9	<1	1	<1	--	<5
	04/16/91	--	3.5	0.9	4.5	1.4	--	<1	<1	--	<2
	09/17/91	--	<0.5	<0.5	<0.5	<0.5	--	<1	4	--	<2
	12/10/91	--	<0.5	<0.5	<0.5	<0.5	--	<1	<1	--	<3.0
	06/29/98	ND	<0.500	<0.500	<0.500	<1.00	--	<0.0500	<0.250	<0.750	--
	12/15/98	ND	<0.500	<0.500	<0.500	<1.00	--	<0.0500	<0.250	<0.750	--
	07/01/99	ND	<0.500	<0.500	<0.500	<1.00	--	<0.0500	<0.250	<0.750	--
	12/16/99	ND	<0.500	<0.500	<5.00	<1.00	--	<0.0500	<0.250	<0.750	--
	06/22/00 ⁸	ND	<0.500	6.55	3.97	35.8	--	0.433	<0.250	<0.750	--
	12/22/00	ND	<0.500	<0.500	<0.500	<1.00	--	<0.0500	<0.250	<0.750	--
	06/22/01	ND	<0.500	<0.500	<0.500	<1.00	--	<0.0500	<0.250	<0.750	--
	12/18/01	ND	<0.500	<2.00	<1.00	<1.50	--	<0.100	<0.250 ¹⁰	<0.750 ¹⁰	--
06/20/02	ND	<0.500	<0.500	<0.500	<1.00	--	<0.0500	<0.250	<0.750	--	
12/13/02	ND	<0.500	<0.500	<0.500	<1.00	--	<0.0500	<0.250	<0.750	--	
MW-42	10/16/90	--	<0.5	<0.5	<0.5	<0.5	<1	--	--	--	<5
	01/17/91	--	<0.5	<0.5	<0.5	<0.5	--	<1	<1	--	<5
	04/16/91	--	<0.5	<0.5	<0.5	<0.5	--	<1	<1	--	<2
	09/17/91	--	<0.5	<0.5	<0.5	<0.5	--	<1	<1	--	3
	12/10/91	--	<0.5	<0.5	<0.5	<0.5	--	<1	<1	--	<3.0
MW-43	10/16/90	--	2.9	<0.5	17	5.3	<1	--	--	--	<5
	01/17/91	--	<0.5	<0.5	<0.5	<0.5	--	<1	<1	--	<5
	04/16/91	--	<0.5	<0.5	0.7	0.6	--	<1	<1	--	<2
	09/17/91	--	<0.5	<0.5	<0.5	<0.5	--	3	9	--	3
	12/10/91	--	<0.5	<0.5	<0.5	<0.5	--	<1	<1	--	<3.0
MW-52	06/25/98	ND	<0.500	<0.500	<0.500	<1.00	--	<0.0500	<0.250	<0.750	<1.00
	12/15/98	ND	<0.500	<0.500	<0.500	<1.00	--	<0.0500	<0.250	<0.750	--
	07/01/99	ND	<0.500	<0.500	<0.500	<1.00	--	<0.0500	0.522/<0.250	<0.750/<0.750	--
	12/16/99	ND	<0.500	<0.500	<0.500	<1.00	--	<0.0500	0.250/<0.250	<0.750/<0.750	--
	06/22/00	ND	<0.500	<0.500	<0.500	<1.00	--	<0.0500	<0.250	<0.750	--
	12/21/00	ND	<0.500	<0.500	<0.500	<1.00	--	<0.0500	0.257/<0.250	<0.750/<0.750	--
	06/22/01	ND	<0.500	<0.500	<0.500	<1.00	--	<0.0500	<0.250	<0.750	--
	12/19/01	ND	<0.500	<2.00	<1.00	<1.50	--	<0.100	0.325/<0.250 ¹⁰	<0.750/<0.750 ¹⁰	--
	06/20/02	ND	<0.500	<0.500	<0.500	<1.00	--	<0.0500	0.289/<0.250	<0.750/<0.750	--
12/13/02	ND	<0.500	<0.500	<0.500	<1.00	--	<0.0500	<0.250	<0.750	--	
12/02/03	ND	<0.500	<0.500	<0.500	<1.00	--	<0.0500	<0.250	<0.750	--	
MW-67	03/13/98	ND	<0.500	0.658	1.57	3.37	--	0.237	<0.250	<0.750	--
	06/24/98	ND	<0.500	1.44	<0.500	<1.00	--	0.0597	<0.250	<0.750	<1.00
	09/03/98	ND	<1.00	<0.500	0.913	<1.00	--	0.0661	0.287	<0.750	--
	12/14/98	ND	<0.800	<2.00	2.44	4.87	--	0.432	0.813/0.328	<0.750/<0.750	--
	03/24/99	ND	4.84	<0.500	<0.500	<1.00	--	0.158	0.566/<0.250	<0.750/<0.750	--
	07/01/99	ND	<4.20	<1.00	2.68	4.66	--	0.341	0.833/0.275	<0.750/<0.750	<20.0
	09/29/99	ND	0.554	1.88	0.884	1.55	--	0.239	0.544/<0.250	<0.750/<0.750	--
	12/16/99	ND	<8.20	<1.25	1.9	8.65	--	0.561	0.807/<0.250	<0.750/<0.750	--
	03/22/00	ND	<0.500	1.71	0.533	1.46	--	0.156	0.651/0.292	<0.750/<0.750	--
	06/22/00	ND	4.74	1.02	1.65	4.53	--	0.395	0.951/<0.250	<0.750/<0.750	<10.0

Table 1
Summary of Groundwater Analytical Data
Total Petroleum Hydrocarbons

Former Unocal Seattle Marketing Terminal
3001 Elliott Avenue
Seattle, Washington

Monitoring Well ¹	Date Sampled	LNAPL ²	BTEX (EPA Method 8020 or 8021B) (µg/L)				TPH (EPA Method 418.1) (mg/L)	NWTPH-Gx (mg/L)	NWTPH-D Extended ³ (mg/L)		Dissolved Lead (EPA 6000/7000 Series Method) (µg/L)
			B	T	E	X		Gasoline	Diesel	Heavy Oil	
								C ₇ - C ₁₂	C ₁₂ - C ₂₄	>C ₂₄	
Offsite Area RALs		No visible sheen	40	14,300	1,400	4,400	--	1	10	15	50
Offsite Area (continued)											
MW-67 (continued)	09/15/00	ND	<3.00	<0.500	<0.520	<1.81	--	0.157	0.607/<0.250	<0.750/<0.750	--
	12/21/00	ND	7.35	<1.38	<2.04	5.73	--	0.413	0.646/<0.250	<0.750/<0.750	--
	03/15/01	ND	<0.500	<0.500	<0.624	<1.77	--	0.165	0.524/<0.250	<0.750/<0.750	--
	06/21/01	ND	<0.500	1.21	2.47	2.61	--	0.403	0.479/<0.250	<0.750/<0.750	<1.00
	09/25/01	ND	3.45	<0.500	1.46	2.10	--	0.230	0.585/0.295	<0.750/<0.750	--
	12/19/01	ND	13.2	<2.00	1.46	2.97	--	1.01	0.760/<0.250 ¹⁰	<0.750/<0.750 ¹⁰	--
	03/26/02	ND	3.01	<0.500	0.671	1.09	--	0.178	0.672/<0.250	0.839/<0.750	--
	06/19/02	ND	<0.500	<0.500	<0.500	1.21	--	<0.0500	<0.250	<0.750	<1.00
	09/19/02	ND	<0.500	<0.500	<0.500	<1.00	--	<0.0500	<0.250 ¹³	<0.750 ¹³	--
	12/13/02	ND	<0.500	<0.500	0.751	2.99	--	<0.0500	<0.250	<0.750	--
	03/21/03	ND	<0.500	<0.500	0.751	<1.00	--	<0.0500	0.352	1.44	--
	06/19/03	ND	<0.500	<0.500	<0.500	<1.00	--	<0.0500	<0.250	<0.750	--
	09/18/03	ND	<0.500	<0.500	<0.500	<1.00	--	<0.0500	<0.250	<0.750	--
	12/03/03	ND	<0.500	<0.500	<0.500	<1.00	--	<0.0500	<0.250	<0.750	--
MW-70	06/25/98	ND	<0.500	<0.500	<0.500	<1.00	--	<0.0500	<0.250	<0.750	<1.00
	12/15/98	ND	<0.500	<0.500	<0.500	<1.00	--	<0.0500	0.488/<0.250	<0.750/<0.750	--
	07/01/99	ND	<0.500	<0.500	<0.500	<1.00	--	<0.0500	<0.250	<0.750	<20.0
	12/16/99	ND	<0.500	<0.500	<0.500	<1.00	--	<0.0500	0.392/<0.250	<0.750/<0.750	--
	06/22/00 ⁸	ND	<0.500	1.31	0.610	3.83	--	0.0632	<0.250 ¹³	<0.750 ¹³	<1.00
	12/21/00	ND	<0.500	<0.500	<0.500	<1.00	--	<0.0500	<0.250	<0.750	--
	06/21/01	ND	<0.500	<0.500	<0.500	<1.00	--	<0.0500	<0.250	<0.750	--
	12/19/01	ND	<0.500	<2.00	<1.00	<1.50	--	<0.100	0.372/<0.250 ¹⁰	<0.750/<0.750 ¹⁰	--
	06/19/02	ND	<0.500	<0.500	<0.500	<1.00	--	<0.0500	<0.250	<0.750	--
	12/13/02	ND	<0.500	<0.500	<0.500	<1.00	--	<0.0500	<0.250	<0.750	--
	12/02/03	ND	<0.500	<0.500	<0.500	<1.00	--	<0.0500	<0.250	<0.750	--
12/06/04	ND	<0.500	<0.500	<0.500	<1.00	--	<0.0500	<0.250	<0.750	--	
MW-71	06/25/98	ND	<0.500	<0.500	<0.500	<1.00	--	<0.0500	<0.250	<0.750	<1.00
	12/14/98	ND	<0.500	<0.500	<0.500	<1.00	--	<0.0500	3.77/<0.250	<0.750/<0.750	--
	07/01/99	ND	<0.500	<0.500	<0.500	<1.00	--	<0.0500	<0.250	<0.750	<20.0
	12/16/99	ND	<0.500	<0.500	<0.500	<1.00	--	<0.0500	0.430 ¹⁵	<0.904 ¹⁵	--
	06/22/00 ⁸	ND	<0.500	0.980	0.522	3.08	--	0.0746	<0.250	<0.750	<1.00
	12/21/00	ND	<0.500	<0.500	<0.500	<1.00	--	<0.0500	<0.250	<0.750	--
	06/21/01	ND	<0.500	<0.500	<0.500	<1.00	--	<0.0500	<0.250	<0.750	<1.00
	12/19/01	ND	<0.500	<2.00	<1.00	<1.50	--	<0.100	0.514/<0.250 ¹⁰	<0.750/<0.750 ¹⁰	--
	06/19/02	ND	<0.500	<0.500	<0.500	<1.00	--	<0.0500	<0.250	<0.750	<1.00
	12/13/02	ND	<0.500	<0.500	<0.500	<1.00	--	<0.0500	<0.250	<0.750	--
12/02/03	ND	<0.500	<0.500	<0.500	<1.00	--	<0.0500	<0.250	<0.750	--	
MW-72	03/13/98	ND	<11.0	<3.00	<3.00	<11.0	--	1.30	0.369	<0.750	--
	06/24/98	ND	<1.00	<1.00	<0.500	<2.00	--	0.699	0.286	<0.750	<1.00
	09/03/98	ND	<9.38	<2.50	<2.50	<4.50	--	1.03	3.11	1.78	--
	12/14/98	Sheen	5.45	0.644	1.07	1.68	--	0.196	0.847/<0.250	<0.750/<0.750	--
	03/24/98	Sheen	4.69	<0.950	<0.950	<3.30	--	0.269	1.74/0.744	1.42/<0.750	--
	07/01/99	ND	<2.80	<0.900	<0.500	<2.26	--	0.248	1.05/<0.250	<0.750/<0.750	<1.00
	09/29/99	Sheen	5.71	2.71	0.68	5.01	--	0.481	1.86/0.424 ¹³	1.01/<0.750 ¹³	--
	12/16/99	Sheen	<7.40	<1.40	<0.500	6.87	--	0.421	0.905/<0.475	<1.43/<1.43	--
	03/22/00	ND	2.88	5.40	0.846	6.42	--	0.596	1.40/0.462	<0.750/<0.750	--
	06/22/00	ND	5.98	1.11	0.599	2.38	--	0.344	1.11/<0.250	<0.750/<0.750	<1.00
	09/15/00	ND	1.47	<1.20	<0.525	<5.42	--	0.547	1.35/0.427	<0.750/<0.750	--

Table 1
Summary of Groundwater Analytical Data
Total Petroleum Hydrocarbons

Former Unocal Seattle Marketing Terminal
 3001 Elliott Avenue
 Seattle, Washington

Monitoring Well ¹	Date Sampled	LNAPL ²	BTEX (EPA Method 8020 or 8021B) (µg/L)				TPH (EPA Method 418.1) (mg/L)	NWTPH-Gx (mg/L)	NWTPH-D Extended ³ (mg/L)		Dissolved Lead (EPA 6000/7000 Series Method) (µg/L)
			B	T	E	X		Gasoline	Diesel	Heavy Oil	
								C ₇ - C ₁₂	C ₁₂ - C ₂₄	>C ₂₄	
Offsite Area RALs		No visible sheen	40	14,300	1,400	4,400	--	1	10	15	50
Offsite Area (continued)											
MW-72 (continued)	12/21/00	ND	5.71	<1.00	<0.500	4.46	--	0.422	0.698/<0.250	<0.750/<0.750	--
	03/15/01	ND	1.90	<1.06	<0.791	<3.29	--	0.454	1.47/<0.250	0.752/<0.750	--
	06/21/01	ND	1.08	1.29	<0.500	2.78	--	0.274	0.591/<0.250	<0.750/<0.750	--
	09/25/01	Sheen	7.98	0.679	1.07	3.24	--	0.695	3.37/1.35	1.90/0.942	--
	12/19/01	ND	12.2	<2.00	<1.00	3.21	--	0.835	1.59/0.261 ¹⁰	<0.750/<0.750 ¹⁰	--
	03/26/02	Sheen	6.4	0.753	<0.500	3.88	--	0.47	1.05/<0.250	<0.750/<0.750	--
	06/19/02	ND	10.3	0.722	1.48	4.60	--	0.697	3.19/<0.250	<0.750/<0.750	--
	09/19/02	Sheen	13.3	0.798	2.29	4.29	--	0.828	0.769 ¹¹	<0.750 ¹¹	--
	12/13/02	Sheen	8.35	0.747	2.27	6.10	--	0.594	4.15	2.94	--
	03/21/03	Sheen	3.2	<0.500	0.909	1.29	--	0.360	0.281	<0.750	--
	06/19/03	Sheen	8.28	0.509	1.79	3.82	--	0.476	1.61	1.25	--
	09/18/03	Sheen	4.54	<0.500	0.931	4.28	--	0.522	1.17	0.775	--
	12/02/03	Sheen	2.26	<0.500	<0.500	2.34	--	0.439	1.20	0.979	--
	03/09/04	Sheen	0.738	<0.500	<0.500	1.31	--	0.133	0.315	<0.750	--
	06/03/04	Sheen	0.656	<0.500	<0.500	<1.00	--	0.195	0.265	<0.750	--
	09/03/04	ND	1.41	<0.500	<0.500	1.72	--	0.294	0.275	<0.750	--
	12/06/04	ND	1.27	<0.500	<0.500	1.47	--	0.238	<0.250	<0.750	--
	03/04/05	ND	1.07	<0.500	<0.500	2.20	--	0.202	0.524	<0.750	--
06/03/05	ND	1.10	<0.500	<0.500	<1.00	--	0.141	<0.250	<0.750	--	
MW-73	03/12/98	ND	<0.500	<0.500	<0.500	<1.00	--	<0.0500	<0.250	<0.750	--
	06/29/98	ND	<0.500	<0.500	<0.500	<1.00	--	<0.0500	<0.250	<0.750	<1.00
	09/03/98	ND	<0.500	<0.500	<0.500	1.30	--	<0.0500	<0.250	<0.750	--
	12/15/98	ND	<0.500	<0.500	<0.500	<1.00	--	<0.0500	0.388/<0.250	<0.750/<0.750	--
	03/24/99	ND	<0.500	<0.500	<0.500	<1.00	--	<0.0500	0.665/<0.250	<0.750/<0.750	--
	06/29/99	ND	<0.500	<0.500	<0.500	<1.00	--	<0.0500	0.370/<0.250	<0.750/<0.750	<1.00
	09/29/99	ND	<0.500	<0.500	<0.500	<1.00	--	<0.0500	0.430/<0.250	<0.750/<0.750	--
	12/15/99	ND	<0.500	<0.500	<0.500	<1.00	--	<0.0500	0.830/<0.250	<0.750/<0.750	--
	03/22/00	ND	<0.500	<0.500	<0.500	<1.00	--	<0.0500	0.559/<0.250	<0.750/<0.750	--
	06/22/00	ND	<0.500	<0.500	<0.500	<1.00	--	0.0737	0.407/<0.250	<0.750/<0.750	<10.0
	09/14/00	ND	<0.500	<0.500	<0.500	<1.00	--	<0.0500	0.298/<0.250	<0.750/<0.750	--
	12/22/00	ND	<0.500	<0.500	<0.500	<1.00	--	<0.0500	<0.250	<0.750	--
	03/15/01	ND	<0.500	<0.500	<0.500	<1.00	--	<0.0500	<0.250	<0.750	--
	06/22/01	ND	<0.500	<0.500	<0.500	<1.00	--	<0.0500	<0.250	<0.750	--
	09/25/01	ND	<0.500	<0.500	<0.500	<1.00	--	<0.0500	<0.250	<0.750	--
	12/18/01	ND	<0.500	<2.00	<1.00	<1.50	--	<0.100	0.693/<0.250 ¹⁰	<0.750/<0.750 ¹⁰	--
03/26/02	ND	<0.500	<0.500	<0.500	<1.00	--	<0.0500	0.618/<0.250	<0.750/<0.750	--	
06/20/02	ND	<0.500	<0.500	<0.500	<1.00	--	<0.0500	0.287/<0.250	<0.750/<0.750	<1.00	

Table 1
Summary of Groundwater Analytical Data
Total Petroleum Hydrocarbons

Former Unocal Seattle Marketing Terminal
3001 Elliott Avenue
Seattle, Washington

Monitoring Well ¹	Date Sampled	LNAPL ²	BTEX (EPA Method 8020 or 8021B) (µg/L)				TPH (EPA Method 418.1) (mg/L)	NWTPH-Gx (mg/L)	NWTPH-D Extended ³ (mg/L)		Dissolved Lead (EPA 6000/7000 Series Method) (µg/L)
			B	T	E	X		Gasoline	Diesel	Heavy Oil	
								C ₇ - C ₁₂	C ₁₂ - C ₂₄	>C ₂₄	
Offsite Area RALs		No visible sheen	40	14,300	1,400	4,400	--	1	10	15	50
Offsite Area (continued)											
MW-74	03/12/98	ND	<0.500	<0.500	<0.500	<1.00	--	<0.0500	<0.250	<0.750	--
	06/29/98	ND	<0.500	<0.500	<0.500	<1.00	--	<0.0500	<0.250	<0.750	1.93
	09/03/98	ND	<0.500	<0.500	<0.500	1.02	--	<0.0500	0.29	1.07	--
	12/15/98	ND	<0.500	<0.500	<0.500	<1.00	--	<0.0500	0.517/<0.250	<0.750/<0.750	--
	03/24/99	ND	<0.500	<0.500	<0.500	<1.00	--	<0.0500	0.600/<0.250	0.993/<0.750	--
	06/29/99	ND	<0.500	<0.500	<0.500	<1.00	--	<0.0500	0.251/<0.250	<0.750/<0.750	<1.00
	09/29/99	ND	<0.500	<0.500	<0.500	<1.00	--	<0.0500	0.462/<0.250	<0.750/<0.750	--
	12/15/99	ND	<0.500	<0.500	<0.500	<1.00	--	<0.0500	0.659/<0.250	<0.750/<0.750	--
	03/22/00	ND	<0.500	<0.500	<0.500	<1.00	--	<0.0500	0.500/<0.250	0.923/<0.750	--
	06/22/00	ND	<0.500	<0.500	<0.500	<1.00	--	<0.0500	<0.234	<0.748	<1.00
	09/14/00	ND	<0.500	<0.500	<0.500	<1.00	--	<0.0500	<0.250	<0.750	--
	12/22/00	ND	<0.500	<0.500	<0.500	<1.00	--	<0.0500	<0.250	<0.750	--
	03/15/01	ND	<0.500	<0.500	<0.500	<1.00	--	<0.0500	0.273/<0.250	0.863/<0.750	--
	06/22/01	ND	<0.500	<0.500	<0.500	<1.00	--	<0.0500	0.505/<0.250	<0.750/<0.750	--
	09/25/01	ND	<0.500	<0.500	<0.500	<1.00	--	<0.0500	<0.250	<0.750	--
	12/18/01	ND	<0.500	<2.00	<1.00	<1.50	--	<0.100	1.06/<0.250 ¹⁰	1.11/<0.750 ¹⁰	--
03/26/02	ND	<0.500	<0.500	<0.500	<1.00	--	<0.0500	0.430/<0.250	<0.750/<0.750	--	
06/20/02	ND	<0.500	<0.500	<0.500	<1.00	--	<0.0500	0.305/<0.250	<0.750/<0.750	<1.00	
MW-75	03/12/98	ND	<0.500	<0.500	<0.500	<1.00	--	<0.0500	<0.250	<0.750	--
	06/29/98	ND	<0.500	<0.500	<0.500	<1.00	--	<0.0500	<0.250	<0.750	<1.00
	09/03/98	ND	<0.500	<0.500	<0.500	<1.00	--	<0.0500	<0.250	<0.750	--
	12/15/98	ND	<0.500	<0.500	<0.500	1.33	--	<0.0500	<0.250	<0.750	--
	03/24/99	ND	<0.500	<0.500	<0.500	<1.00	--	<0.0500	<0.250	<0.750	--
	06/29/99	ND	<0.500	<0.500	<0.500	<1.00	--	<0.0500	<0.250	<0.750	<1.00
	09/29/99	ND	<0.500	<0.500	<0.500	<1.00	--	<0.0500	<0.250	<0.750	--
	12/15/99	ND	<0.500	<0.500	<0.500	<1.00	--	<0.0500	<0.250	<0.750	--
	03/22/00	ND	<0.500	<0.500	<0.500	<1.00	--	<0.0500	<0.250	<0.750	--
	06/22/00	ND	<0.500	<0.500	<0.500	<1.00	--	<0.0500	<0.239	<0.744	<1.00
	09/14/00	ND	<0.500	<0.500	<0.500	<1.00	--	<0.0500	<0.250	<0.750	--
	12/22/00	ND	<0.500	<0.500	<0.500	<1.00	--	<0.0500	<0.250	<0.750	--
	03/15/01	ND	<0.500	<0.500	<0.500	<1.00	--	<0.0500	<0.250	<0.750	--
	06/22/01	ND	<0.500	<0.500	<0.500	<1.00	--	<0.0500	<0.250	<0.750	<1.00
	09/25/01	ND	<0.500	<0.500	<0.500	<1.00	--	<0.0500	<0.250	<0.750	--
	12/18/01	ND	<0.500	<2.00	<1.00	<1.50	--	<0.100	<0.250 ¹⁰	<0.750 ¹⁰	--
03/26/02	ND	<0.500	<0.500	<0.500	<1.00	--	<0.0500	<0.250	<0.750	--	
06/20/02	ND	<0.500	<0.500	<0.500	<1.00	--	<0.0500	<0.250	<0.750	<1.00	
MW-76	06/24/98	ND	<0.500	<0.500	<0.500	<1.00	--	<0.0500	<0.250	<0.750	<5.00
	09/03/98	ND	0.962	0.774	0.609	<1.00	--	0.0593	0.361	<0.750	--
	12/14/98	ND	<1.00	<0.500	1.29	<1.00	--	0.0779	0.789/<0.250	<0.750/<0.750	--
	03/24/98	ND	<1.00	<0.500	<0.500	<1.00	--	<0.0500	<0.250	<0.750	--
	07/01/99	ND	<1.20	<0.500	1.64	1.31	--	0.0998	0.786/<0.250	<0.750/<0.750	<20.0
	09/29/99	ND	<0.500	0.538	0.583	<1.00	--	0.0577	0.632/<0.250	<0.750/<0.750	--
	12/16/99	ND	0.582	<0.500	0.631	<1.00	--	0.728	0.667/<0.250	<0.750/<0.750	--
	03/22/00	ND	<0.500	<0.500	<0.500	<1.00	--	<0.0500	0.640/<0.250	<0.750/<0.750	--
	06/22/00	ND	<0.500	<0.500	<0.500	<1.00	--	<0.0500	0.259/<0.250	<0.750/<0.750	<1.00
	09/15/00	ND	<0.500	<0.500	<0.500	<1.00	--	<0.0500	0.605/<0.250	<0.750/<0.750	--
	12/21/00	ND	<0.600	<0.500	0.628	<1.00	--	0.784	0.606/<0.250	<0.750/<0.750	--
	03/15/01	ND	0.506	1.35	<0.500	1.22	--	<0.0500	0.278/<0.250	<0.750/<0.750	--

Table 1
Summary of Groundwater Analytical Data
Total Petroleum Hydrocarbons

Former Unocal Seattle Marketing Terminal
3001 Elliott Avenue
Seattle, Washington

Monitoring Well ¹	Date Sampled	LNAPL ²	BTEX (EPA Method 8020 or 8021B) (µg/L)				TPH (EPA Method 418.1) (mg/L)	NWTPH-Gx (mg/L)	NWTPH-D Extended ³ (mg/L)		Dissolved Lead (EPA 6000/7000 Series Method) (µg/L)
			B	T	E	X		Gasoline	Diesel	Heavy Oil	
								C ₇ - C ₁₂	C ₁₂ - C ₂₄	>C ₂₄	
Offsite Area RALs		No visible sheen	40	14,300	1,400	4,400	--	1	10	15	50
Offsite Area (continued)											
MW-76 (continued)	06/21/01	ND	<0.500	<0.500	0.808	<1.00	--	<0.0500	<0.250	<0.750	--
	09/25/01	ND	0.508	<0.500	0.774	<1.00	--	<0.0500	0.461/0.316	<0.750/<0.750	--
	12/19/01	ND	<0.500	<2.00	<1.00	<1.50	--	0.114	0.549/<0.250	<0.750/<0.750	--
	03/26/02	ND	<0.500	<0.500	<0.500	<1.00	--	<0.0500	0.317/<0.250	<0.750/<0.750	--
	06/19/02	ND	<0.500	<0.500	<0.500	1.11	--	<0.0500	<0.250	<0.750	--
	12/13/02	ND	<0.500	<0.500	<0.500	<1.00	--	<0.0500	<0.250	<0.750	--
	12/03/03	ND	<0.500	<0.500	<0.500	<1.00	--	<0.0500	<0.250	<0.750	--
	12/06/04	ND	<0.500	<0.500	<0.500	<1.00	--	<0.0500	<0.250	<0.750	--
MW-200 Duplicate	03/08/07	Sheen	2.80	0.5	3.7	4	--	0.39	0.46	<0.095	--
	06/07/07	ND	2.4	0.6	2.1	2.5	--	0.250	0.310	<0.095	<0.037
	09/26/07	ND	1.6	<0.5	0.9	<1.5	--	0.230	0.270	<0.100	<0.047
	09/26/07	ND	1.7	<0.5	0.8	<1.5	--	0.230	0.310	0.120	<0.047
	11/28/07	ND	2.0	<0.5	1.2	2.1	--	0.250	0.330	<0.100	0.064
	02/13/08	ND	3.44	<0.500	1.19	1.79	--	0.497	<0.236	<0.472	<1.00
	05/13/08	ND	2.70	<0.500	1.15	2.07	--	0.426	<0.240	<0.481	<1.00
	09/03/08	ND	<0.500	0.883	1.46	<1.00	--	0.337	<0.236	<0.472	<1.00
	12/04/08	ND	3.19	<0.500	0.975	2.01	--	0.427	<0.238	<0.476	<1.00
	02/18/09	ND	2.54	<0.500	0.619	1.14	--	0.355	<0.250	<0.500	<1.00
	05/13/09	ND	3.43	<0.500	1.12	1.91	--	0.513	<0.278	<0.556	<1.00
	09/11/09	ND	<0.500	<0.500	0.52	<1.00	--	0.360	<0.248	<0.495	<2.0
	04/14/10	ND	<0.50	<0.50	0.54	<2.0	--	0.35	0.31	<0.25	<2.0
	09/22/10	ND	<0.50	<0.50	0.56	1.2	--	0.43	0.56	<0.25	<2.0
MW-201 Duplicate	03/08/07	Sheen	0.50	<0.5	<0.5	<1.5	--	0.076	0.51	0.18	--
	06/07/07	ND	0.50	<0.5	<0.5	<1.5	--	0.08	0.53	0.17	0.1
	06/07/07	ND	0.60	<0.5	<0.5	<1.5	--	0.069	0.39	0.13	--
	09/27/07	Sheen	<0.5	<0.5	<0.5	<1.5	--	0.076	0.810	0.470	0.080
	11/27/07	ND	0.6	<0.5	<0.5	<1.5	--	0.065	0.390	0.150	0.098
	02/12/08	ND	0.813	<0.500	<0.500	<1.00	--	0.111	<0.243	<0.485	<1.00
	05/14/08	Sheen	0.616	<0.500	<0.500	<1.00	--	0.110	<0.236	<0.472	<1.00
	09/05/08	ND	<0.500	0.517	<0.500	<1.00	--	0.153	<0.238	<0.476	<1.00
	12/05/08	ND	2.24	0.511	<0.500	1.87	--	0.323	<0.248	<0.495	<1.00
	02/17/09	ND	0.552	<0.500	<0.500	<1.00	--	0.0887	<0.263	<0.526	<1.00
	05/13/09	ND	2.42	<0.500	<0.500	1.76	--	0.372	<0.250	<0.500	<1.00
	09/11/09	ND	<0.500	<0.500	<0.500	1.4	--	0.43	<0.248	<0.495	<2.0
	04/14/10	ND	<0.50	<0.50	<0.50	<2.0	--	0.15	0.17	<0.25	<2.0
	09/22/10	ND	<0.50	<0.50	<0.50	1.1	--	0.27	0.47	<0.25	<2.0

Table 1
Summary of Groundwater Analytical Data
Total Petroleum Hydrocarbons

Former Unocal Seattle Marketing Terminal
3001 Elliott Avenue
Seattle, Washington

Monitoring Well ¹	Date Sampled	LNAPL ²	BTEX (EPA Method 8020 or 8021B) (µg/L)				TPH (EPA Method 418.1) (mg/L)	NWTPH-Gx (mg/L)	NWTPH-D Extended ³ (mg/L)		Dissolved Lead (EPA 6000/7000 Series Method) (µg/L)
			B	T	E	X		Gasoline	Diesel	Heavy Oil	
								C ₇ - C ₁₂	C ₁₂ - C ₂₄	>C ₂₄	
Offsite Area RALs		No visible sheen	40	14,300	1,400	4,400	--	1	10	15	50
Offsite Area (continued)											
MW-202	03/08/07	ND	0.60	<0.5	<0.5	<1.5	--	0.16	0.18	<0.095	--
	06/07/07	ND	<0.5	<2.0 ¹⁶	0.9	<1.5	--	0.072	0.150	<0.095	0.19
	09/27/07	ND	<0.5	<0.5	<0.5	<1.5	--	0.110	0.380	0.360	<0.24
	11/26/07	ND	<0.5	<0.5	0.8	<1.5	--	0.100	0.290	0.120	0.37
	02/12/08	ND	<0.500	<0.500	0.751	<1.00	--	0.249	<0.240	<0.481	<1.00
	05/13/08	ND	<0.500	<0.500	0.620	<1.00	--	0.188	<0.236	<0.472	<1.00
	09/04/08	ND	<0.500	<0.500	1.55	<1.00	--	0.135	<0.238	<0.476	<1.00
	12/04/08	ND	<0.500	<0.500	<0.500	1.34	--	0.132	<0.245	<0.490	<1.00
	02/18/09	ND	<0.500	<0.500	0.583	<1.00	--	0.314	<0.245	<0.490	<1.00
	05/13/09	ND	<0.500	<0.500	<0.500	<1.00	--	0.233	<0.243	<0.485	<1.00
	09/11/09	ND	<0.500	<0.500	<0.500	<1.00	--	0.120	<0.245	<0.490	<2.0
	04/14/10	ND	<0.50	<0.50	<0.50	<2.0	--	0.10	<0.12	<0.25	<2.0
	09/22/10	ND	<0.50	<0.50	<0.50	<2.0	--	0.090	<0.12	<0.25	<2.0
	MW-203	03/08/07	ND	<0.5	<0.5	<0.5	<1.5	--	<0.048	0.32	<0.095
06/07/07		ND	<0.5	<0.5	<0.5	<1.5	--	<0.0500	0.150	<0.097	0.045
09/28/07		ND	<0.5	<0.5	<0.5	<1.5	--	<0.500	0.400	0.270	<0.047
11/27/07		ND	<0.5	<0.5	<0.5	<1.5	--	<0.050	0.290	<0.100	0.058
02/12/08		ND	<0.500	<0.500	<0.500	<1.00	--	<0.050	<0.240	<0.481	<1.00
Duplicate 02/12/08		ND	<0.500	<0.500	<0.500	<1.00	--	<0.050	<0.236	<0.472	<1.00
05/14/08		ND	<0.500	<0.500	<0.500	<1.00	--	<0.050	<0.243	<0.485	<1.00
Duplicate 05/14/08		ND	<0.500	<0.500	<0.500	<1.00	--	<0.050	--	--	--
09/03/08		ND	<0.500	<0.500	<0.500	<1.00	--	<0.050	<0.236	<0.472	<1.00
12/04/08		ND	<0.500	<0.500	<0.500	<1.00	--	<0.050	<0.240	<0.481	<1.00
02/17/09		ND	<0.500	<0.500	<0.500	<1.00	--	<0.050	<0.236	<0.472	<1.00
05/13/09		ND	<0.500	<0.500	<0.500	<1.00	--	<0.050	<0.243	<0.485	<1.00
09/11/09		ND	<0.500	<0.500	<1.00	<1.00	--	0.082	<0.248	<0.495	<2.0
04/14/10		ND	<0.50	<0.50	<0.50	<2.0	--	<0.050	<0.12	<0.25	<2.0
09/22/10		ND	<0.50	<0.50	<0.50	<2.0	--	0.058	<0.12	<0.24	<2.0

Table 1
Summary of Groundwater Analytical Data
Total Petroleum Hydrocarbons

Former Unocal Seattle Marketing Terminal
3001 Elliott Avenue
Seattle, Washington

Monitoring Well ¹	Date Sampled	LNAPL ²	BTEX (EPA Method 8020 or 8021B) (µg/L)				TPH (EPA Method 418.1) (mg/L)	NWTPH-Gx (mg/L)	NWTPH-D Extended ³ (mg/L)		Dissolved Lead (EPA 6000/7000 Series Method) (µg/L)	
			B	T	E	X		Gasoline	Diesel	Heavy Oil		
								C ₇ - C ₁₂	C ₁₂ - C ₂₄	>C ₂₄		
Offsite Area RALs		No visible sheen	40	14,300	1,400	4,400	--	1	10	15	50	
Offsite Area (continued)												
MW-204	03/08/07	Sheen	1.00	0.9	<0.5	<1.5	--	0.47	0.89	0.14	--	
	06/07/07	ND	1.40	1.8	<0.5	2.6	--	0.670	1.400	0.170	<0.037	
	09/28/07	ND	0.70	0.9	<0.5	1.6	--	0.640	1.000	0.260	<0.24	
	11/27/07	ND	0.9	0.8	0.9	<5.0 ¹⁶	--	0.670	0.700	0.160	<0.047	
	02/12/08	ND	1.76	1.09	<0.500	2.12	--	0.713	<0.240	<0.481	<1.00	
	05/14/08	ND	1.32	1.71	<0.500	4.17	--	0.782	0.310	0.784	<1.00	
	09/03/08	ND	4.42	1.06	3.07	1.47	--	1.070	0.384	<0.476	<1.00	
	10/01/08	ND	--	--	--	--	--	0.796	--	--	--	
	12/04/08	ND	1.45	1.20	1.05	4.22	--	0.869	0.291	<0.495	<1.00	
	02/17/09	ND	1.48	1.32	1.82	7.50	--	1.060	0.341	<0.500	<1.00	
	Duplicate	02/17/09	ND	1.54	1.30	1.81	7.45	--	1.120	0.332	<0.556	<1.00
		05/13/09	ND	1.93	1.55	1.86	4.79	--	1.190	0.593	<0.500	<1.00
	Duplicate	05/13/09	ND	1.82	1.58	1.88	7.70	--	1.230	0.553	<0.556	<1.00
		09/11/09	ND	<0.500	1.10	<0.500	1.8	--	1.200	0.396	<0.495	<2.0
	Duplicate	09/11/09	ND	<0.500	1.10	<0.500	1.8	--	1.100	0.393	<0.495	<2.0
		04/14/10	ND	1.1	2.1	<0.50	3.6	--	1.5	1.2	0.84	<2.0
Duplicate	04/14/10	ND	1.1	2.1	<0.50	3.7	--	1.5	1.1	<0.25	<2.0	
	09/22/10	ND	<0.50	1.5	<0.50	3.2	--	1.3	1.5	<0.25	<2.0	
MW-205	03/08/07	ND	<0.5	<0.5	<0.5	<1.5	--	<0.048	0.18	<0.095	--	
	06/07/07	ND	<0.5	<0.5	<0.5	<1.5	--	<0.050	0.098	<0.100	<0.037	
	09/28/07	ND	<0.5	<0.5	<0.5	<1.5	--	<0.050	<0.081	<0.100	<0.047	
	11/27/07	ND	<0.5	<0.5	<0.5	<1.5	--	<0.050	0.120	0.560	<0.047	
	02/12/08	ND	<0.500	<0.500	<0.500	<1.00	--	<0.050	<0.248	0.529	<1.00	
	05/14/08	ND	<0.500	<0.500	<0.500	<1.00	--	<0.050	<0.238	<0.476	<1.00	
	09/03/08	ND	<0.500	<0.500	<0.500	<1.00	--	<0.050	<0.240	<0.481	<1.00	
	12/05/08	ND	<0.500	<0.500	<0.500	<1.00	--	<0.050	<0.236	<0.472	<1.00	
	02/17/09	ND	<0.500	<0.500	<0.500	<1.00	--	<0.050	<0.248	<0.495	<1.00	
	05/13/09	ND	<0.500	<0.500	<0.500	<1.00	--	<0.050	<0.245	<0.490	<1.00	
	09/11/09	ND	<0.500	<0.500	<0.500	<1.00	--	0.1	<0.248	<0.495	<2.0	
	04/14/10	ND	<0.50	<0.50	<0.50	<2.0	--	0.051	<0.12	<0.25	<2.0	
		09/22/10	ND	<0.50	<0.50	<0.50	<2.0	--	0.082	0.15	<0.25	<2.0
	MW-206	03/08/07	ND	<0.5	<0.5	<0.5	<1.5	--	<0.048	<0.075	<0.094	--
06/07/07		ND	<0.5	<0.5	<0.5	<1.5	--	<0.050	<0.076	<0.095	0.078	
09/27/07		ND	<0.5	<0.5	<0.5	<1.5	--	<0.050	<0.076	<0.095	<0.047	
11/27/07		ND	<0.5	<0.5	<0.5	<1.5	--	<0.050	<0.077	<0.096	<0.24	
02/12/08		ND	<0.500	<0.500	<0.500	<1.00	--	<0.050	<0.236	<0.472	<1.00	
05/13/08		ND	<0.500	<0.500	<0.500	<1.00	--	<0.050	<0.250	<0.505	<1.00	
09/04/08		ND	<0.500	<0.500	<0.500	<1.00	--	<0.050	<0.240	<0.481	<1.00	
Duplicate		09/04/08	ND	<0.500	<0.500	<0.500	<1.00	--	<0.050	<0.240	<0.481	<1.00
		12/04/08	ND	<0.500	<0.500	<0.500	<1.00	--	<0.050	<0.236	<0.472	<1.00
Duplicate		12/04/08	ND	<0.500	<0.500	<0.500	<1.00	--	<0.050	<0.236	<0.472	<1.00
		02/18/09	ND	<0.500	<0.500	<0.500	<1.00	--	<0.050	<0.278	<0.556	<1.00
		05/12/09	ND	<0.500	<0.500	<0.500	<1.00	--	<0.050	<0.278	<0.556	<1.00
		09/11/09	ND	<0.500	<0.500	<0.500	<1.00	--	<0.050	<0.248	<0.495	<2.0
		04/13/10	ND	<0.50	<0.50	<0.50	<2.0	--	<0.050	--	--	--
		04/14/10	ND	--	--	--	--	--	--	<0.12	<0.24	<2.0
		09/22/10	ND	<0.50	<0.50	<0.50	<2.0	--	<0.050	<0.12	<0.25	<2.0

Table 1
Summary of Groundwater Analytical Data
Total Petroleum Hydrocarbons

Former Unocal Seattle Marketing Terminal
3001 Elliott Avenue
Seattle, Washington

Monitoring Well ¹	Date Sampled	LNAPL ²	BTEX (EPA Method 8020 or 8021B) (µg/L)				TPH (EPA Method 418.1) (mg/L)	NWTPH-Gx (mg/L)	NWTPH-D Extended ³ (mg/L)		Dissolved Lead (EPA 6000/7000 Series Method) (µg/L)	
			B	T	E	X		Gasoline	Diesel	Heavy Oil		
								C ₇ - C ₁₂	C ₁₂ - C ₂₄	>C ₂₄		
Offsite Area RALs		No visible sheen	40	14,300	1,400	4,400	--	1	10	15	50	
Offsite Area (continued)												
MW-207 Duplicate	03/08/07	ND	<0.5	<0.5	0.9	<1.5	--	<0.048	0.12	<0.095	--	
	03/08/07	ND	<0.5	<0.5	1.1	<1.5	--	<0.048	0.15	<0.095	--	
	06/07/07	ND	<0.5	<0.5	<0.5	<1.5	--	<0.05	<0.077	<0.096	0.11	
	09/27/07	ND	<0.5	<0.5	<0.5	<1.5	--	<0.050	<0.081	<0.10	<0.47	
	11/27/07	ND	<0.5	<0.5	<0.5	<1.5	--	<0.050	<0.076	<0.095	<0.047	
	02/12/08	ND	<0.500	<0.500	<0.500	<1.00	--	<0.050	<0.248	<0.495	<1.00	
	05/13/08	ND	<0.500	<0.500	<0.500	<1.00	--	<0.050	<0.250	<0.500	<1.00	
	09/04/08	ND	<0.500	<0.500	<0.500	<1.00	--	<0.050	<0.238	<0.476	<1.00	
	12/03/08	ND	<0.500	<0.500	<0.500	<1.00	--	<0.050	<0.238	<0.476	<1.00	
	02/18/09	ND	<0.500	<0.500	<0.500	<1.00	--	<0.050	<0.248	<0.495	<1.00	
	09/11/09	ND	<0.500	<0.500	<0.500	<1.00	--	<0.050	<0.248	<0.495	<2.0	
	04/14/10	ND	<0.50	<0.50	<0.50	<2.0	--	<0.050	<0.12	<0.24	<2.0	
									<0.12	<0.24	<2.0	
	Duplicate	09/21/10	ND	<0.50	<0.50	<0.50	<2.0	--	<0.050			
		09/21/10	ND	<0.50	<0.50	<0.50	<2.0	--	0.092	<0.12	<0.25	<2.0
Equip Blank	10/01/08	--	--	--	--	--	--	<0.050	--	--	--	

Notes:

¹Monitoring well locations are shown in Figure 2.

²LNAPL = light nonaqueous phase liquid.

³For December 2000 through June 2002, samples were first analyzed without the sulfuric acid/silica gel cleanup procedure (first or only result). If analytes were detected, the sulfuric acid/silica gel cleanup procedure was performed (second result). For September 2002 and after, samples obtained from Upper Yard wells were analyzed without the sulfuric acid/silica gel cleanup procedure, and samples obtained from Elliott Avenue and Offsite Area wells were analyzed with the sulfuric acid/silica gel cleanup procedure.

⁴According to the laboratory, the sample chromatogram does not resemble the gasoline standard.

⁵According to the laboratory, sample contains diesel-range hydrocarbons that extend into the hydrocarbon range quantified as gasoline.

⁶Due to an error in the identification of two sets of samples, (MW-64 and Dup 121699), the results from the sampling date of 01/04/00 were not considered reliable. The 12/26/99 results were not reported by the laboratory and a resampling took place.

⁷Due to an extraction anomaly during the silica gel cleanup procedure, a second analytical result is not available for this sample.

⁸After review of field procedures and historic analytical results, the sample appears to have been cross-contaminated in the field or in the laboratory.

⁹BTEX and gasoline-range hydrocarbon analyses were completed outside of the recommended holding time. Results should be qualified as estimated.

¹⁰Samples were extracted 3 or 4 days after expiration of the recommended holding time.

¹¹Results should be considered bias low or estimated due to laboratory QA/QC exception.

¹²MW-30 was not sampled between July 1989 and September 1990 because of the presence of free product.

¹³Due to an extraction anomaly, the surrogate recoveries in the WTPH-D extended analyses were outside the established control limits and the results should be considered a low

¹⁴The 03/23/99 data for diesel-range hydrocarbons (20.8/14.6 mg/L) for MW-84 appeared anomalous due to field sample handling or laboratory analytical error. The well was resampled on 04/01/99.

¹⁵Due to a lab error, the sample extract evaporated before testing and was not analyzed with the silica gel cleanup.

¹⁶Due to the presence of an interferent near its retention time, the normal reporting limit was not attained for this compound. The presence of or concentration cannot be determined.

µg/L = micrograms per liter mg/L = milligrams per liter ND = not detected RAL = remedial action level -- = not tested

Shaded concentrations are greater than corresponding Remedial Action Levels. Bolded data are for the current reporting period.

Table 2
Summary of Groundwater Analytical Data
Polynuclear Aromatic Hydrocarbons

Former Unocal Seattle Marketing Terminal
3001 Elliott Avenue
Seattle, Washington

OFFSITE AREA		Carcinogenic PAHs ^{2,3} (µg/L)								Noncarcinogenic PAHs ² (µg/L)								
Monitoring Well ¹	Sample Date	Benzo(a)anthracene	Benzo(a)pyrene	Benzo(b)fluoranthene	Benzo(k)fluoranthene	Chrysene	Dibenzo(a,h)anthracene	Indeno(1,2,3-cd)pyrene	Total CPAHs ⁴	Acenaphthene	Acenaphthylene	Anthracene	Benzo(g,h,i)perylene	Fluoranthene	Fluorene	Naphthalene	Phenanthrene	Pyrene
RAL		0.03	0.03	0.03	0.03	0.03	0.03	0.03	NE	NE	NE	NE	NE	NE	NE	NE	NE	NE
MW-27	12/13/02	0.0282	<0.0100	<0.0100	<0.0100	<0.0100	<0.0100	<0.0100	0.0282	0.398	<0.100	<0.100	<0.100	0.149	<0.100	<0.100	<0.100	<0.100
	06/19/03	0.0639	<0.0100	<0.0100	<0.0100	<0.0100	0.0288	0.0232	0.1159	3.46	<0.100	0.226	<0.100	0.963	0.296	0.188	0.357	0.952
	12/03/03	0.0266	<0.0100	<0.0100	<0.0100	0.0195	<0.0100	<0.0100	0.0461	--	--	--	--	--	--	<0.100	--	--
	06/03/04	0.0357	<0.0100	<0.0100	<0.0100	0.0276	<0.0100	<0.0100	0.0633	2.66	<0.100	0.178	<0.100	0.962	0.348	0.821	0.299	0.826
	12/06/04	0.0286	<0.0100	<0.0100	<0.0100	0.0190	<0.0100	<0.0100	0.0476	1.57	<0.100	<0.100	<0.100	0.269	<0.100	<0.100	<0.100	0.488
	06/03/05	0.0709	0.0127	0.0157	0.0166	0.0440	<0.0100	<0.0100	0.1499	2.01	<0.100	<0.100	<0.100	0.995	<0.100	<0.100	<0.100	1.21
	12/01/05	0.0921	0.0576	0.0649	0.0393	0.0698	<0.0100	0.0444	0.3681	--	--	--	--	--	--	--	--	--
	03/08/07	<0.02	<0.02	<0.02	<0.009	<0.02	<0.02	<0.02	<0.129	--	--	--	--	--	--	--	--	--
MW-27R	09/26/07	<0.0098	<0.0098	<0.0098	<0.0098	<0.0098	<0.0098	<0.0098	<0.0098	--	--	--	--	--	--	0.079 ⁵	--	--
	11/27/07	<0.010	<0.010	<0.010	<0.010	<0.010	<0.010	<0.010	<0.010	--	--	--	--	--	--	0.19	--	--
MW-67	06/19/03	0.0769	0.0195	<0.0100	<0.0100	0.0278	0.0849	0.0730	0.2821	1.99	<0.100	0.242	<0.100	0.602	0.106	<0.100	0.229	0.549
	12/03/03	0.0284	0.0101	<0.0100	0.0106	0.0337	<0.0100	<0.0100	0.0828	--	--	--	--	--	--	0.133	--	--
	06/03/04	0.0362	<0.0100	<0.0100	0.0132	0.0389	<0.0100	<0.0100	0.0883	1.25	<0.100	0.152	<0.100	0.839	<0.100	<0.100	<0.100	0.763
	12/06/04	0.0273	<0.0100	<0.0100	<0.0100	0.0258	<0.0100	<0.0100	0.0531	0.930	<0.100	<0.100	<0.100	0.342	<0.100	<0.100	<0.100	0.519
	03/04/05	0.0293	0.01	0.01	0.01	0.0221	0.01	0.01	0.0514	0.793	<0.100	0.148	<0.100	0.518	<0.100	<0.100	<0.100	0.511
	06/03/05	0.0323	<0.0100	<0.0100	<0.0100	0.0262	<0.0100	<0.0100	0.0585	0.714	<0.100	<0.100	<0.100	0.816	<0.100	<0.100	<0.100	0.843
MW-76	12/13/02	0.0247	<0.0100	<0.0100	<0.0100	<0.0100	<0.0100	<0.0100	0.0247	<0.100	<0.100	<0.100	<0.100	<0.100	<0.100	<0.100	<0.100	<0.100
	06/19/03	0.0824	0.0262	<0.0100	<0.0100	0.0258	0.0718	0.0589	0.2651	0.484	<0.100	<0.100	<0.100	0.628	<0.100	<0.100	<0.100	0.342
	12/03/03	0.0194	<0.0100	0.0107	<0.0100	0.0172	<0.0100	<0.0100	0.0473	--	--	--	--	--	--	<0.100	--	--
	06/03/04	<0.0100	<0.0100	0.0104	<0.0100	0.0253	<0.0100	<0.0100	0.0357	<0.100	<0.100	<0.100	<0.100	<0.100	<0.100	<0.100	<0.100	<0.100
	12/06/04	<0.0100	<0.0100	<0.0100	<0.0100	<0.0100	<0.0100	<0.0100	<0.0100	<0.100	<0.100	<0.100	<0.100	<0.100	<0.100	<0.100	<0.100	<0.100
	06/03/05	0.0725	0.0528	0.0448	0.0452	0.0797	0.0142	0.0267	0.3359	<0.100	<0.100	<0.100	<0.100	0.482	<0.100	<0.100	<0.100	0.369

Table 2
Summary of Groundwater Analytical Data
Polynuclear Aromatic Hydrocarbons

Former Unocal Seattle Marketing Terminal
 3001 Elliott Avenue
 Seattle, Washington

OFFSITE AREA		Carcinogenic PAHs ^{2,3} (µg/L)								Noncarcinogenic PAHs ² (µg/L)								
Monitoring Well ¹	Sample Date	Benzo(a)anthracene	Benzo(a)pyrene	Benzo(b)fluoranthene	Benzo(k)fluoranthene	Chrysene	Dibenzo(a,h)anthracene	Indeno(1,2,3-cd)pyrene	Total CPAHs ⁴	Acenaphthene	Acenaphthylene	Anthracene	Benzo(g,h,i)perylene	Fluoranthene	Fluorene	Naphthalene	Phenanthrene	Pyrene
RAL		0.03	0.03	0.03	0.03	0.03	0.03	0.03	NE	NE	NE	NE	NE	NE	NE	NE	NE	NE
MW-200	06/07/07	<1	<1	<1	<1	<1	<1	<1	<7	22	<1	<1	<1	<1	6	31	1	<1
	07/06/07	0.01	<0.0095	<0.0095	<0.0095	<0.0095	<0.0095	<0.0095	0.01	20	<0.30	0.51	<0.0095	0.7	5	24	0.93	0.46
	09/26/07	0.011	<0.011	<0.011	<0.011	<0.011	<0.011	<0.011	0.011	--	--	--	--	--	--	24 ⁵	--	--
Duplicate	9/26/2007 ^D	0.011	<0.011	<0.011	<0.011	<0.011	<0.011	<0.011	0.011	--	--	--	--	--	--	22 ⁵	--	--
	11/28/07	0.012	<0.010	<0.010	<0.010	<0.010	<0.010	<0.010	0.012	--	--	--	--	--	--	31	--	--
	02/13/08	0.0126	<0.00990	<0.00990	<0.00990	0.0137	<0.00990	<0.00990	0.0263	--	--	--	--	--	--	--	--	--
	05/13/08	<0.0100	<0.0100	<0.0100	<0.0100	<0.0100	<0.0100	<0.0100	<0.0100	--	--	--	--	--	--	--	--	--
(Field-Filtered)	05/13/08	<0.0101	<0.0101	<0.0101	<0.0101	<0.0101	<0.0101	<0.0101	<0.0101	--	--	--	--	--	--	--	--	--
	09/03/08	<0.00943	<0.00943	<0.00943	<0.00943	<0.00943	<0.00943	<0.00943	<0.00943	--	--	--	--	--	--	--	--	--
(Field-Filtered)	09/03/08	<0.0476	<0.0476	<0.0476	<0.0476	<0.0476	<0.0476	<0.0476	<0.0476	--	--	--	--	--	--	--	--	--
	12/04/08	<0.00943	<0.00943	<0.00943	<0.00943	<0.00943	<0.00943	<0.00943	<0.00943	--	--	--	--	--	--	--	--	--
(Field-Filtered)	12/04/08	<0.00962	<0.00962	<0.00962	<0.00962	<0.00962	<0.00962	<0.00962	<0.00962	--	--	--	--	--	--	--	--	--
	02/18/09	<0.0100	<0.0100	<0.0100	<0.0100	<0.0100	<0.0100	<0.0100	<0.0100	--	--	--	--	--	--	--	--	--
(Field-Filtered)	02/18/09	<0.0100	<0.0100	<0.0100	<0.0100	<0.0100	<0.0100	<0.0100	<0.0100	--	--	--	--	--	--	--	--	--
	05/13/09	<0.0111	<0.0111	<0.0111	<0.0111	<0.0111	<0.0111	<0.0111	<0.0111	--	--	--	--	--	--	--	--	--
(Field-Filtered)	05/13/09	<0.0111	<0.0111	<0.0111	<0.0111	<0.0111	<0.0111	<0.0111	<0.0111	--	--	--	--	--	--	--	--	--
	09/11/09	<0.0111	<0.0220	<0.0111	<0.0111	<0.0111	<0.0111	<0.0111	<0.0220	--	--	--	--	--	--	--	--	--
(Field-Filtered)	09/11/09	<0.0111	<0.0111	<0.0111	<0.0111	<0.0111	<0.0111	<0.0111	<0.0111	--	--	--	--	--	--	--	--	--
	04/14/10	<0.0099	<0.020	<0.0099	<0.0099	<0.0099	<0.0099	<0.0099	<0.020	--	--	--	--	--	--	--	--	--
(Field-Filtered)	04/14/10	<0.0099	<0.020	<0.0099	<0.0099	<0.0099	<0.0099	<0.0099	<0.020	--	--	--	--	--	--	--	--	--
	09/22/10	0.013	<0.010	<0.010	<0.010	<0.010	<0.010	<0.010	0.013	--	--	--	--	--	--	--	--	--
(Field-Filtered)	09/22/10	<0.0099	<0.020	<0.0099	<0.0099	<0.0099	<0.0099	<0.0099	<0.020	--	--	--	--	--	--	--	--	--

Table 2
Summary of Groundwater Analytical Data
Polynuclear Aromatic Hydrocarbons

Former Unocal Seattle Marketing Terminal
3001 Elliott Avenue
Seattle, Washington

OFFSITE AREA		Carcinogenic PAHs ^{2,3} (µg/L)								Noncarcinogenic PAHs ² (µg/L)								
Monitoring Well ¹	Sample Date	Benzo(a)anthracene	Benzo(a)pyrene	Benzo(b)fluoranthene	Benzo(k)fluoranthene	Chrysene	Dibenzo(a,h)anthracene	Indeno(1,2,3-cd)pyrene	Total CPAHs ⁴	Acenaphthene	Acenaphthylene	Anthracene	Benzo(g,h,i)perylene	Fluoranthene	Fluorene	Naphthalene	Phenanthrene	Pyrene
RAL		0.03	0.03	0.03	0.03	0.03	0.03	0.03	NE	NE	NE	NE	NE	NE	NE	NE	NE	NE
MW-201	06/07/07	<1	<1	<1	<1	<1	<1	<1	<1	6	<1	<1	<1	<1	2	1	<1	<1
	07/06/07	0.027	0.014	0.017	<0.0096	0.02	<0.0096	<0.0096	0.078	6.7	<0.10	0.52	<0.0096	0.83	2	2.6	0.3	0.72
	09/27/07	0.018	<0.011	<0.011	<0.011	0.027	<0.011	<0.011	0.045	--	--	--	--	--	--	2.3 ⁵	--	--
	11/27/07	0.016	<0.0095	<0.0095	<0.0095	0.023	<0.0095	<0.0095	0.039	--	--	--	--	--	--	0.99	--	--
	02/12/08	0.0179	0.0584	<0.0490	<0.0490	0.0210	<0.00980	<0.00980	0.0973	--	--	--	--	--	--	--	--	--
	05/14/08	0.051	<0.0472	<0.0472	<0.0472	0.0756	<0.0472	<0.0472	0.1266	--	--	--	--	--	--	--	--	--
(Field-Filtered)	05/14/08	<0.00952	<0.00952	<0.00952	<0.00952	<0.00952	<0.00952	<0.00952	<0.00952	--	--	--	--	--	--	--	--	--
	09/05/08	0.0243	<0.00962	<0.00962	<0.00962	0.0175	<0.00962	<0.00962	0.0418	--	--	--	--	--	--	--	--	--
(Field-Filtered)	09/05/08	<0.00962	<0.00962	<0.00962	<0.00962	<0.00962	<0.00962	<0.00962	<0.00962	--	--	--	--	--	--	--	--	--
	12/05/08	0.0247	<0.00980	<0.00980	<0.00980	0.0268	<0.00980	<0.00980	0.0515	--	--	--	--	--	--	--	--	--
(Field-Filtered)	12/05/08	<0.00971	<0.00971	<0.00971	<0.00971	<0.00971	<0.00971	<0.00971	<0.00971	--	--	--	--	--	--	--	--	--
	02/17/09	<0.00990	<0.00990	<0.00990	<0.00990	<0.00990	<0.00990	<0.00990	<0.00990	--	--	--	--	--	--	--	--	--
(Field-Filtered)	02/17/09	<0.0105	<0.0105	<0.0105	<0.0105	<0.0105	<0.0105	<0.0105	<0.0105	--	--	--	--	--	--	--	--	--
	05/13/09	0.0129	<0.0100	<0.0100	<0.0100	0.0191	<0.0100	<0.0100	0.0320	--	--	--	--	--	--	--	--	--
(Field-Filtered)	05/13/09	<0.0111	<0.0111	<0.0111	<0.0111	<0.0111	<0.0111	<0.0111	<0.0111	--	--	--	--	--	--	--	--	--
	09/11/09	0.021	<0.0200	<0.0100	<0.0100	0.025	<0.0100	<0.0100	0.0460	--	--	--	--	--	--	--	--	--
(Field-Filtered)	09/11/09	<0.0100	<0.0220	<0.0100	<0.0100	<0.0100	<0.0100	<0.0100	<0.0220	--	--	--	--	--	--	--	--	--
	04/14/10	0.014	<0.020	<0.0099	<0.0099	0.019	<0.0099	<0.0099	0.033	--	--	--	--	--	--	--	--	--
(Field-Filtered)	04/14/10	<0.0099	<0.020	<0.0099	<0.0099	<0.0099	<0.0099	<0.0099	<0.020	--	--	--	--	--	--	--	--	--
	09/22/10	0.026	<0.020	<0.0099	<0.0099	0.030	<0.0099	<0.0099	0.056	--	--	--	--	--	--	--	--	--
(Field-Filtered)	09/22/10	<0.0098	<0.020	<0.0098	<0.0098	<0.0098	<0.0098	<0.0098	<0.020	--	--	--	--	--	--	--	--	--

Table 2
Summary of Groundwater Analytical Data
Polynuclear Aromatic Hydrocarbons

Former Unocal Seattle Marketing Terminal
 3001 Elliott Avenue
 Seattle, Washington

OFFSITE AREA		Carcinogenic PAHs ^{2,3} (µg/L)								Noncarcinogenic PAHs ² (µg/L)								
Monitoring Well ¹	Sample Date	Benzo(a)anthracene	Benzo(a)pyrene	Benzo(b)fluoranthene	Benzo(k)fluoranthene	Chrysene	Dibenzo(a,h)anthracene	Indeno(1,2,3-cd)pyrene	Total CPAHs ⁴	Acenaphthene	Acenaphthylene	Anthracene	Benzo(g,h,i)perylene	Fluoranthene	Fluorene	Naphthalene	Phenanthrene	Pyrene
RAL		0.03	0.03	0.03	0.03	0.03	0.03	0.03	NE	NE	NE	NE	NE	NE	NE	NE	NE	NE
MW-202	06/07/07	<1	<1	<1	<1	<1	<1	<1	<7	2	<1	<1	<1	1	<1	<1	2	1
	07/06/07	0.05	0.014	0.016	<0.0097	0.049	<0.0097	<0.0097	0.129	0.27	<0.025	0.22	<0.0097	0.66	0.073	0.27	0.15	0.53
	09/27/07	0.042	<0.010	<0.010	<0.010	0.040	<0.010	<0.010	0.082	--	--	--	--	--	--	0.18 ⁵	--	--
	11/26/07	0.043	<0.010	<0.010	<0.010	0.036	<0.010	<0.010	0.079	--	--	--	--	--	--	<0.010	--	--
(Field-Filtered)	11/26/07	<0.011	<0.011	<0.011	<0.011	<0.011	<0.011	<0.011	<0.011	--	--	--	--	--	--	0.057	--	--
	02/12/08	0.0457	<0.00990	<0.00990	0.0184	0.0444	<0.00990	<0.00990	0.1085	--	--	--	--	--	--	--	--	--
(Field-Filtered)	02/12/08	<0.00980	<0.00980	<0.00980	<0.00980	<0.00980	<0.00980	<0.00980	<0.00980	--	--	--	--	--	--	--	--	--
	05/13/08	0.0406	<0.00943	0.0116	0.0149	0.0432	<0.00943	<0.00943	0.1103	--	--	--	--	--	--	--	--	--
(Field-Filtered)	05/13/08	<0.0101	<0.0101	<0.0101	<0.0101	<0.0101	<0.0101	<0.0101	<0.0101	--	--	--	--	--	--	--	--	--
	09/04/08	0.0502	<0.00962	<0.00962	<0.00962	0.0482	<0.00962	<0.00962	0.0984	--	--	--	--	--	--	--	--	--
(Field-Filtered)	09/04/08	<0.00971	<0.00971	<0.00971	<0.00971	<0.00971	<0.00971	<0.00971	<0.00971	--	--	--	--	--	--	--	--	--
	12/04/08	0.0286	<0.0100	<0.0100	<0.0100	0.0308	<0.0100	<0.0100	0.0594	--	--	--	--	--	--	--	--	--
(Field-Filtered)	12/04/08	<0.0100	<0.0100	<0.0100	<0.0100	<0.0100	<0.0100	<0.0100	<0.0100	--	--	--	--	--	--	--	--	--
	02/18/09	0.0181	<0.00980	<0.00980	<0.00980	0.0222	<0.00980	<0.00980	0.0403	--	--	--	--	--	--	--	--	--
(Field-Filtered)	02/18/09	<0.0100	<0.0100	<0.0100	<0.0100	<0.0100	<0.0100	<0.0100	<0.0100	--	--	--	--	--	--	--	--	--
	05/13/09	0.0146	<0.00943	<0.00943	<0.00943	0.0160	<0.00943	<0.00943	0.0306	--	--	--	--	--	--	--	--	--
(Field-Filtered)	05/13/09	<0.00952	<0.00952	<0.00952	<0.00952	<0.00952	<0.00952	<0.00952	<0.00952	--	--	--	--	--	--	--	--	--
	09/11/09	0.0490	<0.0200	0.0110	<0.0100	0.0470	<0.0100	<0.0100	0.1070	--	--	--	--	--	--	--	--	--
(Field-Filtered)	09/11/09	<0.0100	<0.0200	<0.0100	<0.0100	<0.0100	<0.0100	<0.0100	<0.0200	--	--	--	--	--	--	--	--	--
	04/14/10	0.013	<0.020	<0.0099	<0.0099	0.013	<0.0099	<0.0099	0.026	--	--	--	--	--	--	--	--	--
(Field-Filtered)	04/14/10	<0.0099	<0.020	<0.0099	<0.0099	<0.0099	<0.0099	<0.0099	<0.020	--	--	--	--	--	--	--	--	--
	09/22/10	0.041	<0.020	0.012	<0.010	0.043	<0.010	<0.010	0.096	--	--	--	--	--	--	--	--	--
(Field-Filtered)	09/22/10	<0.0095	<0.019	<0.0095	<0.0095	<0.0095	<0.0095	<0.0095	<0.019	--	--	--	--	--	--	--	--	--

Table 2
Summary of Groundwater Analytical Data
Polynuclear Aromatic Hydrocarbons

Former Unocal Seattle Marketing Terminal
 3001 Elliott Avenue
 Seattle, Washington

OFFSITE AREA		Carcinogenic PAHs ^{2,3} (µg/L)								Noncarcinogenic PAHs ² (µg/L)								
Monitoring Well ¹	Sample Date	Benzo(a)anthracene	Benzo(a)pyrene	Benzo(b)fluoranthene	Benzo(k)fluoranthene	Chrysene	Dibenzo(a,h)anthracene	Indeno(1,2,3-cd)pyrene	Total CPAHs ⁴	Acenaphthene	Acenaphthylene	Anthracene	Benzo(g,h,i)perylene	Fluoranthene	Fluorene	Naphthalene	Phenanthrene	Pyrene
RAL		0.03	0.03	0.03	0.03	0.03	0.03	0.03	NE	NE	NE	NE	NE	NE	NE	NE	NE	NE
MW-203	06/07/07	<1	<1	<1	<1	<1	<1	<1	<1	<1	<1	<1	<1	<1	<1	<1	<1	<1
	07/06/07	<0.0096	<0.0096	<0.0096	<0.0096	<0.0096	<0.0096	<0.0096	<0.0096	0.62	<0.0096	0.12	<0.0096	0.16	0.047	0.052	0.013	0.11
	09/28/07	<0.010	<0.010	<0.010	<0.010	<0.010	<0.010	<0.010	<0.07	-	-	-	-	-	-	0.13	-	-
	11/27/07	<0.010	<0.010	<0.010	<0.010	<0.010	<0.010	<0.010	<0.010	-	-	-	-	-	-	<0.010	-	-
	02/12/08	0.0127	<0.00980	<0.00980	<0.00980	<0.00980	<0.00980	<0.00980	0.0127	-	-	-	-	-	-	-	-	-
Duplicate	02/12/08	<0.00971	<0.00971	<0.00971	<0.00971	<0.00971	<0.00971	<0.00971	<0.00971	-	-	-	-	-	-	-	-	-
	05/14/08	<0.00971	<0.00971	<0.00971	<0.00971	<0.00971	<0.00971	<0.00971	<0.00971	-	-	-	-	-	-	-	-	-
(Field-Filtered)	05/14/08	<0.00962	<0.00962	<0.00962	<0.00962	<0.00962	<0.00962	<0.00962	<0.00962	-	-	-	-	-	-	-	-	-
	09/03/08	<0.00952	<0.00952	<0.00952	<0.00952	<0.00952	<0.00952	<0.00952	<0.00952	-	-	-	-	-	-	-	-	-
(Field-Filtered)	09/03/08	<0.00962	<0.00962	<0.00962	<0.00962	<0.00962	<0.00962	<0.00962	<0.00962	-	-	-	-	-	-	-	-	-
	12/04/08	<0.00952	<0.00952	<0.00952	<0.00952	<0.00952	<0.00952	<0.00952	<0.00952	-	-	-	-	-	-	-	-	-
(Field-Filtered)	12/04/08	<0.00952	<0.00952	<0.00952	<0.00952	<0.00952	<0.00952	<0.00952	<0.00952	-	-	-	-	-	-	-	-	-
	02/17/09	<0.00990	<0.00990	<0.00990	<0.00990	<0.00990	<0.00990	<0.00990	<0.00990	-	-	-	-	-	-	-	-	-
(Field-Filtered)	02/17/09	<0.00990	<0.00990	<0.00990	<0.00990	<0.00990	<0.00990	<0.00990	<0.00990	-	-	-	-	-	-	-	-	-
	05/13/09	<0.00943	<0.00943	<0.00943	<0.00943	<0.00943	<0.00943	<0.00943	<0.00943	-	-	-	-	-	-	-	-	-
(Field-Filtered)	05/13/09	<0.00990	<0.00990	<0.00990	<0.00990	<0.00990	<0.00990	<0.00990	<0.00990	-	-	-	-	-	-	-	-	-
	09/11/09	<0.0110	<0.0220	<0.0110	<0.0110	<0.0110	<0.0110	<0.0110	<0.0220	-	-	-	-	-	-	-	-	-
(Field-Filtered)	09/11/09	<0.0110	<0.0220	<0.0110	<0.0110	<0.0110	<0.0110	<0.0110	<0.0220	-	-	-	-	-	-	-	-	-
	04/14/10	<0.010	<0.020	<0.010	<0.010	<0.010	<0.010	<0.010	<0.020	-	-	-	-	-	-	-	-	-
(Field-Filtered)	04/14/10	<0.0097	<0.019	<0.0097	<0.0097	<0.0097	<0.0097	<0.0097	<0.019	-	-	-	-	-	-	-	-	-
	09/22/10	<0.010	<0.020	<0.010	<0.010	<0.010	<0.010	<0.010	<0.020	-	-	-	-	-	-	-	-	-
(Field-Filtered)	09/22/10	<0.010	<0.020	<0.010	<0.010	<0.010	<0.010	<0.010	<0.010	-	-	-	-	-	-	-	-	-

Table 2
Summary of Groundwater Analytical Data
Polynuclear Aromatic Hydrocarbons

Former Unocal Seattle Marketing Terminal
 3001 Elliott Avenue
 Seattle, Washington

OFFSITE AREA		Carcinogenic PAHs ^{2,3} (µg/L)								Noncarcinogenic PAHs ² (µg/L)								
Monitoring Well ¹	Sample Date	Benzo(a)anthracene	Benzo(a)pyrene	Benzo(b)fluoranthene	Benzo(k)fluoranthene	Chrysene	Dibenzo(a,h)anthracene	Indeno(1,2,3-cd)pyrene	Total CPAHs ⁴	Acenaphthene	Acenaphthylene	Anthracene	Benzo(g,h,i)perylene	Fluoranthene	Fluorene	Naphthalene	Phenanthrene	Pyrene
RAL		0.03	0.03	0.03	0.03	0.03	0.03	0.03	NE	NE	NE	NE	NE	NE	NE	NE	NE	NE
MW-204	06/07/07	<1	<1	<1	<1	<1	<1	<1	<7	5	<1	<1	<1	<1	3	<1	<1	<1
	07/06/07	<0.0095	<0.0095	<0.0095	<0.0095	<0.0095	<0.0095	<0.0095	<0.0095	3.3	<0.30	0.19	<0.0095	0.06	2.7	0.45	1.1	0.061
Duplicate	7/6/2007 ^D	<0.0096	<0.0096	<0.0096	<0.0096	<0.0096	<0.0096	<0.0096	<0.0096	3.3	<0.30	0.18	<0.0096	0.058	2.7	0.44	1	0.064
	09/28/07	0.010	<0.010	<0.010	<0.010	<0.010	<0.010	<0.010	0.010	--	--	--	--	--	--	0.84	--	--
	11/27/07	<0.010	<0.010	<0.010	<0.010	<0.010	<0.010	<0.010	<0.010	--	--	--	--	--	--	<0.010	--	--
	02/12/08	<0.00971	<0.00971	<0.00971	<0.00971	<0.00971	<0.00971	<0.00971	<0.00971	--	--	--	--	--	--	--	--	--
	05/14/08	<0.0100	<0.0100	<0.0100	<0.0100	<0.0100	<0.0100	<0.0100	<0.0100	--	--	--	--	--	--	--	--	--
(Field-Filtered)	05/14/08	<0.0100	<0.0100	<0.0100	<0.0100	<0.0100	<0.0100	<0.0100	<0.0100	--	--	--	--	--	--	--	--	--
(Field-Filtered)	09/03/08	<0.00962	<0.00962	<0.00962	<0.00962	<0.00962	<0.00962	<0.00962	<0.00962	--	--	--	--	--	--	--	--	--
(Field-Filtered)	09/03/08	<0.00962	<0.00962	<0.00962	<0.00962	<0.00962	<0.00962	<0.00962	<0.00962	--	--	--	--	--	--	--	--	--
(Field-Filtered)	12/04/08	<0.00980	<0.00980	<0.00980	<0.00980	<0.00980	<0.00980	<0.00980	<0.00980	--	--	--	--	--	--	--	--	--
(Field-Filtered)	12/04/08	<0.00990	<0.00990	<0.00990	<0.00990	<0.00990	<0.00990	<0.00990	<0.00990	--	--	--	--	--	--	--	--	--
	02/17/09	<0.0105	<0.0105	<0.0105	<0.0105	<0.0105	<0.0105	<0.0105	<0.0105	--	--	--	--	--	--	--	--	--
Duplicate	02/17/09	<0.0105	<0.0105	<0.0105	<0.0105	<0.0105	<0.0105	<0.0105	<0.0105	--	--	--	--	--	--	--	--	--
(Field-Filtered)	02/17/09	<0.0100	<0.0100	<0.0100	<0.0100	<0.0100	<0.0100	<0.0100	<0.0100	--	--	--	--	--	--	--	--	--
Duplicate	02/17/09	<0.0100	<0.0100	<0.0100	<0.0100	<0.0100	<0.0100	<0.0100	<0.0100	--	--	--	--	--	--	--	--	--
	05/13/09	<0.0100	<0.0100	<0.0100	<0.0100	0.0193	<0.0100	<0.0100	0.0193	--	--	--	--	--	--	--	--	--
Duplicate	05/13/09	<0.0100	<0.0100	<0.0100	<0.0100	<0.0100	<0.0100	<0.0100	<0.0100	--	--	--	--	--	--	--	--	--
(Field-Filtered)	05/13/09	<0.0100	<0.0100	<0.0100	<0.0100	<0.0100	<0.0100	<0.0100	<0.0100	--	--	--	--	--	--	--	--	--
Duplicate	05/13/09	<0.0100	<0.0100	<0.0100	<0.0100	<0.0100	<0.0100	<0.0100	<0.0100	--	--	--	--	--	--	--	--	--
	09/11/09	<0.0100	<0.0200	<0.0100	<0.0100	<0.0100	<0.0100	<0.0100	<0.0200	--	--	--	--	--	--	--	--	--
Duplicate	09/11/09	<0.0100	<0.0200	<0.0100	<0.0100	<0.0100	<0.0100	<0.0100	<0.0200	--	--	--	--	--	--	--	--	--
(Field-Filtered)	09/11/09	<0.0110	<0.0220	<0.0110	<0.0110	<0.0110	<0.0110	<0.0110	<0.0220	--	--	--	--	--	--	--	--	--
Duplicate	09/11/09	<0.0096	<0.0190	<0.0096	<0.0096	<0.0096	<0.0096	<0.0096	<0.0190	--	--	--	--	--	--	--	--	--
	04/14/10	<0.0097	<0.019	<0.0097	<0.0097	<0.0097	<0.0097	<0.0097	<0.019	--	--	--	--	--	--	--	--	--
Duplicate	04/14/10	<0.0099	<0.020	<0.0099	<0.0099	0.0099	<0.0099	<0.0099	0.0099	--	--	--	--	--	--	--	--	--
(Field-Filtered)	04/14/10	<0.010	<0.020	<0.010	<0.010	<0.010	<0.010	<0.010	<0.020	--	--	--	--	--	--	--	--	--
Duplicate	04/14/10	<0.0099	<0.020	<0.0099	<0.0099	<0.0099	<0.0099	<0.0099	<0.020	--	--	--	--	--	--	--	--	--
	09/22/10	<0.010	<0.020	<0.010	<0.010	<0.010	<0.010	<0.010	<0.020	--	--	--	--	--	--	--	--	--
(Field-Filtered)	09/22/10	<0.010	<0.020	<0.010	<0.010	<0.010	<0.010	<0.010	<0.020	--	--	--	--	--	--	--	--	--
MW-205	06/07/07	<1	<1	<1	<1	<1	<1	<1	<1	4	<1	<1	<1	<1	<1	<1	<1	<1

Table 2
Summary of Groundwater Analytical Data
Polynuclear Aromatic Hydrocarbons

Former Unocal Seattle Marketing Terminal
 3001 Elliott Avenue
 Seattle, Washington

OFFSITE AREA		Carcinogenic PAHs ^{2,3} (µg/L)								Noncarcinogenic PAHs ² (µg/L)								
Monitoring Well ¹	Sample Date	Benzo(a)anthracene	Benzo(a)pyrene	Benzo(b)fluoranthene	Benzo(k)fluoranthene	Chrysene	Dibenzo(a,h)anthracene	Indeno(1,2,3-cd)pyrene	Total CPAHs ⁴	Acenaphthene	Acenaphthylene	Anthracene	Benzo(g,h,i)perylene	Fluoranthene	Fluorene	Naphthalene	Phenanthrene	Pyrene
RAL		0.03	0.03	0.03	0.03	0.03	0.03	0.03	NE	NE	NE	NE	NE	NE	NE	NE	NE	NE
	07/06/07	<0.0096	<0.0096	<0.0096	<0.0096	<0.0096	<0.0096	<0.0096	<0.0096	3.4	0.022	<0.0096	<0.0096	<0.0096	<0.0096	0.041	<0.0096	0.01
	09/28/07	<0.010	<0.010	<0.010	<0.010	<0.010	<0.010	<0.010	<0.010	--	--	--	--	--	--	0.050	--	--
	11/27/07	<0.010	<0.010	<0.010	<0.010	<0.010	<0.010	<0.010	<0.010	--	--	--	--	--	--	0.022	--	--
	02/12/08	<0.0111	<0.0111	<0.0111	<0.0111	<0.0111	<0.0111	<0.0111	<0.0111	--	--	--	--	--	--	--	--	--
(Field-Filtered)	05/14/08	<0.00962	<0.00962	<0.00962	<0.00962	<0.00962	<0.00962	<0.00962	<0.00962	--	--	--	--	--	--	--	--	--
	05/14/08	<0.00952	<0.00952	<0.00952	<0.00952	<0.00952	<0.00952	<0.00952	<0.00952	--	--	--	--	--	--	--	--	--
(Field-Filtered)	09/03/08	<0.00943	<0.00943	<0.00943	<0.00943	<0.00943	<0.00943	<0.00943	<0.00943	--	--	--	--	--	--	--	--	--
	09/03/08	<0.00943	<0.00943	<0.00943	<0.00943	<0.00943	<0.00943	<0.00943	<0.00943	--	--	--	--	--	--	--	--	--
(Field-Filtered)	12/05/08	<0.00943	<0.00943	<0.00943	<0.00943	<0.00943	<0.00943	<0.00943	<0.00943	--	--	--	--	--	--	--	--	--
	12/05/08	<0.00943	<0.00943	<0.00943	<0.00943	<0.00943	<0.00943	<0.00943	<0.00943	--	--	--	--	--	--	--	--	--
(Field-Filtered)	02/17/09	<0.00990	<0.00990	<0.00990	<0.00990	<0.00990	<0.00990	<0.00990	<0.00990	--	--	--	--	--	--	--	--	--
	02/17/09	<0.00990	<0.00990	<0.00990	<0.00990	<0.00990	<0.00990	<0.00990	<0.00990	--	--	--	--	--	--	--	--	--
(Field-Filtered)	05/13/09	<0.0100	<0.0100	<0.0100	<0.0100	<0.0100	<0.0100	<0.0100	<0.0100	--	--	--	--	--	--	--	--	--
	05/13/09	<0.0100	<0.0100	<0.0100	<0.0100	<0.0100	<0.0100	<0.0100	<0.0100	--	--	--	--	--	--	--	--	--
(Field-Filtered)	09/11/09	<0.0110	<0.0220	<0.0110	<0.0110	<0.0110	<0.0110	<0.0110	<0.0220	--	--	--	--	--	--	--	--	--
	09/11/09	<0.0110	<0.0220	<0.0110	<0.0110	<0.0110	<0.0110	<0.0110	<0.0220	--	--	--	--	--	--	--	--	--
(Field-Filtered)	04/14/10	<0.013	<0.026	<0.013	<0.013	<0.013	<0.013	<0.013	<0.026	--	--	--	--	--	--	--	--	--
	04/14/10	<0.0095	<0.019	<0.0095	<0.0095	<0.0095	<0.0095	<0.0095	<0.019	--	--	--	--	--	--	--	--	--
(Field-Filtered)	09/22/10	<0.0094	<0.019	<0.0094	<0.0094	<0.0094	<0.0094	<0.0094	<0.019	--	--	--	--	--	--	--	--	--
	09/22/10	<0.0099	<0.020	<0.0099	<0.0099	<0.0099	<0.0099	<0.0099	<0.020	--	--	--	--	--	--	--	--	--
(Field-Filtered)																		

Table 2
Summary of Groundwater Analytical Data
Polynuclear Aromatic Hydrocarbons

Former Unocal Seattle Marketing Terminal
 3001 Elliott Avenue
 Seattle, Washington

OFFSITE AREA		Carcinogenic PAHs ^{2,3} (µg/L)								Noncarcinogenic PAHs ² (µg/L)								
Monitoring Well ¹	Sample Date	Benzo(a)anthracene	Benzo(a)pyrene	Benzo(b)fluoranthene	Benzo(k)fluoranthene	Chrysene	Dibenzo(a,h)anthracene	Indeno(1,2,3-cd)pyrene	Total CPAHs ⁴	Acenaphthene	Acenaphthylene	Anthracene	Benzo(g,h,i)perylene	Fluoranthene	Fluorene	Naphthalene	Phenanthrene	Pyrene
RAL		0.03	0.03	0.03	0.03	0.03	0.03	0.03	NE	NE	NE	NE	NE	NE	NE	NE	NE	NE
MW-206	06/07/07	<1	<1	<1	<1	<1	<1	<1	<1	<1	<1	<1	<1	<1	<1	<1	<1	<1
	07/06/07	<0.0096	<0.0096	<0.0096	<0.0096	<0.0096	<0.0096	<0.0096	<0.0096	1.9	<0.0096	0.069	<0.0096	0.087	0.14	0.19	0.51	0.036
	09/27/07	<0.010	<0.010	<0.010	<0.010	<0.010	<0.010	<0.010	<0.010	--	--	--	--	--	--	0.063 ⁵	--	--
	11/27/07	<0.010	<0.010	<0.010	<0.010	<0.010	<0.010	<0.010	<0.010	--	--	--	--	--	--	0.031	--	--
	02/12/08	<0.0100	<0.0100	<0.0100	<0.0100	<0.0100	<0.0100	<0.0100	<0.0100	--	--	--	--	--	--	--	--	--
	05/13/08	<0.00990	<0.00990	<0.00990	<0.00990	<0.00990	<0.00990	<0.00990	<0.00990	--	--	--	--	--	--	--	--	--
(Field-Filtered)	05/13/08	<0.00943	<0.00943	<0.00943	<0.00943	<0.00943	<0.00943	<0.00943	<0.00943	--	--	--	--	--	--	--	--	--
	09/04/08	<0.00943	<0.00943	<0.00943	<0.00943	<0.00943	<0.00943	<0.00943	<0.00943	--	--	--	--	--	--	--	--	--
Duplicate ⁶	09/04/08	<0.0100	<0.0100	<0.0100	<0.0100	<0.0100	<0.0100	<0.0100	<0.0100	--	--	--	--	--	--	--	--	--
(Field-Filtered)	09/04/08	0.0132	<0.00952	<0.00952	0.0107	0.0134	0.0638	0.0125	0.1136	--	--	--	--	--	--	--	--	--
Duplicate	09/04/08	<0.00952	<0.00952	<0.00952	<0.00952	<0.00952	<0.00952	<0.00952	<0.00952	--	--	--	--	--	--	--	--	--
	10/01/08	<0.0102	<0.0102	<0.0102	<0.0102	<0.0102	<0.0102	<0.0102	<0.0102	--	--	--	--	--	--	--	--	--
(Field-Filtered)	10/01/08	<0.0101	<0.0101	<0.0101	<0.0101	<0.0101	<0.0101	<0.0101	<0.0101	--	--	--	--	--	--	--	--	--
	12/04/08	<0.00952	<0.00952	<0.00952	<0.00952	<0.00952	<0.00952	<0.00952	<0.00952	--	--	--	--	--	--	--	--	--
(Field-Filtered)	12/04/08	<0.00943	<0.00943	<0.00943	<0.00943	<0.00943	<0.00943	<0.00943	<0.00943	--	--	--	--	--	--	--	--	--
Duplicate	12/04/08	<0.00962	<0.00962	<0.00962	<0.00962	<0.00962	<0.00962	<0.00962	<0.00962	--	--	--	--	--	--	--	--	--
(Field-Filtered)	12/04/08	<0.00980	<0.00980	<0.00980	<0.00980	<0.00980	<0.00980	<0.00980	<0.00980	--	--	--	--	--	--	--	--	--
	02/18/09	<0.0100	<0.0100	<0.0100	<0.0100	<0.0100	<0.0100	<0.0100	<0.0100	--	--	--	--	--	--	--	--	--
(Field-Filtered)	02/18/09	<0.0100	<0.0100	<0.0100	<0.0100	<0.0100	<0.0100	<0.0100	<0.0100	--	--	--	--	--	--	--	--	--
	05/12/09	<0.0100	<0.0100	<0.0100	<0.0100	<0.0100	<0.0100	<0.0100	<0.0100	--	--	--	--	--	--	--	--	--
(Field-Filtered)	05/12/09	<0.0125	<0.0125	<0.0125	<0.0125	<0.0125	<0.0125	<0.0125	<0.0125	--	--	--	--	--	--	--	--	--
	09/11/09	<0.0100	<0.0200	<0.0100	<0.0100	<0.0100	<0.0100	<0.0100	<0.0100	--	--	--	--	--	--	--	--	--
(Field-Filtered)	09/11/09	<0.0110	<0.0220	<0.0110	<0.0110	<0.0110	<0.0110	<0.0110	<0.0110	--	--	--	--	--	--	--	--	--
	04/14/10	<0.010	<0.020	<0.010	<0.010	<0.010	<0.010	<0.010	<0.020	--	--	--	--	--	--	--	--	--
(Field-Filtered)	04/14/10	<0.0098	<0.020	<0.0098	<0.0098	<0.0098	<0.0098	<0.0098	<0.020	--	--	--	--	--	--	--	--	--
	09/22/10	<0.0095	<0.019	<0.0095	<0.0095	<0.0095	<0.0095	<0.0095	<0.019	--	--	--	--	--	--	--	--	--
(Field-Filtered)	09/22/10	<0.0099	<0.020	<0.0099	<0.0099	<0.0099	<0.0099	<0.0099	<0.020	--	--	--	--	--	--	--	--	--

Table 2
Summary of Groundwater Analytical Data
Polynuclear Aromatic Hydrocarbons

Former Unocal Seattle Marketing Terminal
 3001 Elliott Avenue
 Seattle, Washington

OFFSITE AREA		Carcinogenic PAHs ^{2,3} (µg/L)							Noncarcinogenic PAHs ² (µg/L)									
Monitoring Well ¹	Sample Date	Benzo(a)anthracene	Benzo(a)pyrene	Benzo(b)fluoranthene	Benzo(k)fluoranthene	Chrysene	Dibenzo(a,h)anthracene	Indeno(1,2,3-cd)pyrene	Total CPAHs ⁴	Acenaphthene	Acenaphthylene	Anthracene	Benzo(g,h,i)perylene	Fluoranthene	Fluorene	Naphthalene	Phenanthrene	Pyrene
RAL		0.03	0.03	0.03	0.03	0.03	0.03	0.03	NE	NE	NE	NE	NE	NE	NE	NE	NE	NE
MW-207	06/07/07	<1	<1	<1	<1	<1	<1	<1	<1	2	<1	<1	<1	<1	<1	<1	<1	<1
	07/06/07	<0.0096	<0.0096	<0.0096	<0.0096	<0.0096	<0.0096	<0.0096	<0.0096	0.31	<1	0.01	<0.0096	0.017	0.033	0.014	0.064	<0.0096
	09/27/07	<0.010	<0.010	<0.010	<0.010	<0.010	<0.010	<0.010	<0.010	--	--	--	--	--	--	<0.010	--	--
	11/27/07	<0.010	<0.010	<0.010	<0.010	<0.010	<0.010	<0.010	<0.010	--	--	--	--	--	--	<0.010	--	--
	02/12/08	<0.00990	<0.00990	<0.00990	<0.00990	<0.00990	<0.00990	<0.00990	<0.00990	--	--	--	--	--	--	--	--	--
	05/13/08	<0.0100	<0.0100	<0.0100	<0.0100	<0.0100	<0.0100	<0.0100	<0.0100	--	--	--	--	--	--	--	--	--
(Field-Filtered)	05/13/08	<0.0100	<0.0100	<0.0100	<0.0100	<0.0100	<0.0100	<0.0100	<0.0100	--	--	--	--	--	--	--	--	--
	09/04/08	<0.00943	<0.00943	<0.00943	<0.00943	<0.00943	<0.00943	<0.00943	<0.00943	--	--	--	--	--	--	--	--	--
(Field-Filtered)	09/04/08	<0.00952	<0.00952	0.0303	0.0256	<0.00952	<0.00952	<0.00952	0.0559	--	--	--	--	--	--	--	--	--
	10/01/08	<0.00990	<0.00990	<0.00990	<0.00990	<0.00990	<0.00990	<0.00990	<0.00990	--	--	--	--	--	--	--	--	--
Duplicate	10/01/08	<0.0100	<0.0100	<0.0100	<0.0100	<0.0100	<0.0100	<0.0100	<0.0100	--	--	--	--	--	--	--	--	--
(Field-Filtered)	10/01/08	<0.0100	<0.0100	<0.0100	<0.0100	<0.0100	<0.0100	<0.0100	<0.0100	--	--	--	--	--	--	--	--	--
Duplicate	10/01/08	<0.0100	<0.0100	<0.0100	<0.0100	<0.0100	<0.0100	<0.0100	<0.0100	--	--	--	--	--	--	--	--	--
	12/03/08	<0.00952	<0.00952	<0.00952	<0.00952	<0.00952	<0.00952	<0.00952	<0.00952	--	--	--	--	--	--	--	--	--
(Field-Filtered)	12/03/08	<0.00943	<0.00943	<0.00943	<0.00943	<0.00943	<0.00943	<0.00943	<0.00943	--	--	--	--	--	--	--	--	--
	02/18/09	<0.00990	<0.00990	<0.00990	<0.00990	<0.00990	<0.00990	<0.00990	<0.00990	--	--	--	--	--	--	--	--	--
(Field-Filtered)	02/18/09	<0.00990	<0.00990	<0.00990	<0.00990	<0.00990	<0.00990	<0.00990	<0.00990	--	--	--	--	--	--	--	--	--
	05/12/09	<0.00980	<0.00980	<0.00980	<0.00980	<0.00980	<0.00980	<0.00980	<0.00980	--	--	--	--	--	--	--	--	--
(Field-Filtered)	05/12/09	<0.0100	<0.0100	<0.0100	<0.0100	<0.0100	<0.0100	<0.0100	<0.0100	--	--	--	--	--	--	--	--	--
	09/11/09	<0.0100	<0.0200	<0.0100	<0.0100	<0.0100	<0.0100	<0.0100	<0.0200	--	--	--	--	--	--	--	--	--
(Field-Filtered)	09/11/09	<0.0110	<0.0220	<0.0110	<0.0110	<0.0110	<0.0110	<0.0110	<0.0220	--	--	--	--	--	--	--	--	--
	04/14/10	<0.0097	<0.019	<0.0097	<0.0097	<0.0097	<0.0097	<0.0097	<0.019	--	--	--	--	--	--	--	--	--
(Field-Filtered)	04/14/10	<0.0094	<0.019	<0.0094	<0.0094	<0.0094	<0.0094	<0.0094	<0.019	--	--	--	--	--	--	--	--	--
	09/21/10	<0.0095	<0.019	<0.0095	<0.0095	<0.0095	<0.0095	<0.0095	<0.019	--	--	--	--	--	--	--	--	--
Duplicate	09/21/10	<0.0096	<0.019	<0.0096	<0.0096	<0.0096	<0.0096	<0.0096	<0.019	--	--	--	--	--	--	--	--	--
(Field-Filtered)	09/21/10	<0.0094	<0.019	<0.0094	<0.0094	<0.0094	<0.0094	<0.0094	<0.019	--	--	--	--	--	--	--	--	--
Duplicate	09/21/10	<0.010	<0.020	<0.010	<0.010	<0.010	<0.010	<0.010	<0.020	--	--	--	--	--	--	--	--	--
Filter Blank	10/01/08	<0.0103	<0.0103	<0.0103	<0.0103	<0.0103	<0.0103	<0.0103	<0.0103	--	--	--	--	--	--	--	--	--
(Field-Filtered)	10/01/08	<0.0100	<0.0100	<0.0100	<0.0100	<0.0100	<0.0100	<0.0100	<0.0100	--	--	--	--	--	--	--	--	--

Table 2
Summary of Groundwater Analytical Data
Polynuclear Aromatic Hydrocarbons

Former Unocal Seattle Marketing Terminal
 3001 Elliott Avenue
 Seattle, Washington

OFFSITE AREA		Carcinogenic PAHs ^{2,3} (µg/L)								Noncarcinogenic PAHs ² (µg/L)								
Monitoring Well ¹	Sample Date	Benzo(a)anthracene	Benzo(a)pyrene	Benzo(b)fluoranthene	Benzo(k)fluoranthene	Chrysene	Dibenzo(a,h)anthracene	Indeno(1,2,3-cd)pyrene	Total CPAHs ⁴	Acenaphthene	Acenaphthylene	Anthracene	Benzo(g,h,i)perylene	Fluoranthene	Fluorene	Naphthalene	Phenanthrene	Pyrene
RAL		0.03	0.03	0.03	0.03	0.03	0.03	0.03	NE	NE	NE	NE	NE	NE	NE	NE	NE	NE

Notes:

¹Monitoring well locations shown on Figure 2.

²Analyses by EPA Method 8310 or 8270 (SIM).

³WAC 173-340-200 (MTCA).

⁴Numeric sum of detected concentrations of CPAHs. Where no CPAH compounds were detected, this figure is equal to the highest reporting limit for an individual compound.

⁵Naphthalene detected in the method blank, these data are from the initial extraction of the sample.

⁶Sample was extracted past the holding time.

^DDuplicate of the preceding sample.

RAL = Remedial Action Level per Amendments No. 4 and No. 5 to Order on Consent; applicable for Offsite Area only.

There is no CPAH RAL for groundwater in the Upper Yard, Lower Yard or Elliott Avenue.

µg/L = micrograms per liter

NE = not established

"--" not sampled

PAHs = polynuclear aromatic hydrocarbons.

Laboratory analyses by TestAmerica of Tacoma, Washington and Lancaster Laboratories of Lancaster, Pennsylvania.

Bolded data are for the current reporting period.

Shading indicates concentration greater than the RAL.

Table 3

Monitoring Well History
Former Unocal Seattle Marketing Terminal
3001 Elliott Avenue
Seattle, Washington

Well ID	Installation Date	Compliance Parameters	Compliance/Removal Date
Upper Yard			
MW-37	06/1990	LNAPL-TPH - BTEX (MW-61AR)	12/1995
MW-38	06/1990		1992
MW-39	06/1990		1992
MW-40	06/1990		1992
MW-58	09/1995		01/2004
MW-61	1995		1997
MW-61A	01/1998		01/2004
MW-61AR	03/2006		sampled
MW-62	1995		1997
MW-62A	01/1998		01/2004
MW-63	1995		1997
MW-63A	01/1998		01/2004
MW-64	1995		01/2004
Elliott Avenue			
MW-30	1989	LNAPL - TPH - BTEX (MW-30 & MW-65)	sampled
MW-31	1989		12/2003
MW-32	1989		04/1991
MW-59	03/1998		<i>no data</i>
MW-65	03/1998		ABANDONED 12/07
MW-66	03/1998		ABANDONED 12/07
MW-69	<i>no data</i>		<i>no data</i>
Lower Yard			
MW-1	<i>no data</i>	No wells in Lower Yard currently sampled for compliance parameters	1998
MW-2	<i>no data</i>		1998
MW-18	<i>no data</i>		1998
MW-22	<i>no data</i>		1998
MW-23	<i>no data</i>		1998
MW-33	<i>no data</i>		1998
MW-34	<i>no data</i>		1998
MW-35	<i>no data</i>		1998
MW-49	<i>no data</i>		1998
MW-50	<i>no data</i>		1998
MW-51	<i>no data</i>		1998
MW-53	<i>no data</i>		1998
MW-54	<i>no data</i>		1998
MW-55	<i>no data</i>		1998
MW-56	<i>no data</i>		1998
MW-57	<i>no data</i>		1998
MW-60	<i>no data</i>		1998
MW-81	09/1998		06/2002
MW-82	09/1998		06/2002
MW-83	09/1998		06/2002
MW-84	09/1998	06/2002	
MW-85	09/1998	06/2002	
MW-86	09/1998	06/2002	

Table 3

Monitoring Well History
Former Unocal Seattle Marketing Terminal
3001 Elliott Avenue
Seattle, Washington

Well ID	Installation Date	Compliance Parameters	Compliance/Removal Date
Offsite Area			
MW-8	01/1989	LNAPL - TPH - BTEX Dissolved Lead PAHs	10/2005
MW-9	<i>no data</i>		07/2005
MW-10	01/1989		10/2005
MW-20	01/1989		10/2005
MW-25	01/1989		10/2005
MW-26	01/1989		10/2005
MW-27	01/1989		damaged 2006
MW-27R	12/2006		ABANDONED 12/07
MW-34	10/1989		<i>no data</i>
MW-35	10/1989		<i>no data</i>
MW-36	10/1989		07/2005
MW-41	10/1990		12/2002
MW-42	10/1990		12/1991
MW-43	10/1990		12/1991
MW-44	<i>no data</i>		<i>no data</i>
MW-52	06/1998		10/2005
MW-67	03/1998		10/2005
MW-68	03/1998		07/2005
MW-69	03/1998		<i>no data</i>
MW-70	03/1998		10/2005
MW-71	03/1998	10/2005	
MW-72	03/1998	07/2005	
MW-76	03/1998	10/2005	
Offsite Area- Amendment No. 4 Point of Compliance monitoring wells			
MW-200	10/2006	LNAPL - TPH - BTEX Dissolved Lead PAHs (MW-200 to MW-207)	sampled
MW-201	10/2006		sampled
MW-202	10/2006		sampled
MW-203	10/2006		sampled
MW-204	10/2006		sampled
MW-205	10/2006		sampled
MW-206	10/2006		sampled
MW-207	10/2006		sampled

Notes:

- LNAPL = Light non-aqueous phase liquid
- TPH = Total petroleum hydrocarbons
- BTEX = Benzene, Toluene, Ethylbenzene and Xylenes (Total)
- PAHs = Polynuclear Aromatic Hydrocarbons
- Items in bold represent compliance wells sampled in the most recent sampling event.

Table 4
Summary of Groundwater Elevation Data

Former Unocal Seattle Marketing Terminal
3001 Elliott Avenue
Seattle, Washington

Well Number ¹ (Well Casing Elevation)	Date Measured	Time Measured (hr:min)	Depth to Groundwater ² (feet)	Depth to LNAPL ³ (feet)	LNAPL Thickness ³ (feet)	Groundwater Elevation ⁴ (feet)	Top of Well Screen Elevation ⁵ (feet)		
MW-27 (6.18)	12/11/02	13:20	9.38	NR	NR	-3.20	--		
	03/20/03	10:31	11.09	NR	NR	-4.91	--		
	07/03/03	9:02	12.10	NR	NR	-5.92	--		
	09/18/03	11:27	10.58	NR	NR	-4.40	--		
	12/02/03	10:56	9.50	NR	NR	-3.32	--		
	03/09/04	10:37	11.83	NR	NR	-5.65	--		
	06/03/04	10:09	12.32	NR	NR	-6.14	--		
	09/03/04	10:35	10.63	NR	NR	-4.45	--		
	12/06/04	10:30	9.41	NR	NR	-3.23	--		
	03/04/05	10:33	9.05	NR	NR	-2.87	--		
	06/03/05	--	13.05	NR	NR	-6.87	--		
	09/01/05	8:00	10.29	NR	NR	-4.11	--		
	12/01/05	9:45	9.28	NR	NR	-3.10	--		
	03/02/06	9:00	9.29	NR	NR	-3.11	--		
				Well Damaged During Construction Activities					
	MW-27R ⁶ (4.37)	03/07/07	9:35	8.25	--	--	-3.88	--	
09/26/07		7:59	9.19	--	--	-4.82	--		
11/26/07		14:55	7.56	--	--	-3.19	--		
	12/03/07		Well Abandoned						
MW-30 (11.29)	12/11/02	14:10	15.23	NR	NR	-3.94	--		
	03/20/03	13:00	12.59	NR	NR	-1.30	--		
	07/03/03	11:18	14.30	NR	NR	-3.01	--		
	09/18/03	10:36	14.70	NR	NR	-3.41	--		
	12/02/03	11:23	12.20	NR	NR	-0.91	--		
	03/09/04	10:58	13.81	NR	NR	-2.52	--		
	06/03/04	11:44	14.60	NR	NR	-3.31	--		
	09/03/04	13:42	9.85	NR	NR	1.44	--		
	12/06/04	9:37	15.27	NR	NR	-3.98	--		
	03/04/05	14:08	14.33	NR	NR	-3.04	--		
	06/03/05	--	14.47	NR	NR	-3.18	--		
	09/01/05	10:05	15.05	NR	NR	-3.76	--		
	12/01/05	11:23	11.98	NR	NR	-0.69	--		
	03/02/06	11:28	14.53	NR	NR	-3.24	--		
	06/06/06	8:20	14.16	NR	NR	-2.87	--		
	09/15/06	--	14.10	NR	NR	-2.81	--		
	03/07/07	8:55	13.74	Sheen	--	-2.45	--		
	06/07/07	8:43	13.87	--	--	-2.58	--		
	07/10/07	9:45	14.21	--	--	-2.92	--		
	07/25/07	11:35	13.94	--	--	-2.65	--		
	08/22/07	9:35	14.15	--	--	-2.86	--		
	09/06/07	9:50	14.25	--	--	-2.96	--		
	09/26/07	9:30	14.52	--	--	-3.23	--		
	10/11/07	7:55	14.22	--	--	-2.93	--		
	11/01/07	9:50	14.29	--	--	-3.00	--		
	11/16/07	15:25	13.85	--	--	-2.56	--		
	11/26/07	13:40	13.80	--	--	-2.51	--		
	12/19/07	9:30	12.59	--	--	-1.30	--		
	01/03/08	8:30	12.60	--	--	-1.31	--		
	01/17/08	8:48	12.53	--	--	-1.24	--		
	01/30/08	9:30	13.10	Sheen	--	-1.81	--		
	02/12/08	9:28	13.27	Sheen	--	-1.98	--		
	03/03/08	9:31	13.80	--	--	-2.51	--		
	03/17/08	9:29	13.99	--	--	-2.70	--		
	04/01/08	9:13	13.78	--	--	-2.49	--		
	04/14/08	9:14	13.97	--	--	-2.68	--		
04/28/08	9:56	14.18	--	--	-2.89	--			
(20.85) ⁶	05/13/08	9:24	14.31	--	--	6.54	--		
	05/27/08	13:40	14.33	--	--	6.52	--		
	06/10/08	10:25	14.08	--	--	6.77	--		
	06/24/08	9:46	14.35	--	--	6.50	--		
	07/07/08	9:50	14.13	--	--	6.72	--		
	07/22/08	9:29	14.19	Sheen	--	6.66	--		
	08/12/08	9:58	14.05	--	--	6.80	--		
	09/03/08	--	14.03	--	--	6.82	--		
	09/26/08	--	14.16	--	--	6.69	--		
	10/17/08	9:15	14.35	--	--	6.50	--		
	10/29/08	8:43	14.49	--	--	6.36	--		
	11/12/08	10:46	13.03	--	--	7.82	--		
12/03/08	12:46	13.75	--	--	7.10	--			

Table 4
Summary of Groundwater Elevation Data

Former Unocal Seattle Marketing Terminal
3001 Elliott Avenue
Seattle, Washington

Well Number ¹ (Well Casing Elevation)	Date Measured	Time Measured (hr:min)	Depth to Groundwater ² (feet)	Depth to LNAPL ³ (feet)	LNAPL Thickness ³ (feet)	Groundwater Elevation ⁴ (feet)	Top of Well Screen Elevation ⁵ (feet)	
MW-30 (cont.)	01/06/09	9:36	12.68	--	--	8.17	--	
	01/20/09	12:46	12.98	--	--	7.87	--	
	02/03/09	9:39	13.79	--	--	7.06	--	
	02/17/09	11:15	13.75	--	--	7.10	--	
	03/12/09	12:09	13.79	--	--	7.06	--	
	03/25/09	8:46	13.70	--	--	7.15	--	
	04/08/09	10:16	13.30	--	--	7.55	--	
	04/30/09	10:09	12.98	--	--	7.87	--	
	05/12/09	10:10	12.72	12.70	0.02	8.15	--	
	05/26/09	14:27	13.20	--	--	7.65	--	
	06/09/09	9:41	13.91	--	--	6.94	--	
	06/25/09	9:43	13.49	--	--	7.36	--	
	07/07/09	9:35	13.75	Sheen	--	7.10	--	
	07/13/09	8:09	14.23	--	--	6.62	--	
	08/05/09	6:45	13.96	Sheen	--	6.89	--	
	08/06/09	9:26	13.99	--	--	6.86	--	
	08/20/09	8:41	14.18	--	--	6.67	--	
	09/10/09	10:11	14.15	--	--	6.70	--	
	09/23/09	9:33	14.07	Sheen	--	6.78	--	
	10/08/09	9:49	14.21	--	--	6.64	--	
	10/19/09	9:20	14.13	--	--	6.72	--	
11/12/09	9:33	12.43	--	--	8.42	--		
03/24/10	9:48	12.98	Sheen	--	7.87	--		
04/13/10	10:31	12.98	Sheen	--	7.87	--		
05/26/10	9:15	13.36	Sheen	--	7.49	--		
07/28/10	14:40	14.11	--	--	6.74	--		
08/05/10	11:49	14.10	--	--	6.75	--		
08/13/10	10:10	13.90	--	--	6.95	--		
08/18/10	8:36	13.92	--	--	6.93	--		
09/21/10	10:29	13.30	--	--	7.55	--		
10/11/10	11:01	13.40	--	--	7.45	--		
11/19/10	14:54	12.41	--	--	8.44	--		
MW-34 (5.33)	12/11/02	13:45	9.45	NR	NR	-4.12	--	
	03/20/03	11:43	6.99	NR	NR	-1.66	--	
	07/03/03	8:29	9.02	NR	NR	-3.69	--	
	09/18/03	9:55	9.57	NR	NR	-4.24	--	
	12/02/03	11:45	7.00	NR	NR	-1.67	--	
	03/09/04	12:15	8.42	NR	NR	-3.09	--	
	06/03/04	11:25	8.95	NR	NR	-3.62	--	
	09/03/04	13:53	8.63	NR	NR	-3.30	--	
	12/06/04	9:45	9.48	NR	NR	-4.15	--	
	03/04/05	13:55	8.87	NR	NR	-3.54	--	
	06/03/05	--	9.08	NR	NR	-3.75	--	
	09/01/05	9:08	9.38	NR	NR	-4.05	--	
	12/01/05	10:49	6.72	NR	NR	-1.39	--	
	03/02/06	10:50	9.25	NR	NR	-3.92	--	
	06/06/06	9:20	8.82	NR	NR	-3.49	--	
	09/15/06	--	8.66	NR	NR	-3.33	--	
	03/07/07	--	--	NR	NR	--	--	
02/13/08	--	--	Well Possibly Removed During Previous Excavation Activities					--
MW-35 (5.11)	12/11/02	13:35	9.29	NR	NR	-4.18	--	
	03/20/03	11:42	7.65	NR	NR	-2.54	--	
	07/03/03	--	--	NR	NR	--	--	
	09/18/03	--	--	NR	NR	--	--	
	12/02/03	--	--	NR	NR	--	--	
	03/09/04	--	--	NR	NR	--	--	
	06/03/04	--	--	NR	NR	--	--	
	09/03/04	--	--	NR	NR	--	--	
	12/06/04	--	--	NR	NR	--	--	
	03/04/05	--	--	NR	NR	--	--	
	06/03/05	--	--	NR	NR	--	--	
	09/01/05	--	--	NR	NR	--	--	
	12/01/05	--	--	NR	NR	--	--	
	03/02/06	--	--	NR	NR	--	--	
	06/06/06	--	--	NR	NR	--	--	
09/15/06	--	--	NR	NR	--	--		
03/07/07	--	--	NR	NR	--	--		
02/13/08	--	--	Well Possibly Removed During Previous Excavation Activities					--

Table 4
Summary of Groundwater Elevation Data

Former Unocal Seattle Marketing Terminal
3001 Elliott Avenue
Seattle, Washington

Well Number ¹ (Well Casing Elevation)	Date Measured	Time Measured (hr:min)	Depth to Groundwater ² (feet)	Depth to LNAPL ³ (feet)	LNAPL Thickness ³ (feet)	Groundwater Elevation ⁴ (feet)	Top of Well Screen Elevation ⁵ (feet)
MW-42 (5.20)	12/11/02	13:30	9.38	NR	NR	-4.18	--
	03/20/03	11:50	7.86	NR	NR	-2.66	--
	07/03/03	8:11	9.44	NR	NR	-4.24	--
	09/18/03	10:21	10.92	NR	NR	-5.72	--
	12/02/03	11:36	9.14	NR	NR	-3.94	--
	03/09/04	10:09	8.58	NR	NR	-3.38	--
	06/03/04	11:10	9.19	NR	NR	-3.99	--
	09/03/04	14:01	9.02	NR	NR	-3.82	--
	12/06/04	9:48	9.43	NR	NR	-4.23	--
	03/04/05	13:56	8.99	NR	NR	-3.79	--
	06/03/05	--	9.24	NR	NR	-4.04	--
	09/01/05	9:00	9.55	NR	NR	-4.35	--
	12/01/05	10:54	8.91	NR	NR	-3.71	--
	03/02/06	10:45	9.25	NR	NR	-4.05	--
	06/06/06	9:28	8.93	NR	NR	-3.73	--
	09/15/06	--	8.87	NR	NR	-3.67	--
	03/07/07	--	--	NR	NR	--	--
	02/13/08	--	--	NR	NR	--	--
	Well Possibly Removed During Previous Excavation Activities						
MW-43 (4.94)	12/11/02	13:40	9.06	NR	NR	-4.12	--
	03/20/03	11:30	7.10	NR	NR	-2.16	--
	07/03/03	8:15	8.86	NR	NR	-3.92	--
	09/18/03	--	--	NR	NR	--	--
	12/02/03	--	--	NR	NR	--	--
	03/09/04	--	--	NR	NR	--	--
	06/03/04	--	--	NR	NR	--	--
	09/03/04	--	--	NR	NR	--	--
	12/06/04	--	--	NR	NR	--	--
	03/04/05	--	--	NR	NR	--	--
	06/03/05	--	--	NR	NR	--	--
	09/01/05	--	--	NR	NR	--	--
	12/01/05	--	--	NR	NR	--	--
	03/02/06	--	--	NR	NR	--	--
	06/06/06	--	--	NR	NR	--	--
	09/15/06	--	--	NR	NR	--	--
	03/07/07	--	--	NR	NR	--	--
	02/13/08	--	--	NR	NR	--	--
	Well Possibly Removed During Previous Excavation Activities						
MW-44 (5.46)	12/11/02	--	--	NR	NR	--	--
	03/20/03	--	--	NR	NR	--	--
	07/03/03	--	--	NR	NR	--	--
	09/18/03	--	--	NR	NR	--	--
	12/02/03	--	--	NR	NR	--	--
	03/09/04	--	--	NR	NR	--	--
	06/03/04	--	--	NR	NR	--	--
	09/03/04	--	--	NR	NR	--	--
	12/06/04	--	--	NR	NR	--	--
	03/04/05	--	--	NR	NR	--	--
	06/03/05	--	--	NR	NR	--	--
	09/01/05	--	--	NR	NR	--	--
	12/01/05	--	--	NR	NR	--	--
03/02/06	--	--	NR	NR	--	--	
06/06/06	--	--	NR	NR	--	--	
09/15/06	--	--	NR	NR	--	--	
03/07/07	--	--	NR	NR	--	--	

Table 4
Summary of Groundwater Elevation Data

Former Unocal Seattle Marketing Terminal
3001 Elliott Avenue
Seattle, Washington

Well Number ¹ (Well Casing Elevation)	Date Measured	Time Measured (hr:min)	Depth to Groundwater ² (feet)	Depth to LNAPL ³ (feet)	LNAPL Thickness ³ (feet)	Groundwater Elevation ⁴ (feet)	Top of Well Screen Elevation ⁵ (feet)	
MW-61A-R ⁶ (13.35)	03/02/06	--	15.15 ⁶	NR	NR	-2.25	1.91	
	06/06/06	8:00	14.96	NR	NR	-2.05	--	
	09/15/06	--	14.26	NR	NR	-1.35	--	
	03/07/07	8:44	14.04	--	NR	-0.69	--	
	06/07/07	9:15	14.36	--	NR	-1.01	--	
	07/10/07	9:50	14.84	--	NR	-1.49	--	
	07/25/07	11:40	14.55	--	NR	-1.20	--	
	08/22/07	9:40	14.72	--	NR	-1.37	--	
	09/06/07	9:55	14.90	--	NR	-1.55	--	
	09/26/07	9:16	15.09	--	NR	-1.74	--	
	10/11/07	8:00	14.82	--	NR	-1.47	--	
	11/01/07	9:55	14.81	--	NR	-1.46	--	
	11/16/07	15:30	14.59	--	NR	-1.24	--	
	11/26/07	13:48	14.31	--	NR	-0.96	--	
	12/19/07	9:35	13.83	--	NR	-0.48	--	
	01/03/08	8:41	12.93	--	NR	0.42	--	
	01/17/08	9:00	12.76	--	NR	0.59	--	
	02/12/08	9:24	13.54	--	NR	-0.19	--	
	03/03/08	9:24	14.14	--	NR	-0.79	--	
	03/17/08	9:23	14.49	--	NR	-1.14	--	
	04/01/08	9:10	14.22	14.21	0.01	-0.86	--	
	04/14/08	9:06	14.41	14.39	0.02	-1.04	--	
	04/28/08	9:36	14.70	14.64	0.06	-1.30	--	
	(22.44) ⁸	05/13/08	9:29	14.88	--	--	7.56	11.00
		05/27/08	13:53	14.93	Sheen	--	7.51	--
		06/10/08	10:20	14.73	--	--	7.71	--
		06/24/08	9:41	14.92	--	--	7.52	--
07/07/08		9:56	14.70	--	--	7.74	--	
07/22/08		9:34	14.72	14.70	0.02	7.74	--	
08/12/08		9:50	14.75	14.68	0.07	7.75	--	
09/03/08		--	15.58	15.56	0.02	6.88	--	
09/26/08		--	14.89	14.79	0.10	7.63	--	
10/17/08		9:03	15.12	14.92	0.20	7.48	--	
10/29/08		8:50	15.21	15.00	0.21	7.40	--	
11/12/08		10:51	13.95	13.81	0.14	8.60	--	
12/03/08		12:52	14.25	14.19	0.06	8.24	--	
01/06/09		9:40	13.12	12.99	0.13	9.42	--	
01/20/09		12:50	13.06	13.01	0.05	9.42	--	
02/03/09		9:43	14.40	13.88	0.52	8.46	--	
02/17/09		11:20	14.30	13.80	0.50	8.54	--	
03/12/09		12:16	14.20	14.05	0.15	8.36	--	
03/25/09		8:50	14.01	13.91	0.10	8.51	--	
04/08/09		10:21	13.81	13.71	0.10	8.71	--	
04/30/09		10:12	14.14	13.95	0.19	8.45	--	
05/12/09		10:51	13.66	13.64	0.02	8.80	--	
05/26/09		14:15	13.74	--	--	8.70	--	
06/09/09		9:46	13.40	--	--	9.04	--	
06/25/09		9:47	14.14	13.94	0.20	8.46	--	
07/07/09		9:40	14.18	14.15	0.03	8.28	--	
07/13/09		8:14	14.88	14.87	0.01	7.57	--	
08/05/09		6:45	14.68	14.39	0.29	7.99	--	
08/06/09		9:29	14.64	14.62	0.02	7.82	--	
08/20/09		8:51	14.85	14.84	0.01	7.60	--	
09/10/09		10:15	14.84	14.78	0.06	7.65	--	
09/23/09		9:37	14.89	14.81	0.08	7.61	--	
10/08/09		9:39	15.01	14.94	0.07	7.49	--	
10/19/09	9:05	14.98	14.91	0.07	7.52	--		
11/12/09	9:36	12.85	12.80	0.05	9.63	--		
03/24/10	9:54	13.20	12.95	0.25	9.44	--		
04/13/10	10:37	13.06	12.95	0.11	9.47	--		
05/26/10	9:06	13.91	13.76	0.15	8.65	--		
07/28/10	14:56	14.78	--	--	7.66	--		
08/05/10	11:28	14.79	--	--	7.65	--		
08/13/10	9:38	13.62	--	--	8.82	--		
08/13/10	10:37	13.61	--	--	8.83	--		
08/13/10	10:42	13.61	--	--	8.83	--		
08/13/10	15:42	13.64	--	--	8.80	--		
08/18/10	8:55	14.70	--	--	7.74	--		
09/21/10	10:42	15.35	--	--	7.09	--		
10/11/10	11:20	14.35	14.31	0.04	8.12	--		
11/19/10	15:25	13.30	13.19	0.11	-13.21	--		

Table 4
Summary of Groundwater Elevation Data

Former Unocal Seattle Marketing Terminal
3001 Elliott Avenue
Seattle, Washington

Well Number ¹ (Well Casing Elevation)	Date Measured	Time Measured (hr:min)	Depth to Groundwater ² (feet)	Depth to LNAPL ³ (feet)	LNAPL Thickness ³ (feet)	Groundwater Elevation ⁴ (feet)	Top of Well Screen Elevation ⁵ (feet)	
MW-65 (10.83)	12/11/02	14:03	14.69	NR	NR	-3.86	--	
	03/20/03	10:44	10.09	NR	NR	0.74	--	
	07/03/03	11:12	13.85	NR	NR	-3.02	--	
	09/18/03	10:40	14.15	NR	NR	-3.32	--	
	12/02/03	11:14	12.38	NR	NR	-1.55	--	
	03/09/04	10:50	13.63	NR	NR	-2.80	--	
	06/03/04	11:42	14.24	NR	NR	-3.41	--	
	09/03/04	14:08	13.77	NR	NR	-2.94	--	
	12/06/04	9:32	14.59	NR	NR	-3.76	--	
	03/04/05	14:04	14.06	NR	NR	-3.23	--	
	06/03/05	--	14.14	NR	NR	-3.31	--	
	09/01/05	9:55	14.67	NR	NR	-3.84	--	
	12/01/05	11:19	12.05	NR	NR	-1.22	--	
	03/02/06	11:12	14.28	NR	NR	-3.45	--	
	06/06/06	8:26	13.83	NR	NR	-3.00	--	
	09/15/06	--	13.90	NR	NR	-3.07	--	
	03/07/07	8:51	13.63	--	--	-2.80	--	
	06/07/07	8:30	13.69	--	--	-2.86	--	
	09/26/07	9:27	14.29	--	--	-3.46	--	
	11/26/07	10:00	13.62	--	--	-2.79	--	
	12/03/07			Well Decommissioned				
MW-66 (11.62)	12/11/02	14:15	15.36	NR	NR	-3.74	--	
	03/20/03	13:04	12.21	NR	NR	-0.59	--	
	07/03/03	11:22	14.73	NR	NR	-3.11	--	
	09/18/03	10:34	15.25	NR	NR	-3.63	--	
	12/02/03	11:27	11.99	NR	NR	-0.37	--	
	03/09/04	11:02	13.67	NR	NR	-2.05	--	
	06/03/04	11:45	14.78	NR	NR	-3.16	--	
	09/03/04	14:12	14.16	NR	NR	-2.54	--	
	12/06/04	9:39	15.22	NR	NR	-3.60	--	
	03/04/05	14:01	14.54	NR	NR	-2.92	--	
	06/03/05	--	14.69	NR	NR	-3.07	--	
	09/01/05	10:10	15.31	NR	NR	-3.69	--	
	12/01/05	11:26	11.78	NR	NR	-0.16	--	
	03/02/06	11:20	14.77	NR	NR	-3.15	--	
	06/06/06	8:15	14.35	NR	NR	-2.73	--	
	09/15/06	--	14.39	NR	NR	-2.77	--	
	03/07/07	9:00	14.11	--	--	-2.49	--	
	09/26/07	9:36	14.97	--	--	-3.35	--	
	11/26/07	13:42	14.23	--	--	-2.61	--	
		12/03/07			Well Decommissioned			
MW-200 ⁶ (4.78) (14.36) ⁹	03/07/07	9:45	8.88	--	--	-4.10	-0.22	
	06/07/07	15:53	9.26	--	--	-4.48	--	
	07/06/07	10:00	9.76	--	--	-4.98	--	
	09/26/07	8:08	9.43	--	--	-4.65	--	
	11/26/07	14:48	8.54	--	--	-3.76	--	
	02/13/08	11:15	8.59	--	--	-3.82	--	
	05/13/08	10:16	10.02	--	--	4.34	9.36	
	09/03/08	--	9.56	--	--	4.80	--	
	12/03/08	12:10	9.11	--	--	5.25	--	
	02/17/09	10:43	8.28	--	--	6.08	--	
	05/12/09	12:02	8.95	--	--	5.41	--	
	05/26/09	13:54	9.40	--	--	4.96	--	
	09/10/09	10:39	9.74	--	--	4.62	--	
	04/13/10	11:21	9.23	--	--	5.13	--	
	06/16/10	10:05	9.10	--	--	5.26	--	
	08/12/10	9:45	8.92		Sheen	--	5.44	--
	09/14/10	1:48	9.31	--	--	5.05	--	
	09/14/10	1:53	9.31	--	--	5.05	--	
	09/15/10	15:03	9.34	--	--	5.02	--	
	09/15/10	15:05	9.33	--	--	5.03	--	
	09/15/10	15:10	9.31	--	--	5.05	--	
	09/15/10	15:15	9.29	--	--	5.07	--	
	09/15/10	15:20	9.28	--	--	5.08	--	
	09/15/10	15:25	9.26	--	--	5.10	--	
	09/15/10	15:35	9.38	--	--	4.98	--	
	09/15/10	15:39	9.49	--	--	4.87	--	
	09/15/10	15:45	9.58	--	--	4.78	--	
	09/15/10	15:50	9.66	--	--	4.70	--	
	09/15/10	15:55	9.70	--	--	4.66	--	
	09/15/10	16:00	9.74	--	--	4.62	--	
	09/15/10	16:05	9.76	--	--	4.60	--	
	09/15/10	16:10	9.79	--	--	4.57	--	
	09/15/10	16:16	9.82	--	--	4.54	--	
	09/15/10	16:28	9.80	--	--	4.56	--	
	09/15/10	16:31	9.69	--	--	4.67	--	
	09/15/10	16:36	9.56	--	--	4.80	--	
09/15/10	16:40	9.50	--	--	4.86	--		
09/15/10	16:46	9.43	--	--	4.93	--		
09/15/10	16:55	9.35	--	--	5.01	--		
09/15/10	17:05	9.27	--	--	5.09	--		
09/15/10	17:20	9.21	--	--	5.15	--		
09/15/10	17:29	9.20	--	--	5.16	--		
09/21/10	11:14	9.50	--	--	4.86	--		
09/22/10	11:00	9.40	--	--	4.96	--		

Table 4
Summary of Groundwater Elevation Data

Former Unocal Seattle Marketing Terminal
3001 Elliott Avenue
Seattle, Washington

Well Number ¹ (Well Casing Elevation)	Date Measured	Time Measured (hr:min)	Depth to Groundwater ² (feet)	Depth to LNAPL ³ (feet)	LNAPL Thickness ³ (feet)	Groundwater Elevation ⁴ (feet)	Top of Well Screen Elevation ⁵ (feet)
MW-201 ^b (5.28) (14.86) ^b	03/07/07	9:55	9.41	Sheen	--	-4.13	0.28
	06/07/07	16:35	9.79	--	--	-4.51	--
	07/06/07	11:00	10.27	--	--	-4.99	--
	09/26/07	8:20	9.97	--	--	-4.69	--
	11/26/07	14:38	9.09	--	--	-3.81	--
	02/12/08	10:24	9.46	--	--	-4.19	--
	05/13/08	10:24	10.56	--	--	4.30	9.86
	09/03/08	--	10.08	--	--	4.78	--
	12/03/08	12:17	9.66	--	--	5.20	--
	02/17/09	10:37	8.82	--	--	6.04	--
	05/12/09	12:13	9.52	--	--	5.34	--
	05/26/09	13:50	9.90	--	--	4.96	--
	08/11/09	9:02	10.31	--	--	4.55	--
	08/28/09	14:50	10.21	--	--	4.65	--
	09/10/09	10:42	10.29	--	--	4.57	--
	04/13/10	11:17	9.75	--	--	5.11	--
	08/11/10	14:45	10.68	Sheen	--	4.18	--
	09/14/10	13:55	9.89	--	--	4.97	--
	09/14/10	14:00	9.89	--	--	4.97	--
	09/14/10	15:05	10.04	--	--	4.82	--
	09/14/10	15:07	10.02	--	--	4.84	--
	09/14/10	15:19	9.92	--	--	4.94	--
	09/14/10	15:26	9.89	--	--	4.97	--
09/14/10	15:36	9.86	--	--	5.00	--	
09/17/10	18:14	9.59	--	--	5.27	--	
09/17/10	20:07	9.36	--	--	5.50	--	
09/21/10	11:18	10.06	--	--	4.80	--	
MW-202 ^b (5.01) (14.58) ^b	03/07/07	9:25	8.79	--	--	-3.78	-2.74
	06/07/07	14:53	9.52	--	--	-4.51	--
	07/06/07	10:05	10.16	--	--	-5.15	--
	09/26/07	7:48	9.59	--	--	-4.58	--
	11/26/07	15:16	8.43	--	--	-3.42	--
	02/12/08	10:26	8.59	--	--	-3.59	--
	05/13/08	10:06	10.61	--	--	3.97	6.83
	09/03/08	--	9.61	--	--	4.97	--
	12/03/08	11:55	8.86	--	--	5.72	--
	02/17/09	10:32	8.15	--	--	6.43	--
	05/12/09	11:58	9.77	--	--	4.81	--
	05/26/09	13:56	10.84	--	--	3.74	--
	08/11/09	9:25	9.96	--	--	4.62	--
	08/28/09	14:29	9.85	--	--	4.73	--
	09/10/09	10:58	9.90	--	--	4.68	--
	04/13/10	11:23	10.17	--	--	4.41	--
	06/16/10	9:58	8.95	--	--	5.63	--
	08/11/10	11:45	10.00	--	--	4.58	--
	08/16/10	14:40	8.46	--	--	6.12	--
	08/16/10	14:43	8.46	--	--	6.12	--
	08/16/10	14:45	9.01	--	--	5.57	--
	08/16/10	14:57	9.02	--	--	5.56	--
	08/16/10	14:48	9.06	--	--	5.52	--
	08/16/10	14:49	9.13	--	--	5.45	--
	08/16/10	14:50	9.14	--	--	5.44	--
	08/16/10	14:51	9.13	--	--	5.45	--
	08/16/10	14:56	9.19	--	--	5.39	--
	08/16/10	14:56	8.75	--	--	5.83	--
	08/16/10	14:57	8.60	--	--	5.98	--
	08/16/10	14:57	8.59	--	--	5.99	--
08/16/10	14:58	8.53	--	--	6.05	--	
08/18/10	9:12	11.12	--	--	3.46	--	
09/17/10	14:32	18.86	--	--	-4.28	--	
09/17/10	16:18	9.18	--	--	5.40	--	
09/17/10	17:52	8.83	--	--	5.75	--	
09/21/10	11:10	10.55	--	--	4.03	--	
09/22/10	9:30	9.66	--	--	4.92	--	

Table 4
Summary of Groundwater Elevation Data

Former Unocal Seattle Marketing Terminal
3001 Elliott Avenue
Seattle, Washington

Well Number ¹ (Well Casing Elevation)	Date Measured	Time Measured (hr:min)	Depth to Groundwater ² (feet)	Depth to LNAPL ³ (feet)	LNAPL Thickness ³ (feet)	Groundwater Elevation ⁴ (feet)	Top of Well Screen Elevation ⁵ (feet)	
MW-203 ^b (7.98)	03/07/07	--	11.86	--	--	-3.88	-2.52	
	06/07/07	13:54	12.45	--	--	-4.47	--	
	07/06/07	11:01	13.07	--	--	-5.09	--	
	09/26/07	8:30	12.69	--	--	-4.71	--	
	11/29/07	7:44	13.26	--	--	-4.98	--	
	02/12/08	10:05	11.59	--	--	-3.62	--	
	(17.55) ^b	05/13/08	10:32	13.56	--	--	3.99	7.05
		09/03/08	--	13.40	--	--	4.15	--
		12/03/08	12:26	11.76	--	--	5.79	--
		02/17/09	10:47	11.00	--	--	6.55	--
		05/12/09	12:21	12.81	--	--	4.74	--
		05/26/09	13:45	13.51	--	--	4.04	--
		08/28/09	15:14	12.67	--	--	4.88	--
		09/10/09	10:45	12.99	--	--	4.56	--
		04/13/10	11:12	12.92	--	--	4.63	--
		07/21/10	16:30	12.59	--	--	4.96	--
		08/11/10	11:12	11.68	--	--	5.87	--
		08/11/10	11:28	11.89	--	--	5.66	--
		08/11/10	11:29	11.84	--	--	5.71	--
		08/13/10	16:15	13.10	--	--	4.45	--
08/16/10		7:12	13.96	--	--	3.59	--	
08/16/10		7:13	13.96	--	--	3.59	--	
09/02/10		14:45	12.76	--	--	4.79	--	
09/02/10		14:55	12.71	--	--	4.84	--	
09/02/10		15:10	12.31	--	--	5.24	--	
09/02/10		15:33	12.56	--	--	4.99	--	
09/15/10	6:47	14.20	--	--	3.35	--		
09/16/10	15:55	12.02	--	--	5.53	--		
09/16/10	16:00	12.01	--	--	5.54	--		
09/16/10	16:11	11.95	--	--	5.60	--		
09/16/10	16:20	11.90	--	--	5.65	--		
09/21/10	11:28	13.54	--	--	4.01	--		
MW-204 ^b (14.38)	03/07/07	10:15	18.12	--	--	-3.74	-2.87	
	06/07/07	14:50	18.52	--	--	-4.14	--	
	07/06/07	11:40	19.03	--	--	-4.65	--	
	09/26/07	8:37	18.85	--	--	-4.47	--	
	11/26/07	14:29	17.78	--	--	-3.40	--	
	02/12/08	10:03	17.85	--	--	-3.48	--	
	(23.93) ^b	05/13/08	10:38	19.43	--	--	4.50	6.68
		09/03/08	--	18.76	--	--	5.17	--
		10/01/08	10:25	18.40	--	--	5.53	--
		10/17/08	9:29	18.72	--	--	5.21	--
		12/03/08	12:31	18.06	--	--	5.87	--
		02/17/09	10:54	17.42	--	--	6.51	--
		05/12/09	12:41	19.81	--	--	4.12	--
		05/26/09	13:41	19.20	--	--	4.73	--
		07/13/09	8:18	19.82	--	--	4.11	--
		08/04/09	--	18.88	--	--	5.05	--
		08/06/09	9:36	18.33	--	--	5.60	--
		08/20/09	9:02	18.21	--	--	5.72	--
		09/10/09	10:47	19.02	--	--	4.91	--
		04/13/10	10:59	18.71	--	--	5.22	--
		06/16/10	10:15	18.06	--	--	5.87	--
		08/11/10	16:16	18.65	--	--	5.28	--
		08/12/10	12:31	18.11	--	--	5.82	--
		08/12/10	12:34	18.12	--	--	5.81	--
		08/12/10	16:13	18.95	--	--	4.98	--
		08/12/10	16:15	18.94	--	--	4.99	--
		08/12/10	16:17	18.90	--	--	5.03	--
		08/13/10	16:25	18.79	--	--	5.14	--
		08/14/10	7:17	19.70	--	--	4.23	--
		08/14/10	7:18	19.70	--	--	4.23	--
		09/02/10	14:33	18.93	--	--	5.00	--
		09/02/10	14:35	18.93	--	--	5.00	--
		09/02/10	14:39	18.93	--	--	5.00	--
		09/02/10	15:37	18.73	--	--	5.20	--
		09/02/10	17:35	18.57	--	--	5.36	--
		09/14/10	11:58	18.91	--	--	5.02	--
		09/14/10	12:37	18.70	--	--	5.23	--
		09/14/10	12:46	18.65	--	--	5.28	--
		09/16/10	7:10	19.67	--	--	4.26	--
		09/16/10	7:12	19.67	--	--	4.26	--
		09/16/10	7:13	19.67	--	--	4.26	--
		09/16/10	7:14	19.68	--	--	4.25	--
		09/16/10	7:15	19.68	--	--	4.25	--
		09/16/10	7:17	19.69	--	--	4.24	--
		09/16/10	7:19	19.69	--	--	4.24	--
		09/16/10	7:21	19.70	--	--	4.23	--
		09/16/10	7:23	19.70	--	--	4.23	--
09/16/10		7:25	19.71	--	--	4.22	--	
09/16/10		7:27	19.72	--	--	4.21	--	
09/16/10		7:29	19.72	--	--	4.21	--	
09/16/10		7:30	19.75	--	--	4.18	--	
09/17/10	14:30	18.93	--	--	5.00	--		
09/17/10	16:20	18.47	--	--	5.46	--		
09/17/10	19:57	18.26	--	--	5.67	--		
09/21/10	11:35	19.18	--	--	4.75	--		

Table 4
Summary of Groundwater Elevation Data

Former Unocal Seattle Marketing Terminal
3001 Elliott Avenue
Seattle, Washington

Well Number ¹ (Well Casing Elevation)	Date Measured	Time Measured (hr:min)	Depth to Groundwater ² (feet)	Depth to LNAPL ³ (feet)	LNAPL Thickness ³ (feet)	Groundwater Elevation ⁴ (feet)	Top of Well Screen Elevation ⁵ (feet)
MW-205 ⁶ (18.43) (27.89) ⁸	03/07/07	10:30	22.20	Sheen	--	-3.77	0.43
	06/07/07	15:45	22.45	--	--	-4.02	--
	07/06/07	11:47	22.93	--	--	-4.50	--
	09/26/07	8:46	22.83	--	--	-4.40	--
	11/26/07	14:23	21.76	--	--	-3.33	--
	02/12/08	10:01	21.78	--	--	-3.36	--
	05/13/08	10:43	23.38	--	--	4.51	9.89
	09/03/08	--	22.68	--	--	5.21	--
	12/03/08	12:36	22.01	--	--	5.88	--
	02/17/09	10:59	21.40	--	--	6.49	--
	05/12/09	12:47	22.73	--	--	5.16	--
	05/26/09	13:36	23.06	--	--	4.83	--
	08/04/09	--	22.84	--	--	5.05	--
	08/28/09	15:34	22.71	--	--	5.18	--
	09/10/09	10:46	23.01	--	--	4.88	--
	04/13/10	11:07	22.62	--	--	5.27	--
	08/13/10	8:45	22.31	--	--	5.58	--
	08/16/10	14:18	21.50	--	--	6.39	--
	08/16/10	12:22	21.75	--	--	6.14	--
	09/14/10	11:59	22.66	--	--	5.23	--
	09/16/10	9:24	24.00	--	--	3.89	--
	09/16/10	9:25	24.00	--	--	3.89	--
	09/16/10	9:28	24.00	--	--	3.89	--
	09/16/10	15:05	22.42	--	--	5.47	--
	09/17/10	13:43	23.12	--	--	4.77	--
	09/17/10	13:48	23.11	--	--	4.78	--
	09/17/10	13:55	23.05	--	--	4.84	--
	09/17/10	14:00	23.05	--	--	4.84	--
	09/17/10	14:04	23.02	--	--	4.87	--
	09/17/10	14:09	23.03	--	--	4.86	--
	09/17/10	14:19	22.96	--	--	4.93	--
	09/17/10	14:26	22.92	--	--	4.97	--
	09/21/10	11:40	23.15	--	--	4.74	--
09/28/10	8:15	23.05	--	Sheen ⁹	4.84	--	
10/11/10	10:48	21.89	--	--	6.00	--	
MW-206 ⁶ (5.59) (15.15) ⁸	03/07/07	9:15	9.15	--	--	-3.56	-5.41
	06/07/07	13:26	10.24	--	--	-4.65	--
	07/06/07	9:22	10.84	--	--	-5.25	--
	09/26/07	7:35	10.21	--	--	-4.62	--
	11/26/07	15:08	8.47	--	--	-2.88	--
	02/12/08	10:28	8.69	--	--	-3.11	--
	05/13/08	9:59	11.80	--	--	3.35	4.15
	09/03/08	--	9.91	--	--	5.24	--
	10/01/08	9:30	9.21	--	--	5.94	--
	12/03/08	11:51	8.78	--	--	6.37	--
	02/17/09	10:29	8.28	--	--	6.87	--
	05/12/09	11:47	11.83	--	--	3.32	--
	05/26/09	13:59	13.30	--	--	1.85	--
	08/11/09	9:38	10.02	--	--	5.13	--
	08/28/09	14:07	9.78	--	--	5.37	--
	09/10/09	11:14	9.81	--	--	5.34	--
	04/13/10	11:27	12.60	--	--	2.55	--
	08/11/10	17:30	13.10	--	--	2.05	--
	08/16/10	11:52	9.70	--	--	5.45	--
	08/16/10	12:26	8.60	--	--	6.55	--
	08/18/10	9:07	13.10	--	--	2.05	--
	09/17/10	16:12	8.69	--	--	6.46	--
	09/17/10	17:55	10.03	--	--	5.12	--
	09/21/10	11:07	12.65	--	--	2.50	--
	09/22/10	9:20	11.09	--	--	4.06	--

Table 4
Summary of Groundwater Elevation Data

Former Unocal Seattle Marketing Terminal
3001 Elliott Avenue
Seattle, Washington

Well Number ¹ (Well Casing Elevation)	Date Measured	Time Measured (hr:min)	Depth to Groundwater ² (feet)	Depth to LNAPL ³ (feet)	LNAPL Thickness ³ (feet)	Groundwater Elevation ⁴ (feet)	Top of Well Screen Elevation ⁵ (feet)
MW-207 ⁶ (5.82)	03/07/07	10:40	10.64	--	--	-4.82	-3.68
	06/07/07	17:10	10.53	--	--	-4.71	--
	07/06/07	9:10	11.20	--	--	-5.38	--
	09/26/07	7:25	10.30	--	--	-4.48	--
	11/26/07	15:03	8.84	--	--	-3.02	--
	02/12/08	10:31	8.90	--	--	-3.08	--
	05/13/08	9:53	12.07	--	--	3.33	5.90
	09/03/08	--	10.14	--	--	5.26	--
	10/01/08	8:10	9.51	--	--	5.89	--
	12/03/08	11:46	9.05	--	--	6.35	--
	02/17/09	10:25	8.40	--	--	7.00	--
	05/12/09	11:43	11.70	--	--	3.70	--
	05/26/09	14:03	13.52	--	--	1.88	--
	08/11/09	9:46	10.41	--	--	4.99	--
	08/28/09	13:45	10.35	--	--	5.05	--
	09/10/09	11:25	10.20	--	--	5.20	--
	04/13/10	11:30	12.43	--	--	2.97	--
	06/16/10	9:54	9.70	--	--	5.70	--
	08/13/10	13:30	12.52	--	--	2.88	--
	08/16/10	11:22	10.35	--	--	5.05	--
08/16/10	11:25	10.32	--	--	5.08	--	
08/16/10	11:28	10.32	--	--	5.08	--	
08/16/10	11:31	10.29	--	--	5.11	--	
08/16/10	11:33	10.26	--	--	5.14	--	
08/16/10	11:37	10.25	--	--	5.15	--	
08/16/10	11:50	9.70	--	--	5.70	--	
09/21/10	11:02	12.55	--	--	2.85	--	
RW-1 (4.65)	09/13/07	--	9.12	--	--	-4.47	--
	11/01/07	10:45	9.60	--	--	-4.95	--
	11/26/07	11:57	8.43	--	--	-3.78	--
	12/07/07	11:55	7.00	--	--	-2.35	--
	12/19/07	9:25	7.75	--	--	-3.10	--
	01/03/08	9:05	7.78	--	--	-3.13	--
	01/30/07	8:34	8.22	--	--	-3.57	--
	02/12/08	9:00	8.55	--	--	-3.90	--
	03/03/08	8:58	8.88	--	--	-4.23	--
	03/17/08	8:52	8.80	--	--	-4.15	--
	04/01/08	8:49	8.79	--	--	-4.14	--
	04/14/08	8:51	8.85	--	--	-4.20	--
	04/28/08	9:01	8.90	--	--	-4.25	--
	05/13/08	9:10	9.25	--	--	4.95	--
	05/27/08	10:25	9.05	--	--	5.15	--
	06/10/08	10:36	8.88	--	--	5.32	--
	06/24/08	9:15	8.98	--	--	5.22	--
	07/07/08	9:26	8.65	--	--	5.55	--
	07/22/08	9:15	8.88	--	--	5.32	--
	08/12/08	9:23	8.86	--	--	5.34	--
	09/03/08	--	9.13	--	--	5.07	--
	10/17/08	8:29	6.33	--	--	7.87	--
	10/29/08	8:17	9.23	--	--	4.97	--
	11/12/08	9:09	7.63	--	--	6.57	--
	12/03/08	11:25	9.82	--	--	4.38	--
	01/06/09	9:15	7.86	--	--	6.34	--
	01/20/09	12:20	8.34	--	--	5.86	--
	02/03/09	9:08	8.89	--	--	5.31	--
	02/17/09	9:06	8.41	--	--	5.79	--
	03/12/09	11:18	8.75	--	--	5.45	--
	03/25/09	9:05	8.62	--	--	5.58	--
	04/08/09	9:14	8.58	--	--	5.62	--
	04/30/09	9:20	8.55	--	--	5.65	--
	05/12/09	9:21	7.98	--	--	6.22	--
	05/26/09	13:19	8.24	--	--	5.96	--
	06/09/09	9:09	8.00	--	--	6.20	--
	06/25/09	9:19	8.08	--	--	6.12	--
	07/07/09	9:13	8.34	--	--	5.86	--
	09/10/09	9:52	8.98	--	--	5.22	--
	09/23/09	9:09	8.98	--	--	5.22	--
10/08/09	9:24	9.01	--	--	5.19	--	
10/19/09	9:36	8.60	--	--	5.60	--	
11/12/09	9:10	7.75	--	--	6.45	--	
03/24/10	9:24	8.39	--	--	5.81	--	
04/13/10	10:15	8.29	--	--	5.91	--	
05/24/10	10:14	8.38	--	--	5.82	--	
09/21/10	9:59	8.00	--	--	6.20	--	

Table 4
Summary of Groundwater Elevation Data

Former Unocal Seattle Marketing Terminal
3001 Elliott Avenue
Seattle, Washington

Well Number ¹ (Well Casing Elevation)	Date Measured	Time Measured (hr:min)	Depth to Groundwater ² (feet)	Depth to LNAPL ³ (feet)	LNAPL Thickness ³ (feet)	Groundwater Elevation ⁴ (feet)	Top of Well Screen Elevation ⁵ (feet)
RW-2 (4.47) (14.3) ²	04/28/08	9:10	9.98	--	--	-5.51	--
	05/13/08	9:08	8.29	--	--	6.01	--
	05/27/08	10:23	9.12	--	--	5.18	--
	06/10/08	10:38	9.00	--	--	5.30	--
	06/24/08	9:19	9.12	--	--	5.18	--
	07/07/08	9:30	8.86	--	--	5.44	--
	07/22/08	9:19	9.03	--	--	5.27	--
	08/12/08	9:27	8.78	--	--	5.52	--
	09/03/08	--	9.23	--	--	5.07	--
	10/17/08	8:35	6.34	--	--	7.96	--
	10/29/08	8:21	9.37	--	--	4.93	--
	11/12/08	9:13	6.32	--	--	7.98	--
	12/03/08	11:23	8.92	--	--	5.38	--
	01/06/09	9:18	6.84	--	--	7.46	--
	01/20/09	12:23	8.40	--	--	5.90	--
	02/03/09	9:13	9.08	--	--	5.22	--
	02/17/09	9:09	8.55	--	--	5.75	--
	03/12/09	11:21	8.91	--	--	5.39	--
	03/25/09	9:07	8.50	--	--	5.80	--
	04/08/09	9:18	8.68	--	--	5.62	--
	04/30/09	9:24	8.70	--	--	5.60	--
	05/12/09	9:15	8.15	--	--	6.15	--
	05/26/09	13:17	8.31	--	--	5.99	--
	06/09/09	9:13	8.21	--	--	6.09	--
	06/25/09	9:22	8.28	--	--	6.02	--
	07/07/09	9:17	8.49	--	--	5.81	--
	09/10/09	9:50	9.11	--	--	5.19	--
	09/23/09	9:12	9.10	--	--	5.20	--
	10/08/09	9:27	9.24	--	--	5.06	--
	10/19/09	9:40	8.72	--	--	5.58	--
	11/12/09	9:12	7.16	--	--	7.14	--
	03/24/10	9:28	8.42	--	--	5.88	--
	04/13/10	10:12	8.35	--	--	5.95	--
	05/24/10	10:16	8.46	--	--	5.84	--
	08/16/10	7:40	7.87	--	--	6.43	--
	08/16/10	7:42	7.87	--	--	6.43	--
	09/02/10	10:14	9.24	--	--	5.06	--
	09/02/10	10:42	9.25	--	--	5.05	--
	09/02/10	11:45	9.32	--	--	4.98	--
	09/02/10	11:46	9.32	--	--	4.98	--
	09/02/10	11:47	9.32	--	--	4.98	--
	09/02/10	11:48	9.32	--	--	4.98	--
09/02/10	11:49	9.32	--	--	4.98	--	
09/02/10	11:55	9.33	--	--	4.97	--	
09/02/10	12:00	9.33	--	--	4.97	--	
09/02/10	12:05	9.33	--	--	4.97	--	
09/02/10	12:10	9.33	--	--	4.97	--	
09/02/10	12:15	9.34	--	--	4.96	--	
09/02/10	12:20	9.34	--	--	4.96	--	
09/02/10	12:25	9.34	--	--	4.96	--	
09/02/10	12:42	9.35	--	--	4.95	--	
09/02/10	13:00	9.36	--	--	4.94	--	
09/02/10	13:32	9.36	--	--	4.94	--	
09/03/10	9:12	9.52	--	--	4.78	--	
09/03/10	10:26	9.48	--	--	4.82	--	
09/03/10	10:54	9.55	--	--	4.75	--	
09/03/10	11:08	9.54	--	--	4.76	--	
09/21/10	9:57	8.10	--	--	6.20	--	

Table 4
Summary of Groundwater Elevation Data

Former Unocal Seattle Marketing Terminal
3001 Elliott Avenue
Seattle, Washington

Well Number ¹ (Well Casing Elevation)	Date Measured	Time Measured (hr:min)	Depth to Groundwater ² (feet)	Depth to LNAPL ³ (feet)	LNAPL Thickness ³ (feet)	Groundwater Elevation ⁴ (feet)	Top of Well Screen Elevation ⁵ (feet)	
RW-3 (4.70)	09/13/07	--	9.45	--	--	-4.75	--	
	11/01/07	10:52	10.00	--	--	-5.30	--	
	11/26/07	12:00	8.60	--	--	-3.90	--	
	12/07/07	11:50	7.10	--	--	-2.40	--	
	12/19/07	9:20	7.63	--	--	-2.93	--	
	01/03/08	9:07	7.49	--	--	-2.79	--	
	01/30/08	8:38	8.44	--	--	-3.74	--	
	02/12/08	9:30	8.84	--	--	-4.14	--	
	03/03/08	9:02	9.11	--	--	-4.41	--	
	03/17/08	8:58	8.91	--	--	-4.21	--	
	04/01/08	8:43	9.01	--	--	-4.31	--	
	04/14/08	8:44	9.16	--	--	-4.46	--	
	04/28/08	9:16	9.10	--	--	-4.40	--	
	(14.3) ⁵	05/13/08	9:03	9.53	--	--	4.77	--
		05/27/08	10:20	9.36	--	--	4.94	--
		06/10/08	10:41	9.34	Sheen	--	4.96	--
		06/24/08	9:23	9.34	--	--	4.96	--
		07/07/08	9:34	9.04	--	--	5.26	--
		07/22/08	9:22	9.21	--	--	5.09	--
		08/12/08	9:30	9.21	--	--	5.09	--
		09/03/08	--	9.51	--	--	4.79	--
		10/17/08	8:39	9.60	--	--	4.70	--
		10/29/08	8:26	9.53	--	--	4.77	--
		11/12/08	9:17	7.10	--	--	7.20	--
		12/03/08	11:19	8.04	--	--	6.26	--
		01/06/09	9:21	7.69	--	--	6.61	--
		01/20/09	12:26	8.58	--	--	5.72	--
		02/03/09	9:17	9.22	Sheen	--	5.08	--
		02/17/09	9:11	8.69	--	--	5.61	--
		03/12/09	11:24	9.08	--	--	5.22	--
		03/25/09	9:09	8.91	8.90	0.01	5.40	--
		04/08/09	9:20	8.83	8.82	0.01	5.48	--
		04/30/09	9:25	8.90	Sheen	--	5.40	--
		05/12/09	9:26	8.45	Sheen	--	5.85	--
		05/26/09	14:38	9.09	--	--	5.21	--
		06/09/09	9:16	8.40	--	--	5.90	--
		06/25/09	9:23	8.35	--	--	5.95	--
		07/07/09	9:21	8.62	--	--	5.68	--
		08/20/09	8:26	8.60	Sheen	--	5.70	--
		08/28/09	16:00	9.76	--	--	4.54	--
09/10/09	9:47	9.54	--	--	4.76	--		
09/23/09	9:16	9.41	Sheen	--	4.89	--		
10/08/09	9:30	9.46	--	--	4.84	--		
10/19/09	9:45	9.13	--	--	5.17	--		
11/12/09	9:15	8.36	--	--	5.94	--		
03/24/10	9:31	8.60	Sheen	--	5.70	--		
04/13/10	10:09	8.58	--	--	5.72	--		
05/24/10	10:18	8.82	--	--	5.48	--		
08/16/10	7:40	8.40	--	--	5.90	--		
08/16/10	7:50	8.36	--	--	5.94	--		
09/02/10	10:13	9.81	--	--	4.49	--		
09/02/10	10:40	9.79	--	--	4.51	--		
09/21/10	9:55	8.58	--	--	5.72	--		
11/19/10	16:32	7.73	--	--	6.57	--		
RW-4	UNABLE TO LOCATE							
RW-5	09/13/07	--	8.6	--	--	5.30	--	
	11/01/07	11:00	9.4	--	--	4.50	--	
	11/26/07	12:05	7.89	--	--	6.01	--	
	12/07/07	11:45	6.4	--	--	7.50	--	
	12/19/07	9:15	2.2	--	--	11.70	--	
	(13.9) ⁵	05/13/08	9:01	8.72	--	--	5.18	--
		09/03/08	--	8.74	--	--	5.16	--
		12/03/08	11:16	8.45	--	--	5.45	--
		02/17/09	9:14	7.77	Sheen	--	6.13	--
		05/12/09	9:12	7.48	--	--	6.42	--
		05/26/09	13:15	7.94	--	--	5.96	--
		09/10/09	9:44	8.95	--	--	4.95	--
		04/13/10	10:07	7.75	--	--	6.15	--
09/21/10	9:52	7.82	--	--	6.08	--		
RW-6 (13.9) ⁵	05/13/08 ⁷	8:58	8.35	--	--	5.55	--	
	09/03/08	--	8.14	--	--	5.76	--	
	12/03/08	11:13	7.95	--	--	5.95	--	
	02/17/09	9:17	7.80	--	--	6.10	--	
	05/12/09	9:10	7.57	--	--	6.33	--	
	05/26/09	13:12	7.65	--	--	6.25	--	
	09/10/09	9:43	7.90	--	--	6.00	--	
	04/13/10	10:05	7.42	--	--	6.48	--	
09/21/10	9:50	6.74	--	--	7.16	--		

Table 4
Summary of Groundwater Elevation Data

Former Unocal Seattle Marketing Terminal
3001 Elliott Avenue
Seattle, Washington

Well Number ¹ (Well Casing Elevation)	Date Measured	Time Measured (hr:min)	Depth to Groundwater ² (feet)	Depth to LNAPL ³ (feet)	LNAPL Thickness ³ (feet)	Groundwater Elevation ⁴ (feet)	Top of Well Screen Elevation ⁵ (feet)	
RW-7 (14.2) ⁵	09/13/07	--	8.75	--	--	5.45	--	
	11/01/07	11:20	9.3	--	--	4.90	--	
	11/26/07	12:07	8.1	--	--	6.10	--	
	12/07/07	11:40	6.45	--	--	7.75	--	
	12/07/07	9:10	6.4	--	--	7.80	--	
	05/13/08	8:43	8.80	--	--	5.40	--	
	09/03/08	--	8.84	--	--	5.36	--	
	12/03/08	11:11	8.60	--	--	5.60	--	
	02/17/09	9:20	8.95	--	--	5.25	--	
	05/12/09	9:08	7.41	--	--	6.79	--	
	05/26/09	13:10	7.81	--	--	6.39	--	
	08/04/09	--	8.18	--	--	6.02	--	
	09/10/09	9:40	8.83	--	--	5.37	--	
	04/13/10	10:03	7.78	--	--	6.42	--	
	09/21/10	9:47	7.88	--	--	6.32	--	
RW-8 (13.9) ⁵	09/13/07	--	8.75	--	--	5.15	--	
	11/01/07	11:25	8.9	--	--	5.00	--	
	11/26/07	12:09	7.9	--	--	6.00	--	
	12/07/07	11:35	6.07	--	--	7.83	--	
	12/19/07	9:05	7.18	--	--	6.72	--	
	05/13/08	8:39	8.59	--	--	5.31	--	
	09/03/08	--	8.53	--	--	5.37	--	
	12/03/08	11:09	8.20	--	--	5.70	--	
	02/17/09	9:24	7.70	--	--	6.20	--	
	05/12/09	9:05	7.41	--	--	6.49	--	
	05/26/09	13:07	7.59	--	--	6.31	--	
	09/10/09	9:38	8.61	--	--	5.29	--	
	04/13/10	10:00	7.39	--	--	6.51	--	
	09/21/10	9:43	7.58	--	--	6.32	--	
	RW-9 (14.1) ⁵	09/13/07	--	8.45	--	--	5.65	--
11/01/07		11:30	7.4	--	--	6.70	--	
11/26/07		12:11	7.44	--	--	6.66	--	
12/07/07		11:32	5.55	--	--	8.55	--	
12/19/07		9:00	6.15	--	--	7.95	--	
05/13/08		8:33	8.61	--	--	5.49	--	
09/03/08		--	7.38	--	--	6.72	--	
12/03/08		11:06	6.95	--	--	7.15	--	
02/17/09		9:27	6.80	--	--	7.30	--	
05/12/09		9:03	7.22	--	--	6.88	--	
05/26/09		13:04	10.06	--	--	4.04	--	
09/10/09		9:34	7.47	--	--	6.63	--	
04/13/10		9:57	8.28	--	--	5.82	--	
09/21/10		9:40	8.47	--	--	5.63	--	
RW-10 (14.3) ⁵		09/13/07	--	8.9	--	--	5.40	--
	11/01/07	11:40	8.7	--	--	5.60	--	
	11/26/07	12:12	7.89	--	--	6.41	--	
	12/07/07	11:29	6.26	--	--	8.04	--	
	12/19/07	8:55	7.25	--	--	7.05	--	
	05/13/08	8:31	8.86	--	--	5.44	--	
	09/03/08	--	8.41	--	--	5.89	--	
	12/03/08	11:03	7.87	--	--	6.43	--	
	02/17/09	9:28	7.90	--	--	6.40	--	
	05/12/09	9:01	7.47	--	--	6.83	--	
	05/26/09	13:02	8.95	--	--	5.35	--	
	09/10/09	9:32	8.58	--	--	5.72	--	
	04/13/10	9:55	7.80	--	--	6.50	--	
	09/21/10	9:38	8.12	--	--	6.18	--	
	RW-11 (14.1) ⁵	12/07/07	11:14	6.5	--	--	7.60	--
12/19/07		8:50	7.6	--	--	6.50	--	
05/13/08		8:28	8.86	--	--	5.24	--	
09/03/08		--	8.79	--	--	5.31	--	
12/03/08		11:01	8.26	--	--	5.84	--	
02/17/09		9:31	7.80	--	--	6.30	--	
05/12/09		8:59	7.64	--	--	6.46	--	
05/26/09		12:59	8.33	--	--	5.77	--	
09/10/09		9:29	8.61	--	--	5.49	--	
04/13/10		9:53	7.85	--	--	6.25	--	
09/21/10		9:35	7.98	--	--	6.12	--	
RW-12 (14.0) ⁵	12/07/07	11:08	6.78	--	--	7.22	--	
	12/19/07	8:40	7.88	--	--	6.12	--	
	05/13/08	8:25	8.97	--	--	5.03	--	
	09/03/08	--	9.02	--	--	4.98	--	
	12/03/08	10:48	8.56	--	--	5.44	--	
	02/17/09	9:33	7.85	--	--	6.15	--	
	05/12/09	8:56	7.76	--	--	6.24	--	
	05/26/09	12:55	8.37	--	--	5.63	--	
	09/10/09	9:27	9.22	--	--	4.78	--	
	04/13/10	9:50	7.93	--	--	6.07	--	
09/21/10			Unable to locate					
RW-13 (14.1) ⁵	11/26/07	12:15	8.17	--	--	5.93	--	
	12/07/07	11:05	6.83	--	--	7.27	--	
	12/19/07	8:35	7.5	--	--	6.60	--	
	05/13/08	8:22	9.01	--	--	5.09	--	
	09/03/08	--	9.05	--	--	5.05	--	
	12/03/08	10:45	8.64	--	--	5.46	--	
	02/17/09	9:36	8.22	--	--	5.88	--	
	05/12/09	8:53	7.85	--	--	6.25	--	
	05/26/09	12:53	8.48	--	--	5.62	--	
	09/10/09	9:22	8.89	--	--	5.21	--	
04/13/10	9:47	8.01	--	--	6.09	--		
09/21/10	9:30	8.15	--	--	5.95	--		
RW-14			UNABLE TO LOCATE					

Table 4
Summary of Groundwater Elevation Data

Former Unocal Seattle Marketing Terminal
3001 Elliott Avenue
Seattle, Washington

Well Number ¹ (Well Casing Elevation)	Date Measured	Time Measured (hr:min)	Depth to Groundwater ² (feet)	Depth to LNAPL ³ (feet)	LNAPL Thickness ³ (feet)	Groundwater Elevation ⁴ (feet)	Top of Well Screen Elevation ⁵ (feet)	
RW-15 (13.9) ⁶	09/13/07	--	8.83	--	--	5.07	--	
	11/01/07	11:50	9	--	--	4.90	--	
	11/26/07	12:18	8.4	--	--	5.50	--	
	12/07/07	10:56	6.55	--	--	7.35	--	
	12/19/07	8:25	6.31	--	--	7.59	--	
	05/13/08	8:17	8.97	--	--	4.93	--	
	09/03/08	--	8.52	--	--	5.38	--	
	12/03/08	10:40	8.31	--	--	5.59	--	
	02/17/09	9:44	8.24	--	--	5.66	--	
	05/12/09	8:50	8.19	--	--	5.71	--	
	05/26/09	12:48	8.25	--	--	5.65	--	
	09/10/09	9:20	5.52	--	--	8.38	--	
	04/13/10	9:45	7.88	--	--	6.02	--	
		09/21/10			Unable to locate			
RW-21 (5.87) (15.3) ⁶	09/13/07	--	9.85	Sheen	--	-3.98	--	
	11/01/07	10:35	9.90	7.90	2.00	-2.43	--	
	11/26/07	12:23	--	Sheen	--	--	--	
	12/07/07	9:40	6.90	Sheen	--	-1.03	--	
	12/19/07	--	7.79	--	--	-1.92	--	
	01/03/07	9:25	7.88	--	--	-2.01	--	
	01/30/07	8:44	8.67	--	--	-2.80	--	
	02/12/08	9:11	8.80	--	--	-2.93	--	
	03/03/08	9:10	9.25	--	--	-3.38	--	
	03/17/08	9:07	9.21	--	--	-3.34	--	
	04/01/08	9:05	9.09	--	--	-3.22	--	
	04/14/08	8:55	9.32	--	--	-3.45	--	
	04/28/08	9:24	9.33	--	--	-3.46	--	
		05/13/08			Unable to Access			
		05/27/08	11:20	9.45	--	--	5.85	--
		06/10/08	10:45	9.21	--	--	6.09	--
		06/24/08	9:29	9.49	--	--	5.81	--
		07/07/08	9:39	9.19	--	--	6.11	--
		07/22/08	9:00	9.38	--	--	5.92	--
		08/12/08	9:36	9.35	--	--	5.95	--
		09/03/08	--	9.36	Sheen	--	5.94	--
		10/08/08	8:30	9.72	Sheen	--	5.58	--
		10/17/08	8:41	9.50	--	--	5.80	--
		10/29/08	8:31	9.58	--	--	5.72	--
		11/12/08	9:27	7.83	--	--	7.47	--
		12/03/08	10:10	9.22	9.20	0.02	6.10	--
		01/06/09	9:26	7.89	Sheen	--	7.41	--
		01/20/09	12:29	8.56	8.55	0.01	6.75	--
		02/03/09	9:24	9.20	Sheen	--	6.10	--
		02/17/09	9:50	9.05	Sheen	--	6.25	--
		03/12/09	11:31	9.16	Sheen	--	6.14	--
		03/25/09	9:24	9.01	Sheen	--	6.29	--
		04/08/09	9:57	8.91	8.90	0.01	6.40	--
		04/30/09	9:49	8.88	Sheen	--	6.42	--
	05/12/09	9:43	8.45	8.44	0.01	6.86	--	
	05/26/09	14:48	8.82	--	--	6.48	--	
	06/09/09	9:26	8.64	--	--	6.66	--	
	06/25/09	9:29	8.68	--	--	6.62	--	
	07/07/09	9:26	8.95	Sheen	--	6.35	--	
	07/13/09	8:05	9.45	--	--	5.85	--	
	08/05/09	6:45	8.96	Sheen	--	6.34	--	
	08/06/09	9:18	9.06	--	--	6.24	--	
	08/20/09	8:34	9.15	--	--	6.15	--	
	09/10/09	9:57	9.28	--	--	6.02	--	
	09/23/09	9:21	9.25	Sheen	--	6.05	--	
	10/08/09	9:16	9.31	Sheen	--	5.99	--	
	10/19/09	9:50	9.23	Sheen	--	6.07	--	
	11/12/09	9:19	7.82	Sheen	--	7.48	--	
	03/24/10	9:37	8.62	Sheen	--	6.68	--	
	04/13/10	10:19	8.61	Sheen	--	6.69	--	
	05/26/10	9:32	8.73	Sheen	--	6.57	--	
	09/21/10	10:05	8.46	Sheen	--	6.84	--	
	11/19/10	16:01	9.21	Sheen	--	6.09	--	

Notes:

¹Well casing elevations listed in feet above mean sea level. Approximate monitoring well locations are shown in Figure 2.

²Below top of casing.

³Light non-aqueous phase liquid

⁴Elevation referenced to city of Seattle datum.

⁵Top of well screen elevation data from historic records.

⁶TOC elevations for wells MW-200 to 207, MW-27R, and MW-61A-R were surveyed using an arbitrary datum point, 9.65 feet lower than the datum from the upper well survey.

⁷Depth to water was measured with pump in well.

⁸Survey by OTAK 5/27/08.

⁹Groundwater elevation recorded prior to pump testing at the site. Sheen observed on extracted groundwater during hydraulic conductivity testing on well MW-205.

NR = Not reported

Bolded data are for the current reporting period.

"--" = not measured or not obtainable

Table 5
Summary of Groundwater Compliance as of Second Semi-annual 2010

Former Unocal Seattle Marketing Terminal
 3001 Elliott Avenue
 Seattle, Washington

Monitoring Well	Petroleum Constituents and Sheen (BTEX, Gasoline-range, Diesel-range)		cPAHs		Lead	
	Current Sampling Interval	Consecutive Sampling Events in Compliance ¹	Current Sampling Interval	Consecutive Sampling Events in Compliance ¹	Current Sampling Interval	Consecutive Sampling Events in Compliance ¹
Upper Yard						
MW-61A-R	semi-annually	0	none	N/A	none	N/A
Elliott Avenue						
MW-30	semi-annually	1	none	N/A	none	N/A
Offsite Area- Amendment No. 4 Point of Compliance monitoring wells						
MW-200	semi-annually	1 ⁷	semi-annually ²	13 ^{4,5}	semi-annually ²	12
MW-201	semi-annually	1 ⁷	semi-annually ²	8 ³	semi-annually ²	12
MW-202	semi-annually	13	semi-annually ²	10 ³	semi-annually ²	12
MW-203	semi-annually	13	semi-annually ²	13 ⁴	semi-annually ²	12
MW-204	semi-annually	0	semi-annually ²	13 ⁴	semi-annually ²	12
MW-205	semi-annually	1 ⁸	semi-annually ²	13 ⁴	semi-annually ²	12
MW-206	semi-annually	13	semi-annually ²	13 ^{4,6}	semi-annually ²	12
MW-207	semi-annually	13	semi-annually ²	13 ^{4,6}	semi-annually ²	12

Notes:

¹ "Consecutive events" are number of consecutive sampling events prior to and including the current reporting period that are in compliance with the groundwater remediation action levels. Events prior to 3/97 are not counted. Refer to progress reports for results.

² Quarterly sampling beginning June 2007. Semi-annual sampling beginning 2010.

³ Field-Filtered sample below RAL.

⁴ Field-Filtered and Un-Filtered samples below RAL.

⁵ 9/3/08 laboratory reporting limit above RAL.

⁶ Confirmation samples indicate erroneous 9/4/08 field-filtered data.

⁷ Sheen noted on groundwater during well redevelopment.

⁸ Sheen noted on tubing in well during hydraulic conductivity testing.

BTEX = benzene, toluene, ethylbenzene, xylenes

cPAHs = carcinogenic polynuclear aromatic hydrocarbons

N/A = not applicable

Table 6
Summary of Geochemical Parameter Field Data

Former Unocal Seattle Marketing Terminal
 3001 Elliott Avenue
 Seattle, Washington

Monitoring Well	Date Sampled	pH	Specific Conductivity (µS/cm)	Temperature (degrees Celsius)	DO (mg/L)	ORP (mV)	Turbidity (NTUs)	Notes
<i>Elliott Avenue Area</i>								
MW-30	4/14/2010	6.84	608	12.75	0.09	-79	19.3	1
<i>Offsite Area</i>								
MW-200	4/14/2010	7.12	1,933	15.02	0.23	-117	8.5	1
MW-201	4/14/2010	6.86	960	15.28	0.25	-54	31.1	1
MW-202	4/14/2010	7.05	22,382	12.30	0.22	-135	16.1	
MW-203	4/14/2010	7.08	18,193	14.26	0.64	-81	284	
MW-204	4/14/2010	6.87	499	14.03	0.04	-99	940	
MW-205	4/14/2010	7.35	513	14.30	0.21	-113	17.5	1
MW-206	4/13/2010	6.93	15,788	12.86	0.09	-157	22.4	
MW-207	4/13/2010	7.00	23,604	13.39	1.48	-218	7.0	1

Notes:

¹: Turbidity data inconsistent, Most recent positive data entered in table.

µS/cm = microSeimens per centimeter

mg/L = milligrams per liter

NTUs = Nephelometric turbidity units

DO = Dissolved oxygen

ORP = Oxidation-reduction potential

Table 7
Summary of Geochemical Parameter Analytical Data

Former Unocal Seattle Marketing Terminal
3001 Elliott Avenue
Seattle, Washington

Monitoring Well	Date Sampled	Sulfate (mg/L)	Sulfide (mg/L)	Nitrate as Nitrogen (mg/L)	Nitrate (Colorimetric Field Kit) (mg/L)	Manganese (6020) (mg/L)	Dissolved Manganese (6020) (mg/L)	Iron (Colorimetric Field Kit) (mg/L)	Iron (6020) (mg/L)	Dissolved Iron (6020) (mg/L)	Alkalinity (mg/L)	Methane (RSK-175) (ug/L)	Carbon Dioxide (RSK-175) (ug/L)	Ammonia (mg/L)	Ethane (RSK-175) (ug/L)	Ethylene (RSK-175) (ug/L)	Total Organic Carbon (mg/L)
Elliott Avenue Area																	
MW-30	4/14/2010	180	3.3	<0.90	<5	0.52	0.51	3.2	2.8	2.7	220	260	630	0.31	<1.0	<1.0	5.9
Offsite Area																	
MW-200	4/14/2010	21	<1.0	<0.90	<5	0.54	0.56	1.4	1.0	1.0	320	4,100	340	2.0	<10	<10	4.7
MW-201	4/14/2010	5.3	<1.0	<0.90	<5	0.23	0.24	1	0.50	0.52	280	5,100	610	0.34	<10	<10	5.0
MW-202	4/14/2010	930	1.3	<0.90	<5	0.11	0.12	0	<0.20	<0.20	310	850	350	0.31	<10	<10	4.4
MW-203	4/14/2010	890	<1.0	<0.90	<5	0.24	0.26	1	0.44	0.48	300	360	290	0.57	<10	<10	4.8
MW-204	4/14/2010	<1.2	<1.0	<0.90	<5	0.84	0.87	5	4.0	3.9	230	3,300	710	0.93	<5.0	<5.0	6.1
	4/14/2010 ^D	<1.2	4.1	<0.90	--	0.83	0.85	--	3.9	4.0	240	3,300	670	1.1	<10	<10	5.1
MW-205	4/14/2010	7.5	<1.0	<0.90	<5	0.93	1.0	1	0.49	0.53	270	1,600	2,700	3.5	<1.0	<1.0	3.1
MW-206	4/13-14/2010	1,800	1.1	<0.90	<5	0.24	0.34	1	0.66	0.53	170	120	210	0.95	<1.0	<1.0	2.2
MW-207	4/13-14/2010	1,400	<1.0	<0.90	<5	0.041	0.041	2.6	<0.20	<0.20	230	780	740	<0.10	<5.0	<5.0	2.4

Notes:

mg/L = milligrams per liter

ug/L = micrograms per liter

< = Indicates concentration not detected above the analytical method reporting limit.

D = Duplicate sample

-- = Data not collected

Table 8
Summary of Piezometer Installation Soil Analytical Data

Former Unocal Seattle Marketing Terminal
 3001 Elliott Avenue
 Seattle, Washington

Piezometer ID	Sample Depth	Sample Date	Gasoline Range Organics (mg/kg) ³	Diesel Range Organics (mg/kg) ⁴	Heavy Oils (mg/kg) ⁴
MTCA Method A Cleanup Level¹			30³	2,000	2,000
PZ-61A-R	9.0	06/04/10	<5.7	<27	<53
	19.5	06/04/10	43	<27	<54
PZ-203	5.0	06/29/10	<7.9	<24	150
	10.0	06/29/10	<7.9	<25	180
	15.0	06/29/10	55	130	180
	20.0	06/29/10	19	41	68
PZ-204	5.0	06/01/10	<8.4	<24	<48
	10.0	06/29/10	<8.0	<25	<50
	15.0	06/29/10	<7.4	<26	<52
	19.0	06/29/10	3,200	2,600	820
	25.0	06/29/10	1,300	2,100	360
	29.5	06/29/10	310	<28	<56
	35.0	06/29/10	67	<30	<60

Notes:

¹MTCA Method A Cleanup Levels for Unrestricted Land Use used for reference. Site-specific soil cleanup levels not established in Order On Consent DE 88-N223 for the Offsite area.

²Gasoline mixture with benzene assumed due to benzene concentrations in groundwater.

³Analyzed by analytical method NWTPH-G.

⁴Analyzed by analytical method NWTPH-Dx.

mg/kg = milligrams per kilogram

"<" = Indicates concentration not detected above method reporting limit

Highlighted data exceeds MTCA Method A Cleanup Levels for Unrestricted Land Use.

MTCA = Model Toxics Control Act

mg/kg = milligrams per kilogram

Table 9
Summary of Piezometer and Monitoring Well Development and Redevelopment Activities

Former Unocal Seattle Marketing Terminal
 3001 Elliott Avenue
 Seattle, Washington

Well Developed	Volume Purged (gallons)	Notes/Observations ¹
<i>New Piezometers</i>		
PZ-203	6.3	Water clear at 4.2 gal, resurged fro 2 minutes, water clear again at 5.8 gal
PZ-204	9.5	Very silty after 5 gal purged, remained turbid at 9.5 gal purged, light TPH odor, headspace PID = 0.0 ppmv
PZ-61A-R	28	Water clear
<i>Existing Monitoring Wells</i>		
MW-200	7	Sheen observed, headspace PID = 0.0 ppmv
MW-201	3	Sheen observed, TPH odor, headspace PID = 0.0 ppmv
MW-202	7	
MW-203	6	Water cleared quickly at approximately 4.5 gallons purged
MW-205	5	PID = 0.0 ppmv
MW-206	10	PID = 0.0 ppmv
MW-207	10	

Notes:

¹: Observations of "silty", "clear" or turbid" made visually.

gal = gallons

ppmv = parts per million by volume

TPH = total petroleum hydrocarbons

Table 10
Summary of Surfactant Monitoring Data

Former Unocal Seattle Marketing Terminal
3001 Elliott Avenue
Seattle, Washington

Well Number ¹ (Well Casing Elevation)	Date Measured	Time Measured (hr:min)	Depth to Groundwater ² (feet)	Depth to LNAPL (feet)	LNAPL Thickness (feet)	Groundwater Elevation (feet)	Specific Conductivity (uS/cm-°C) ^{4,5}	Notes
Surfactant Solution							589	
MW-30 22.85	04/13/10	10:31	12.98	--	--	9.87	608	Thick black LNAPL on probe
	05/26/10	9:15	13.36	--	--	9.49	--	Trace LNAPL on probe
	07/20/10	11:14	--	--	--	--	1,053	Pre-Injection
	07/21/10	10:16	14.00	--	--	8.85	1,040	Pre-Extraction
	07/28/10	14:40	14.11	--	--	8.74	1,026	Clear Sample
	08/05/10	11:49	14.10	--	--	8.75	1,081	Clear
	08/13/10	10:10	13.90	--	--	8.95	--	Clear
	08/13/10	10:15	--	--	--	--	1,110	Clear
	08/18/10	8:36	13.92	--	--	8.93	949	--
	09/21/10	10:29	13.3	--	--	9.55	--	--
	09/23/10	9:45	13.47	--	--	9.38	--	--
	10/11/10	11:01	13.40	--	--	9.45	833	Little to no suds
	11/19/10	14:54	12.41	--	--	10.44	549	LNAPL on probe, no suds
MW-61A-R 22.44	04/13/10	10:37	13.06	12.95	0.11	9.38	NR	LNAPL in well
	05/26/10	9:15	13.91	13.76	0.15	8.53	NR	LNAPL in well
	07/20/10	9:47	14.66	14.61	0.05	7.78	NR	Pre-Injection
	07/20/10	11:04	--	--	--	--	1,232	Pre-Injection
	07/20/10	13:05	--	--	--	--	994	197-gal injected
	07/21/10	9:47	14.66	--	--	7.78	NR	Post-Injection
	07/21/10	10:03	--	--	--	--	980	Pre-Extraction
	07/21/10	10:32	--	--	--	--	934	In well measurement
	07/21/10	11:10	--	--	--	--	968	150-gal extracted
	07/21/10	11:26	--	--	--	--	830	In well measurement
	07/21/10	12:00	--	--	--	--	844	In well measurement
	07/21/10	12:02	--	--	--	--	950	300-gal extracted
	07/21/10	12:44	--	--	--	--	885	In well measurement
	07/21/10	12:45	--	--	--	--	964	450-gal extracted
	07/21/10	13:22	--	--	--	--	973	600-gal extracted
	07/21/10	13:27	--	--	--	--	910	In well measurement
	07/21/10	14:00	--	--	--	--	963	In well measurement
	07/21/10	14:00	--	--	--	--	909	750-gal extracted
	07/21/10	14:33	--	--	--	--	954	In well measurement
	07/21/10	14:52	--	--	--	--	920	In well measurement
	07/21/10	15:00	--	--	--	--	960	900-gal extracted
	07/28/10	14:56	14.78	--	--	7.66	972	Clear Sample
	08/05/10	11:28	14.79	--	--	7.65	610	Black Precipitate
	08/13/10	9:32	--	--	--	--	600	Clear, No LNAPL
	08/13/10	9:38	13.62	--	--	8.82	--	Clear
	08/18/10	8:55	14.70	--	--	7.74	529	No LNAPL
	09/21/10	10:42	15.35	--	--	7.09	--	--
	09/23/10	10:30	14.25	--	--	8.19	--	--
	10/11/10	11:20	14.35	14.31	0.04	8.09	459	No suds, LNAPL present
	11/19/10	15:25	13.30	13.19	0.11	9.14	--	LNAPL present

Table 10
Summary of Surfactant Monitoring Data

Former Unocal Seattle Marketing Terminal
3001 Elliott Avenue
Seattle, Washington

Well Number ¹ (Well Casing Elevation)	Date Measured	Time Measured (hr:min)	Depth to Groundwater ² (feet)	Depth to LNAPL (feet)	LNAPL Thickness (feet)	Groundwater Elevation (feet)	Specific Conductivity (uS/cm-°C) ^{4,5}	Notes
PZ-61A-R ³	07/20/10	10:30	14.50	--	--	--	--	--
	07/20/10	11:06	--	--	--	--	934	Pre-Injection
	07/20/10	11:32	--	--	--	--	2,932	In well measurement
	07/20/10	12:45	--	--	--	--	987	170-gal injected
	07/20/10	12:50	--	--	--	--	1,082	197-gal injected
	07/20/10	12:52	--	--	--	--	1,082	--
	07/21/10	10:04	--	--	--	--	885	Pre-Extraction
	07/21/10	10:05	14.51	--	--	--	--	--
	07/21/10	10:32	--	--	--	--	885	In well measurement
	07/21/10	11:25	--	--	--	--	991	150-gal extracted
	07/21/10	11:26	--	--	--	--	881	In well measurement
	07/21/10	12:00	--	--	--	--	729	In well measurement
	07/21/10	12:06	--	--	--	--	1,000	300-gal extracted
	07/21/10	12:44	--	--	--	--	860	In well measurement
	07/21/10	12:48	--	--	--	--	981	450-gal extracted
	07/21/10	13:25	--	--	--	--	1,040	600-gal extracted
	07/21/10	13:27	--	--	--	--	840	In well measurement
	07/21/10	14:00	--	--	--	--	850	In well measurement
	07/21/10	14:02	--	--	--	--	1,094	750-gal extracted
	07/21/10	14:33	--	--	--	--	860	In well measurement
	07/21/10	14:52	--	--	--	--	855	In well measurement
	07/21/10	15:00	--	--	--	--	1,022	900-gal extracted
	07/28/10	14:58	14.61	--	--	--	1,240	Clear Sample
	08/05/10	11:20	14.61	--	--	--	568	Clear
	08/13/10	9:40	13.44	--	--	--	--	Clear
	08/13/10	9:45	--	--	--	--	724	--
08/18/10	8:44	14.47	--	--	--	498	--	
09/21/10	10:36	14.05	--	--	--	--	--	
09/28/10	8:56	14.04	--	--	--	390	-- ⁶	
10/11/10	11:12	14.18	--	--	--	437	--	
11/19/10	15:15	12.89	--	--	--	384	No suds	

Notes:

¹Well casing elevations listed in feet above mean sea level. Approximate monitoring well locations are shown in Figure 2.

²Below top of casing.

³PZ-61A-R not surveyed.

⁴Specific conductivity measurements taken with a YSI-556 water quality meter.

⁵Specific conductivity measurements taken from shake samples unless otherwise noted.

⁶Conductivity measured instead of specific conductivity.

LNAPL = Light non-aqueous phase liquid

hr:min = hours: minutes

uS/cm-°C = microSiemens per centimeter normalized to 25 degrees Celsius

gal = gallons

**Table 11
Summary of Hydraulic Conductivity Testing Activities**

Former Unocal Seattle Marketing Terminal
3001 Elliott Avenue
Seattle, Washington

Test Well	Type of Test	Date of Test	Target Tide Stage	Wells Monitored	Tidal Influence Correction (ft/s)	Pressure Transducer Data Collection Interval** (s)	Data Usable?	Comments
MW-30	CR	8/13/2010	High	MW-30 (pumping well)	--*	--	Yes	Transient background groundwater elevation trend noted in observation well MW-61A-R. Groundwater drawdown corrected by 3.8E-05 ft/s. No measurable drawdown in observation well
				MW-61A-R (observation well)	--	60	No	
MW-61A-R	CR	8/13/2010	High	MW-61A-R (pumping well)	--	--	Yes	--***
				PZ-61A-R (observation well)	--	60	Yes	--***
				MW-30 (observation well)	--	60	No	No measurable drawdown in observation well
MW-200	CR	9/14/2010	High	MW-200 (pumping well)	3.0E-05*	--	Yes	--
				MW-201 (observation well)	3.0E-05*	10	Yes	--
MW-201	CR	9/15/2010	High	MW-201 (pumping well)	5.0E-05*	--	Yes	--
				MW-200 (observation well)	5.0E-05*	10	Yes	--
MW-202	CR	9/17/2010	High	MW-202 (pumping well)	4.0E-05*	--	Yes	--
				MW-201 (observation well)	--	10	No	No measurable drawdown in observation well
MW-203	CR	8/12/2010	High	MW-203 (pumping well)	--	--	No	Insufficient drawdown in pumping well
				MW-204 (observation well)	--	60	No	No measurable drawdown in observation well
MW-203	CR	9/2/2010	High	MW-203 (pumping well)	--	--	No	Problems with pump, could not maintain CR
				MW-204 (observation well)	--	15	No	Problems with pump, could not maintain CR
				PZ-203 (observation well)	--	15	No	Problems with pump, could not maintain CR
MW-203	CR	9/14/2010	High	MW-203 (pumping well)	--	--	No	Tidal influence correction could not be quantified, data could not be corrected
				PZ-203 (observation well)	--	60	No	No measurable drawdown in observation well
MW-204	CR	8/12/2010	High	MW-204 (pumping well)	-9.0E-05*	--	Yes	--
				MW-203 (observation well)	--	60	No	No measurable drawdown in observation well
				PZ-204 (observation well)	-9.0E-05*	60	Yes	--
MW-204	CR	9/16/2010	Low	MW-204 (pumping well)	9.0E-05*	--	Yes	--
				PZ-204 (observation well)	9.0E-05*	10	Yes	--
MW-205	CR	9/17/2010	High	MW-205 (pumping well)	7.0E-05*	--	Yes	--
				MW-204 (observation well)	7.0E-05*	10	Yes	--
MW-206	CR	9/17/2010	High	MW-206 (pumping well)	6.3E-05*	--	Yes	--
				MW-202 (observation well)	--	10	No	No measurable drawdown in observation well
MW-207	CR	8/16/2010	High	MW-207 (pumping well)	2.0E-05*	--	Yes	--
				MW-205 (observation well)	--	60	No	No measurable drawdown in observation well
				MW-206 (observation well)	--	60	No	No measurable drawdown in observation well
RW-3	CR	8/16/2010	High	RW-3 (pumping well)	--	--	No	Pumping rate too high, pumping well dewatered after 3 minutes
				RW-2 (observation well)	--	15	No	Pumping rate too high, pumping well dewatered after 3 minutes
RW-3	CR	9/2/2010	High	RW-3 (pumping well)	--	15	Yes	--
				RW-2 (observation well)	--	15	No	No measurable drawdown in observation well
RW-21	CR	9/3/2010	High	RW-21 (pumping well)	--*	15	Yes	Transient background groundwater elevation trend noted in pumping well by pre and post test monitoring. Groundwater drawdown corrected by -5E-05 ft/s.

Notes:

gpm = gallons per minute

CR = constant rate

ft/s = feet per second

s = seconds

* Background water levels were evaluated to obtain the rate of change per time; corrections were made to observed drawdown where appropriate

** Pressure transducers deployed in observation wells only (except for RW-3 and RW-21)

*** The datasets for this test indicated the presence of a potential recharge boundary or soil heterogeneity and results should be used with caution.

Table 12
Summary of Hydraulic Conductivity Testing Results

Former Unocal Seattle Marketing Terminal
3001 Elliott Avenue
Seattle, Washington

Test Well	Type of Test	Date of Test	Pumping Rate (gpm)	Observation Well(s)	Target Tidal Stage	Well Diameter (ft)	Saturated Thickness (ft)	Maximum Drawdown During Pumping (ft)	Max Drawdown / Saturated Thickness	Transmissivity (ft ² /d)	Hydraulic Conductivity (ft/d)	Storativity
MW-30	CR	8/13/2010	3.1 -4.1	MW-30	NA	0.33	17.1	12.1	71%	29	1.7	--
MW-61A-R	CR	8/13/2010	4.2	MW-61A-R	NA	0.17	17.3	4.9	28%	160	9.2	--
				PZ-61A-R		0.17		2.0	11%	75	4.3	0.01
MW-200	CR	9/14/2010	4.5	MW-200	High	0.17	14.6	1.1	8%	570	39	--
				MW-201		0.17		0.4	3%	330	23	0.006
MW-201	CR	9/15/2010	6.0	MW-201	High	0.17	14.3	4.8	33%	250	17	--
				MW-200		0.17		0.6	4%	360	25	0.004
MW-202	CR	9/17/2010	5.2	MW-202	High	0.17	9.0	0.7	8%	1,300	140	--
MW-204	CR (Test 1)	8/12/2010	5.6	MW-204	High	0.17	13.0	5.5	42%	110	8.4	--
				PZ-204		0.17		2.0	15%	110	8.4	0.02
MW-204	CR (Test 2)	9/16/2010	5.4	MW-204	Low	0.17	11.1	4.7	43%	160	14	--
				PZ-204		0.17		2.2	20%	120	11	0.02
MW-205	CR	9/17/2010	4.9	MW-205	High	0.17	23.9	5.4	23%	150	6.3	--
				MW-204		0.17		0.2	1%	970	41	0.01
MW-206	CR	9/17/2010	5.5	MW-206	High	0.17	8.7	0.5	5%	3,700	430	--
MW-207	CR	8/16/2010	5.0	MW-207	High	0.17	14.2	0.7	5%	2,800	200	--
RW-3	CR	9/2/2010	0.4	RW-3	High	0.33	9.2	4.0	44%	4.5	0.5	--
RW-21	CR	9/3/2010	1.1	RW-21	NA	0.33	14.5	12.9	89%	4.0	0.3	--

Notes:

"Test Well" indicates which well was pumped.

CR = constant rate.

Observation wells includes pumping wells, as appropriate.

Saturated thickness calculated from pre-pumping static groundwater level.

NA = Not applicable

ft = feet

gpm = gallons per minute

ft² / d = feet squared per day

Hydraulic conductivity and transmissivity values rounded to two significant figures after analysis

ft/d = feet per day

Transmissivity and storativity, where appropriate, calculated using the Theis (1935) non-equilibrium well equation.

Hydraulic Conductivity = Transmissivity / Saturated Thickness

Storativity calculated for non-pumping wells only.

Table 13
Summary of Hydraulic Conductivity, Average Linear Groundwater Velocity and Travel Time

Former Unocal Seattle Marketing Terminal
 3001 Elliott Avenue
 Seattle, Washington

Well	Gradient to Puget Sound (ft/ft)	K Values (ft/day)	Geometric Mean of the Native Fill K Values (ft/day) ¹	Linear Groundwater Velocity (ft/day)	Average Linear Groundwater Velocity (ft/day)	Distance Between Well and Seawall (ft)	Groundwater Travel Time from Well to Sea Wall (d)
MW-200	0.011	39	12	0.7	1.0	58	55.9
MW-201	0.012	17		0.7		60	57.8
MW-202	0.023	140 ²		1.4		32	30.8
MW-203	0.010	NA		0.6		70	67.4
MW-204 (high)	0.014	8.4		0.9		72	69.4
MW-204 (low)	0.014	14		0.9		72	69.4
MW-205	0.014	6.3		0.9		74	71.3
MW-206	0.031	430		1.9		22	21.2
MW-207	0.031	200		1.9		20	19.3
RW-3	0.014	0.5		0.9		96	92.5
RW-21	0.012	0.3		0.7		152	146.4
			Minimum Average Linear Groundwater Velocity (ft/day)	0.6			
			Maximum Average Linear Groundwater Velocity (ft/day)	1.9			

Notes:

- 1: Geometric mean calculated using only pumping well K-values from the Offsite Area native fill geologic formation.
- 2: K-value representative of 2005 "hot-spot" excavation and not included in geometric mean calculation.

K-values = Hydraulic conductivity values
 NA = Not applicable
 ft = feet
 ft/ft = foot per foot
 ft/day = feet per day
 d = day

**Table 14
Summary of COC Chemical Properties**

Former Unocal Seattle Marketing Terminal
3001 Elliott Avenue
Seattle, Washington

COC	Soil Organic Carbon-Water Partitioning Coefficient (K_{oc}) (mL/g)	Reference	Retardation Factor	First-Order Kinetics Rate Constant (day^{-1})	Reference	Anaerobic Half-Life in Groundwater (days)
TPH-G	800	MTCA ¹	4.76	0.016	SRC (SO ₄) ^{4,5}	43
TPH-D	5,010	MTCA ¹	24.5	0.016	SRC (SO ₄) ^{4,5}	43
TPH-O	126,000	MTCA ¹	593	0.016	SRC (SO ₄) ^{4,5}	43
Benzene	62	MTCA ²	1.29	0.016	SRC (SO ₄) ⁵	43
Toluene	140	MTCA ²	1.66	0.049	SRC (SO ₄) ⁵	14
Ethylbenzene	204	MTCA ²	1.96	0.098	SRC (SO ₄) ⁵	7
o-xylene	241	MTCA ²	2.13	0.065	SRC (SO ₄) ⁵	11
m-xylene	196	MTCA ²	1.92	0.091	SRC (SO ₄) ⁵	8
p-xylene	311	MTCA ²	2.46	0.079	SRC (SO ₄) ⁵	9
Benzo(a)anthracene	357,537	MTCA ²	1,681	0.0004	Rothermich ⁶	1,733
Benzo(a)pyrene	968,774	MTCA ²	4,554	0.0009	Rothermich ⁶	770
Benzo(b)fluoranthene	549,541	VLEACH ³	2,584	0.0006	Rothermich ⁶	1,155
Benzo(k)fluoranthene	549,541	VLEACH ³	2,584	0.0004	Rothermich ⁶	1,733
Chrysene	199,526	VLEACH ³	939	0.0009	Rothermich ⁶	770
Dibenzo(a,h)anthracene	1,789,101	MTCA ²	8,410	0.0004	Estimated from Rothermich ⁷	1,733
Indeno(1,2,3-cd)pyrene	1,584,893	VLEACH ³	7,450	0.0004	Estimated from Rothermich ⁷	1,733

Mobile porosity	0.2 estimated	
Total porosity	0.4 estimated	
Soil organic carbon fraction	0.001 unitless	Estimated from MTCA
Soil dry bulk density	1.88 kg/L	Estimated from soil sample from 17.3-17.5 feet bgs in boring PZ-61A-R.

Notes:

- 1: Chemical composition of TPH not quantified. The lowest K_{oc} value presented in MTCA Table 747-4 used for the calculation.
- 2: K_{oc} value presented in MTCA Table 747-1.
- 3: K_{oc} values referenced in the VLEACH version 2.2 manual.
- 4: First-order rate constant for TPH ranges estimated to be equivalent to benzene.
- 5: First-order rate constants from SRC, 1997. Biodegradation assumed to be sulfate reducing based on geochemical parameter data.
- 6: First-order rate constant calculated from data presented in Rothermich, Hayes and Lovley, 2002.
- 7: First-order rate constant not found in the literature. Values assumed to be equivalent to benzo(a)anthracene. See note #6.

COC = Constituent of concern
mL/g = milliliters per gram
ft/day = feet per day
ft = feet
 day^{-1} = per day
 $\mu\text{g/L}$ = micrograms per liter
 m^2 = square meters
 m^3/day = cubic meter per day
lbs/day = pounds per day
lbs/yr = pounds per year
kg/L = kilograms per liter
MTCA = Model Toxics Control Act
SO₄ = sulfate

Table 15
Estimated Groundwater and COC Discharge to Puget Sound

Former Unocal Seattle Marketing Terminal
3001 Elliott Avenue
Seattle, Washington

Well	COC	Distance from Well to Seawall (ft)	COC Travel Time from Well to Seawall (days)	Peak COC Concentration in Well from May 2009 to October 2010 (µg/L)	Predicted COC Concentration at Sea Wall (µg/L)	Surface Water Criteria for Consumption of Organisms (µg/L)	Site Groundwater RAL (µg/L)	Estimated Area of Flux (m ²)	Flux of Groundwater from the Site to Puget Sound (gpd)	Flux of COC from the Site to Puget Sound (lbs/yr)	Flux of COC from the Site to Puget Sound (mL/yr)	Notes
MW-200	TPH-G	58	276	513	6.2	NE	1,000	229	2,510	9.8E-03	6.6	1
MW-201	TPH-G	60	286	430	4.5	NE	1,000	229	2,510	7.0E-03	4.8	1
MW-202	TPH-G	32	152	233	20	NE	1,000	229	2,510	0.032	22	1
MW-203	TPH-G	70	333	82	0.40	NE	1,000	229	2,510	6.3E-04	0.42	1
MW-204	TPH-G	72	343	1,500	6.2	NE	1,000	229	2,510	9.8E-03	6.6	1
MW-205	TPH-G	74	352	100	0.36	NE	1,000	229	2,510	5.6E-04	0.38	1
MW-200	TPH-D	58	1,424	560	7.2E-08	NE	10,000	229	2,510	1.1E-10	6.7E-08	2
MW-201	TPH-D	60	1,473	470	2.7E-08	NE	10,000	229	2,510	4.3E-11	2.5E-08	2
MW-204	TPH-D	72	1,767	1,500	7.9E-10	NE	10,000	229	2,510	1.2E-12	7.3E-10	2
MW-204	TPH-O	72	42,710	840	1.4E-294	NE	15,000	229	2,510	2.2E-297	1.3E-294	3
MW-200	Benzene	58	75	3.43	1.0	51	40	229	2,510	1.6E-03	0.84	
MW-201	Benzene	60	77	2.42	0.70	51	40	229	2,510	1.1E-03	0.57	
MW-204	Benzene	72	93	1.93	0.44	51	40	229	2,510	6.9E-04	0.36	
MW-204	Toluene	72	119	2.1	0.0061	15,000	14,300	229	2,510	9.5E-06	5.0E-03	
MW-200	Ethylbenzene	58	114	1.12	1.6E-05	2,100	1,400	229	2,510	2.6E-08	1.3E-05	
MW-200	o-xylene	58	124	0.64	2.1E-04	NE	4,400	229	2,510	3.3E-07	1.7E-04	4
MW-200	m-xylene	58	111	0.64	2.5E-05	NE	4,400	229	2,510	4.0E-08	2.1E-05	4
MW-200	p-xylene	58	143	0.64	8.1E-06	NE	4,400	229	2,510	1.3E-08	6.6E-06	4
MW-201	o-xylene	60	128	0.59	1.4E-04	NE	4,400	229	2,510	2.3E-07	1.2E-04	4
MW-201	m-xylene	60	115	0.59	1.6E-05	NE	4,400	229	2,510	2.6E-08	1.3E-05	4
MW-201	p-xylene	60	148	0.59	5.1E-06	NE	4,400	229	2,510	8.0E-09	4.1E-06	4
MW-204	o-xylene	72	154	2.6	1.2E-04	NE	4,400	229	2,510	1.9E-07	9.7E-05	4
MW-204	m-xylene	72	138	2.6	8.8E-06	NE	4,400	229	2,510	1.4E-08	7.2E-06	4
MW-204	p-xylene	72	177	2.6	2.1E-06	NE	4,400	229	2,510	3.4E-09	1.7E-06	4
MW-200	Benzo(a)anthracene	58	97,523	0.013	1.5E-19	0.018	0.03	229	2,510	2.3E-22	8.9E-20	
MW-201	Benzo(a)anthracene	60	100,885	0.026	7.8E-20	0.018	0.03	229	2,510	1.2E-22	4.7E-20	
MW-202	Benzo(a)anthracene	32	53,806	0.049	2.2E-11	0.018	0.03	229	2,510	3.5E-14	1.3E-11	
MW-201	Chrysene	60	56,326	0.030	2.9E-24	0.018	0.03	229	2,510	4.6E-27	1.6E-24	
MW-202	Chrysene	32	30,041	0.047	8.5E-14	0.018	0.03	229	2,510	1.3E-16	4.8E-14	
MW-204	Chrysene	72	67,592	0.019	7.4E-29	0.018	0.03	229	2,510	1.2E-31	4.1E-29	
MW-202	Benzo(b)fluoranthene	32	82,683	0.012	3.4E-24	0.018	0.03	229	2,510	5.4E-27	1.9E-24	

Notes:

- 1: Density estimated to be equivalent to the 5-6 equivalent carbon aliphatic density listed in MTCA Table 747-4 (670 g/L).
- 2: Density estimated to be equivalent to the >12-16 equivalent carbon aliphatic density listed in MTCA Table 747-4 (770 g/L)
- 3: Density estimated to be equivalent to the >21-34 equivalent carbon aliphatic density listed in MTCA Table 747-4 (790 g/L)
- 4: Xylene isomers assumed to each have a concentration of one-third the total xylene concentration. Site RAL listed is for the sum of xylene isomers.

Surface water criteria from the National Recommended Water Criteria. http://water.epa.gov/scitech/swguidance/water_quality/standards/current/index.cfm. Last Accessed September 28, 2010.

COC = Constituent of concern

mL/g = milliliters per gram

ft/day = feet per day

ft = feet

day⁻¹ = per day

µg/L = micrograms per liter

g/L = grams per liter

m² = square meters

m³/day = cubic meter per day

lbs/day = pounds per day

lbs/yr = pounds per year

kg/L = kilograms per liter

mL/yr = cubic centimeters per year

MTCA = Model Toxics Control Act

SO₄ = sulfate

TPH-G = Total petroleum hydrocarbons - gasoline

TPH-D = Total petroleum hydrocarbons - diesel

TPH-O = Total petroleum hydrocarbons - oil

NE = Not established

Table 16
Summary of Current Groundwater Concentrations, RALs and Maximum Predicted
Groundwater COC Concentrations at the Sea Wall

Former Unocal Seattle Marketing Terminal
 3001 Elliott Avenue
 Seattle, Washington

Parameter	Maximum COC Concentrations in Groundwater From May 2009 to September 2010 (µg/L)	Site Groundwater RAL (µg/L)	Maximum Predicted Groundwater COC Concentration at Sea Wall (µg/L)	Notes
LNAPL	No visible sheen	No visible sheen	No visible sheen	
TPH-G	1,500	1,000	20	
TPH-D	1,500	10,000	7.2E-08	
TPH-O	840	15,000	1.4E-294	
Benzene	3.43	40	1.0	
Toluene	2.1	14,300	0.0061	
Ethylbenzene	1.12	1,400	1.6E-05	
Total Xylenes	7.7	4,400	2.4E-04	
Dissolved Lead	ND	50	NA	1,2
cPAHs				2
Benzo(a)anthracene	0.049/ND	0.03	2.2E-11	3
Benzo(a)pyrene	ND/ND	0.03	NA	3
Benzo(b)fluoranthene	0.012/ND	0.03	3.4E-24	3
Benzo(k)fluoranthene	ND/ND	0.03	NA	3
Chrysene	0.047/ND	0.03	8.5E-14	3
Dibenzo(a,h)anthracene	ND/ND	0.03	NA	3
Indeno(1,2,3-cd)pyrene	ND/ND	0.03	NA	3

Notes:

¹: Lead MCL not established for surface water consumption of organisms, for comparison purposes only, 4-hour continuous MCL for lead is 8.1 µg/L.

²: Lead and cPAHs are not COCs for the Elliott Avenue Area

³: cPAH concentration data presented in non-filtered/field filtered format.

Surface water criteria from the National Recommended Water Criteria. [http://water.epa.gov/scitech/swguidance/water quality/standards/current/index.cfm](http://water.epa.gov/scitech/swguidance/water_quality/standards/current/index.cfm). Last Accessed September 28, 2010.

RAL = Remedial action level

NE = Not established

NA = Not applicable

µg/L = micrograms per liter

mg/L = milligrams per liter

LNAPL = light non-aqueous phase liquid

TPH-G = Total petroleum hydrocarbons - gasoline

TPH-D = Total petroleum hydrocarbons - diesel

TPH-O = Total petroleum hydrocarbons - oil

cPAH = Carcinogenic polyaromatic hydrocarbons

COC = Constituent of concern

ARCADIS

Figures

CITY: SYRACUSE DIV/GROUP: 141 DB: IAR GWS LD(Opt) PIC: J. VOGELY PM: R. ANDRESEN TM: R. ANDRESEN LVR: ONE OFF-REF
 GAENVCAD1\tempa-BACT\B0045363 Seattle Market\003000082010 SR&R\B0045363B02.dwg LAYOUT: 3 SAVED: 17/2011 10:51 AM ACADVER: 18.00 (LMS TECH) PAGES: 17/2011 10:51 AM BY: RICHARDS, JIM
 XREFS: IMAGES: PROJECTNAME: --

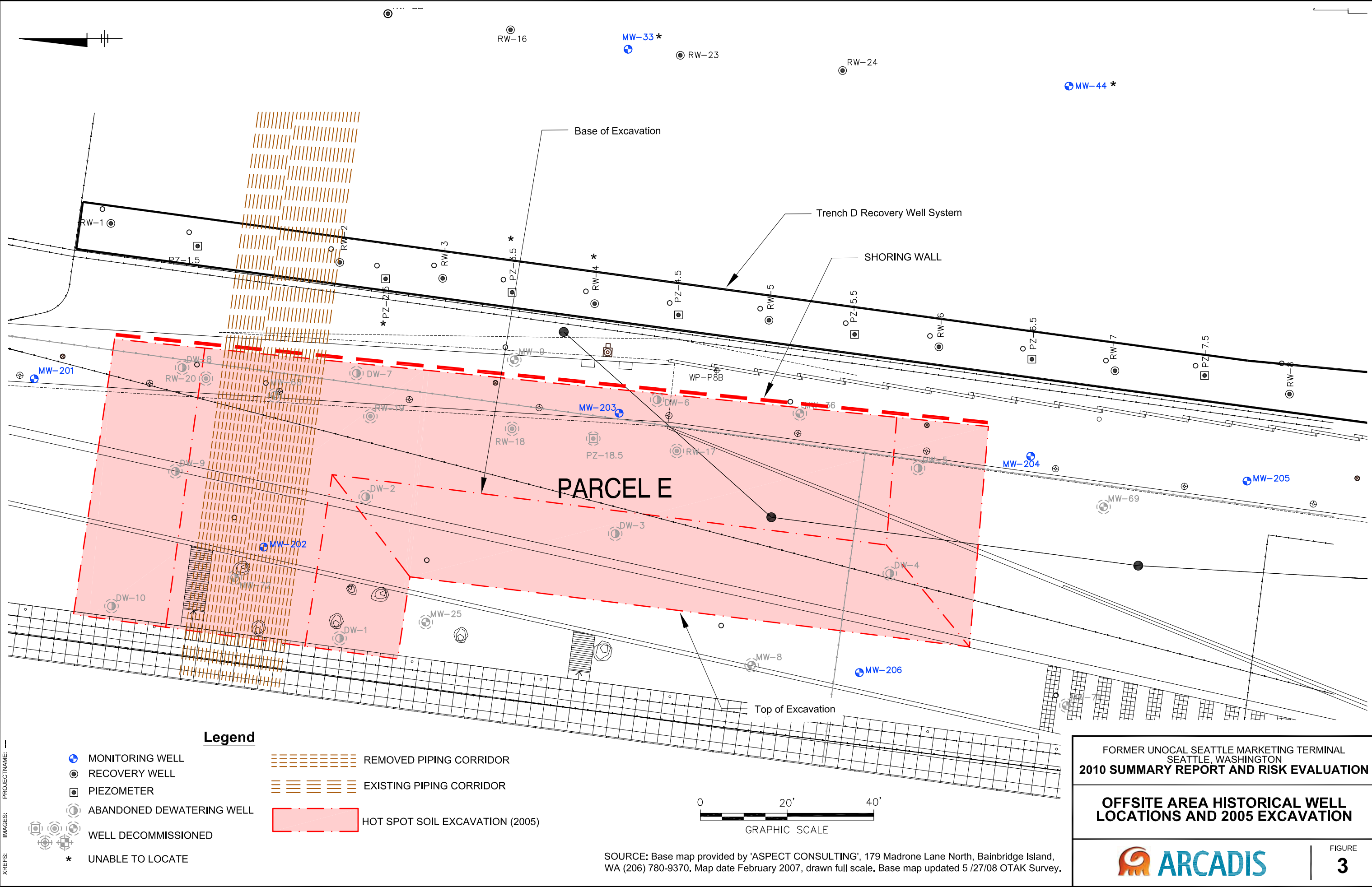

FORMER UNOCAL SEATTLE MARKETING TERMINAL
 SEATTLE, WASHINGTON
2010 SUMMARY REPORT AND RISK EVALUATION

**OFFSITE AREA HISTORICAL WELL
 LOCATIONS AND 2005 EXCAVATION**

ARCADIS

FIGURE
3

CITY: TAMPA-FL DIV: GROUP: PEN-141 DR: JAR LD: (Opt) PIC: J. VOGELY PM: R. ANDRESEN TM: R. ANDRESEN LTR: ONH-OFF-REF
 G:\ENVCAD\Tampa-BACT\B045363 Seattle Market\003000089\2010 SR&RE\B045363\03.dwg LAYOUT: 7. SAVED: 1/7/2011 10:40 AM. ACADVER: 18.00
 XREFS: IMAGES: PROJECTNAME: -

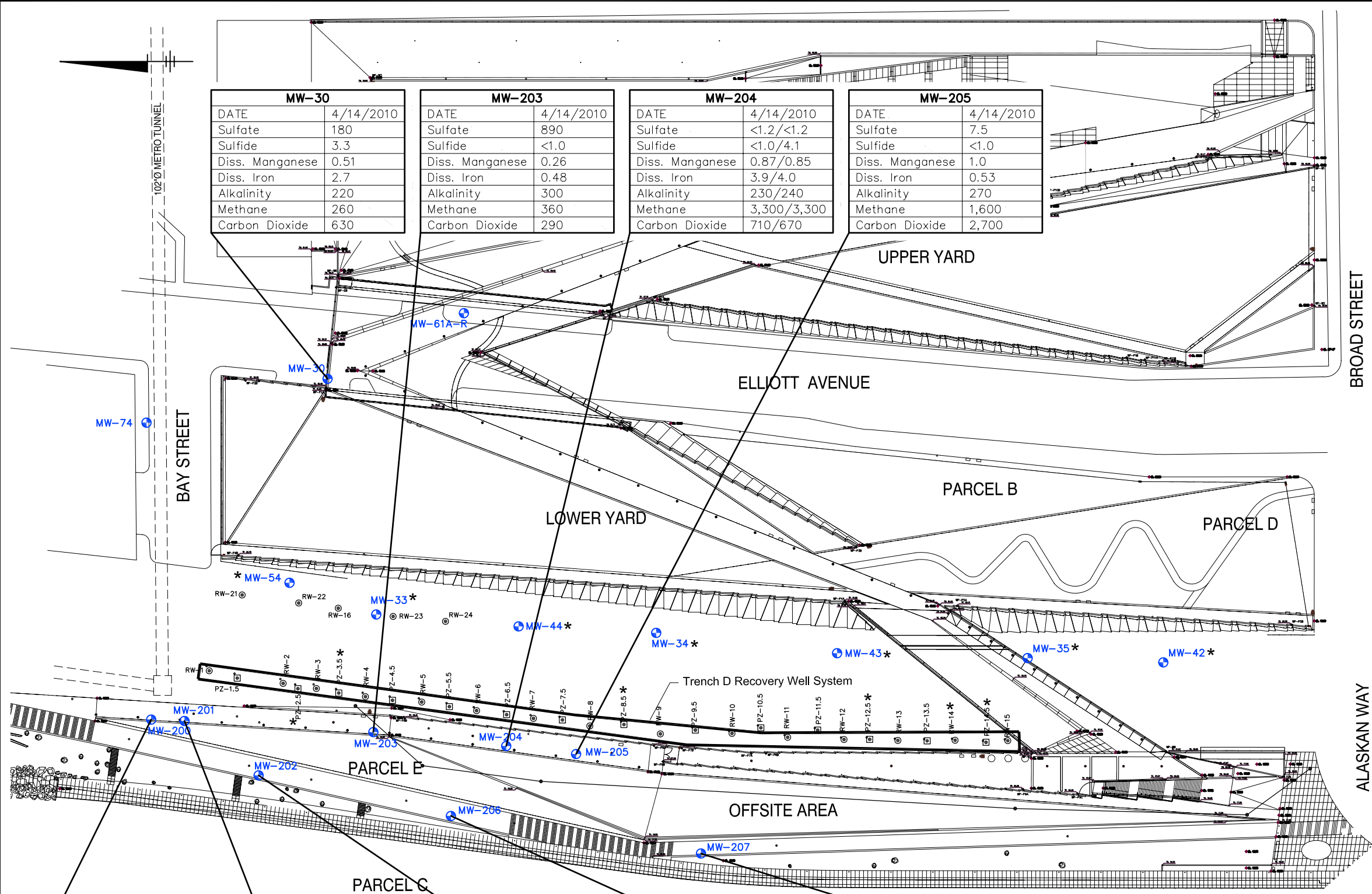

MW-30	
DATE	4/14/2010
Sulfate	180
Sulfide	3.3
Diss. Manganese	0.51
Diss. Iron	2.7
Alkalinity	220
Methane	260
Carbon Dioxide	630

MW-203	
DATE	4/14/2010
Sulfate	890
Sulfide	<1.0
Diss. Manganese	0.26
Diss. Iron	0.48
Alkalinity	300
Methane	360
Carbon Dioxide	290

MW-204	
DATE	4/14/2010
Sulfate	<1.2/<1.2
Sulfide	<1.0/4.1
Diss. Manganese	0.87/0.85
Diss. Iron	3.9/4.0
Alkalinity	230/240
Methane	3,300/3,300
Carbon Dioxide	710/670

MW-205	
DATE	4/14/2010
Sulfate	7.5
Sulfide	<1.0
Diss. Manganese	1.0
Diss. Iron	0.53
Alkalinity	270
Methane	1,600
Carbon Dioxide	2,700

MW-200	
DATE	4/14/2010
Sulfate	21
Sulfide	<1.0
Diss. Manganese	0.56
Diss. Iron	1.0
Alkalinity	320
Methane	4,100
Carbon Dioxide	340

MW-201	
DATE	4/14/2010
Sulfate	5.3
Sulfide	<1.0
Diss. Manganese	0.24
Diss. Iron	0.52
Alkalinity	280
Methane	5,100
Carbon Dioxide	610

MW-202	
DATE	4/14/2010
Sulfate	930
Sulfide	1.3
Diss. Manganese	0.12
Diss. Iron	<0.20
Alkalinity	310
Methane	850
Carbon Dioxide	350

MW-206	
DATE	4/13-14/2010
Sulfate	1,800
Sulfide	1.1
Diss. Manganese	0.34
Diss. Iron	0.53
Alkalinity	170
Methane	120
Carbon Dioxide	210

MW-207	
DATE	4/13-14/2010
Sulfate	1,400
Sulfide	<1.0
Diss. Manganese	0.041
Diss. Iron	<0.20
Alkalinity	230
Methane	780
Carbon Dioxide	740

Legend

- ⊕ MONITORING WELL
- ⊙ RECOVERY WELL
- ▣ PIEZOMETER
- * UNABLE TO LOCATE

NOTES:

RESULTS REPORTED IN MILLIGRAMS PER LITER (mg/L), EXCEPT FOR METHANE AND CARBON DIOXIDE RESULTS REPORTED IN MICROGRAMS PER LITER (µg/L)

<0.5/<0.5 = DUPLICATE SAMPLE

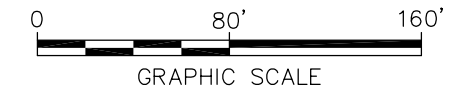

FORMER UNOCAL SEATTLE MARKETING TERMINAL
 SEATTLE, WASHINGTON
2010 SUMMARY REPORT AND RISK EVALUATION

**GEOCHEMICAL PARAMETER
 SUMMARY MAP - APRIL 2010**



SOURCE: Base map provided by 'ASPECT CONSULTING', 179 Madrone Lane North, Bainbridge Island, WA (206) 780-9370. Map date February 2007, drawn full scale. Base map updated 5/27/08 OTAK Survey.

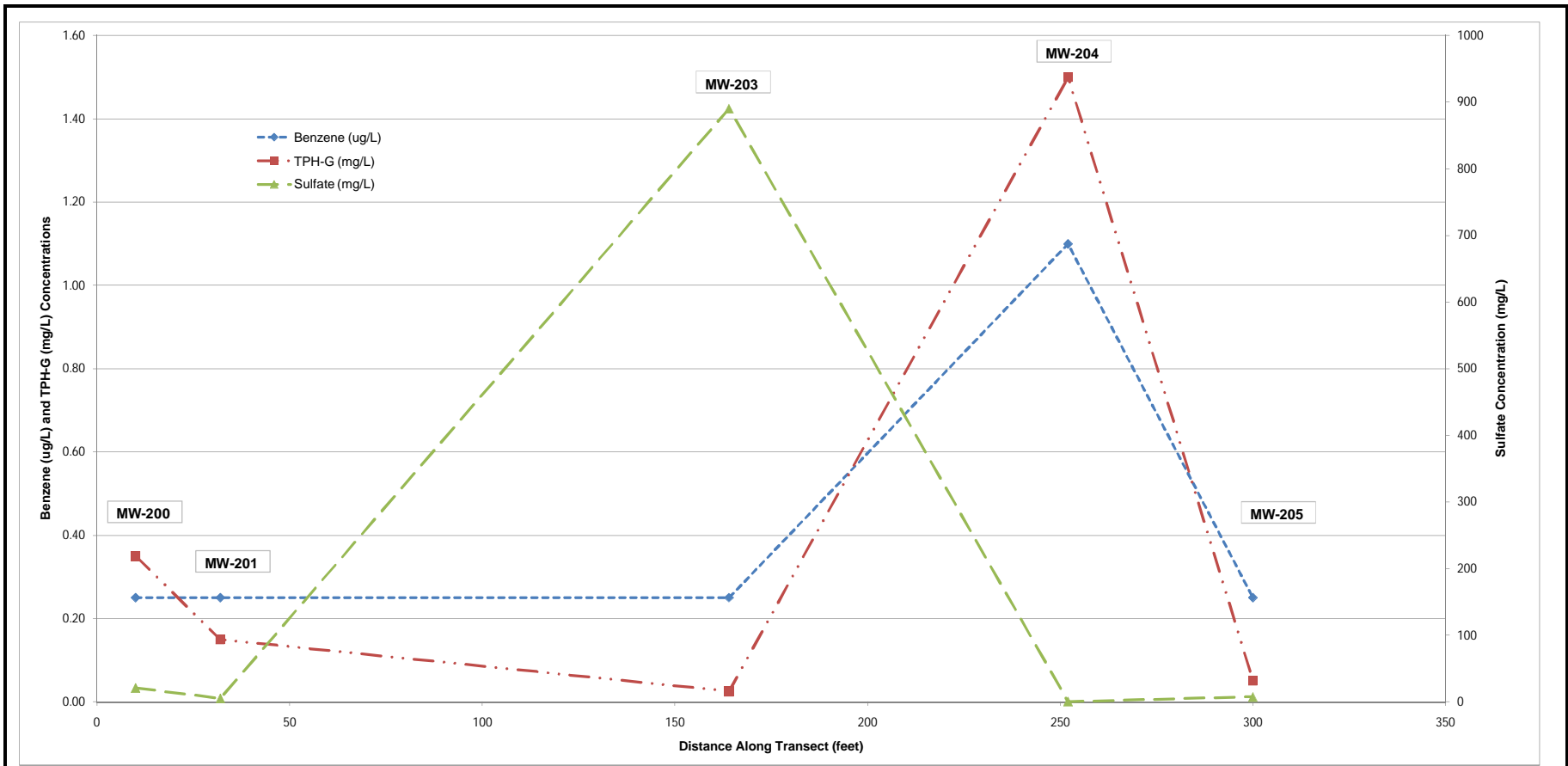

LEGEND:
 ug/L = micrograms per liter
 mg/L = milligrams per liter
 TPH-G = Total petroleum hydrocarbons - gasoline

Transect Shown on Figure 6.
 Only primary sample analytical data used for well MW-204, duplicate data not included.

Distances along transect:
 MW-200 - 10 feet
 MW-201 - 32 feet
 MW-203 - 164 feet
 MW-204 - 252 feet
 MW-205 - 300 feet

FORMER UNOCAL SEATTLE MARKETING TERMINAL
 3001 ELLIOTT AVENUE, SEATTLE, WASHINGTON
2010 SUMMARY REPORT AND RICK EVALUATION

**SULFATE AND COC CONCENTRATIONS ALONG
 TRANSECT**



**FIGURE
 8**

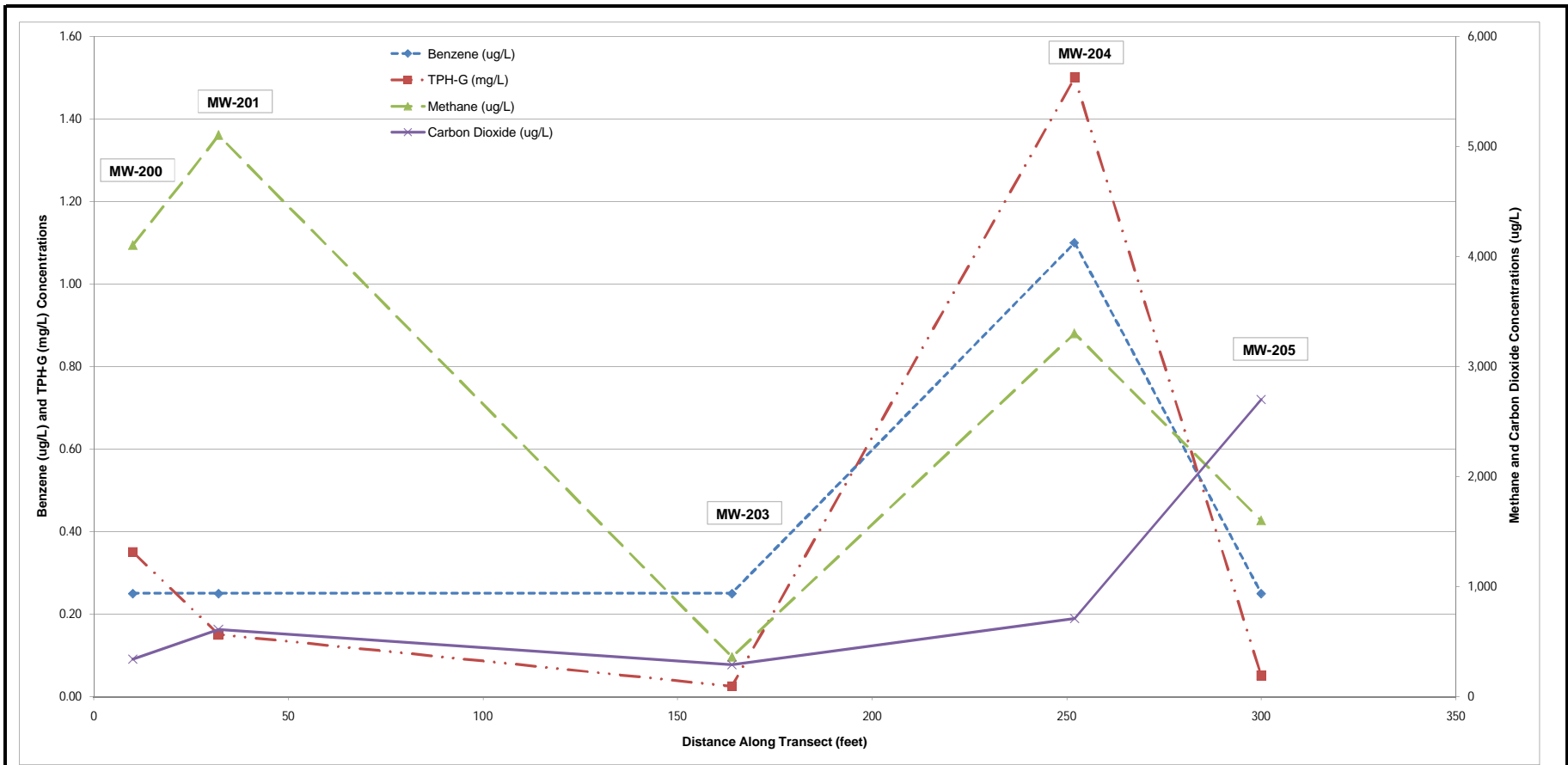

LEGEND:
 ug/L = micrograms per liter
 mg/L = milligrams per liter
 TPH-G = Total petroleum hydrocarbons - gasoline

Transect Shown on Figure 6.
 Only primary sample analytical data used for well MW-204, duplicate data not included.

Distances along transect:
 MW-200 - 10 feet
 MW-201 - 32 feet
 MW-203 - 164 feet
 MW-204 - 252 feet
 MW-205 - 300 feet

FORMER UNOCAL SEATTLE MARKETING TERMINAL
 3001 ELLIOTT AVENUE, SEATTLE, WASHINGTON
2010 SUMMARY REPORT AND RISK EVALUATION

**METHANE, CARBON DIOXIDE AND COC
 CONCENTRATIONS ALONG TRANSECT**



FIGURE

9

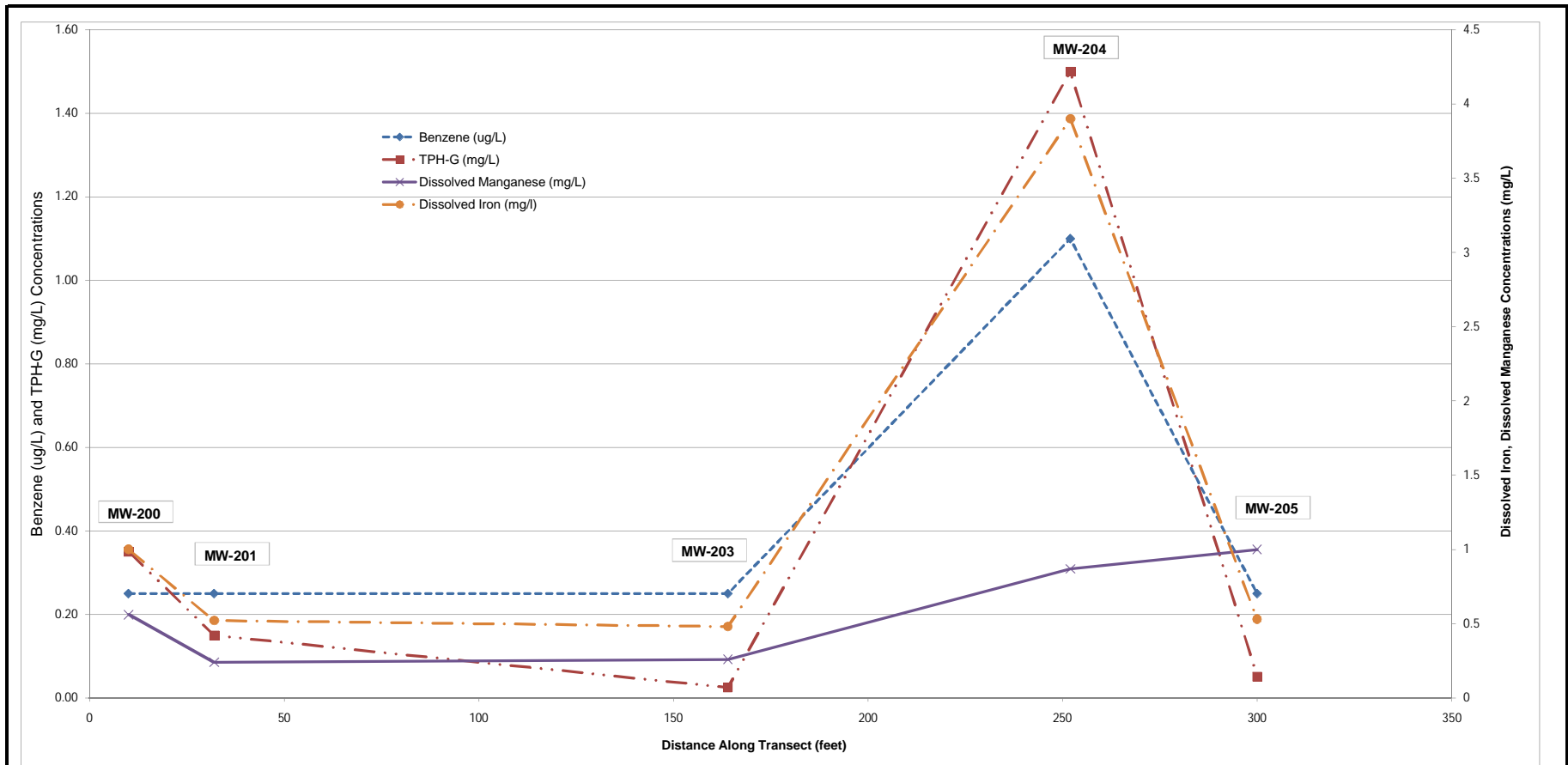

LEGEND:
 ug/L = micrograms per liter
 mg/L = milligrams per liter
 TPH-G = Total petroleum hydrocarbons - gasoline

Transect Shown on Figure 6.
 Only primary sample analytical data used for well MW-204, duplicate data not included.

Distances along transect:
 MW-200 - 10 feet
 MW-201 - 32 feet
 MW-203 - 164 feet
 MW-204 - 252 feet
 MW-205 - 300 feet

FORMER UNOCAL SEATTLE MARKETING TERMINAL
 3001 ELLIOTT AVENUE, SEATTLE, WASHINGTON
2010 SUMMARY REPORT AND RISK EVALUATION

**DISSOLVED IRON, DISSOLVED MANGANESE AND COC
 CONCENTRATIONS ALONG TRANSECT**



FIGURE
10

CITY: SYRACUSE DIMGROUP: 141 DB: IAR GMS LD(OH) PIC: J. VOGELY PW: R. ANDRESEN TM: R. ANDRESEN LVR: ONE OFF-REF
 G:\ENVCAD\Tampa-BACT\B045363 Seattle Market\003000082010 SR&R\B045363B04.dwg LAYOUT: 11 _SAVED: 1/7/2011 10:48 AM ACADVER: 18.05 (LMS TECH) PAGES: 18.05 (LMS TECH) PLOTSTYLETABLE: PLTFULL.CTB PLOTTED: 1/7/2011 10:49 AM BY: RICHARDS, JIM

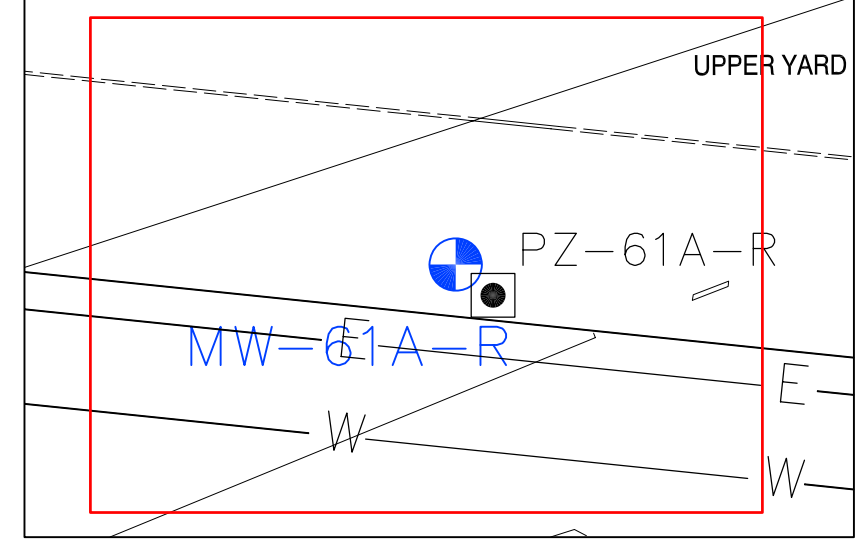
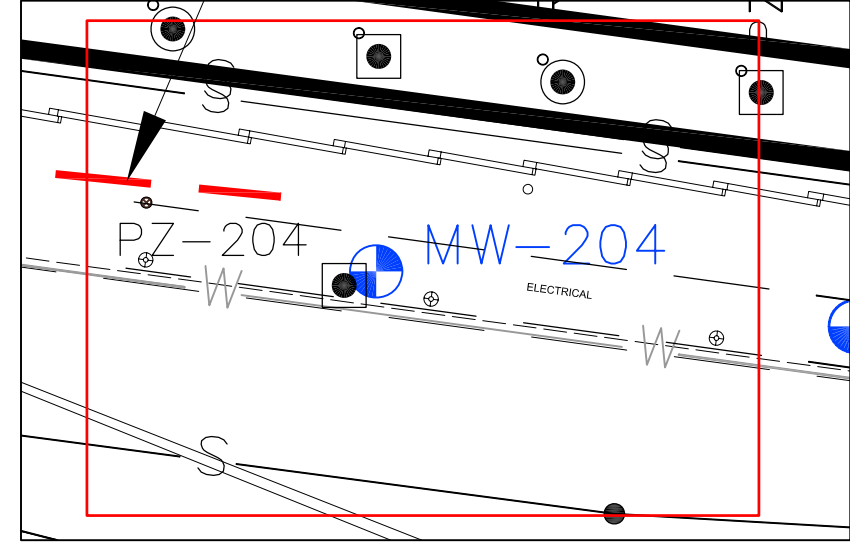
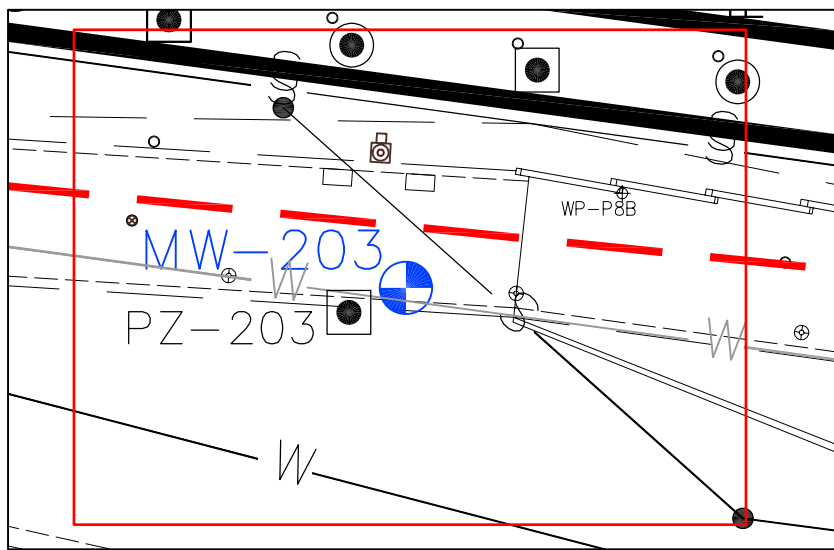
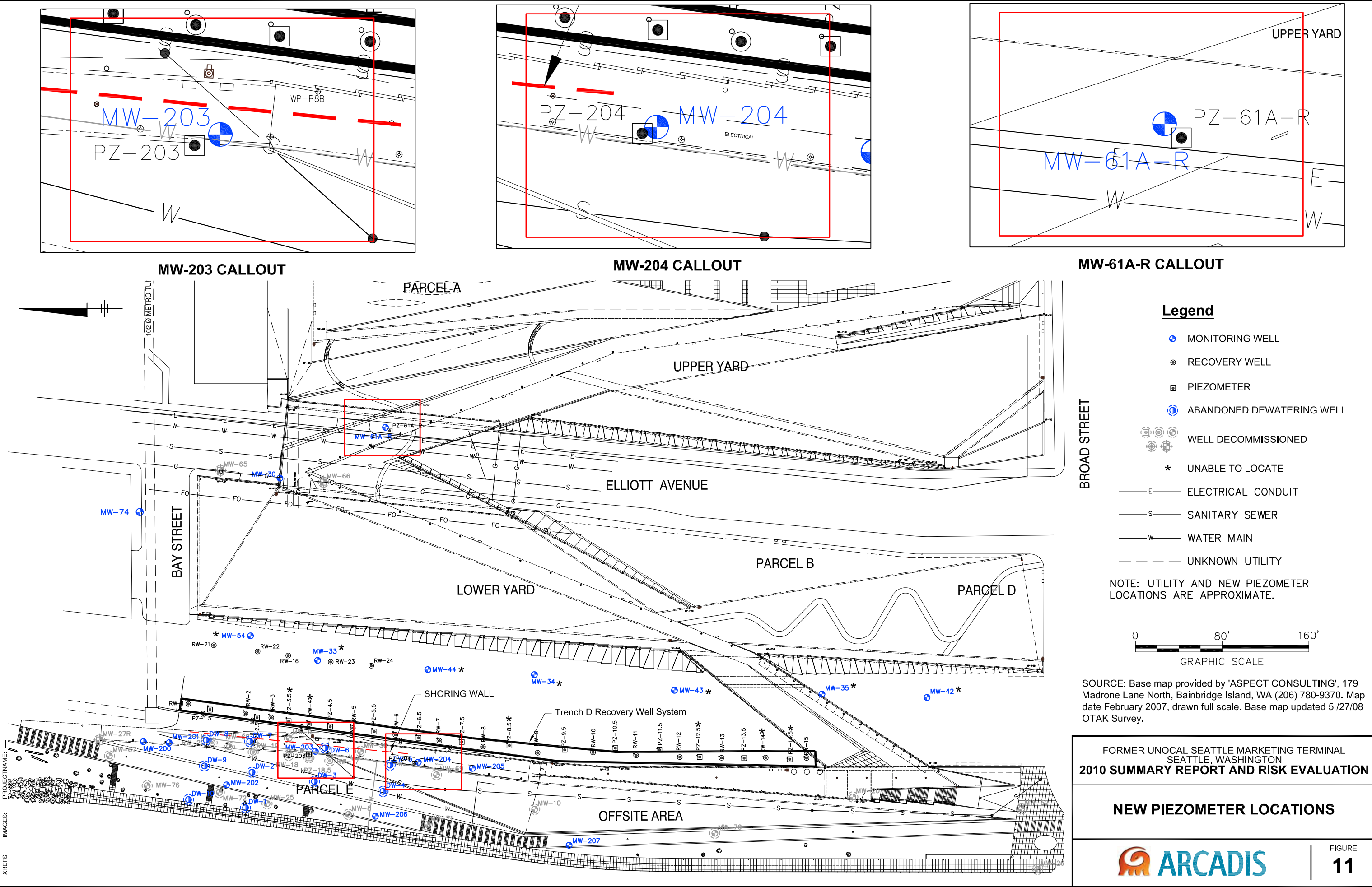

- Legend**
- MONITORING WELL
 - RECOVERY WELL
 - PIEZOMETER
 - ABANDONED DEWATERING WELL
 - WELL DECOMMISSIONED
 - UNABLE TO LOCATE
 - ELECTRICAL CONDUIT
 - SANITARY SEWER
 - WATER MAIN
 - UNKNOWN UTILITY

NOTE: UTILITY AND NEW PIEZOMETER LOCATIONS ARE APPROXIMATE.

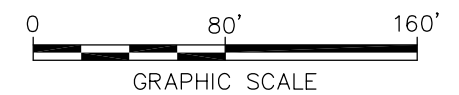

SOURCE: Base map provided by 'ASPECT CONSULTING', 179 Madrone Lane North, Bainbridge Island, WA (206) 780-9370. Map date February 2007, drawn full scale. Base map updated 5/27/08 OTAK Survey.

FORMER UNOCAL SEATTLE MARKETING TERMINAL
 SEATTLE, WASHINGTON
2010 SUMMARY REPORT AND RISK EVALUATION

NEW PIEZOMETER LOCATIONS



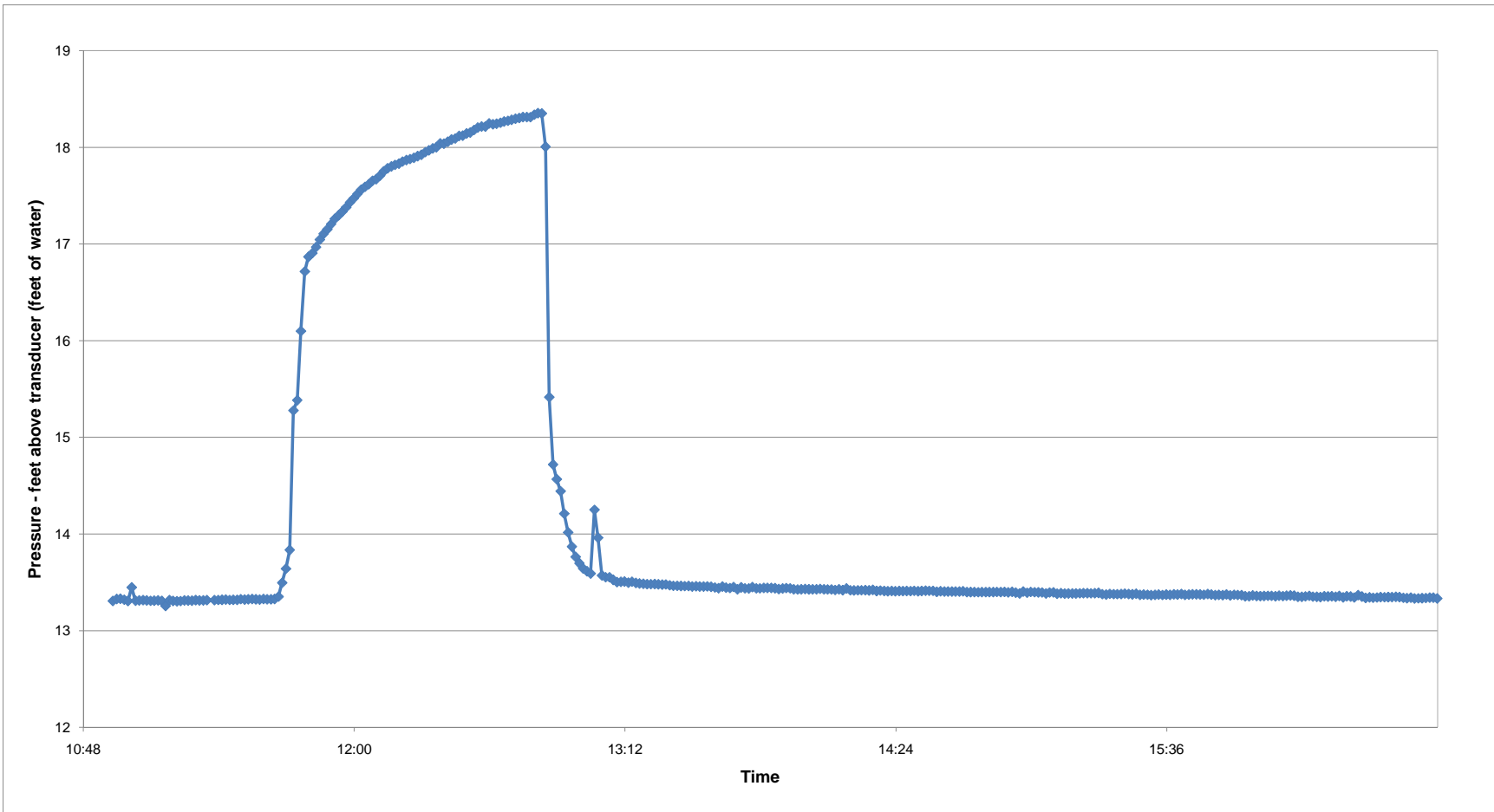

NOTES:

FORMER UNOCAL SEATTLE MARKETING TERMINAL
 3001 ELLIOTT AVENUE, SEATTLE, WASHINGTON
2010 SUMMARY REPORT AND RISK EVALUATION

**MOUNDING IN WELL MW-61A-R DURING SURFACTANT
 INJECTION OPERATIONS**



FIGURE
12

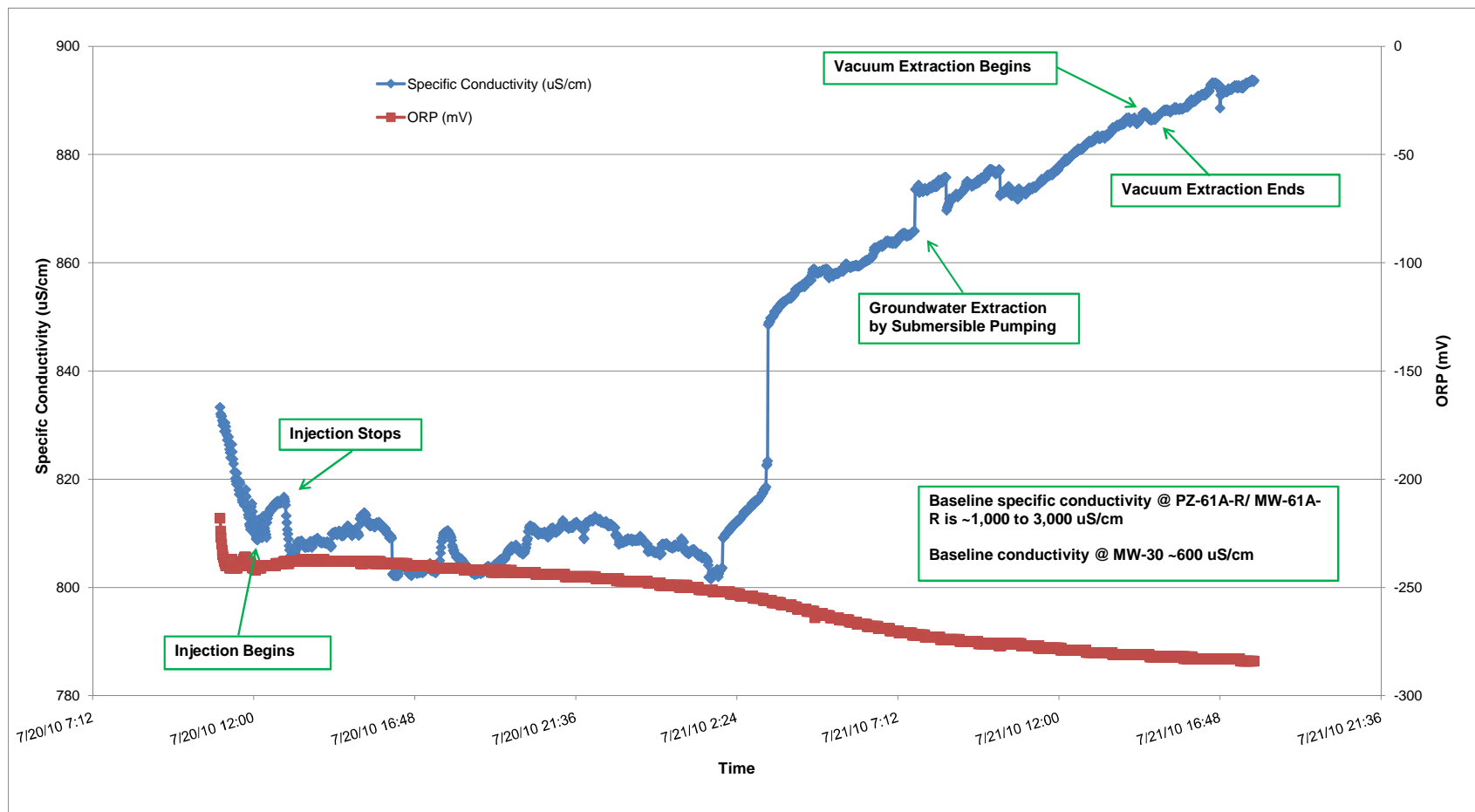

LEGEND:

uS/cm = microSiemens per centimeter
 ORP = oxidation-reduction potential
 mV = millivolts

FORMER UNOCAL SEATTLE MARKETING TERMINAL
 3001 ELLIOTT AVENUE, SEATTLE, WASHINGTON
2010 SUMMARY REPORT AND RISK EVALUATION

**SURFACTANT INJECTION MONITORING IN
 WELL MW-30**



**FIGURE
 13**

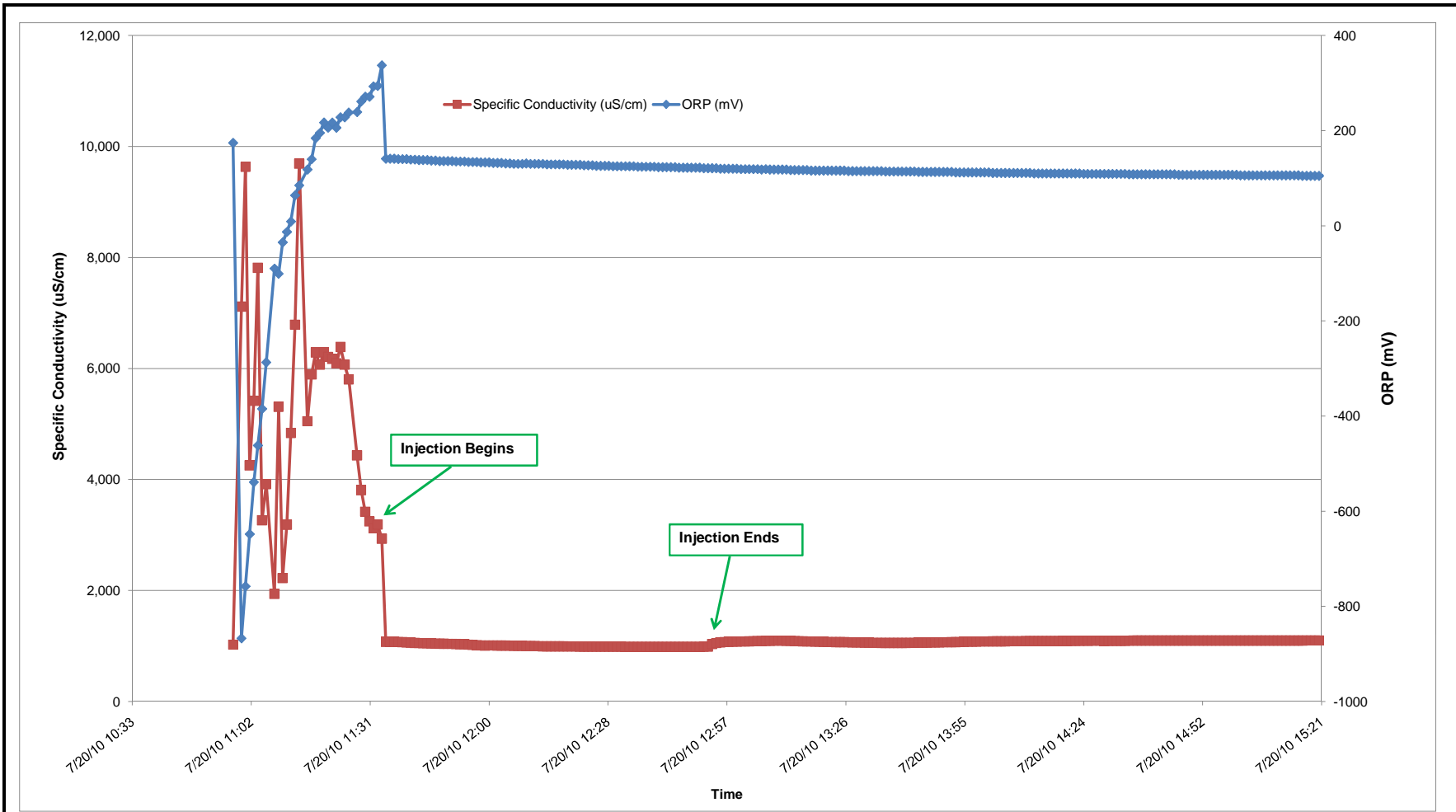

LEGEND:
 uS/cm = microSiemens per centimeter
 ORP = oxidation-reduction potential
 mV = millivolts

FORMER UNOCAL SEATTLE MARKETING TERMINAL
 3001 ELLIOTT AVENUE, SEATTLE, WASHINGTON
2010 SUMMARY REPORT AND RISK EVALUATION

**SURFACTANT INJECTION MONITORING IN
 PIEZOMETER PZ-61A-R**



**FIGURE
 14**

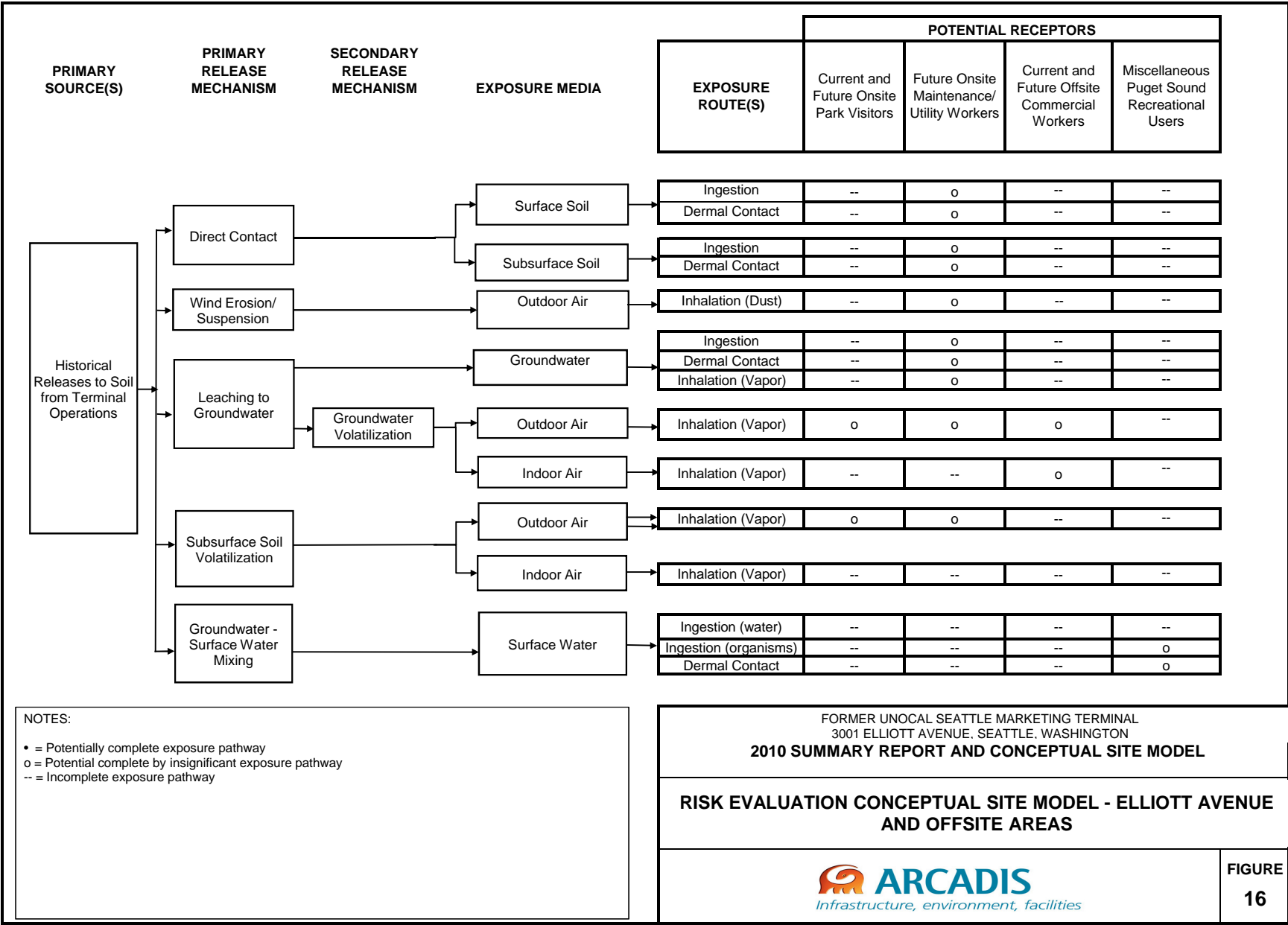

NOTES:

- = Potentially complete exposure pathway
- o = Potential complete by insignificant exposure pathway
- = Incomplete exposure pathway

FORMER UNOCAL SEATTLE MARKETING TERMINAL
 3001 ELLIOTT AVENUE, SEATTLE, WASHINGTON
2010 SUMMARY REPORT AND CONCEPTUAL SITE MODEL

RISK EVALUATION CONCEPTUAL SITE MODEL - ELLIOTT AVENUE AND OFFSITE AREAS



FIGURE
16