

INTERIM ACTION WORK PLAN CENTRAL WATERFRONT SITE, ALL AMERICAN MARINE BUILDING AND C STREET TERMINAL

Prepared for:

Port of Bellingham

Prepared by:

Anchor QEA, LLC

720 Olive Way, Suite 1900

Seattle, Washington 98201

March 2016

TABLE OF CONTENTS

1	INTRODUCTION	1
1.1	Site Description and Background.....	1
1.2	Work Plan Organization.....	2
2	OVERVIEW OF INTERIM ACTIONS TO BE PERFORMED.....	3
2.1	C Street Terminal Interim Action Area.....	3
2.1.1	Sources of Contamination.....	3
2.1.2	Contaminants of Concern.....	3
2.1.3	Goals of Interim Action.....	4
2.1.4	Project Implementation.....	4
2.2	All American Marine Interim Action Area.....	5
2.2.1	Sources of Contamination.....	5
2.2.2	Contaminants of Concern.....	5
2.2.3	Goals of Interim Action.....	5
2.2.4	Project Implementation.....	6
2.3	Soil Cleanup Levels.....	6
3	INTERIM ACTION COMPONENTS.....	7
3.1	Soil Management.....	7
3.2	Cap Construction.....	8
3.3	Landfill Gas Control System.....	9
3.4	Compliance Monitoring.....	10
3.4.1	Protection Monitoring.....	10
3.4.2	Performance Monitoring.....	11
4	PERMITTING AND SUBSTANTIVE REQUIREMENTS.....	12
5	REPORTING.....	13
6	SCHEDULE.....	14
7	INTEGRATION WITH FINAL CLEANUP ACTION.....	15
8	REFERENCES.....	16

List of Tables

Table 1 Soil Cleanup Levels
Table 2 Permits and Substantive Requirements

List of Figures

Figure 1 Vicinity Map
Figure 2 Central Waterfront Site Subareas
Figure 3 Location of Interim Action Projects
Figure 4 Detailed Remedial Components of C Street Terminal Project
Figure 5 Detailed Remedial Components of All American Marine Project

Attachment A

Landfill Gas Control System Design (Landau Associates 2016)

LIST OF ACRONYMS AND ABBREVIATIONS

AAM	All American Marine
AO	Agreed Order
cfm	cubic feet per minute
City	City of Bellingham
COC	contaminants of concern
Ecology	Washington State Department of Ecology
GP	Georgia-Pacific
IA	interim action
LFG	landfill gas
O&M	Operation and Maintenance
PAHs	polycyclic aromatic hydrocarbons
Port	Port of Bellingham
RI/FS	remedial investigation/feasibility study
Site	Central Waterfront Site
TPH-D	total petroleum hydrocarbons-diesel range
TPH-G	total petroleum hydrocarbons-gasoline range
TPH-MO	total petroleum hydrocarbons-motor oil range
UST	underground storage tank
WAC	Washington Administrative Code
Work Plan	Interim Action Work Plan

1 INTRODUCTION

The Port of Bellingham (Port) intends to construct a new building and other site improvements in support of marine trades within portions of the Central Waterfront Site (Site) in Bellingham, Washington (Figure 1): All American Marine (AAM) and C Street Terminal projects. Portions of this work have been identified as interim actions (IA) by the Washington State Department of Ecology (Ecology). The IA work to be performed includes removal and disposal and/or capping of contaminated soils, and installation of a landfill gas (LFG) collection system.

The IAs will be conducted under Agreed Order (AO) No. DE 3441 as amended (Ecology 2006, 2012a) between the Port, the City of Bellingham (City), and Ecology. This Interim Action Work Plan (Work Plan) has been prepared in accordance with the AO and, once approved by Ecology, will become an integral and enforceable part of the AO.

The remedial action work described in this work plan will be implemented in coordination with planned redevelopment activities associated with the AAM and C Street Terminal projects.

1.1 Site Description and Background

The Site, located in Bellingham, Washington, encompasses 55 acres and includes both upland property (bounded by the Whatcom and I & J Waterways, Roeder Avenue, and the former Aerated Stabilization Basin facility) and in-water nearshore surface sediments in Whatcom Waterway. The Site is comprised of four contaminated sites that were formerly managed separately under the Model Toxics Control Act: the Roeder Avenue Landfill site, the Olivine Corporation Hilton site (Olivine Uplands), the Chevron Bellingham Port site (Chevron Terminal), and the Colony Wharf site. In 2003, due to the presence of comingled groundwater contamination, Ecology consolidated these four sites into a single area-wide site now known as the Central Waterfront Site. In 2006, the Port and City entered into the AO with Ecology to perform a remedial investigation/feasibility study (RI/FS) for the Site, which is currently in progress.

The first amendment to the AO (AO Amendment 2012) allows the Port and City to undertake IAs before completing the RI/FS, with public review and Ecology approval, in accordance with Washington Administrative Code (WAC) 173-340-430 and WAC 173-340-600(16). The IAs outlined in this Work Plan will reduce the potential threat to human health or the environment by eliminating or substantially reducing one or more pathways for exposure to a hazardous substance at the Site. The IAs will be implemented in advance of selecting the final cleanup action for the Site and will not preclude reasonable alternatives for the final cleanup action (WAC 173-340-430(3)(b)).

The Site is divided into three subareas based on historical land use and associated contamination: the Landfill and Perimeter subarea, C Street Properties subarea, and Hilton Avenue Properties subarea (Figure 2). The AAM IA area is located within the Landfill and Perimeter and the Hilton Avenue Properties subareas. The C Street Terminal IA area is located within the C Street Properties subarea.

1.2 Work Plan Organization

Following this introductory section, the remaining sections of this Work Plan are as follows:

- Section 2 – Overview of Interim Actions to be Performed
- Section 3 – Interim Action Components
- Section 4 – Permitting and Substantive Requirements
- Section 5 – Reporting
- Section 6 – Schedule
- Section 7 – Integration with Final Cleanup Action
- Section 8 – References

2 OVERVIEW OF INTERIM ACTIONS TO BE PERFORMED

This section describes the sources of contamination, contaminants of concern (COCs), goals, and project implementation for each IA area.

2.1 C Street Terminal Interim Action Area

2.1.1 Sources of Contamination

Sources of contamination in the C Street Terminal IA area include the former Chevron Terminal and Colony Wharf. The former Chevron Terminal operated as a bulk fuel terminal from approximately 1913 until the late 1980s. The former terminal included two tank farms, a marine vessel loading dock with associated piping, three tanker truck loading racks, a rail loading rack, product storage warehouse and office, and facility piping and stormwater management features.

The former Colony Wharf properties have been used for a variety of industrial activities. Historical land uses include sales of building products (coal, lime, cement, plaster, brick, and tile); steel casting company; foundry operations; truck garage; manufacture of cement products; boat repair and maintenance; machine shop and welding; fish and seafood distribution; and electrical equipment manufacture, sales, and repair. In addition, two underground storage tanks (USTs) and an associated fuel dispenser were used at the property for gasoline storage and fueling.

2.1.2 Contaminants of Concern

Petroleum hydrocarbons and associated constituents (total petroleum hydrocarbons-gasoline range [TPH-G], TPH-diesel range [TPH-D], TPH-motor oil range [TPH-MO], and benzene, polycyclic aromatic hydrocarbons [PAHs]) have been identified as the COCs in soil, sediment, and groundwater within the former Chevron Terminal area. Some metals-impacted soils and shoreline sediments identified at the former Colony Wharf area have been associated with historical foundry and boatyard operations. In addition, petroleum-impacted groundwater has been identified and is associated with former UST releases. The petroleum-impacted groundwater is comingled with contamination from the former Chevron Terminal area.

2.1.3 Goals of Interim Action

Soil impacts have been identified in the area of the C Street Terminal project and represent an ongoing source of contamination to Site groundwater, surface water, and sediment, and pose potential risk to Site workers and the public via direct contact and indoor air inhalation. Site-wide remedial alternatives are currently being evaluated in the RI/FS. However, due to the Port's development schedule, soil impacts in the immediate area of the C Street Terminal project will be addressed as an interim cleanup action. Based on the available investigation information, the goal of the C Street Terminal IA presented in this Work Plan is to achieve permanent control of localized soil sources to groundwater, surface water, and sediment, and prevent exposure to Site workers and the public through isolation and removal of contaminated soil for off-Site disposal. Specific goals for this IA are to:

- Reduce mass of contaminants in soil through subsurface excavations for construction of utilities
- Prevent potential exposure via direct contact to contaminated soils located in the footprint of the project by capping

2.1.4 Project Implementation

The C Street Terminal project is a development plan proposed by the Port to rehabilitate upland infrastructure and enhance stormwater collection and treatment of the existing C Street waterfront terminal and adjacent right-of-way areas located at C Street and Maple Street. The project will address stormwater quality treatment according to the *Stormwater Management Manual for Western Washington* (Ecology 2012b). In addition, the project will enhance existing upland infrastructure to improve conditions for marine trades in the Whatcom Waterway area, including re-surfacing of roads to accommodate low ground clearance vehicles, converting portions of existing overhead power lines to underground, upgrading electrical service including new marine electrical service along the bulkhead, lighting, and water supply, and resurfacing C Street and the terminal for heavy vehicle use and site-specific stormwater collection.

The C Street Terminal IA integrates cleanup actions including isolation and containment of subsurface contaminants and excavation and off-site disposal of impacted soil removed for utility installation with the development project.

2.2 All American Marine Interim Action Area

2.2.1 Sources of Contamination

Sources of contamination in the All American Marine IA area include the former Roeder Avenue Landfill and perimeter areas, and various industrial activities performed in the Hilton Properties subarea. The Roeder Avenue Landfill was operated as a disposal site for wood waste and other material from the Georgia-Pacific (GP) mill and as the main disposal site for municipal refuse by the City between 1965 and 1974. Historical operations in the Hilton Avenue Properties subarea, along the northern shoreline of the Site, included lumber mill operations, trucking, production of foundry sand and olivine-based refractory materials for incinerators, olivine processing, and bulk fuel terminal operations.

2.2.2 Contaminants of Concern

Landfill refuse and associated metals, petroleum hydrocarbons (TPH-G, TPH-D, and TPH MO), PAHs, volatile organic compounds, benzene, and semi-volatile compounds in groundwater and LFG are the COCs for the Landfill and Perimeter subarea. COCs in the Hilton Avenue Properties subarea include soil impacted by metals (primarily nickel) and PAHs from the creosote-treated timber pile bulkhead, former lumber mill, olivine processing facility and petroleum hydrocarbons (TPH-G, PAHs) in soil from the former Time Oil fuel terminal.

2.2.3 Goals of Interim Action

Soil impacts have been identified in the area of the AAM project and pose potential risk to Site workers and the public via direct contact and indoor air inhalation. Site-wide remedial alternatives are currently being evaluated in the RI/FS. However, due to the Port's development schedule, soil impacts in the immediate area of the AAM project will be addressed as an interim cleanup action. Based on the available investigation information, the goal of the AAM IA presented in this Work Plan is to achieve permanent control of localized soil sources to groundwater, surface water, and sediment, and prevent exposure to Site

workers and the public through isolation and removal of contaminated soil for off-Site disposal and landfill gas control. Specific goals for this IA are to:

- Reduce mass of contaminants in soil through subsurface excavations for construction of utilities and footings
- Prevent potential exposure via direct contact to contaminated soils located in the footprint of the project by capping
- Prevent potential indoor air exposure by installing an LFG collection system in conjunction with the construction of the AAM building

2.2.4 Project Implementation

The AAM project is located north of the Landfill Footprint subarea and south of Hilton Avenue. The Port and AAM plan to construct a new 60,000-square-foot marine manufacturing building and associated launch route from the building to the Squalicum Harbor boat launch.

The AAM IA integrates cleanup actions including isolation and containment of subsurface contaminants, excavation and off-site disposal of impacted soil removed for utility/foundation installation, and the installation of a LFG collection system with the development project.

2.3 Soil Cleanup Levels

The Site is currently within the RI/FS process; therefore, Ecology has not yet established final cleanup levels for the Site. However, the IA areas are defined based on soils located within the project footprints and extent of excavation required for construction purposes.

The anticipated soil cleanup levels for the Site based on a compilation of “most stringent screening levels” are provided in Table 1 and will be used for soil management purposes as described in Section 3.

3 INTERIM ACTION COMPONENTS

The IAs include excavation and off-Site disposal of contaminated soils, capping of soils, and installation of an LFG control system. General location of the IA projects is shown in Figure 3. Detailed remedial components for each of the IAs are shown in Figure 4 (C Street Terminal) and Figure 5 (AAM).

3.1 Soil Management

Installation of utilities and foundations associated with both the AAM and C Street Terminal projects will require excavation of contaminated soil. The IAs involve conventional excavation of contaminated soils, likely with ancillary uncontaminated soils, to depths necessary to allow construction of the projects.

Excavation will be performed within the AAM building footprint to construct grade beams varying between 30 and 48 inches in width, and 30 to 72 inches in depth. Trenches will also be excavated throughout the building footprint for electrical lines, plumbing drain lines, and methane vent lines (described in Section 3.3). Trenches will be 2 to 3 feet deep and the plumbing drain lines will be deeper to account for the slopes required to tie into the sewer system. On average, it is assumed that the subgrade will be 20 inches below the finished grade surfaces, including the finished slab of the building and the finished grade surface around the building. This results in an estimated quantity of soil excavation of 6,800 in-place cubic yards (cy) of soil.

An estimated total of 8,000 cy of impacted soils will be excavated from the footprint of the C Street Terminal. Approximately 4,000 cy of excavation will be required along C Street and at the terminal for asphalt/concrete paving. In addition, 5,500 feet of trenching will be required to install underground utilities and stormwater conveyance piping, producing approximately 3,000 cubic yards of excavated material. There will be up to 10 stormwater vaults installed to a maximum depth of about 10 feet. Excavations for vault installation will generate another 1,000 cy of material.

Excavation means and methods (sidewall slopes, excavation equipment) will be specified based on project construction requirements.

Excavated materials will either be stockpiled on-Site for subsequent testing and off-Site disposal as appropriate, or loaded directly into dump trucks for disposal in an approved off-Site disposal facility. Stockpiled soils will be sampled at a frequency of one sample per 200 cy and analyzed according to the COCs identified for the subarea within which they are generated. Analytical results will be compared to the soil cleanup levels presented in Table 1, and if soil concentrations are at or below the cleanup levels, soils may be designated for re-use on-Site or as part of construction. If soil concentrations exceed the cleanup levels, soils will be profiled and transported to an approved off-Site facility.

In accordance with Washington State Dangerous Waste regulations (WAC 173-303) and landfill requirements, waste profiling for excavation spoils will rely on data from samples representative of the materials to be disposed of. Based on the extensive Site characterization work completed to date, it is expected that soils will meet the requirements for disposal at a Subtitle D facility.

The Port will encourage direct loading of excavated materials into trucks for off-Site disposal to minimize stockpiling. In the event that temporary stockpiling of excavated soil is required, the stockpiled soil will be placed in bermed (e.g., concrete block), lined stockpile areas. The liner will consist of 15- to 20-mil geotextile and the stockpiles will be covered with Visqueen when not in use. Drainage water from the stockpiles will be managed in accordance with project-specific construction stormwater permits.

3.2 Cap Construction

Two types of caps will be constructed as part of the IAs: hardscape and landscape. Hardscape includes buildings, asphalt, and concrete and will consist of a minimum of 3 inches hardscape material underlain by a 4-inch minimum gravel base. Landscape caps will consist of a minimum 24 inches of uncontaminated material (topsoil/clean soil) with a marker fabric to define the base of the cap. Gravel surfacing and the launch route for the AAM project is still under design and may be considered an environmental cap in coordination with Ecology at a later date.

In addition, an Operation and Maintenance (O&M) Plan will be prepared for the caps (subsequent to this Work Plan) with the objective of ensuring long-term integrity of the containment systems, through routine inspection and maintenance.

3.3 Landfill Gas Control System

Current Site conditions within the footprint of the AAM building allow LFG in the soil to ventilate slowly to the atmosphere. After constructing the building slab, the surface will be relatively impermeable and buildup of LFG could occur. A first-order decay rate model was used to estimate the gas generation potential at the Landfill. The model estimated that most of the LFG produced by the Landfill was likely released to the atmosphere long ago, and that peak generation, which likely occurred in the 1970s, was less than 200 cubic feet per minute (cfm). The model estimates that LFG production has declined exponentially since that time to the current generation rate of about 25 cfm. Although this rate of production is relatively low, if the LFG is not provided with a ventilation route to the atmosphere, it could accumulate to unsafe or unhealthy concentrations. Although much of the building footprint is outside of the landfill waste boundary, considerations including proximity to the Landfill and the lack of LFG source controls are the basis for designing a mitigation system that will provide ongoing ventilation and protection for 1.4 cfm of LFG.

Construction of the building foundation will include a system of grade beams below the building floor slab. This type of building foundation could trap rising LFG in the rectangular “cells” created by the grade beams and perimeter footings. As a result, LFG controls are needed to provide a ventilation pathway for each of the isolated “cells” created by the foundation system. The LFG control system will generally consist of four components:

1. LFG collection layer (to capture rising LFG and convey it to the strip geocomposite)
2. Strip geocomposite (to convey LFG to vents that discharge above the roofline)
3. Vapor barrier (impermeable liner below the building slab to prevent vapor intrusion)
4. LFG vents (a series of vents that connect the strip geocomposite to the atmosphere)

Typical LFG collection layers include double-sided geonet/geotextile composites or gravel layers. The design of gas ventilation layers for LFG collection is based on the transmissivity

required to provide sufficient flow capacity to ventilate a given surface flux of gas based on the maximum allowable buildup of pressure within the system, and the spacing of pipes or strip geocomposites that connect to atmospheric conditions through direct vents (Landau Associates 2016; see Attachment A).

In addition, a monitoring plan for indoor air and vent pipe monitoring stations will be prepared (subsequent to this Work Plan) with the objective of monitoring the accumulation of landfill gas under the AAM building.

3.4 Compliance Monitoring

In accordance with WAC 173-340-410, compliance monitoring for a cleanup action includes the following elements:

- **Protection monitoring** confirms that human health and the environment are adequately protected during the cleanup action.
- **Performance monitoring** confirms that the cleanup action has attained cleanup levels and met other performance standards, such as permit requirements.
- **Confirmation monitoring** confirms the long-term effectiveness of the cleanup action once cleanup levels and other performance standards have been reached.

For these IAs, protection monitoring will be conducted during implementation of the IAs; the protection monitoring program for the IAs is outlined in Section 3.4.1. Performance monitoring will consist of construction monitoring and inspections, as described in Section 3.4.2. Confirmation monitoring will be conducted as part of the final Site cleanup action.

3.4.1 Protection Monitoring

Protection monitoring will be conducted during the IAs by requiring that on-Site construction workers performing soil excavation work and in contact with contaminated soils are appropriately trained in hazardous waste operations and follow the site-specific health and safety plan to be prepared specifically for the IA projects.

3.4.2 Performance Monitoring

Performance monitoring will consist of construction monitoring and inspection to ensure caps and the landfill gas collection system are constructed in accordance with design specifications. Review copies of project specifications will be provided to Ecology. An IA completion report will be prepared to document completion of construction of the IAs to meet the objectives stated herein.

4 PERMITTING AND SUBSTANTIVE REQUIREMENTS

These IAs will be conducted under AO No. DE 3441, as amended, with Ecology. The amended AO requires identification of the permits or specific federal, state, or local requirements that Ecology has determined are applicable and that are known at the time of entry of the AO. When performing the IAs, the Port and the City are exempt from the procedural requirements of Chapters 70.94, 70.95, 70.105, 77.55, 90.48, and 90.58 Revised Code of Washington and of any laws requiring or authorizing local government permits or approvals, but must still comply with the substantive requirements of such permits or approvals. The amended AO also requires that the exempt permits or approvals and the applicable substantive requirements of those permits or approvals, as they are known at the time of entry of the AO, be identified.

Permitting for the development projects is underway or completed and, therefore, no IA-specific permits or approvals are needed. Table 2 contains the permits that have been received or are in process for each of the projects.

5 REPORTING

Upon completion of the IA work, a final IA Report, describing the methods and outcome of the IA, will be prepared and submitted to Ecology for review and comment. The final IA report will include an O&M plan for the constructed caps.

6 SCHEDULE

The Port will conduct the IAs as three construction phases. It is anticipated that the construction activities will be conducted in 2016.

The current schedule for the IA is as follows:

1. A Monitoring Plan for Indoor Air will be prepared and implemented prior to occupation of the AAM building and incorporated into the final site-wide Cleanup Action Plan. The Port bidding process for the AAM building will be performed in March 2016.
2. AAM building construction will be initiated in April 2016 and a construction period of 10 months is anticipated.
3. AAM launch route construction will be constructed during a later phase (anticipated to start in October 2016).
4. The Port bidding process for the C Street Terminal Project will be performed in May 2016.
5. C Street Terminal construction is anticipated to begin in July 2016, with an approximate 4-month construction period anticipated; construction shall be complete by October 2016.

The Port shall prepare, for Ecology review and approval, a final IA Completion Report within 90 days following the completion of the IA construction. The IA Completion Report will include an O&M plan for the constructed caps.

7 INTEGRATION WITH FINAL CLEANUP ACTION

The combination of permanent source removal, capping, and landfill gas control achieved through the IAs is designed to be consistent with, and not preclude, alternatives for the final Site cleanup action as required under WAC 173-340-430(3)(b). Source control is the first and most important step for controlling potential migration of contaminants to on-Site and off-Site receptors and, therefore, this will be a key requirement for the final cleanup action. The IAs will be assessed for integration into the final Site cleanup action, which will be completed following finalization of the RI/FS and Ecology's issuance of a Cleanup Action Plan.

By permanently removing contaminated soil and building materials from the Site and ensuring long-term inspection and maintenance, the IAs will also support the Port's planned Site redevelopment and long-term Site use.

8 REFERENCES

Ecology (Washington State Department of Ecology), 2006. *In the Matter of Remedial Action by the Port of Bellingham and the City of Bellingham*. Agreed Order No. DE 3441 issued by Washington State Department of Ecology. September 2006.

Ecology, 2012a. *In the Matter of Remedial Action by the Port of Bellingham and the City of Bellingham*. First Amendment to Agreed Order No. DE 3441 issued by Washington State Department of Ecology. 2012.

Ecology, 2012b. *Stormwater Management Manual for Western Washington*. Publication Number 12-10-030. August 2012.

TABLES

**Table 1
Soil Cleanup Levels**

Analyte (by Group)	Cleanup Level for Unrestricted Land Use - Unsaturated Soil (mg/kg)		Cleanup Level for Unrestricted Land Use - Saturated Soil (mg/kg)	
	Value	Basis ¹	Value	Basis ¹
Total Petroleum Hydrocarbons (TPH)				
Gasoline Range Hydrocarbons	30	(mA)	30	(mA)
Diesel Range Hydrocarbons	2000	(mA)	2000	(mA)
Oil Range Hydrocarbons	2000	(mA)	2000	(mA)
Total TPHs	2000	(mA)	2000	(mA)
Heavy Metals				
Arsenic	20	(mA)	20	(mA)
Cadmium	1.2	(gwl-u)	2	(mA)
Chromium (Total)	5200	(gwl-u)	260	(gwl-s)
Chromium (VI)	48	(back)	48	(back)
Copper	36	(back)	36	(back)
Lead	250	(mA)	250	(mA)
Mercury	2	(gwl-u)	0.1	(gwl-s)
Nickel	48	(back)	48	(back)
Selenium	7.4	(gwl-u)	1	(pql)
Silver	0.32	(gwl-u)	0.02	(pql)
Zinc	100	(gwl-u)	85	(back)
Volatile Organic Compounds				
Benzene	0.034	(gwl-u)	0.005	(pql)
Polycyclic Aromatic Hydrocarbons (PAHs)				
Acenaphthene	2.5	(gwl-u)	0.13	(gwl-s)
Anthracene	34	(gwl-u)	1.7	(gwl-s)
Fluoranthene	25	(gwl-u)	1.3	(gwl-s)
Fluorene	3.6	(gwl-u)	0.18	(gwl-s)
Pyrene	160	(gwl-u)	8	(gwl-s)
1-Methylnaphthalene	35	(mB)	35	(mB)
2-Methylnaphthalene	320	(mB)	320	(mB)
Naphthalene	16	(gwl-u)	0.8	(gwl-s)
Benz(a)anthracene	1.1	(gwl-u)	0.056	(gwl-s)
Benzo(a)pyrene	0.14	(mB)	0.14	(mB)
Benzo(b)fluoranthene	1.4	(mB)	0.19	(gwl-s)
Benzo(k)fluoranthene	3.7	(gwl-u)	0.19	(gwl-s)
Chrysene	1.2	(gwl-u)	0.062	(gwl-s)
Dibenzo(a,h)anthracene	0.14	(mB)	0.14	(mB)
Indeno(1,2,3-cd)pyrene	1.4	(mB)	0.55	(gwl-s)
Total cPAHs TEQ	0.14	(mB)	0.14	(mB)
Other Semi-volatile Organics				
Bis(2-ethylhexyl) phthalate	17	(gwl-u)	0.86	(gwl-s)

Notes:

1. Soil cleanup levels are based on Table 4-2a of the RI (Anchor QEA 2015) for unrestricted land use. Cleanup levels are the most stringent value, protective of all exposure pathways, adjusted upward for background or Method A criteria.
2. Soil cleanup levels based on protection of groundwater may be adjusted based on site-specific leaching tests during development of the cleanup action plan, during remedial design, or during compliance monitoring.

(back) = Natural Background

(gwl-s) = Saturated Soil Concentration Protective of Leachability to Groundwater for Unrestricted Land Use

(gwl-u) = Unsaturated Soil Concentration Protective of Leachability to Groundwater for Unrestricted Land Use

(mA) = Soil, Direct Contact, Method A for Unrestricted Land Use

(mB) = Soil, Direct Contact (ingestion only), Method B, Most-Restrictive Standard Formula Value for Unrestricted Land Use

(pql) = Applicable Practical Quantitation Level

cPAHs = carcinogenic polycyclic aromatic hydrocarbons

mg/kg = milligram per kilogram

RI = Remedial Investigation

TEQ = toxic equivalent quotient

Table 2
Permits and Substantive Requirements

Project	Permit	Citation	Status (Approval No.)
C Street Terminal	SEPA – Determination of Compliance with the Planned Action Ordinance	RCW 43.21C.036 and WAC 197-11	Submitted by GeoEngineers. Notice of action has been posted and will become final on March 11, 2016.
	Shoreline Substantive Development Permit	City of Bellingham under SMP, BMC Title 22; RCW 90.58	Submitted by GeoEngineers. Notice of action has been posted and will become final on March 11, 2016.
	Building Permit	City of Bellingham Building Services	Submitted by Wilson Engineering
	Public Facilities Construction Permit	City of Bellingham Public Works	Submitted by Wilson Engineering
	NPDES Construction Stormwater General Permit	Department of Ecology, RCW 90.58	Notice of intent to be submitted by Wilson Engineering
	Major Grading Permit	City of Bellingham Grading Ordinance, BMC Title 16.70	Submitted by Wilson Engineering
All American Marine	SEPA – Determination of Compliance with the Planned Action Ordinance	RCW 43.21C.036 and WAC 197-11	Submitted by Carletti Architects on February 3, 2016 (SEP2016-0004)
	Shoreline Substantive Development Permit	City of Bellingham under SMP, BMC Title 22; RCW 90.58	To be submitted by PSE Survey
	Building Permit	City of Bellingham Building Services	Submitted by Carletti Architects on February 3, 2016 (BLD2016-0079)
	Public Facilities Construction Permit	City of Bellingham Public Works	Submitted by Carletti Architects on February 3, 2016 (PFC2016-0006)
	NPDES Construction Stormwater General Permit	Department of Ecology, RCW 90.58	Notice of intent to be submitted by PSE Survey
	Road Improvements	City of Bellingham	To be submitted by PSE Survey
	Air Operating Permit	Northwest Clean Air Agency (NWCAA) Section 322; RCW 70.94 and WAC 173	Not expected to be required based on anticipated low VOC levels

Notes:

BMC = Bellingham Municipal Code
 NPDES = National Pollutant Discharge Elimination System
 RCW = Revised Code of Washington
 SEPA = State Environmental Policy Act
 SMP = Shoreline Master Program
 VOC = volatile organic compound
 WAC = Washington Administrative Code

FIGURES



Q:\Jobs\120007-01.01_Central_Waterfront_RIFS\Maps\Work_Plan\Vicinity_Map.mxd ckiblinger 2/17/2016 1:54:29 PM

Figure 1

Vicinity Map

C Street Terminal and AAM Building Projects - Interim Action Work Plan

Central Waterfront Site

Port of Bellingham, WA



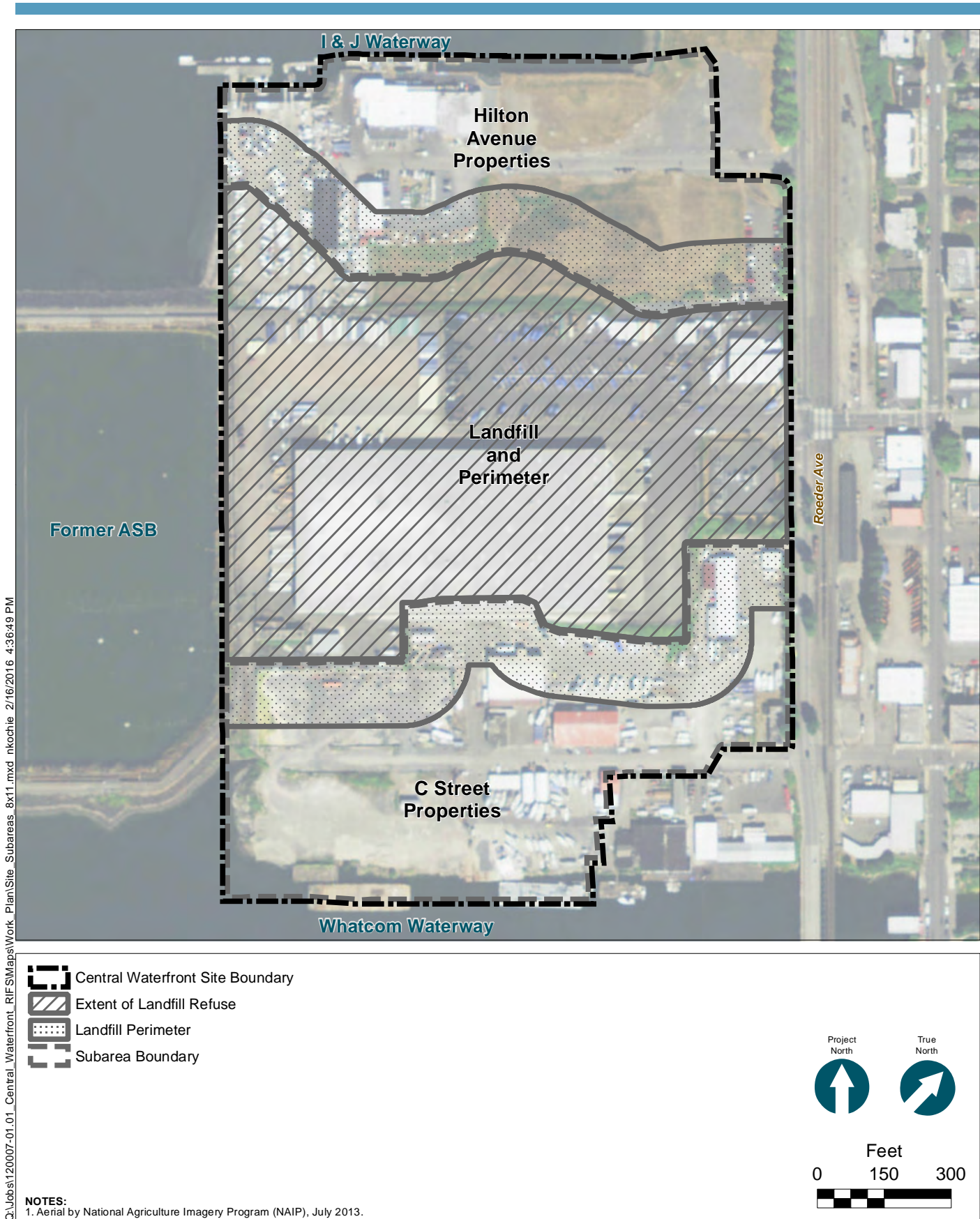

C:\Jobs\120007-01.01_Central_Waterfront_RIFS\Maps\Work_Plan\Site_Subareas_8x11.mxd nkoehie 2/16/2016 4:36:49 PM

Figure 2

Central Waterfront Site Subareas
 C Street Terminal and AAM Building Projects - Interim Action Work Plan
 Central Waterfront Site
 Port of Bellingham, WA



Q:\Jobs\120007-01_01_Central_Waterfront_RIFS\Maps\Work_Plan\Interim_Action_Projects_8x11.mxd nkochie 3/9/2016 3:15:53 PM

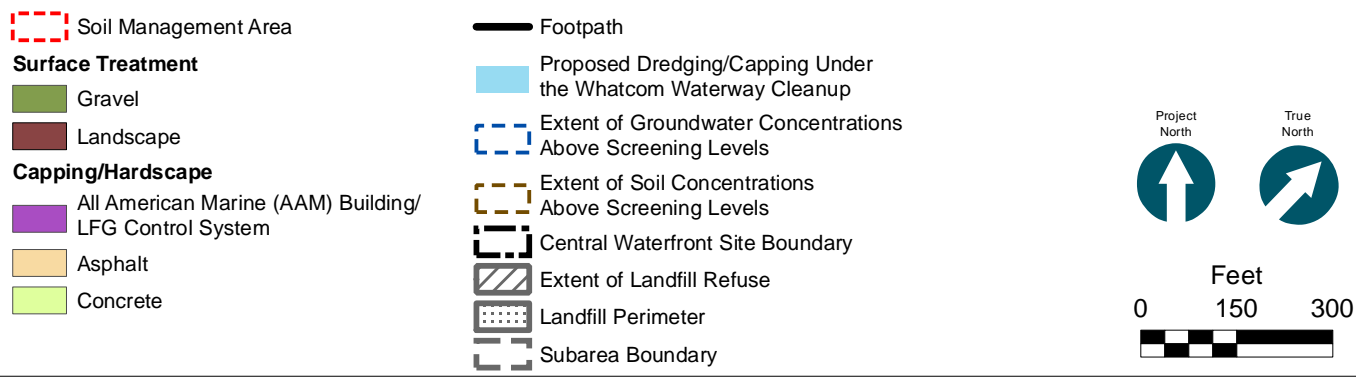
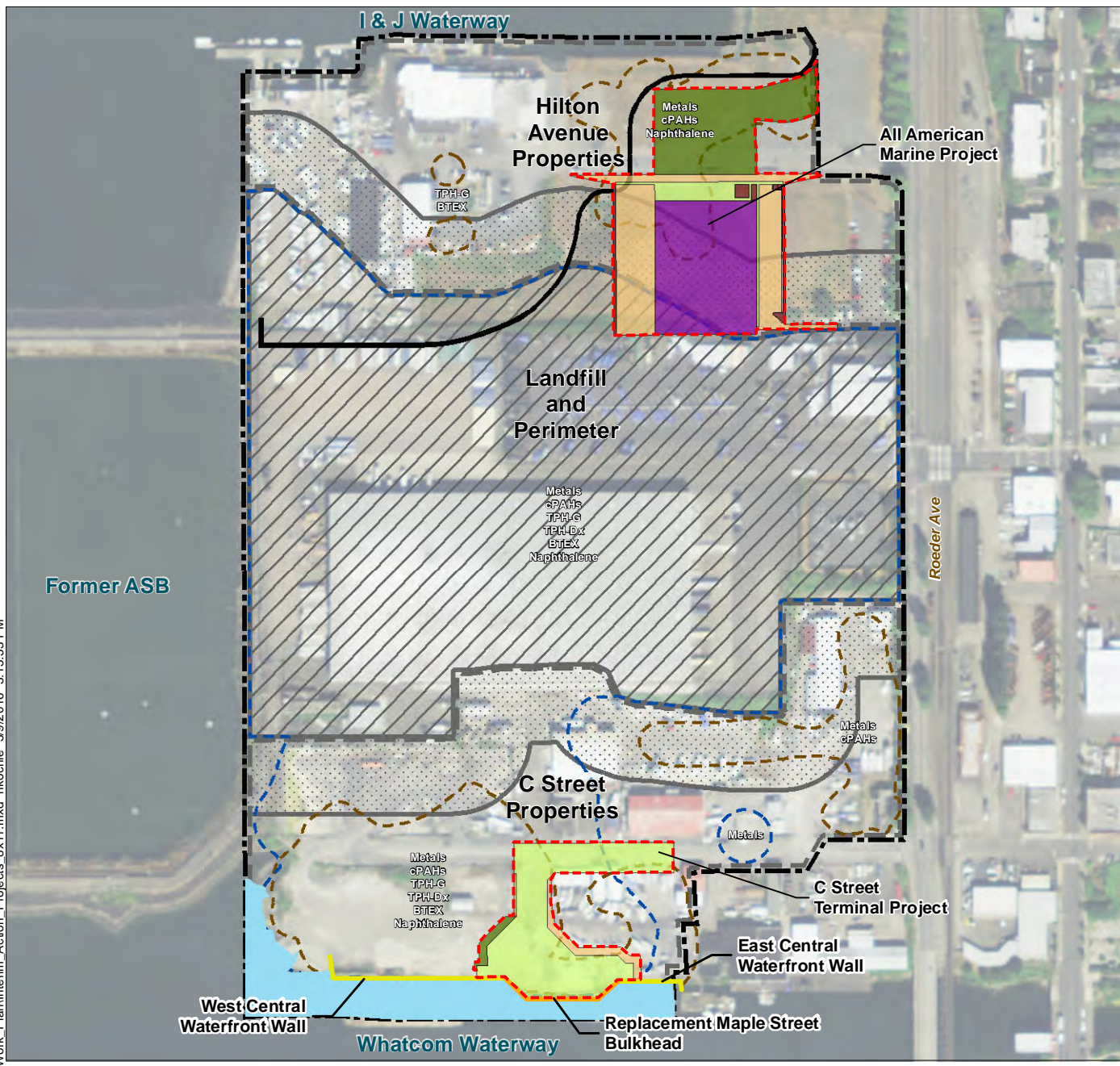

NOTES:
 1. Extent of groundwater and soil concentrations above screening levels derived in the 2015 Central Waterfront Site Remedial Investigation Report (Anchor QEA 2015).
 2. Aerial by National Agriculture Imagery Program (NAIP), July 2013.



Figure 3
 Location of Interim Action Projects
 C Street Terminal and AAM Building Projects - Interim Action Work Plan
 Central Waterfront Site
 Port of Bellingham, WA

Q:\Jobs\120007-01_01_Central_Waterfront_RIFS\Maps\Work_Plan\C_STL_Project_Closeup_8x11L.mxd nkochie 3/9/2016 3:15:31 PM

NOTE:
1. Extent of groundwater and soil concentrations above screening levels derived in the 2015 Central Waterfront Site Remedial Investigation Report (Anchor QEA 2015).

C Street Properties Subarea

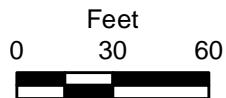
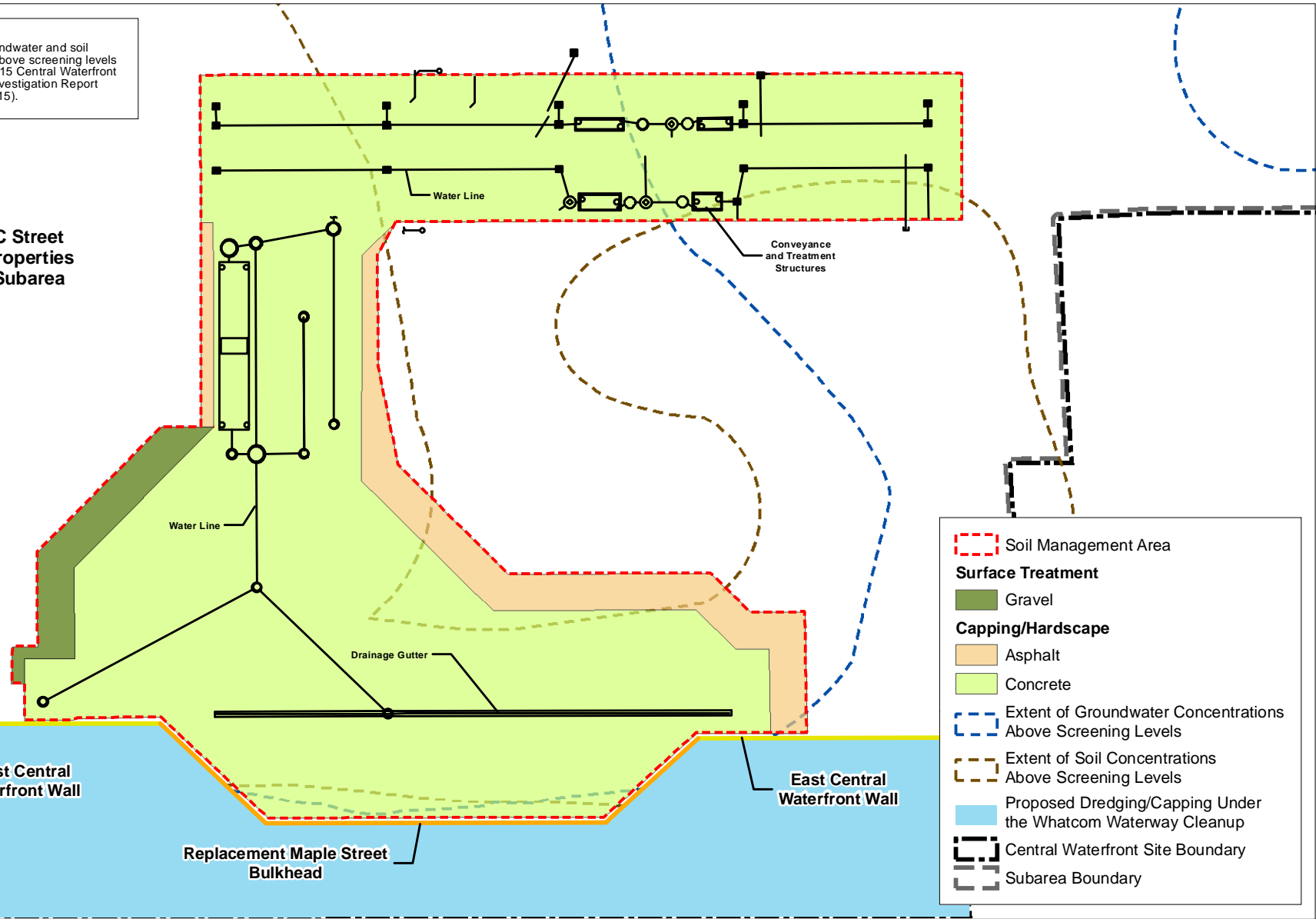
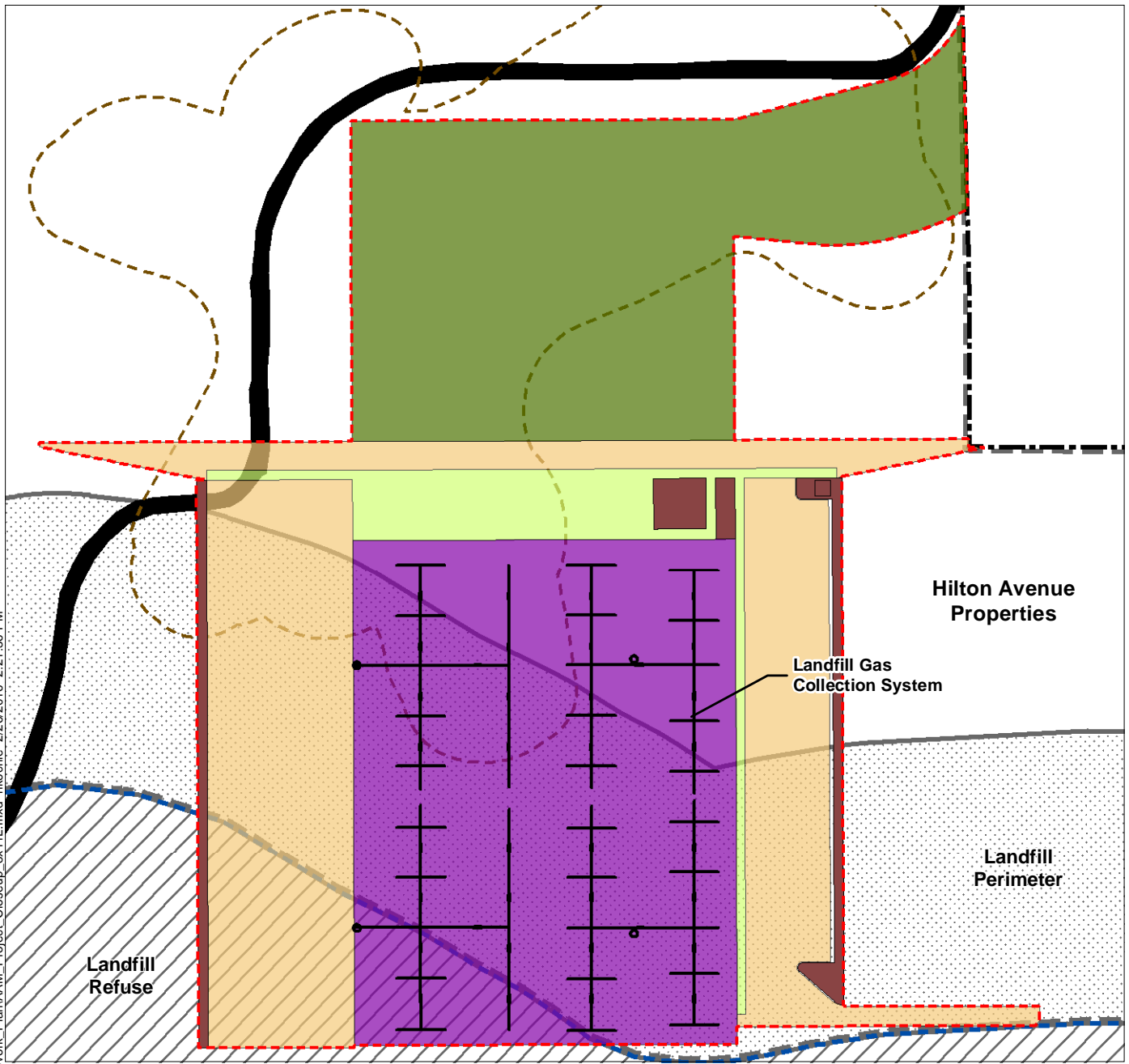

Figure 4
Detailed Remedial Components of C Street Terminal Project
C Street Terminal and AAM Building Projects - Interim Action Work Plan
Central Waterfront Site
Port of Bellingham, WA

C:\Jobs\120007-01_01_Central_Waterfront_RIFS\Maps\Work_Plan\AAM_Project_Closeup_8x11L.mxd nkoehle 2/26/2016 2:21:36 PM



Soil Management Area

Surface Treatment

- Gravel
- Landscape

Capping/Hardscape

- All American Marine (AAM) Building/ LFG Control System
- Asphalt
- Concrete

Footpath

Extent of Groundwater Concentrations Above Screening Levels

Extent of Soil Concentrations Above Screening Levels

Central Waterfront Site Boundary

Extent of Landfill Refuse

Landfill Perimeter

Subarea Boundary

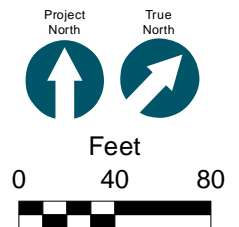

NOTE:
1. Extent of groundwater and soil concentrations above screening levels derived in the 2015 Central Waterfront Site Remedial Investigation Report (Anchor QEA 2015).

Figure 5

Detailed Remedial Components of All American Marine Project
C Street Terminal and AAM Building Projects - Interim Action Work Plan
Central Waterfront Site
Port of Bellingham, WA



ATTACHMENT A LANDFILL GAS CONTROL SYSTEM DESIGN

(Landau Associates 2016)

Technical Memorandum

TO: David Wilson and Peter Carletti, Carletti Architects
FROM: Jeremy Davis and Dave Fischer
DATE: January 26, 2016
RE: **Landfill Gas Control System Design**
All American Marine – Hilton Avenue Building
Bellingham, Washington
Project No. 1582001.010.011

Introduction and Background

This technical memorandum has been prepared to present the design basis and preliminary design information for a landfill gas (LFG) control system that will be incorporated into the construction of the proposed All American Marine building (AAM Building) along Hilton Avenue in the Central Waterfront area at the Port of Bellingham in Bellingham, Washington (Figure 1).

A portion of the proposed building site is located over the former Roeder Avenue Landfill (Landfill; Figure 2). The Landfill reportedly contains municipal solid waste (MSW) that was disposed in the 1960s and 1970s. As the buried waste decomposes, LFG is released which requires a ventilation pathway to leave the subsurface, or it could accumulate to unsafe or unhealthy levels. Because the construction of a building on or adjacent to the Landfill could trap LFG by obstructing the ventilation pathway, a mitigation system is planned to be constructed beneath the building slab to provide ventilation and prevent LFG from entering the building envelope.

Landfill Characteristics

According to information from a remedial investigation conducted at the Landfill in 2001 (ThermoRetec Consulting Corporation 2001¹), the Landfill was in operation between the dates of 1965 and 1974. Reportedly, approximately 235,000 tons of municipal solid waste and wood waste were deposited within the Landfill, which spans an area of approximately 21.4 acres. We understand from the 2001 report that the average waste thickness is approximately 14 feet (ft), though may vary significantly in thickness throughout the area. As shown on Figure 2, the waste extends beneath a portion of the proposed AAM building footprint.

Landfill Gas Production Rate

The rate of LFG generation during anaerobic waste decomposition typically peaks shortly after waste has been placed in a landfill (1 to 4 years after placement is typical), then declines at an exponential rate as microbes deplete the available degradable material. LFG is primarily composed of methane,

¹ ThermoRetec Consulting Corporation. 2001. *Remedial Investigation and Feasibility Study, Roeder Avenue Landfill, Bellingham, Washington*. October.

carbon dioxide, and water vapor. Methane is typically present in LFG at significant concentrations (30 to 60 percent, depending on the age of the waste) and is an explosion hazard at concentrations between 5 percent by volume (its lower explosive limit) and 15 percent by volume (its upper explosive limit). Carbon dioxide is also present in LFG at significant concentrations which can pose an asphyxiation hazard by displacing air in confined spaces. Other compounds, such as oxygen, ammonia, sulfide, hydrogen, carbon monoxide, and non-methane organic compounds (NMOCs) are typically present in LFG at lower concentrations (generally making up less than 1 percent by volume) and are usually adequately addressed by mitigation measures designed to address methane. If the cover material restricts vertical migration, the gas can travel laterally underground, which can present health and safety concerns if it enters nearby structures. As a result, efforts are required to prevent the accumulation or migration of LFG, even for aged landfills such as the subject Landfill, which likely produces relatively little LFG.

Landau Associates used the US Environmental Protection Agency (EPA) LandGEM first order decay rate model with Air Pollutant Emissions Factors (AP-42; EPA 2015²) default parameters to estimate the gas generation potential at the Landfill based on the waste placement information in the 2001 ThermoRetec report. The modeling input and results are presented in Appendix A. Figure 3 graphically presents the estimated total LFG and methane production rates for the years 1965 through 2030 in cubic feet per minute (cfm). The model estimates that most of the LFG produced by the Landfill was likely released to the atmosphere long ago, and that peak generation, which likely occurred in the early to mid-1970s, was less than 200 cfm. The model estimates that LFG production has declined exponentially since that time to the current generation rate of about 25 cfm. Although this rate of production is relatively low, if the LFG is not provided with a ventilation route to the atmosphere, it could accumulate to unsafe or unhealthy concentrations. Based on the estimated LFG generation rate and the Landfill area of 21.4 acres, we estimate the surface flux of LFG is approximately 2.7×10^{-5} cfm/square ft (SF). Although much of the building footprint is outside of the waste boundary, based on its close proximity and because the Landfill does not contain source LFG controls, this surface flux is assumed to be applied to the building footprint of approximately 51,200 SF. Based on these considerations, the mitigation system should be designed to provide ongoing ventilation and protection for 1.4 cfm of LFG.

Landfill Gas Control System Recommendations

As shown on Figure 4, the building slab is approximately 51,200 SF in area. Current site conditions allow LFG in the soil to ventilate slowly to the atmosphere. After constructing the building slab, the surface will be relatively impermeable and buildup of LFG could occur. Also shown on Figure 4, construction of the building foundation will include a system of grade beams below the building floor

² EPA. 2015. *AP 42, Fifth Edition, Volume 1, Chapter 2: Solid Waste Disposal*. Available at: <http://www3.epa.gov/ttn/chief/ap42/ch02/index.html>. Accessed on January 18.

slab. We understand the grade beams will extend approximately 3 ft below the floor slab. This type of building foundation could trap rising LFG in the rectangular “cells” created by the grade beams and perimeter footings. As a result, the LFG control system will need to provide a ventilation pathway for each of the isolated “cells” created by the foundation system.

The proposed LFG control system will generally consist of four components:

1. LFG collection layer (to capture rising LFG and convey it to the strip geocomposite)
2. Strip geocomposite (to convey LFG to vents that discharge above the roofline)
3. Vapor barrier (impermeable liner below the building slab to prevent vapor intrusion)
4. LFG vents (a series of vents which connect the strip geocomposite to the atmosphere).

Landfill Gas Collection Layer

The method for designing gas ventilation layers for LFG collection was developed by Thiel in 1998 (Thiel 1998³, Thiel and Narejo 2005⁴). The method develops the required transmissivity of the collection layer to provide sufficient flow capacity to ventilate a given surface flux of gas based on the maximum allowable build-up of pressure within the system, and the spacing of pipes or strip geocomposites which connect to atmospheric conditions through direct vents. Based on an assumed strip geocomposite spacing of 25 ft, and the surface flux of LFG discussed above, a gas collection layer with a water transmissivity value of 2.6×10^{-4} m²/second is sufficient. This value has been converted from the calculated gas transmissivity for ease of specification, and a typical reduction factor of safety has been applied based on potential reductions in transmissivity from moisture or biological fouling after installation. A typical double-sided geonet/geotextile geocomposite will meet this ventilation requirement. This preliminary design includes this geocomposite being installed beneath the entire footprint of the building, as shown in plan-view on Figure 5, with typical section view details provided on Figure 6.

It is possible that the gravel layer to be placed beneath this building floor slab would be sufficient to meet the transmissivity requirement. However, the gravel layer specification was not available for our review at this time. If sub-slab ventilation were to rely on the gravel layer, its in-place transmissivity would need to be verified. A vapor barrier will be placed over the ventilation layer, and if the gravel is comprised of angular or subangular rock, construction activities on top of the vapor barrier could compromise the barrier by creating pinholes or tears. As a result, a geotextile cushion below the vapor barrier would be recommended for protection of the barrier, even if the gravel layer transmissivity might be considered sufficient. Based on installing a geocomposite with a 6 ounce per

³ Thiel, R.S. 1998. Design Methodology for a Gas Pressure Relief Layer Below a Geomembrane Landfill Cover to Improve Slope Stability.” In *Geosynthetics International*, Vol. 5, No. 6.

⁴ Thiel, Richard and Dhani Narejo. 2005. “Update on designing with geocomposite drainage layers in landfills—Part 2 of 4: geocomposites on bioreactor landfill sideslopes to control seeps and gas.” In *GFR Magazine*, Vol. 23, No. 2.

square yard geotextile bonded to both sides of a 200-mil HDPE geonet, we estimate the materials and installation for the geocomposite collection layer will be approximately \$0.45 to \$0.60 per SF, for a total of \$30,000.

Strip Geocomposite

Strip geocomposites are recommended to carry gas from the LFG collection layer to the LFG vents. This could also be accomplished with perforated piping installed in trenches dug into the sub-slab gravel layer. However, use of strip geocomposites instead of perforated piping provides a significant cost savings due to the ease of installation. Instead of trenching, installing the piping, and backfilling, a square-nosed shovel can be used to create a 12-inch wide and 1-inch deep channel that the strip geocomposite can be placed into.

Figure 5 shows the layout for the approximately 1,900 ft of strip geocomposite included in this preliminary design. Figure 6 shows the preliminary details for the installation of this material beneath the LFG collection layer. Pipe adapter fittings will connect the strip geocomposites to 2-inch-diameter pipes that will be embedded into the grade beams. We estimate the strip geocomposite will cost approximately \$1.10 per linear ft, and approximately \$5.00 per end pipe connection, for a total material cost of about \$3,000 and a likely total installed cost of under \$10,000.

Vapor Barrier

A vapor barrier will be installed beneath the building floor slab as shown on Figure 5. Typical details for the vapor barrier installation are provided on Figure 6. The barrier will be installed throughout the entire building footprint, overlapping the grade beams and perimeter footings by 2 inches. Based on its performance characteristics and ease of installation, the preliminary design includes the use of a polyolefin vapor barrier, which has very low permeance to methane, and exceeds the ASTM International E 1745 Class A specification for water vapor permeance. The recommended 20-mil Stego® Wrap vapor barrier will be overlapped and sealed using Stego® proprietary tape or mastic, which will also be used for liner penetrations such as utilities that pass through the building slab, and the LFG vents. Product details are provided in Appendix B. We estimate the total cost for materials will be approximately \$0.36/SF. For planning purposes, we assume installation will be approximately \$0.20 per SF, though this cost may vary based on the contractor, the number of penetrations, and weather conditions during installation. If the underlying LFG collection layer is not constructed with geotextile cushion or geocomposite, or if construction quality assurance (CQA) indicates that the vapor barrier could have been compromised during installation, the vapor barrier will be field-tested after installation using a smoke test to observe for leaks. We estimate the total installed cost for the vapor barrier will be approximately \$30,000, which does not include an allowance for CQA or smoke testing activities.

Landfill Gas Vents

As shown on Figure 5, the preliminary design includes 4 LFG vents that will connect the subsurface ventilation system to the atmosphere. The vents will pass through the building interior along an exterior wall, and discharge above the roofline, as shown on Figure 6. Because the temperature inside the building is typically higher than subsurface vapors, the gas is warmed in the ventilation pipes creating a stack-effect which aids in ventilation and limits condensation within the vent. Inside the building, the vent pipe will pass through a small wall-mounted cabinet which houses an isolation valve and monitoring port to be used for future gas monitoring purposes. Above the roofline, wind turbines will be installed at the terminal end of the vent which rotate in the wind to provide additional ventilation assistance to maintain slightly lower pressures beneath the slab, reducing the driving forces which can cause vapor intrusion. It is not expected that the wind turbines will decrease the pressure enough to affect subsurface soil conditions except immediately beneath the slab in the LFG collection layer. The wind turbines specified in the preliminary design are suitable for corrosive environments. Product information for the wind turbines is included in Appendix B. For planning purposes, we estimate the total installed cost for the LFG vents will be approximately \$3,000 per vent, for a total of \$12,000.

Additional Considerations

In addition to the ventilation and sealing of the building slab that will be provided by the LFG control system described above, additional requirements will be provided in the subsequent system design to prevent vapor intrusion at utility penetrations. These will include recommendations for sealing the utility penetrations and plugging utility trenches within 5 ft of the building foundation to prevent LFG from entering the building via conduits or utility bedding/backfill materials.

As part of CQA, LFG monitoring should be conducted in the building prior to occupancy to confirm the adequacy of the system to prevent LFG intrusion. We recommend that conditions be monitored with a flame ionization detector on two occasions during falling barometric pressure, with the building windows and doors closed. If the mitigation system is constructed as presented in this preliminary design and its effectiveness is confirmed, it is not anticipated that long-term continuous building monitors will be required. Additionally, we recommend that LFG conditions be monitored during subsurface excavation activities (such as for building footings and grade-beams), to confirm construction safety.

We currently estimate the total cost of the LFG control system as described above is approximately \$82,000. This total does not include design, construction contingencies, bidding support, or CQA observations and reporting.

Limitations

This document has been prepared for the use of Carletti Architects for specific application to the All American Marine Hilton Avenue Building in Bellingham, Washington. None of the information, conclusions, and recommendations included in this document can be used for any other project without the express written consent of Landau Associates. Further, the reuse of information, conclusions, and recommendations provided herein for extensions of the project or for any other project, without review and authorization by Landau Associates, shall be at the user's sole risk. Landau Associates warrants that within the limitations of scope, schedule, and budget, our services have been provided in a manner consistent with that level of care and skill ordinarily exercised by members of the profession currently practicing in the Pacific Northwest under similar conditions as this project. We make no other warranty, either express or implied.

LANDAU ASSOCIATES, INC.

Jeremy Davis, PE, CHMM
Associate Engineer

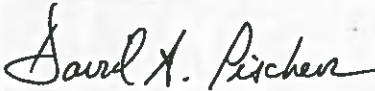

Dave Fischer, PE
Principal

JMD/DAP/kes

[P:\1582\001\REV\JANUARY 26 REVISION\REVISED AAM BUILDING - LFG CONTROL TECHNICAL MEMORANDUM.DOCX]

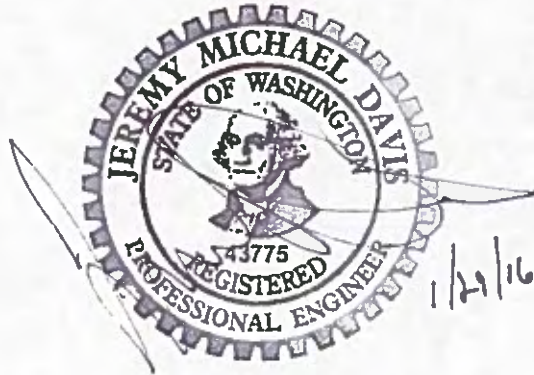

Attachments

- Figure 1 – Vicinity Map
- Figure 2 – Site Plan
- Figure 3 – Roeder Avenue Landfill Gas Production Rate
- Figure 4 – AAM Building Floor Plan
- Figure 5 – LFG Collection System Layout
- Figure 6 – LFG Collection System Details
- Appendix A – Roeder Avenue Landfill LandGEM Landfill Gas Emissions Model
- Appendix B – Landfill Gas Control System Product Details

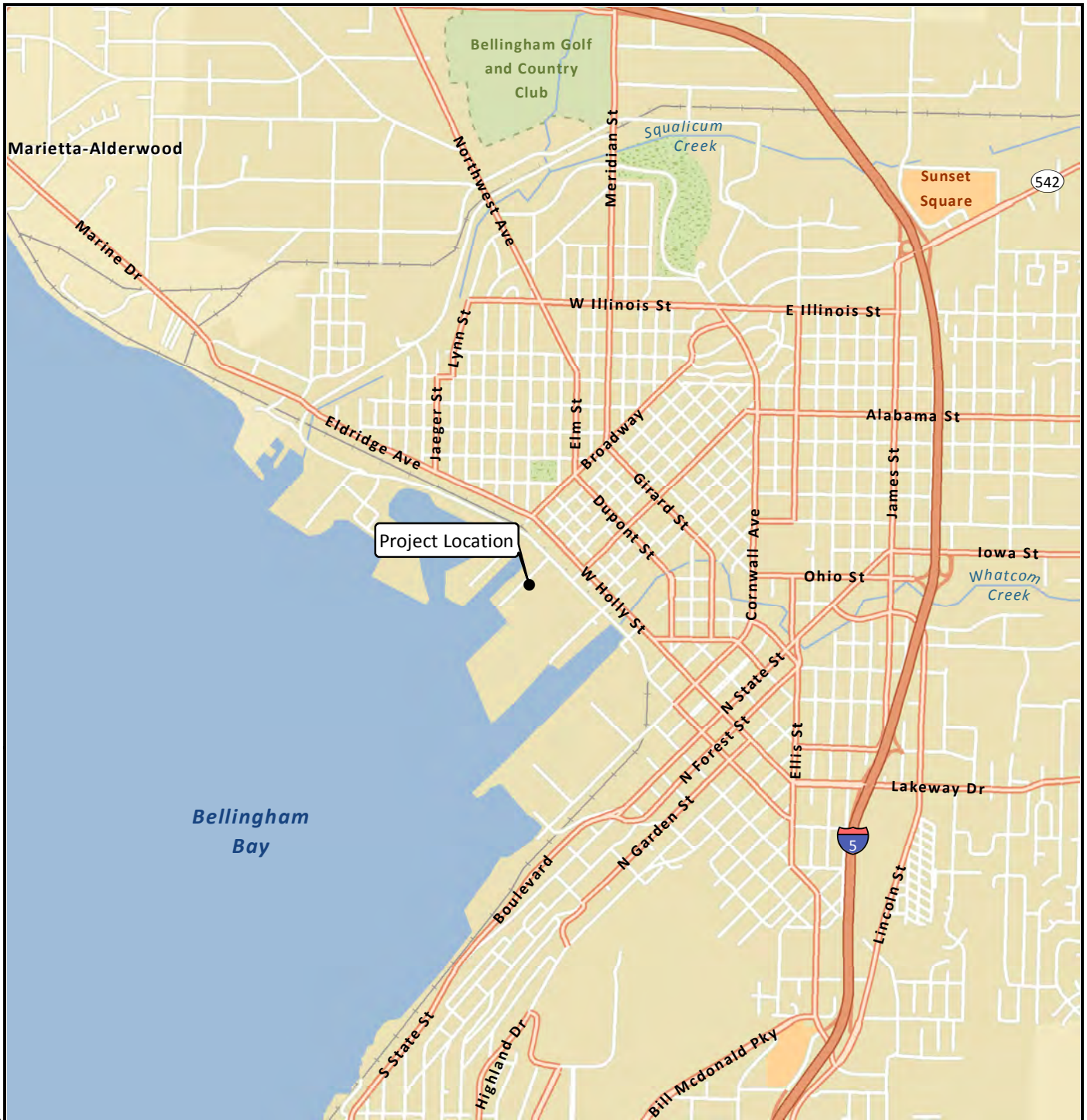

G:\Projects\1582\001\010\F01 VicinityMap.mxd 4/26/2016

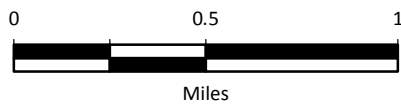

Data Source: Esri 2012



All American Marine
Hilton Avenue Building
Bellingham, Washington

Vicinity Map

Figure
1

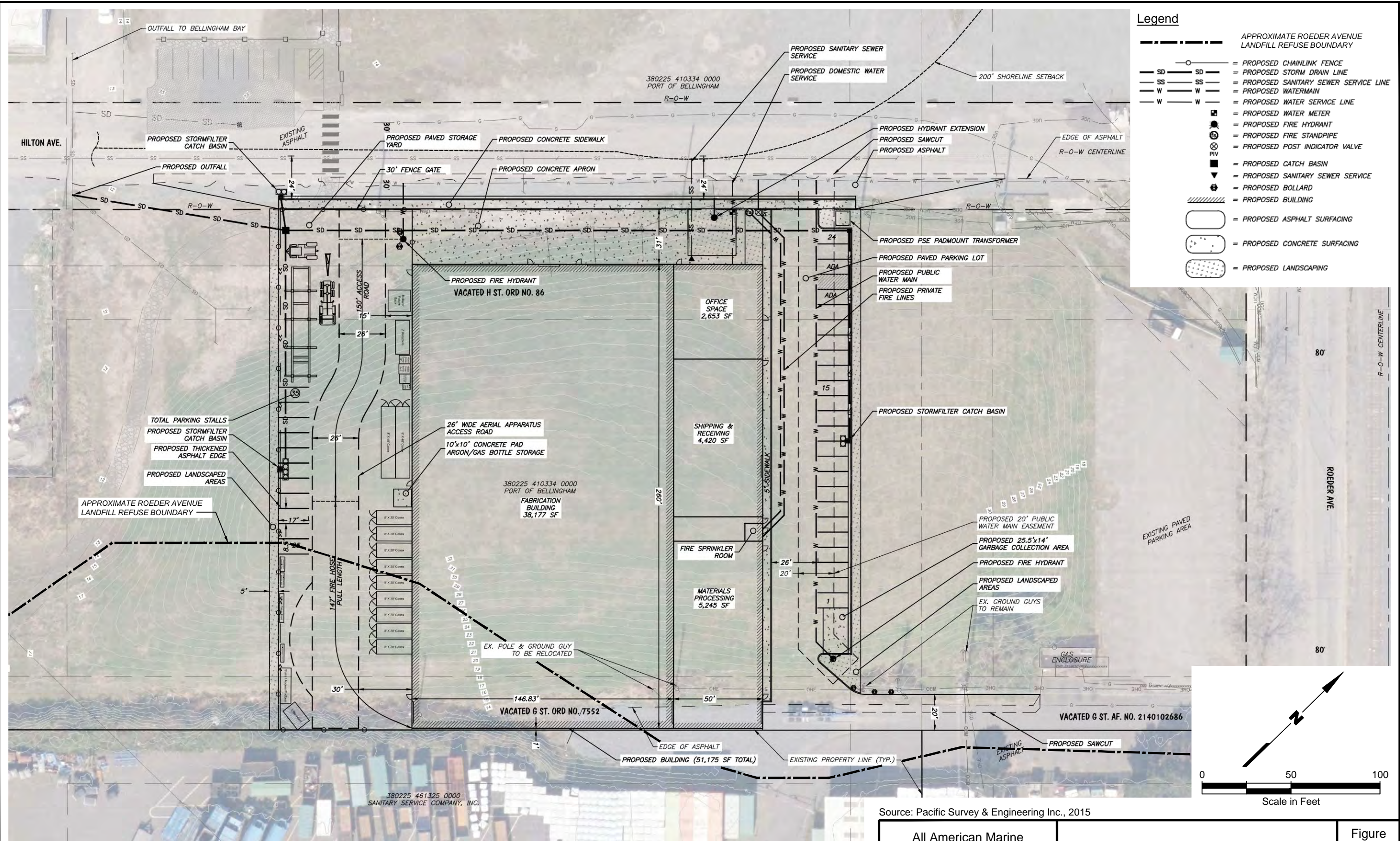

Source: Pacific Survey & Engineering Inc., 2015

All American Marine
Hilton Avenue Building
Bellingham, Washington

Site Plan

Figure
2

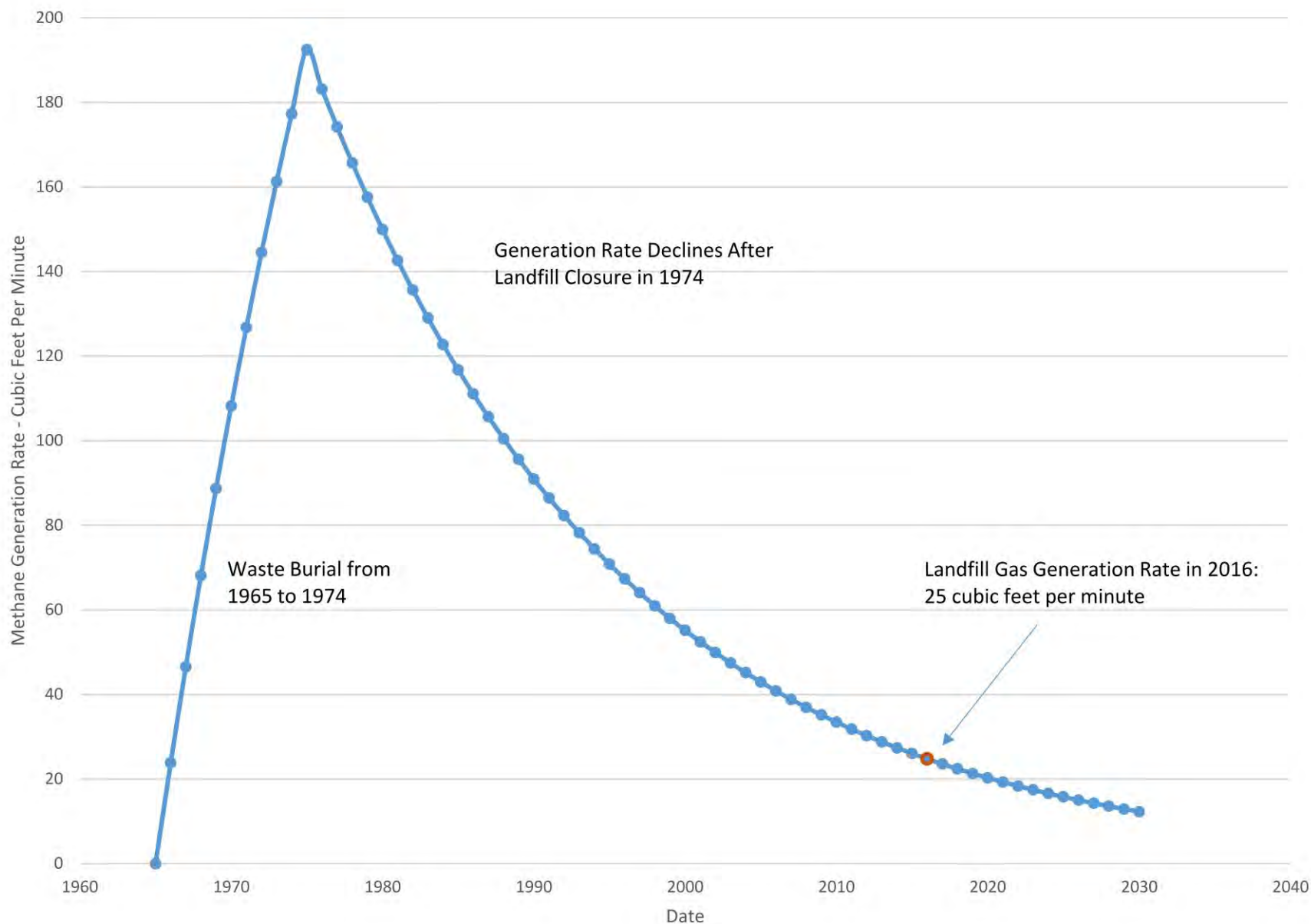

LANDAU ASSOCIATES, INC. | G:\Projects\1582\00\10\10\TechMemo\F04 BuildingFloorPlan.dwg (A) - Figure 4 - 1/27/2016

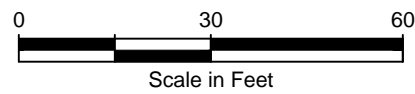
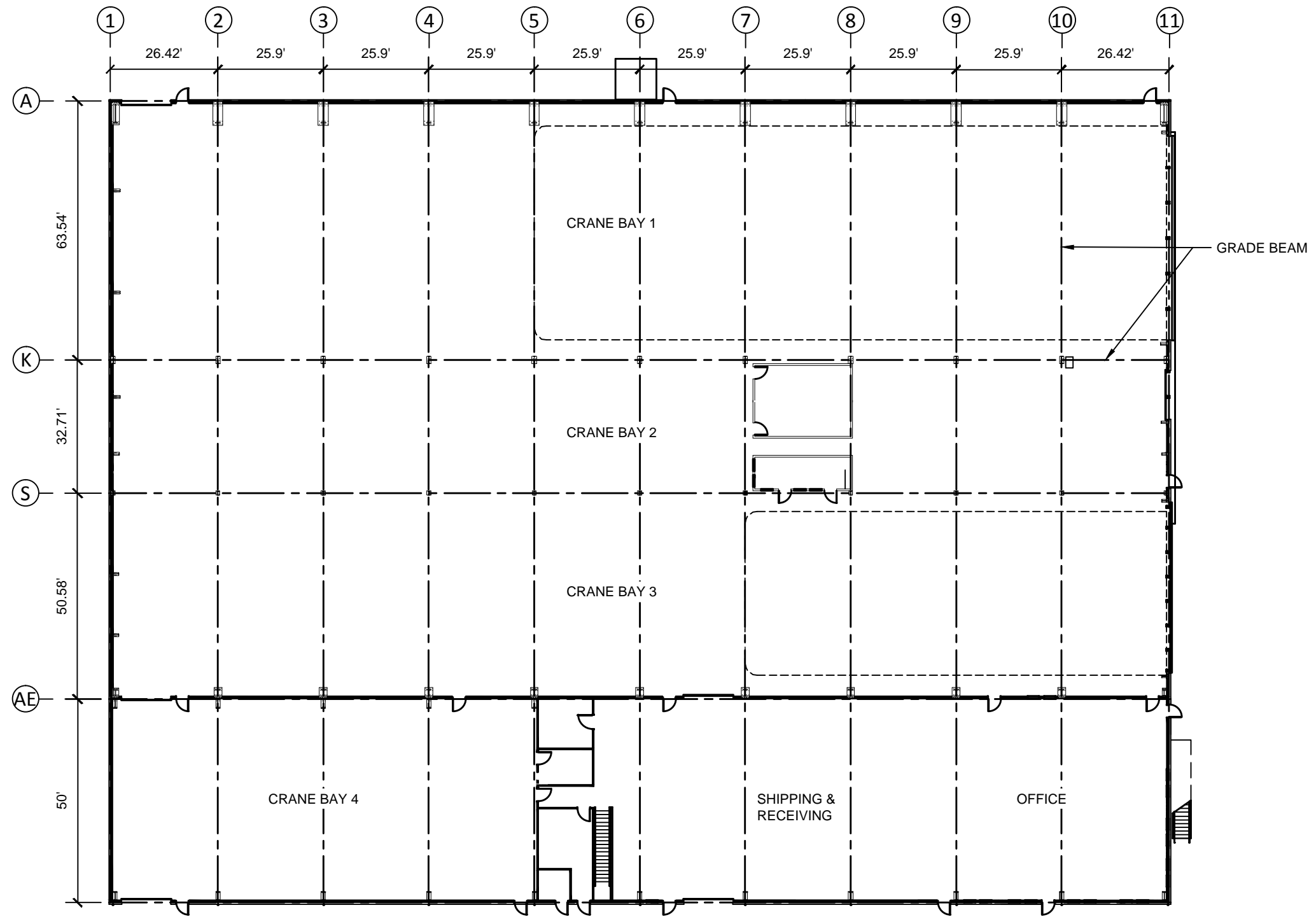
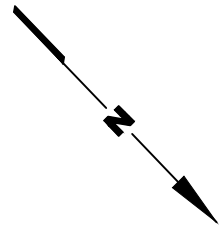

Source: Carletti Architects P.S., 2015

All American Marine
Hilton Avenue Building
Bellingham, Washington

AAM Building Floor Plan

Figure
4

LANDAU ASSOCIATES, INC. | G:\Projects\1582\001\010\TechMemo\F05 LFG Collection\SystemLayout.dwg (A) -Figure 5- 1/29/2016

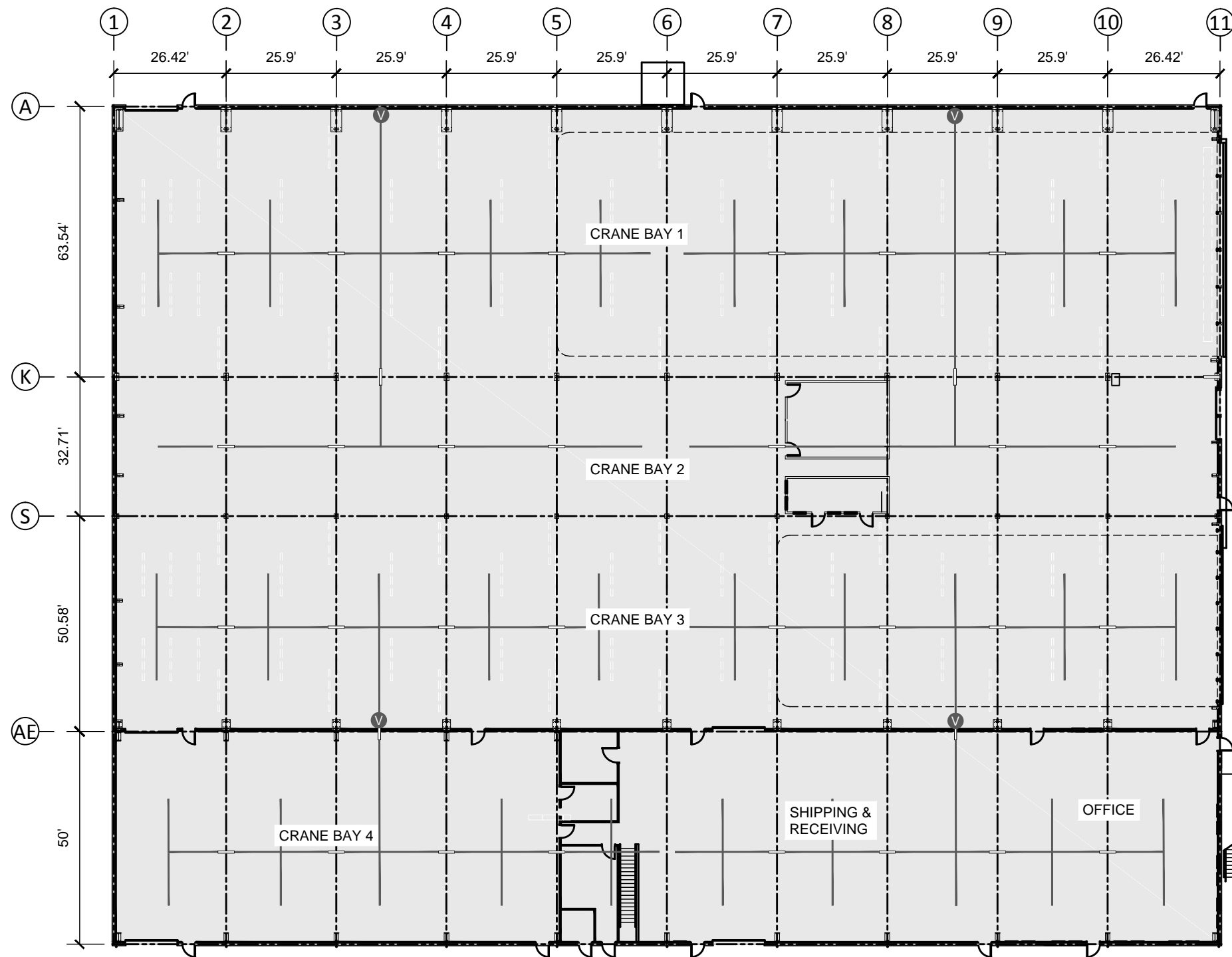
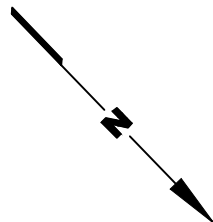

- Legend**
- Vent pipe location
 - Strip geocomposite
 - Pipe penetration through internal grade beam
 - Limits of LFG collection layer (Geocomposite) and vapor barrier
 - Grade beam

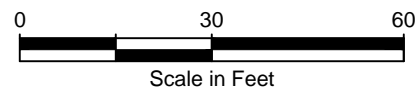

Source: Carletti Architects P.S., 2015

All American Marine
Hilton Avenue Building
Bellingham, Washington

LFG Collection System Layout

Figure
5

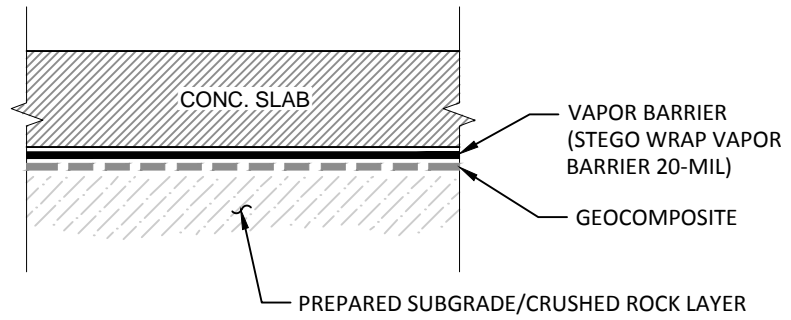

1 TYPICAL LFG VENTILATION LAYER AND BARRIER BELOW SLAB
N.T.S.

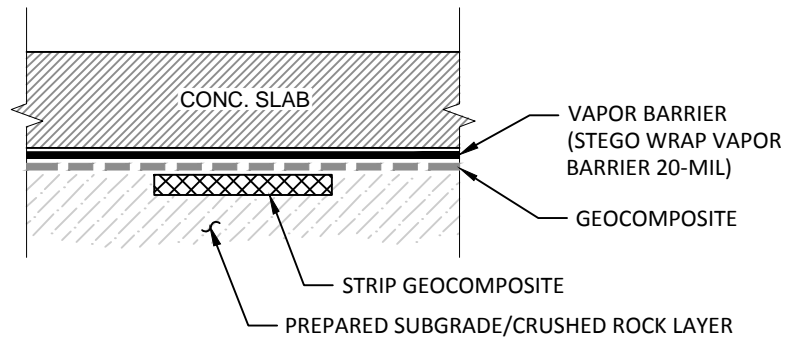

2 TYPICAL LFG VENTILATION AND BARRIER WITH STRIP GEOCOMPOSITE
N.T.S.

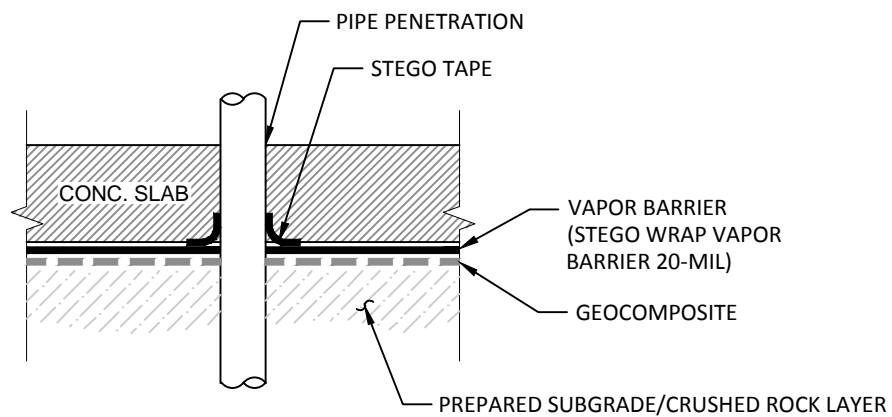

3 TYPICAL VAPOR BARRIER PENETRATION
N.T.S.

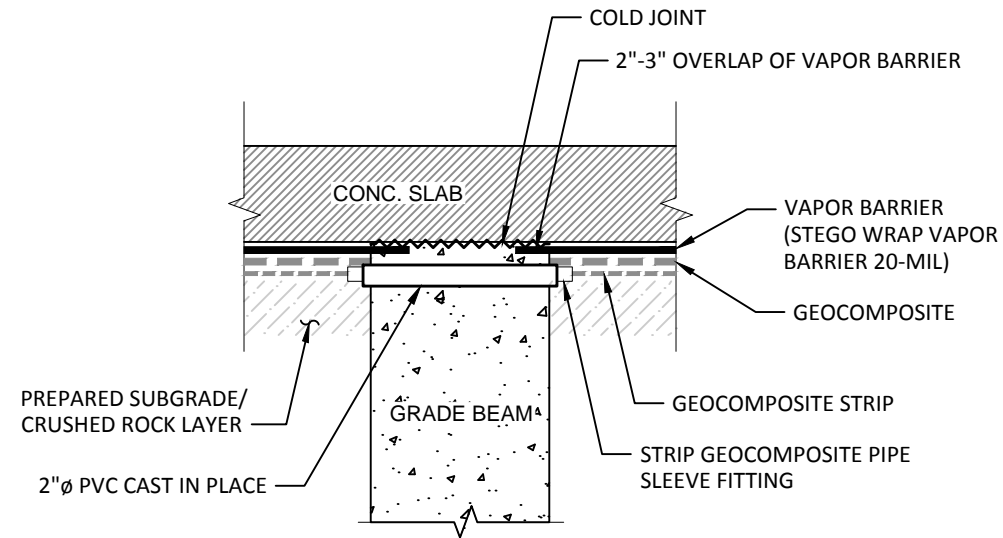

4 TYPICAL LFG CONDUIT PENETRATION AT GRADE BEAM
N.T.S.

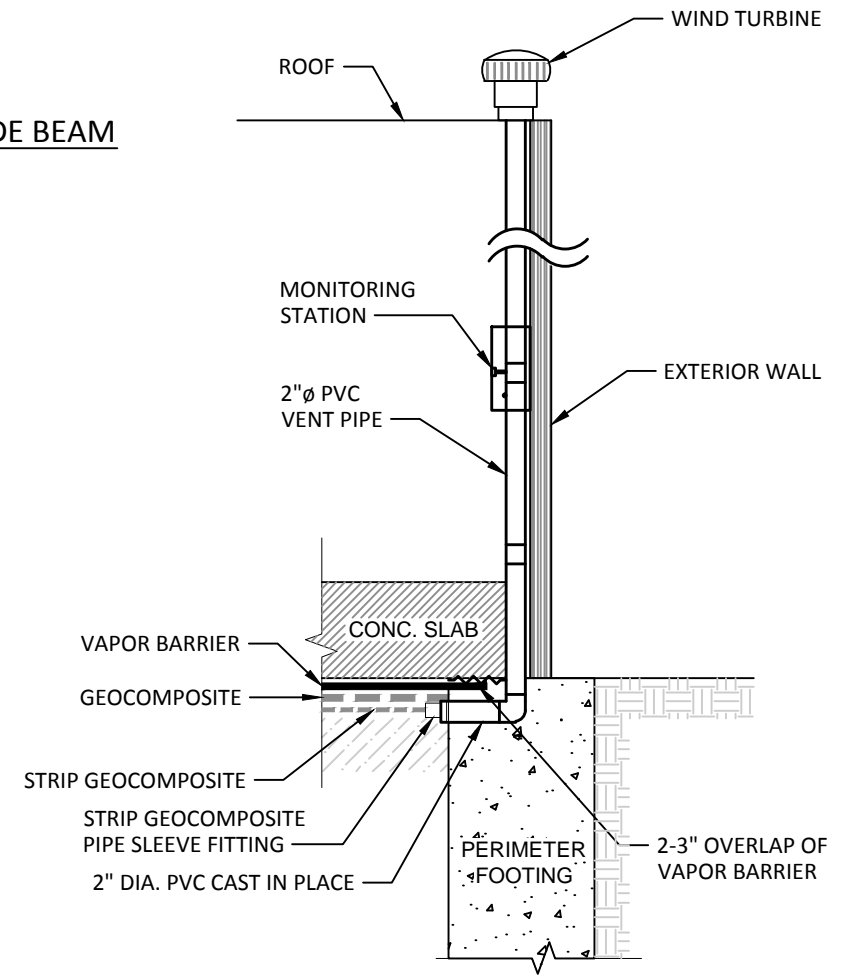

5 TYPICAL VENT PIPE PENETRATION
N.T.S.

LANDAU ASSOCIATES, INC. | G:\Projects\1582\001\010\TechMemo\F06 Details.dwg (A) "Figure 6" 1/27/2016

Roeder Avenue Landfill LandGEM Landfill Gas Emissions Model



Summary Report

Landfill Name or Identifier: Roeder Avenue Landfill

Date: Monday, January 18, 2016

Description/Comments:

About LandGEM:

First-Order Decomposition Rate Equation:

$$Q_{CH_4} = \sum_{i=1}^n \sum_{j=0.1}^1 kL_o \left(\frac{M_i}{10} \right) e^{-kt_{ij}}$$

Where,

Q_{CH_4} = annual methane generation in the year of the calculation ($m^3/year$)

i = 1-year time increment

n = (year of the calculation) - (initial year of waste acceptance)

j = 0.1-year time increment

k = methane generation rate ($year^{-1}$)

L_o = potential methane generation capacity (m^3/Mg)

M_i = mass of waste accepted in the i^{th} year (Mg)

t_{ij} = age of the j^{th} section of waste mass M_i accepted in the i^{th} year (*decimal years*, e.g., 3.2 years)

LandGEM is based on a first-order decomposition rate equation for quantifying emissions from the decomposition of landfilled waste in municipal solid waste (MSW) landfills. The software provides a relatively simple approach to estimating landfill gas emissions. Model defaults are based on empirical data from U.S. landfills. Field test data can also be used in place of model defaults when available. Further guidance on EPA test methods, Clean Air Act (CAA) regulations, and other guidance regarding landfill gas emissions and control technology requirements can be found at <http://www.epa.gov/ttnatw01/landfill/landflpg.html>.

LandGEM is considered a screening tool — the better the input data, the better the estimates. Often, there are limitations with the available data regarding waste quantity and composition, variation in design and operating practices over time, and changes occurring over time that impact the emissions potential. Changes to landfill operation, such as operating under wet conditions through leachate recirculation or other liquid additions, will result in generating more gas at a faster rate. Defaults for estimating emissions for this type of operation are being developed to include in LandGEM along with defaults for conventional landfills (no leachate or liquid additions) for developing emission inventories and determining CAA applicability. Refer to the Web site identified above for future updates.

Input Review

LANDFILL CHARACTERISTICS

Landfill Open Year	1965	
Landfill Closure Year (with 80-year limit)	1974	
Actual Closure Year (without limit)	1974	
Have Model Calculate Closure Year?	No	
Waste Design Capacity	235,000	<i>short tons</i>

MODEL PARAMETERS

Methane Generation Rate, k	0.050	<i>year⁻¹</i>
Potential Methane Generation Capacity, L ₀	170	<i>m³/Mg</i>
NMOC Concentration	4,000	<i>ppmv as hexane</i>
Methane Content	50	<i>% by volume</i>

GASES / POLLUTANTS SELECTED

Gas / Pollutant #1:	Total landfill gas
Gas / Pollutant #2:	Methane
Gas / Pollutant #3:	Carbon dioxide
Gas / Pollutant #4:	NMOC

WASTE ACCEPTANCE RATES

Year	Waste Accepted		Waste-In-Place	
	(Mg/year)	(short tons/year)	(Mg)	(short tons)
1965	21,364	23,500	0	0
1966	21,364	23,500	21,364	23,500
1967	21,364	23,500	42,727	47,000
1968	21,364	23,500	64,091	70,500
1969	21,364	23,500	85,455	94,000
1970	21,364	23,500	106,818	117,500
1971	21,364	23,500	128,182	141,000
1972	21,364	23,500	149,545	164,500
1973	21,364	23,500	170,909	188,000
1974	21,364	23,500	192,273	211,500
1975	0	0	213,636	235,000
1976	0	0	213,636	235,000
1977	0	0	213,636	235,000
1978	0	0	213,636	235,000
1979	0	0	213,636	235,000
1980	0	0	213,636	235,000
1981	0	0	213,636	235,000
1982	0	0	213,636	235,000
1983	0	0	213,636	235,000
1984	0	0	213,636	235,000
1985	0	0	213,636	235,000
1986	0	0	213,636	235,000
1987	0	0	213,636	235,000
1988	0	0	213,636	235,000
1989	0	0	213,636	235,000
1990	0	0	213,636	235,000
1991	0	0	213,636	235,000
1992	0	0	213,636	235,000
1993	0	0	213,636	235,000
1994	0	0	213,636	235,000
1995	0	0	213,636	235,000
1996	0	0	213,636	235,000
1997	0	0	213,636	235,000
1998	0	0	213,636	235,000
1999	0	0	213,636	235,000
2000	0	0	213,636	235,000
2001	0	0	213,636	235,000
2002	0	0	213,636	235,000
2003	0	0	213,636	235,000
2004	0	0	213,636	235,000

WASTE ACCEPTANCE RATES (Continued)

Year	Waste Accepted		Waste-In-Place	
	(Mg/year)	(short tons/year)	(Mg)	(short tons)
2005	0	0	213,636	235,000
2006	0	0	213,636	235,000
2007	0	0	213,636	235,000
2008	0	0	213,636	235,000
2009	0	0	213,636	235,000
2010	0	0	213,636	235,000
2011	0	0	213,636	235,000
2012	0	0	213,636	235,000
2013	0	0	213,636	235,000
2014	0	0	213,636	235,000
2015	0	0	213,636	235,000
2016	0	0	213,636	235,000
2017	0	0	213,636	235,000
2018	0	0	213,636	235,000
2019	0	0	213,636	235,000
2020	0	0	213,636	235,000
2021	0	0	213,636	235,000
2022	0	0	213,636	235,000
2023	0	0	213,636	235,000
2024	0	0	213,636	235,000
2025	0	0	213,636	235,000
2026	0	0	213,636	235,000
2027	0	0	213,636	235,000
2028	0	0	213,636	235,000
2029	0	0	213,636	235,000
2030	0	0	213,636	235,000
2031	0	0	213,636	235,000
2032	0	0	213,636	235,000
2033	0	0	213,636	235,000
2034	0	0	213,636	235,000
2035	0	0	213,636	235,000
2036	0	0	213,636	235,000
2037	0	0	213,636	235,000
2038	0	0	213,636	235,000
2039	0	0	213,636	235,000
2040	0	0	213,636	235,000
2041	0	0	213,636	235,000
2042	0	0	213,636	235,000
2043	0	0	213,636	235,000
2044	0	0	213,636	235,000

Pollutant Parameters

Gas / Pollutant Default Parameters:				User-specified Pollutant Parameters:	
	Compound	Concentration (ppmv)	Molecular Weight	Concentration (ppmv)	Molecular Weight
Gases	Total landfill gas		0.00		
	Methane		16.04		
	Carbon dioxide		44.01		
	NMOC	4,000	86.18		
Pollutants	1,1,1-Trichloroethane (methyl chloroform) - HAP	0.48	133.41		
	1,1,1,2,2- Tetrachloroethane - HAP/VOC	1.1	167.85		
	1,1-Dichloroethane (ethylidene dichloride) - HAP/VOC	2.4	98.97		
	1,1-Dichloroethene (vinylidene chloride) - HAP/VOC	0.20	96.94		
	1,2-Dichloroethane (ethylene dichloride) - HAP/VOC	0.41	98.96		
	1,2-Dichloropropane (propylene dichloride) - HAP/VOC	0.18	112.99		
	2-Propanol (isopropyl alcohol) - VOC	50	60.11		
	Acetone	7.0	58.08		
	Acrylonitrile - HAP/VOC	6.3	53.06		
	Benzene - No or Unknown Co-disposal - HAP/VOC	1.9	78.11		
	Benzene - Co-disposal - HAP/VOC	11	78.11		
	Bromodichloromethane - VOC	3.1	163.83		
	Butane - VOC	5.0	58.12		
	Carbon disulfide - HAP/VOC	0.58	76.13		
	Carbon monoxide	140	28.01		
	Carbon tetrachloride - HAP/VOC	4.0E-03	153.84		
	Carbonyl sulfide - HAP/VOC	0.49	60.07		
	Chlorobenzene - HAP/VOC	0.25	112.56		
	Chlorodifluoromethane	1.3	86.47		
	Chloroethane (ethyl chloride) - HAP/VOC	1.3	64.52		
	Chloroform - HAP/VOC	0.03	119.39		
	Chloromethane - VOC	1.2	50.49		
	Dichlorobenzene - (HAP for para isomer/VOC)	0.21	147		
	Dichlorodifluoromethane	16	120.91		
	Dichlorofluoromethane - VOC	2.6	102.92		
	Dichloromethane (methylene chloride) - HAP	14	84.94		
	Dimethyl sulfide (methyl sulfide) - VOC	7.8	62.13		
	Ethane	890	30.07		
	Ethanol - VOC	27	46.08		

Pollutant Parameters (Continued)

Gas / Pollutant Default Parameters:			User-specified Pollutant Parameters:		
	Compound	Concentration (ppmv)	Molecular Weight	Concentration (ppmv)	Molecular Weight
Pollutants	Ethyl mercaptan (ethanethiol) - VOC	2.3	62.13		
	Ethylbenzene - HAP/VOC	4.6	106.16		
	Ethylene dibromide - HAP/VOC	1.0E-03	187.88		
	Fluorotrichloromethane - VOC	0.76	137.38		
	Hexane - HAP/VOC	6.6	86.18		
	Hydrogen sulfide	36	34.08		
	Mercury (total) - HAP	2.9E-04	200.61		
	Methyl ethyl ketone - HAP/VOC	7.1	72.11		
	Methyl isobutyl ketone - HAP/VOC	1.9	100.16		
	Methyl mercaptan - VOC	2.5	48.11		
	Pentane - VOC	3.3	72.15		
	Perchloroethylene (tetrachloroethylene) - HAP	3.7	165.83		
	Propane - VOC	11	44.09		
	t-1,2-Dichloroethene - VOC	2.8	96.94		
	Toluene - No or Unknown Co-disposal - HAP/VOC	39	92.13		
	Toluene - Co-disposal - HAP/VOC	170	92.13		
	Trichloroethylene (trichloroethene) - HAP/VOC	2.8	131.40		
	Vinyl chloride - HAP/VOC	7.3	62.50		
	Xylenes - HAP/VOC	12	106.16		

Graphs

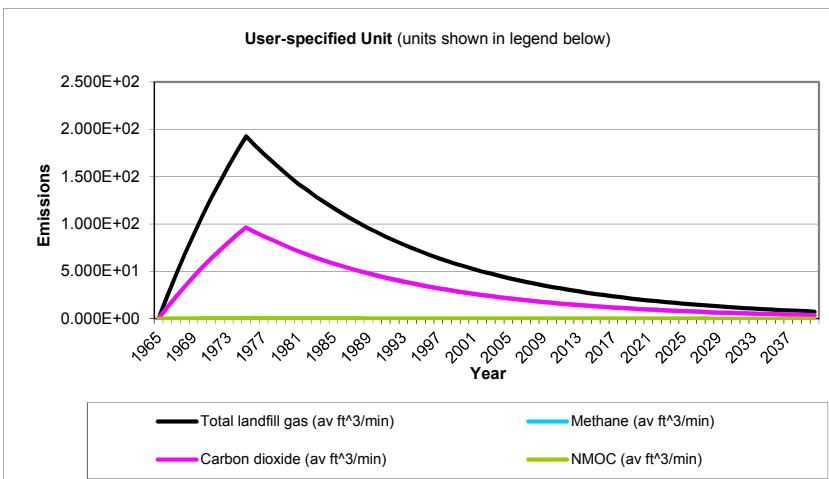
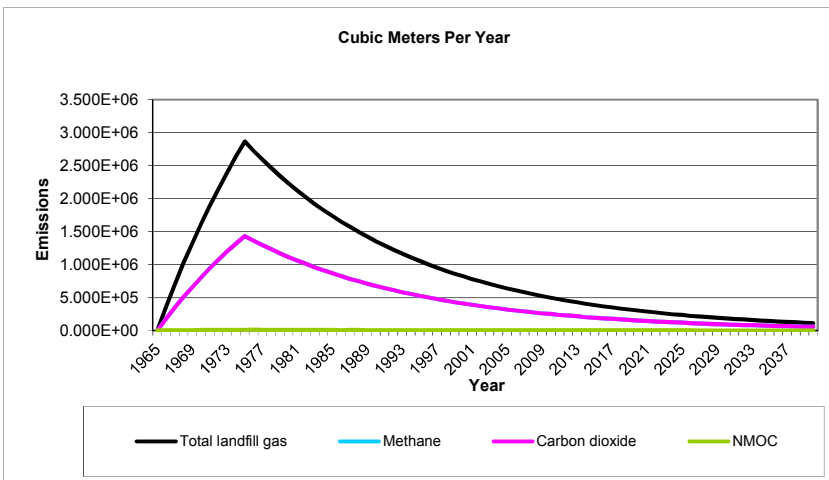
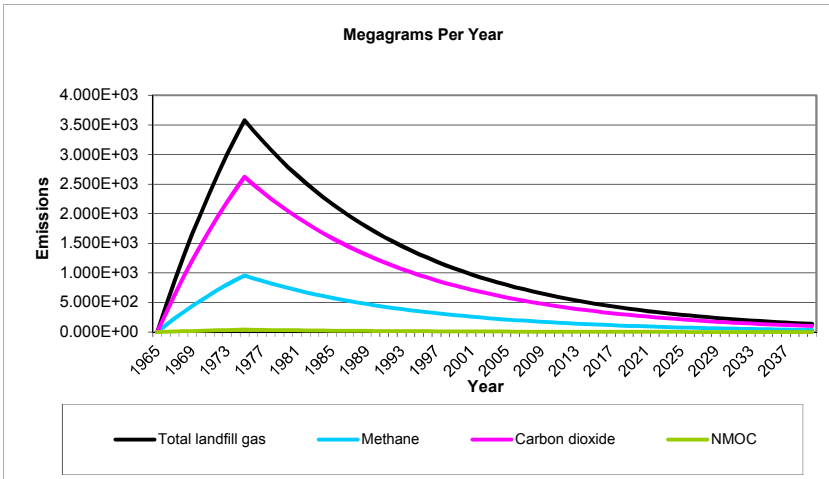

Results

Year	Total landfill gas			Methane		
	(Mg/year)	(m ³ /year)	(av ft ³ /min)	(Mg/year)	(m ³ /year)	(av ft ³ /min)
1965	0	0	0	0	0	0
1966	4.435E+02	3.551E+05	2.386E+01	1.185E+02	1.776E+05	1.193E+01
1967	8.654E+02	6.930E+05	4.656E+01	2.312E+02	3.465E+05	2.328E+01
1968	1.267E+03	1.014E+06	6.815E+01	3.383E+02	5.071E+05	3.408E+01
1969	1.648E+03	1.320E+06	8.869E+01	4.403E+02	6.600E+05	4.434E+01
1970	2.012E+03	1.611E+06	1.082E+02	5.373E+02	8.054E+05	5.411E+01
1971	2.357E+03	1.887E+06	1.268E+02	6.296E+02	9.437E+05	6.340E+01
1972	2.685E+03	2.150E+06	1.445E+02	7.173E+02	1.075E+06	7.224E+01
1973	2.998E+03	2.401E+06	1.613E+02	8.008E+02	1.200E+06	8.065E+01
1974	3.295E+03	2.639E+06	1.773E+02	8.802E+02	1.319E+06	8.865E+01
1975	3.578E+03	2.865E+06	1.925E+02	9.557E+02	1.433E+06	9.626E+01
1976	3.404E+03	2.725E+06	1.831E+02	9.091E+02	1.363E+06	9.156E+01
1977	3.238E+03	2.593E+06	1.742E+02	8.648E+02	1.296E+06	8.710E+01
1978	3.080E+03	2.466E+06	1.657E+02	8.226E+02	1.233E+06	8.285E+01
1979	2.929E+03	2.346E+06	1.576E+02	7.825E+02	1.173E+06	7.881E+01
1980	2.787E+03	2.231E+06	1.499E+02	7.443E+02	1.116E+06	7.496E+01
1981	2.651E+03	2.123E+06	1.426E+02	7.080E+02	1.061E+06	7.131E+01
1982	2.521E+03	2.019E+06	1.357E+02	6.735E+02	1.010E+06	6.783E+01
1983	2.398E+03	1.921E+06	1.290E+02	6.407E+02	9.603E+05	6.452E+01
1984	2.281E+03	1.827E+06	1.228E+02	6.094E+02	9.135E+05	6.138E+01
1985	2.170E+03	1.738E+06	1.168E+02	5.797E+02	8.689E+05	5.838E+01
1986	2.064E+03	1.653E+06	1.111E+02	5.514E+02	8.265E+05	5.553E+01
1987	1.964E+03	1.572E+06	1.057E+02	5.245E+02	7.862E+05	5.283E+01
1988	1.868E+03	1.496E+06	1.005E+02	4.989E+02	7.479E+05	5.025E+01
1989	1.777E+03	1.423E+06	9.560E+01	4.746E+02	7.114E+05	4.780E+01
1990	1.690E+03	1.353E+06	9.094E+01	4.515E+02	6.767E+05	4.547E+01
1991	1.608E+03	1.287E+06	8.650E+01	4.294E+02	6.437E+05	4.325E+01
1992	1.529E+03	1.225E+06	8.228E+01	4.085E+02	6.123E+05	4.114E+01
1993	1.455E+03	1.165E+06	7.827E+01	3.886E+02	5.824E+05	3.913E+01
1994	1.384E+03	1.108E+06	7.445E+01	3.696E+02	5.540E+05	3.723E+01
1995	1.316E+03	1.054E+06	7.082E+01	3.516E+02	5.270E+05	3.541E+01
1996	1.252E+03	1.003E+06	6.737E+01	3.345E+02	5.013E+05	3.368E+01
1997	1.191E+03	9.537E+05	6.408E+01	3.181E+02	4.769E+05	3.204E+01
1998	1.133E+03	9.072E+05	6.096E+01	3.026E+02	4.536E+05	3.048E+01
1999	1.078E+03	8.630E+05	5.798E+01	2.879E+02	4.315E+05	2.899E+01
2000	1.025E+03	8.209E+05	5.516E+01	2.738E+02	4.104E+05	2.758E+01
2001	9.751E+02	7.808E+05	5.247E+01	2.605E+02	3.904E+05	2.623E+01
2002	9.276E+02	7.428E+05	4.991E+01	2.478E+02	3.714E+05	2.495E+01
2003	8.823E+02	7.065E+05	4.747E+01	2.357E+02	3.533E+05	2.374E+01
2004	8.393E+02	6.721E+05	4.516E+01	2.242E+02	3.360E+05	2.258E+01
2005	7.984E+02	6.393E+05	4.295E+01	2.133E+02	3.197E+05	2.148E+01
2006	7.594E+02	6.081E+05	4.086E+01	2.029E+02	3.041E+05	2.043E+01
2007	7.224E+02	5.785E+05	3.887E+01	1.930E+02	2.892E+05	1.943E+01
2008	6.872E+02	5.503E+05	3.697E+01	1.836E+02	2.751E+05	1.849E+01
2009	6.537E+02	5.234E+05	3.517E+01	1.746E+02	2.617E+05	1.758E+01
2010	6.218E+02	4.979E+05	3.345E+01	1.661E+02	2.489E+05	1.673E+01
2011	5.915E+02	4.736E+05	3.182E+01	1.580E+02	2.368E+05	1.591E+01
2012	5.626E+02	4.505E+05	3.027E+01	1.503E+02	2.253E+05	1.513E+01
2013	5.352E+02	4.285E+05	2.879E+01	1.429E+02	2.143E+05	1.440E+01
2014	5.091E+02	4.076E+05	2.739E+01	1.360E+02	2.038E+05	1.369E+01

Results (Continued)

Year	Total landfill gas			Methane		
	(Mg/year)	(m ³ /year)	(av ft ³ /min)	(Mg/year)	(m ³ /year)	(av ft ³ /min)
2015	4.842E+02	3.878E+05	2.605E+01	1.293E+02	1.939E+05	1.303E+01
2016	4.606E+02	3.688E+05	2.478E+01	1.230E+02	1.844E+05	1.239E+01
2017	4.382E+02	3.509E+05	2.357E+01	1.170E+02	1.754E+05	1.179E+01
2018	4.168E+02	3.337E+05	2.242E+01	1.113E+02	1.669E+05	1.121E+01
2019	3.965E+02	3.175E+05	2.133E+01	1.059E+02	1.587E+05	1.067E+01
2020	3.771E+02	3.020E+05	2.029E+01	1.007E+02	1.510E+05	1.015E+01
2021	3.587E+02	2.873E+05	1.930E+01	9.582E+01	1.436E+05	9.650E+00
2022	3.412E+02	2.732E+05	1.836E+01	9.115E+01	1.366E+05	9.180E+00
2023	3.246E+02	2.599E+05	1.746E+01	8.670E+01	1.300E+05	8.732E+00
2024	3.088E+02	2.472E+05	1.661E+01	8.247E+01	1.236E+05	8.306E+00
2025	2.937E+02	2.352E+05	1.580E+01	7.845E+01	1.176E+05	7.901E+00
2026	2.794E+02	2.237E+05	1.503E+01	7.463E+01	1.119E+05	7.516E+00
2027	2.658E+02	2.128E+05	1.430E+01	7.099E+01	1.064E+05	7.149E+00
2028	2.528E+02	2.024E+05	1.360E+01	6.752E+01	1.012E+05	6.801E+00
2029	2.405E+02	1.926E+05	1.294E+01	6.423E+01	9.628E+04	6.469E+00
2030	2.287E+02	1.832E+05	1.231E+01	6.110E+01	9.158E+04	6.153E+00
2031	2.176E+02	1.742E+05	1.171E+01	5.812E+01	8.712E+04	5.853E+00
2032	2.070E+02	1.657E+05	1.114E+01	5.528E+01	8.287E+04	5.568E+00
2033	1.969E+02	1.577E+05	1.059E+01	5.259E+01	7.883E+04	5.296E+00
2034	1.873E+02	1.500E+05	1.008E+01	5.002E+01	7.498E+04	5.038E+00
2035	1.781E+02	1.426E+05	9.585E+00	4.758E+01	7.132E+04	4.792E+00
2036	1.695E+02	1.357E+05	9.117E+00	4.526E+01	6.785E+04	4.559E+00
2037	1.612E+02	1.291E+05	8.672E+00	4.306E+01	6.454E+04	4.336E+00
2038	1.533E+02	1.228E+05	8.249E+00	4.096E+01	6.139E+04	4.125E+00
2039	1.459E+02	1.168E+05	7.847E+00	3.896E+01	5.840E+04	3.924E+00
2040	1.387E+02	1.111E+05	7.464E+00	3.706E+01	5.555E+04	3.732E+00
2041	1.320E+02	1.057E+05	7.100E+00	3.525E+01	5.284E+04	3.550E+00
2042	1.255E+02	1.005E+05	6.754E+00	3.353E+01	5.026E+04	3.377E+00
2043	1.194E+02	9.562E+04	6.425E+00	3.190E+01	4.781E+04	3.212E+00
2044	1.136E+02	9.096E+04	6.111E+00	3.034E+01	4.548E+04	3.056E+00
2045	1.080E+02	8.652E+04	5.813E+00	2.886E+01	4.326E+04	2.907E+00
2046	1.028E+02	8.230E+04	5.530E+00	2.745E+01	4.115E+04	2.765E+00
2047	9.777E+01	7.829E+04	5.260E+00	2.611E+01	3.914E+04	2.630E+00
2048	9.300E+01	7.447E+04	5.004E+00	2.484E+01	3.723E+04	2.502E+00
2049	8.846E+01	7.084E+04	4.760E+00	2.363E+01	3.542E+04	2.380E+00
2050	8.415E+01	6.738E+04	4.527E+00	2.248E+01	3.369E+04	2.264E+00
2051	8.004E+01	6.410E+04	4.307E+00	2.138E+01	3.205E+04	2.153E+00
2052	7.614E+01	6.097E+04	4.097E+00	2.034E+01	3.049E+04	2.048E+00
2053	7.243E+01	5.800E+04	3.897E+00	1.935E+01	2.900E+04	1.948E+00
2054	6.890E+01	5.517E+04	3.707E+00	1.840E+01	2.758E+04	1.853E+00
2055	6.554E+01	5.248E+04	3.526E+00	1.751E+01	2.624E+04	1.763E+00
2056	6.234E+01	4.992E+04	3.354E+00	1.665E+01	2.496E+04	1.677E+00
2057	5.930E+01	4.748E+04	3.190E+00	1.584E+01	2.374E+04	1.595E+00
2058	5.641E+01	4.517E+04	3.035E+00	1.507E+01	2.258E+04	1.517E+00
2059	5.366E+01	4.296E+04	2.887E+00	1.433E+01	2.148E+04	1.443E+00
2060	5.104E+01	4.087E+04	2.746E+00	1.363E+01	2.043E+04	1.373E+00
2061	4.855E+01	3.888E+04	2.612E+00	1.297E+01	1.944E+04	1.306E+00
2062	4.618E+01	3.698E+04	2.485E+00	1.234E+01	1.849E+04	1.242E+00
2063	4.393E+01	3.518E+04	2.364E+00	1.173E+01	1.759E+04	1.182E+00
2064	4.179E+01	3.346E+04	2.248E+00	1.116E+01	1.673E+04	1.124E+00
2065	3.975E+01	3.183E+04	2.139E+00	1.062E+01	1.591E+04	1.069E+00

Results (Continued)

Year	Total landfill gas			Methane		
	(Mg/year)	(m ³ /year)	(av ft ³ /min)	(Mg/year)	(m ³ /year)	(av ft ³ /min)
2066	3.781E+01	3.028E+04	2.034E+00	1.010E+01	1.514E+04	1.017E+00
2067	3.597E+01	2.880E+04	1.935E+00	9.607E+00	1.440E+04	9.675E-01
2068	3.421E+01	2.740E+04	1.841E+00	9.138E+00	1.370E+04	9.204E-01
2069	3.254E+01	2.606E+04	1.751E+00	8.693E+00	1.303E+04	8.755E-01
2070	3.096E+01	2.479E+04	1.666E+00	8.269E+00	1.239E+04	8.328E-01
2071	2.945E+01	2.358E+04	1.584E+00	7.866E+00	1.179E+04	7.922E-01
2072	2.801E+01	2.243E+04	1.507E+00	7.482E+00	1.121E+04	7.535E-01
2073	2.664E+01	2.134E+04	1.434E+00	7.117E+00	1.067E+04	7.168E-01
2074	2.535E+01	2.030E+04	1.364E+00	6.770E+00	1.015E+04	6.818E-01
2075	2.411E+01	1.931E+04	1.297E+00	6.440E+00	9.653E+03	6.486E-01
2076	2.293E+01	1.836E+04	1.234E+00	6.126E+00	9.182E+03	6.169E-01
2077	2.181E+01	1.747E+04	1.174E+00	5.827E+00	8.734E+03	5.868E-01
2078	2.075E+01	1.662E+04	1.116E+00	5.543E+00	8.308E+03	5.582E-01
2079	1.974E+01	1.581E+04	1.062E+00	5.272E+00	7.903E+03	5.310E-01
2080	1.878E+01	1.504E+04	1.010E+00	5.015E+00	7.518E+03	5.051E-01
2081	1.786E+01	1.430E+04	9.609E-01	4.771E+00	7.151E+03	4.805E-01
2082	1.699E+01	1.360E+04	9.141E-01	4.538E+00	6.802E+03	4.570E-01
2083	1.616E+01	1.294E+04	8.695E-01	4.317E+00	6.470E+03	4.347E-01
2084	1.537E+01	1.231E+04	8.271E-01	4.106E+00	6.155E+03	4.135E-01
2085	1.462E+01	1.171E+04	7.867E-01	3.906E+00	5.855E+03	3.934E-01
2086	1.391E+01	1.114E+04	7.484E-01	3.715E+00	5.569E+03	3.742E-01
2087	1.323E+01	1.060E+04	7.119E-01	3.534E+00	5.298E+03	3.559E-01
2088	1.259E+01	1.008E+04	6.772E-01	3.362E+00	5.039E+03	3.386E-01
2089	1.197E+01	9.587E+03	6.441E-01	3.198E+00	4.793E+03	3.221E-01
2090	1.139E+01	9.119E+03	6.127E-01	3.042E+00	4.560E+03	3.064E-01
2091	1.083E+01	8.674E+03	5.828E-01	2.894E+00	4.337E+03	2.914E-01
2092	1.030E+01	8.251E+03	5.544E-01	2.752E+00	4.126E+03	2.772E-01
2093	9.802E+00	7.849E+03	5.274E-01	2.618E+00	3.924E+03	2.637E-01
2094	9.324E+00	7.466E+03	5.017E-01	2.491E+00	3.733E+03	2.508E-01
2095	8.869E+00	7.102E+03	4.772E-01	2.369E+00	3.551E+03	2.386E-01
2096	8.437E+00	6.756E+03	4.539E-01	2.254E+00	3.378E+03	2.270E-01
2097	8.025E+00	6.426E+03	4.318E-01	2.144E+00	3.213E+03	2.159E-01
2098	7.634E+00	6.113E+03	4.107E-01	2.039E+00	3.056E+03	2.054E-01
2099	7.261E+00	5.815E+03	3.907E-01	1.940E+00	2.907E+03	1.953E-01
2100	6.907E+00	5.531E+03	3.716E-01	1.845E+00	2.766E+03	1.858E-01
2101	6.570E+00	5.261E+03	3.535E-01	1.755E+00	2.631E+03	1.768E-01
2102	6.250E+00	5.005E+03	3.363E-01	1.669E+00	2.502E+03	1.681E-01
2103	5.945E+00	4.761E+03	3.199E-01	1.588E+00	2.380E+03	1.599E-01
2104	5.655E+00	4.528E+03	3.043E-01	1.511E+00	2.264E+03	1.521E-01
2105	5.379E+00	4.308E+03	2.894E-01	1.437E+00	2.154E+03	1.447E-01

Results (Continued)

Year	Carbon dioxide			NMOC		
	(Mg/year)	(m ³ /year)	(av ft ³ /min)	(Mg/year)	(m ³ /year)	(av ft ³ /min)
1965	0	0	0	0	0	0
1966	3.250E+02	1.776E+05	1.193E+01	5.092E+00	1.421E+03	9.545E-02
1967	6.342E+02	3.465E+05	2.328E+01	9.936E+00	2.772E+03	1.862E-01
1968	9.283E+02	5.071E+05	3.408E+01	1.454E+01	4.057E+03	2.726E-01
1969	1.208E+03	6.600E+05	4.434E+01	1.893E+01	5.280E+03	3.548E-01
1970	1.474E+03	8.054E+05	5.411E+01	2.309E+01	6.443E+03	4.329E-01
1971	1.727E+03	9.437E+05	6.340E+01	2.706E+01	7.549E+03	5.072E-01
1972	1.968E+03	1.075E+06	7.224E+01	3.083E+01	8.602E+03	5.779E-01
1973	2.197E+03	1.200E+06	8.065E+01	3.442E+01	9.603E+03	6.452E-01
1974	2.415E+03	1.319E+06	8.865E+01	3.783E+01	1.055E+04	7.092E-01
1975	2.622E+03	1.433E+06	9.626E+01	4.108E+01	1.146E+04	7.700E-01
1976	2.494E+03	1.363E+06	9.156E+01	3.908E+01	1.090E+04	7.325E-01
1977	2.373E+03	1.296E+06	8.710E+01	3.717E+01	1.037E+04	6.968E-01
1978	2.257E+03	1.233E+06	8.285E+01	3.536E+01	9.864E+03	6.628E-01
1979	2.147E+03	1.173E+06	7.881E+01	3.363E+01	9.383E+03	6.305E-01
1980	2.042E+03	1.116E+06	7.496E+01	3.199E+01	8.926E+03	5.997E-01
1981	1.943E+03	1.061E+06	7.131E+01	3.043E+01	8.490E+03	5.705E-01
1982	1.848E+03	1.010E+06	6.783E+01	2.895E+01	8.076E+03	5.426E-01
1983	1.758E+03	9.603E+05	6.452E+01	2.754E+01	7.682E+03	5.162E-01
1984	1.672E+03	9.135E+05	6.138E+01	2.619E+01	7.308E+03	4.910E-01
1985	1.591E+03	8.689E+05	5.838E+01	2.492E+01	6.951E+03	4.671E-01
1986	1.513E+03	8.265E+05	5.553E+01	2.370E+01	6.612E+03	4.443E-01
1987	1.439E+03	7.862E+05	5.283E+01	2.255E+01	6.290E+03	4.226E-01
1988	1.369E+03	7.479E+05	5.025E+01	2.145E+01	5.983E+03	4.020E-01
1989	1.302E+03	7.114E+05	4.780E+01	2.040E+01	5.691E+03	3.824E-01
1990	1.239E+03	6.767E+05	4.547E+01	1.941E+01	5.414E+03	3.637E-01
1991	1.178E+03	6.437E+05	4.325E+01	1.846E+01	5.150E+03	3.460E-01
1992	1.121E+03	6.123E+05	4.114E+01	1.756E+01	4.898E+03	3.291E-01
1993	1.066E+03	5.824E+05	3.913E+01	1.670E+01	4.660E+03	3.131E-01
1994	1.014E+03	5.540E+05	3.723E+01	1.589E+01	4.432E+03	2.978E-01
1995	9.647E+02	5.270E+05	3.541E+01	1.511E+01	4.216E+03	2.833E-01
1996	9.177E+02	5.013E+05	3.368E+01	1.438E+01	4.011E+03	2.695E-01
1997	8.729E+02	4.769E+05	3.204E+01	1.367E+01	3.815E+03	2.563E-01
1998	8.303E+02	4.536E+05	3.048E+01	1.301E+01	3.629E+03	2.438E-01
1999	7.898E+02	4.315E+05	2.899E+01	1.237E+01	3.452E+03	2.319E-01
2000	7.513E+02	4.104E+05	2.758E+01	1.177E+01	3.284E+03	2.206E-01
2001	7.147E+02	3.904E+05	2.623E+01	1.120E+01	3.123E+03	2.099E-01
2002	6.798E+02	3.714E+05	2.495E+01	1.065E+01	2.971E+03	1.996E-01
2003	6.467E+02	3.533E+05	2.374E+01	1.013E+01	2.826E+03	1.899E-01
2004	6.151E+02	3.360E+05	2.258E+01	9.636E+00	2.688E+03	1.806E-01
2005	5.851E+02	3.197E+05	2.148E+01	9.166E+00	2.557E+03	1.718E-01
2006	5.566E+02	3.041E+05	2.043E+01	8.719E+00	2.433E+03	1.634E-01
2007	5.294E+02	2.892E+05	1.943E+01	8.294E+00	2.314E+03	1.555E-01
2008	5.036E+02	2.751E+05	1.849E+01	7.889E+00	2.201E+03	1.479E-01
2009	4.791E+02	2.617E+05	1.758E+01	7.505E+00	2.094E+03	1.407E-01
2010	4.557E+02	2.489E+05	1.673E+01	7.139E+00	1.992E+03	1.338E-01
2011	4.335E+02	2.368E+05	1.591E+01	6.791E+00	1.894E+03	1.273E-01
2012	4.123E+02	2.253E+05	1.513E+01	6.459E+00	1.802E+03	1.211E-01
2013	3.922E+02	2.143E+05	1.440E+01	6.144E+00	1.714E+03	1.152E-01
2014	3.731E+02	2.038E+05	1.369E+01	5.845E+00	1.631E+03	1.096E-01

Results (Continued)

Year	Carbon dioxide			NMOC		
	(Mg/year)	(m ³ /year)	(av ft ³ /min)	(Mg/year)	(m ³ /year)	(av ft ³ /min)
2015	3.549E+02	1.939E+05	1.303E+01	5.560E+00	1.551E+03	1.042E-01
2016	3.376E+02	1.844E+05	1.239E+01	5.288E+00	1.475E+03	9.913E-02
2017	3.211E+02	1.754E+05	1.179E+01	5.031E+00	1.403E+03	9.430E-02
2018	3.055E+02	1.669E+05	1.121E+01	4.785E+00	1.335E+03	8.970E-02
2019	2.906E+02	1.587E+05	1.067E+01	4.552E+00	1.270E+03	8.532E-02
2020	2.764E+02	1.510E+05	1.015E+01	4.330E+00	1.208E+03	8.116E-02
2021	2.629E+02	1.436E+05	9.650E+00	4.119E+00	1.149E+03	7.720E-02
2022	2.501E+02	1.366E+05	9.180E+00	3.918E+00	1.093E+03	7.344E-02
2023	2.379E+02	1.300E+05	8.732E+00	3.727E+00	1.040E+03	6.986E-02
2024	2.263E+02	1.236E+05	8.306E+00	3.545E+00	9.890E+02	6.645E-02
2025	2.153E+02	1.176E+05	7.901E+00	3.372E+00	9.407E+02	6.321E-02
2026	2.048E+02	1.119E+05	7.516E+00	3.208E+00	8.949E+02	6.013E-02
2027	1.948E+02	1.064E+05	7.149E+00	3.051E+00	8.512E+02	5.719E-02
2028	1.853E+02	1.012E+05	6.801E+00	2.902E+00	8.097E+02	5.440E-02
2029	1.762E+02	9.628E+04	6.469E+00	2.761E+00	7.702E+02	5.175E-02
2030	1.676E+02	9.158E+04	6.153E+00	2.626E+00	7.327E+02	4.923E-02
2031	1.595E+02	8.712E+04	5.853E+00	2.498E+00	6.969E+02	4.683E-02
2032	1.517E+02	8.287E+04	5.568E+00	2.376E+00	6.629E+02	4.454E-02
2033	1.443E+02	7.883E+04	5.296E+00	2.260E+00	6.306E+02	4.237E-02
2034	1.373E+02	7.498E+04	5.038E+00	2.150E+00	5.998E+02	4.030E-02
2035	1.306E+02	7.132E+04	4.792E+00	2.045E+00	5.706E+02	3.834E-02
2036	1.242E+02	6.785E+04	4.559E+00	1.946E+00	5.428E+02	3.647E-02
2037	1.181E+02	6.454E+04	4.336E+00	1.851E+00	5.163E+02	3.469E-02
2038	1.124E+02	6.139E+04	4.125E+00	1.760E+00	4.911E+02	3.300E-02
2039	1.069E+02	5.840E+04	3.924E+00	1.675E+00	4.672E+02	3.139E-02
2040	1.017E+02	5.555E+04	3.732E+00	1.593E+00	4.444E+02	2.986E-02
2041	9.672E+01	5.284E+04	3.550E+00	1.515E+00	4.227E+02	2.840E-02
2042	9.200E+01	5.026E+04	3.377E+00	1.441E+00	4.021E+02	2.702E-02
2043	8.752E+01	4.781E+04	3.212E+00	1.371E+00	3.825E+02	2.570E-02
2044	8.325E+01	4.548E+04	3.056E+00	1.304E+00	3.638E+02	2.445E-02
2045	7.919E+01	4.326E+04	2.907E+00	1.241E+00	3.461E+02	2.325E-02
2046	7.533E+01	4.115E+04	2.765E+00	1.180E+00	3.292E+02	2.212E-02
2047	7.165E+01	3.914E+04	2.630E+00	1.122E+00	3.131E+02	2.104E-02
2048	6.816E+01	3.723E+04	2.502E+00	1.068E+00	2.979E+02	2.001E-02
2049	6.483E+01	3.542E+04	2.380E+00	1.016E+00	2.833E+02	1.904E-02
2050	6.167E+01	3.369E+04	2.264E+00	9.661E-01	2.695E+02	1.811E-02
2051	5.866E+01	3.205E+04	2.153E+00	9.190E-01	2.564E+02	1.723E-02
2052	5.580E+01	3.049E+04	2.048E+00	8.742E-01	2.439E+02	1.639E-02
2053	5.308E+01	2.900E+04	1.948E+00	8.315E-01	2.320E+02	1.559E-02
2054	5.049E+01	2.758E+04	1.853E+00	7.910E-01	2.207E+02	1.483E-02
2055	4.803E+01	2.624E+04	1.763E+00	7.524E-01	2.099E+02	1.410E-02
2056	4.569E+01	2.496E+04	1.677E+00	7.157E-01	1.997E+02	1.342E-02
2057	4.346E+01	2.374E+04	1.595E+00	6.808E-01	1.899E+02	1.276E-02
2058	4.134E+01	2.258E+04	1.517E+00	6.476E-01	1.807E+02	1.214E-02
2059	3.932E+01	2.148E+04	1.443E+00	6.160E-01	1.719E+02	1.155E-02
2060	3.741E+01	2.043E+04	1.373E+00	5.860E-01	1.635E+02	1.098E-02
2061	3.558E+01	1.944E+04	1.306E+00	5.574E-01	1.555E+02	1.045E-02
2062	3.385E+01	1.849E+04	1.242E+00	5.302E-01	1.479E+02	9.939E-03
2063	3.220E+01	1.759E+04	1.182E+00	5.044E-01	1.407E+02	9.454E-03
2064	3.063E+01	1.673E+04	1.124E+00	4.798E-01	1.338E+02	8.993E-03
2065	2.913E+01	1.591E+04	1.069E+00	4.564E-01	1.273E+02	8.554E-03

Results (Continued)

Year	Carbon dioxide			NMOC		
	(Mg/year)	(m ³ /year)	(av ft ³ /min)	(Mg/year)	(m ³ /year)	(av ft ³ /min)
2066	2.771E+01	1.514E+04	1.017E+00	4.341E-01	1.211E+02	8.137E-03
2067	2.636E+01	1.440E+04	9.675E-01	4.129E-01	1.152E+02	7.740E-03
2068	2.507E+01	1.370E+04	9.204E-01	3.928E-01	1.096E+02	7.363E-03
2069	2.385E+01	1.303E+04	8.755E-01	3.736E-01	1.042E+02	7.004E-03
2070	2.269E+01	1.239E+04	8.328E-01	3.554E-01	9.915E+01	6.662E-03
2071	2.158E+01	1.179E+04	7.922E-01	3.381E-01	9.432E+01	6.337E-03
2072	2.053E+01	1.121E+04	7.535E-01	3.216E-01	8.972E+01	6.028E-03
2073	1.953E+01	1.067E+04	7.168E-01	3.059E-01	8.534E+01	5.734E-03
2074	1.858E+01	1.015E+04	6.818E-01	2.910E-01	8.118E+01	5.455E-03
2075	1.767E+01	9.653E+03	6.486E-01	2.768E-01	7.722E+01	5.188E-03
2076	1.681E+01	9.182E+03	6.169E-01	2.633E-01	7.346E+01	4.935E-03
2077	1.599E+01	8.734E+03	5.868E-01	2.505E-01	6.987E+01	4.695E-03
2078	1.521E+01	8.308E+03	5.582E-01	2.382E-01	6.647E+01	4.466E-03
2079	1.447E+01	7.903E+03	5.310E-01	2.266E-01	6.322E+01	4.248E-03
2080	1.376E+01	7.518E+03	5.051E-01	2.156E-01	6.014E+01	4.041E-03
2081	1.309E+01	7.151E+03	4.805E-01	2.051E-01	5.721E+01	3.844E-03
2082	1.245E+01	6.802E+03	4.570E-01	1.951E-01	5.442E+01	3.656E-03
2083	1.184E+01	6.470E+03	4.347E-01	1.855E-01	5.176E+01	3.478E-03
2084	1.127E+01	6.155E+03	4.135E-01	1.765E-01	4.924E+01	3.308E-03
2085	1.072E+01	5.855E+03	3.934E-01	1.679E-01	4.684E+01	3.147E-03
2086	1.019E+01	5.569E+03	3.742E-01	1.597E-01	4.455E+01	2.994E-03
2087	9.697E+00	5.298E+03	3.559E-01	1.519E-01	4.238E+01	2.848E-03
2088	9.224E+00	5.039E+03	3.386E-01	1.445E-01	4.031E+01	2.709E-03
2089	8.774E+00	4.793E+03	3.221E-01	1.375E-01	3.835E+01	2.577E-03
2090	8.346E+00	4.560E+03	3.064E-01	1.307E-01	3.648E+01	2.451E-03
2091	7.939E+00	4.337E+03	2.914E-01	1.244E-01	3.470E+01	2.331E-03
2092	7.552E+00	4.126E+03	2.772E-01	1.183E-01	3.301E+01	2.218E-03
2093	7.184E+00	3.924E+03	2.637E-01	1.125E-01	3.140E+01	2.109E-03
2094	6.833E+00	3.733E+03	2.508E-01	1.070E-01	2.986E+01	2.007E-03
2095	6.500E+00	3.551E+03	2.386E-01	1.018E-01	2.841E+01	1.909E-03
2096	6.183E+00	3.378E+03	2.270E-01	9.686E-02	2.702E+01	1.816E-03
2097	5.882E+00	3.213E+03	2.159E-01	9.214E-02	2.570E+01	1.727E-03
2098	5.595E+00	3.056E+03	2.054E-01	8.764E-02	2.445E+01	1.643E-03
2099	5.322E+00	2.907E+03	1.953E-01	8.337E-02	2.326E+01	1.563E-03
2100	5.062E+00	2.766E+03	1.858E-01	7.930E-02	2.212E+01	1.487E-03
2101	4.815E+00	2.631E+03	1.768E-01	7.544E-02	2.105E+01	1.414E-03
2102	4.581E+00	2.502E+03	1.681E-01	7.176E-02	2.002E+01	1.345E-03
2103	4.357E+00	2.380E+03	1.599E-01	6.826E-02	1.904E+01	1.279E-03
2104	4.145E+00	2.264E+03	1.521E-01	6.493E-02	1.811E+01	1.217E-03
2105	3.943E+00	2.154E+03	1.447E-01	6.176E-02	1.723E+01	1.158E-03

Landfill Gas Control System Product Details



Geo-Net and Geocomposite Drains

1. Product Description

Geo-Net, also called drainage net, is a cost effective alternative to aggregate drains in containment systems. Geo-Nets take up less space than aggregate drains and can help to maximize volume in landfills and surface impoundments. Geo-Nets are commonly used between two geomembrane liners as part of a leak detection system. When placing Geo-Nets with geotextiles it is often effective to have the geotextile bonded to the Geo-Net in the factory. Geocomposites usually have a geotextile bonded to one, or to both sides of a Geo-Net. This creates a drainage structure that can be used between layers of geomembranes, and in many other unusual situations. The geotextile layers prevent the movement of soil fines into the Geo-Net drainage path that could lead to clogging and drainage failure.

2. Technical Data

Materials information is on page 2.

3. Installation

The light-weight of Geo-Net makes it easy to install in all applications, including steep slopes where the placement of aggregate drains would be impractical. Geo-Nets are normally supplied to the field as roll goods of standard size. Each roll is deployed in place and overlapped about 100 mm (4 inches). This



4. Availability and Cost

Available from Layfield or distributors. Call
425-254-1075 Pacific time
780-453-6731 Mountain time, or
905-761-9123 Eastern time

5. Manufactured For

Layfield USA Corp.
Layfield Canada Ltd.

6. Warranty

Products sold will meet Layfield's published specifications at time of sale. Full warranty details are available from Layfield.

7. Maintenance

Once geotextiles and geogrids are installed and carefully backfilled they do not require ongoing maintenance.

overlap is tied in place with plastic ties at a rate of one tie every 1.5 m (5 ft). Ties should be a contrasting colour to the black Geo-Net (white nylon ties are most common). Geo-Net is not designed for reinforcement or support. The plastic ties hold the Geo-Net in place and are not intended to provide significant seam strength.

8. Filing Systems

<https://www.layfieldgroup.com/Geosynthetics/Drainage-Products/Geo-Net-and-Geocomposite-Drains.aspx>

9.

8 November 2010	Geo-Net Material Properties		
Style	ASTM	Geo-Net 5	Geo-Net 6
Thickness(Nominal)	D5199	220 +/- 20 mil 5.5 +/- 0.5 mm	270 +/- 15 mil 6.8 +/- 0.4 mm
Tensile Strength	D5035	50 lb/in 87.8 N/cm	75 lb/in 131.7 N/cm
Transmissivity ¹	D4716	1x10 ⁻³ m ² /sec	3x10 ⁻³ m ² /sec
Carbon Black Content	D1603	2%	2 %

10.

8 November 2010	Geo-Composite Material Properties (MARV)		
Style	ASTM	Geo-Comp 5-2-6	Geo-Comp 5-2-8
Geo-Net Component			
Thickness(Nominal)	D5199	220 +/- 20 mil 5.5 +/-0.5 mm	220 +/- 20 mil 5.5 +/- 0.5 mm
Tensile Strength	D5035	50 lb/in 87.8 N/cm	50 lb/in 87.8 N/cm
Transmissivity (Geocomp) ¹	D4716	1 x 10 ⁻⁴ m ² /sec	1 x 10 ⁻⁴ m ² /sec
Carbon Black Content	D1603	2%	2%
Geotextile Component (component properties are tested prior to lamination process)			
Grab Tensile	D4632	160 lbs 712 N	225 lbs 1001 N
Puncture Resistance	D4833	80 lbs 356 N	130 lbs 578 N
Water Flow Rate	D4491	125 gpm/ft ² 5078 l/min/m ²	100 gpm/ft ² 4063 l/min/m ²
AOS (Sieve Size)	D4751	70 sieve 0.210 mm	80 sieve 0.180 mm

Fabric Weight (Nominal)	D5261	6 oz/yd ² 203 g/m ²	8 oz/yd ² 271 g/m ²
-------------------------	-------	--	--

¹Transmissivity measured using water at 21 ± 2°C (70 ± 4°F) with a gradient of 0.1 and a confining pressure of 10000 psf between steel plates after 15 minutes. Values may vary between individual labs.

² Above configuration is Geo-net laminated on both sides to geotextile layers. Geocomposite is also available with geotextile on only one side of Geo-net (eg. 5-1-6 or 5-1-8) or Geo-net 6 as the Geo-Net.



www.LayfieldConstructionProducts.com
customerservice@layfieldgroup.com

SITEDRAIN™ STRIP 9000 SERIES

PREFABRICATED STRIP DRAINS

americanwick.com



PRODUCT OVERVIEW

SITEDRAIN Strip 9000 Series prefabricated soil drains are constructed by fully wrapping a perforated, high strength, high flow capacity polystyrene core with a nonwoven filter fabric. The filter fabric is bonded to the core and prevents soil intrusion into the flow channels while allowing water to freely enter the drain core from all sides.

SITEDRAIN Strip 9000 is designed as a cost-effective, sustainable, performance driven alternative to perforated pipe & stone systems. SITEDRAIN Strip 9000 is available with filter fabrics meeting AASHTO M 288-06 specifications.

Typical Property Values	ASTM Test Method	Unit of Measure	9000	9400	9600	9800	9400-T
FABRIC							
Material ¹			PP	PP	PP	PP	PP
Water Flow Rate	D-4491	gpm/ft ²	150	150	110	90	80
		Lpm/m ²	6,113	6,113	4,483	3,668	3,260
Grab Tensile Strength	D-4632	lbs	115	130	160	205	145
		N	512	578	712	912	645
Puncture Resistance	D-4833	lbs	70	75	90	120	50
		N	311	334	400	534	222
Apparent Opening Size	D-4751	sieve	70	70	70	80	80
		mm	0.210	0.210	0.210	0.177	0.177
Permittivity	D-4491	sec ⁻¹	2.2	2.1	1.8	1.3	1.0
Grab Elongation	D-4632	%	70	70	70	70	60
UV Resistance	D-4355	% / 500 Hrs	70	70	70	70	70
AASHTO M 288-06 ²	Survivability	-	-	Class 3	Class 2	Class 1	Class 3
CORE							
Material ¹			HIPS	HIPS	HIPS	HIPS	HIPS
Thickness	D-1777	in	1.0	1.0	1.0	1.0	1.0
		mm	25.4	25.4	25.4	25.4	25.4
Compressive Strength	D-1621	psf	9,000	9,000	9,000	9,000	9,000
		kPa	431	431	431	431	431
Flow Rate ³	D-4716	gpm/ft	21	21	21	21	21
		Lpm/m	261	261	261	261	261

1 - PP = Polypropylene; HIPS = High Impact Polystyrene

2 - AASHTO Designation: M 288-06 Standard Specification for Highway Applications; American Association of State Highway and Transportation Officials, 2006. Geotextile survivability classification from installation stresses in subsurface drainage applications.

3 - In-plane flow rate measured at 3,600 psf (172 kPa) compressive load and a hydraulic gradient of 0.1.



AWD
AMERICAN WICK DRAIN

1209 Airport Road, Monroe, NC 28110
 TF 800.242.WICK • PH 704.238.9200
 FX 704.238.0220 • info@americanwick.com



RECYCLED
CONTENT



STEGO® WRAP VAPOR BARRIER

ASTM E 1745 Class A-B-C Compliant

STEGO® WRAP VAPOR BARRIER

is made with our proven trade secret blend of prime virgin resins and additives. Stego Wrap Vapor Barrier is an ASTM E 1745 Class A Vapor Barrier (Below 0.01 perms). We focus on producing a product that will maintain its extremely low permeance for the life of a building. The protection of Stego Wrap Vapor Barrier provides the flexibility to change flooring types and overall building use without worrying about below-slab moisture vapor.

FEATURES & BENEFITS

Unsurpassed Permeance Characteristics

Life of the Building Protection

Exceptional Tear and Puncture Resistance

Easy, Reliable Installation

Competitively Priced

Available Nationwide

Local Support

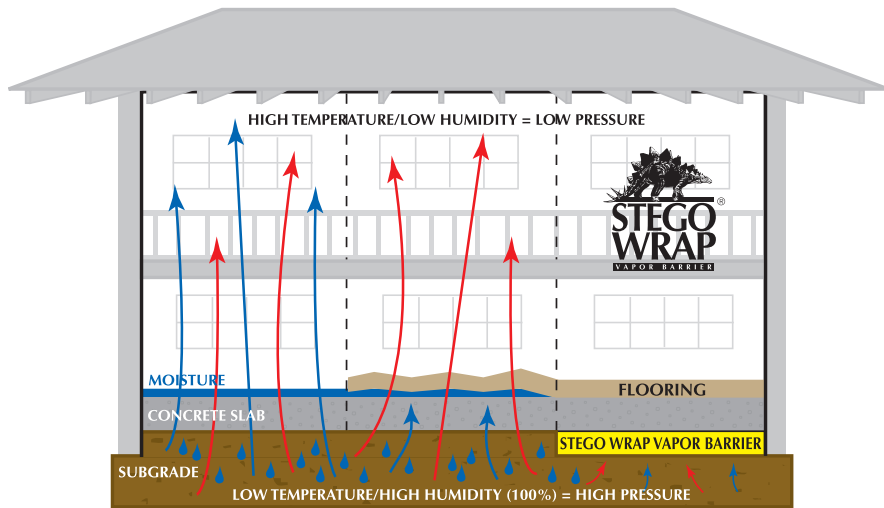

Regardless of the location of the water table, humidity below concrete slabs approximates 100%. Typical below slab vapor pressure is more than twice that of building interiors at room temperature, creating vapor drive from the substrate, up through the slab, and into the building.

THE STEGO® ADVANTAGES

SUPERIOR DEFENSE Against Floor Failures:

Experts say "the need for a vapor barrier (as opposed to a vapor retarder) is becoming increasingly clear." Concrete Construction Magazine, August 2003, p.18.

Infiltration of moisture through concrete slabs is a major building defect liability. Stego Wrap Vapor Barrier has an extremely low permeance preventing water vapor, soil gases (i.e. Radon), alkaline salts and soil sulfates from compromising the integrity of the building envelope and leading to serious problems with the concrete slab, floor coverings and indoor air quality. Stego Wrap Vapor Barrier is the best protection against these costly failures.

MOLD PREVENTION:

Mold needs three things to survive: moisture, sustained temperature (between 50° and 122° F), and a food source (dust, drywall, etc.). In any given building environment, contractors can only control one of these variables: moisture. Mold spores are present in 100% of building interiors. If moisture is allowed into your building environment, mold can and will grow. Toxic molds like *Stachybotrys* can be fatal for nearly 5% of people (Institute of Medicine 1993), and cause a variety of serious health problems in others. Several recent well-publicized cases involving toxic mold have resulted in multimillion-dollar insurance settlements. Many of the nation's leading Insurance companies have severely limited or removed coverage for mold claims fearing that these claims will bankrupt their companies. Now more than ever, it is critically important that extra attention be paid to preventing the intrusion of moisture vapor from your below-slab environment. Stego Wrap Vapor Barrier offers the level of protection that many architects are now seeking and is considered to be inexpensive insurance against these costly failures.

LONGEVITY AND STRENGTH:

Stego Wrap Vapor Barrier is NOT made with recycled materials and will not degrade. Prime, virgin resins are the key. Molecules within Stego Wrap "interlock" to provide strength, durability and unprecedented resistance to moisture vapor and radon gas. Stego Wrap's puncture resistance is excellent. Stego Wrap will not tear, crack, flake, snag or puncture, even when 18,000 lb. laser-screed machines are driving directly across the barrier (see the reverse side for Stego Wrap Vapor Barrier's specifications).

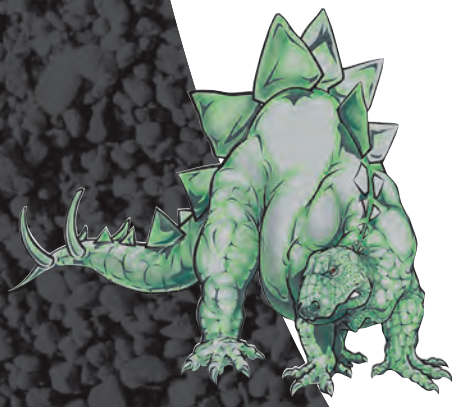

STEGO® WRAP VAPOR BARRIER SPECIFICATIONS

PROPERTIES	TEST METHOD	ASTM E 1745 Class A Requirements	TEST RESULT	EXPLANATION
Permeance	ASTM F 1249	0.1 perms	0.0086 perms * 0.0036 WVTR	Very impermeable to water vapor
Puncture Resistance	ASTM D 1709	2200 grams	Method B 2266 grams	Resistant to puncturing from construction abuse
Tensile Strength	ASTM D 882	45.0 lbf./in.	70.6 lbf./in.	Will not tear easily
Permeance After Conditioning (ASTM E 1745 Sections 7.1.2 - 7.1.5)	ASTM E 154 section 8	0.1 perms	0.0098 perms	Permeance after wetting, drying, and soaking
	ASTM E 154 section 11	0.1 perms	0.0091 perms	Permeance after heat conditioning
	ASTM E 154 section 12	0.1 perms	0.0097 perms	Permeance after low temperature conditioning
	ASTM E 154 section 13	0.1 perms	0.0095 perms	Permeance after soil organism exposure
Methane Transmission Rate	ASTM D 1434		**GTR = 192.8 mL(STP)/m ² *day	Greatly impedes the transmission of methane gas
Radon Diffusion Coefficient			5.5 x 10 ⁻¹⁴ m ² /second	Greatly impedes the transmission of radon gas
Thickness			15 mils	Stronger, tougher and less permeable than much thicker membranes
Roll Dimensions			14 ft. X 140 ft.	1,960 ft ² /roll - allows for a minimum of seams
Roll Weight			140 lbs.	Easy to unroll and install

Note: perm unit = grains/(ft² *hr* in.Hg) * WVTR = water vapor transmission rate **GTR = Gas Transmission Rate

INSTALLATION INSTRUCTIONS: (Based on ASTM E 1643)

Unroll Stego Wrap over the area where the slab is to be placed. Stego Wrap should completely cover the concrete placement area. Overlap seams 6 inches and tape using Stego Tape. All penetrations and blockouts should be sealed using a combination of Stego Wrap, Stego Tape and/or Stego Mastic. If the Stego Wrap is damaged, cut a piece from the Stego Wrap roll, place over the damaged area, and tape around all edges. Concrete may be placed directly on Stego Wrap. For additional information, please refer to Stego's complete installation instructions.

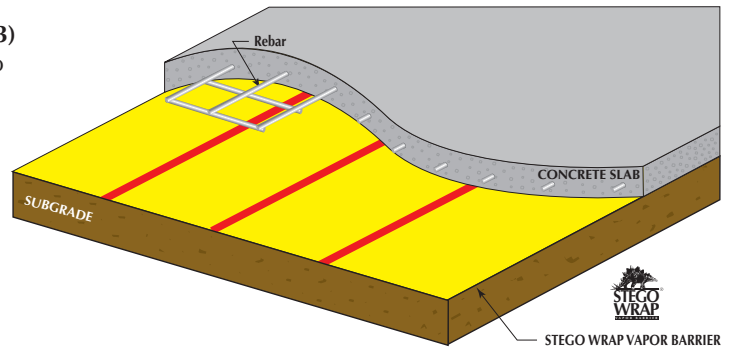

STEGO® TAPE:

STEGO WRAP RED POLYETHYLENE TAPE (3.75" x 180'/roll) is specially designed to seal seams and penetrations on Stego Wrap installations. The acrylic, pressure-sensitive adhesive provides permanent bonding and quick-stick properties. The area to be bonded should be free of dust, dirt and moisture.

WARRANTY:

STEGO INDUSTRIES, LLC believes, to the best of its knowledge, that specifications and recommendations herein are accurate and reliable. However, since site conditions and installations are not within our control, STEGO INDUSTRIES, LLC does not guarantee results from use of the information provided and disclaims all liability from any loss or damage. NO WARRANTY EXPRESS OR IMPLIED IS GIVEN AS TO THE MERCHANTABILITY, FITNESS FOR PARTICULAR PURPOSE, OR OTHERWISE WITH RESPECT TO THE PRODUCTS REFERRED TO.

Note: Test results above are for Stego Wrap products made as of March 15, 2013. If you have product made prior to March 15, 2013, please refer to Stego literature dated 10/12 for representative test results or call your local Stego Representative with questions.

Stego, the stegosaurus logo, Crete Claw, and StegoTack are all deemed to be registered and protectable trademarks of Stego Industries, LLC.



Stego® Wrap Vapor Barrier

STEGO INDUSTRIES, LLC



Vapor Retarders
07 26 00, 03 30 00

1. Product Name
Stego Wrap Vapor Barrier

2. Manufacturer
 Stego Industries, LLC
 216 Avenida Fabricante, Suite 101
 San Clemente, CA 92672
 Sales, Technical Assistance
 Ph: (877) 464-7834
 Fx: (949) 257-4113
 www.stegoindustries.com

3. Product Description
 USES: Stego Wrap Vapor Barrier is used as a below-slab vapor barrier.
 COMPOSITION: Stego Wrap Vapor Barrier is a multi-layer plastic extrusion manufactured with only high grade prime, virgin, polyolefin resins.
 ENVIRONMENTAL FACTORS: Stego Wrap Vapor Barrier can be used in systems for the control of soil gases (radon, methane), soil poisons (oil by-products) and sulfates.

5. Installation
 UNDER SLAB: Unroll Stego Wrap Vapor Barrier over an aggregate, sand or tamped earth base. Overlap all seams a minimum of six inches and tape using Stego Tape or Crete Claw® Tape. All penetrations must be sealed using a combination of Stego Wrap and Stego accessories.

For additional information, please refer to Stego's complete installation instructions.

6. Availability & Cost
 Stego Wrap Vapor Barrier is available nationally via building supply distributors. For current cost information, contact your local Stego Wrap distributor or Stego Industries' sales department.

7. Warranty
 Stego Industries, LLC believes to the best of its knowledge, that specifica-

tions and recommendations herein are accurate and reliable. However, since site conditions are not within its control, Stego Industries does not guarantee results from the use of the information provided and disclaims all liability from any loss or damage. No warranty, express or implied, is given as to the merchantability, fitness for a particular purpose, or otherwise with respect to the products referred to.

8. Maintenance
 None required.

9. Technical Services
 Technical advice, custom CAD drawings, and additional information can be obtained by contacting Stego Industries' technical assistance department or via the website.

- 10. Filing Systems**
- Stego Industries' website
 - Buildsite
 - 4Specs

4. Technical Data

TABLE 1: PHYSICAL PROPERTIES OF STEGO WRAP VAPOR BARRIER

PROPERTY	TEST	RESULTS
Under Slab Vapor Retarders	ASTM E 1745 Class A, B & C - Standard Specification for Water Vapor Retarders Used in Contact with Soil or Granular Fill under Concrete Slabs	Exceeds Class A, B & C
Water Vapor Permeance	ASTM F 1249 - Test Method for Water Vapor Transmission Rate Through Plastic Film and Sheeting Using a Modulated Infrared Sensor	0.0086 perms *0.0036 WVTR
Puncture Resistance	ASTM D 1709 - Test Methods for Impact Resistance of Plastic Film by Free-Falling Dart Method	2266 grams
Tensile Strength	ASTM D 882 - Test Method for Tensile Properties of Thin Plastic Sheeting	70.6 lbf/in.
Permeance After Conditioning (ASTM E 1745 Sections 7.1.2 - 7.1.5)	ASTM E 154 Section 8, F 1249 - Permeance after wetting, drying, and soaking ASTM E 154 Section 11, F 1249 - Permeance after heat conditioning ASTM E 154 Section 12, F 1249 - Permeance after low temperature conditioning ASTM E 154 Section 13, F 1249 - Permeance after soil organism exposure	0.0098 perms 0.0091 perms 0.0097 perms 0.0095 perms
Methane Transmission Rate	ASTM D 1434 - Standard Test Method for Determining Gas Permeability Characteristics of Plastic Film and Sheeting	**192.8 GTR mL(STP)/m ² *day
Radon Diffusion Coefficient		5.5 x 10 ⁻¹⁴ m ² /second
Thickness	ACI 302.1R-04 - Minimum Thickness (10 mils)	15 mils
Roll Dimensions		14 ft. wide x 140 ft. long or 1,960 ft ²
Roll Weight		140 lbs.

Note: perm unit = grains/(ft² *hr* in.Hg) * WVTR = Water Vapor Transmission Rate ** GTR = Gas Transmission Rate

Note: Test results above are for Stego Wrap products made as of March 15, 2013. If you have product made prior to March 15, 2013 please refer to Stego literature dated 10/12 for representative test results or call your local Stego Representative with questions.





Stego® Wrap Class A Vapor Retarder

STEGO INDUSTRIES, LLC



Vapor Retarders
07 26 00, 03 30 00

1. Product Name

**Stego Wrap Class A
Vapor Retarder**

2. Manufacturer

Stego Industries, LLC
216 Avenida Fabricante, Suite 101
San Clemente, CA 92672
Sales, Technical Assistance
Ph: (877) 464-7834
Fx: (949) 257-4113
www.stegoindustries.com

3. Product Description

USES: Stego Wrap Class A is used as an exceptional vapor retarder.
COMPOSITION: Stego Wrap Class A is a multi-layer plastic extrusion manufactured with only high grade prime, virgin, polyolefin resins.
ENVIRONMENTAL FACTORS: Stego Wrap Class A can be used in systems for the control of soil gases (radon, methane), soil poisons (oil by-products) and sulfates.

5. Installation

UNDER SLAB: Unroll Stego Wrap Class A over an aggregate, sand or tamped earth base. Overlap all seams a minimum of six inches and tape using Stego Tape or Crete Claw® Tape. All penetrations must be sealed using a combination of Stego Wrap and Stego accessories.

For additional information, please refer to Stego's complete installation instructions.

6. Availability & Cost

Stego Wrap Class A is available nationally via building supply distributors. For current cost information, contact your local Stego Wrap distributor or Stego Industries' sales department.

7. Warranty

Stego Industries, LLC believes to the best of its knowledge, that specifications and recommendations herein are

accurate and reliable. However, since site conditions are not within its control, Stego Industries does not guarantee results from the use of the information provided and disclaims all liability from any loss or damage. No warranty, express or implied, is given as to the merchantability, fitness for a particular purpose, or otherwise with respect to the products referred to.

8. Maintenance

None required.

9. Technical Services

Technical advice, custom CAD drawings, and additional information can be obtained by contacting Stego Industries' technical assistance department or via the website.

10. Filing Systems

- Stego Industries' website
- Buildsite
- 4Specs

4. Technical Data

TABLE 1: PHYSICAL PROPERTIES OF STEGO WRAP CLASS A VAPOR RETARDER

PROPERTY	TEST	RESULTS
Under Slab Vapor Retarders	ASTM E 1745 Class A, B & C – Standard Specification for Water Vapor Retarders Used in Contact with Soil or Granular Fill under Concrete Slabs	Exceeds Class A, B & C
Water Vapor Permeance	ASTM F 1249 – Test Method for Water Vapor Transmission Rate Through Plastic Film and Sheeting Using a Modulated Infrared Sensor	0.0254 perms
Puncture Resistance	ASTM D 1709 – Test Methods for Impact Resistance of Plastic Film by Free-Falling Dart Method	3466 grams
Tensile Strength	ASTM D 882 – Test Method for Tensile Properties of Thin Plastic Sheeting	50.60 lbf/in.
Permeance After Conditioning (ASTM E 1745 Sections 7.1.2 - 7.1.5)	ASTM E 154 Section 8, F 1249 – Permeance after wetting, drying, and soaking ASTM E 154 Section 11, F 1249 – Permeance after heat conditioning ASTM E 154 Section 12, F 1249 – Permeance after low temperature conditioning ASTM E 154 Section 13, F 1249 – Permeance after soil organism exposure	0.0258 perms 0.0259 perms 0.0241 perms 0.0245 perms
Thickness	ACI 302.1R-04 – Minimum Thickness (10 mils)	10 mils
Roll Dimensions		14 ft. wide x 210 ft. long or 2,940 ft ²
Roll Weight		140 lbs.

Note: perm unit = grains/(ft² *hr* in.Hg)

Test results above are for Stego Wrap products made as of March 15, 2013. If you have product made prior to March 15, 2013 please refer to Stego literature dated 10/12 for representative test results or call your local Stego Representative with questions.





Stego® Tape
 STEGO INDUSTRIES, LLC



Vapor Retarders
07 26 00, 03 30 00

1. Product Name
 Stego Tape

2. Manufacturer

Stego Industries, LLC
 216 Avenida Fabricante, Suite 101
 San Clemente, CA 92672
 Sales, Technical Assistance
 Ph: (877) 464-7834
 Fx: (949) 257-4113
 www.stegoindustries.com

3. Product Description

USES: Stego Tape is a low permeance tape designed for protective sealing, hanging, seaming, splicing, and patching applications where a highly conformable material is required. It has been engineered to bond specifically to Stego Wrap, making it ideal for sealing Stego Wrap seams and penetrations.

COMPOSITION: Stego Tape is composed of polyethylene film and an acrylic, pressure-sensitive adhesive.

SIZE: Stego Tape is 3.75" wide and 180' long. Stego Tape ships 12 rolls in a case.

4. Technical Data

APPLICABLE STANDARDS:

Pressure Sensitive Tape Council (PSTC)

- PSTC 101 – International Standard for Peel Adhesion of Pressure Sensitive Tape

American Society for Testing & Materials (ASTM)

- ASTM E 1643 - Standard Practice for Selection, Design, Installation, and Inspection of Water Vapor Retarders Used in Contact with Earth or Granular Fill under Concrete Slabs

5. Installation

SEAMS:

Overlap Stego Wrap six inches and seal with Stego Tape. Make sure the area of adhesion is free from dust, dirt, moisture and frost to allow maximum adhesion of the pressure sensitive tape.

PIPE PENETRATION SEALING

- 1) Install Stego Wrap around pipe by slitting/cutting material
- 2) If void space around pipe is minimal, seal around base of pipe with Stego Tape (Stego Mastic can be used for additional coverage)

DETAIL PATCH FOR PIPE PENETRATION SEALING

- 1) Cut a piece of Stego Wrap that creates a six inch overlap around all edges of the void space
- 2) Cut an "X" in the center of the detail patch
- 3) Slide detail patch over pipe, secure tightly
- 4) Tape down all sides of detail patch with Stego Tape
- 5) Seal around base of pipe with Stego Tape (Stego Mastic can be used for additional coverage)

Stego Tape should be installed above 40°F. In temperatures below 40°F, take extra care to remove moisture or frost from the area of adhesion.

For additional information, please refer to Stego's complete installation instructions.



6. Availability & Cost

Stego Tape is available nationally via building supply distributors. For current cost information, contact your local Stego distributor or Stego Industries' sales department.

7. Warranty

Stego Industries, LLC believes to the best of its knowledge, that specifications and recommendations herein are accurate and reliable. However, since site conditions are not within its control, Stego Industries does not guarantee results from the use of the information provided and disclaims all liability from any loss or damage. No warranty, express or implied, is given as to the merchantability, fitness for a particular purpose, or otherwise with respect to the products referred to.

8. Maintenance

None required.

9. Technical Services

Technical advice, custom CAD drawings, and additional information can be obtained by contacting Stego Industries' technical assistance department or by visiting the website.

10. Filing Systems

- Stego Industries' website
- Buildsite

TABLE 1: PHYSICAL PROPERTIES OF STEGO TAPE

PROPERTY	RESULTS
Total Thickness	6 mils
Permeance	0.03 perms
Tensile Strength	17 lbs./in. width
Elongation (at break) MD	1060%
Adhesion (20 min dwell ss, PSTC 101)	95-oz./in. width
Ultraviolet Resistance	Excellent





Stego® Wrap Class C Vapor Retarder

STEGO INDUSTRIES, LLC



Vapor Retarders
07 26 00, 03 30 00

1. Product Name

**Stego Wrap Class C
Vapor Retarder**

2. Manufacturer

Stego Industries, LLC
216 Avenida Fabricante, Suite 101
San Clemente, CA 92672
Sales, Technical Assistance
Ph: (877) 464-7834
Fx: (949) 257-4113
www.stegoindustries.com

3. Product Description

USES: Stego Wrap Class C is used as an exceptional vapor retarder.
COMPOSITION: Stego Wrap Class C is a multi-layer plastic extrusion manufactured with only high grade prime, virgin, polyolefin resins.
ENVIRONMENTAL FACTORS: Stego Wrap Class C can be used in systems for the control of soil gases (radon, methane), soil poisons (oil by-products) and sulfates.

5. Installation

UNDER SLAB: Unroll Stego Wrap Class C over an aggregate, sand or tamped earth base. Overlap all seams a minimum of six inches and tape using Stego Tape or Crete Claw® Tape. All penetrations must be sealed using a combination of Stego Wrap and Stego accessories.

For additional information, please refer to Stego's complete installation instructions.

6. Availability & Cost

Stego Wrap Class C is available nationally via building supply distributors. For current cost information, contact your local Stego Wrap distributor or Stego Industries' sales department.

7. Warranty

Stego Industries, LLC believes to the best of its knowledge, that specifications and recommendations herein are

accurate and reliable. However, since site conditions are not within its control, Stego Industries does not guarantee results from the use of the information provided and disclaims all liability from any loss or damage. No warranty, express or implied, is given as to the merchantability, fitness for a particular purpose, or otherwise with respect to the products referred to.

8. Maintenance

None required.

9. Technical Services

Technical advice, custom CAD drawings, and additional information can be obtained by contacting Stego Industries' technical assistance department or via the website.

10. Filing Systems

- Stego Industries' website
- Buildsite
- 4Specs

4. Technical Data

TABLE 1: PHYSICAL PROPERTIES OF STEGO WRAP CLASS C VAPOR RETARDER

PROPERTY	TEST	RESULTS
Under Slab Vapor Retarders	ASTM E 1745 Class A, B & C - Standard Specification for Water Vapor Retarders Used in Contact with Soil or Granular Fill under Concrete Slabs	Exceeds Class C
Water Vapor Permeance	ASTM F 1249 - Test Method for Water Vapor Transmission Rate Through Plastic Film and Sheeting Using a Modulated Infrared Sensor	0.0209 perms
Puncture Resistance	ASTM D 1709 - Test Methods for Impact Resistance of Plastic Film by Free-Falling Dart Method	1286 grams
Tensile Strength	ASTM D 882 - Test Method for Tensile Properties of Thin Plastic Sheeting	49.16 lbf/in.
Permeance After Conditioning (ASTM E 1745 Sections 7.1.2 - 7.1.5)	ASTM E 154 Section 8, F 1249 - Permeance after wetting, drying, and soaking ASTM E 154 Section 11, F 1249 - Permeance after heat conditioning ASTM E 154 Section 12, F 1249 - Permeance after low temperature conditioning ASTM E 154 Section 13, F 1249 - Permeance after soil organism exposure	0.0226 perms 0.0222 perms 0.0214 perms 0.0214 perms
Thickness	ACI 302.1R-04 - Minimum Thickness (10 mils)	10 mils
Roll Dimensions		14 ft. wide x 210 ft. long or 2,940 ft ²
Roll Weight		140 lbs.

Note: perm unit = grains/(ft² *hr* in.Hg)

Test results above are for Stego Wrap products made as of March 15, 2013. If you have product made prior to March 15, 2013 please refer to Stego literature dated 10/12 for representative test results or call your local Stego Representative with questions.





StegoTack® Tape

STEGO INDUSTRIES, LLC



Vapor Retarders
07 26 00, 03 30 00

1. Product Name

StegoTack® Tape

2. Manufacturer

Stego Industries, LLC
 216 Avenida Fabricante, Suite 101
 San Clemente, CA 92672
 Sales, Technical Assistance
 Ph: (877) 464-7834
 Fx: (949) 257-4113
www.stegoindustries.com

3. Product Description

USES: StegoTack Tape is a double-sided adhesive strip used to bond and seal Stego Wrap to concrete, masonry, wood, metal, and other surfaces. StegoTack is a flexible and moldable material to allow for a variety of applications and installations.

COMPOSITION: StegoTack Tape is made from a blend of synthetic rubber and resins. **SIZE:** StegoTack Tape is 2 inches wide and 50 feet long. StegoTack Tape ships 12 rolls in a case.

5. Installation

TO WALLS: Make sure the area of

adhesion is free of dust, dirt, debris, moisture, and frost to allow maximum adhesion. Remove release liner on one side and stick to desired surface. When ready to apply Stego Wrap, remove the exposed release liner and press Stego Wrap firmly against StegoTack Tape to secure.

TO FOOTINGS: Make sure the area of adhesion is free of dust, dirt, debris, moisture, and frost to allow maximum adhesion. Remove release liner on one side and stick to desired surface. When ready to apply Stego Wrap, remove the exposed release liner and press Stego Wrap firmly against StegoTack Tape to secure.

Cut StegoTack Tape using a utility knife or scissors. Cut StegoTack Tape before removing the release liner for easier cutting. Install StegoTack Tape between 40°F and 110°F. For additional information please refer to Stego's complete installation instructions.

6. Availability & Cost

StegoTack Tape is available nationally through our network of building supply distributors. For current cost information, contact your local Stego

Wrap distributor or Stego Industries' Sales Representative.

7. Warranty

Stego Industries, LLC believes to the best of its knowledge, that specifications and recommendations herein are accurate and reliable. However, since site conditions are not within its control, Stego Industries does not guarantee results from the use of the information provided and disclaims all liability from any loss or damage. No warranty, express or implied, is given as to the merchantability, fitness for a particular purpose, or otherwise with respect to the products referred to.

8. Maintenance

For longer adhesive life, store in dry, temperate area.

9. Technical Services

Technical advice, custom CAD drawings, and additional information can be obtained by contacting Stego Industries' technical assistance department or via the website. www.stegoindustries.com

10. Filing Systems

www.stegoindustries.com
 Buildsite

4. Technical Data

TABLE 1: PHYSICAL PROPERTIES OF STEGOTACK TAPE

PROPERTY	RESULTS
Dimensions	50 feet long, 2 inches wide
Total Thickness	30 Mils
Permeance	0.03 perms (30 mils)
Color	Grey
Material	Synthetic rubber blend
Adhesion to Steel	10.3 lbs./in. width ASTM C 1000
Installation Temperature	40°F/110°F (4°C/43°C)
In Service Temperature Range	-20°F/+140°F (-29°C/60°C)
VOC Content	No VOC's, 100% solids





Stego® Pre-Cut Pipe Boots

STEGO INDUSTRIES, LLC

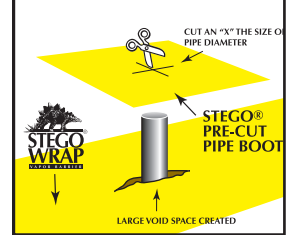

Vapor Retarders
07 26 00, 03 30 00

1. Product Name

Stego Pre-Cut Pipe Boots

2. Manufacturer

Stego Industries, LLC
216 Avenida Fabricante, Suite 101
San Clemente, CA 92672
Sales, Technical Assistance
Ph: (877) 464-7834
Fx: (949) 257-4113
www.stegoindustries.com

3. Product Description

USES: Stego Pre-Cut Pipe Boots are used to seal around permanent penetrations in Stego Wrap.

COMPOSITION: Stego Pre-Cut Pipe Boots are made from Stego Wrap Vapor Barrier (15-mil), and therefore are manufactured from only high grade prime, virgin, polyolefin resins.

SIZE: Stego Pre-Cut Pipe Boots are 18" by 18" and 15 mils thick. Stego Pre-Cut Pipe Boots ship 10 packs of 25 in a case (250 boots per case).

5. Installation

UNDER SLAB: Cut an "X" the size of the pipe diameter in the center of the Pre-Cut Pipe Boot and slide tightly over pipe. Tape all sides of the pipe boot with Stego Tape. Seal around the base of the pipe using Stego tape and/or Stego Mastic.

For additional information, please refer to Stego's complete installation instructions.

6. Availability & Cost

Stego Pre-Cut Pipe Boots are available nationally through our network of building supply distributors. For current cost information, contact your local Stego Wrap distributor or Stego Industries' Sales Representative.

7. Warranty

Stego Industries, LLC believes to the best of its knowledge, that specifications and recommendations herein are accurate and reliable. However, since

site conditions are not within its control, Stego Industries does not guarantee results from the use of the information provided and disclaims all liability from any loss or damage. No warranty, express or implied, is given as to the merchantability, fitness for a particular purpose, or otherwise with respect to the products referred to.

8. Maintenance

None required.

9. Technical Services

Technical advice, custom CAD drawings, and additional information can be obtained by contacting Stego Industries' technical assistance department or via the website. www.stegoindustries.com

4. Technical Data

TABLE 1: PHYSICAL PROPERTIES OF STEGO PRE-CUT PIPE BOOTS

PROPERTY	TEST	RESULTS
Under Slab Vapor Retarders	ASTM E 1745 Class A, B & C - Standard Specification for Water Vapor Retarders Used in Contact with Soil or Granular Fill under Concrete Slabs	Exceeds Class A, B & C
Water Vapor Permeance	ASTM F 1249 - Test Method for Water Vapor Transmission Rate Through Plastic Film and Sheeting Using a Modulated Infrared Sensor	0.0086 perms *0.0036 WVTR
Puncture Resistance	ASTM D 1709 - Test Methods for Impact Resistance of Plastic Film by Free-Falling Dart Method	2266 grams
Tensile Strength	ASTM D 882 - Test Method for Tensile Properties of Thin Plastic Sheeting	70.60 lbf/in.
Permeance After Conditioning (ASTM E 1745 Sections 7.1.2 - 7.1.5)	ASTM E 154 Section 8, F 1249 - Permeance after wetting, drying, and soaking ASTM E 154 Section 11, F 1249 - Permeance after heat conditioning ASTM E 154 Section 12, F 1249 - Permeance after low temperature conditioning ASTM E 154 Section 13, F 1249 - Permeance after soil organism exposure	0.0098 perms 0.0091 perms 0.0097 perms 0.0095 perms
Thickness	ACI 302.1R-04 - Minimum Thickness (10 mils)	15 mils
Pipe Boot Dimensions		18" x 18"

Note: perm unit = grains/(ft² *hr* in.Hg) * WVTR = Water Vapor Transmission Rate



PART 1

STEGO WRAP VAPOR BARRIER/RETARDER INSTALLATION INSTRUCTIONS



IMPORTANT: Please read these installation instructions completely, prior to beginning any Stego Wrap installation. The following installation instructions are based on ASTM E 1643 - Standard Practice for Selection, Design, Installation, and Inspection of Water Vapor Retarders Used in Contact with Earth or Granular Fill Under Concrete Slabs. If project specifications call for compliance with ASTM E 1643, then be sure to review the specific installation sections outlined in the standard along with the techniques referenced in these instructions.

FIGURE 1: UNDER-SLAB INSTALLATION

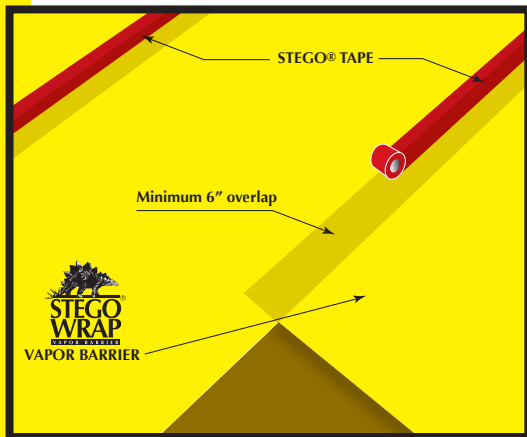

UNDER-SLAB INSTRUCTIONS:

1. Stego Wrap can be installed over an aggregate, sand, or tamped earth base. It is not necessary to have a cushion layer or sand base, as Stego Wrap is tough enough to withstand rugged construction environments.
2. Unroll Stego Wrap over the area where the slab is to be placed. Stego Wrap should completely cover the concrete placement area. All joints/seams both lateral and butt should be overlapped a minimum of six inches and taped using Stego Tape.

NOTE: The area of adhesion should be free from dust, dirt, moisture, and frost to allow maximum adhesion of the pressure-sensitive tape.

3. ASTM E 1643 requires sealing the perimeter of the slab. *Extend vapor retarder over footings and seal to foundation wall, grade beam, or slab at an elevation consistent with the top of the slab or terminate at impediments such as waterstops or dowels.* Consult the structural engineer of record before proceeding.

SEAL TO SLAB AT PERIMETER:*

NOTE: Clean the surface of Stego Wrap to ensure that the area of adhesion is free from dust, dirt, moisture, and frost to allow maximum adhesion of the pressure-sensitive adhesive.

- a. Install Crete Claw® on the entire perimeter edge of Stego Wrap.
- b. Prior to the placement of concrete, ensure that the top of Crete Claw is free of dirt, debris, or mud to maximize the bond to the concrete.

STEGO LABOR SAVER!

This method not only complies with ASTM E 1643, but it also:

- reduces labor compared to other perimeter sealing techniques.
- can be used even without an existing wall or footing, unlike alternatives.

FIGURE 2a: SEAL TO SLAB AT PERIMETER

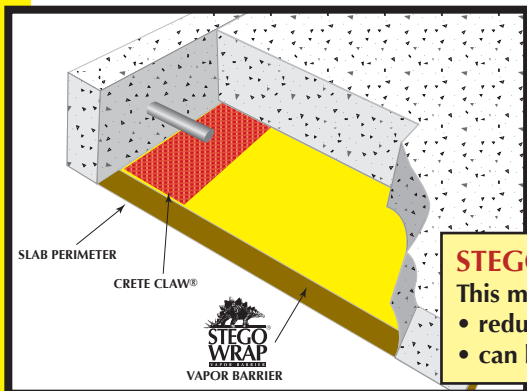

FIGURE 2b: SEAL TO PERIMETER WALL

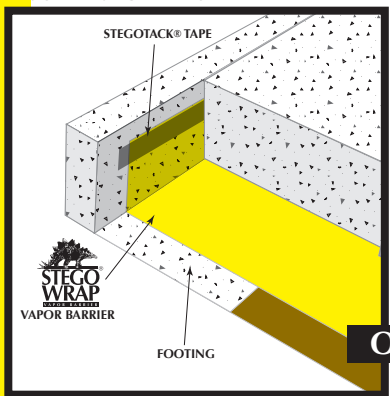
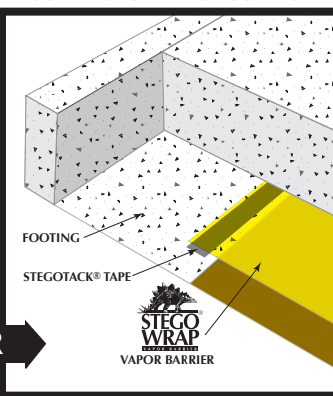

FIGURE 2c: SEAL TO FOOTING



OR SEAL TO PERIMETER WALL OR FOOTING WITH STEGOTACK® TAPE:*

- a. Make sure area of adhesion is free of dust, dirt, debris, moisture, and frost to allow maximum adhesion.
- b. Remove release liner on one side and stick to desired surface.
- c. When ready to apply Stego Wrap, remove the exposed release liner and press Stego Wrap firmly against StegoTack Tape to secure.

* If ASTM E 1643 is specified, consult with project architect and structural engineer to determine which perimeter seal technique should be employed for the project.

NOTE: Stego Industries, LLC's ("Stego") installation instructions are based on ASTM E 1643 - Standard Practice for Selection, Design, Installation, and Inspection of Water Vapor Retarders Used in Contact with Earth or Granular Fill Under Concrete Slabs. These instructions are meant to be used as a guide, and do not take into account specific job site situations. Consult local building codes and regulations along with the building owner or owner's representative before proceeding. If you have any questions regarding the above mentioned installation instructions or Stego products, please call us at 877-464-7834 for technical assistance. While Stego employees and representatives may provide technical assistance regarding the utility of a specific installation practice or Stego product, they are not authorized to make final design decisions.

- In the event that Stego Wrap is damaged during or after installation, repairs must be made. Stego Tape can be used to repair small holes in the material. For larger holes, cut a piece of Stego Wrap to a size and shape that covers any damage by a minimum overlap of six inches in all directions. Clean all adhesion areas of dust, dirt, moisture, and frost. Tape down all edges using Stego Tape (see figure 3, Sealing Damaged Areas).

FIGURE 3: SEALING DAMAGED AREAS



- IMPORTANT: ALL PENETRATIONS MUST BE SEALED.** All pipe, ducting, rebar, wire penetrations and block outs should be sealed using Stego Wrap, Stego Tape and/or Stego Mastic (see figure 4a, Pipe Penetration Sealing).

FIGURE 4a: PIPE PENETRATION SEALING

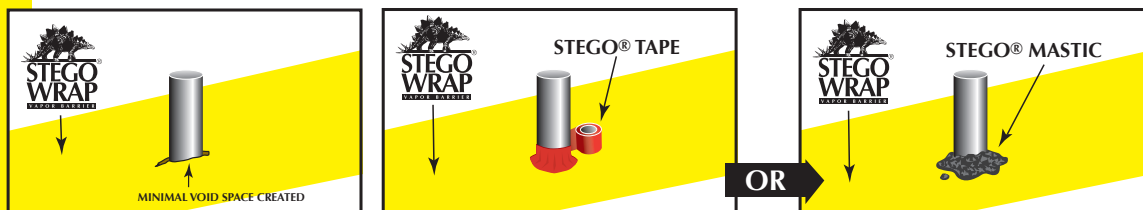

STEGO WRAP PIPE PENETRATION REPAIR DETAIL:

- 1: Install Stego Wrap around pipe penetrations by slitting/cutting material as needed. Try to minimize the void space created.
- 2: If Stego Wrap is close to pipe and void space is minimized then seal around pipe penetration with Stego Tape and/or Stego Mastic. **[See Figure 4a]**
- 3: If detail patch is needed to minimize void space around penetration, then cut a detail patch to a size and shape that creates a six inch overlap on all edges around the void space at the base of the pipe. Stego Pre-Cut Pipe Boots are also available to speed up the installation.
- 4: Cut an "X" the size of the pipe diameter in the center of the pipe boot and slide tightly over pipe.
- 5: Tape down all sides of the pipe boot with Stego Tape.
- 6: Seal around the base of the pipe using Stego Tape and/or Stego Mastic. **[See Figure 4b]**

FIGURE 4b: DETAIL PATCH FOR PIPE PENETRATION SEALING

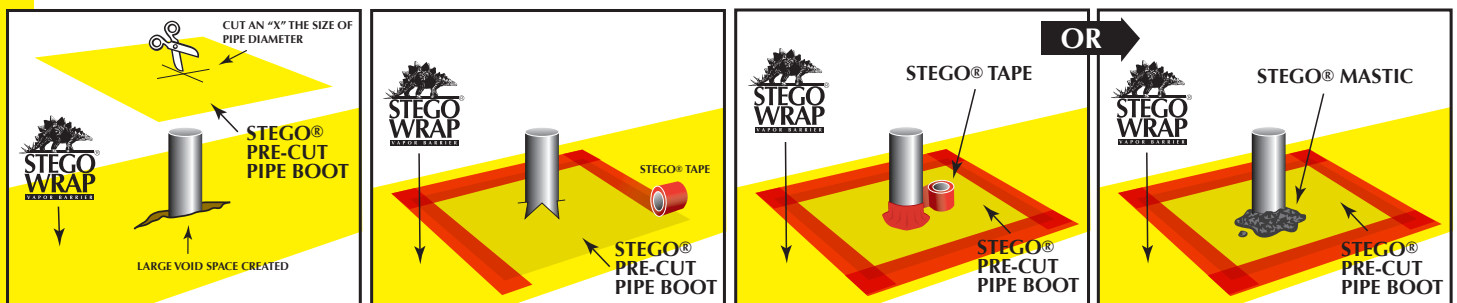
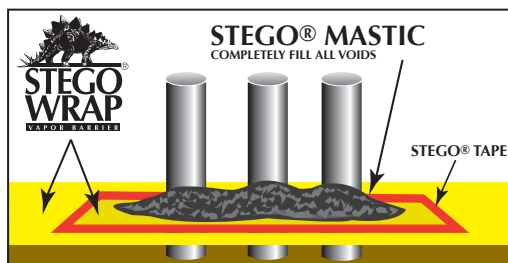

FIGURE 5: MULTIPLE PIPE PENETRATION SEALING



MULTIPLE PIPE PENETRATION SEALING:

Multiple pipe penetrations in close proximity and very small pipes may be sealed using Stego Wrap and Stego Mastic for ease of installation (see figure 5, Multiple Pipe Penetration Sealing).

NOTE: Stego Industries, LLC's ("Stego") installation instructions are based on ASTM E 1643 - *Standard Practice for Selection, Design, Installation, and Inspection of Water Vapor Retarders Used in Contact with Earth or Granular Fill Under Concrete Slabs*. These instructions are meant to be used as a guide, and do not take into account specific job site situations. Consult local building codes and regulations along with the building owner or owner's representative before proceeding. If you have any questions regarding the above mentioned installation instructions or Stego products, please call us at 877-464-7834 for technical assistance. While Stego employees and representatives may provide technical assistance regarding the utility of a specific installation practice or Stego product, they are not authorized to make final design decisions.

PART 2

STEGO WRAP VAPOR BARRIER/RETARDER INSTALLATION INSTRUCTIONS



CRAWL SPACE INSTALLATION INSTRUCTIONS:

1. Turn Stego Wrap up the foundation wall to a minimum height of six inches above the outside/exterior grade or in compliance with local building codes and terminate with Stego Term Bar. To form a complete seal, apply StegoTack Tape or a layer of Stego Mastic to the foundation wall prior to installing Stego Term Bar. Allow one hour for Stego Mastic to cure prior to installing Stego Term Bar.
2. Seal Stego Wrap around all penetrations and columns using Stego Tape, StegoTack Tape, and/or Stego Mastic.
3. Place Stego Wrap directly over the crawl space floor. If rigid insulation is to be used, install Stego Wrap prior to insulation (under insulation and between the foundation wall and insulation).
4. Overlap seams a minimum of six inches and seal with Stego Tape. Some codes require a minimum of a twelve inch overlap. Check appropriate codes prior to installation.

FIGURE 6: CRAWL SPACE INSTALLATION

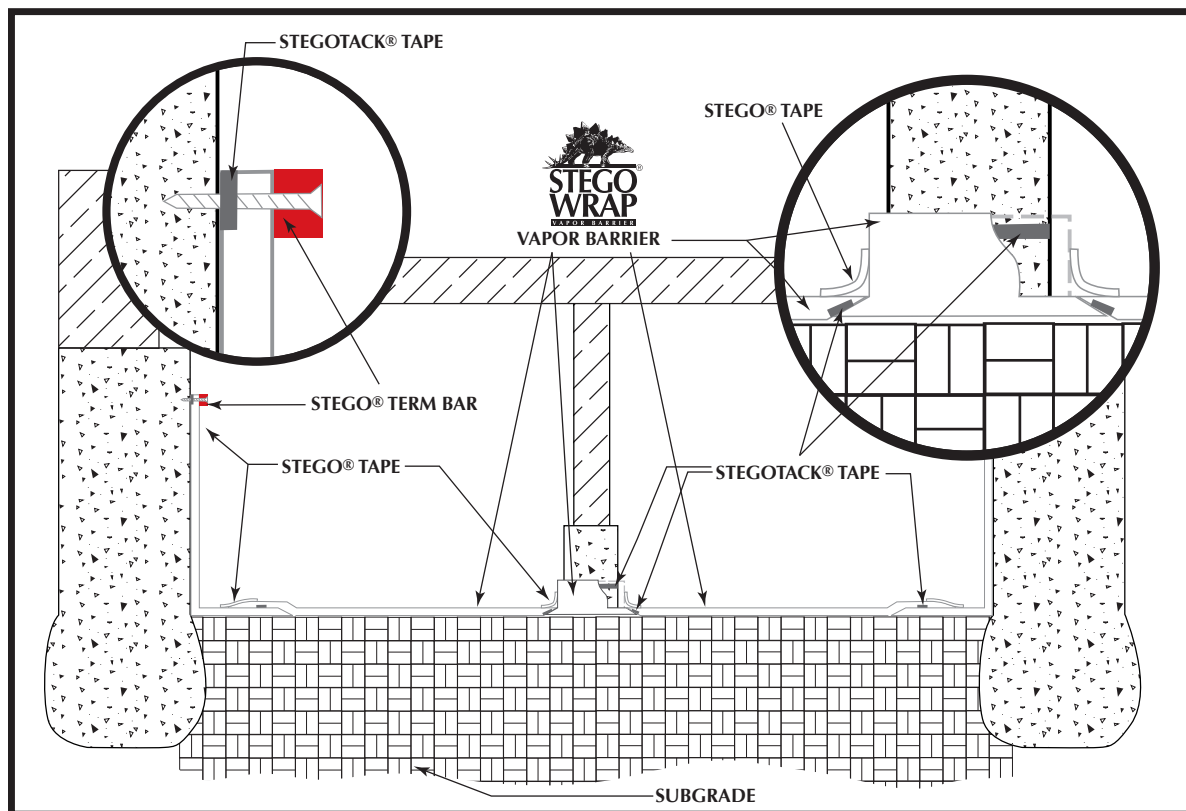

NOTE: Stego Wrap Vapor Barrier and Stego Tape are both available in white (as shown in illustration above).

INSTALLATION TIP:

1. For a cleaner look and to prevent against tenting of Stego Wrap at the foundation wall/foundation floor intersection, consider mechanically fastening Stego Wrap to base of foundation wall in addition to the above mentioned wall termination.

NOTE: Stego Industries, LLC's ("Stego") installation instructions are based on ASTM E 1643 - *Standard Practice for Selection, Design, Installation, and Inspection of Water Vapor Retarders Used in Contact with Earth or Granular Fill Under Concrete Slabs*. These instructions are meant to be used as a guide, and do not take into account specific job site situations. Consult local building codes and regulations along with the building owner or owner's representative before proceeding. If you have any questions regarding the above mentioned installation instructions or Stego products, please call us at 877-464-7834 for technical assistance. While Stego employees and representatives may provide technical assistance regarding the utility of a specific installation practice or Stego product, they are not authorized to make final design decisions.



Stego® Wrap 20-Mil Vapor Barrier

STEGO INDUSTRIES, LLC



Vapor Retarders
07 26 00, 03 30 00

1. Product Name

Stego Wrap 20-Mil Vapor Barrier

2. Manufacturer

Stego Industries, LLC
 216 Avenida Fabricante, Suite 101
 San Clemente, CA 92672
 Sales, Technical Assistance
 Ph: (877) 464-7834
 Fx: (949) 257-4113
www.stegoindustries.com

3. Product Description

USES: Stego Wrap 20-Mil Vapor Barrier is used as a below-slab vapor barrier, and as a protection course for below grade waterproofing applications.
COMPOSITION: Stego Wrap 20-Mil Vapor Barrier is a multi-layer plastic extrusion manufactured with only the highest grade of prime, virgin, polyolefin resins.
ENVIRONMENTAL FACTORS: Stego Wrap 20-Mil Vapor Barrier can be used in systems for the control of soil gases (radon, methane), soil poisons (oil by-products) and sulfates.

5. Installation

UNDER SLAB: Unroll Stego Wrap 20-Mil Vapor Barrier over an aggregate, sand or tamped earth base. Overlap all seams a minimum of six inches and tape using Stego Tape or Crete Claw® Tape. All penetrations must be sealed using a combination of Stego Wrap and Stego accessories.

For additional information, please refer to Stego's complete installation instructions.

6. Availability & Cost

Stego Wrap 20-Mil Vapor Barrier is available nationally via building supply distributors. For current cost information, contact your local Stego Wrap distributor or Stego Industries' sales department.

7. Warranty

Stego Industries, LLC believes to the best of its knowledge, that specifications and recommendations herein are

accurate and reliable. However, since site conditions are not within its control, Stego Industries does not guarantee results from the use of the information provided and disclaims all liability from any loss or damage. NO WARRANTY, EXPRESS, IMPLIED OR STATUTORY, IS GIVEN AS TO THE MERCHANTABILITY, FITNESS FOR A PARTICULAR PURPOSE, OR OTHERWISE WITH RESPECT TO THE PRODUCTS REFERRED TO. Please see www.stegoindustries.com/legal.

8. Maintenance

None required.

9. Technical Services

Technical advice, custom CAD drawings, and additional information can be obtained by contacting Stego Industries' technical assistance department or via the website.

10. Filing Systems

• www.stegoindustries.com



4. Technical Data

TABLE 1: PHYSICAL PROPERTIES OF STEGO WRAP 20-MIL VAPOR BARRIER

PROPERTY	TEST	RESULTS
Under Slab Vapor Retarders	ASTM E1745 Class A, B & C - Standard Specification for Water Vapor Retarders Used in Contact with Soil or Granular Fill under Concrete Slabs	Exceeds Class A, B & C
Water Vapor Permeance	ASTM F1249 - Test Method for Water Vapor Transmission Rate Through Plastic Film and Sheeting Using a Modulated Infrared Sensor	0.0071 perms
Puncture Resistance	ASTM D1709 - Test Methods for Impact Resistance of Plastic Film by Free-Falling Dart Method	3500+ grams*
Tensile Strength	ASTM D882 - Test Method for Tensile Properties of Thin Plastic Sheeting	97.7 lbf/in.
Permeance After Conditioning (ASTM E1745 Sections 7.1.2 - 7.1.5)	ASTM E154 Section 8, F1249 - Permeance after wetting, drying, and soaking ASTM E154 Section 11, F1249 - Permeance after heat conditioning ASTM E154 Section 12, F1249 - Permeance after low temperature conditioning ASTM E154 Section 13, F1249 - Permeance after soil organism exposure	0.0088 perms 0.0081 perms 0.0084 perms 0.0077 perms
Radon Diffusion Coefficient	K124/02/95	9.9 x 10 ⁻¹² m ² /second
Thickness		20 mils
Roll Dimensions		14 ft. wide x 105 ft. long or 1,470 ft ²
Roll Weight		140 lbs.

Note: perm unit = grains/(ft² *hr* in.Hg)

* The material maxed out the testing equipment and did not fail at 3746 grams.



Hurricane[®] Natural Ventilation





Established in 1934, Edmonds® is a pioneer in home, commercial and industrial ventilation solutions in Australia as well as across the globe.

Edmonds is passionate about delivering superior comfort and performance whilst reducing the overall impact on the environment. It is this vision of a 'sustainable future' which has resulted in the design and development of many energy efficient innovations. These include natural, wind-driven; hybrid and turbine ventilation technology.

Regarded as a leading industry innovator, Edmonds Ventilation products are engineered and manufactured at its ISO9001 accredited facility in Seven Hills, Australia. Edmonds was awarded the AIRAH Excellence in Sustainability Award in 2013 and Achiever Award in 2008. It was also recognised with a Good Design Award at the 2013 Australian International Design Awards and Master Builders Australia 2012 National Export Award.

With strong synergies between insulation and ventilation in the building industry, Edmonds was acquired by CSR Building Products Limited in 2005. Its mission remains to create Technologies for a Sustainable Future.



Hurricane® was installed in Indoor Swimming Centres to reduce condensation and humidity.



Hurricane (93 x H900) was installed at the Qantas Engineering Workshops, Mascot, Sydney to improve ventilation for employees.

Hurricane®

For over 25 years, the Hurricane® range of Australian-engineered natural ventilation technology has been built to endure the toughest of climatic conditions and operating environments.

From Melbourne to the Middle East and to the Midwest of USA, you can be confident that Hurricane will provide years of superior operation.



National Export Award for Edmonds Business



HVAC Achiever award for EcoPower®



Excellence in Sustainability award for Odyssey®



Global-Mark.com.au®
Quality Management standard for Edmonds Seven Hills facility

NATURAL VENTILATION TECHNOLOGY

Hurricane®

EFFECTIVE NO COST OPERATION

- Natural, wind-driven ventilation to maximise energy savings through free-air cooling.
- Improved indoor air quality by removing pollutants.
- Improved humidity control by removing moisture build-up.
- Improved occupant comfort by removing heat build-up.

HIGH PERFORMANCE EDMONDS VERTICAL VANE™ TECHNOLOGY

- Unique design allows wind turbine to act as a centrifugal impeller.
- Improved co-efficient of flow (Cf) compared to similar sized traditional spherical vents.

MATERIALS

- Marine grade equivalent aluminium as standard.
- Options for highly corrosive environments also available.
- Mill finish or powder coated options to match most COLORBOND® colours. Refer to Edmonds colour chart for available colours.
- Bearing system designed to prevent ingress of fine dust particulates in harsh environments.

INSTALLATION BENEFITS

- Significant weight advantage (<40kg). Two-person lift may be achieved versus crane-lift for heavier competitor options.
- Lightweight design means additional structural strengthening of roof may not be required.
- Variable pitch base design can adapt to most roof angles. Special Bases can be custom made for known roof pitch.

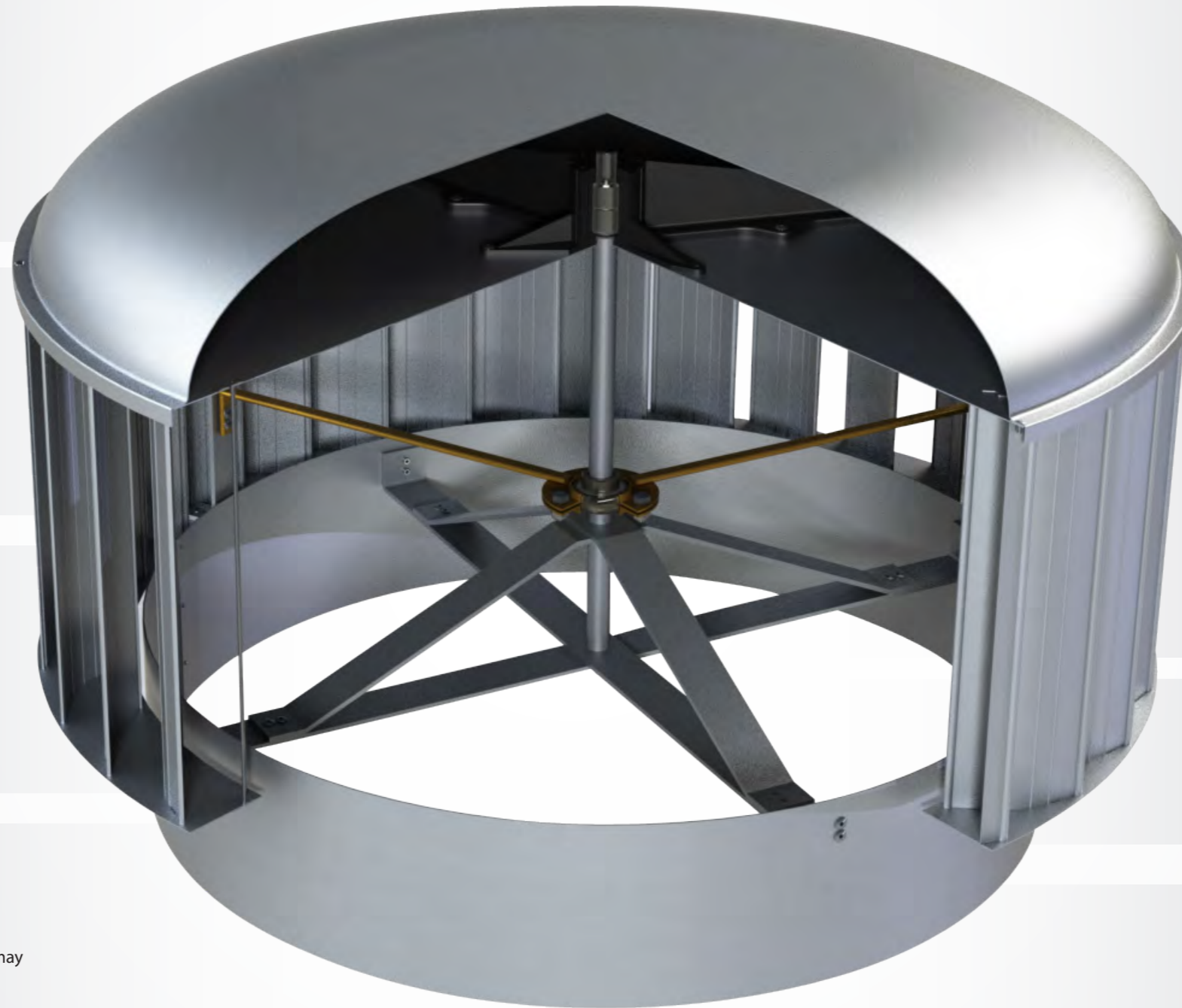

SPECIAL VARIATIONS



FR900 Fire-Rated option meets the fire-resistant test to AS 1668.1-1998. The use of ventilation and air conditioning in buildings, Part 1: Fire and smoke control in multi-compartment buildings Section 4.8. Smoke-Spill fan.



BFR Bush Fire Rated option for buildings in Bushfire Prone Vegetation Category 1 areas. It is designed to comply with the Deemed to Satisfy provisions of AS3959.



S2 Corrosion Resistant option for water reservoirs or environments that are oxidative or slightly acidic (non-caustic).



HI Heavy Industrial option with polyolefin coating for highly corrosive environments.

ACCESSORIES

- Manual or electric dampers
- Special Bases
- EC damper grilles

WARRANTY

15 year warranty on Hurricanes other than Special Variations and Accessories.

Please refer to edmonds.com.au for full warranty conditions.



Note: Image for illustrative purposes only.

APPLICATIONS

ENGINEERED FOR HARSH CLIMATES

The Hurricane ventilator has been engineered to withstand harsh climatic conditions around the globe.

In 2004, the Toyota Spare Parts Distribution facility, a Saud Bahwan owned property in Muscat, Oman installed 425 Hurricane H900 units. The climatic conditions include high average monthly maximum ambient temperatures of over 40°C.

WATER RESERVOIRS, HEAVY INDUSTRIAL AND CORROSIVE ENVIRONMENTS.

The HI ventilator is built for highly corrosive environments with fumes between pH 4-7. Applications include ceramic plants, power coating facilities and gritty environments.

The S2 is ideal for water reservoirs and other highly oxidative environments that require reliable ventilation to minimise condensation under metal roofs to prolong life of metal structure. Applications include pool complexes, water storage/tanks, caustic soda and sulphuric acid handling plants.

List of Hurricane case studies available at edmonds.com.au

Harvey Norman. Hurricane H900



Carlton United Breweries. Hurricane H900

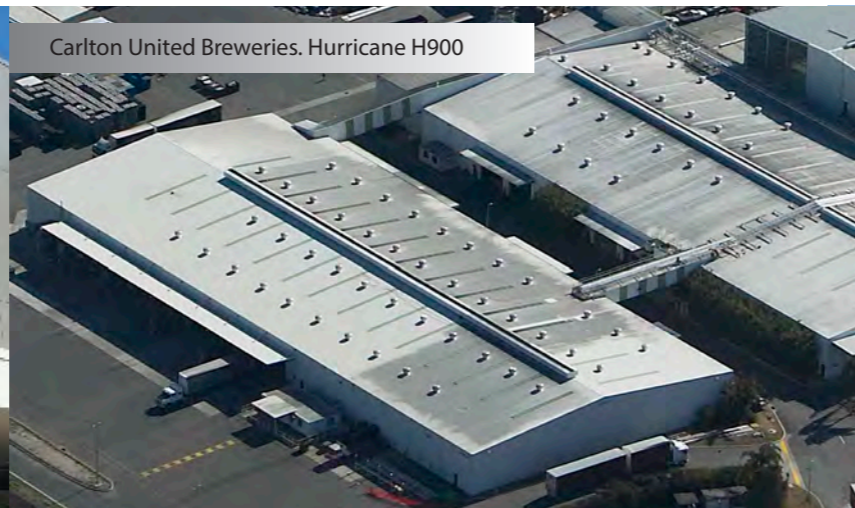

Water Reservoir Installation. Hurricane S2



Sydney Markets Banana Store. Hurricane FR



Hurricane was selected by the Toyota Spare Parts facility in Muscat Oman, for its ability to perform in high ambient conditions >40°C.

FIRE AND SMOKE RELEASE BUSHFIRE PRONE AREAS.

The FR ventilator provides both continuous ventilation and smoke release capability in the event of a fire (AS1668.1-1998 Section 4.8.1). Advantages versus traditional pneumatically released ventilators include both constant ventilation and responsive smoke release capacity which will be boosted by the buoyancy effect of rising hot air. Hurricane FR does not interfere with Early Suppression Fast Response sprinkler systems.

The BFR ventilator for Bushfire Prone Areas is designed to comply with the Deemed to Satisfy provisions of AS3959 Construction of Buildings in Bush Fire Prone areas.

RETAIL AND LIGHT COMMERCIAL

With heating and cooling system contributing up to 70% of a commercial building's electricity consumption¹, the Hurricane ventilator can provide significant savings by reducing the building's thermal load on the air conditioning system.

Applications include large retail spaces and warehouse stores.

CONDENSATION CONTROL

Poorly addressed condensation may result in equipment damage, plus additional repair and maintenance costs from wet ceilings, spoilt goods or disruption to production processes. One way to minimise condensation is to ventilate the building with ambient air. Applications include refrigerated warehouses, dry goods storage, meat and dairy processing plants and livestock sheds.

¹ Council of Australian Governments (2012) Guide to Best Practice Maintenance and Operation of HVAC Systems for Energy Efficiency, Department of Climate Change and Energy Efficiency

Model	H100	H150	H300	H400	H450	H500	H600	H700	H800	H900
Power Source	Wind & Stack Effect									
Dimensions on varipitch*										
Height Overall (mm)	313	363	480	564	634	700	724	796	848	936
Diameter Turbine (mm)	290	332	477	561	648	702	766	876	1003	1096
Flashing Length (mm)	430	430	600	750	750	750	1000	1000	1200	1200
Flashing Width (mm)	430	430	500	700	700	700	1000	1000	1200	1200
Throat area (m ²)	0.006	0.017	0.062	0.112	0.142	0.175	0.258	0.358	0.466	0.594
Mass* (kg)	1.80	2.40	4.90	6.30	8.1	9.2	11.8	15.8	20.6	24.1
Roof slope range - varipitch	0-45°	0-45°	0-45°	0-45°	0-45°	0-45°	0-45°	0-22.5°	0-22.5°	0-22.5°
Flow rate capacity #										
m ³ /hr	29	93	365	631	874	1,021	1,099	1,503	2,340	2,944
m ³ /s	0.01	0.03	0.10	0.18	0.24	0.28	0.31	0.42	0.65	0.82
l/hr	28,800	93,600	363,600	630,000	874,800	1,018,800	1,098,000	1,501,200	2,340,000	2,944,800
l/s	8	26	101	175	243	283	305	417	650	818
Material										
Turbine Top	Aluminium 5005									
Varipitch	Aluminium 5005									
Flashing	Aluminium 5005									
Finish	Mill / Powdercoat									
Accessories (optional)										
Electric Dampers	No	No	Yes	Yes	Yes	Yes	Yes	Yes	Yes	Yes
Manual dampers	No	No	Yes	Yes	Yes	Yes	Yes	Yes	Yes	Yes
Special bases - spigot slope	No	No	Yes	Yes	Yes	Yes	Yes	Yes	Yes	Yes
Special bases - spigot ridge	No	No	Yes	Yes	Yes	Yes	Yes	Yes	Yes	Yes
Special bases - square to round slope	No	No	Yes	Yes	Yes	Yes	Yes	Yes	Yes	Yes
Special bases - square to round ridge	No	No	Yes	Yes	Yes	Yes	Yes	Yes	Yes	Yes
Special bases - spigot curb mount	No	No	Yes	Yes	Yes	Yes	Yes	Yes	Yes	Yes
Special bases - square to round pyramid	No	No	Yes	Yes	Yes	Yes	Yes	Yes	Yes	Yes
Special bases - spigot pyramid	No	No	Yes	Yes	Yes	Yes	Yes	Yes	Yes	Yes
Special bases - EX base	No	No	Yes	Yes	Yes	Yes	Yes	Yes	Yes	Yes
Sparkguard	No	Yes	Yes	Yes	Yes	Yes	Yes	Yes	Yes	Yes
Special Variations										
FR : Fire-rated to meet AS 1668.1-1998 Section 4.8.1	No	No	No	No	No	No	No	No	No	Yes
BFR : Bush Fire Rated to meet AS3959	No	No	Yes	Yes	No	No	No	No	No	No
S2 : Corrosion Resistant	Yes	Yes	Yes	Yes	Yes	Yes	Yes	No	No	No
HI : Heavy Industrial	No	No	No	No	No	No	No	No	No	Yes
Australian designed and built	Yes	Yes	Yes	Yes	Yes	Yes	Yes	Yes	Yes	Yes
Manufactured in ISO 9001 facility	Yes	Yes	Yes	Yes	Yes	Yes	Yes	Yes	Yes	Yes
Designed and tested to AS4740	Yes	Yes	Yes	Yes	Yes	Yes	Yes	Yes	Yes	Yes

* Tolerance: Dimension +/- 5mm. Weight +/- 0.5kg

Flow rate figures are based on testing conducted by CSR Edmonds and in accordance to AS4740. Published flow rate results are optimal figures based on precision testing input and the other formulas are derived from fluid mechanics. Application results may vary due to external environmental factors, internal heat load, supply air capacity, construction materials and installation factors etc.

1300 858 674

www.edmonds.com.au

CSR Edmonds.

PO Box 231, Seven Hills, NSW 1730, Australia

Edmonds® and Hurricane® are registered trade marks of CSR Building Products Limited ABN 55008631356.

COLORBOND® is a registered trade mark of Bluescope Steel Limited.

The contents of this publication are the property of CSR Edmonds and may not be reproduced unless written permission is granted. Specifications and data are subject to change without notice. Every care has been taken to ensure the accuracy of the information contained within, but no liability will be accepted for any loss or damage whether direct, indirect or consequential due to the use of information contained herein.

Copyright 2015.



HURRICANE, VARIPITCH & FLASHING

DATE: 13 April 1999

REVISED: 4 February 2005

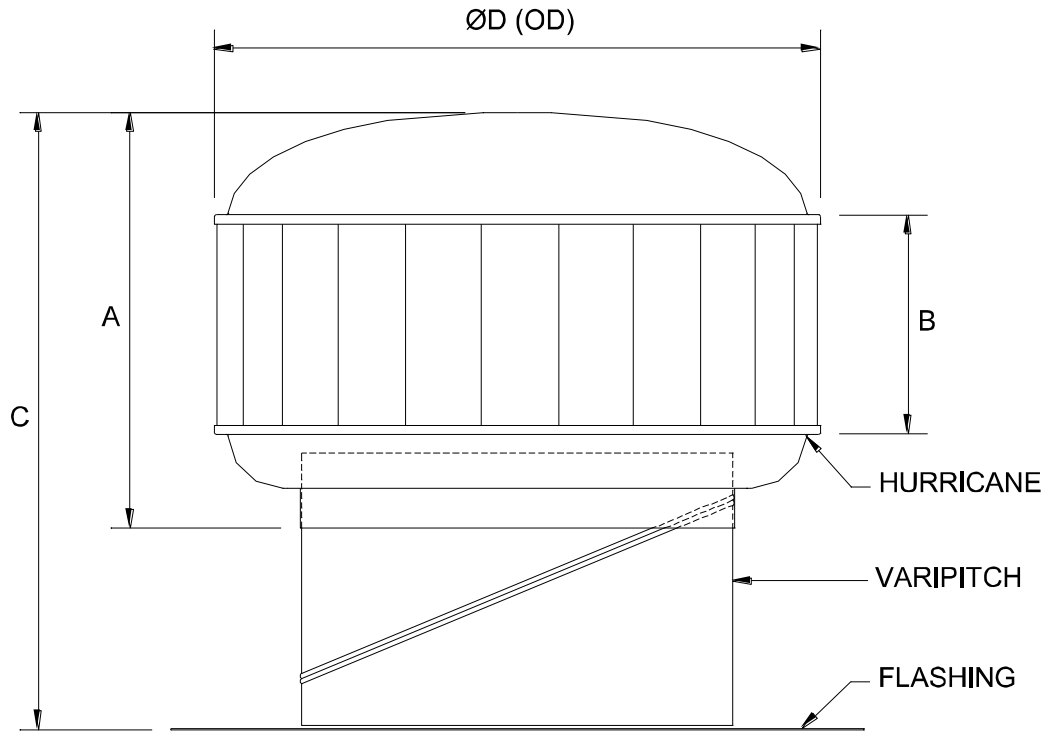

DIMENSIONS:

MODEL	A (mm)	B (mm)	C (mm)	ØD (mm)	Throat Area (m ²)	Weight (kg)
H100	253	100	313	290	0.009	1.8
H150	283	125	363	332	0.019	2.4
H300	364	175	480	477	0.075	4.9
H400	389	205	564	561	0.132	6.3
H450	419	230	634	648	0.168	8.1
H500	459	265	700	702	0.205	9.2
H600	484	275	724	766	0.285	11.8
H700	556	320	796	876	0.390	15.8
H800	580	345	848	1003	0.501	20.6
H900	643	400	936	1096	0.632	24.1

Tolerances: Size +/- 2mm
Weight +/- 0.1kg

NOTE

The Hurricane throat overlaps the Varipitch. The height listed above is with the maximum overlap (lowest overall height). Revolving the Varipitch to suit a roof slope also reduces its height.

HURRICANE VENTILATOR

DATE: 29 January 1999

REVISED: 4 February 2005

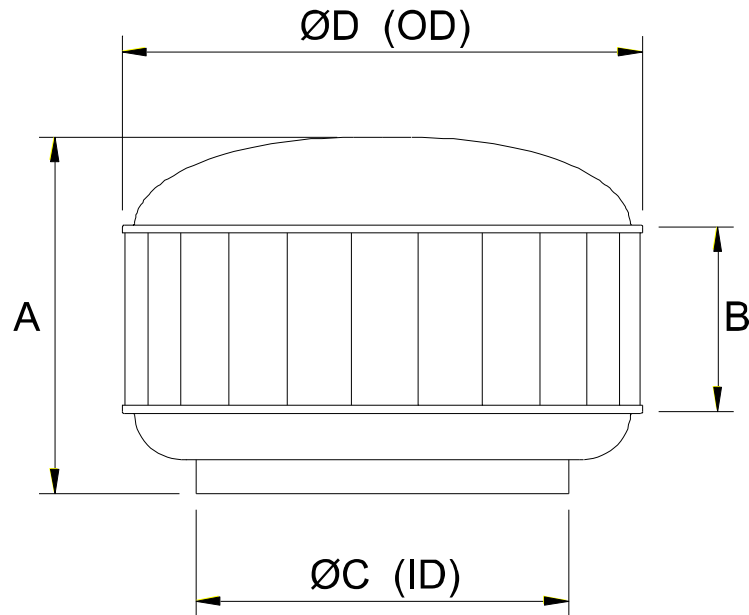

DIMENSIONS:

MODEL	A (mm)	B (mm)	ØC (mm)	ØD (mm)	Throat Area (m ²)	Weight (kg)
H100	253	100	107	290	0.0090	1.3
H150	283	125	155	332	0.0189	1.9
H300	364	175	308	477	0.0745	3.7
H400	389	205	410	561	0.1320	4.5
H450	419	230	462	648	0.1676	6.2
H500	459	265	511	702	0.2051	6.9
H600	484	275	602	766	0.2846	8.1
H700	556	320	705	876	0.3904	11.6
H800	580	345	799	1003	0.5014	14.9
H900	643	400	897	1096	0.6319	18.1

Tolerances: Size +/- 2mm
Weight +/- 0.1kg

SPECIFICATIONS:

MATERIAL:

Turbine & throat: Aluminium 5005 H34
 Shaft: Aluminium 2011 T3
 Dome & skirt: Aluminium 1200 O
 Brackets: Aluminium 6060 T591
 Spider (H600-H900 only): Zinc passivate plated mild steel
 Shaft (H900 only): 303 Stainless Steel
 Main bearing holder assembly: Glass Reinforced Nylon 6
 Main bearing: Double row ball bearing - BWF30-119Z
 Spider bearing (H600-H900 only): Single row ball bearing – AS204
WIND SPEED RATING: 205.2km/h (57m/s) – Performance level 1
 (As per AS 4740:2000 Natural ventilators-Classification and performance)

ROTATION BEARINGS:

WIND SPEED RATING:

HURRICANE VARIPITCH

DATE: 29 January 1999 REVISED: 4 February 2005

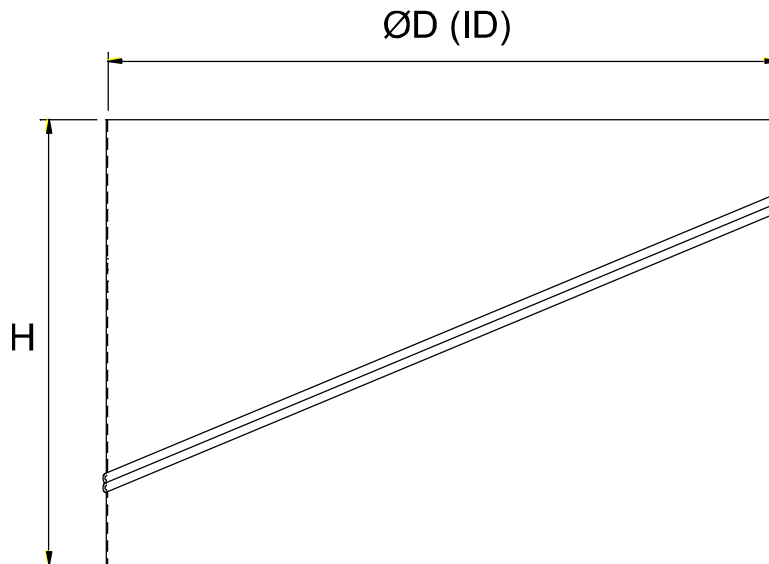

DIMENSIONS:

MODEL	H (mm)	ØD (mm)	Suit Roof Pitch	Weight (kg)
H100	110	103.5	0° - 45°	0.07
H150	130	152	0° - 45°	0.11
H300	190	305	0° - 45°	0.42
H400	250	405	0° - 45°	0.72
H450	290	457.5	0° - 45°	0.92
H500	315	506.5	0° - 45°	1.37
H600	340	597.5	0° - 45°	1.69
H700	340	699	0° - 22.5°	2.44
H800	365	795	0° - 22.5°	2.97
H900	390	895	0° - 22.5°	3.57

Tolerances: Size +/- 2mm
Weight +/- 0.02kg

NOTE

The Varipitch fits inside the throat of the Hurricane ventilator. Therefore the effective total height of the Varipitch is reduced by the overlap of the Hurricane throat. This overlap can vary from 50-110mm. Revolving the Varipitch to suit a roof slope also reduces its height.

SPECIFICATIONS:

MATERIAL: Aluminium 5005 H34

HURRICANE FLASHING

DATE: 29 January 1999 REVISED: 4 February 2005

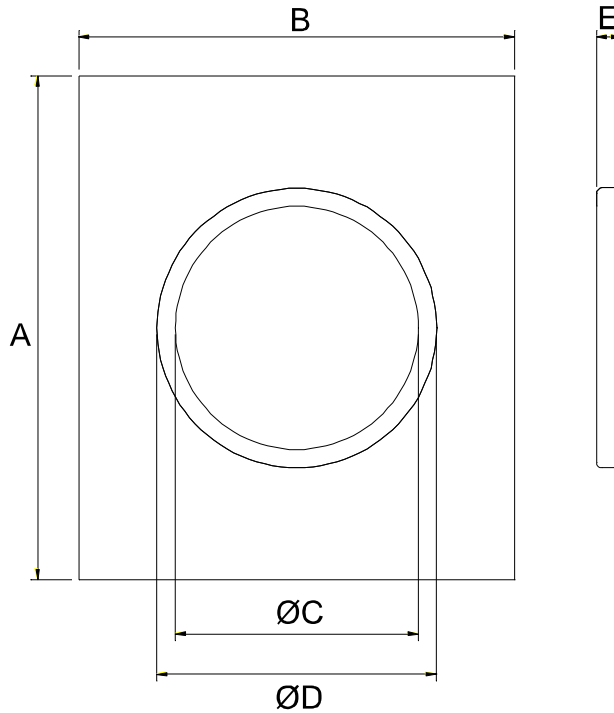

DIMENSIONS:

MODEL	A (mm)	B (mm)	ØC (mm)	ØD (mm)	E (mm)	Weight (kg)
H100	430	430	90	100	22	0.40
H150	430	430	127	147	22	0.35
H300	600	500	275	300	22	0.80
H400	750	700	378	403	24	1.10
H450	750	700	425	454	24	1.00
H500	750	700	472	504	24	0.93
H600	1000	1000	572	594	24	2.05
H700	1000	1000	675	697	24	1.76
H800	1200	1200	770	794	24	2.75
H900	1200	1200	870	893	24	2.45

Tolerances: Size +/- 1mm
Weight +/- 0.05kg

SPECIFICATIONS:

MATERIAL: H100 & H150: Aluminium 5005 O
H225 – H900: Aluminium 5005 H34

HURRICANE S2 VENTILATOR

DATE: 11 November 2002

REVISED: 15 March 2005

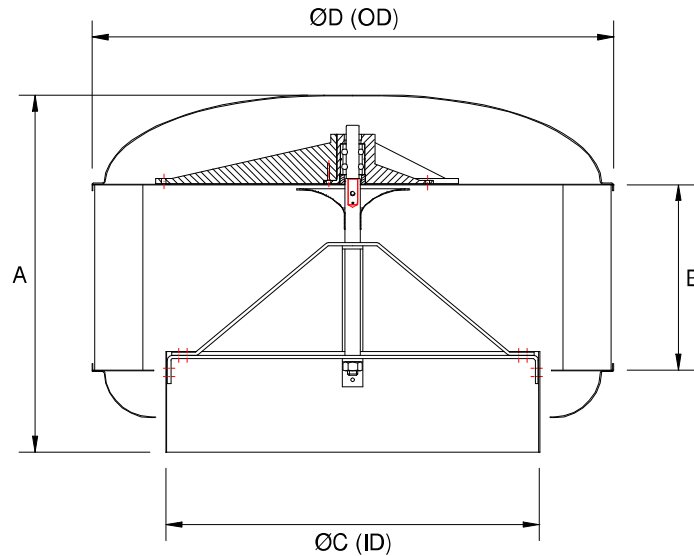

DIMENSIONS:

MODEL	A (mm)	B (mm)	ØC (mm)	ØD (mm)	Throat Area (m ²)	Weight (kg)
H100	253	100	107	290	0.0090	1.4
H150	283	125	155	332	0.0189	2.0
H300	384	175	308	477	0.0745	3.8
H400	389	205	410	561	0.1320	4.6
H450	443	230	462	648	0.1676	6.3
H500	459	265	511	702	0.2051	7.0
H600	484	275	602	766	0.2846	8.1

Tolerances: Size +/- 2mm
Weight +/- 0.1kg

SPECIFICATIONS:

MATERIAL:

Turbine & throat: Aluminium 5005 H34
Shaft: Aluminium 2011 T3
Dome & skirt: Aluminium 1200 H0
Deflector (Main Bearing shield): Aluminium 1200 H0
Brackets: Aluminium 6060 T591

ROTATION BEARINGS:

Main bearing: Double row ball bearing, Carbon Steel single shield

FINISH:

Powdercoated on inside and outside surfaces

WIND SPEED RATING:

205.2km/h (57m/s) – Performance level 1
(As per AS 4740:2000 Natural ventilators-Classification and performance)

HURRICANE HEAVY INDUSTRIAL VENTILATOR

DATE: 27 February 2003

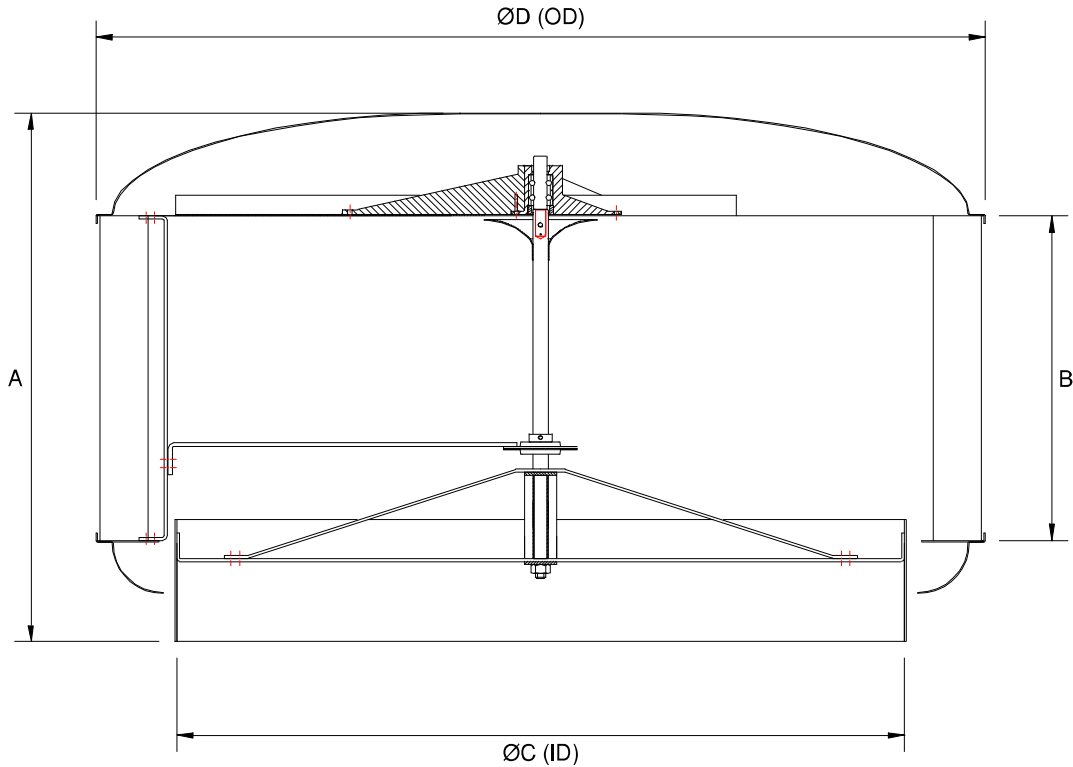

DIMENSIONS:

MODEL	A (mm)	B (mm)	ØC (mm)	ØD (mm)	Throat Area (m ²)	Weight (kg)
H900HI	643	400	897	1096	0.6319	18.1

Tolerances: Size +/- 2mm
Weight +/- 0.1kg

SPECIFICATIONS:

MATERIAL:

Turbine & throat: Aluminium 5005 H34
Shaft: 303 Stainless Steel
Dome & skirt: Aluminium 1200 H0
Deflector (Main Bearing shield): Aluminium 1200 H0
Brackets: Aluminium 6060 T591
Spider: 304 Stainless Steel

ROTATION BEARINGS:

Main bearing: Double row ball bearing, Carbon Steel single shield
Spider bearing: Single row ball bearing, Stainless Steel double shield

WIND SPEED RATING:

205.2km/h (57m/s) – Performance level 1
(As per AS 4740:2000 Natural ventilators-Classification and performance)

SAGINAW CONTROL & ENGINEERING

SCE-12R126

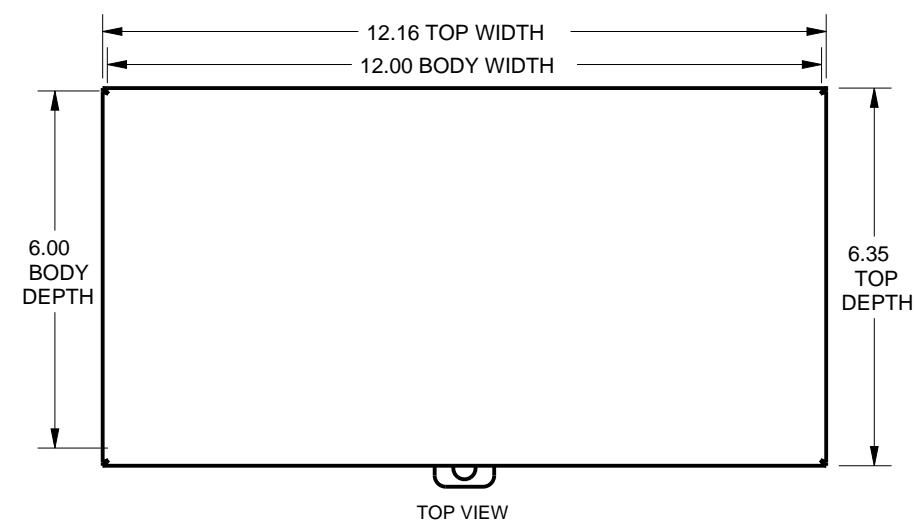

TOP VIEW

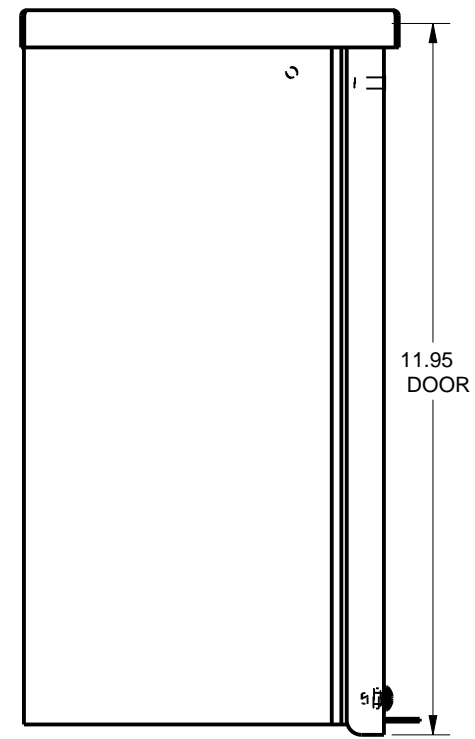

LEFT SIDE VIEW

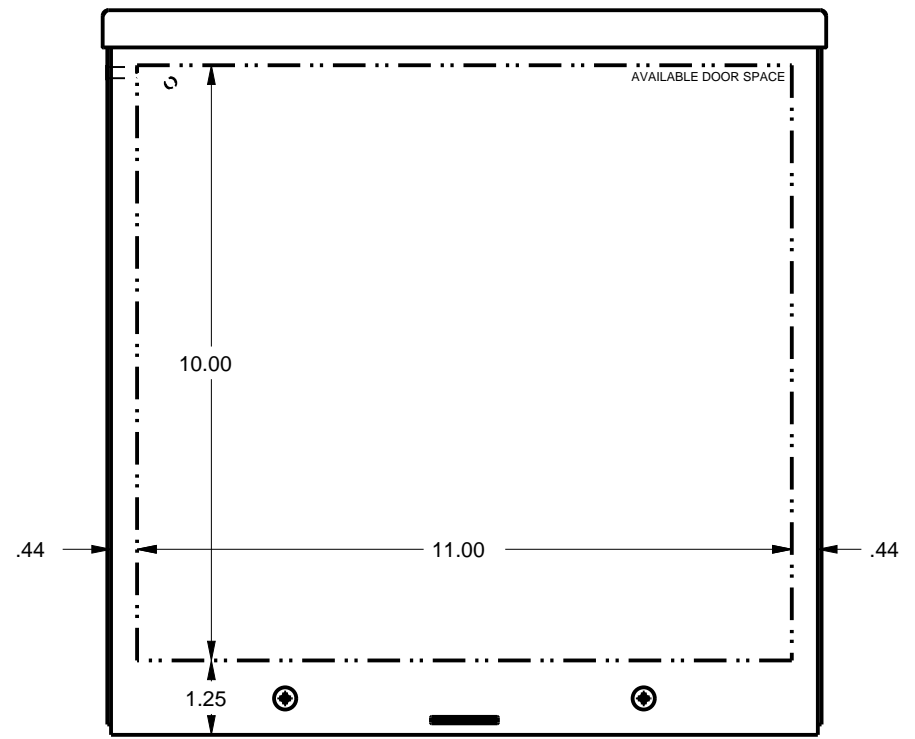

FRONT VIEW

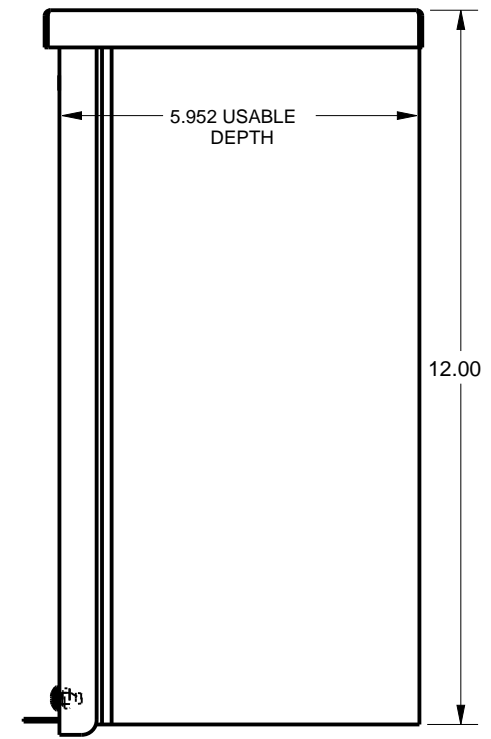

RIGHT SIDE VIEW

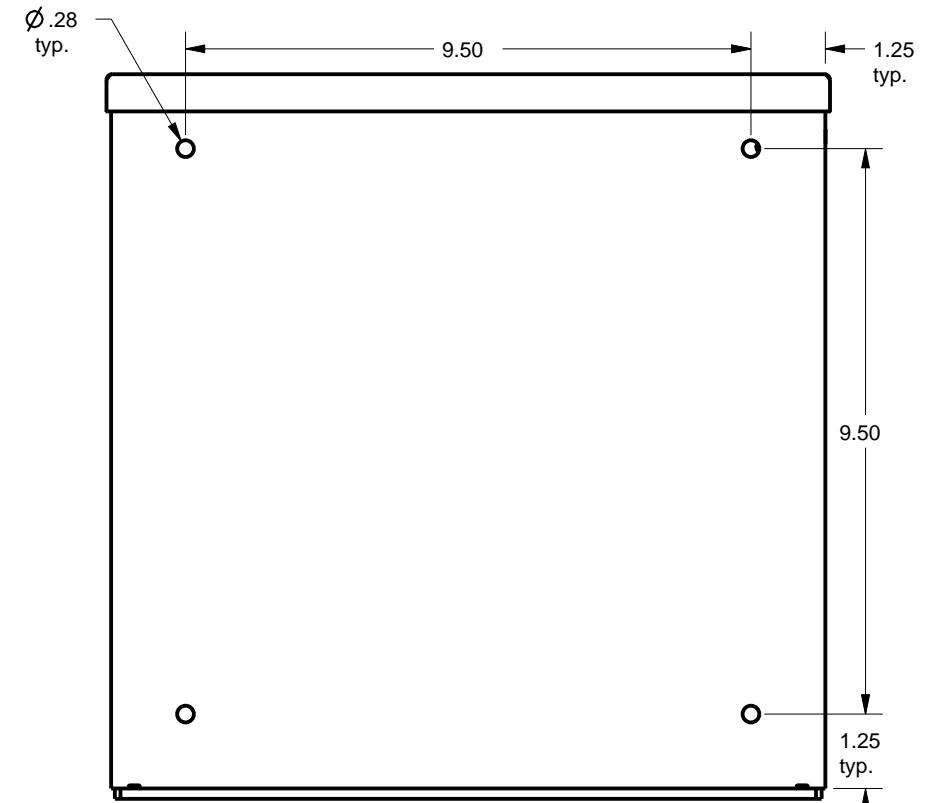

EXTERNAL REAR VIEW

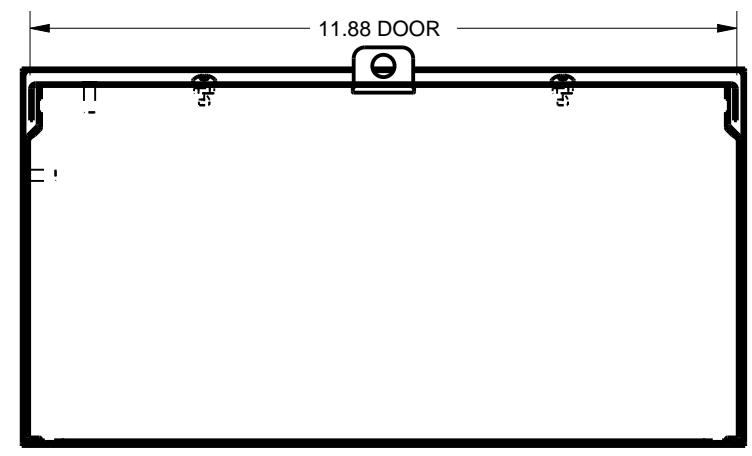

BOTTOM VIEW



Omni® Ball Valves

Standard Features (Sizes 3/8" – 3")

- Blocks in two directions
- Rugged structure
- Unibody construction
- Compact, low profile, short face-to-face dimensions
- PTFE seat backed by EPDM for low stem torque
- Rated for full vacuum service

Options

- Electrically actuated

Pressure vs. Temperature (PSI, WATER, NON-SHOCK)

NOMINAL SIZE		PVC		CPVC		
		30° F 120° F	30° F 120° F	121° F 140° F	141° F 175° F	176° F 195° F
INCHES	mm					
3/8-2	13-50	150	150	120	90	60
3	80	150	150	120	90	60

Sample Specification

All OMNI® ball valves size 3/8" - 3" shall be of one-piece compact design non-union type. All O-rings shall be EPDM with PTFE seats. Seats must have elastomeric backing cushions of the same material as the valve seals. PVC conforming to ASTM D1784 Cell Classification 12454-A, and CPVC conforming to ASTM D1784 Cell Classification 23567-A. Valve shall be rated 150 psi at 70°F, as manufactured by Asahi-America, Inc.

Dimensions (Sizes 3/8" – 3")

NOMINAL SIZE		SOCKET				THREADED								NOMINAL SIZE		SOCKET THR'D		NOMINAL SIZE		Cv
		ASTM SCH 40		L	d1	l	L	d	A					D	D1	h	INCHES	mm	INCHES	
d1	d2	l	d1							l	L	INCHES	mm							INCHES
3/8	13	0.687	0.671	0.59	3.35	3/8-18 NPT	0.59	3.35	0.51	2.36	1.22	1.38	1.65	3/8	13	0.22	3/8	13	7.7	
1/2	15	0.848	0.836	0.69	3.82	1/2-14 NPT	0.59	3.82	0.59	2.76	1.22	1.38	1.73	1/2	15	0.26	1/2	13	14	
3/4	20	1.058	1.046	0.72	4.02	3/4-14 NPT	0.67	4.06	0.79	3.15	1.46	2.17	2.17	3/4	20	0.55	3/4	20	29	
1	25	1.325	1.310	0.87	4.49	1-11 1/2 NPT	0.79	4.45	0.98	3.15	1.77	2.36	2.36	1	25	0.88	1	25	47	
1 1/4	32	1.670	1.655	0.94	5.00	1 1/4-11 1/2 NPT	0.87	5.00	1.22	3.74	2.13	2.76	2.76	1 1/4	32	1.21	1 1/4	30	72	
1 1/2	40	1.912	1.894	1.09	5.98	1 1/2-11 1/2 NPT	0.98	5.94	1.38	4.33	2.50	2.99	2.99	1 1/2	40	1.32	1 1/2	40	140	
2	50	2.387	2.369	1.16	6.93	2-11 1/2 NPT	1.10	6.97	1.77	4.33	3.01	3.31	3.31	2	50	2.20	2	50	185	
3	80	3.516	3.492	1.87	9.29	3-8 NPT	1.17	9.29	2.70	7.87	4.25	4.88	4.88	3	80	6.61	3	80	410	

Specifications

- Sizes:** 3/8" – 3"
Models: Socket and Threaded
Bodies: PVC, CPVC
Seats: PTFE backed with EPDM
Seals: EPDM

**Sizes 3/8" - 3" PVC/EPDM Models
NSF-61 Certified**

Omni® is a Trademark of Asahi/America, Inc.

Parts List (Sizes 3/8"– 3")

PARTS			
NO.	DESCRIPTION	PCS.	MATERIAL
1	Body	1	PVC, CPVC
2	Ball	1	PVC, CPVC
3	End Connector	1	PVC, CPVC
4	Stem	1	PVC, CPVC
5	Handle	1	ABS
6	Seat	2	PTFE
7	Cushion	2	EPDM, Others
8	O-Ring	1	EPDM, Others
1a	Ring*	2	304 Stainless Steel

*Used for CPVC body, threaded end, 1/2"– 1"

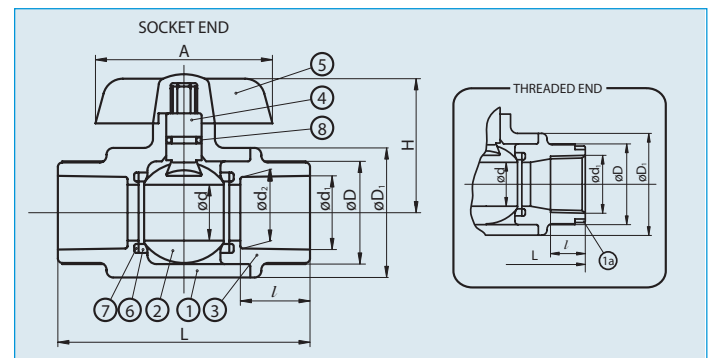

Weight (LBS.) Cv Values