



*2015 Interim Action Work Plan
NuStar Vancouver Facility
Vancouver, Washington*

Prepared for:
NuStar Terminals Services, Inc.

April 15, 2016
1126-18



**2015 Interim Action Work Plan
NuStar Vancouver Facility
Vancouver, Washington**

**Prepared for:
NuStar Terminals Services, Inc.**

**April 15, 2016
1126-18**



Amanda Spencer, R.G., P.E.
Principal



STEPHANIE L. BOSZE

Stephanie Bosze Salisbury, L.G.
Associate Geologist

Table of Contents

1.0 INTRODUCTION	1
1.1 Purpose	1
1.2 Work Plan Organization.....	2
1.3 Definition of Property, Site, and Facility.....	2
2.0 BACKGROUND	2
2.1 Property Location, Description, and History	2
2.2 Property Operations	3
2.3 Geology and Hydrogeology	3
2.4 Remedial Investigation	6
2.5 Interim Actions.....	8
2.6 Feasibility Study - Summary of Preferred Remedial Alternative.....	10
3.0 PROPOSED ENHANCED BIOREMEDIATION - DESIGN ANALYSIS	11
4.0 PROPOSED BASELINE SEDIMENT SAMPLING	14
4.1 Objectives.....	14
4.2 Understanding of Shoreline and River Bathymetry.....	15
4.3 Sampling Locations and Depths.....	15
4.4 Procedures	16
4.5 Chemical Analytes.....	17
5.0 PROPOSED BASELINE SURFACE WATER SAMPLING.....	17
6.0 SCHEDULE	18
7.0 REPORTING.....	19
8.0 REFERENCES	20

Figures

1	Property and Site Location Map
2	Property Plan
3	Geologic Cross-Section A-A'
4	Geologic Cross-Section B-B'
5	2008 and 2013 Isocontours of Tetrachloroethene (PCE) in Shallow Zone Groundwater
6	2008 and 2013 Isocontours of Trichloroethene (TCE) in Shallow Zone Groundwater
7	2008 and 2013 Isocontours of Cis-1,2, dichloroethene (cDCE) in Shallow Zone Groundwater
8	Extent of COPCs in Sediment and Historical Groundwater Concentrations
9	Extent of 2008 and 2011 Groundwater Interim Actions
10	Proposed 2015 Interim Action Injection Layout
11	Proposed Sediment and Surface Water Sampling Locations
12	Shoreline Cross-Section A-A'

Appendices

- A Historical Groundwater Potentiometric Maps
- B Bioremediation Design
- C POV Bathymetry and Seawall Structure Maps
- D Sampling and Analysis Plan

1.0 Introduction

This work plan presents the design for proposed additional interim action at the NuStar Terminals Services, Inc. (NuStar) bulk storage terminal at the Port of Vancouver Terminal No. 2, located at 2565 NW Harborside Drive in Vancouver, Washington (the Property). A Property location map is provided as Figure 1, and a Property plan is provided on Figure 2.

A Remedial Investigation (RI) and Feasibility Study (FS) were conducted to collect, develop, and evaluate information sufficient for selecting a cleanup action. An RI report was submitted to Ecology on August 14, 2013 (Apex, 2013), and was approved on November 6, 2013. A Draft FS was prepared jointly with the Port of Vancouver (POV); for the Cadet Manufacturing Company (Cadet) and Swan Manufacturing Company (SMC) sites, and was submitted to Ecology on January 13, 2015. Ecology posted the FS for public comment between January 22 and April 7, 2015. Ecology is currently reviewing the FS, including addressing comments received during the public comment period. In order to continue the ongoing remedial efforts at the Facility, NuStar has voluntarily proposed to implement portions of the FS, including the NuStar source area cleanup action, as an interim action. This interim action work plan is being prepared concurrently with Ecology's review of the FS in order to further progress the remedial efforts at the NuStar facility without incurring delay from the FS approval process.

NuStar has conducted three interim actions at the Property to-date. Between 2000 and 2005, NuStar operated a groundwater recirculation treatment system in conjunction with a soil vapor extraction (SVE) system. In 2008, food-grade oil was injected into the subsurface to promote the anaerobic degradation of volatile organic compounds (VOCs) in source area groundwater, and a new SVE system was constructed and operated to address vadose zone VOCs in the source area. In 2011, an additional round of enhanced bioremediation injections was implemented and the 2008 SVE system was expanded. Because of the historical success of enhanced bioremediation at the Facility, the current proposed interim action at the NuStar Facility will include bioremediation injections along the river shoreline portion of the facility and off-Property to the northwest of the NuStar terminal. The SVE will continue to be operated to address residual VOCs in vadose zone soils at the Facility. This work plan also proposes surface water and sediment sampling to be conducted in the Columbia River adjacent to the Property to establish baseline surface water and sediment concentrations prior to the interim groundwater cleanup action.

1.1 Purpose

The purpose of this interim action work plan is to define the scope and schedule for implementation of an interim action at the Property.

1.2 Work Plan Organization

Background information and a summary of the RI and FS and previous interim actions are summarized in Section 2. The design of the proposed interim action is presented in Section 3 and baseline sediment and surface water sampling are summarized in Section 4. A project schedule is presented in Section 6. Supporting information, including detailed design drawings for the interim actions, are included in appendices.

1.3 Definition of Property, Site, and Facility

As used in this report, the Property refers to the NuStar 2006 leasehold area. The 2006 leasehold boundary is shown on Figure 2. Changes in business lines have led to revisions in the NuStar leasehold. The 2006 leasehold boundary was selected as it is representative of the Property throughout much of the terminal operational period.

The Site is defined consistent with the Model Toxics Control Act (MTCA) and the Agreed Order (AO) to include the area where a hazardous substance from a release at the Property has “come to be located.” Therefore, the boundaries of the Site are determined by the results of the RI (Apex, 2013). The AO states that the Site constitutes a Facility under RCW 70.105D.020(4). Consistent with MTCA, the term “Facility” is used interchangeably with the term “Site” in this report.

2.0 Background

2.1 Property Location, Description, and History

Location. The Property is located at the POV Terminal No. 2 in Vancouver, Washington (as shown on Figure 1). The Property address is 2565 NW Harborside Drive, Port of Vancouver, Vancouver, Washington 98660 (Latitude: N45° 38.26', Longitude: W122° 42.20'). The Property is owned by the POV and leased by NuStar.

Physical Features. Figure 2 is a Property Plan. Until 2006, NuStar consisted of a roughly rectangular area with nominal dimensions of 600 by 1,300 feet; in 2006, the leasehold was expanded to include additional area to the north (see Figure 2). The total area of the facility is approximately 19 acres, which includes the leasehold extent up to 2006 and the additional leased area after 2006. The NuStar facility is on the north shore of the Columbia River. Land on all other sides is industrial property also owned by the POV. The NuStar facility is located on Clark County Tax Lot (TL) Nos.: 151979-000, 502010-002, 502010-000, and a portion of 502020-000, as well as a portion of the Washington Department of Natural Resources tideland area managed by the POV.

The Property includes five buildings (Warehouses 9, 13, 14, 15, and 17), a loading dock, three aboveground storage tank (AST) farms, two tank truck loading/unloading racks, a rail tank car loading/unloading area, marine vessel dock and piping, and an office. The ground surface is nearly flat at an elevation typically between 32 and 34 feet above mean sea level (MSL). The majority of product piping is aboveground, except for the buried pipeline that extends from the marine vessel dock to the north to the NuStar Vancouver Annex terminal located approximately 1.7 miles to the north/northeast of the property.

The Property includes extensive underground utilities. Utilities are within about 10 feet of the ground surface, above the groundwater table.

2.2 Property Operations

In general, the NuStar terminal was developed to receive, store, and handle bulk fuel and chemicals. Typically, these chemicals were not owned by the terminal operator. Rather, the terminal operator entered into agreements as a wholesale distributor to handle chemicals for owners. The terminal was owned/operated by GATX from the early 1960s through 1998 (GATX has since been acquired by Kinder Morgan). The terminal was acquired in 1998 by Support Terminals (ST) Services, a subsidiary of Kaneb Pipeline Partners L.P. (Kaneb). Kaneb was acquired in 2005 by Valero L.P. Valero L.P. changed its name to NuStar Energy L.P. in 2007 and changed the name of ST Services to NuStar Terminals Services, Inc. The terminal property is currently leased and operated by NuStar Terminals Services, Inc.

Although a variety of products have been handled at the NuStar facility over the years, the historical sampling has identified chlorinated solvents as the chemicals of interest, particularly tetrachloroethene (PCE), trichloroethene (TCE), methylene chloride (MC) and 1,1,1-trichloroethane (1,1,1-TCA). Chlorinated solvents were direct loaded from rail trucks to tank trucks through 1981; after 1981, the solvents were transferred from rail trucks to ASTs, then from ASTs to tank trucks (Apex, 2013). Historical company records indicate that handling of chlorinated solvents ended by 1994 and may have ended as early as 1994, but that end date is uncertain.

Currently, sodium hydroxide is received via water vessel and transported out by rail and truck. Jet A fuel is received via water vessel and transported out via barge. Calcium chloride is received via rail and transported out via truck, and dry bulk materials are received via water vessel and transported out via truck.

2.3 Geology and Hydrogeology

This section presents the understanding of the geology and hydrogeology at the Property. Additional information on the geology and hydrogeology at the NuStar Property are discussed in the RI (Apex, 2013).

2.3.1 Geology

Regional Geology. The regional geology is summarized below based on SECOR (2001) and AMEC (2005). The vicinity of the Site is dominated by two primary units: the Unconsolidated Sedimentary Aquifer (USA) and the Troutdale Formation.

The USA is the upper unit. The upper portion of the USA contains unconsolidated silt and sand. The lower portion generally consists of sand or sand and gravel. The Troutdale Formation underlies the USA and can be in excess of 1,000 feet thick. There is an unconformity in the Troutdale Formation, representing exposure and a period of erosion prior to the deposition of unconsolidated sediments through catastrophic flooding events. These catastrophic floods were caused by periodic failures of ice dams, releasing large volumes of lake waters and sediments from Idaho and Montana during the Pleistocene Age. The resulting Pleistocene flood deposits are made up of cemented sandy gravels and semi-consolidated sands, silts, and clays.

Local Geology. The vicinity of the Site is dominated by two primary units: the USA, and the Troutdale Formation. Figures 3 and 4 present geologic cross-sections through the Site. The upper part of the USA that underlies the Facility consists of fine to coarse sand with variable layers of silt or silty sand. The upper sandy zone extends from the ground surface to a depth of up to 50 feet beneath the western and central portions of the Facility and extending south to the Columbia River. Within the upper USA, a silt layer is present on the north and east parts of the Facility. At the northern Facility boundary, the silt is encountered at depths as shallow as 9 to 10 feet bgs and extends to depths of approximately 40 feet bgs. This layer is continuous along the north, west, and east of the Facility, forming a low-permeability ridge at the Facility boundary.

A silty gravel layer underlies the sandy/silty layers of the upper USA beneath the Facility. The silty gravel grades into the coarse sand and/or gravel of the lower portion of the USA. The depth to the top of the silty gravel varies from 39 (north) to 50 (south) feet bgs beneath the Facility.

2.3.2 Hydrogeology

This section presents the understanding of the regional and local hydrogeology.

Regional Hydrogeology. The regional aquifers follow the regional geology discussed above. The regional hydrogeology summarized below is based on SECOR (2001) and AMEC (2005).

The USA is unconfined and receives recharge directly from the land surface and/or surface water features. It is a productive aquifer with high well yields (several thousand gallons per minute [gpm] without significant drawdown). Based on numerous studies conducted in the POV area, the following aquifer terminology has been adopted:

-
- Shallow Zone – The Shallow Zone corresponds to first encountered groundwater, generally the upper 20 to 30 feet of the saturated zone. At the Facility, depth to first encountered groundwater is general 21 to 33 feet below grade (elevation of 5 to 12 feet). The bottom of the Shallow Zone is about elevation -10 to -20 feet, or a depth of about 40 to 50 feet.
 - Intermediate Zone – The Intermediate Zone generally corresponds to the middle of the USA. This zone is most directly influenced by pumping wells in the USA. The Intermediate Zone lies between approximate elevations -15 and -100 feet. At the Facility, the Intermediate Zone is between depths of about 55 and 130 feet.
 - Deep Zone – The Deep Zone includes the Troutdale Formation and, in some areas, the lower part of the USA. It generally corresponds to portions of the aquifers that are less influenced by groundwater pumping and more by regional influences.

Local Hydrogeology. Figures 3 and 4 show interpretations of the hydrogeologic units at the Site. Beneath most of the Property, the Shallow Zone lies within the sand layer overlying the silty gravel. Along the northern Property boundary and continuing to the north, the Shallow Zone lies entirely within the silt layer. As a result, the silt layer forms a low-permeability zone that greatly impedes hydrogeologic communication between the Shallow and Intermediate Zones on the Property, and effectively isolates the Shallow Zone on-Property from the Shallow Zone off-Property. The presence of silt in the Shallow Zone, particularly at the lower contact of the groundwater zone, results in a Shallow Zone that has an overall lower permeability than the Intermediate Zone.

A groundwater divide is present in the central portion of the Property within the Shallow Zone, generally corresponding to the southern edge of the “silt ridge” at the Property. Groundwater south of the groundwater divide is more sensitive to tidal variations. Shallow groundwater to the north of the divide appears to be less tidally influenced and generally flows away from the river. Historical potentiometric maps, depicting a fairly consistent northwest/southeast trending groundwater divide in Shallow Zone groundwater, are provided in Appendix A.

The lower reaches of the Columbia River – where the Site is located – are subject to tidal variations as well as seasonal and stage variations due to precipitation and regulation of river flow by dams.

Groundwater flow in the Intermediate Zone at the Facility is variable and was evaluated within a regional context in 2011 (2011 Groundwater Flow Evaluation Report; Ash Creek, 2012a). Several factors influence groundwater flow in the Intermediate Zone in the vicinity of the Facility, including pumping from municipal supply wells and industrial production wells as well as changes in Columbia River water levels. The 2011 annualized groundwater gradient further from the river (as measured between POV wells MW-32i and MW-33i) was essentially flat with a gradient of 0.000018 ft/ft to the northeast (Ash Creek, 2012a).

2.4 Remedial Investigation

Since 1980, numerous investigations have been conducted by various parties. These investigations identified the presence of chlorinated solvents and associated breakdown products, primarily PCE, TCE, and cis-1,2-dichloroethene (cDCE) in soil, groundwater, and soil vapor. Investigation activities were completed between 1980 and 2012. Together, these activities comprise the RI (Apex, 2013) summarized in this section.

Surface Water. The Columbia River, adjacent and to the southwest of the Site, serves as an active channel for large commercial ships. Throughout its course, the river is used by many communities (not Vancouver) as a source of drinking water. However, within at least several miles of the Site, the river is not used for drinking water purposes and is not likely to be used within the foreseeable future. In 2006, the U.S. Environmental Protection Agency (EPA) designated the Troutdale aquifer beneath Clark County as a Sole Source Aquifer. In the designation, published in the Federal Register on September 6, 2006 (Vol. 71, No. 172), the EPA indicated that 99.4 percent of Clark county's population (approximately 450,000 people; U.S. Census Bureau, 2014) used the aquifer as their source of drinking water. Further, the EPA indicated that it was not economically feasible to replace groundwater with surface water. Along the course of the river, water is also used for stock, agriculture, and industrial water supplies.

Anadromous and resident fish species use parts of the river during various stages in their life cycles, including spawning, rearing, and migration. The Columbia River is also used for fishing for sport and consumption, recreational boating, general recreation, and aesthetic value. A number of local American Indian tribes have fishing rights on the Columbia River.

Chemicals of Potential Concern. A screening of chemical data identified the chemicals of potential concern (COPCs) in soil and groundwater at the NuStar site to be chlorinated solvents and associated degradation products. Three COPCs (PCE, TCE, and vinyl chloride [VC]) account for greater than 95.9 percent of potential risk based on comparison to screening levels (Apex 2013a). Although cis-1,2 DCE is not a risk driver, it is the daughter product of TCE and breaks down to form VC. Therefore, these four compounds represent the primary COPCs. VC is not widely detected across the Site; therefore, PCE, TCE, and cis-1,2-DCE were used in the RI as indicator compounds for assessing chemical fate and extent.

Primary Source Area. Based on a review of historical Facility use information, three potential source areas were present at the Property (Ash Creek, 2006a). Targeted sampling was performed in and around these three areas, and the results demonstrated that the primary source area at the Property is the historical direct load area near the northwest corner of Warehouse 13 (Figure 2).

Extent of COPCs in Soil. The HVOCs in vadose zone soil are predominantly PCE, with lesser concentrations of TCE and cis-1,2-DCE. As summarized in the RI (Apex, 2013), the extent of PCE in soil is defined by chemical analytical results up to the river and is confined to the NuStar facility. A soil

investigation was conducted in 2010 to evaluate the overall performance of the 2008 soil interim action (see Section 2.5.2). The 2010 investigation supported that the majority of the VOC mass had been removed within the soil vapor extraction (SVE) area of influence between 2008 and 2010 (Ash Creek, 2011), and the SVE system was expanded in 2011 to cover a larger area of influence. As of December 2014, SVE has removed approximately 5,230 pounds of VOC mass from the source area. As the focus of this interim action is in groundwater and saturated soils, and the SVE cleanup action is ongoing, the soil cleanup effort will not be discussed further in this interim action work plan.

Extent of COPCs in Shallow Zone Groundwater. Isocontours of PCE, TCE, and cis-1,2-DCE in shallow zone groundwater in March 2008 and March 2013 are provided in Figures 5 through 7. As can be seen from the figures, HVOCs in the shallow zone on the northern portion of the leasehold have been and continue to be generally confined to the NuStar facility. There is a small, localized off-property source to the northwest of the NuStar facility; the extent of shallow groundwater impacted by this off-property source is limited to an area of approximately 100 by 300 feet and does not extend to the Columbia River. It has not impacted the underlying intermediate zone. At the southern portion of the NuStar facility, groundwater flow is towards the river where it is understood to interact with river sediments. As can also be seen by the figures, there has been a significant reduction in shallow zone VOC concentrations since implementation of the 2008 and 2011 groundwater interim actions.

The source area at the NuStar facility is confined to the shallow zone groundwater. Halogenated volatile organic compound (HVOC) concentrations are one to two orders of magnitude less in the intermediate zone groundwater relative to shallow zone groundwater due to the presence of the silty gravel layer beneath the shallow zone in the central and southern portions of the property and the silt ridge at the northern property boundary. The intermediate zone groundwater at the NuStar facility extends beyond the property and is considered part of the project area dispersed plume, as described in the draft FS (Parametrix and Apex, 2015).

Extent of COPCs in Sediments. Figure 8 shows the extent of COPCs in river sediments adjacent to the NuStar Facility. Sediment data are presented for the uppermost samples collected (typically the mudline and first subsurface sample) as this definition of “sediment” is consistent with the Sediment Management Standards (SMS) Rule (Ecology, 2013) and is representative of the portion of the river channel where “humans or biota may be exposed”. A conceptual site model for the distribution of VOCs in sediments was initially presented to Ecology in the RI (Apex, 2013). The magnitude and distribution of VOCs in sediments suggest that river sediments were directly impacted from the migration of upland groundwater containing source-level VOC concentrations. As evaluated in the NuStar risk assessment (Ash Creek, 2008) and in the updated NuStar risk assessment (Apex, 2013), VOC exposure point concentrations (EPCs) in upland groundwater were used to estimate potential impacts to river sediments using the three phase partitioning model in WAC 173-340-747(4) and (5). The estimated VOC concentrations in sediment from groundwater

containing VOCs were consistent with the empirical sediment data collected during investigations in 2011 and 2012.

VOCs detected one or more times in sediment were considered to be COI. The maximum detected concentration was compared to ecological effects-based screening level concentrations in the NuStar RI. COI that exceeded screening levels included PCE, TCE, cis-1,2-DCE, 1,1-Dichloroethene, and Vinyl Chloride. Because each of the sediment COI were included in the list of COPCs for groundwater, and the sediments are understood to be impacted by groundwater, the full list of COI were retained as COPCs in sediments. Four indicator compounds were used to evaluate the extent of VOCs in sediment, and include: PCE, TCE, cis-1-2, DCE, and vinyl chloride.

As shown on Figure 8, the extent of COPC concentrations above risk-based screening levels is limited to a rectangular area extending approximately 600 feet along the southern Property boundary and approximately 100 feet riverward from the boundary. Similar to the one to two order magnitude decrease in groundwater concentrations between the Shallow and Intermediate Zone groundwater, VOC concentrations in sediments in contact with Intermediate Zone groundwater are generally a half to one order of magnitude less than in sediments in contact with Shallow Zone groundwater. The areas of highest impact (locations "C", "3", and "D", Figure 8) are located directly downgradient from the primary source area at the Property. The extent of VOCs in sediment to the west/northwest and east/southeast were defined by previous sediment investigations and generally correlate with the northwest-southeast boundaries of the Shallow Zone groundwater plume at the Site.

2.5 Interim Actions

The results of the RI indicate that the primary release area is located between Warehouses 13 and 15, beneath the rail siding north of these warehouses, and extending south toward the sea wall. Rail car off-loading historically occurred at the north end of this area. Three interim actions have been conducted in this area. A summary of each is provided below.

2.5.1 Interim Action – 2000 through 2005

Pursuant to a 1998 AO between Ecology and Support Terminals Services, Inc. (a.k.a. ST Services), an interim remedial action system was installed at the Property in 2000. Detailed work scopes, procedures, and methods for these activities were presented in the *Final Interim Action Pilot Study Work Plan*, (SECOR, 1999b), *Response to Ecology's Comments Letter* (SECOR, 1999c), and the *Final Interim Action Work Plan* (SECOR, 2000a). The primary objective of the interim action was to VOC concentrations in soil and groundwater within the interim action areas. The interim action consisted of two components: (1) a re-circulating system to treat groundwater; and (2) vapor extraction to treat soil. The groundwater treatment system was designed to treat shallow groundwater (less than 45 feet deep) with PCE concentrations in excess of 1 milligram per liter (mg/L). The interim action system extracted groundwater from wells installed

near the river (EX-3 through EX-5), treated the extracted water with potassium permanganate, and then filtered and pumped the water into a series of injection wells along the railroad tracks (IN-1 through IN-9). For soil, an SVE system withdrew soil vapors from wells IW-1, IN-2, IN-3, IN-4, EX-1, EX-3, EX-4, and EX-5. A detailed description of the installation of the interim action system is provided in the *Final Remedial Investigation Report* (SECOR, 2001). Interim remedial action continued through 2005. The interim action successfully removed HVOC mass at the Property (based on the drop in concentration of HVOCs in some wells), but overall the system was not efficient at addressing the release area.

2.5.2 Interim Action – 2008: Combined Enhanced Bioremediation and Soil Vapor Extraction

In 2008, an interim action was implemented to address the release area at the NuStar facility while the RI, risk assessment (RA), and FS were being completed. An analysis of interim action alternatives was completed to select the appropriate action (Ash Creek 2006). Based on the results of the interim action analysis, enhanced bioremediation and SVE was selected and described in detail in a design report (Ash Creek 2007). Ecology accepted the design report on January 10, 2008, contingent upon a response to comments. Ash Creek submitted a comment response letter to Ecology on May 7, 2008 (Ash Creek 2008c). The interim action was initiated in April 2008 and consisted of installation of temporary injection points, injection of a bioremediation substrate, installation of SVE wells and associated trenching/pipe, installation and startup of the SVE system, and routine operations, maintenance and monitoring of the SVE system. The bio-injection substrate, CAP18-ME, was derived from food-grade vegetable oil components (triacylglycerols and esterified fatty acids) and provided a carbon source for the anaerobic reductive dechlorination treatment pathway. The bioremediation substrate was injected into shallow zone groundwater at 38 locations within the source area, as shown on Figure 9. The SVE system consisted of 18 soil vapor extraction wells and operated nearly continuously (with the exception of minor shutdowns for maintenance or monitoring purposes) until the system was expanded and reconfigured in August 2011.

2.5.3 Interim Action – 2011 Additional Interim Action (Enhanced Bioremediation and Expanded SVE)

A soil and groundwater investigation was conducted in the source area in 2010 to assess the progress of the 2008 interim action. The investigation confirmed the success of the 2008 interim action and provided the data needed to develop a work scope for continued interim action. The 2011 Interim Action Work Plan (IA Work Plan) was submitted to Ecology on November 30, 2010 detailing the proposed additional 2011 interim action (Ash Creek 2011; Appendix O). Ecology approved the IA Work Plan in an email on March 30, 2011 and the expanded (2011) interim action was implemented from July through October 2011. A 2011 interim action included additional enhanced bioremediation injections and an expansion of the 2008 SVE system. The additional interim action doubled the areal extent of the 2008 SVE system and included four times the number of bio-substrate injections points across an area that was four times larger than the 2008 bioremediation area. During the 2011 interim action, the selected bio-injection substrate (EOS®

electron donor, manufactured by EOS Remediation, Inc., of Raleigh, North Carolina) was injected at 155 locations within the primary release (source) area. The SVE system was expanded to include an additional 34 extraction wells and the installation of a second blower. Approximately five months after the interim action was implemented, the 2011 Interim Action Evaluation Report was submitted to Ecology, summarizing the expansion of the SVE system and startup activities, the enhanced bioremediation injections, and groundwater and SVE effluent monitoring results during the first five months of operation (Ash Creek 2012).

Success of Interim Actions. Figure 9 shows the extent of the 2008 and 2011 bioremediation remedial actions. Concentrations of COCs have decreased by up to four orders of magnitude in the primary release area. For example, monitoring well MW-7 is located in the primary source area and historically exhibited PCE concentrations as high as 73,000 micrograms per liter ($\mu\text{g/L}$). PCE concentrations in well MW-7 are currently below the drinking water based cleanup level of 4 $\mu\text{g/L}$. Similarly, monitoring wells MW-12, MGMS2-40, EX, and MP-1, also located in the 2008 and/or 2011 interim action injection areas, have exhibited reductions in total VOC concentrations ranging from 80 percent in well MP-1 to over 99 percent in wells EX, and MGMS2-40 (Apex, 2015). The data from the 2008 and 2011 interim actions confirm that enhanced bioremediation is a successful technology for addressing HVOC concentrations in groundwater at the Facility.

2.6 Feasibility Study - Summary of Preferred Remedial Alternative

As discussed in Section 1.0, a joint FS was prepared by the POV and NuStar for the Swan, Cadet and NuStar sites (Parametrix and Apex, 2015). Based on the results of the FS, the recommended cleanup action alternative for groundwater at the site is additional enhanced bioremediation combined with monitored natural attenuation (MNA). Enhanced bioremediation will be used to treat groundwater in the remaining elevated groundwater concentrations located adjacent to the river. As discussed in Section 2.5, bioremediation injections have already been demonstrated at the Site to reduce VOC concentrations to below laboratory reporting limits. MNA would be used to address residual concentrations of COC in peripheral areas of the groundwater plume.

As summarized in RI (Apex 2013a) and in Appendix G of the Draft FS (Parametrix and NuStar, 2015), the magnitude and distribution of sediment impacts suggested that river sediments were directly impacted from the migration of upland impacted groundwater. Based on our understanding of the source of sediment impacts, upland source control was the preferred remedial alternative for sediments presented in the FS. For this alternative, active treatment of the groundwater source would be used to eliminate the ongoing source of HVOCs to sediment via the groundwater pathway. Thereafter, monitored natural recovery (MNR) would result in reduction of sediment concentrations to below cleanup levels.

3.0 Proposed Enhanced Bioremediation – Design Analysis

The FS (Parametrix and Apex, 2015) identified *in situ* enhanced bioremediation as the technology to address volatile organics in the groundwater and saturated soil of the Shallow Zone treatment area (from the top of the groundwater table to a nominal depth of 45 to 55 feet). As discussed in Section 2.5, the 2008 and 2011 bioremediation injections significantly reduced VOC concentrations in the footprint of the injection area. Therefore, additional injections are proposed for those areas outside of the primary source area where VOC concentrations are still elevated in groundwater, as shown on Figure 10. The following sections summarize the conditions within the expanded interim action area to support the injection strategy, and provide a detailed description of the interim action implementation.

Saturated Soil Profile. Based on previous investigation and bioinjection work, the saturated zone soil in the expanded interim action area is generally characterized by a medium sand (with occasional lenses of silty sand or silt) that extends from the top of the water table (a nominal depth of 25 feet) to the bottom of the shallow aquifer. Figure 3 shows a cross section through the vicinity of the treatment area. At approximately 40 to 50 feet bgs, a layer of silt and silty gravel separate the overlying medium sand (Shallow Zone) from an underlying gravel unit (Intermediate Zone). A review of boring logs from wells located near the seawall indicate that the silty zone may be encountered anywhere between 35 and 55 feet bgs, but typically between 40 to 50 feet bgs.

Chemical Profile. Within the proposed (2016) interim action area on the NuStar property, PCE concentrations in groundwater range from 0.00084 mg/L to 8.1 mg/L and TCE concentrations in groundwater range from 0.0028 mg/L to 2.2 mg/L during the June 2015 groundwater monitoring event. In the proposed off-Property injection area to the northwest of the NuStar terminal, PCE ranged from 205 to 250 µg/L and TCE ranged from 250 to 790 µg/L during the June 2015 monitoring event. Historical investigations indicate that the relatively highest concentrations of PCE and TCE in the saturated zone were found at depths of between 35 and 45 feet bgs (Ash Creek, 2006).

Selected Injection Substrate and Quantity. The selected injection substrate for the interim action expansion is an emulsified oil substrate manufactured by EOS Remediation, Inc., of Raleigh, North Carolina. The EOS® electron donor consists of a blend of fast- and slow-release electron donors in a micro-emulsion form with uniform droplets significantly smaller than soil pore spaces. EOS® is a non-toxic emulsified soybean oil product that includes easily biodegradable substrate (e.g., sodium lactate) and slowly degradable substrates (e.g., edible oil). The sodium lactate in the solution stimulates microbial growth and rapidly produces anaerobic conditions in the subsurface. After the lactate has been consumed, the less-soluble vegetable oil portion of the product is retained on the soil surfaces and pore spaces. The vegetable oil slowly ferments to release volatile fatty acids and molecular hydrogen, which support the anaerobic microbial community. The EOS® injection substrate will not float on the water table and has been engineered to prevent agglomeration (flocculation) of the small oil droplets. This facilitates spreading the

emulsion during injection to the designed distance in the subsurface while sorbing substrate to soil surfaces along the way.

The EOS® vendor estimated a 3 year timeline for their product for the purpose of estimating the quantity of product needed. This timeline is consistent with the effective duration of the previous interim action injections at the Facility. The presence of nitrate in the injection area was taken into consideration when estimating injection volumes and product timeline as nitrate will compete with chlorinated VOCs for the electrons needed for the degradation process. Nitrate, however, can be beneficial in this system as it provides nutrients for the microbes that anaerobically breakdown the PCE and TCE.

The total volume of substrate to be injected was estimated using the vendor-supplied calculation tool that accounts for both the stoichiometric hydrogen demand of the chemicals (from both the targeted contaminants such as PCE and interfering compounds such as nitrates and sulfates) and the physical limitations of the soil matrix. Appendix B includes the calculation of the amount of substrate to be injected. An estimated 165,000 pounds (50 totes) of EOS substrate will be injected for the expanded interim action.

Preparatory Activities. Prior to the bioinjections, a public and private utility locating service will be contacted to ensure that no buried infrastructure or utilities are located beneath the proposed injection area. If buried structures are identified, then the location (and possibly quantity) of boreholes will need to be adjusted to avoid encountering the buried structures. As an additional safety precaution, each borehole will be cleared to 5 feet bgs using air knife, hand auger, or other minimally invasive excavation technology.

Injection Strategy. To distribute the injection substrate evenly throughout the proposed treatment area, the injections are spaced 25 feet apart with alternate rows offset by half of the spacing. The corresponding layout results in a total of 94 injection points, as shown on Figure 10. Of the 94 proposed injection points, 30 are located off-Property to the northwest of the NuStar Terminal and 60 are located adjacent to the river, along the southern portion of the NuStar terminal Property.

In general, substrate will be injected in the saturated zone over the depth range corresponding to the Shallow Zone. Actual injection depths will be determined at the time of injection. The upper limit will correspond to the top of the water table as determined by the depth to groundwater in monitoring wells within the injection area (generally expected to be on the order of 25 feet). The lower limit is determined by the depth to the silty gravel layer separating the Shallow and Intermediate Zones on the property. Based on prior probe work, the lower limit depth will vary from 40 to 57 feet with most injections being in the 45- to 50-foot depth range. For planning purposes, the injection depths have been assumed to be between 25 to 45 feet, except that injections nearest the river have been assumed to be between 25 to 55 feet.

No appreciable quantity of the substrate, if any, is anticipated to flow into the river; however, injections will be occurring at the top of the riverbank, so it is possible that some substrate may reach the river. The

emulsified food-grade oil will not float on water, yet may segregate into droplets at the river surface and have the overall appearance of watered down milk. The substrate vendor noted that if any substrate made it to the river, it would likely have traveled through a preferential pathway (i.e., coarse grained stratigraphic layer, storm drain, utility corridor, etc.). During past interim action injections, the substrate material was not observed to have migrated far from the point of injection. While there are no known preferential pathways between the seawall area and river, the injection strategy will be managed to limit any migration through a potential preferential pathway. The first six injection locations are denoted on Figure 10. The substrate material will first be injected at locations #1 and #2, the closest injection locations to the river. The field crew will wait approximately 24 hours and will monitor for the presence of substrate material on the river. If the substrate material is not observed in the river, then the crew will continue with injections #3 through #6 in the same manner. If the substrate material is observed in the river, the next adjacent injection will be offset approximately 20 feet away from the river. The injection locations will continue to be offset until no appreciable amount of substrate material is observed in the river. At any point during the injection activities if substrate is observed in the river, then the injection scope may be modified accordingly. The goal of the injections is to achieve the enhanced bioremediation benefits of the injections in the saturated soils located between the seawall and the river, without losing substrate material to the river.

For the injection points located to the northwest of the terminal, there is no concern regarding injection substrate entering the river. These boring locations may need to be relocated or angled to avoid building foundations, buried utilities, or permanently placed equipment inside or out of the warehouse building. The total volume of injected material will remain the same as proposed, but may be distributed differently among boreholes.

Delivery Method. The injection points will be completed using direct-push technology consistent with the methodology used during the 2008 and 2011 bioremediation injection events. An injection probe tip will be advanced to the pre-designated depth at each injection location, withdrawn in 1-foot intervals, and emulsified oil will be injected through the drill stem via an air diaphragm pump. This process is repeated until the substrate has been injected to the top of the saturated zone. Substrate material will not be injected into vadose zone soils. SVE is addressing those portions of the Facility with residual VOCs in vadose zone soil.

Solution Preparation/Injection Volume. The substrate material of emulsified oil concentrate will be diluted with water obtained from the municipal water supply and dechlorinated using a purpose-specific commercial additive (such as sodium thiosulfate). Injections will be diluted at a ratio ranging from 5 to 1 (water: EOS) up to 10 to 1. A lower dilution rate will be utilized for injections in portions of the interim action area where concentrations of VOCs in groundwater are understood to be the most elevated (i.e. near MW-19 and MW-13). Two 1,000-gallon polyethylene tanks will be used to allow simultaneous mixing and injection. Dilution of the solution will be accomplished by combining the EOS® concentrate with water and stirring with

a recirculation pump. Injection rates will be evaluated based on site conditions at the time of drilling, and adjusted accordingly.

Abandonment. The injection borings will be abandoned in accordance with Washington Well Construction and Licensing System (WCLS) regulations and procedures. The abandonment procedure will consist of filling the borehole with granular bentonite to approximately 3 feet below ground surface. Based on our experience from the last two injection events at the Facility, the boreholes stay open after removing the injection rod, allowing access for pouring in bentonite. The borehole will be left open for at least 24 hours to allow the substrate material to distribute before backfilling the hole. The top few feet of the borehole (potentially enlarged from the utility clearance) will be backfilled with concrete. The surface will be patched with similar material to the adjacent surroundings (i.e. concrete, asphalt, gravel, etc.).

Expected Performance Results. The enhanced bioremediation technology is capable of complete destruction of the target compounds (chlorinated VOCs). This has been demonstrated in both laboratory and field applications, including at the Vancouver NuStar terminal. The ability to achieve complete destruction depends on a number of factors such as presence of appropriate bacteria, presence of nutrients, ability to achieve and maintain anaerobic conditions, and presence of competing electron acceptors. The proposed injection strategy should be effective in establishing an anaerobic environment in the targeted saturated zone that will be suitable for bioremediating the VOCs within the finer and courser grained soils in the saturated zone. Usually, the primary factor affecting the ability to achieve complete destruction is the ability to effectively mix the aqueous phase dissolved target compounds with the biosubstrate.

4.0 Proposed Baseline Sediment Sampling

As proposed in the Draft FS, baseline sediment samples will be collected in the Columbia River adjacent to the Facility prior to the bioremediation injections. The data collected will be used to document baseline sediment concentrations prior to the upland groundwater interim action. A description of the shoreline geography, sampling objectives, and sampling methodology are described in the subsections below.

4.1 Objectives

As discussed in Section 2.4, the extent of sediment impacts is limited to an area extending 600 feet along the southern property boundary and 100 feet into the Columbia River from the NuStar shoreline. Migration of impacted upland groundwater appears to have caused the observed VOC impacts to sediments. The primary focus of this interim action is to remediate groundwater beneath the Property where VOC concentrations are elevated. Since source area groundwater concentrations were reduced or eliminated in response to the 2008 and 2011 groundwater interim actions, the residual source (or area of elevated concentrations) is limited to near the southern shoreline at the Facility (Figures 5 – 7). Upon removal of the upland VOC source, it is believed that natural flushing of clean groundwater and surface water through the

sediments will remove the VOCs currently sorbed to the river sediments. In order to evaluate the progress of the sediment cleanup process after the groundwater interim action is initiated, a baseline sediment sampling event is proposed to be implemented immediately prior to the groundwater bioinjections. Surface water samples will be collected immediately prior to the sediment sampling event, to better understand the relationship between groundwater, sediment, and surface water concentrations. Surface water sample locations and methodology are presented in Section 6.0.

4.2 Understanding of Shoreline and River Bathymetry

A seawall borders much of the Property along the boundary with the Columbia River. The Columbia River in the vicinity of the terminal is dredged to a depth of about -42 to -44 feet (Columbia River Datum [CRD]; approximately -36.5 to -43.5 feet MSL referenced to the North American Vertical Datum of 1988 (NAVD88) and is maintained up to the vessel docking berths. The area between the docking berths and the seawall is not dredged as no vessels navigate the landward side of the docking berths. The seawall and approximate extent of river dredging are shown on Figures 8 and 11. Rip-rap has been placed at the riverward side of the seawall and on the slope where the seawall is absent (downstream portion of the Property). During the 2011 sediment investigation, large cobbles to small boulder-sized rocks (likely rip-rap) were encountered at depths ranging from -32 feet to -40 feet MSL. The extent (and depth) to which the boulder cover extends into the channel was further evaluated during the 2012 sediment investigation, and in some areas extends to the dredged zone to roughly -42 feet MSL. A depiction of the Site and river bathymetry extending from the seawall is shown on the cross-section on Figure 12 and is based on river bathymetry maps and seawall structural drawings provided by the POV (Appendix C).

4.3 Sampling Locations and Depths

The proposed sediment sampling locations are shown on Figure 11. Sediment samples will be collected from proposed locations SS-1 through SS-11, as shown on Figure 11. The proposed sediment samples are located in the vicinity of historical sediment samples where VOCs were detected. Locations SS-1 through SS-9 will target the interface between Shallow Zone groundwater and river sediments, and locations SS-10 and SS-11 will target the interface between Intermediate Zone groundwater and sediments. Actual sample locations will be determined in the field using proposed coordinates, mud-line elevation, and presence/absence of rip-rap. If rip-rap is encountered at the desired sampling station, attempts will be made to offset slightly parallel to the shoreline in order to maintain as constant a depth as possible. If rip-rap continues to be encountered, the sampling location may be offset in the direction perpendicular to the shoreline.

The top 6 inches of the core will be collected as the surface sample. Additional samples will be collected at 2-foot intervals (i.e., 0.5 to 2.5 feet, 2.5 to 4.5 feet, etc.) to approximately 7 feet below the mudline. It is possible that refusal may occur before the maximum depth is encountered. A sample will be collected for laboratory analysis from the approximate midpoint of each 2-foot interval. Any required quality assurance

samples (i.e. duplicates, MS/MSD samples, etc.) will also be collected near the midpoint of the sample interval.

4.4 Procedures

The following subsections summarize sediment sampling procedures. Additional information on sampling procedures is provided in the Sampling and Analysis Plan (SAP) provided in Appendix D. The SAP describes procedures for sample location control, documentation, sediment sampling, sample processing, sample containers and handling, equipment decontamination, investigation-derived waste (IDW) management, and data quality assurance.

4.4.1 Sampling Procedures

Sediment cores will be collected using a vessel equipped with a Vibracore sediment coring instrument, or similar, in accordance with Section 2.2 of the SAP. After cores are collected, the cores will be sealed and stored upright on the vessel, until the vessel returns to shore for processing. Processing will be conducted in accordance with Section 2.2 of the SAP.

The sediment core samples will be logged for lithology and screened for VOCs using a photoionization detector (PID). Field screening measurements are intended to comply with standard operating procedures and are not intended to replace laboratory analytical data.

Because the samples will be analyzed for VOCs, samples will not be composited. As required in the *Sediment Cleanup User's Manual II* (SCUM II; Ecology, 2015), sediment samples collected for VOC analyses should be collected into laboratory-approved borosilicate glass containers (50 gram sample minimum) with a T - polytetrafluorethylene (PTFE, Teflon®)-lined septa, with no headspace. Each container will be appropriately labeled and transferred into coolers with ice. The samples will be submitted to a Washington accredited laboratory for analysis. Unless otherwise specified, the samples will be submitted to the laboratory within the 14-day recommended hold time for analysis. Sample results will be reported in milligrams per kilogram (mg/kg) as dry weight. Additional jars of sediment will be collected at each sample location for dry weight analysis, total organic carbon (TOC) analysis, and for potential future grain size analysis.

4.4.2 Control of Station and Sample Locations

A positioning procedure will be utilized to ensure that the proposed sampling stations are achieved and to accurately determine the horizontal and vertical positions of the sampling stations. This determination will be achieved by referencing each sampling location to state plane coordinates through the use of known survey control points, onshore landmarks, and a differential global positioning system (GPS). The following parameters will be documented at each sampling location:

-
- Time and date;
 - Horizontal location in local grid coordinates, referenced to North American Datum of 1983 (NAD83);
 - River level and mudline elevations referenced to NAVD88.

These parameters will be measured from the sampling vessel using a combination of differential GPS, pre-surveyed visual horizontal triangulation to known control points (e.g., surveyed on-site monitoring wells, benchmarks, etc.) and/or permanent structures onshore, single beam echo sounder data, and weighted tape measures. Additional information on vertical and horizontal sample control is provided in Section 1.0 of the SAP (Appendix D).

4.5 Chemical Analytes

The sediment samples will be analyzed for halogenated VOCs by EPA Method 8260B. The use of EPA Method 8260 is consistent with current and historical investigations of soil and groundwater at the Site. Other than chlorinated solvents, no other chemicals were identified at the Site that would present a risk to human or ecological receptors. In addition, select sediment samples will also be analyzed for TOC by EPA Method 9060A.

5.0 Proposed Baseline Surface Water Sampling

Surface water data will be collected to assess the habitat for fish swimming near sediments at the Site. Surface water samples will be collected prior to the sediment sampling event to avoid sampling potentially disturbed water with suspected sediment from the sediment sampling effort. The surface water samples will be collected from four locations; two immediately downgradient from the upland source area and in the vicinity of the highest VOC concentrations in sediments, one in an upgradient location where historical VOC concentrations in sediment have been low to non-detect, and one down-gradient where historical VOC concentrations in sediment have been low to non-detect (see Figure 11). Surface water samples will be targeted at a depth of approximately 6 to 8 inches above the river sediment. This will target surface water in close proximity to the groundwater-sediment interface where VOC concentrations in surface water have the highest probability of being elevated.

Sample Collection Method. At the request of Ecology, surface water samples will be collected into a passive diffusion bag (PDB) placed at the surface water-sediment interface. The sampling methodology is described below and detailed in the SAP (Appendix D):

- The selected PDB will be a minimum of 24 inches long and 1.5 inches in diameter. This will hold 220 mL of water, adequate to fill five (5) 40 mL VOA containers. The PDB will be prefilled with ASTM Type II certified, laboratory-grade, analyte-free, deionized water.

-
- The PDB will be attached to an approximately 2 by 2 foot aluminum expanded sheet using zip ties. These sheets will allow water to pass through the sheet as it is lowered into the river to the river bottom. The sheet may be weighted at the corners if needed. The use of an expanded sheet will allow the passive membrane to lie at the sediment interface while not sinking into the sediment, and also allows for easy deployment and retrieval without the use of a diver.
 - A line will be attached to the expanded aluminum sheet and attached to a buoy, to allow for retrieval. Given that the river bottom will not likely be visible from the sampling vessel, a camera will be dropped down alongside the line to ensure the sampler is placed on a flat surface.
 - Depending on access, which may be limited by shipping vessel traffic at the docking berth, the PDB will be retrieved in 48 to 96 hours after deployment. The duration of PDB deployment will be recorded in the field notes.
 - After retrieving the PDB, it will be removed from the expanded aluminum sheet for sample processing.

Sample Handling and Analysis. A simple cut will be made at top of the PDB, and the surface water will be poured directly into laboratory approved sampling containers (SAP; Table D-2) and stored on ice. Because the samples will be analyzed for volatile constituents, care will be taken to not have any headspace in the sample. The surface water samples will be submitted to a Washington accredited laboratory for HVOCs by EPA Method 8260B. Unless otherwise specified, the samples will be submitted to the laboratory within the 14-day recommended hold time for analysis. Additional information on surface water sampling procedures is provided in the SAP (Appendix D).

6.0 Schedule

In order to evaluate and document sediment and surface water conditions prior to the upland groundwater interim action, sediment and surface water sampling will be conducted prior to the bioremediation injections. Both sediment and surface water sampling will have to be coordinated with the POV vessel traffic schedule. It is estimated the surface water and sediment sampling will take 5 to 9 days to complete.

Following sediment and surface water sampling, the bioremediation effort is expected to require 5 to 8 weeks in the field, depending on the achievable injection rate. These injections could begin within 4-6 weeks of a notice to proceed (based on the vendor's estimate of needed lead-time to deliver the product). The injection schedule would need to be coordinated with terminal and POV personnel as the work will be completed within areas of the NuStar terminal and the POV and in the vicinity of area roadways, rail spurs, and occupied warehouses.

7.0 Reporting

Approximately 7 months after the interim action implementation activities are completed, an Interim Action Results Report will be submitted to Ecology documenting the first six months of monitoring activities. The report will include a summary of the sediment and surface water sampling events, and a description of the enhanced bioremediation injection activities. The results report will also include a summary of groundwater analytical data from the two quarterly monitoring events conducted after the groundwater injections are completed, as well as a potential discussion of initial VOC reductions in response to the interim action. Based on the results of the 2008 and 2011 interim actions, reductions of VOCs are anticipated to be observed within the first one to two monitoring events (3 to 6 months) after the injections.

8.0 References

- AMEC, 2005. *Remedial Investigation Report Update Report, Cadet Manufacturing Company Prepared for Cadet Manufacturing Company, Vancouver, Washington.* August, 2005.
- Ash Creek Associates, 2006. *Interim Action Analysis Report, ST Services, Vancouver, Washington.* November 28, 2006.
- Ash Creek Associates, 2008. *Baseline Risk Assessment Report, NuStar Vancouver Main Terminal, Vancouver, Washington.* September 4, 2008.
- Ash Creek Associates, 2011. *Interim Action Work Plan, NuStar Vancouver Facility, Vancouver Washington.* March 25, 2011
- Ash Creek Associates, 2012. *2011 Interim Action Evaluation Report, NuStar Vancouver Facility, Vancouver Washington.* March 29, 2012
- Ash Creek Associates, 2012a. *2011 Groundwater Flow Evaluation Report, NuStar Vancouver Facility, Vancouver Washington*
- Apex Companies, LLC (Apex), 2013. *Final Remedial Investigation Report, NuStar Terminals Services Inc. Vancouver Terminal, Vancouver Washington.* August 14, 2013
- Apex Companies, LLC (Apex), 2015. *Semi-Annual Groundwater Monitoring Report January through June 2015. NuStar Vancouver Facility, Vancouver, Washington.* August 14, 2015.
- DOD, 2006. *Protocol for Enhanced In Situ Bioremediation Using Emulsified Edible Oil,* Department of Defense ESTCP – Solutions IES, March 2006.
- Ecology 2013. *Sediment Management Standards. Chapters 173-204 WAC. Revised February 2013, effective September 2013.*
- Ecology, 2015. *FINAL Sediment Cleanup Users Manual II (SCUM II). Publication No. 12-09-057. Revised March 2015.*
- Parametrix, 2008. *Vancouver Lake Lowlands Groundwater Model Summary Report.* February 15, 2008.
- Parametrix and Apex, 2015. *Feasibility Study Report, Port of Vancouver and NuStar Terminal Services. Vancouver, Washington.* January 2015
- SECOR International, Inc., 1999b. *Final Interim Action Pilot Study Work Plan.* January 20, 1999.
- SECOR International, Inc., 1999c. *Response to Ecology's Comments Letter.* June 24, 1999.
- SECOR International, Inc., 2000a. *Final Interim Action Work Plan.* April 7, 2000.
- SECOR International, Inc., 2001. *Final Remedial Investigation Report, Vancouver Terminal, Port of Vancouver Terminal No. 2, Vancouver, Washington.* October 19, 2001.

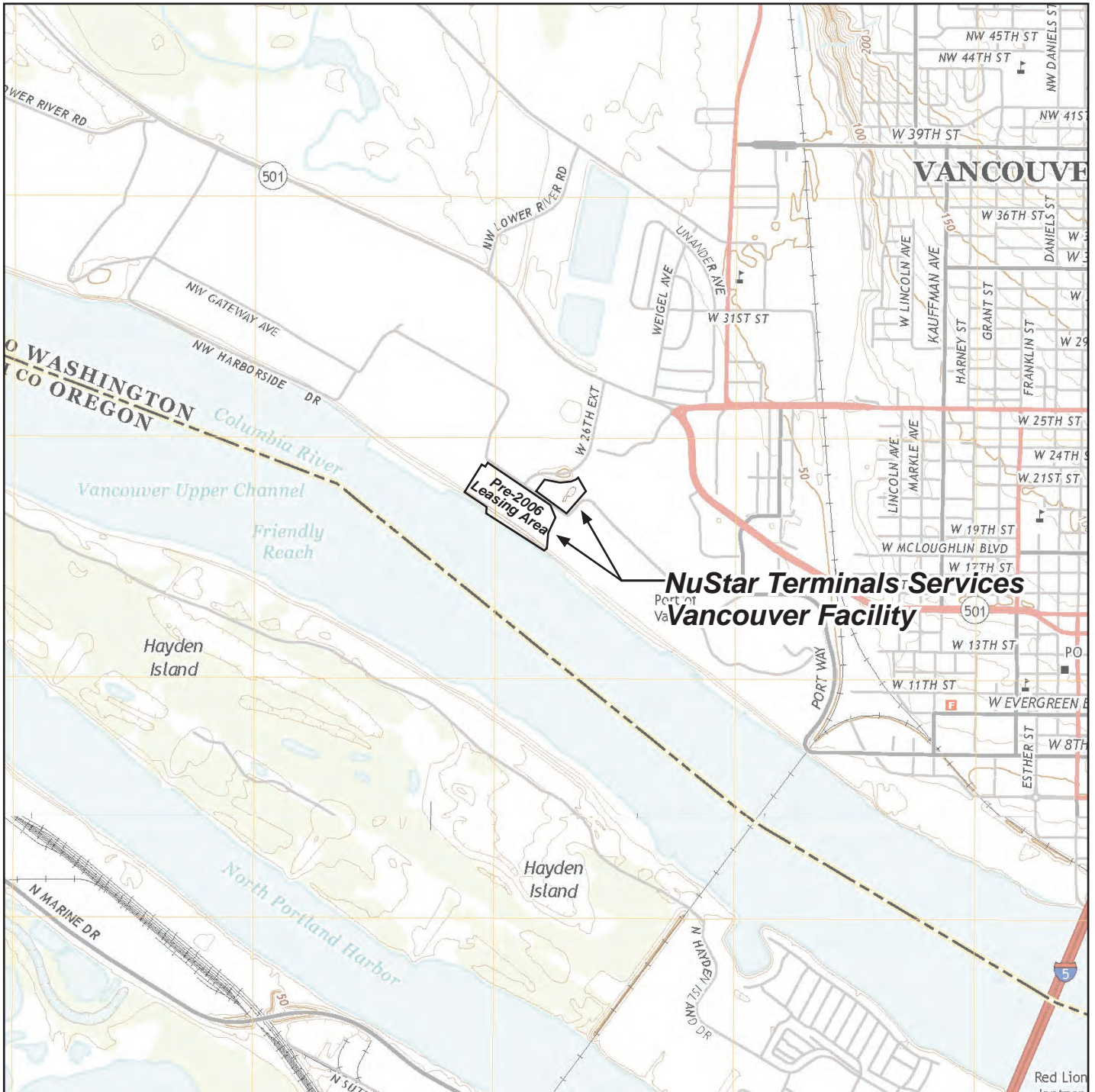

Note: Base map prepared from USGS 7.5-minute quadrangles of Vancouver, WA and Portland, OR-WA, dated 2014 as provided by USGS.gov.

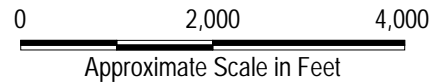

Facility Location Map
 2015 Interim Action Work Plan
 NuStar Terminals Services, Inc. Vancouver Facility
 Vancouver, Washington

 Apex Companies, LLC
 3015 SW First Avenue
 Portland, Oregon 97201

Project Number	1126-17
September 2015	

Figure
1

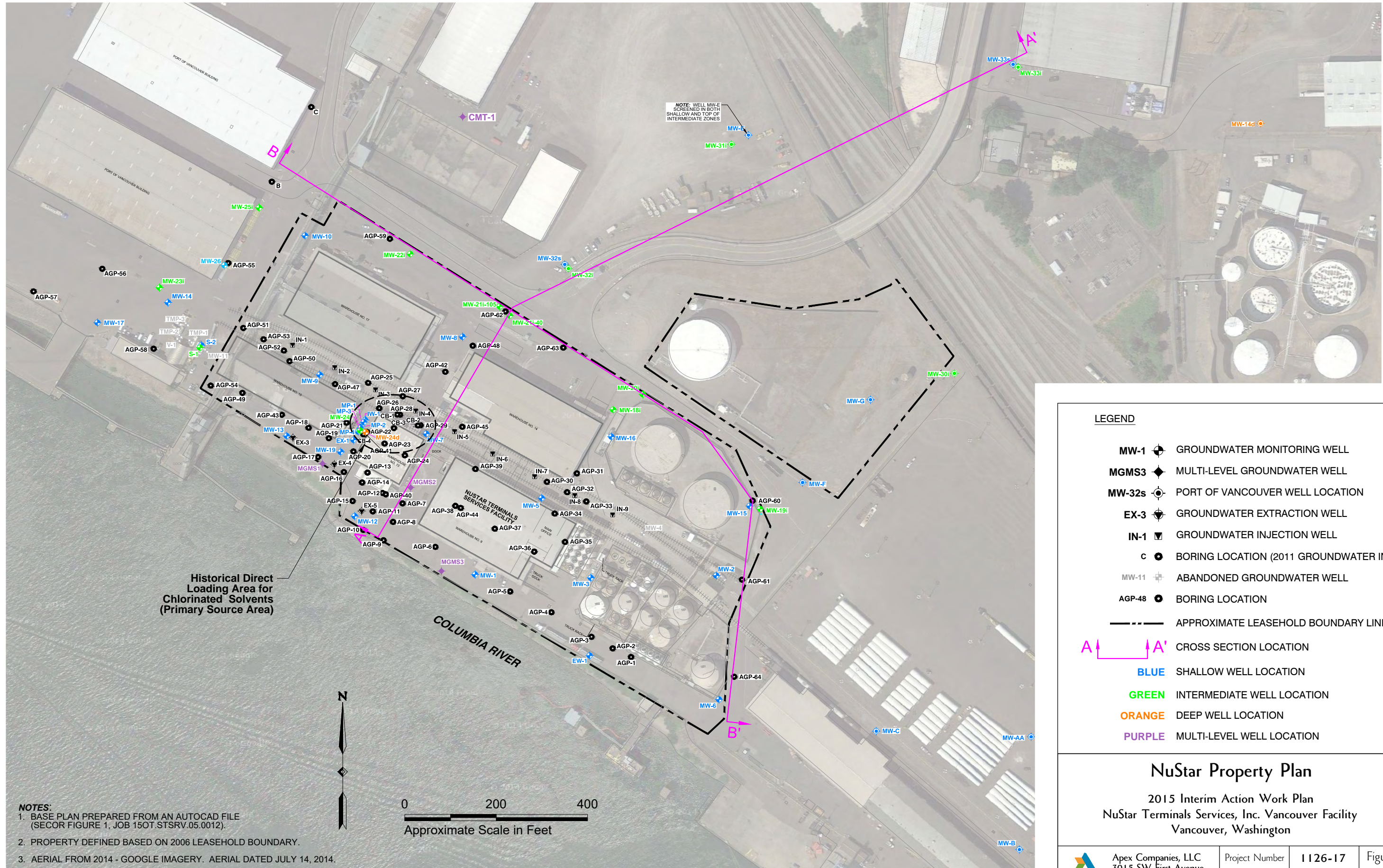

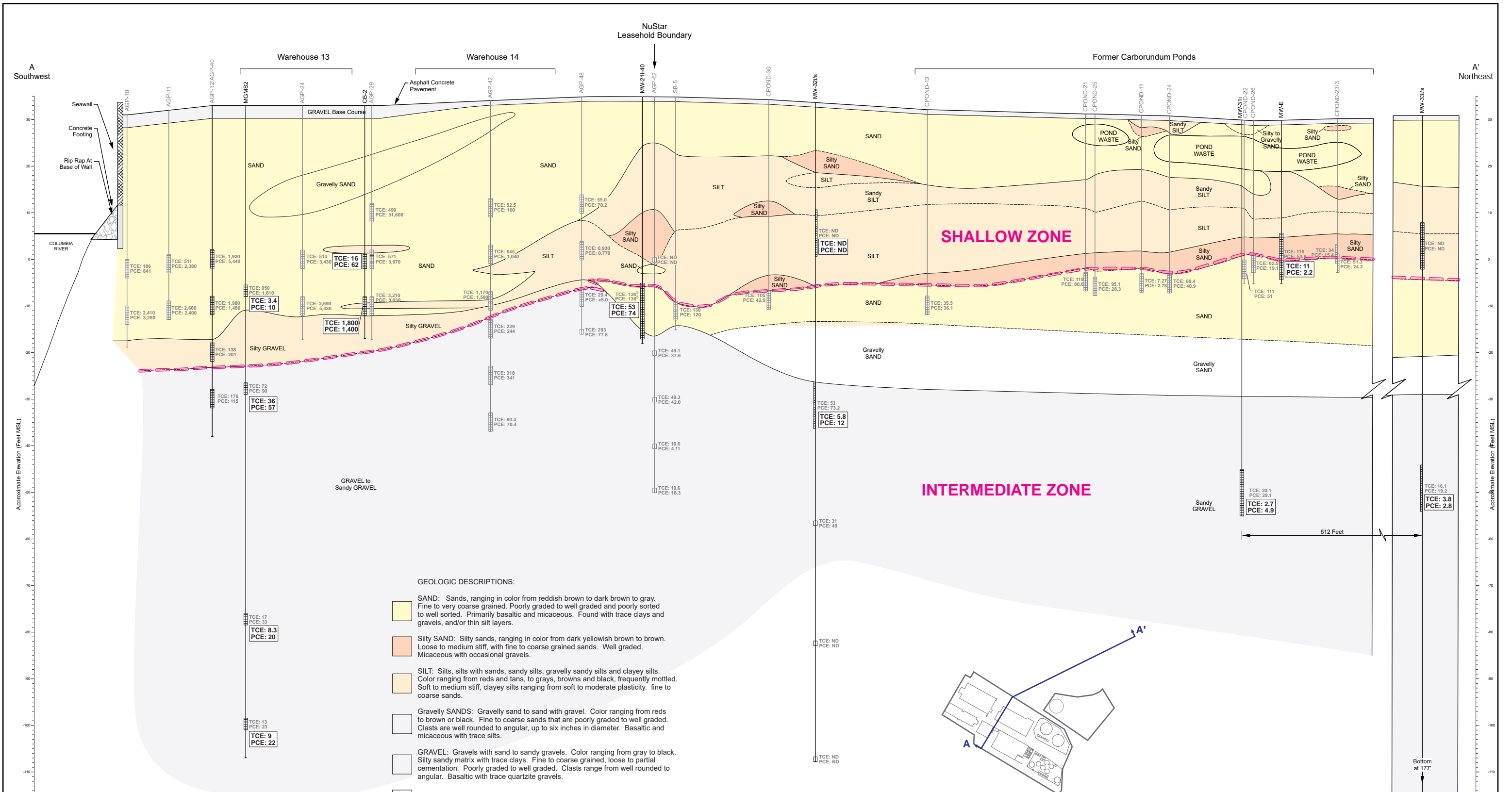

- GEOLOGIC DESCRIPTIONS:**
- SAND:** Sands, ranging in color from reddish brown to dark brown to gray. Fine to very coarse grained. Poorly graded to well graded and poorly sorted to well sorted. Primarily basaltic and micaceous. Found with trace clays and gravels, and/or thin silt layers.
 - Silty SAND:** Silty sands, ranging in color from dark yellowish brown to brown. Loose to medium stiff, with fine to coarse grained sands. Well graded. Micaceous with occasional gravels.
 - SILT:** Silts, silts with sands, sandy silts, gravelly sandy silts and clayey silts. Color ranging from reds and tans, to grays, browns and black, frequently mottled. Soft to medium stiff, clayey silts ranging from soft to moderate plasticity. Fine to coarse sands.
 - Gravelly SANDS:** Gravelly sand to sand with gravel. Color ranging from reds to brown or black. Fine to coarse sands that are poorly graded to well graded. Clasts are well rounded to angular, up to six inches in diameter. Basaltic and micaceous with trace silts.
 - GRAVEL:** Gravels with sand to sandy gravels. Color ranging from gray to black. Silty sandy matrix with trace clays. Fine to coarse grained, loose to partial cementation. Poorly graded to well graded. Clasts range from well rounded to angular. Basaltic with trace quartzite gravels.
 - POND WASTE**

- Sampling Notes:**
1. Historical Data (in grey):
 - a. NuStar (AGP) data from 2006; "SB" boring data from March 2005.
 - b. Off-facility well data from March 2006; "C-Pond" data collected by Parametrix in March 2005.
 - c. Historical monitoring well data from March/June 2008.
 2. Recent Data (in black, boxed):
 - a. Monitoring well data from September or December 2012.
 - b. Boring CB-2 data from September 2010.
 3. ND = Not detected (reporting limit of 0.5 µg/L unless otherwise specified).

- Legend:**
- Borehole
 - Recent Trichloroethene (TCE) Concentration in µg/L
 - Recent Tetrachloroethene (PCE) Concentration in µg/L
 - Screened Interval
 - Depth Discrete Sample Location
 - Historical TCE Concentration in µg/L
 - Historical PCE Concentration in µg/L
 - Boundary Between Shallow and Intermediate Zone Groundwater

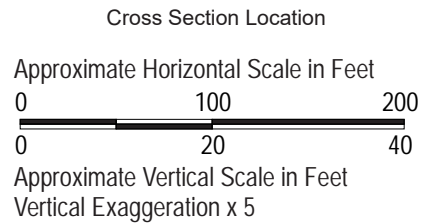
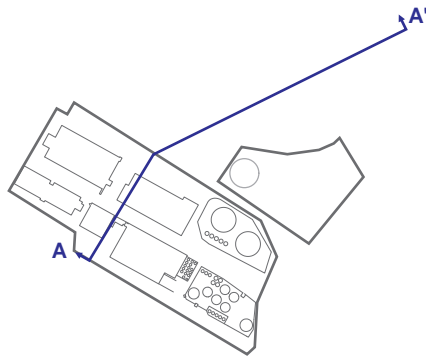

Geologic Cross-Section A-A'

2015 Interim Action Work Plan
NuStar Terminals Services, Inc. Vancouver Facility
Vancouver, Washington

Apex Companies, LLC 3015 SW First Avenue Portland, Oregon 97201	Project Number	1126-17	Figure 3
	September 2015		

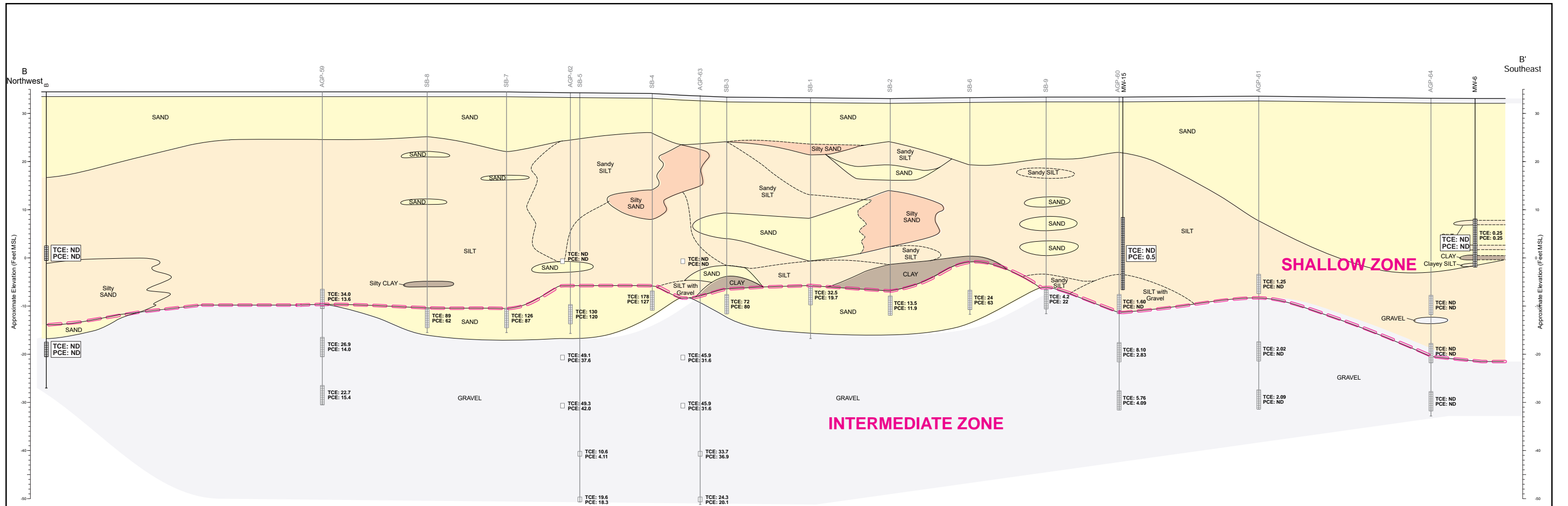

GEOLOGIC DESCRIPTIONS:

- SAND:** Sands, ranging in color from reddish brown to dark brown to gray. Fine to very coarse grained. Poorly graded to well graded and poorly sorted to well sorted. Primarily basaltic and micaceous. Found with trace clays and gravels, and/or thin silt layers.
- Silty SAND:** Silty sands, ranging in color from dark yellowish brown to brown. Loose to medium stiff, with fine to coarse grained sands. Well graded. Micaceous with occasional gravels.
- SILT:** Silts, silts with sands, sandy silts, gravelly sandy silts and clayey silts. Color ranging from reds and tans, to grays, browns and black, frequently mottled. Soft to medium stiff, clayey silts ranging from soft to moderate plasticity. fine to coarse sands.
- GRAVEL:** Gravels with sand to sandy gravels. Color ranging from gray to black. Silty sandy matrix with trace clays. Fine to coarse grained, loose to partial cementation. Poorly graded to well graded. Clasts range from well rounded to angular. Basaltic with trace quartzite gravels.
- CLAY:** Clays to silty clays. Color ranging from green/gray to black. Medium plasticity, sticky, stiff, ranging from dry to moist.

Legend:

- Borehole
- Recent Trichloroethene (TCE) Concentration in µg/L
- Recent Tetrachloroethene (PCE) Concentration in µg/L
- Screened Interval
- Depth Discrete Sample Location

- TCE: 176
PCE: 115
- Historical TCE Concentration in µg/L
- Historical PCE Concentration in µg/L
- Boundary Between Shallow and Intermediate Zone Groundwater

Sampling Notes:

1. Historical Data (in grey):
 - a. NuStar (AGP) data from 2006; "SB" boring data from March 2005.
 - b. Historical monitoring well data from March/June 2008.
2. Recent Data (in black; boxed):
 - a. Monitoring well data from September or December 2012.
3. ND = Not detected (reporting limit of 0.5 µg/L unless otherwise specified).

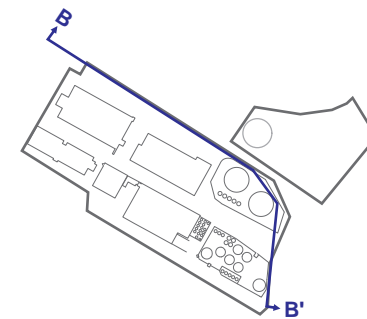

Cross Section Location

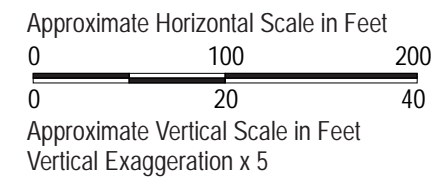

Geologic Cross-Section B-B

2015 Interim Action Work Plan
 NuStar Terminals Services, Inc. Vancouver Facility
 Vancouver, Washington

APEX Apex Companies, LLC
 3015 SW First Avenue
 Portland, Oregon 97201

Project Number	1126-17	Figure	4
September 2015			

PCE in Shallow Zone 1Q 2008



PCE in Shallow Zone 1Q 2013



LEGEND:

- ⊙ Swan Manufacturing (POV) Monitoring Well
- ⊙ ST Services (NuStar) Monitoring Well
- Property Line

- 1.16 Concentration in Groundwater (µg/L)
- NA Not Available; Well MW-26 Installed in 2011
*Groundwater data from boring AGP-55 are presented in 2008 figure to define the extent of Volatile Organic Compounds to the northwest. Well MW-26 was installed in 2011 at the same location as boring AGP-55.
- 5µg/L Isoconcentration Contour (MCL)
- 20µg/L Isoconcentration Contour (MCL)
- 200µg/L Isoconcentration Contour (MCL)
- 1,000µg/L Isoconcentration Contour (MCL)
- 10,000µg/L Isoconcentration Contour (MCL)

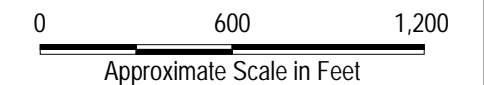

NOTE:
Base Map, Legend and Scale from S.S. Papadopoulos & Associates, Inc. Expert Report of Dimitrios Vlassopoulos Port of Vancouver v. Cadet Manufacturing Company, May 2005

2008 and 2013 Isocontours of Tetrachloroethene (PCE) Concentrations in Shallow Zone Groundwater
2015 Interim Action Work Plan
NuStar Terminals Services, Inc. Vancouver Facility
Vancouver, Washington

APEX Apex Companies, LLC
3015 SW First Avenue
Portland, Oregon 97201

Project Number	1126-17
September 2015	

Figure
5

TCE in Shallow Zone 1Q 2008



TCE in Shallow Zone 1Q 2013

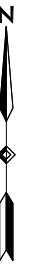

LEGEND:

- ⊙ Swan Manufacturing (POV) Monitoring Well
- ⊙ ST Services (NuStar) Monitoring Well
- - - - - Property Line

19.9	Concentration in Groundwater (µg/L)
NA	Not Available; Well MW-26 Installed in 2011 *Groundwater data from boring AGP-55 are presented in 2008 figure to define the extent of Volatile Organic Compounds to the northwest. Well MW-26 was installed in 2011 at the same location as boring AGP-55.
—	4µg/L Isoconcentration Contour (MCL)
—	20µg/L Isoconcentration Contour (MCL)
—	200µg/L Isoconcentration Contour (MCL)
—	1,000µg/L Isoconcentration Contour (MCL)

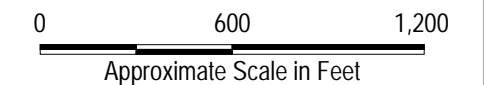

NOTE:
Base Map, Legend and Scale from S.S. Papadopoulos & Associates, Inc. Expert Report of Dimitrios Vlassopoulos Port of Vancouver v. Cadet Manufacturing Company, May 2005

2008 and 2013 Isocontours of Trichloroethene (TCE) Concentrations in Shallow Zone Groundwater
2015 Interim Action Work Plan
NuStar Terminals Services, Inc. Vancouver Facility
Vancouver, Washington

APEX Apex Companies, LLC
3015 SW First Avenue
Portland, Oregon 97201

Project Number	1126-17
September 2015	

Figure
6

cDCE in Shallow Zone 1Q 2008



cDCE in Shallow Zone 1Q 2013



LEGEND:

- ⊙ Swan Manufacturing (POV) Monitoring Well
- ST Services (NuStar) Monitoring Well
- - - - - Property Line

5.75	Concentration in Groundwater (µg/L)
NA	Not Available; Well MW-26 Installed in 2011 *Groundwater data from boring AGP-55 are presented in 2008 figure to define the extent of Volatile Organic Compounds to the northwest. Well MW-26 was installed in 2011 at the same location as boring AGP-55.
— (blue line)	16µg/L Isoconcentration Contour (MCL)
— (orange line)	200µg/L Isoconcentration Contour (MCL)
— (pink line)	1,000µg/L Isoconcentration Contour (MCL)

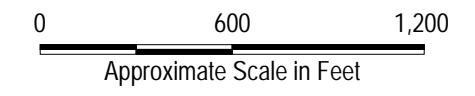

NOTE:
Base Map, Legend and Scale from S.S. Papadopoulos & Associates, Inc. Expert Report of Dimitrios Vlassopoulos Port of Vancouver v. Cadet Manufacturing Company, May 2005

2008 and 2013 Isocontours of cis-1,2-Dichloroethene (cDCE) Concentrations in Shallow Zone Groundwater
2015 Interim Action Work Plan
NuStar Terminals Services, Inc. Vancouver Facility
Vancouver, Washington

Apex Companies, LLC 3015 SW First Avenue Portland, Oregon 97201	Project Number	1126-17	Figure	7
	September 2015			

ABBREVIATIONS:

PCE	TETRACHLOROETHENE
TCE	TRICHLOROETHENE
cis-1,2-DCE	CIS-1,2-DICHLOROETHENE
VC	VINYL CHLORIDE

- NOTES:**
1. BASE PLAN PREPARED FROM AN AUTOCAD FILE (SECOR FIGURE 1, JOB 150T.STSRV.05.0012).
 2. PROPERTY DEFINED BASED ON 2006 LEASEHOLD BOUNDARY.
 3. AERIAL PHOTOGRAPH FROM GOOGLE.COM (2011).
 4. ONLY SURFACE SAMPLE AND SHALLOWEST SUBSURFACE SAMPLE DATA ARE PRESENTED ON FIGURE. DATA FOR DEEPER SAMPLES ARE PROVIDED IN TABLE 6.
 5. GROUNDWATER DATA FROM FIRST QUARTER 2008.
 6. * = DATA FROM WELLS MP-1 AND EX ARE FROM MARCH 2009. THESE WELLS WERE NOT SAMPLED IN 2008.

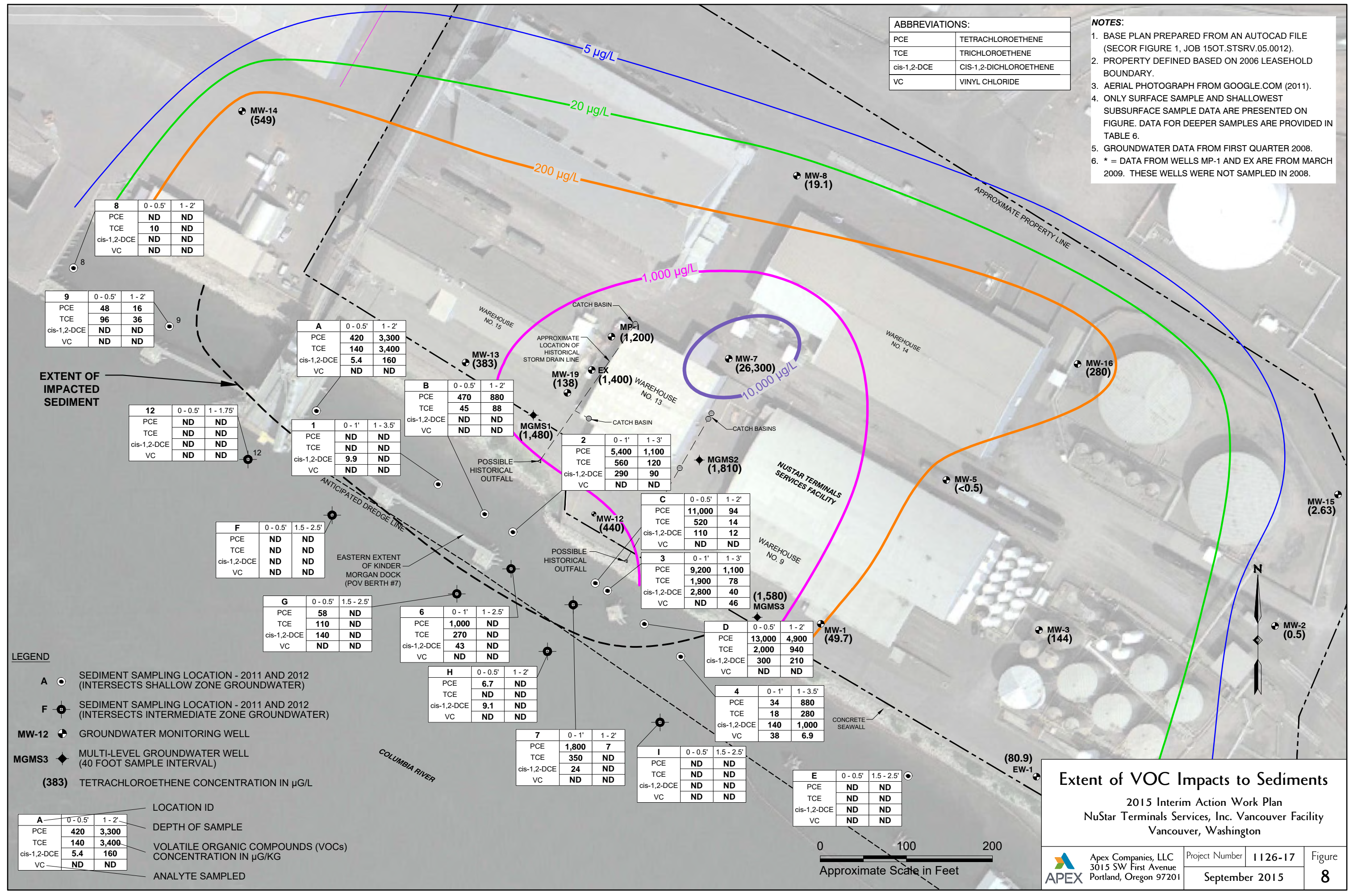

8

	0 - 0.5'	1 - 2'
PCE	ND	ND
TCE	10	ND
cis-1,2-DCE	ND	ND
VC	ND	ND

9

	0 - 0.5'	1 - 2'
PCE	48	16
TCE	96	36
cis-1,2-DCE	ND	ND
VC	ND	ND

A

	0 - 0.5'	1 - 2'
PCE	420	3,300
TCE	140	3,400
cis-1,2-DCE	5.4	160
VC	ND	ND

B

	0 - 0.5'	1 - 2'
PCE	470	880
TCE	45	88
cis-1,2-DCE	ND	ND
VC	ND	ND

2

	0 - 1'	1 - 3'
PCE	5,400	1,100
TCE	560	120
cis-1,2-DCE	290	90
VC	ND	ND

C

	0 - 0.5'	1 - 2'
PCE	11,000	94
TCE	520	14
cis-1,2-DCE	110	12
VC	ND	ND

3

	0 - 1'	1 - 3'
PCE	9,200	1,100
TCE	1,900	78
cis-1,2-DCE	2,800	40
VC	ND	46

D

	0 - 0.5'	1 - 2'
PCE	13,000	4,900
TCE	2,000	940
cis-1,2-DCE	300	210
VC	ND	ND

4

	0 - 1'	1 - 3.5'
PCE	34	880
TCE	18	280
cis-1,2-DCE	140	1,000
VC	38	6.9

7

	0 - 1'	1 - 2'
PCE	1,800	7
TCE	350	ND
cis-1,2-DCE	24	ND
VC	ND	ND

I

	0 - 0.5'	1.5 - 2.5'
PCE	ND	ND
TCE	ND	ND
cis-1,2-DCE	ND	ND
VC	ND	ND

E

	0 - 0.5'	1.5 - 2.5'
PCE	ND	ND
TCE	ND	ND
cis-1,2-DCE	ND	ND
VC	ND	ND

12

	0 - 0.5'	1 - 1.75'
PCE	ND	ND
TCE	ND	ND
cis-1,2-DCE	ND	ND
VC	ND	ND

1

	0 - 1'	1 - 3.5'
PCE	ND	ND
TCE	ND	ND
cis-1,2-DCE	9.9	ND
VC	ND	ND

F

	0 - 0.5'	1.5 - 2.5'
PCE	ND	ND
TCE	ND	ND
cis-1,2-DCE	ND	ND
VC	ND	ND

G

	0 - 0.5'	1.5 - 2.5'
PCE	58	ND
TCE	110	ND
cis-1,2-DCE	140	ND
VC	ND	ND

6

	0 - 1'	1 - 2.5'
PCE	1,000	ND
TCE	270	ND
cis-1,2-DCE	43	ND
VC	ND	ND

H

	0 - 0.5'	1 - 2'
PCE	6.7	ND
TCE	ND	ND
cis-1,2-DCE	9.1	ND
VC	ND	ND

- LEGEND**
- A** ○ SEDIMENT SAMPLING LOCATION - 2011 AND 2012 (INTERSECTS SHALLOW ZONE GROUNDWATER)
 - F** ⊕ SEDIMENT SAMPLING LOCATION - 2011 AND 2012 (INTERSECTS INTERMEDIATE ZONE GROUNDWATER)
 - MW-12** ⊕ GROUNDWATER MONITORING WELL
 - MGMS3** ◆ MULTI-LEVEL GROUNDWATER WELL (40 FOOT SAMPLE INTERVAL)
 - (383)** TETRACHLOROETHENE CONCENTRATION IN µG/L

LOCATION ID	0 - 0.5'	1 - 2'
PCE	420	3,300
TCE	140	3,400
cis-1,2-DCE	5.4	160
VC	ND	ND

DEPTH OF SAMPLE

VOLATILE ORGANIC COMPOUNDS (VOCs) CONCENTRATION IN µG/KG

ANALYTE SAMPLED

Extent of VOC Impacts to Sediments

2015 Interim Action Work Plan
NuStar Terminals Services, Inc. Vancouver Facility
Vancouver, Washington



LEGEND:

- 2011 INTERIM ACTION STANDARD OIL SUBSTRATE INJECTION POINT
- 2011 ANGLED INJECTION POINT
- 2008 INTERIM ACTION INJECTION POINT
- EX-3 EARLY 2000s INTERIM ACTION GROUNDWATER EXTRACTION WELL
- IN-1 EARLY 2000s INTERIM ACTION GROUNDWATER INJECTION WELL AND VAPOR EXTRACTION WELL
- MW-1 GROUNDWATER MONITORING WELL
- MGMS3 MULTI-LEVEL GROUNDWATER WELL
- CATCH BASIN
- BUILDING
- FENCE
- ELECTRICAL
- SYSTEM ELECTRICAL
- STORM SEWER
- WATER
- MANHOLE
- RAILROAD TRACKS

Extent of 2008 and 2011 Groundwater Interim Action
 2015 Interim Action Work Plan
 NuStar Terminals Services, Inc. Vancouver Facility
 Vancouver, Washington

NOTES:

1. BASE PLAN PREPARED FROM AN AUTOCAD FILE (SECOR FIGURE 1, JOB 150T.STSRV.05.0012).
2. UTILITY LOCATIONS SHOWN BASED ON SURFACE MARKINGS BY UTILITY LOCATOR.
3. INJECTION LOCATIONS BASED ON FIELD MEASUREMENTS TO EXISTING SITE STRUCTURES.



LEGEND:

- PROPOSED ENHANCED BIOREMEDIATION INJECTION POINT
- INITIAL INJECTION ORDER (SEE NOTE 4)
- 2011 INTERIM ACTION STANDARD OIL SUBSTRATE INJECTION POINT
- 2011 INTERIM ACTION ANGLED INJECTION POINT
- 2008 INTERIM ACTION INJECTION POINT
- EX-3 EARLY 2000s INTERIM ACTION GROUNDWATER EXTRACTION WELL
- IN-1 EARLY 2000s INTERIM ACTION GROUNDWATER INJECTION WELL AND VAPOR EXTRACTION WELL
- MW-1 GROUNDWATER MONITORING WELL
- MGMS3 MULTI-LEVEL GROUNDWATER WELL
- CATCH BASIN
- BUILDING
- FENCE
- ELECTRICAL
- SYSTEM ELECTRICAL
- STORM SEWER
- WATER
- MANHOLE
- RAILROAD TRACKS

Enhanced Bioremediation Design
 2015 Interim Action Work Plan
 NuStar Terminals Services, Inc. Vancouver Facility
 Vancouver, Washington

- NOTES:**
1. BASE PLAN PREPARED FROM AN AUTOCAD FILE (SECOR FIGURE 1, JOB 150T.STSRV.05.0012).
 2. UTILITY LOCATIONS SHOWN BASED ON SURFACE MARKINGS BY UTILITY LOCATOR.
 3. INJECTION LOCATIONS BASED ON FIELD MEASUREMENTS TO EXISTING SITE STRUCTURES.
 4. LOCATIONS 1 THROUGH 6 DEPICT THE ORDER OF THE FIRST 6 BIOINJECTIONS. SEE SECTION 3.0 OF TEXT FOR ADDITIONAL INFORMATION.

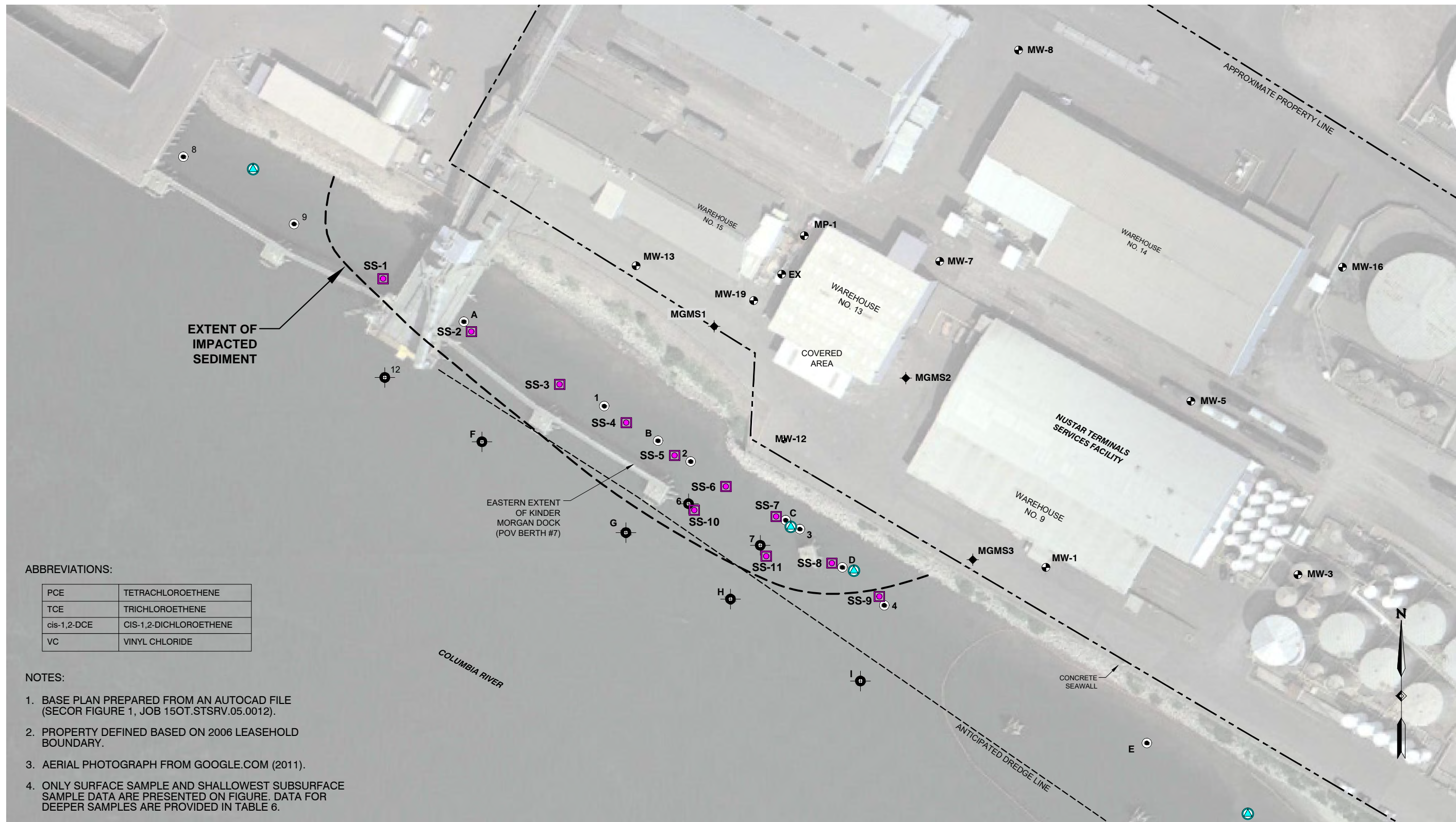

ABBREVIATIONS:

PCE	TETRACHLOROETHENE
TCE	TRICHLOROETHENE
cis-1,2-DCE	CIS-1,2-DICHLOROETHENE
VC	VINYL CHLORIDE

NOTES:

1. BASE PLAN PREPARED FROM AN AUTOCAD FILE (SECOR FIGURE 1, JOB 15OT.STSRV.05.0012).
2. PROPERTY DEFINED BASED ON 2006 LEASEHOLD BOUNDARY.
3. AERIAL PHOTOGRAPH FROM GOOGLE.COM (2011).
4. ONLY SURFACE SAMPLE AND SHALLOWEST SUBSURFACE SAMPLE DATA ARE PRESENTED ON FIGURE. DATA FOR DEEPER SAMPLES ARE PROVIDED IN TABLE 6.

LEGEND

- A SEDIMENT SAMPLING LOCATION - 2011 AND 2012 (INTERSECTS SHALLOW ZONE GROUNDWATER)
- F SEDIMENT SAMPLING LOCATION - 2011 AND 2012 (INTERSECTS INTERMEDIATE ZONE GROUNDWATER)
- MW-12 GROUNDWATER MONITORING WELL
- MGMS3 MULTI-LEVEL GROUNDWATER WELL (40 FOOT SAMPLE INTERVAL)
- SS-1 PROPOSED SEDIMENT SAMPLING LOCATION (2015/2016)
- PROPOSED SURFACE WATER SAMPLING LOCATION

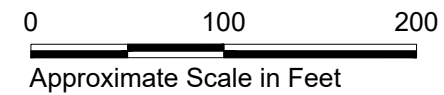

Proposed Sediment Sampling and Surface Water Locations

2015 Interim Action Work Plan
NuStar Terminals Services, Inc. Vancouver Facility
Vancouver, Washington

Apex Companies, LLC 3015 SW First Avenue Portland, Oregon 97201	Project Number	1126-17	Figure 11
	September 2015		

A
Southwest

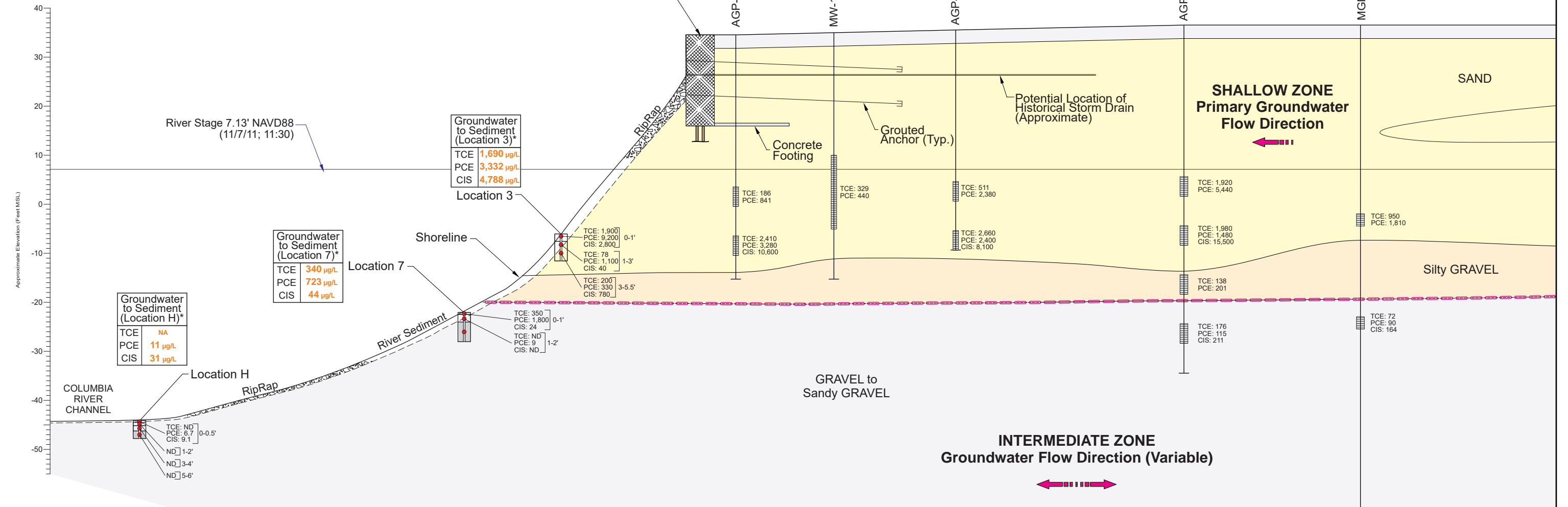

Legend

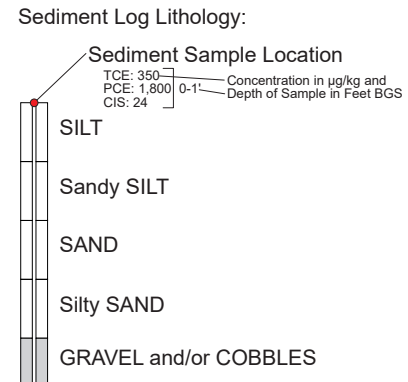

GEOLOGIC DESCRIPTIONS:

- SAND:** Sands, ranging in color from reddish brown to dark brown to gray. Fine to very coarse grained. Poorly graded to well graded and poorly sorted to well sorted. Primarily basaltic and micaceous. Found with trace clays and gravels, and/or thin silt layers.
- SILT:** Silts, silts with sands, sandy silts, gravelly sandy silts and clayey silts. Color ranging from reds and tans, to grays, browns and black, frequently mottled. Soft to medium stiff, clayey silts ranging from soft to moderate plasticity. Fine to coarse sands.
- Gravelly SANDS:** Gravelly sand to sand with gravel. Color ranging from reds to brown or black. Fine to coarse sands that are poorly graded to well graded. Clasts are well rounded to angular, up to six inches in diameter. Basaltic and micaceous with trace silts.
- GRAVEL:** Gravels with sand to sandy gravels. Color ranging from gray to black. Silty sandy matrix with trace clays. Fine to coarse grained, loose to partial cementation. Poorly graded to well graded. Clasts range from well rounded to angular. Basaltic with trace quartzite gravels.
- River Sediment**

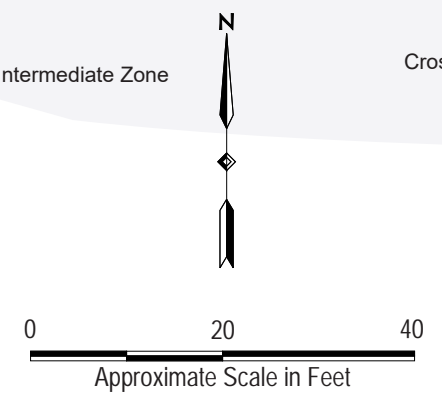
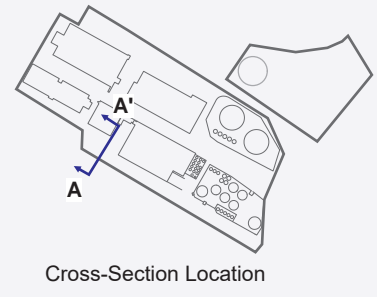
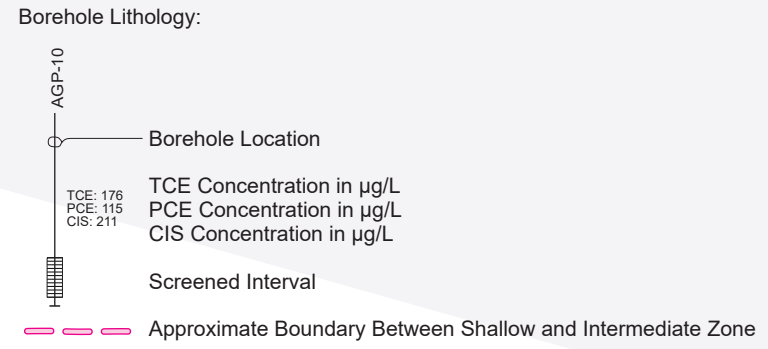

Shoreline Geologic Cross-Section A-A'

2015 Interim Action Work Plan
NuStar Terminals Services, Inc. Vancouver Facility
Vancouver, Washington

* Using the MTCA Three Phase Equilibrium Partitioning Equation (Eqn. 747-1), represents the minimum VOC concentration in groundwater needed to partition to sediments at the concentration present in the surface-most sediment sample. Concentration data for the surface-most sediment sample are depicted on the sediment core diagram.

NOTE: Mean Sea Level (MSL) referenced to NAVD88 Datum.

Appendix A

Historical Groundwater Potentiometric Maps

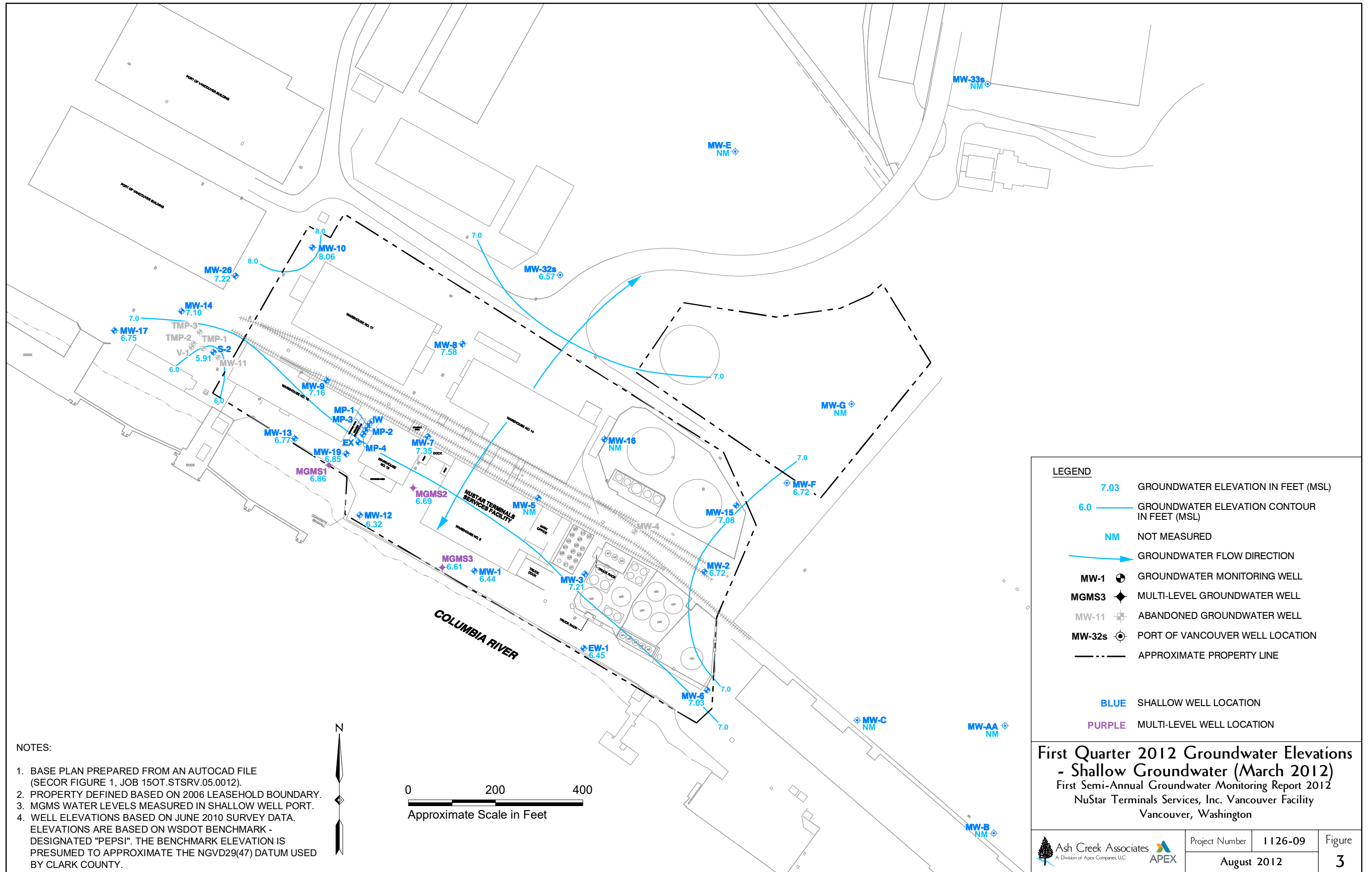

NOTES:

1. BASE PLAN PREPARED FROM AN AUTOCAD FILE (SECOR FIGURE 1, JOB 150T.STSRV.05.0012).
2. PROPERTY DEFINED BASED ON 2006 LEASEHOLD BOUNDARY.
3. MGMS WATER LEVELS MEASURED IN SHALLOW WELL PORT.
4. WELL ELEVATIONS BASED ON JUNE 2010 SURVEY DATA. ELEVATIONS ARE BASED ON WSDOT BENCHMARK - DESIGNATED "PEPSI". THE BENCHMARK ELEVATION IS PRESUMED TO APPROXIMATE THE NGVD29(47) DATUM USED BY CLARK COUNTY.

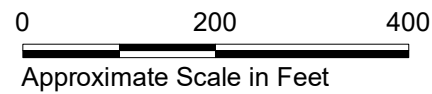

LEGEND

- 7.03 GROUNDWATER ELEVATION IN FEET (MSL)
- 6.0 GROUNDWATER ELEVATION CONTOUR IN FEET (MSL)
- NM NOT MEASURED
- GROUNDWATER FLOW DIRECTION
- MW-1 GROUNDWATER MONITORING WELL
- MGMS3 MULTI-LEVEL GROUNDWATER WELL
- MW-11 ABANDONED GROUNDWATER WELL
- MW-32s PORT OF VANCOUVER WELL LOCATION
- APPROXIMATE PROPERTY LINE
- BLUE SHALLOW WELL LOCATION
- PURPLE MULTI-LEVEL WELL LOCATION

First Quarter 2012 Groundwater Elevations - Shallow Groundwater (March 2012)
 First Semi-Annual Groundwater Monitoring Report 2012
 NuStar Terminals Services, Inc. Vancouver Facility
 Vancouver, Washington

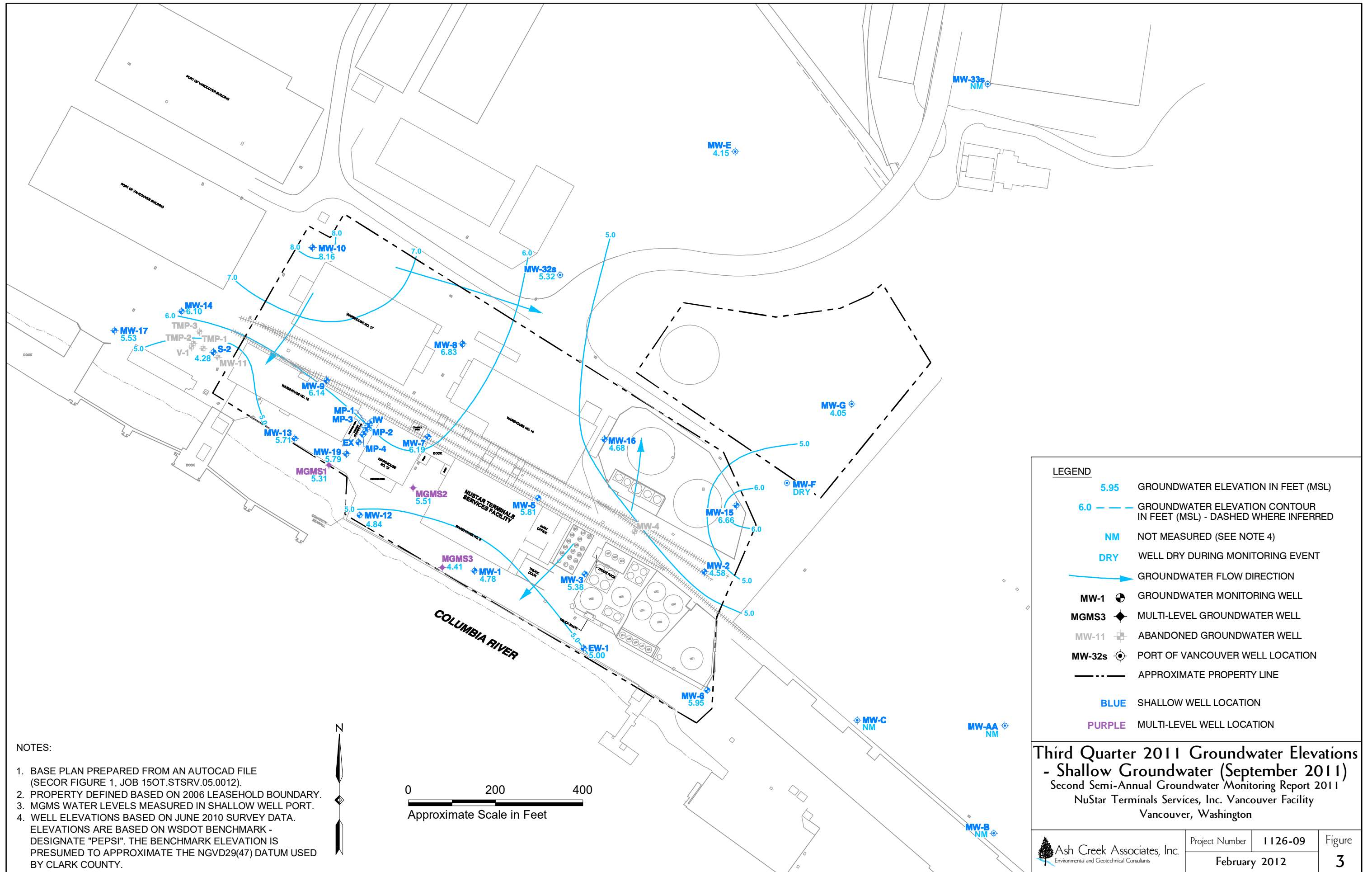

NOTES:

1. BASE PLAN PREPARED FROM AN AUTOCAD FILE (SECOR FIGURE 1, JOB 150T.STSRV.05.0012).
2. PROPERTY DEFINED BASED ON 2006 LEASEHOLD BOUNDARY.
3. MGMS WATER LEVELS MEASURED IN SHALLOW WELL PORT.
4. WELL ELEVATIONS BASED ON JUNE 2010 SURVEY DATA. ELEVATIONS ARE BASED ON WSDOT BENCHMARK - DESIGNATE "PEPSI". THE BENCHMARK ELEVATION IS PRESUMED TO APPROXIMATE THE NGVD29(47) DATUM USED BY CLARK COUNTY.

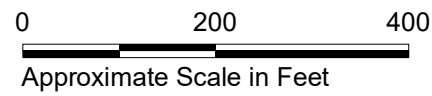

LEGEND

- 5.95 GROUNDWATER ELEVATION IN FEET (MSL)
- 6.0 --- GROUNDWATER ELEVATION CONTOUR IN FEET (MSL) - DASHED WHERE INFERRED
- NM NOT MEASURED (SEE NOTE 4)
- DRY WELL DRY DURING MONITORING EVENT
- GROUNDWATER FLOW DIRECTION
- MW-1 ⊕ GROUNDWATER MONITORING WELL
- MGMS3 ⊕ MULTI-LEVEL GROUNDWATER WELL
- MW-11 ⊕ ABANDONED GROUNDWATER WELL
- MW-32s ⊕ PORT OF VANCOUVER WELL LOCATION
- - - APPROXIMATE PROPERTY LINE
- BLUE SHALLOW WELL LOCATION
- PURPLE MULTI-LEVEL WELL LOCATION

Third Quarter 2011 Groundwater Elevations - Shallow Groundwater (September 2011)
 Second Semi-Annual Groundwater Monitoring Report 2011
 NuStar Terminals Services, Inc. Vancouver Facility
 Vancouver, Washington

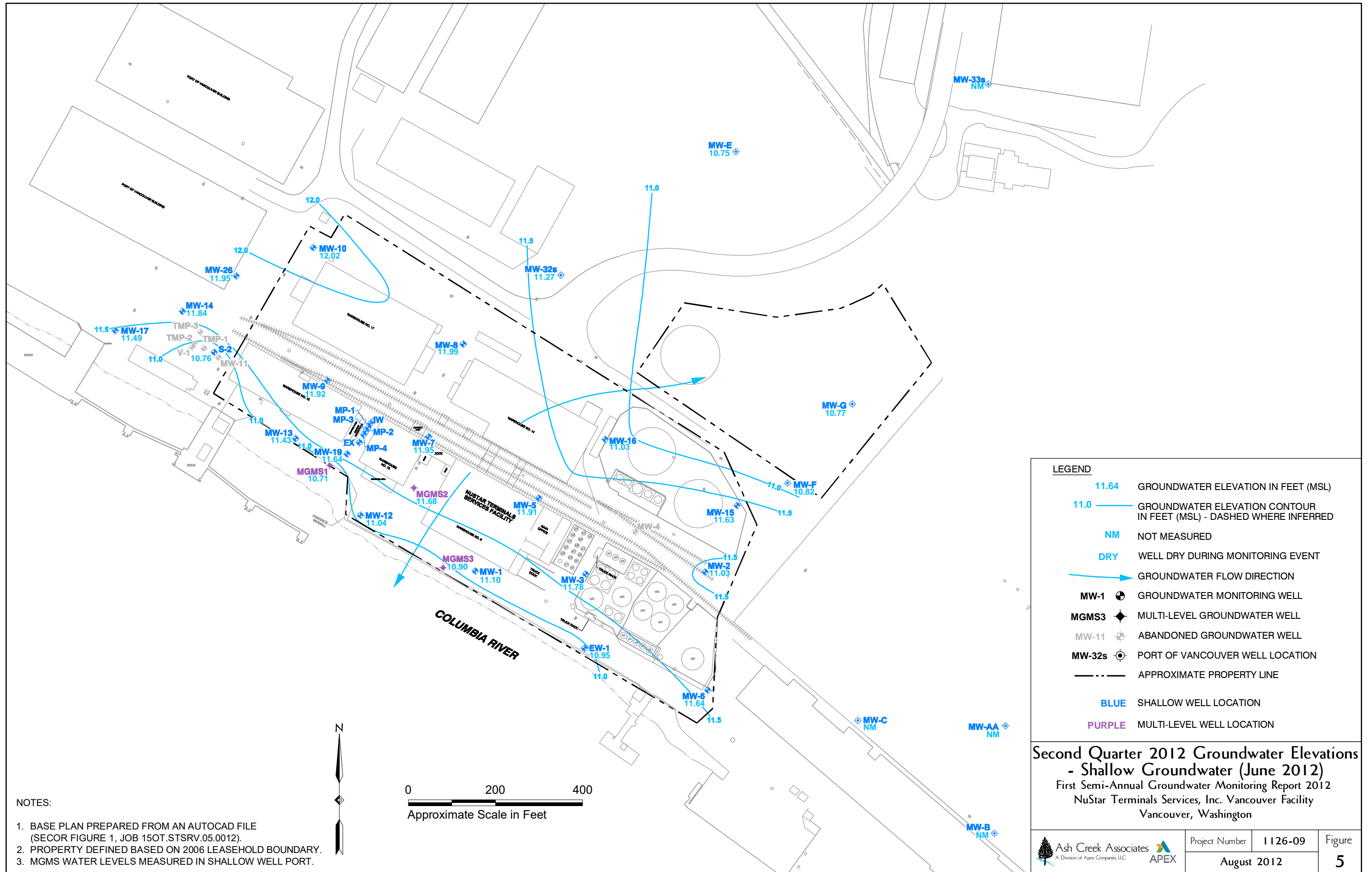

- NOTES:
1. BASE PLAN PREPARED FROM AN AUTOCAD FILE (SECOR FIGURE 1, JOB 150T.STSRV.05.0012).
 2. PROPERTY DEFINED BASED ON 2006 LEASEHOLD BOUNDARY.
 3. MGMS WATER LEVELS MEASURED IN SHALLOW WELL PORT.

LEGEND	
11.64	GROUNDWATER ELEVATION IN FEET (MSL)
11.0	GROUNDWATER ELEVATION CONTOUR IN FEET (MSL) - DASHED WHERE INFERRED
NM	NOT MEASURED
DRY	WELL DRY DURING MONITORING EVENT
→	GROUNDWATER FLOW DIRECTION
MW-1	GROUNDWATER MONITORING WELL
MGMS3	MULTI-LEVEL GROUNDWATER WELL
MW-11	ABANDONED GROUNDWATER WELL
MW-32s	PORT OF VANCOUVER WELL LOCATION
- - -	APPROXIMATE PROPERTY LINE
BLUE	SHALLOW WELL LOCATION
PURPLE	MULTI-LEVEL WELL LOCATION

Second Quarter 2012 Groundwater Elevations - Shallow Groundwater (June 2012)
 First Semi-Annual Groundwater Monitoring Report 2012
 NuStar Terminals Services, Inc. Vancouver Facility
 Vancouver, Washington

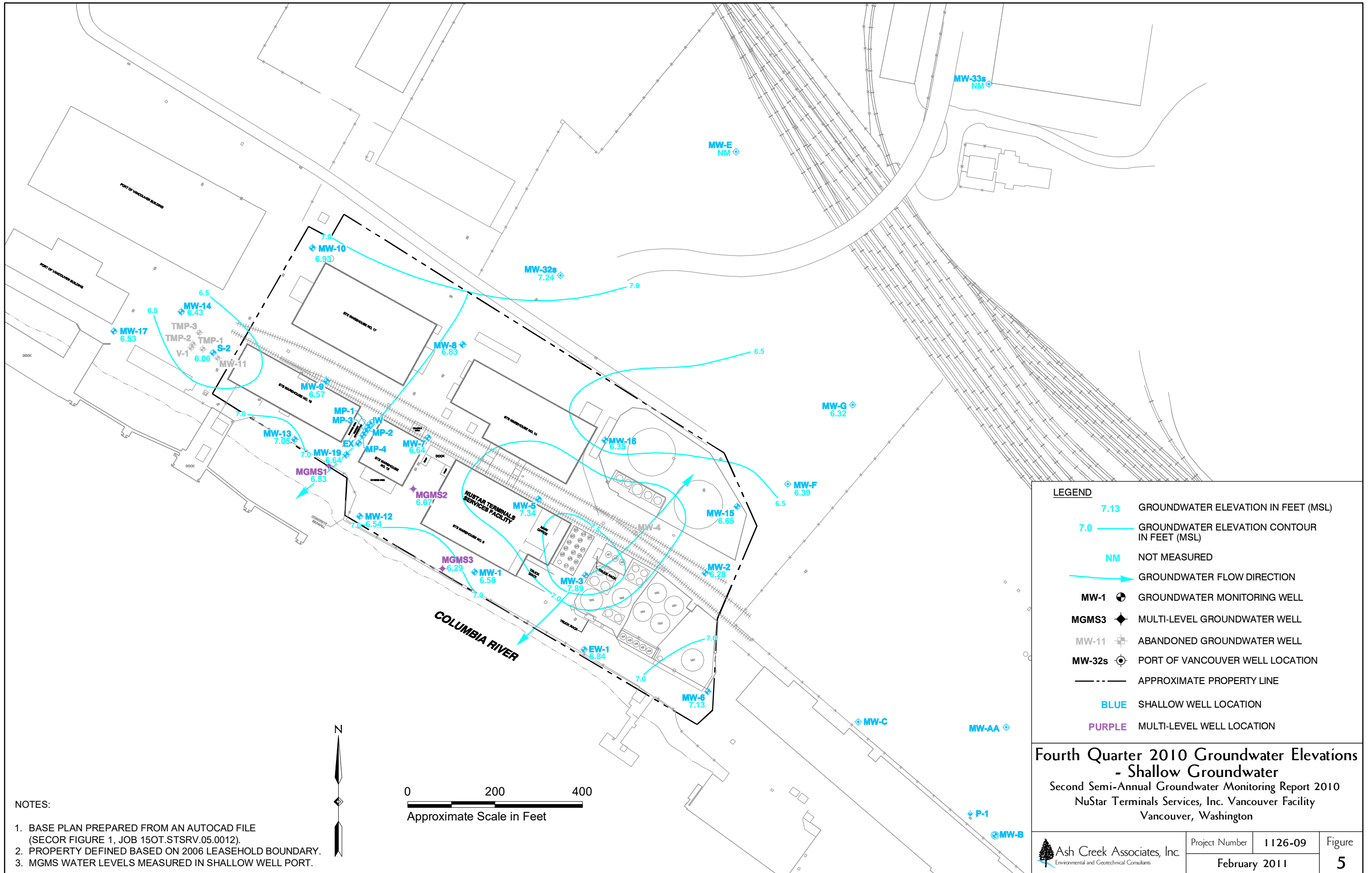

LEGEND

- 7.13 GROUNDWATER ELEVATION IN FEET (MSL)
- 7.0 GROUNDWATER ELEVATION CONTOUR IN FEET (MSL)
- NM NOT MEASURED
- GROUNDWATER FLOW DIRECTION
- MW-1 GROUNDWATER MONITORING WELL
- MGMS3 MULTI-LEVEL GROUNDWATER WELL
- MW-11 ABANDONED GROUNDWATER WELL
- MW-32s PORT OF VANCOUVER WELL LOCATION
- APPROXIMATE PROPERTY LINE
- BLUE SHALLOW WELL LOCATION
- PURPLE MULTI-LEVEL WELL LOCATION

Fourth Quarter 2010 Groundwater Elevations - Shallow Groundwater
 Second Semi-Annual Groundwater Monitoring Report 2010
 NuStar Terminals Services, Inc. Vancouver Facility
 Vancouver, Washington

- NOTES:
1. BASE PLAN PREPARED FROM AN AUTOCAD FILE (SECOR FIGURE 1, JOB 150T.STSRV.05.0012).
 2. PROPERTY DEFINED BASED ON 2006 LEASEHOLD BOUNDARY.
 3. MGMS WATER LEVELS MEASURED IN SHALLOW WELL PORT.

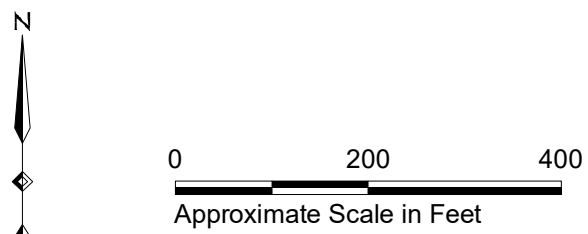

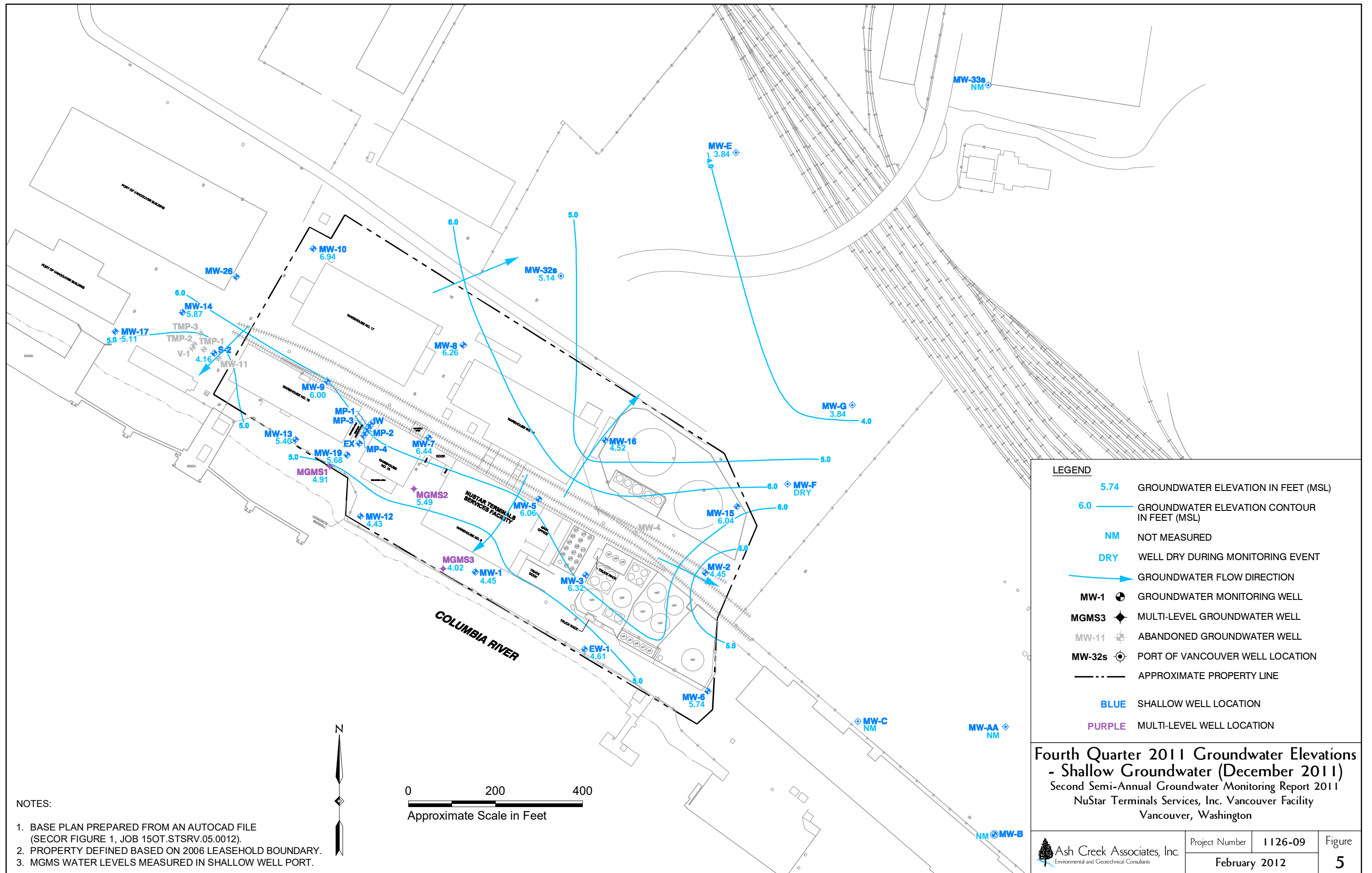

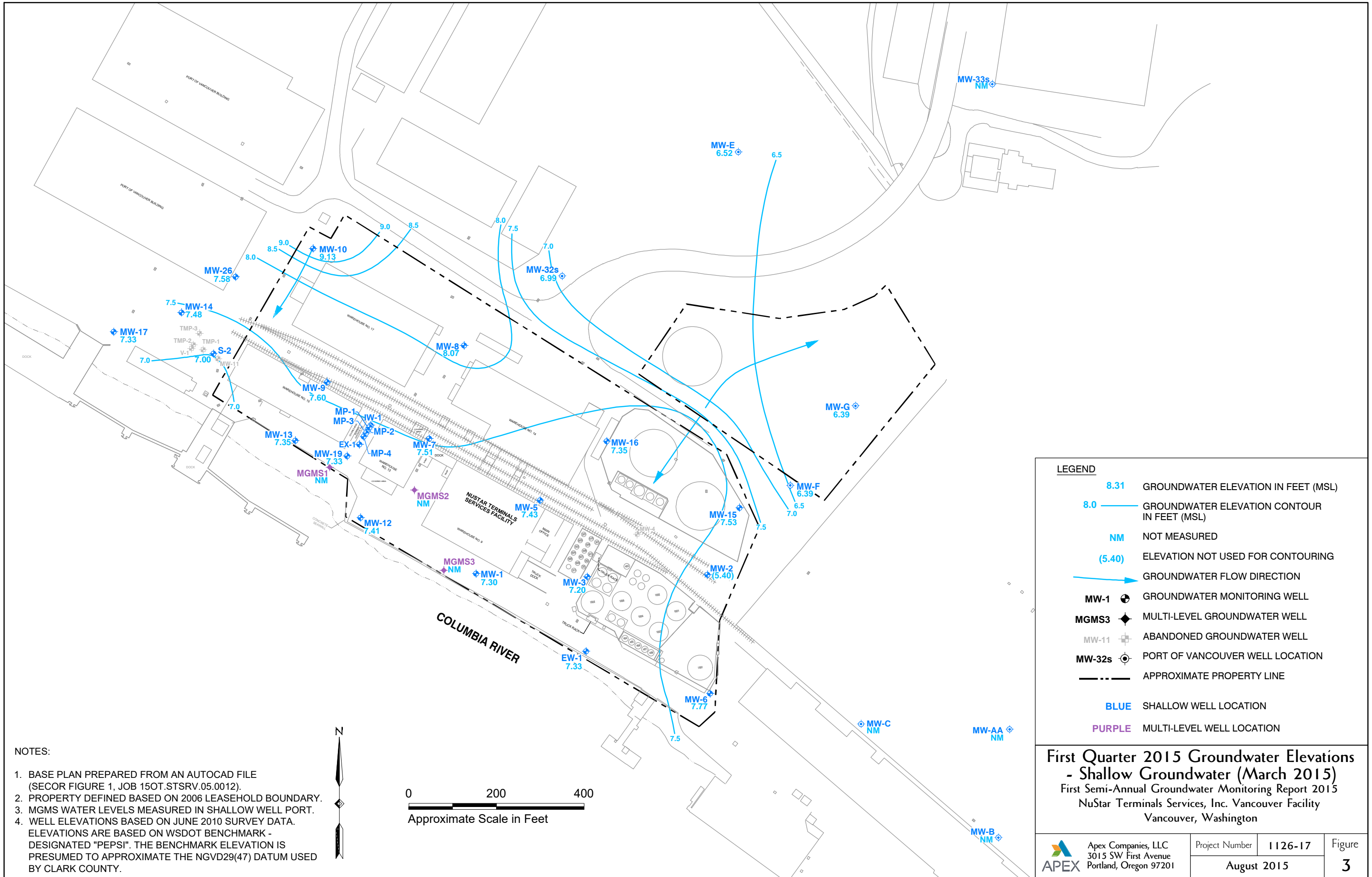

LEGEND

- 8.31 GROUNDWATER ELEVATION IN FEET (MSL)
- 8.0 GROUNDWATER ELEVATION CONTOUR IN FEET (MSL)
- NM NOT MEASURED
- (5.40) ELEVATION NOT USED FOR CONTOURING
- GROUNDWATER FLOW DIRECTION
- MW-1 GROUNDWATER MONITORING WELL
- MGMS3 MULTI-LEVEL GROUNDWATER WELL
- MW-11 ABANDONED GROUNDWATER WELL
- MW-32s PORT OF VANCOUVER WELL LOCATION
- APPROXIMATE PROPERTY LINE
- BLUE SHALLOW WELL LOCATION
- PURPLE MULTI-LEVEL WELL LOCATION

First Quarter 2015 Groundwater Elevations - Shallow Groundwater (March 2015)
 First Semi-Annual Groundwater Monitoring Report 2015
 NuStar Terminals Services, Inc. Vancouver Facility
 Vancouver, Washington

NOTES:

1. BASE PLAN PREPARED FROM AN AUTOCAD FILE (SECOR FIGURE 1, JOB 15OT.STSRV.05.0012).
2. PROPERTY DEFINED BASED ON 2006 LEASEHOLD BOUNDARY.
3. MGMS WATER LEVELS MEASURED IN SHALLOW WELL PORT.
4. WELL ELEVATIONS BASED ON JUNE 2010 SURVEY DATA. ELEVATIONS ARE BASED ON WSDOT BENCHMARK - DESIGNATED "PEPSI". THE BENCHMARK ELEVATION IS PRESUMED TO APPROXIMATE THE NGVD29(47) DATUM USED BY CLARK COUNTY.

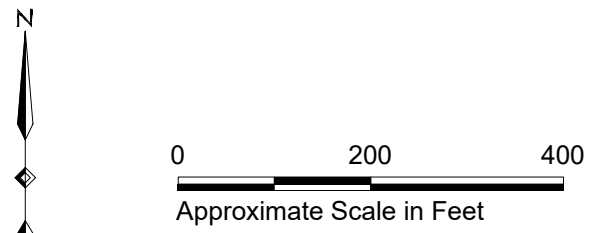

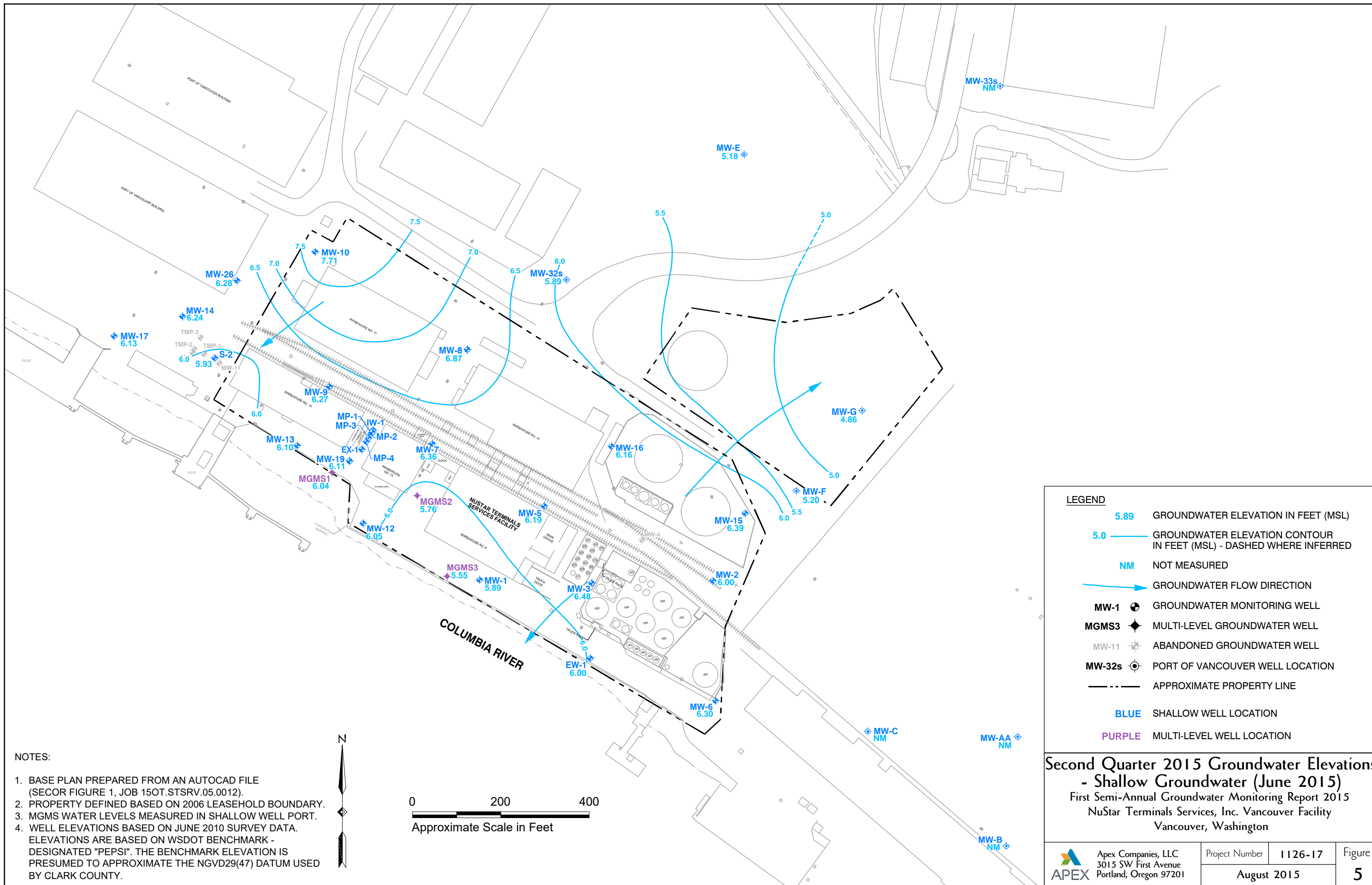

LEGEND

- 5.89 GROUNDWATER ELEVATION IN FEET (MSL)
- 5.0 GROUNDWATER ELEVATION CONTOUR IN FEET (MSL) - DASHED WHERE INFERRED
- NM NOT MEASURED
- GROUNDWATER FLOW DIRECTION
- MW-1 GROUNDWATER MONITORING WELL
- MGMS3 MULTI-LEVEL GROUNDWATER WELL
- MW-11 ABANDONED GROUNDWATER WELL
- MW-32s PORT OF VANCOUVER WELL LOCATION
- APPROXIMATE PROPERTY LINE
- BLUE SHALLOW WELL LOCATION
- PURPLE MULTI-LEVEL WELL LOCATION

Second Quarter 2015 Groundwater Elevations - Shallow Groundwater (June 2015)
 First Semi-Annual Groundwater Monitoring Report 2015
 NuStar Terminals Services, Inc. Vancouver Facility
 Vancouver, Washington

- NOTES:**
1. BASE PLAN PREPARED FROM AN AUTOCAD FILE (SECOR FIGURE 1, JOB 150T.STSRV.05.0012).
 2. PROPERTY DEFINED BASED ON 2006 LEASEHOLD BOUNDARY.
 3. MGMS WATER LEVELS MEASURED IN SHALLOW WELL PORT.
 4. WELL ELEVATIONS BASED ON JUNE 2010 SURVEY DATA. ELEVATIONS ARE BASED ON WSDOT BENCHMARK - DESIGNATED "PEPSI". THE BENCHMARK ELEVATION IS PRESUMED TO APPROXIMATE THE NGVD29(47) DATUM USED BY CLARK COUNTY.

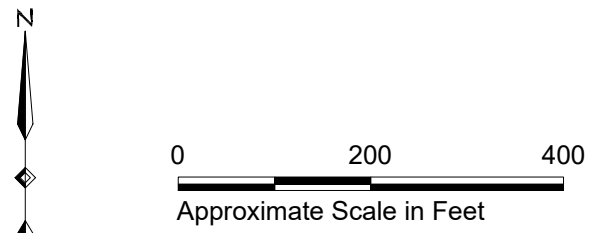

Appendix B

Bioremediation Design

Design Summary: Input parameters for the volume estimate are outlined below. When a parameter was unknown with no laboratory or field information provided by the client, a default value was used. A safety factor of 2 is used in our calculations. If your assumptions are different from those included in this table, or you obtain more information following a pilot test, please let us provide another estimate as the product(s) or volume proposed for this site could change.

Treatment Type	Value	Units	Default	Site Value
Barrier or Source Treatment	Source Area			
EOS Product	EOS Pro			
Length of treatment area parallel to groundwater flow, "x"	75	ft		√
Width of treatment area perpendicular to groundwater flow, "y"	290	ft		√
Treatment thickness, "z"	20	ft		√
Nominal soil type	Sand			√
Estimated Porosity (total)	0.38			√
Effective Porosity	0.23			√
Soil bulk density	103	pcf	Calculated	
Biogeochemical				
pH of groundwater	7.00	SU		√
Acid demand of aquifer material	0.0	OH ⁻ meq/Kg		√
Acidity of groundwater	0.0	OH ⁻ meq/L		√
Acidity values based on laboratory data	No			
Geohydrology				
Hydraulic Conductivity	90	ft/d		√
Hydraulic Gradient	0.0025	ft/ft		√
Seepage Velocity	0.978	ft/d	Calculated	
Contact time	60	days	√	
Design Life per application	3	yrs.	√	
Analytical				
Dissolved Oxygen (DO)	1	mg/L		√
Nitrate Nitrogen (NO ₃ ⁻ - N)	60	mg/L		√
Sulfate (SO ₄ ²⁻)	70	mg/L		√
Tetrachloroethene (PCE), C ₂ Cl ₄	0.3	mg/L		√
Trichloroethene (TCE), C ₂ HCl ₃	0.9	mg/L		√
cis-1,2-dichloroethene (c-DCE), C ₂ H ₂ Cl ₂	0	mg/L		√
Vinyl Chloride (VC), C ₂ H ₃ Cl	0	mg/L		√
Carbon tetrachloride, CCl ₄	0	mg/L		√
Chloroform, CHCl ₃	0	mg/L		√
sym-tetrachloroethane, C ₂ H ₂ Cl ₄	0	mg/L		√
1,1,1-Trichloroethane (TCA), CH ₃ CCl ₃	0	mg/L		√
1,1-Dichloroethane (DCA), C ₂ H ₄ Cl ₂	0	mg/L		√
Chloroethane, C ₂ H ₅ Cl	0	mg/L		√
Perchlorate, ClO ₄ ⁻	0	mg/L		√
Hexavalent Chromium, Cr[VI]	0	mg/L		√
Pentachlorophenol	0	mg/L		√
User added	0	mg/L		
User added	0	mg/L		
Design				
Design Factor	1.5	times	√	
Stoichiometric Hydrogen Demand	2439.9	lbs	Calculated	
Effective treatment thickness for substrate, "z _e "	25%		√	
Absorptive Capacity of soil	0.0012		√	
Substrate from hydrogen demand	37452	lbs	Calculated	
Substrate required from Adsorption	22383	lbs	Calculated	
DOC Released	27665	lbs	Calculated	
Estimated Amount of Fe ²⁺ Formed	10	mg/L	√	
Estimated Amount of Manganese (Mn ²⁺) Formed	5	mg/L	√	
Estimated Amount of CH ₄ Formed	10	mg/L	√	
Target Amount of DOC to Release	100	mg/L	√	
Effective treatment thickness for buffer, "z _b "	25%		√	
Base Required for Sediment	0	OH ⁻ eq	Calculated	
Base Required for Aquifer	0	OH ⁻ eq	Calculated	
Mass to be treated	11,154,394	lbs	Calculated	
Estimated total groundwater volume treated over design life	11,926,004	gal	Calculated	
Calculated Substrate Requirement				
Substrate Requirement Based on Hydrogen Demand and Carbon Loss	37,452	lbs		
Substrate Requirement Based on Oil Entrapment by Aquifer Material	22,383	lbs		
EOS Pro Requirement			90	Drums
CoBupHMg Requirement	0	lbs	0.0	Pails
Quantity of Dechlorinating Consortium	703	L		

Please note that EOS Remediation, LLC offers a family of highly-acclaimed bioremediation products that are licensed under various patented methods for bioremediation. Product sheets, brochures, instructions, technical advice, suggested recommendations by our staff, or other information provided by EOS Remediation is provided as guidelines for the convenience of Buyer only and should not be construed as a substitute for appropriate engineering and geologic design by qualified professionals. We are not a professional engineering firm and do not provide professional advice. Soil and other environmental conditions vary and requirements for use and the effectiveness of our products will vary according to the specific circumstances. Our products may not be suitable for some applications.

Design Summary: Input parameters for the volume estimate are outlined below. When a parameter was unknown with no laboratory or field information provided by the client, a default value was used. A safety factor of 2 is used in our calculations. If your assumptions are different from those included in this table, or you obtain more information following a pilot test, please let us provide another estimate as the product(s) or volume proposed for this site could change.

Treatment Type	Value	Units	Default	Site Value
Barrier or Source Treatment	Source Area			
EOS Product	EOS Pro			
Length of treatment area parallel to groundwater flow, "x"	80	ft		√
Width of treatment area perpendicular to groundwater flow, "y"	480	ft		√
Treatment thickness, "z"	20	ft		√
Nominal soil type	Sand			√
Estimated Porosity (total)	0.38			√
Effective Porosity	0.23			√
Soil bulk density	103	pcf	Calculated	
Biogeochemical				
pH of groundwater	7.00	SU		√
Acid demand of aquifer material	0.0	OH ⁻ meq/Kg		√
Acidity of groundwater	0.0	OH ⁻ meq/L		√
Acidity values based on laboratory data	No			
Geohydrology				
Hydraulic Conductivity	90	ft/d		√
Hydraulic Gradient	0.0025	ft/ft		√
Seepage Velocity	0.978	ft/d	Calculated	
Contact time	60	days	√	
Design Life per application	3	yrs.	√	
Analytical				
Dissolved Oxygen (DO)	1	mg/L		√
Nitrate Nitrogen (NO ₃ ⁻ - N)	79	mg/L		√
Sulfate (SO ₄ ²⁻)	89	mg/L		√
Tetrachloroethene (PCE), C ₂ Cl ₄	1.5	mg/L		√
Trichloroethene (TCE), C ₂ HCl ₃	1	mg/L		√
cis-1,2-dichloroethene (c-DCE), C ₂ H ₂ Cl ₂	1.5	mg/L		√
Vinyl Chloride (VC), C ₂ H ₃ Cl	0	mg/L		√
Carbon tetrachloride, CCl ₄	0	mg/L		√
Chloroform, CHCl ₃	0	mg/L		√
sym-tetrachloroethane, C ₂ H ₂ Cl ₄	0	mg/L		√
1,1,1-Trichloroethane (TCA), CH ₃ CCl ₃	0	mg/L		√
1,1-Dichloroethane (DCA), C ₂ H ₄ Cl ₂	0	mg/L		√
Chloroethane, C ₂ H ₅ Cl	0	mg/L		√
Perchlorate, ClO ₄ ⁻	0	mg/L		√
Hexavalent Chromium, Cr[VI]	0	mg/L		√
Pentachlorophenol	0	mg/L		√
User added	0	mg/L		
User added	0	mg/L		
Design				
Design Factor	1.5	times	√	
Stoichiometric Hydrogen Demand	4890.0	lbs	Calculated	
Effective treatment thickness for substrate, "z _e "	25%		√	
Absorptive Capacity of soil	0.0012		√	
Substrate from hydrogen demand	65721	lbs	Calculated	
Substrate required from Adsorption	39518	lbs	Calculated	
DOC Released	46107	lbs	Calculated	
Estimated Amount of Fe ²⁺ Formed	10	mg/L	√	
Estimated Amount of Manganese (Mn ²⁺) Formed	5	mg/L	√	
Estimated Amount of CH ₄ Formed	10	mg/L	√	
Target Amount of DOC to Release	100	mg/L	√	
Effective treatment thickness for buffer, "z _b "	25%		√	
Base Required for Sediment	0	OH ⁻ eq	Calculated	
Base Required for Aquifer	0	OH ⁻ eq	Calculated	
Mass to be treated	19,693,275	lbs	Calculated	
Estimated total groundwater volume treated over design life	19,876,038	gal	Calculated	
Calculated Substrate Requirement				
Substrate Requirement Based on Hydrogen Demand and Carbon Loss	65,721	lbs		
Substrate Requirement Based on Oil Entrapment by Aquifer Material	39,518	lbs		
EOS Pro Requirement			157	Drums
CoBupHMg Requirement	0	lbs	0.0	Pails
Quantity of Dechlorinating Consortium	703	L		

Please note that EOS Remediation, LLC offers a family of highly-acclaimed bioremediation products that are licensed under various patented methods for bioremediation. Product sheets, brochures, instructions, technical advice, suggested recommendations by our staff, or other information provided by EOS Remediation is provided as guidelines for the convenience of Buyer only and should not be construed as a substitute for appropriate engineering and geologic design by qualified professionals. We are not a professional engineering firm and do not provide professional advice. Soil and other environmental conditions vary and requirements for use and the effectiveness of our products will vary according to the specific circumstances. Our products may not be suitable for some applications.

Section 1: Identification	
Product Name:	EOS Pro
Chemical Description:	Mixture; vegetable oil emulsion
Manufacturer:	EOS Remediation 1101 Nowell Road Raleigh, NC 27607 (P): 919-873-2204 www.eosremediation.com
Recommended Use:	Groundwater bioremediation (environmental applications)
Restricted Use:	Not for human consumption.
24-Hour Emergency Contact:	ChemTel: United States (P): 800-255-3924 ChemTel: International (P): 813-248-0585

Section 2: Hazard(s) Identification	
Hazard Classification:	Irritant (skin and eye)
Signal Word:	Warning
Hazard Statement(s):	Potential eye and skin irritant.
Pictograms:	
Precautionary Statement(s):	Not for human consumption. Do not store near excessive heat or oxidizers. Avoid contact with eyes and skin. Wear protective gloves and eye protection.

Section 3: Composition/Information on Ingredients		
Common Name(s)	CAS NO.	% by Weight
Soybean Oil	8001-22-7	59.8
Food Grade Emulsifiers Trade Secret ^{1,2}	Proprietary	10
Soluble Substrates Trade Secret ^{1,2}	Proprietary	4
Food Additives/Preservatives Trade Secret ¹	Proprietary	0.3
Nutrients/Extracts Trade Secret ^{1,2}	Proprietary	1
Water	7732-18-5	Balance

1 – The precise composition of this product is proprietary information. A more complete disclosure will be provided to a physician in the event of a medical emergency.

2 – The soluble substrates and emulsifiers are generally recognized as safe for food contact.

Section 4: First-Aid Measures	
Routes of Exposure	Emergency First-Aid Procedures
Inhalation	Remove to fresh air.
Eye Contact	Flush with water for 15 minutes; if irritation persists see a physician.
Skin Contact	Wash with mild soap and water.
Ingestion	Product is non-toxic. If nausea occurs, induce vomiting and seek medical attention.

Section 5: Fire-Fighting Measures	
Extinguishing Media:	CO ₂ , foam, dry chemical Note: Water, fog and foam may cause frothing and spattering.
Special Fire Fighting Procedures:	Wear self-contained breathing apparatus and chemical resistant clothing. Use water spray to cool fire exposed containers.
Fire Hazard(s):	Burning will cause oxides of carbon.

Section 6: Accidental Release Measures	
Personal Precautions:	Avoid contact with eyes and skin. Do not consume.
Emergency Procedures:	N/A
Methods & Materials used for Containment:	Compatible granular absorbent
Cleanup Procedures:	Spread compatible granular absorbent over spill area and sweep using broom and pan; dispose in appropriate receptacle. Clean area with water.

Section 7: Handling and Storage	
Safe Handling & Storage:	Do not store near excessive heat or oxidizers.
Other Precautions:	Consumption of food and beverages should be prevented in work area where product is being used. After handling product, always wash hands and face thoroughly with soap and water before eating, drinking, or smoking.

Section 8: Exposure Controls/Personal Protection		
Exposure Limits		
OSHA PEL:	NE	
ACGIH TLV:	NE	
NIOSH REL:	NE	
Personal Protective Measures		
Respiratory Protection:	Not normally required. P95 respirator if aerosols might be generated.	
Hand Protection:	Protective gloves are recommended	
Eye Protection:	Recommended	
Engineering Measures:	Local exhaust ventilation if aerosols are generated	
Hygiene Measures:	Wash promptly with soap & water if skin becomes irritated from contact.	
Other Protection:	Wear appropriate clothing to prevent skin contact.	

Section 9: Physical and Chemical Properties

Appearance:	White Liquid	Explosive Limits:	NE
Odor:	Vegetable Oil	Vapor Pressure:	NE
Odor Threshold:	NE	Vapor Density:	Heavier than air
pH:	Neutral	Relative Density:	0.96-0.98
Melting Point/Freezing Point:	Liquid at room temperature	Solubility:	Dispersible
Boiling Point:	212°F (100°C)	Partition coefficient:	NE
Flash Point:	>300°F (149°C)	Auto-ignition Temperature:	NE
Evaporation Rate:	NE	Decomposition Temperature:	N/A
Flammability (solid, gas):	NE	Viscosity:	500-1500 cP

NE – Not Established

Section 10: Stability and Reactivity

Stability:	Stable
Incompatibility:	Strong acids and oxidizers
Hazardous Decomposition Products:	Thermal decomposition may produce oxides of carbon
Hazardous Reactions/Polymerization:	Will not occur
Conditions to Avoid:	None known

Section 11: Toxicological Information

Likely Routes of Exposure:	Ingestion, dermal and eye contact
Signs and Symptoms of Exposure:	None known
Health Hazards	
Acute:	Potential eye and skin irritant
Chronic:	None known
Carcinogenicity	
NTP:	No
IARC:	No
OSHA:	No

Section 12: Ecological Information (non-mandatory)

There is no data on the ecotoxicity of this product.

Section 13: Disposal Considerations (non-mandatory)

Waste Disposal Methods:	Dispose of according to Federal and local regulations for non-hazardous waste. Recycle, if practical.
-------------------------	---

Section 14: Transport Information (non-mandatory)

The product is not covered by international regulation on the transport of dangerous goods.

No transport warning required.

Section 15: Regulatory Information (non-mandatory)

N/A

Section 16: Other Information

Date of Preparation:	29 May 2014
----------------------	-------------

Last Modified Date:	5 September 2014
---------------------	------------------

The information contained herein is based on available data and is believed to be correct. However, EOS Remediation, LLC makes no warranty, expressed or implied, regarding the accuracy of this data or the results to be obtained thereof. This information and product are furnished on the condition that the person receiving them shall make his/her own determination as to the suitability of the product for his/her particular purpose.

Appendix C

POV Bathymetry and Seawall Structure Maps

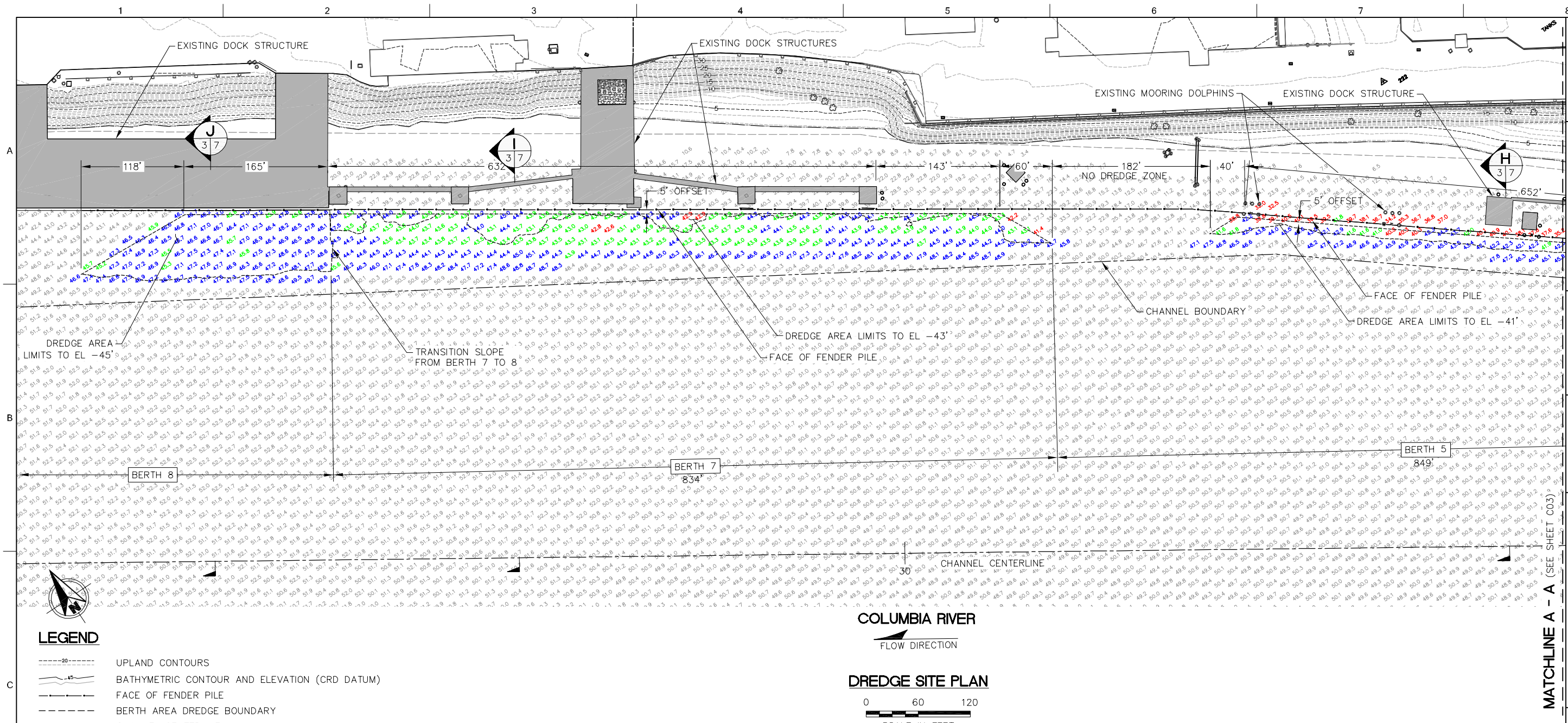

LEGEND

- 20--- UPLAND CONTOURS
- 45--- BATHYMETRIC CONTOUR AND ELEVATION (CRD DATUM)
- FACE OF FENDER PILE
- BERTH AREA DREDGE BOUNDARY
- CHANNEL CENTERLINE
- CHANNEL BOUNDARY
- 105 RIVER MILE MARKER
- A X X SECTION CALLOUT

HYDROGRAPHIC SOUND POINT DEFINITIONS:

BERTH 8		
ABOVE GRADE	ALLOWABLE OVERDEPTH	BELOW OVERDEPTH
-44.3	-45.5	-45.5
BERTH 7		
ABOVE GRADE	ALLOWABLE OVERDEPTH	BELOW OVERDEPTH
-42.6	-43.8	-45.5
BERTH 5		
ABOVE GRADE	ALLOWABLE OVERDEPTH	BELOW OVERDEPTH
-40.2	-41.3	-43.2

HYDROGRAPHIC SURVEY NOTES:

BATHYMETRIC SURVEY SHOWN BY ETRAC DATED FEBRUARY 1, 2011.
 HORIZONTAL DATUM: WASHINGTON STATE PLANE SOUTH, NAD83 (US FEET)
 VERTICAL DATUM: COLUMBIA RIVER DATUM (CRD), FEET.

NOTE:

1. ALL HYDROGRAPHIC SOUNDING DATA POINTS REPORTED AS DEPTHS BELOW CRD 0.0 FEET.

AS-BUILT



COAST & HARBOR ENGINEERING, INC.
 110 MAIN STREET, SUITE 103
 EDMONDS, WA 98020
 PH 425-778-2542
 FAX 425-778-6883

DRAWING SCALE:
60
DRAWN BY:
TM
APPROVED BY:
SP
DATE:
2/9/11

REVISION NO. DATE:
POST DREDGE CONDITION:
 2/9/11

SITE PLAN
MAINTENANCE DREDGING/ BERTH DEEPENING

VANCOUVER U.S.A.
PORT OF VANCOUVER
 3103 N.W. LOWER RIVER ROAD
 VANCOUVER, WA 98660-1027
 (360) 693-3611 FAX (360) 735-1565

SHEET CONTENTS
 LOCATION OF THE REAL DWG TITLE
DRAWING NUMBER
C-02
 SHEET NUMBER 3 OF 12
 POV PROJECT NO:
CP 0190

A/E PROJECT NUMBER: 0405

MATCHLINE A - A (SEE SHEET C03)

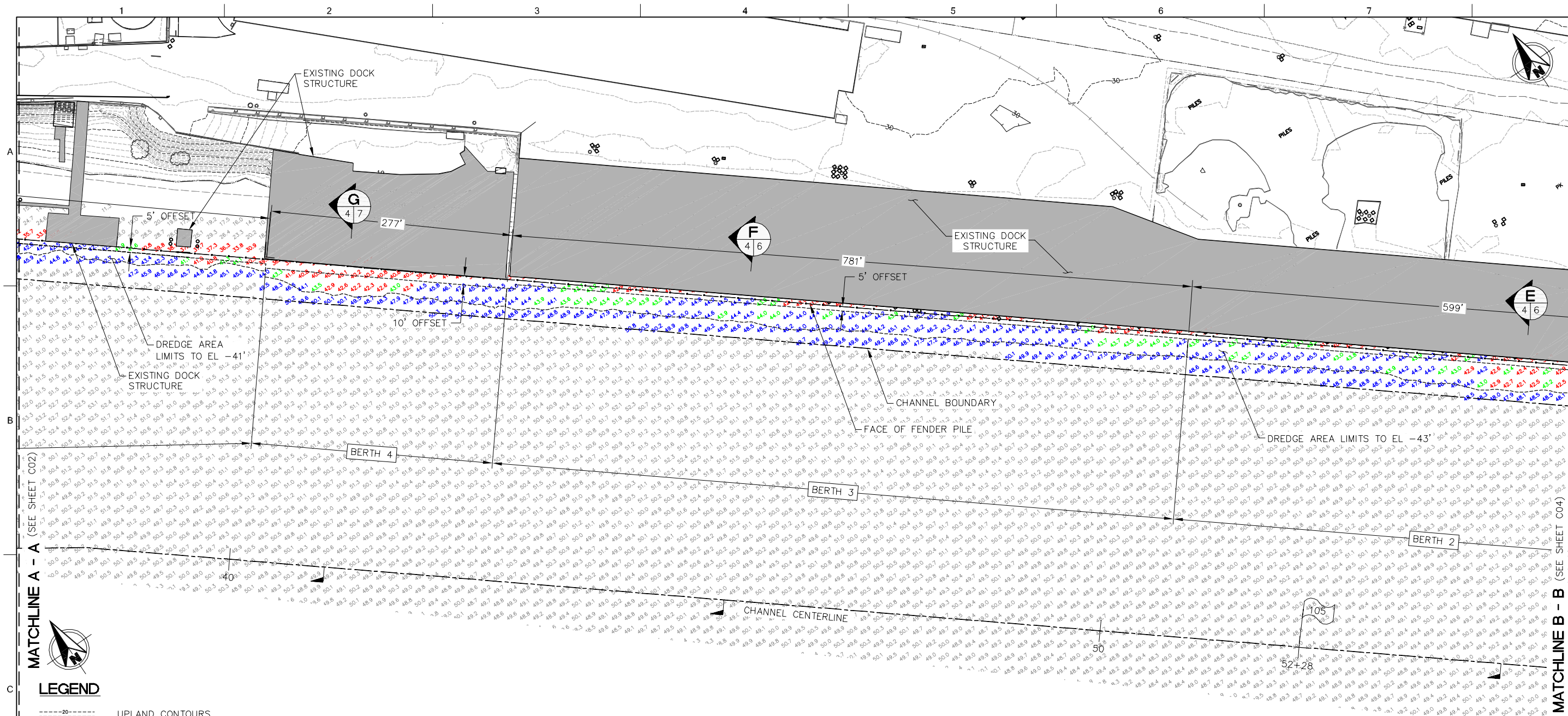

MATCHLINE A - A (SEE SHEET C02)

MATCHLINE B - B (SEE SHEET C04)

- LEGEND**
- UPLAND CONTOURS
 - BATHYMETRIC CONTOUR AND ELEVATION (CRD DATUM)
 - FACE OF FENDER PILE
 - BERTH AREA DREDGE BOUNDARY
 - CHANNEL CENTERLINE
 - CHANNEL BOUNDARY
 - RIVER MILE MARKER
 - SECTION CALLOUT

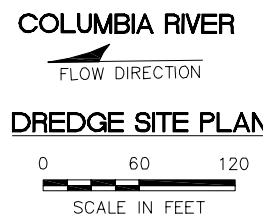

HYDROGRAPHIC SOUND POINT DEFINITIONS:

BERTH 5		
ABOVE GRADE	ALLOWABLE OVERDEPTH	BELOW OVERDEPTH
-40.2	-41.3	-43.2

BERTHS 2, 3 AND 4		
ABOVE GRADE	ALLOWABLE OVERDEPTH	BELOW OVERDEPTH
-41.5	-43.4	-45.3

HYDROGRAPHIC SURVEY NOTES:

BATHYMETRIC SURVEY SHOWN BY ETRAC DATED FEBRUARY 1, 2011.

HORIZONTAL DATUM: WASHINGTON STATE PLANE SOUTH, NAD83 (US FEET)

VERTICAL DATUM: COLUMBIA RIVER DATUM (CRD), FEET.

AS-BUILT

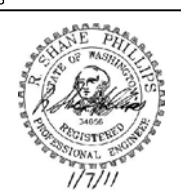

COAST & HARBOR ENGINEERING
 110 MAIN STREET, SUITE 103
 EDMONDS, WA 98020
 PH 425-778-2542
 FAX 425-778-6883

DRAWING SCALE: 60
 DRAWN BY: TM
 APPROVED BY: SP
 DATE: 2/9/11

REVISION NO. DATE.
 POST DREDGE CONDITION
 2/9/11

SITE PLAN

**MAINTENANCE DREDGING/
BERTH DEEPENING**

VANCOUVER U.S.A.
 3103 N.W. LOWER RIVER ROAD
 VANCOUVER, WA 98660-1027
 (360) 693-3611 FAX (360) 735-1565

SHEET CONTENTS

LOCATION OF THE REAL DWG TITLE

DRAWING NUMBER
C-03
 SHEET NUMBER 4 OF 12
 POV PROJECT NO:
CP 0190

A/E PROJECT NUMBER: 0405

TERMINAL 2 SEAWALL (BERTH 5 TO 7) STRENGTHENING

APRIL 2003

SHEET NO. DESCRIPTION

- S1 VICINITY MAP, SITE PLAN, LEGAL DESCRIPTION AND SHEET INDEX
- S2 STRUCTURAL NOTES AND ABBREVIATIONS
- S3 SEAWALL PLANS
- S4 SEAWALL ELEVATIONS
- S5 SECTIONS & DETAILS

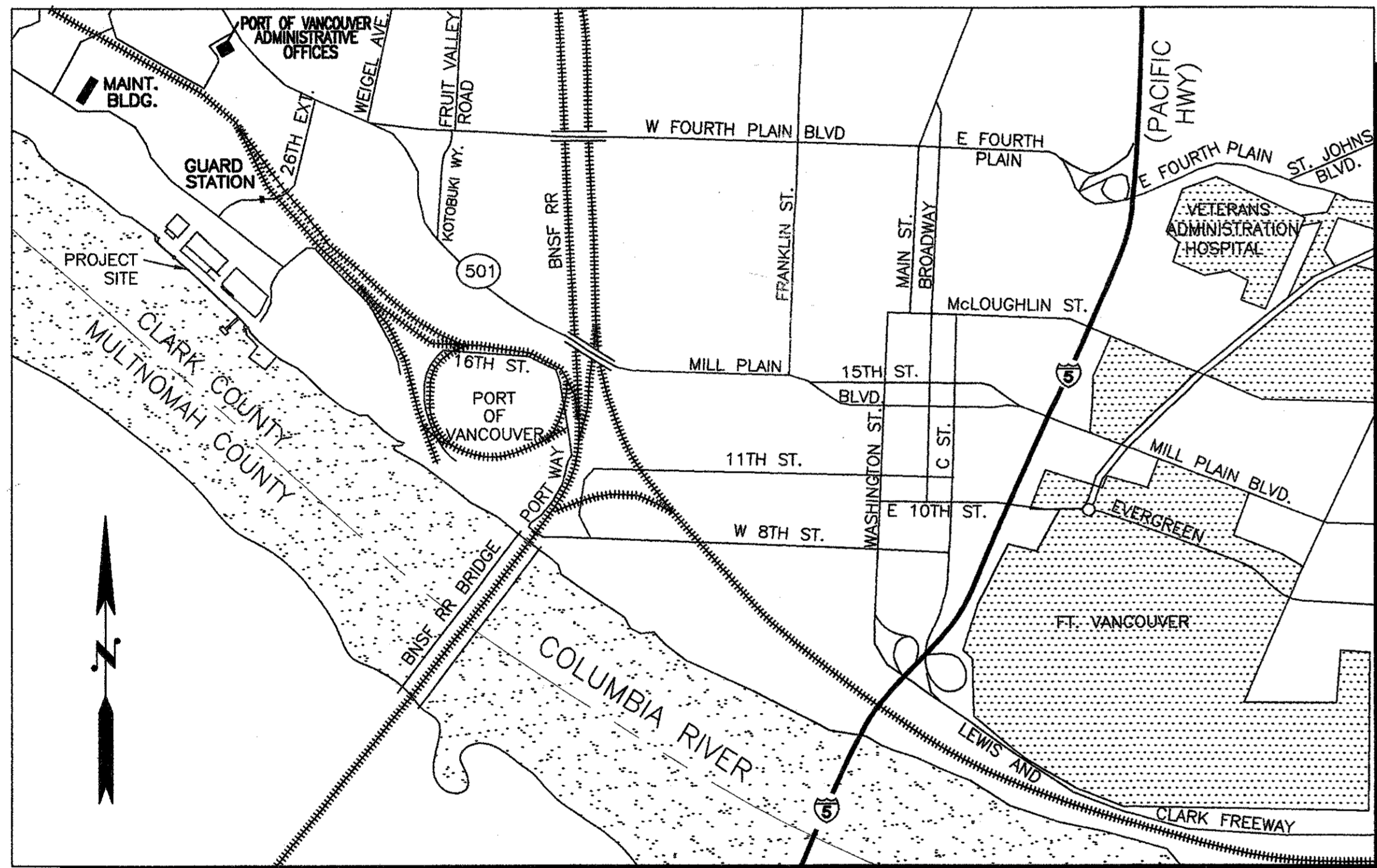

VICINITY MAP

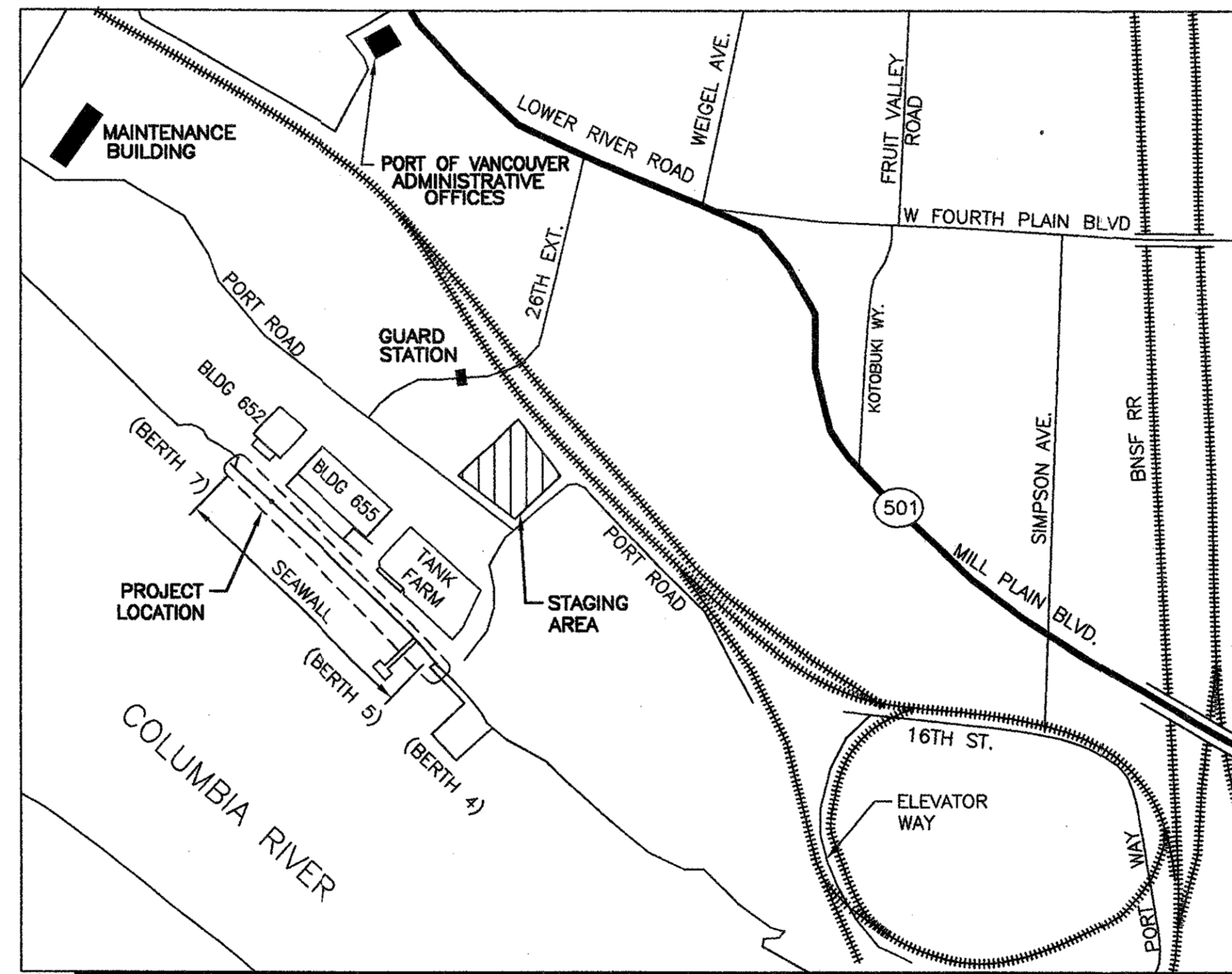

SITE PLAN

**SPECIAL INSPECTIONS
AND STRUCTURAL
OBSERVATIONS REQD
SEE SHEET # S2**

PORT COMMISSIONERS

TOM BRADLEY
ARCH J. MILLER
ROBERT J. MOSER

PORT EXECUTIVE DIRECTOR

LARRY PAULSON

ADDRESS:

TERMINAL 2 - LIQUID BULK FACILITY
PORT OF VANCOUVER
3103 LOWER RIVER ROAD
VANCOUVER, WA 98660

LEGAL:

NW 1/4 OF SECTION 28, T2N, R1E
WILLAMETTE MERIDIAN
TAX LOT: 00022
CLARK COUNTY, WA

PROJECT DESCRIPTION

THE ADDITION OF HORIZONTAL STEEL WALES AND TIEBACK ANCHORS TO EXISTING CONCRETE SEAWALL TO REPLACE THE EXISTING WALL TIEBAR RESTRAINT SYSTEM DUE TO OBSERVED DETERIORATION OF TIEBAR CONNECTION.

CITY OF VANCOUVER
ZONING APPROVAL

JUN 11 2003
BY: *[Signature]*
DEVELOPMENT REVIEW SERVICES
[Signature]
Maintenance

Provide copies of test reports to:
City of Vancouver
Building Division
P.O. Box 1995
Vancouver, WA 98668-1995

CITY OF VANCOUVER
APPROVED
MAY 22 2003

FOR CONSTRUCTION
DEVELOPMENT SERVICES
REVIEWED BY: *[Signature]*

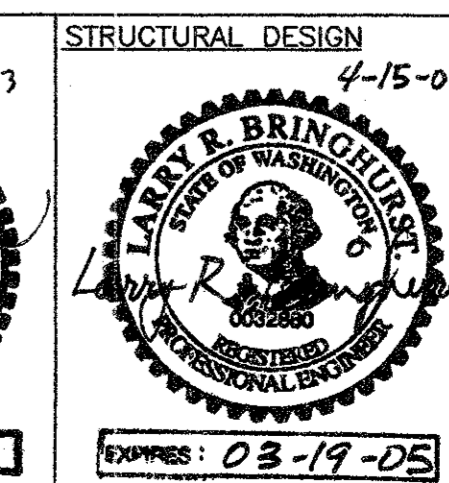
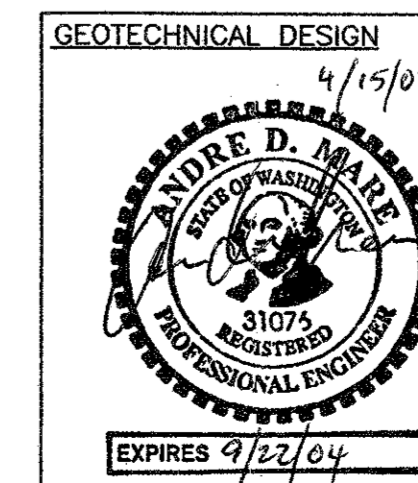

NOTE: IF "L" DOES NOT MEASURE 1" ADJUST SCALES ACCORDINGLY.
1" = 1'

04/15/2003 09:20 am I:\30102\012\POV\Main\501.dwg
 PACRIM GEOTECHNICAL INC.
 GEOTECHNICAL ENGINEERING AND APPLIED EARTH SCIENCES
 5895 Jean Road
 Lake Oswego, OR 97035
 Ph: 503-534-0265
 Fax: 503-534-0266
ReidMiddleton
 PORT OF VANCOUVER
 TERMINAL 2 SEAWALL STRENGTHENING
 VICINITY MAP, SITE PLAN,
 LEGAL DESCRIPTION AND SHEET INDEX
 SCALE: NTS
 DES: LRB SHEET NO.
 DR: GWK S1
 CH:
 F.B. OF SHEETS
 DATE: 1/03/2003
 FILE NO: 30212

DESIGN CRITERIA

- 1. CODE 1997 UBC /MODIFIED BY WASH. STATE BUILDING CODE
2. SEAWALL 'AT REST' PRESSURE SURCHARGE PRESSURE 45 PSF/FT OF HEIGHT 88 PSF (EQUIPMENT LOAD EQUIVALENT TO 2 FT OF SOIL)
3. WIND 90 MPH EXPOSURE C
4. SEISMIC ZONE 3 LATERAL PRESSURE 70 PSF

GENERAL REQUIREMENTS

- 1. ALL MATERIALS AND WORKMANSHIP SHALL CONFORM TO THE 1997 UNIFORM BUILDING CODE(UBC) AS MODIFIED BY THE 'WASHINGTON STATE BUILDING CODE'(WSBC).
2. THE LATEST EDITION OF ALL REFERENCED CODES, STANDARDS, AND SPECIFICATIONS SHALL GOVERN.
3. THE CONTRACTOR SHALL BE RESPONSIBLE FOR ALL CONSTRUCTION METHODS, TECHNIQUES, SEQUENCING, AND SAFETY REQUIRED FOR THE CONSTRUCTION.
4. SUBSTITUTIONS OF INDICATED PRODUCTS SHALL NOT BE MADE WITHOUT PRIOR WRITTEN APPROVAL FROM THE ENGINEER. 'SUBMIT MANUFACTURER'S PRODUCT DATA, AND ICBO EVALUATION REPORT.
5. STRUCTURAL MEMBERS SHALL NOT BE MODIFIED UNLESS SPECIFICALLY SHOWN, OR WITHOUT PRIOR WRITTEN APPROVAL WITH ASSOCIATED DETAIL SKETCHES FROM THE ENGINEER.
6. OWNER TO OBTAIN BUILDING PERMITS. ALL OTHER PERMITS REQUIRED FOR WORK SHALL BE CONTRACTOR'S RESPONSIBILITY.
7. DISTURBANCE OF EXISTING ASPHALT PAVEMENT SHALL BE REPAIRED IN KIND.
8. SEAWALL SHALL BE VISUALLY MONITORED BY THE CONTRACTOR DURING THE INSTALLATION OF THE TIEBACK ANCHORS. SHOULD CRACKS OR MOVEMENT BE OBSERVED, THE TIEBACK TENSIONING SHALL BE STOPPED AND THE GEOTECHNICAL ENGINEER IMMEDIATELY NOTIFIED.
9. THE GEOTECHNICAL ENGINEER MAY MODIFY THE LOCK OFF LOAD AND/OR MAXIMUM TEST LOAD BASED ON MEASURED DEFLECTIONS.
10. STATION LOCATIONS SHOWN ON THE DRAWINGS SHALL BE VERIFIED AND LOCATED PRIOR TO WALL DRILLING.
11. CONTRACTOR SHALL LOCATE ALL UTILITIES TO ENSURE NO CONFLICTS WITH GROUND ANCHORS.
12. EXISTING WALL REINFORCING SHALL BE LOCATED PRIOR TO WALL DRILLING AND SHALL NOT BE CUT OR DAMAGED.
13. TIEBACK ANCHOR HORIZONTAL PLACEMENT TOLERANCE SHALL BE (+/-)1/2" FROM FINAL LOCATIONS DETERMINED BY REBAR LOCATION.

PROJECT/SITE CONDITIONS

- 1. THE CONTRACTOR SHALL VERIFY ALL EXISTING CONDITIONS, IF EXISTING CONDITIONS DIFFER FROM THOSE SHOWN, THE GEOTECHNICAL ENGINEER SHALL BE NOTIFIED PRIOR TO CONTINUANCE OF THE WORK.
2. WORK IS WITHIN AN EXISTING OPERATING TERMINAL. CONTRACTOR SHALL MINIMIZE DISRUPTION TO MARINE OPERATIONS.
3. CONTRACTOR STAGING AREA LOCATION HAS BEEN NOTED ON SHEET S1, 'SITE PLAN'.
4. MATERIAL REMOVED FROM DRILLED HOLES SHALL BE COLLECTED AND STORED IN DROP BOXES AT STAGING AREA. OWNER WILL TEST AND DISPOSE OF REMOVED MATERIAL. PERSONAL PROTECTIVE ITEMS, SUCH AS GLOVES, FACE MASKS, ETC. MAY BE REQUIRED TO HANDLE REMOVED MATERIAL. CONTRACTOR IS RESPONSIBLE FOR PROVIDING PROTECTIVE ITEMS AND ENFORCING THE USE OF THEM BY CONTRACTOR PERSONNEL.
5. IF OBSTRUCTIONS ARE ENCOUNTERED DURING HOLE DRILLING THAT PREVENTS THE CONTINUANCE OF DRILLING, THE DRILLING SHALL BE STOPPED IN THAT HOLE AND THE OWNER AND GEOTECHNICAL ENGINEER IMMEDIATELY NOTIFIED. ALL EFFORTS SHALL BE MADE TO COMPLETE THE HOLE DRILLING PROCESS BY ANGLING THE HOLE TO PASS THE OBSTRUCTION OR CHANGING TO A ROCK BIT PRIOR TO ABANDONING THE HOLE LOCATION. DRILLING MAY CONTINUE ON ADJACENT HOLES.

TEMPORARY CONSTRUCTION FACILITIES

- 1. THE CONTRACTOR SHALL BE RESPONSIBLE FOR DESIGN, CONSTRUCTION, SEQUENCING, AND SAFETY OF ALL TEMPORARY SHORING, BRACING, ETC. REQUIRED FOR THE CONSTRUCTION.
2. CONTRACTOR'S WORKING PLATFORM SHALL NOT BE ATTACHED TO OR SUPPORTED BY THE SEAWALL OR IT'S FOOTING. CRANES OR BOOM TRUCKS THAT SUPPORT WORKING PLATFORMS SHALL BE LOCATED A MINIMUM DISTANCE BEHIND THE SEAWALL EQUAL TO THE HEIGHT OF THE SEAWALL PLUS 1 FOOT. PERMANENT SUPPORT IN THE COLUMBIA RIVER OR ON THE ROCK SLOPES IS NOT ALLOWED.
3. ALL INORGANIC LIQUIDS AND MATTER USED DURING THE INSTALLATION OF THE TIEBACK ANCHORS SHALL BE CONTAINED. THESE MATERIALS SHALL NOT COME IN CONTACT WITH THE SEAWALL, ROCK SLOPE, OR COLUMBIA RIVER.
4. CONTRACTOR SHALL PROVIDE EROSION CONTROL MEASURES AS REQUIRED TO PREVENT TRANSPORT OF SEDIMENT LADEN WATER DURING CONSTRUCTION ACTIVITIES.

SUBMITTALS

- 1. THE CONTRACTOR SHALL SUBMIT TO THE OWNER, BUILDING OFFICIAL, GEOTECHNICAL ENGINEER AND ENGINEER PRIOR TO FABRICATION/INSTALLATION THE FOLLOWING INFORMATION.
• SOIL ANCHOR SYSTEM (SEE WALL ANCHOR SECTION)
• GROUT PRODUCT DATA
• METAL FABRICATIONS SHOP DRAWINGS
• TEST/INSPECTION REPORTS
2. SUBMIT SHOP DRAWINGS PRIOR TO FABRICATION FOR REVIEW BY THE ENGINEER FOR GENERAL CONFORMANCE WITH THE DESIGN CONCEPT OF THE PROJECT AND GENERAL COMPLIANCE WITH THE INFORMATION GIVEN IN THESE CONTRACT DOCUMENTS.
3. THE OWNER SHALL REVIEW AND RETURN SUBMITTALS WITHIN 7 CALENDAR DAYS.

SPECIAL INSPECTIONS

- 1. SPECIAL INSPECTIONS SHALL CONFORM TO SECTION 1701 OF THE 'WASHINGTON STATE BUILDING CODE'.
• WALL REBAR/ DRILLED HOLE PLACEMENT CONTINUOUS
• SOIL ANCHOR GROUTING/INSTALLATION CONTINUOUS (SEE WALL ANCHOR SECTION)
• SOIL ANCHOR TENSIONING CONTINUOUS (SEE WALL ANCHOR SECTION)
• GROUT PLACEMENT TEST 3 CYLINDERS PERIODIC @ FW < 5/16"
• STRUCTURAL STEEL WELDING CONTINUOUS @ FW >5/16"

- 2. SPECIAL INSPECTIONS AND ASSOCIATED TESTING, WHETHER REQUIRED BY THE CONSTRUCTION DOCUMENTS OR BY THE GOVERNING BUILDING CODE, SHALL BE PERFORMED BY AN ACCREDITED INDEPENDENT TESTING AGENCY MEETING THE REQUIREMENTS OF ASTM E329 (MATERIALS), ASTM C1077 (CONCRETE), AND ASTM E543 (NONDESTRUCTIVE). THE TESTING AGENCY SHALL FURNISH TO THE GEOTECHNICAL ENGINEER AND ENGINEER A COPY OF THEIR SCOPE OF ACCREDITATION. SPECIAL INSPECTORS SHALL BE CERTIFIED BY THE BUILDING OFFICIAL. THE OWNER SHALL SECURE AND PAY FOR THE SERVICES OF THE TESTING AGENCY TO PERFORM ALL SPECIAL INSPECTIONS AND TESTS.
3. THE SPECIAL INSPECTOR SHALL OBSERVE THE INDICATED WORK FOR COMPLIANCE WITH THE APPROVED CONSTRUCTION DOCUMENTS. ALL DISCREPANCIES SHALL BE BROUGHT TO THE ATTENTION OF THE CONTRACTOR FOR CORRECTION, THEN, IF UNCORRECTED, TO THE ATTENTION OF THE ENGINEER AND THE BUILDING OFFICIAL.
4. THE SPECIAL INSPECTOR SHALL FURNISH INSPECTION REPORTS FOR EACH INSPECTION TO THE GEOTECHNICAL ENGINEER AND THE ENGINEER, THE CONTRACTOR, THE BUILDING OFFICIAL, AND THE OWNER WITHIN 5 DAYS OF THE INSPECTION. THE SPECIAL INSPECTOR SHALL SUBMIT A FINAL REPORT INDICATING THE WORK REQUIRING SPECIAL INSPECTION WAS INSPECTED AND IS IN CONFORMANCE WITH THE APPROVED CONSTRUCTION DOCUMENTS.

STRUCTURAL OBSERVATION

- 1. STRUCTURAL OBSERVATIONS SHALL CONFORM TO SECTION 1702 OF THE WASHINGTON STATE BUILDING CODE.
• SOIL ANCHOR INSTALLATION
• SOIL ANCHOR TENSIONING
2. STRUCTURAL OBSERVATIONS SHALL BE PERFORMED BY THE ENGINEER OF RECORD.

DEMOLITION AND DISMANTLING

- 1. THE CONTRACTOR SHALL COMPLY WITH ALL APPLICABLE STATE AND LOCAL REGULATIONS AND ORDINANCES CONCERNING DEMOLITION OPERATIONS AND ASSOCIATED REFUSE REMOVAL. WHERE THESE REGULATIONS DO NOT APPLY, APPLICABLE PARTS OF ANSI A10.6 'SAFETY REQUIREMENTS FOR DEMOLITION' SHALL BE FOLLOWED.
2. THE CONTRACTOR SHALL BE RESPONSIBLE FOR ALL DEMOLITION METHODS, TECHNIQUES, SEQUENCING, AND SAFETY REQUIRED FOR THE CONSTRUCTION.

EXISTING CONDITIONS

- 1. THE SEAWALL CONSTRUCTION, TIEBAR CONFIGURATION, AND ITEM LOCATIONS ARE BASED UPON LIMITED FIELD OBSERVATIONS CONDUCTED ON DECEMBER 5, 2002 AND JANUARY 2003. THE EXISTING CONSTRUCTION OBSERVATIONS WERE MADE FROM AN EXCAVATED HOLE BEHIND AND NEAR THE WEST END OF THE SEAWALL
2. CONSTRUCTION AND TIEBAR CONFIGURATIONS FOR THE REMAINDER OF THE WEST, MIDDLE AND EASTERN PORTIONS OF THE SEAWALL ARE ASSUMED BASED UPON THE WESTERN EXCAVATED OBSERVATIONS. NO CONSTRUCTION DOCUMENTS FOR THE EXISTING SEAWALL WERE AVAILABLE NOR WAS ANY EXCAVATIONS ALLOWED FOR THESE PORTIONS OF THE WALL.
3. FOR HISTORICAL COLUMBIA RIVER LEVELS VISIT THE NOAA WEBSITE. LOW WATER ELEV. = 0.0 FT., ORDINARY HIGH WATER ELEV. = 16.0 FT., 100 YEAR FLOOD ELEV. = 27.0 FT., COLUMBIA RIVER DATUM.

WALL ANCHORING

- 1. PHASING
• PHASE I BID: FROM STA. 1+00.0 TO STA. 4+31.0 AND STA. 8+27.0 TO STA. 9+05.6 TO BE COMPLETED 2003.
• PHASE II BID: FROM STA. 0+41.0 TO 0+81.5 AND STA. 4+31.0 TO STA. 8+27.0 TO BE COMPLETED 2004.
2. DESIGN CRITERIA

- A. THE CONTRACTOR SHALL BE RESPONSIBLE FOR INSTALLING GROUND ANCHORS IN THE LOCATIONS SHOWN HAVING ULTIMATE LOAD-CARRYING CAPACITY OF AT LEAST TWICE THE GROUND ANCHOR DESIGN LOADS SHOWN ON THE DRAWINGS.
B. MINIMUM ANCHOR BOND LENGTHS AND FREE LENGTHS ARE SHOWN ON THE PROFILES.
C. THE ANCHOR TYPE AND METHOD OF INSTALLATION SHALL PROVIDE MINIMAL DISTURBANCE TO THE SOIL.
D. THE CONTRACTOR SHALL PROVIDE ANCHOR CORROSION PROTECTION EQUIVALENT TO OR BETTER THAN CLASS II PROTECTION AS SPECIFIED IN 'DESIGN MANUAL FOR PERMANENT GROUND ANCHOR WALLS', FHWA, 1998.
E. ANCHOR INCLINATION FROM HORIZONTAL SHALL BE A MINIMUM OF 10 DEGREES AND A MAXIMUM OF 20 DEGREES.
F. FOR USE IN DESIGN, THE FOLLOWING SOIL PARAMETERS SHALL BE ASSUMED:
• SOIL DESCRIPTION = SAND TO SILTY SAND WITH GRAVEL, LOOSE TO MEDIUM DENSE
• ANGLE OF INTERNAL FRICTION = 33 DEGREES
• COHESION, C = 0 PSF
• WET UNIT WEIGHT = 110 PCF
G. ADDITIONAL SOIL AND GROUNDWATER INFORMATION, INCLUDING SOIL BORING LOGS, IS INCLUDED IN THE FOLLOWING REPORT AVAILABLE FROM THE OWNER:
'CONDITION REPORT, STRUCTURAL ANALYSIS OF RETAINING WALL, PORT OF VANCOUVER, VANCOUVER, WASHINGTON', BY PACRIM GEOTECHNICAL, DATED JANUARY 9, 2003.

SUBMITTALS

- A. THE CONTRACTOR SHALL PREPARE AND SUBMIT DETAILED DESIGN CALCULATIONS AND DRAWINGS SIGNED AND STAMPED BY A PROFESSIONAL ENGINEER LICENSED IN THE STATE OF WASHINGTON. THE SUBMITTAL SHOULD INCLUDE THE FOLLOWING:
• GROUND ANCHOR DESIGN CALCULATIONS WITH SCHEDULE GIVING THE TENDON SIZE AND GRADE OF STEEL, ANCHOR INCLINATION, TOTAL LENGTH, UNBONDED LENGTH, AND TENDON BOND LENGTH.
• IF HELICAL ANCHORS ARE USED, SIZE AND SPACING OF HELICES SHALL BE PROVIDED.
• SECTION VIEWS TO SHOW ANCHOR LOCATIONS RELATIVE TO EXISTING CONCRETE DEADMAN, EXISTING UTILITIES, OR OTHER STRUCTURES AS APPROPRIATE.
• NOTES OUTLINING THE GROUND ANCHOR TESTING PROCEDURES AND EQUIPMENT, FOLLOWING THE REQUIREMENTS PRESENTED HEREIN. INCLUDE PROCEDURES TO ESTABLISH FIXED REFERENCE POINT FOR DEFLECTION MEASUREMENTS.
• DETAILS OF ANCHOR CORROSION PROTECTION.
• DETAILS OF ANCHOR BEARING PLATE.

- B. THE CALCULATIONS AND DRAWINGS SHALL BE SUBMITTED TO THE OWNER A MINIMUM OF 15 DAYS PRIOR TO COMMENCEMENT OF PERMANENT GROUND ANCHOR WORK.
C. APPROVAL OF THE DESIGN SUBMITTAL DOES NOT RELIEVE THE CONTRACTOR OF RESPONSIBILITY FOR THE SUCCESSFUL COMPLETION OF THE WORK.
D. DELAYS DUE TO UNTIMELY SUBMISSIONS AND/OR INADEQUATE INFORMATION OR DETAILS SHALL NOT BE GROUNDS FOR A TIME EXTENSION.
E. NO ADDITIONAL COMPENSATION WILL BE MADE FOR ADDITIONAL LABOR, MATERIAL, OR EQUIPMENT NECESSARY TO COMPLY WITH THE PROJECT SPECIFICATIONS AS A RESULT OF THE OWNER'S REVIEW.
F. THE OWNER SHALL REVIEW AND RETURN SUBMITTALS WITHIN 7 CALENDAR DAYS.

ANCHOR TESTING

- A. THE ANCHOR TESTING SPECIFIED HEREIN SHALL BE PERFORMED BY THE CONTRACTOR IN THE PRESENCE OF THE GEOTECHNICAL ENGINEER.
B. PROOF TESTING SHALL BE PERFORMED IN ACCORDANCE WITH THE RECOMMENDATIONS OF THE POST-TENSIONING INSTITUTE PUBLICATION, 'RECOMMENDATIONS FOR PRESTRESSED ROCK AND SOIL ANCHORS', 1986, AND AS SPECIFIED HEREIN.
C. ALL ANCHORS SHOULD BE PROOF-LOADED IN INCREMENTS TO 130 PERCENT OF THEIR DESIGN LOAD (1.30 DL). EACH LOAD INCREMENT SHOULD BE HELD UNTIL THE DEFORMATION STABILIZES (NORMALLY ABOUT ONE MINUTE) AND THE LOAD AND CORRESPONDING DEFORMATION SHOULD BE RECORDED. AFTER REACHING 1.30 DL, THE LOAD SHOULD BE HELD FOR 10 MINUTES AND THEN REDUCED TO THE LOCK-OFF VALUE.
D. ALL ANCHORS SHALL BE LOCKED OFF AT 80 PERCENT OF THE DESIGN LOAD OR AT A LOWER VALUE AS DIRECTED BY THE GEOTECHNICAL ENGINEER.
E. WALL DEFLECTIONS SHALL BE MONITORED BY THE CONTRACTOR DURING THE INSTALLATION OF TIEBACKS. THE GEOTECHNICAL ENGINEER MAY MODIFY THE LOCK OFF LOAD AND/OR MAXIMUM TEST LOAD BASED ON MEASURED DEFLECTIONS.

ACCEPTANCE CRITERIA

- A. THE CONTRACTOR SHALL EVALUATE THE ANCHOR TEST RESULTS AND DETERMINE WHETHER THE ANCHOR IS SATISFACTORY. THE RESULTS AND EVALUATION SHALL BE SUBMITTED TO THE GEOTECHNICAL ENGINEER FOR REVIEW.
B. AN ANCHOR SHALL BE ACCEPTABLE IF IT MEETS THE FOLLOWING CRITERIA:
• RANDOM LIFT-OFF TESTS MAY BE SPECIFIED BY THE OWNER'S ENGINEER. THE LOAD DETERMINED FROM THE LIFT-OFF READING SHALL BE WITHIN 5% OF THE SPECIFIED LOCK-OFF LOAD. IF THE LOAD IS NOT WITHIN 5% OF THE LOCK-OFF LOAD, THE ANCHORAGE SHALL BE RESET AND ANOTHER LIFT-OFF READING SHALL BE MADE.
• THE CREEP RATE SHALL NOT EXCEED 0.08 INCHES PER LOG CYCLE OF TIME DURING THE FINAL LOAD INCREMENT OF THE PROOF TEST REGARDLESS OF TENDON LENGTH AND LOAD.
C. THE GEOTECHNICAL ENGINEER SHALL DETERMINE WHETHER AN ANCHOR WHICH FAILS TO MEET THE ABOVE MINIMUM ACCEPTANCE CRITERIA MAY BE INCORPORATED IN THE WORK.

GROUTED ANCHORS

- A. ALL THREADED BAR: GRADE 150, ASTM A722 TYPE II OR ASTM A311.
B. SPHERICAL ANCHOR NUTS: ASTM A536, GRADE 100-70-03 OR ASTM 108, GRADE C-11L44.
C. HEAVY DUTY HEX NUT: ASTM A311, CLASS B.
D. BEARING ANCHORAGE PLATE: ASTM A36, A572 OR A588.
E. COUPLERS: ASTM A311, CLASS B, GRADE 1144.
F. CEMENT GROUT: ASTM C845, TYPE E-1.
G. POLYETHYLENE CORRUGATED TUBE: ASTM D3350, INDEX NO. 335520 C, TABLE 1, OR ASTM D1248.
H. SMOOTH PLASTIC SLEEVING: PVC PER ASTM D1785 OR POLYETHYLENE PER ASTM D1248.
I. GREASE: ASTM B117 AND ASTM D1743.
J. CENTRALIZERS: PVC PER ASTM D2241, CLASS 200 OR ASTM D1785, SCHEDULE 40.
K. EXTERNAL END CAPS: PVC 1120 PER ASTM D1785, SCHEDULE 40.

SOIL SCREW ANCHORS

- A. SHAFT: ASTM A29.
B. HELIX: ASTM A715 OR ASTM A656.
C. COUPLING NUTS: ASTM A320, GRADE L7.
D. WELDING: PER AWS D1.1.
E. WELDER CERTIFICATION: PER AWS D1.1, SECTION 4.
F. HOT DIP GALVANIZING: PER ASTM A153.

METAL FABRICATIONS

- 1. STEEL SHAPES, PLATES, AND BARS: ASTM A36.
2. STEEL SHAPED TUBING: ASTM A500 GRADE B.
3. STEEL PIPE: ASTM A53 GRADE B.
4. WELDING FILLER METAL: AWS A5.1 OR A5.5 E70XX, AWS A5.20 E7XT, OR AWS A5.29 E7XTX, LOW-HYDROGEN TYPE. WELDING SHALL BE IN ACCORDANCE WITH AWS D1.1 'STRUCTURAL WELDING CODE-STEEL.' WELDERS SHALL BE QUALIFIED IN ACCORDANCE WITH CHAPTER 4 OF AWS D1.1.
5. STANDARD, JAMB, AND HEAVY HEX NUTS: ASTM A563.
6. PLAIN HARDENED WASHERS: ASTM F436.
7. PLATE WASHERS (PW): STRUCTURAL GRADE MLD STEEL.
8. ANCHOR BOLTS (AB): ASTM A307 GRADE B HEAVY HEX TYPE. INSTALL BY TEMPLATING PRIOR TO CONCRETE PLACEMENT.
9. GRATING: TYPE W-19-4, HOT DIP GALVANIZED PER ASTM A123.

PAINTS AND COATINGS

- 1. PAINT SHALL BE APPLIED IN ACCORDANCE WITH SSPC PA1 'SHOP, FIELD, AND MAINTENANCE PAINTING' AND THE MANUFACTURER'S LABELED INSTRUCTIONS AND SPECIFICATIONS.
2. SURFACE PREPARATION OF STRUCTURAL STEEL SHALL BE IN ACCORDANCE WITH SSPC SP1 'SOLVENT CLEANING' AND SSPC SP6 'COMMERCIAL BLAST CLEANING.'
3. SHOP PRIME COAT: STRUCTURAL FABRICATIONS SHALL BE SHOP PRIMED PER SSPC-PAINT 30, 'WELD-THROUGH INORGANIC ZINC COATING'. ALL SHARP EDGES, AREAS DIFFICULT TO COAT AND WELDS SHALL BE STRIPE COATED PRIOR TO APPLICATION OF FULL COAT.
4. BASE COAT: 'DEVTRAN 2610C' SEMI-GLOSS, LOW TEMPERATURE CURE EPOXY COATING AS MANUFACTURED BY ICI DEVOE COATINGS. THE COATING SHALL BE APPLIED IN ONE COAT OF 6 MILS DFT. STRIPE COAT ALL SHARP EDGES, AREAS DIFFICULT TO COAT AND WELDS PRIOR TO APPLICATION OF FULL COAT.
A. COLOR: GRAY (SHADE TO MATCH EXISTING SEAWALL) AT WALES.
B. COLOR: SAFETY YELLOW AT LADDER ASSEMBLY.
5. TOP COAT: 'DEVTHANE 378', ALIPHATIC URETHANE SEMI-GLOSS COATING AS MANUFACTURED BY ICI DEVOE COATINGS. THE COATING SHALL BE APPLIED IN ONE COAT OF 3 MILS DFT. STRIPE COAT ALL SHARP EDGES, AREAS TO COAT AND WELDS PRIOR TO APPLICATION OF FULL COAT.
A. COLOR: GRAY (SHADE TO MATCH EXISTING SEAWALL) AT WALES.
B. COLOR: SAFETY YELLOW AT LADDER ASSEMBLY.
6. TOUCH-UP OF PAINTED STEEL SURFACES SHALL BE WITH THE SAME KIND AND NUMBER OF COATS AS THE ORIGINAL COATING. TOUCH-UP OF PAINTED STEEL SURFACES SHALL BE IN ACCORDANCE WITH SECTION 9 OF SSPC PA1 'SHOP, FIELD, AND MAINTENANCE PAINTING.' SURFACE PREPARATION SHALL BE IN ACCORDANCE WITH SSPC SP3 'POWER TOOL CLEANING.'

ABBREVIATIONS

Table with 4 columns: Symbol, Description, Abbreviation, Information. Includes entries for ANCHOR ASSEMBLY, AMERICAN WELDING SOCIETY, AMERICAN SOCIETY FOR TESTING AND MATERIALS, BOLT, BEAM, BEARING, CENTERLINE, CLEAR CONCRETE, CONTINUOUS, CENTER, CENTERED, DOUBLE DEEP, DEMOLISH, DETAIL, DIAMETER, DIMENSION, DESIGN, EACH, ELEVATION, EMBEDMENT, EQUAL, EXISTING, FLANGE, FLAT, FACE OF CONCRETE, FACE OF WALL, FRAMING, FAR SIDE, FASTENER, FOOT, FOOTING, GAGE, HORIZONTAL, HEIGHT, INFO, LD, LB, MATL, MAX, MET, MID, MIN, MODIFIED, NS, NTS, ON CENTER, OUT-TO-OUT, OPPOSITE, PL, PLCS, PNL, PROJ, R, REINF, SIM, SPC, SPCG, SQ, STL, T&B, THRD, T/*, TYP, UN, W/, WSH.

Professional Engineer stamps for GEOTECHNICAL DESIGN (4/15/03) and STRUCTURAL DESIGN (04-15-03). Includes City of Vancouver Approved stamp dated MAY 22 2003.

NOTE: IF 'L' DOES NOT MEASURE 1" ADJUST SCALES ACCORDINGLY.

Vertical sidebar containing: PACRIM GEOTECHNICAL INC., 5905 Jean Road, Lake Cowichan, BC V9P 2G5, Tel: 503-534-0765, Fax: 503-534-0766; Reid Middleton logo; PORT OF VANCOUVER TERMINAL 2 SEAWALL STRENGTHENING STRUCTURAL NOTES; CONSTRUCTION DRAWINGS REVISION table; SCALE 1=1; SHEET NO. LRB; DR. GWK; CH. S2; DATE 1/03/2003; FILE NO. 30212.

04/15/2003 08:50 am I:\30\02\012.POV\lrb\5202.dwg

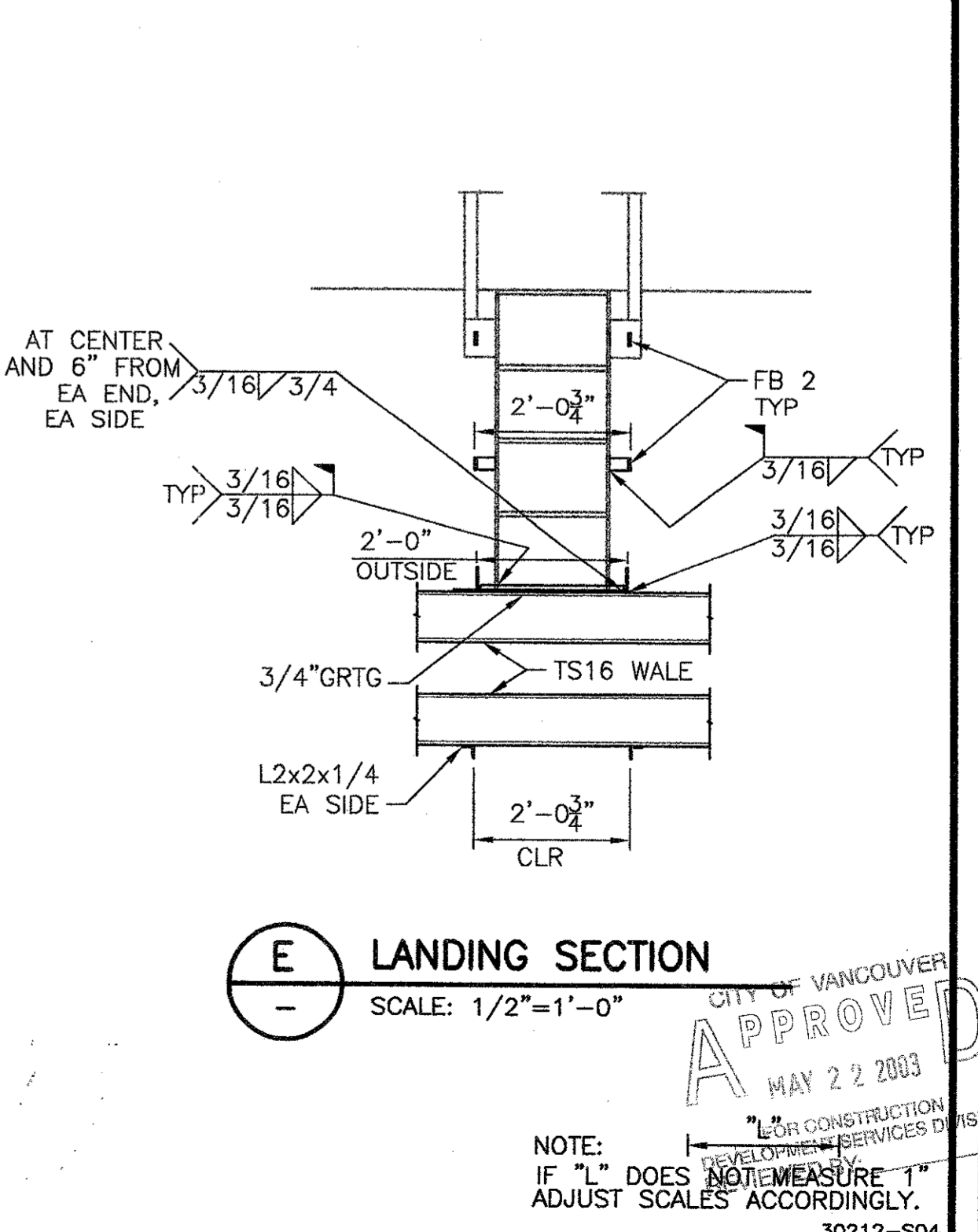
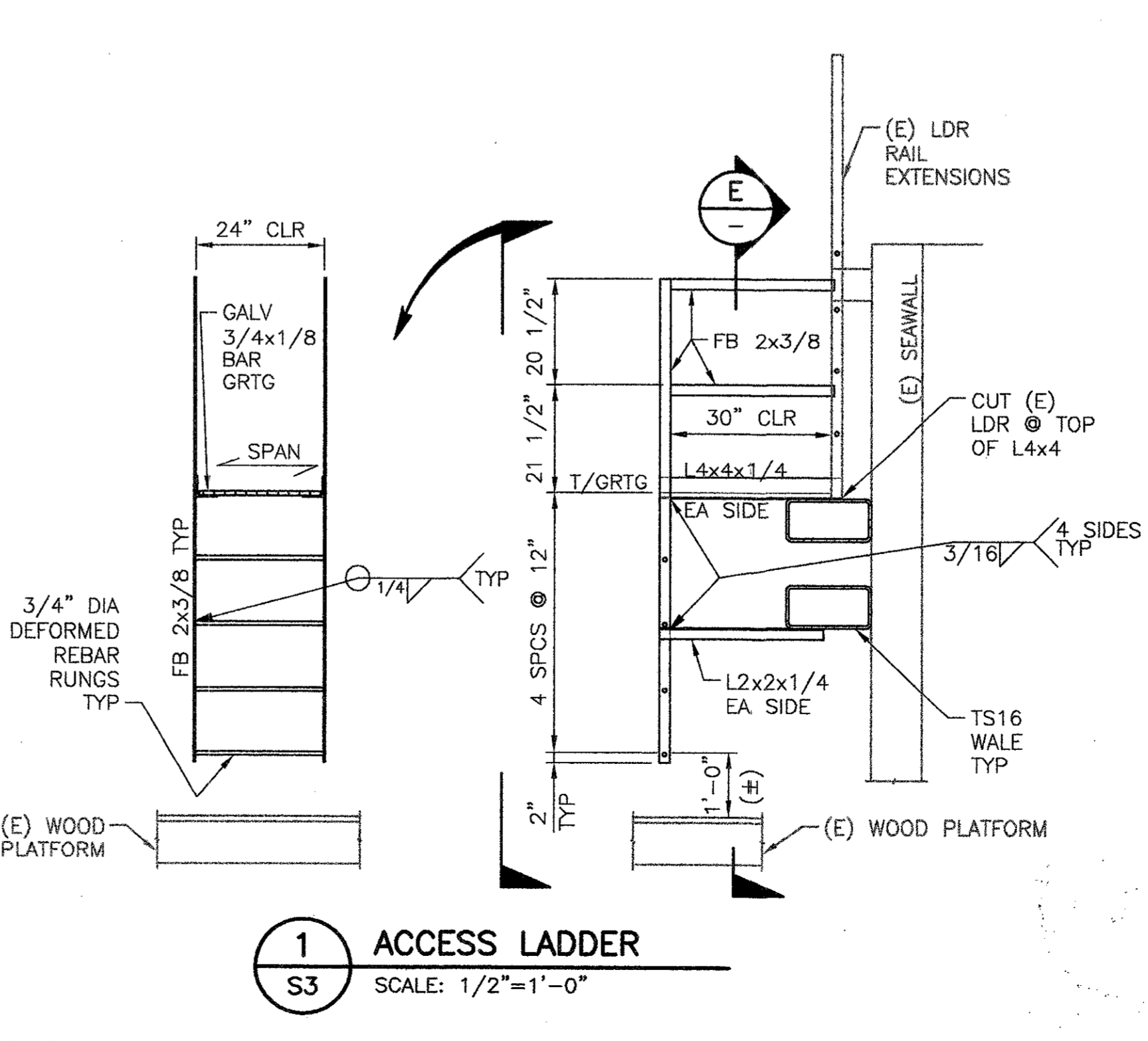
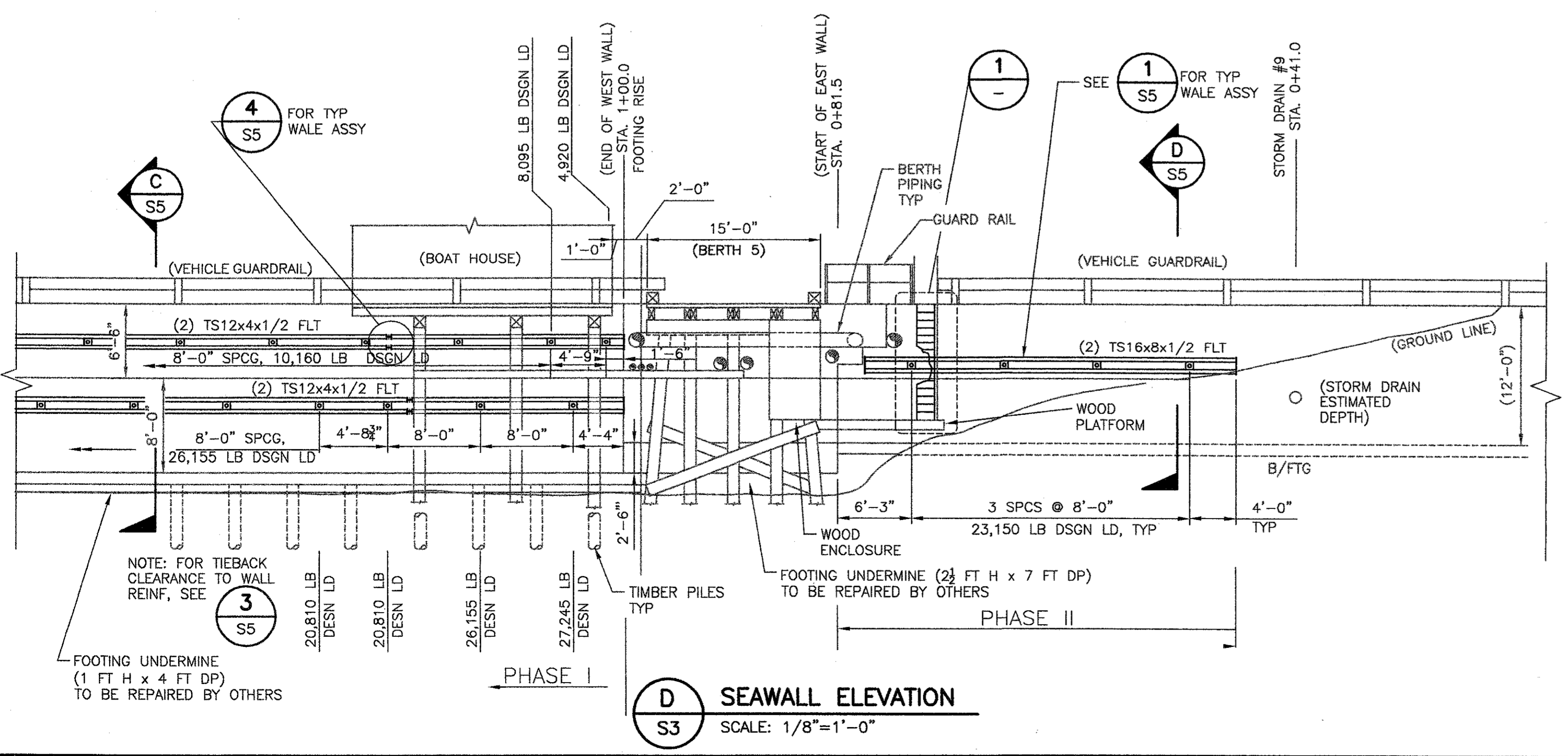
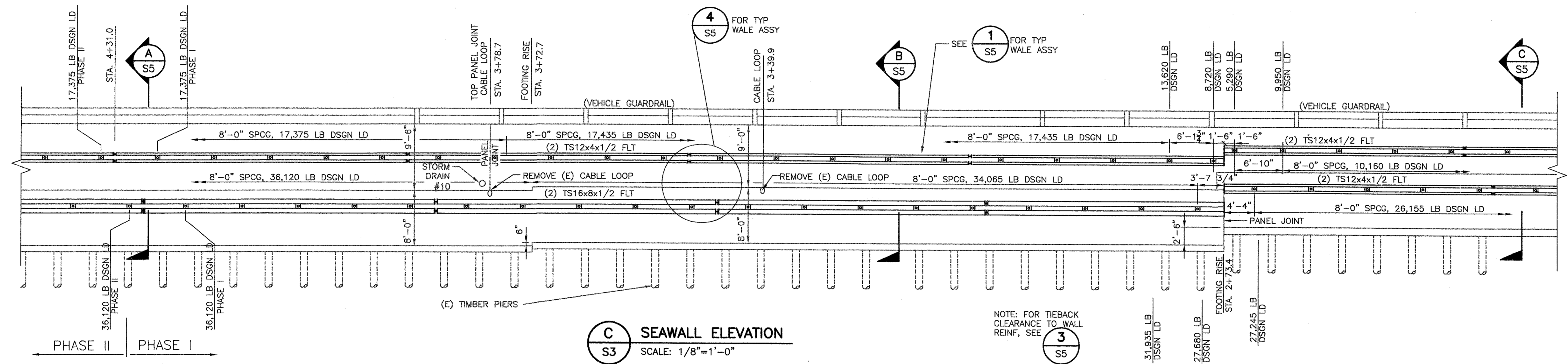
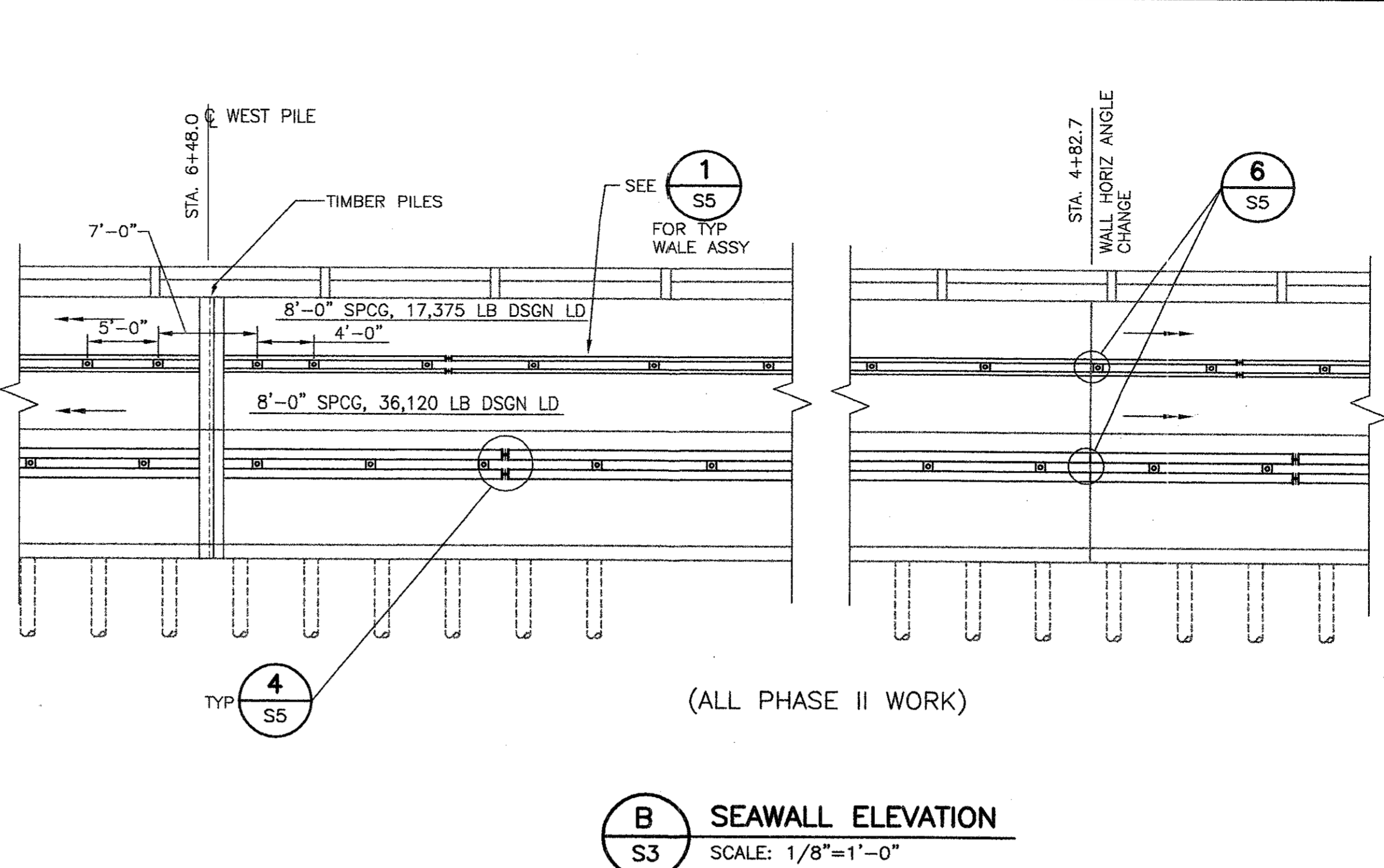
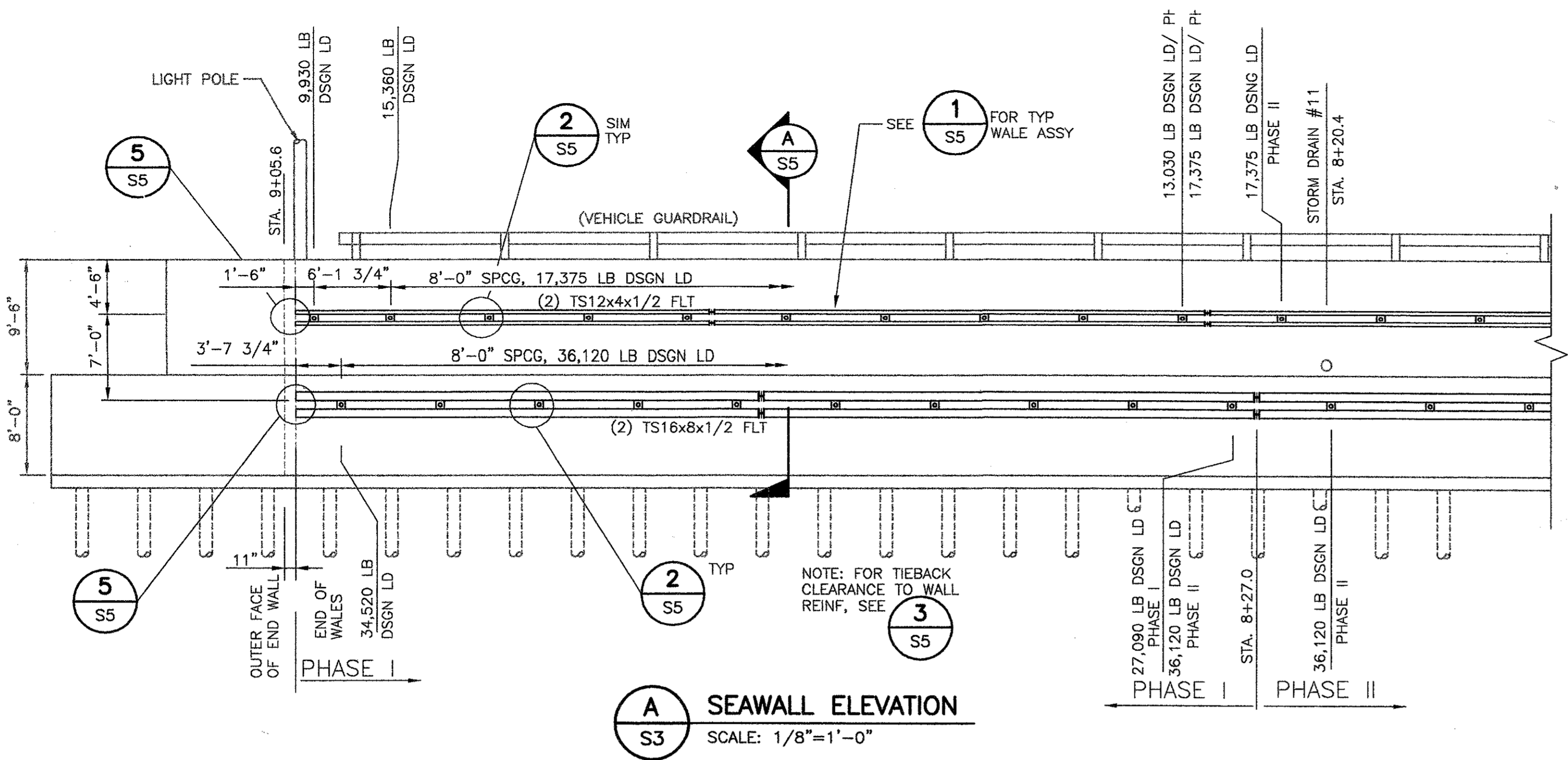

GEOTECHNICAL DESIGN
ANDRE D. MILES
 31075
 PROFESSIONAL ENGINEER
 EXPIRES 9/22/07

STRUCTURAL DESIGN
 04-15-03
LARRY R. BRINGHOUT
 31075
 PROFESSIONAL ENGINEER
 EXPIRES 03-19-05

0 4/16/03 LRB CONSTRUCTION DRAWINGS
 NO. 1 DATE BY REVISION

PACRIM GEOTECHNICAL INC.
 GEOTECHNICAL ENGINEERING AND APPLIED EARTH SCIENCES

5885 Jean Road
 Vancouver, BC V6P 4C6
 Tel: 604.534.0066
 Fax: 604.534.0066

Reid Middleton

PORT OF VANCOUVER
TERMINAL 2 SEAWALL STRENGTHENING
PARTIAL ELEVATIONS

SCALE 1/8"=1'-0"
 SHEET NO. **S4**
 DATE 1/03/2003
 FILE NO. 30212

04/15/2003 09:17 am I:\30102\012.P0W\Wall_S04.dwg

APPROVED
 MAY 22 2003
 LRB CONSTRUCTION SERVICES INC.
 NOTE: IF "L" DOES NOT MEASURE 1" ADJUST SCALES ACCORDINGLY.
 30212-S04

Appendix D

Sampling and Analysis Plan

Appendix D – Sampling and Analysis Plan

Table of Contents

1.0 SAMPLE LOCATION CONTROL.....	1
2.0 SEDIMENT SAMPLING.....	1
2.1 Equipment List.....	1
2.2 Sediment Collection Using Coring Device	2
2.3 Sediment Sample Collection Procedures	4
3.0 SURFACE WATER SAMPLING	5
4.0 DOCUMENTATION	6
4.1 Documentation Entries	6
4.2 Specific Requirements.....	7
5.0 SAMPLE CONTAINERS AND HANDLING.....	9
5.1 Container Requirements.....	9
5.2 Labeling Requirements.....	10
5.3 Packaging and Shipping Requirements.....	10
6.0 DECONTAMINATION PROCEDURES.....	10
6.1 Personnel Decontamination.....	10
6.2 Sampling Equipment.....	10
7.0 INVESTIGATION DERIVED WASTE HANDLING	11
8.0 QUALITY ASSURANCE PLAN.....	11
8.1 Quality Assurance Objectives for Data Management	11
8.2 Sampling Protocols.....	14
8.3 Sample and Document Custody Procedures.....	14
8.4 Equipment Calibration Procedures and Frequency	16
8.5 Analytical Procedures	16
8.6 Data Reduction, Validation, and Reporting.....	16
8.7 Performance Audits	17
8.8 Data Measurement Assessment Procedures	17
8.9 Corrective Actions.....	18
8.10 Quality Assurance Reports	18

Tables

D-1	Sediments - Analytical Methods – Sample Handling and Container Requirements
D-2	Surface Water - Analytical Methods — Sample Handling and Container Requirements
D-3	Analytical Methods – Sediment Reporting Limit Goals
D-4	Sediments - Laboratory Quality Control Sample Analysis Summary
D-5	Surface Water - Laboratory Quality Control Sample Analysis Summary

Appendix D – Sampling and Analysis Plan

Figure

D-1 Subsurface Core Log Form

Attachment

A Surface Water Sampling – Supporting Information

Appendix D – Sampling and Analysis Plan

1.0 Sample Location Control

The horizontal and vertical positions of the sediment and surface water sampling locations will be determined by referencing each sampling location to state plane coordinates through the use of survey control points, onshore landmarks, and differential global positioning systems (DGPS). The following information will be documented at each sampling station:

- Time and date;
- Horizontal location in local grid coordinates, referenced to the North American Datum of 1983 (NAD83); and
- River level and mudline elevations referenced to the NAVD88 datum.

Positioning while sampling will be performed using a DGPS. Horizontal locations of samples will be located to an accuracy of +/- 3 feet or less. Vertical locations of sediment samples will be located to an accuracy of +/- 2 feet. Care will be taken to achieve horizontal and vertical accuracy to the maximum extent possible, so that samples can be taken from the same location during future sampling events. It should be noted, however, that subsurface heterogeneity may be significant event within a close accuracy range of one to two feet.

Columbia River stage levels will be evaluated prior to the investigation. River mudline elevations, and thus the vertical control on sediment sample locations, will be determined by subtracting depth to mudline (from the sampling vessel) from the river surface elevation. The depth of surface water samples will be determined by subtracting the depth to the sample intake point from the river surface elevation. River surface elevation will be estimated using tide/river stage prediction data provided by the National Oceanic and Atmospheric Administration (NOAA) for Vancouver Tide station #9440083 located approximately 0.5 mile to the east of the project area. During periods of extreme precipitation, dam openings, snow melt, etc., actual river levels may significantly exceed river stage levels predicted on the tidal charts. Predicted river stage levels must approximate actual verified levels to ensure vertical accuracy during investigation activities. Therefore, the close monitoring of the factors that affect river stage will be essential in timing the investigation.

2.0 Sediment Sampling

Sediment samples will be collected using vibracore sampler.

2.1 Equipment List

The following general equipment will be required during collection procedures:

Appendix D – Sampling and Analysis Plan

- Personal protective equipment as required by the project health and safety plan (HASP);
- Navigation and site maps;
- Sampling vessel;
- Vibracore;
- Aluminum core barrel with polycarbonate liner and end caps;
- Decontamination materials;
- Weighted tape measure calibrated in 0.1-foot increments;
- Duct tape;
- Camera;
- Field notebook;
- Sample jars and labels;
- Sample analysis plan; and
- Chain-of-custody forms.

2.2 Sediment Collection Using Coring Device

At the majority of the sample locations, sediment cores will be collected to obtain surface and subsurface sediment samples. The coring device is comprised of an outer aluminum jacket with a polycarbonate liner. The vibracore system utilizes a high frequency vibrating head to break down the frictional resistance of the sediment, which allows the core tube to penetrate into the sediment with minimal disruption. Sediment coring will be conducted using the following procedures:

- Maneuver the sampling vessel to the target sample location. Secure the vessel in place using spuds, anchors, or tie lines in a two- or three-point anchoring system.
- Drop a weighted object (i.e. measuring tape) to the anticipated mudline to evaluate whether the river sediments are accessible or covered with rock. If rocky, the field personnel should be able to feel the weighted object impact the rock. A determination that rocks are present at the river bottom, and that core penetration is a low probability, is considered a failed attempt. After a failed attempt, the vessel will be relocated a minimum of 5 feet away and another attempt will be made to assess the subsurface. In general, offsets will be made parallel to the shoreline, but may be offset perpendicular to the shoreline if the area is particularly rocky. A maximum of four attempts will be made at a given sample collection area. Failed attempts will be documented in the field notes.
- Once the targeted area is deemed suitable for core collection, select an appropriate 3- or 4-inch (outside diameter) core tube type and length based on the bathymetry data and target elevation. Mount a clean coring tube into the vibracore device. A core catcher will be inserted into the base

Appendix D – Sampling and Analysis Plan

- of the coring tube – which will allow sediment into the core, but prevent it from falling out when the core is lifted.
- Lower the coring apparatus with the core tube attached vertically through the water column, tube end first, until the mudline is reached.
 - Vibrate the core into the sediment to the targeted depth or point of refusal, whichever is shallower. Measure and record the depth of core tube penetration into the sediments in the field notebook.
 - Pull the apparatus upward (using a winch) to the surface while maintaining the core in a vertical position. Cap the bottom of the core tube with the core catcher remaining in place.
 - Allow water overlying the core tube in the coring apparatus to drain prior to removing the core tube.
 - Estimate the recovered length of the sediment core and record it in the field notebook.
 - The length of the cores recovered in the tubing will be determined indirectly by tapping the outer aluminum core with a metal rod from top to bottom. The spot where the pitch of the sound changes corresponds to the approximate top of the recovered core.
 - The distance between the top of the sediment in the core tube and the bottom of the coring tube corresponds to the estimated length of the recovered core.
 - Compare the length of the recovered core with the core penetration depth.
 - If the recovered length of the sediment core is more than 60 percent of the penetration depth, keep the core.
 - If an insufficient amount of material is recovered, discard the core over the side of the sampling vessel. Rinse the core tube with river water and prepare to make an additional attempt. Care will be taken to discard the material away from the sampling area to avoid cross contamination.
 - An additional attempt will be made at a minimum distance of 5 feet from the previously attempted location.
 - A maximum of three attempts to advance a core will be made for a given location.
 - Rinse the core tubes with river water between consecutive attempts.
 - If all three attempts to collect a core are unsuccessful based on recovery alone (i.e., less than 60 percent recovery), retain the final core for analysis and indicate that the targeted recovery was not achieved.
 - Remove the core tube from the vibracore device and place a second cap on top of the core tube. Secure the cap in place with duct tape. Rinse the outside of the core tube with a small amount of river water.

Appendix D – Sampling and Analysis Plan

- Label each core with the station identification, core length, and an arrow indicating the top of the core. Label the core by scratching into the surface of the core barrel and with an indelible marker.
- Store the core vertically while on the vessel and transport to the processing area.

2.3 Sediment Sample Collection Procedures

The following subsections describe the methods for collecting the sediment samples from the sample coring device.

2.3.1 Sample Collection Method

Once sediment coring is complete, the cores will be transported in an upright position, on ice, to a location onshore for processing. Processing will occur using an electric saw to cut along the length of the core in two places, forming two D-shaped core halves. Only the barrel, not the sediments, will be cut by the saw. When sediment is collected from the core, care will be taken not to collect sediment in contact with the core barrel. The samples will not be composited because of the potential for loss of volatiles during the mixing process that could result in low-biased analytical results.

Core sections will not be opened until the sampler is ready to collect samples. The core will be opened and the samples will be immediately collected from the approximate center of the core sample intervals. This method will reduce the losses of volatile organic compounds (VOCs) during sample transport, handling, and analysis relative to standard sediment sampling techniques. Samples will be collected into glass jars that have PTFE-lined septum caps. A minimum of 50 grams of sample will be collected for VOC analysis. Care will be taken to fill the jar completely to limit headspace in the container. The vial caps will not be removed throughout the entire storage, preparation, and analysis procedure.

Additionally, two large (6-ounce or greater) soil jars will be collected at each sample location for dry weight analysis and total organic carbon (TOC) analysis. If sufficient sample volume is available a sample may be collected for future grain size analysis. A smaller sample may be collected if there is insufficient volume of material that is similar in color, grain size, etc. to the analytical sample.

2.3.2 Sample Selection

For evaluating the vertical extent of contamination, the following subsampling scheme will be used for the cores. The top 6 inches of the core will be collected as the surface sample. Additional subsurface samples will be collected at 2-foot intervals below the surface sample. Therefore, the first subsample will be the approximately 1.5- to 3.5-foot section below mudline, and the subsamples will continue in 2-foot segments down to 7 feet below the mudline (3.5 to 5.5 feet and 5.5 to 7 feet). The lithology of each sample interval will be logged in the field notes and the soil will be screened for VOCs using a photoionization detector

Appendix D – Sampling and Analysis Plan

(PID). PID screening is a standard sampling procedure and is not intended to replace laboratory analytical results.

To the extent possible, samples will be submitted to the laboratory within 24 hours of sample collection. In order to report analytical results as dry weight, an additional jar of sediment will be collected at each sample location for a percent solids analysis.

3.0 Surface Water Sampling

Sample Collection Method. At the request of Ecology, surface water samples will be collected into a passive diffusion bag (PDB) placed at the surface water-sediment interface. Manufacturer information on PDB's can be found at the Columbia Analytical Services website (<http://www.caslab.com/Passive-Diffusion-Bags-PDB-Samplers/>).

- The selected PDB will be a minimum of 24 inches long and 1.5 inches in diameter. This will hold 220 mL of surface water, adequate to fill five (5) 40 mL VOA containers. The PDB will be prefilled with ASTM Type II certified, laboratory-grade, analyte-free, deionized water.
- The PDB will be attached to an approximately 2 by 2 foot aluminum expanded sheet using zip ties. These sheets have the appearance of a diamond shaped mesh, and will allow water to pass through the sheet as it is lowered down into the river. The sheet may be weighted at the corners if needed. The use of an expanded sheet will allow the passive membrane to lie at the sediment interface while not sinking into the sediment, and also allows for easy deployment and retrieval without the use of a diver.
- A line will be attached to the expanded aluminum sheet and attached to a buoy, to allow for retrieval. Given that the river bottom will not likely be visible from the sampling vessel, a camera will be dropped down alongside the line to ensure the sampler is placed on a flat surface.
- Depending on access, which may be limited by shipping vessel traffic at the docking berth, the PDB will be retrieved between 48 to 96 hours after deployment. The duration of PDB deployment will be recorded in the field notes.
- After retrieving the PDB, it will be removed from the expanded aluminum sheet for sample processing.

Sample Handling and Analysis. A simple cut will be made at top of the PDB, and the surface water will be poured directly into laboratory approved sampling containers (SAP; Table D-2) and stored on ice. Because the samples will be analyzed for volatile constituents, care will be taken to not have any headspace in the sample. The surface water samples will be submitted to a Washington accredited laboratory for HVOCs by EPA Method 8260B. Unless otherwise specified, the samples will be submitted to the laboratory within the 14-day recommended hold time for analysis. Additional information on surface water sampling procedures is provided in the SAP (Appendix D).

Appendix D – Sampling and Analysis Plan

4.0 Documentation

Field activities and samples must be properly documented during the sampling process. Documentation of field activities provides an accurate and comprehensive record of the work performed sufficient for a technical peer to reconstruct the day's activities and provide certification that all necessary requirements were met. General requirements include:

- Use of bound field books as the primary source for information collection and recording. Field books should be dedicated to the project and appropriately labeled.
- Use of a Field Activity Log to formally document activities and events as a supplement to bound field books. The Field Activity Log can be a standard or project-specific form or a bound field book. Preprinted standard forms are available for many activities and should be used whenever possible. These forms will provide prompts and request additional information that may be useful and/or needed, and that the author is not aware of at the time. Project-specific field forms may be generated or existing forms may be modified to meet specific project needs. As required, client-supplied forms may be substituted.
- Appropriate header information documented on each page, including project title, project number, date, weather conditions, changes in weather conditions, other persons (if any) in the field party, and author. The specific information requested depends on the nature of the work being performed and on the form being used. Information fields that are not applicable should be noted "N/A" or with other appropriate notations.
- Field documentation entries using indelible ink.
- Legible data entries. A single line should be drawn through incorrect entries and the corrected entry should be written next to the original strikeout. Strikeouts are to be initialed and dated by the originator.
- Applicable units of measurement with entry values.
- Field records maintained in project files.

4.1 Documentation Entries

A chronology of field events will be recorded. General entry requirements include:

- Visitors to the site, including owner and regulatory representatives;
- Summary of pertinent project communications with the client, regulators, or other site visitors;
- Other contractors working on site;
- A description of the day's field activities, in chronological sequence using military time notation (e.g., 9:00 am: 0900, and 5:00 pm: 1700);

Appendix D – Sampling and Analysis Plan

- If applicable, calibration of measuring and test equipment and identification of the calibration standard(s) and use of a Calibration Log, if available, with cross-reference entered into the field book;
- Field equipment identification, including type, manufacturer, model number, or other specific information;
- General weather conditions, including temperature, wind speed, and direction readings, including time of measurement and units;
- Safety and/or monitoring equipment readings, including time of measurements and units;
- Presence of vessels/ship at the dock or in nearby vicinity, including time of arrival and departure;
- If applicable, reference in the field notebook to specific forms used for collection of data;
- Subcontractor progress and/or problems encountered;
- Changes in the scope of work; and
- Other unusual events.

4.2 Specific Requirements

Sample Collection. Sample collection data will be documented in a bound field book and/or on a sample collection form. Where both are being used, information contained in one is cross-referenced to the other. Entries include:

- Sample identification number, location taken, depth interval, sample media, sample preservative, collection time, and date;
- Sample collection method and protocol;
- Physical description of the sample;
- Quality-control-related samples collected (e.g., duplicates, blinds, trip blanks, field blanks);
- Container description and sample volume;
- Pertinent technical data such as headspace reading;
- Pertinent technical comments; and
- Identification of personnel collecting the sample.

Sample Labeling. Sample labels must be prepared and attached to sample containers. Labels will either be provided by the laboratory performing the analyses or will be generated internally. The information to be provided includes:

- Sample identification number;
- Sample date and collection time;

Appendix D – Sampling and Analysis Plan

- Physical description of the sample (e.g., water, sediment, etc.);
- Analytical parameters;
- Preservatives, if present;
- Sample location; and
- Client.

Core Logs. Surface and subsurface sediment samples are to be recorded in bound field books. Sediment logging information will be recorded on a core log sheet (Figure D-1). Personnel completing the log are to supply the following information:

- Names(s) of personnel logging sampling;
- Administrative and technical information included in the header;
- Types of equipment used;
- Subcontractor/driller used;
- Descriptions of subsurface materials encountered and the number and type of samples collected, if any;
- Subsurface exploration depth and units of measure;
- Length of recovery;
- Sample type and sample number for geotechnical or analytical samples collected (these data are also to be entered on the sample collection log, if used, and the sample label);
- Classification standard protocol used, if any;
- Narrative description of the sediment (using standard classification system) and other pertinent information;
- Description of consistency of cohesive sediments; and
- PID measurements.

Equipment Calibration Documentation. If field equipment requiring calibration is used, calibration will be performed on field parameter probes at the beginning of each day of intended use. Subsequent calibration during the day will be performed if needed (e.g., if an instrument malfunctions).

Records must be maintained for each piece of calibrated measuring and test equipment and each piece of reference equipment. The records must indicate that established calibration procedures have been followed.

Appendix D – Sampling and Analysis Plan

Records for periodically calibrated equipment must include the following minimum information:

- Type and identification number of equipment;
- Calibration frequency and acceptance tolerances;
- Calibration dates;
- The individual and organization performing the calibration;
- Reference equipment and/or standards used for calibration;
- Calibration data;
- Certificates or statements of calibration provided by manufacturers and external organizations; and
- Documentation of calibration acceptance or failure and of repair of failed equipment.

An individual file folder should be established to maintain records for each piece of measuring and testing equipment. Equipment calibration files should contain an equipment calibration and maintenance record, calibration data forms and/or certification of calibration provided by manufacturers or external organizations, and notice of equipment calibration failure.

Measuring and testing equipment used for field investigations will typically be calibrated as part of operational use. For this equipment, records of the calibrations or checks will be documented as part of the test data (e.g., in the field notebook). Equipment-specific forms may also be developed. These records should include information similar to that required for periodically calibrated equipment. Documentation related to malfunctioning equipment or equipment that fails calibration should also be included in the individual equipment file.

Calibration files for equipment requiring periodic calibration should be sent with equipment that is transferred to allow a continuously updated record to be maintained. Recalibration of sensitive equipment should be performed following the transfer. When measuring and testing equipment is rented or leased, procurement documents must specify that a current certificate of calibration must accompany the equipment. This certificate must be maintained with the project documentation calibration records.

5.0 Sample Containers and Handling

5.1 Container Requirements

Requirements for sample containers are given in Tables D-1 and D-2. Containers will be supplied by the analytical laboratory. The laboratory will certify that all sample containers were prepared according to standard EPA protocol.

Appendix D – Sampling and Analysis Plan

5.2 Labeling Requirements

A sample label will be affixed to each sample container before sample collection. The information to be included on the sample label is as follows:

- Project identification number;
- Sample number;
- Initials of person collecting the sample;
- Date and time of sample collection; and
- Type of preservative (if any).

5.3 Packaging and Shipping Requirements

The maximum hold time for sediment and surface water samples analyzed by EPA Method 8260 is 14 days. Samples will be sampled and preserved in accordance with Tables D-1 and D-2 and will be submitted to the laboratory within the acceptable hold time, taking into account shipping time, laboratory business hours, etc. To the extent possible, samples will be shipped to the laboratory within 24 hours of sample collection. Samples will be packed with ice (or blue ice) to maintain a shipment cooler temperature of 4 degrees Celsius (°C) or below and will be shipped overnight for next day delivery to the laboratory. One copy of the chain-of-custody form will be placed in a sealed plastic bag taped to the inside of the cooler lid.

6.0 Decontamination Procedures

Consistent decontamination procedures will be used for sampling. The objectives of decontamination are to prevent the introduction of contamination into samples from sampling equipment or other samples, to prevent contamination from leaving the site via sampling equipment or personnel, and to prevent exposure of field personnel to contaminated materials.

6.1 Personnel Decontamination

Personnel decontamination procedures depend on the level of protection specified for a given activity. The site health and safety plan identifies the appropriate level of protection for each type of field work involved in this project. Regardless of the level of protection required, field personnel should thoroughly wash their hands and faces before taking any work breaks and at the end of the day.

6.2 Sampling Equipment

Decontamination procedures are designed to remove trace level contaminants from sampling equipment to prevent the cross contamination of exploration locations and samples. The sediment coring device shall be

Appendix D – Sampling and Analysis Plan

decontaminated using high-pressure washing, steam cleaning, or cleaning with detergent (see below) before use and between locations.

To prevent cross contamination between sampling events, clean dedicated sampling equipment will be used for each sampling event and discarded or cleaned after use. Cleaning of non-disposable items will consist of washing in a detergent (e.g., Alconox®) solution, rinsing with tap water, followed with a deionized water rinse.

7.0 Investigation Derived Waste Handling

As discussed in Sections 2.2 and 2.3, sediment cores or grab samples not meeting acceptance criteria may be emptied overboard the vessel. Sediments that have been brought to shore for processing, as well as equipment decontamination water, will be considered investigation-derived waste (IDW). IDW will be placed in Department of Transportation (DOT)-approved drums. Each drum will be labeled with the project name, general contents, and date. The drummed IDW will be stored at terminal drum storage area. The selected disposal option will be determined based on analytical results on the samples from the explorations. In general, the drummed soil/sediment/water will be handled in the same manner as excavated soil or dredged sediment.

Disposable items, such as gloves, protective overalls (e.g., Tyvek®), paper towels, etc., will be placed in plastic bags after use and deposited in trash receptacles for disposal.

8.0 Quality Assurance Plan

The purpose of the Quality Assurance Plan (QAP) is to specify procedures and methods for office and field documentation, sample handling and custody, recordkeeping, equipment handling, and laboratory analyses that will be used during sampling and analysis.

8.1 Quality Assurance Objectives for Data Management

The general quality assurance (QA) objectives for this project are to develop and implement procedures for obtaining and evaluating data of a specified quality that can be used to evaluate sediment conditions. To collect such information, analytical data must have an appropriate degree of accuracy and reproducibility, samples collected must be representative of actual field conditions, and samples must be collected and analyzed using unbroken chain-of-custody procedures.

Method reporting limits and analytical results will be compared to action levels for each parameter in media of concern. The sediment screening criteria presented in Section 3.1 of the Work Plan text were reviewed in the development of the Work Plan SAP in order to establish reasonable laboratory reporting limits for the

Appendix D – Sampling and Analysis Plan

proposed sediment investigation. Reporting limits for surface water samples are consistent with reporting limits for the site groundwater monitoring program. The sediment and surface water reporting limits, listed in Table D-3, are the expected reporting limits, based upon laboratory calculations and experience. If site conditions are such that reporting limits exceed screening levels, additional work may be required to evaluate an acceptable alternative, including reanalysis or resampling.

Specific QA objectives are as follows:

1. Establish sampling techniques that will produce analytical data representative of the media being measured.
2. Collect and analyze a sufficient number of duplicate samples to establish sampling precision. Laboratory duplicates of the same sample will provide a measure of precision within the sample (sample homogeneity).
3. Analyze a sufficient number of analytical duplicate samples to assess the performance of the analytical laboratory.
4. Analyze a sufficient number of blank, standard, duplicate, spiked, and check samples within the laboratory to evaluate results against numerical QA goals established for precision and accuracy.

Precision, accuracy, representativeness, completeness, and comparability parameters used to indicate data quality are defined below. Tables D-4 and D-5 list the QA samples that will be collected as part of the sediment and surface water investigation.

8.1.1 Precision

Precision is a measure of the reproducibility of data under a given set of conditions. Specifically, it is a quantitative measure of the variability of a group of measurements compared to their average value. For duplicate measurements, precision can be expressed as the relative percent difference (RPD). Analysis of field duplicate sample will serve to measure the precision of sampling. In addition, a minimum of one laboratory duplicate will be analyzed per batch of samples.

8.1.2 Accuracy

Accuracy is the measure of error between the reported test results and the true sample concentration. True sample concentration is never known due to analytical limitations and error. Consequently, accuracy is inferred from the recovery data from spiked samples.

Because of difficulties with spiking samples in the field, the laboratory will spike samples. The laboratory shall perform sufficient spike samples of a similar matrix (sediment) to allow the computation of the

Appendix D – Sampling and Analysis Plan

accuracy. One matrix spike sample (MS) sample and one matrix spike duplicate (MSD) sample will be analyzed per sample batch.

Perfect accuracy is 100 percent recovery.

8.1.3 Representativeness

Representativeness is a measure of how closely the results reflect the actual concentration of the chemical parameters in the medium sampled.

Sampling procedures, as well as sample-handling protocols for storage, preservation, and transportation, are designed to preserve the representativeness of the samples collected. Proper documentation will confirm that protocols are followed. This helps to assure the sample identification and integrity.

Laboratory method blanks will be run in accordance with established laboratory protocols.

8.1.4 Completeness

Completeness is defined as the percentage of measurements, made which are judged to be valid measurements. The completeness goal is essentially that a sufficient amount of valid data be generated to allow for the evaluation of site cleanup.

8.1.5 Comparability

Comparability is a qualitative parameter expressing the confidence with which one data set can be compared with another. The objective of this QAP is to assure that all data developed during the sampling are comparable. Comparability of the data will be assured by using EPA-defined procedures which specify sample collection, handling, and analytical methods.

8.1.6 Documentation

Essentially EPA Level II documentation will be generated during sampling/analysis. This includes any 24-turnaround analyses requested of the laboratory. This level of documentation is generally considered legally defensible and consists of the following:

- Analytical Report
- Chain of Custody (COC) Form
- Method Blank (MB) Results
- Matrix Spike and Matrix Spike Duplicate (MS/MSD) Summary
- Reporting Limits (RL)

Appendix D – Sampling and Analysis Plan

- Laboratory Control Samples (LCS)
- Surrogate Recoveries
- Case Narrative, upon request or if applicable
- Corrective Action Reports, if applicable

8.2 Sampling Protocols

8.2.1 Methods

Sampling methods are presented in Sections 2 and 4. These procedures are designed to ensure that:

- Samples collected are consistent with project objectives; and
- Samples are identified, handled, and transported in a manner that does not alter the representativeness of the data from the actual site conditions.

Quality assurance objectives for sample collection will be accomplished by a combination of the following items:

- Following and documenting standardized procedures.
- **Laboratory QA.** Laboratory duplicate measurements will be carried out on at least five percent of all laboratory samples. Analytical procedures will be evaluated using the protocols of the analytical laboratory. These protocols can be submitted upon request.
- **Chain of Custody.** Described in Section 7.3.1.

8.2.2 Sample Containers, Preservation, and Holding Times

Sample containers, preservation, and holding times to be used for the project are listed in Tables D-1 and D-2.

8.3 Sample and Document Custody Procedures

The various methods used to document field sample collection and laboratory operation are presented below.

8.3.1 Field Chain-of-Custody Procedures

Sample chain of custody refers to the process of tracking the possession of a sample from the time it is collected in the field through the laboratory analysis. A sample is considered to be under a person's custody if it is:

Appendix D – Sampling and Analysis Plan

- In a person's physical possession;
- In view of the person after possession has been taken; or
- Secured by that person so that no one can tamper with the sample or secured by that person in an area which is restricted to authorized personnel.

A chain-of-custody form is used to record possession of a sample and to document analyses requested. Each time the sample bottles or samples are transferred between individuals, both the sender and receiver sign and date the chain-of-custody form. When a sample shipment is transported to the laboratory, a copy of the chain-of-custody form is included in the transport container (i.e., ice chest).

The chain-of-custody forms are used to record the following information:

- Sample identification number;
- Sample collector's signature;
- Date and time of collection;
- Description of sample;
- Analyses requested;
- Shipper's name and address;
- Receiver's name and address; and
- Signatures of persons involved in chain of custody.

8.3.2 Laboratory Operations

The analytical laboratory has a system in place for documenting the following laboratory information:

- Calibration procedures;
- Analytical procedures;
- Computational procedures;
- Quality control procedures;
- Bench data;
- Operating procedures or any changes to these procedures; and
- Laboratory notebook policy.

Laboratory chain-of-custody procedures provide the following:

Appendix D – Sampling and Analysis Plan

- Identification of the responsible party (sample custodian) authorized to sign for incoming field samples and a log consisting of sequential lab-tracking numbers; and
- Specification of laboratory sample custody procedures for sample handling, storage, and internal distribution for analysis.

8.3.3 Corrections to Documentation

Original data are recorded in field notes and on chain-of-custody forms using indelible ink. Documents will be retained even if they are illegible or contain inaccuracies that require correction.

If an error is made on a document, the individual making the entry will correct the document by crossing a line through the error, entering the correct information, and initialing and dating the correction.

8.4 Equipment Calibration Procedures and Frequency

Instruments and equipment used during this project will be operated, calibrated, and maintained according to the manufacturer's guidelines and recommendations. Operation, calibration, and maintenance will be performed by laboratory personnel fully trained in these procedures.

The PID used on-site will be calibrated on a daily basis according to the manufacturer's specifications. The PID generally utilizes a 10.2 eV probe and is calibrated using a manufacturer-supplied standard gas (100 ppm isobutylene).

8.5 Analytical Procedures

Sediment and surface water samples will be analyzed for VOCs using EPA Method 8260B. Sediment samples will also be analyzed for TOC by Method 9060A.

8.6 Data Reduction, Validation, and Reporting

Reports generated in the field and laboratory will be included with project reports.

The Project Manager will assure validation of the analytical data. The laboratory generating analytical data for this project will be required to submit results that are supported by sufficient backup and quality assurance/quality control (QA/QC) data to enable the reviewer to determine the quality of the data. Validity of the laboratory data will be determined based on the objectives outlined in Section 7.1 — Quality Assurance Objectives for Data Management, and Section 7.8 — Data Measurement Assessment Procedures. Data validity will also be determined based upon the sampling procedures and documentation outlined in Sections 7.1 and 7.3. Upon completion of the review, the Project Manager will be responsible for assuring development of a QA/QC report on the analytical data. Data will be stored and maintained

Appendix D – Sampling and Analysis Plan

according to the standard procedures of the laboratory. The method of data reduction will be described in the final report.

8.7 Performance Audits

Performance audits are an integral part of an analytical laboratory's standard operating procedures and are available upon request.

8.8 Data Measurement Assessment Procedures

The quality of the data will be assessed based on precision, accuracy, and completeness. Procedures to compute each are discussed below.

8.8.1 Precision

The RPD is used to assess the precision of the analytical method and is calculated using the following equation:

$$(1) \quad RPD = \frac{X_s - X_d}{\frac{(X_s + X_d)}{2}} \times 100\%$$

where:

X_s = analytical result of the sample

X_d = analytical result of the duplicate sample

8.8.2 Accuracy

The accuracy of the data set is determined from the analysis of spiked samples. The accuracy is calculated using the following equation:

$$(2) \quad A = \frac{(X_{ss} - X_s)}{T} \times 100\%$$

where:

A = accuracy

X_{ss} = analytical result obtained from the spiked sample

X_s = analytical result obtained from the sample

T = true value of the added spike

The overall accuracy is the arithmetic mean of all the spiked samples.

Appendix D – Sampling and Analysis Plan

8.8.3 Completeness

Completeness (percent complete, or PC) of the data is determined by the following equation:

$$(3) \quad PC = \frac{\text{Number of samples with acceptable data}}{\text{Number of samples collected}} \times 100\%$$

8.9 Corrective Actions

The quality assurance sample results will be evaluated along with the project sample analytical results to determine if the complete data package is acceptable for the intended use. The results of an individual quality assurance sample/parameter may be out of acceptable control limits, yet the dataset is still considered of good quality if QA parameters indicate that the accuracy and precision of the overall analysis is acceptable. If the quality control audit detects unacceptable analysis accuracy and/or precision, the Project Manager will be responsible for developing and initiating corrective action. Corrective action may include the following:

- Reanalyzing the samples, if holding time criteria permit;
- Resampling and analyzing;
- Evaluating and amending sampling and analytical procedures; and
- Accepting data and acknowledging level of uncertainty or inaccuracy by flagging the data.

If the results of the quick turn-around analysis samples fail the QA/QC audit (i.e., the body of QA/QC data do not confirm the accuracy and/or precision of the analysis), then corrective actions will also be taken as listed above. NuStar will have the opportunity to conference with Ecology upon receipt of the rush turnaround results, and the usability of the data, as well as any corrective actions needed, will be evaluated at that time.

8.10 Quality Assurance Reports

A QA review will be conducted that presents a QA/QC evaluation of the data collected during the sampling activities for inclusion in the final report. In addition to an opinion regarding the validity of the data, the QA/QC evaluation will address the following:

- Any adverse conditions or deviations from the SAP;
- Assessment of analytical data for precision, accuracy, and completeness;
- Significant QA problems and recommended solutions; and
- Corrective actions taken for any problems previously identified.

Table D-1
 Sediments – Analytical Methods – Sample Handling and Container Requirements
 SAP

Analysis	Method	Container	Preservative	Storage Temperature	Holding Time
VOC	EPA Method 8260B	6 or 8 oz glass jar.	N/A	4°C	14 days
TOC	EPA 9060A	6 or 8 oz glass jar.	N/A	4°C	14 days
Grain Size Analysis	ASTM C136/C117 Methods	6 or 8 oz glass jar.	N/A	N/A	N/A

Notes:

1. Grain-size analysis may be performed, pending results of VOC analysis.
2. VOC = Volatile organic compound; TOC = Total organic carbon.
3. N/A = not applicable.
4. °C = degrees Celsius

Table D-2
 Surface Water – Analytical Methods – Sample Handling and Container Requirements
 SAP

Analysis	Method	Container	Preservative	Storage Temperature	Holding Time
VOC	EPA Method 8260B	VOA glass vial w/Teflon lined septum	HCL	4°C	14 days

Notes:

1. VOC = Volatile organic compound.
2. HCL = hydrochloric acid
3. VOA = Volatile Organic Analysis

Table D-3
Analytical Methods — Sediment Reporting Limit Goals
SAP

Methods	Analyte	Sediment [mg/kg]	Surface Water µg/l
VOCs, EPA 8260	1,1,2,2-Tetrachloroethane	0.005	0.5
	1,2-Dichlorobenzene	0.005	0.5
	1,3,5-Trimethylbenzene	0.005	0.5
	2+4-Chlorotoluene	0.005	0.5
	Bromobenzene	0.005	0.5
	n-Butylbenzene	0.005	0.5
	n-Propylbenzene	0.005	0.5
	O-Xylene	0.005	0.5
	p-Isopropyltoluene	0.005	0.5
	sec-Butylbenzene	0.005	0.5
	Styrene	0.005	0.5
	tert-Butylbenzene	0.005	0.5
	1,1,1,2-Tetrachloroethane	0.005	0.5
	1,1,1-Trichloroethane	0.005	0.5
	1,1,2-Trichloroethane	0.005	0.5
	1,1-Dichloroethane	0.0005*	0.5
	1,1-Dichloroethene	0.005	0.5
	1,1-Dichloropropene	0.005	0.5
	1,2,3-Trichlorobenzene	0.005	0.5
	1,2,3-Trichloropropane	0.005	0.5
	1,2,4-Trichlorobenzene	0.005	0.5
	1,2,4-Trimethylbenzene	0.005	0.5
	1,2-Dibromo-3-chloropropane	0.005	0.5
	1,2-Dibromoethane (EDB)	0.005	0.5
	1,2-Dichloroethane (DCA)	0.005	0.5
	1,2-Dichloropropane	0.005	0.5
	1,3-Dichlorobenzene	0.005	0.5
	1,3-Dichloropropane	0.005	0.5
	1,4-Dichlorobenzene	0.005	0.5
	2,2-Dichloropropane	0.005	0.5
	Benzene	0.005	0.5
	Bromochloromethane	0.005	0.5
	Bromodichloromethane	0.005	0.5
	Bromomethane	0.02	0.5
	Carbon Tetrachloride	0.005	0.5
	Chlorobenzene	0.005	0.5
	Chloroethane	0.005	0.5
	Chloroethane	0.005	0.5
	Chloroform	0.005	0.5
	Chloromethane	0.005	0.5
	cis-1,2-Dichloroethene	0.005	0.5
	cis-1,3-Dichloropropene	0.005	0.5
	Dibromochloromethane	0.005	0.5
	Dibromomethane	0.005	0.5
	Dichlorodifluoromethane	0.005	0.5
	Hexachlorobutadiene	0.005	0.5
	Methylene Chloride	0.005	0.5
	Naphthalene	0.005	0.5
	P,M-Xylene	0.005	0.5
	Tetrachloroethene (PCE)	0.005	0.5
Toluene	0.005	0.5	
trans-1,2-Dichloroethene	0.005	0.5	
trans-1,3-Dichloropropene	0.005	0.5	
Trichloroethene (TCE)	0.005	0.5	
Trichlorofluoromethane	0.005	0.5	
Vinyl Chloride	0.005	0.5	
1,4 - Dioxane	0.005	0.5	

Notes:

- * One applicable screening level value for 1,1-Dichloroethane is 0.00058 mg/kg. (SD EPA R5 ESL Sediment Screening Benchmark). Using their current instrument calibration, lab can meet reporting limits (RL) of 0.0005 (10 times below the standard RL for this analyte). All other screening levels are met using reporting limits for EPA Method 8260.
- BOLD** = Indicates Chemicals of Potential Concern (COPC) for Sediments

Table D-4
Sediment – Laboratory Quality Control Sample Analysis Summary
SAP

Analysis Type	Initial Calibration	Ongoing Calibration	Field Duplicate	MS/MSD	LCS/LCSD	Surrogate Spikes	Method Blank
Grain Size	Bi-annual	N/A	1 per 20 samples	N/A	N/A	N/A	N/A
VOCs*	Each Batch	Every 12 hours	1 per 20 samples*	1 per 20 samples*	1 per batch.	Every sample, standard and method blank.	1 per batch.
TOC	Each Batch	Every 15 samples	1 per 20 samples	1 per batch	1 per 10 samples	N/A	1 per batch.

Notes:

1. Calibration of drying ovens and scales are conducted bi-annually.
2. N/A = Not applicable
3. Initial calibrations are considered valid until the ongoing continuing calibration no longer meets method specifications. At this point, a new initial calibration is performed.
4. MS = Matrix Spike; MSD = Matrix Spike Duplicate
5. LCS = Laboratory Control Spike; LCSD = Laboratory Control Spike Duplicate
6. "Batch" indicates each group of samples received, or each group of 20 samples on a chain-of-custody.
7. VOC = Volatile organic compound; TOC = Total organic carbon.

Table D-5
 Surface Water – Laboratory Quality Control Sample Analysis Summary
 SAP

Analysis Type	Initial Calibration	Ongoing Calibration	Field Duplicate	MS/MSD	LCS/LCSD	Surrogate Spikes	Method Blank
VOCs*	Each Batch	Every 12 hours	one	1 per batch	1 per batch.	Every sample, standard and method blank.	1 per batch.

Notes:

1. Calibration of drying ovens and scales are conducted bi-annually.
2. N/A = Not applicable
3. Initial calibrations are considered valid until the ongoing continuing calibration no longer meets method specifications. At this point, a new initial calibration is performed.
4. MS = Matrix Spike; MSD = Matrix Spike Dt
5. LCS = Laboratory Control Spike; LCSD = Laboratory Control Spike Duplicate
6. "Batch" indicates each group of samples received, or each group of 20 samples on a chain-of-custody.
7. VOC = Volatile organic compound.

Visual Classification of Subsurface Core

Job _____
 Job No. _____
 Exploration No. _____
 Core No. _____
 Water Depth/Elevation of Core _____
 Cored Length (feet; from log) _____
 Core Recovery (feet) _____

Date _____
 Core Pushed By _____
 Core Logged By _____
 Type of Core Shelby Piston Core Other
 Diameter of Core (inches) _____
 Core Quality Good Fair Poor Disturbed
 Average % Compaction = _____

Theoretical Depth in () Actual Core Sections	Sample Interval	Sample Analytes	Classification and Remarks (Color, Consistency, Moisture, Grain Size, Sheen, Odor)

Figure I-3
 Subsurface Core Log Form

Attachment A

Surface Water Sampling – Supporting Information

Example of Expanded Aluminum Mesh Sheeting

