

PREPARED FOR:
PACCAR Inc

BY:
Shannon & Wilson, Inc.
400 N. 34th Street, Suite 100
Seattle, WA 98103

(206) 632-8020
www.shannonwilson.com

PUBLIC REVIEW DRAFT

Interim Action Work Plan

8801 EAST MARGINAL WAY S., TUKWILA, WASHINGTON

Agreed Order No 6069

Prepared for: PACCAR Inc

Subject: PUBLIC REVIEW DRAFT, INTERIM ACTION WORK PLAN,
8801 EAST MARGINAL WAY S., TUKWILA, WASHINGTON

Shannon & Wilson prepared this report and participated in this project as a consultant to PACCAR Inc. This report presents the Interim Action Work Plan for the property at 8801 East Marginal Way S., Tukwila, Washington, and was prepared by the undersigned. The findings, conclusions, and designs supersede those provided in the previous version of this Interim Action Work Plan.

We appreciate the opportunity to be of service to you on this project. If you have questions concerning this report, or we may be of further service, please contact us.

Sincerely,

SHANNON & WILSON, INC.

Scott W. Gaulke, PE, LHG
Vice President

Meg Strong, LG, LHG
Vice President

PJS:RBP:SKH:SWG:MJS/skh:rbp

EXECUTIVE SUMMARY

This report presents the interim action work plan (IAWP) for the property at 8801 East Marginal Way South (8801 site) in Tukwila, Washington. The 8801 site consists of both an upland portion (the 8801 property) and the adjoining sediments in the Lower Duwamish Waterway (LDW).

An approximately 5½ mile stretch of the LDW has been designated as a Superfund site by the U.S. Environmental Protection Agency (EPA). The Record of Decision (ROD) for the LDW Superfund site remediation was issued in November 2014 (EPA, 2014). The remedy for the sediment portion of the 8801 site is prescribed in the ROD. Dredging and enhanced monitored natural recovery have been selected as the remedy for the sediments adjoining the 8801 property. The sediment remedy will not be implemented until 2020 at the earliest, because a three-year pilot test began in 2017 to determine the effectiveness of enhanced monitored natural recovery in the stretch of the LDW that includes the 8801 site. The scope and details of the sediment remedy could change depending on the results of the pilot test. Remedial design will likely not begin until the sediment pilot test is over. Because the sediment remedial action associated with the 8801 site is not yet finalized, this report is called an interim action report. However, the remedial activities described in this report are the final actions for the upland portion of the 8801 site.

Washington State Department of Ecology (Ecology) is working with the EPA to identify and remove sources of ongoing contaminant contribution to the LDW. Since the 8801 property is adjacent to the LDW, the remedial actions detailed in this report are designed to be protective of the sediments and surface water of the LDW. In 2017, Ecology provided LDW-specific preliminary cleanup levels (PCULs) that accounted for LDW-wide specific criteria that were expected to be protective of the sediments and surface water in the LDW. Ecology updated these values in 2018 (Ecology, 2018). The 2018 PCULs were used as the basis for determining the distribution of chemicals on the 8801 property and the areas that require remedial actions.

The upland portion of the 8801 site occupies 24.30 acres on the east bank of the LDW. The property is zoned manufacturing industrial center/heavy industry by the City of Tukwila. The existing buildings include an administration building located in the southeast corner of the property, a large warehouse building that covers much of the east and mid portions of the property, a former boiler and powerhouse building located on the northwest side of the warehouse building; and a smaller warehouse located in the northwest portion of the

property. The small warehouse building contains a groundwater air sparge/soil vapor extraction (AS/SVE) remediation system, in operation since 2004.

The upland portion of the 8801 site is owned by CenterPoint 8801 Marginal LLC (CenterPoint). The 8801 property has been leased to Insurance Auto Auctions, Inc. (IAAI) since 2004. IAAI stored and auctioned off insurance write-off vehicles; IAAI vacated the 8801 property in 2018 but continue to operate a stormwater management system on the 8801 property. CenterPoint plans to redevelop the property. The redevelopment is slated for late 2019 through 2021. The redevelopment plans include demolition of all the existing buildings, except the smaller warehouse in the northwest portion of the property and construction of an approximately 414,400-square-foot building for industrial use and trailer storage. The design of the building includes importing fill to raise the floor level approximately 4 feet above existing grade to allow direct truck loading. Remedial actions described in this report consider protection of future occupants of the new building.

The 8801 property is predominately contaminated with halogenated volatile organic compounds (VOCs) in groundwater on the northern and western side of the property; gasoline-range hydrocarbons in the soil and groundwater in the northwestern corner of the property and in a small area of soil beneath the large warehouse building on the east of the property; lead, arsenic, copper, and polychlorinated biphenyls (PCBs) in soil in areas of fill in the southwestern portion of the property; and PCBs and copper in fill at the southern boundary of the property. These chemicals are associated with former industrial activities on the 8801 property, placement of fill by various former owners, and activities by the neighboring southern property owner.

Remedial options considered in this report are primarily focused on remediation of soil and groundwater and reducing the impact of halogenated VOCs on air. Soil cleanup levels (CULs) address contaminant leaching from soil to groundwater and are designed to protect the surface water and sediments of the LDW and the air. Groundwater CULs are based on human consumption of organisms that reside in the LDW. Remediation levels are proposed to meet groundwater CULs at the property points of compliance located along the western edge of the 8801 property, the point at which the groundwater enters the LDW.

Remediation of Soil

The soil remedial actions that were considered included:

- Maintaining the existing cap and using institutional controls to manage human contact with soil and prevent leaching of contaminants in the soil to groundwater,
- Property wide excavation of all chemicals of concern (COCs) that exceed the CULs, or

- Two scenarios for excavation of hotspots, concentrated areas of COCs exceeding the applicable CULs.

The property wide capping and institutional controls option does not provide for a reasonable restoration time; therefore, it was not selected as a viable remedial alternative. The property-wide excavation/disposal option has high short-term risks, difficulty of implementation, and its cost is disproportionately high compared to its benefit; therefore, it was not selected as a viable remedial alternative.

The hotspot excavation scenarios would result in removal of much of the mass of the COCs on the 8801 property. Both hotspot excavation scenarios would require institutional controls to prevent the soil remaining outside of the hotspot areas from serving as a source of contamination to groundwater. The selected hotspot scenario that resulted in six soil excavations was chosen because it would provide for the removal of much of the mass of the COCs without the greater cost associated with a series of additional small excavations in the second scenario. The selected remedy will reduce the overall mass of COCs in six hotspots; the excavation removes a significant mass of COCs and reduces the potential for construction worker exposure at the 8801 property.

Groundwater Remediation

The groundwater halogenated VOC plume extends over much of the western half of the 8801 property. Across most of the plume, the COCs change as the chemicals naturally degrade and move westwards with the flow of groundwater. A combination of groundwater remedial actions was considered to address each portion of the plume.

Groundwater remedial alternatives considered for each portion of the plume included:

- Trichloroethene (TCE) impacted soil in the northern portion of the property:
 - Excavation of TCE-containing soil at concentrations above the CUL, or
 - Excavation of TCE-containing soil at concentrations above the remediation level.
- Halogenated VOC plume in the north and central portion of the property:
 - Allowing the natural degradation processes already occurring in groundwater to continue, or
 - Injection of carbon and bacteria to enhance the natural breakdown of halogenated VOCs.
- Halogenated VOC plume west of the AS/SVE system:
 - Allowing the natural degradation processes to continue in groundwater, or
 - The use and extension of the existing AS/SVE system.

Excavation of TCE-containing soil to the remediation level would remove 85% of the mass. The option to excavate to the CUL would require a much larger excavation which was determined to be disproportionate to the benefit; therefore, it was not selected as a viable remedial alternative.

The options which included allowing natural degradation processes to continue in groundwater were lower cost, but resulted in longer remediation timeframes, lower overall protectiveness, and lower effectiveness; therefore, they were not selected as viable remedial alternatives.

The selected remedy combination consists of excavating TCE-containing soil at concentrations above the remediation level in the northern portion of the property, injection of carbon and bacteria to enhance the natural breakdown of the halogenated VOCs in the north and central portion of the property, and extension of the existing AS/SVE system west of the current alignment. PCBs are present in groundwater within a limited area of the north portion of the property. The remedial option selected to address the PCBs in groundwater in this area is removal of PCB-containing caulking from surface joints that is likely serving as the source of PCBs in groundwater.

Total petroleum hydrocarbons (TPH) are present in soil and groundwater and halogenated VOCs are also present in groundwater in the northwest corner of the 8801 property. Three remedial alternatives were considered to address TPH and VOCs in this area:

- Pump-and-treat impacted groundwater,
- Installation of a permeable reactive barrier consisting of compounds for the chemicals to adsorb to and prevents their migration off the property, or
- Chemical injection to enhance the naturally occurring breakdown of the COCs.

The pump-and-treat and permeable reactive barrier options were eliminated as viable remedial options because they would achieve lower overall protectiveness, lower effectiveness, and would require longer restoration timeframes.

The selected remedy for this area was chemical injection of an oxygen-containing compound to accelerate the naturally occurring remediation of the TPH and halogenated VOCs that degrade more rapidly in an oxygen-rich environment. To mitigate the potential for the injected chemicals to enter the LDW, a barrier will be installed adjacent to the pile wall that separates the 8801 property from the LDW and around the outfall that discharges through the pile wall.

Air Impacts

The western footprint of the proposed new building overlies part of the halogenated VOC groundwater plume. The concentrations found in the groundwater prior to the start of remediation can result in potential impact to indoor air. Since the remediation of the halogenated VOC plume will not be completed prior to the proposed construction, sub-slab depressurization beneath the affected area of the western side of the building has been selected to remove the pathway to the indoor air of the building.

Monitoring

Soil and groundwater will be monitored during remedial action activities. Soil will be excavated until the remediation levels are reached. The remaining soil will be evaluated for attainment of the CULs based on groundwater concentrations of COCs since soil CULs are based on the protection of groundwater. Groundwater monitoring will be used to determine if additional injections are required. On completion of the active remediation, groundwater monitoring will continue until the CULs are being achieved at the conditional point of compliance for the 8801 property.

An institutional control in the form of a restrictive covenant will be required for the 8801 property to ensure that maintenance of the surface cover is undertaken to reduce stormwater infiltration and any leaching of the soil COCs into groundwater and to ensure that groundwater is not used for drinking water.

The cleanup actions described in this IAWP will be undertaken after formal review has been completed and the actions are accepted by Ecology. An engineering design report that provides additional details and design of the remedial actions will be provided for Ecology review after the IAWP is approved. After Ecology approval, it is proposed to implement the remedial actions within one year.

CONTENTS

- 1 Introduction1
- 1.1 Background1
- 1.2 Objective2
- 1.3 Report Organization2
- 2 Overview3
- 2.1 Physical Setting3
- 2.2 Property Description3
- 2.3 Property History5
- 2.4 Geology and Hydrogeology6
 - 2.4.1 Site Geology6
 - 2.4.2 Site Hydrogeology7
 - 2.4.3 Tidal Influence8
- 2.5 Previous Investigation and Remedial Activities8
 - 2.5.1 Investigations – 1986 to 20098
 - 2.5.2 Investigations – After 200910
 - 2.5.3 Past Remedial Activities11
- 3 Conceptual Site Model (CSM)13
- 3.1 Distribution of Contaminants of Concern (COCs)13
 - 3.1.1 Petroleum Hydrocarbon-Related Compounds14
 - 3.1.2 Metals15
 - 3.1.3 Halogenated Volatile Organic Compounds (VOCs)16
 - 3.1.4 Polychlorinated Biphenyls (PCBs) and Dioxins/Furans16
 - 3.1.5 Bis(2-ethylhexyl)phthalate17
- 3.2 Conceptual Site Model (CSM)17
- 3.3 Contaminant Sources17
 - 3.3.1 Potential Receptors18
 - 3.3.2 Transport Mechanisms19
- 4 Cleanup Standard20
- 4.1 Cleanup Levels (CULs)20
 - 4.1.1 Soil21

CONTENTS

- 4.1.2 Soil Remediation Levels22
- 4.1.3 Groundwater.....23
- 4.1.4 Halogenated Volatile Organic Compounds (VOCs).....23
- 4.1.5 Groundwater Restoration Timeline.....24
- 4.2 Point of Compliance (POC)24
 - 4.2.1 Soil25
 - 4.2.2 Air.....25
 - 4.2.3 Groundwater.....25
- 4.3 Areas of Concern.....26
- 5 Description of Remedial Alternatives and Selection.....27
 - 5.1 Remedial Action Objectives (RAOs).....27
 - 5.2 General Response Actions28
 - 5.3 Summary of Alternatives28
 - 5.3.1 Soil29
 - 5.3.2 Groundwater.....29
 - 5.3.3 Northwest Area31
 - 5.4 Evaluation of Alternatives33
 - 5.4.1 Model Toxics Control Act (MTCA) Threshold Requirements33
 - 5.4.2 Model Toxics Control Act (MTCA) Disproportionate Cost Analysis (DCA).....33
 - 5.5 Comparative Analysis of Alternatives34
 - 5.5.1 Soil35
 - 5.5.2 Groundwater.....37
 - 5.5.3 Northwest Area38
 - 5.6 Synergistic Effect of Selected Alternatives39
 - 5.6.1 Contingencies.....39
 - 5.6.2 Institutional Controls.....41
- 6 Compliance Monitoring and Schedule41
 - 6.1 Protection Monitoring42
 - 6.2 Performance Monitoring.....42
 - 6.2.1 Waste Profile for Off-Site Treatment or Disposal43

CONTENTS

6.2.2	Excavation Performance Monitoring.....	43
6.2.3	Performance Monitoring of the Suitability of Imported Fill Material and Compaction.....	44
6.2.4	Performance Monitoring of Air Sparge/Soil Vapor Extraction (AS/SVE), Enhanced Reductive Dechlorination (ERD), and In Situ Chemical Oxidation (ISCO) Groundwater Treatment Systems	45
6.3	Groundwater Performance and Confirmation Monitoring	45
6.4	Schedule for Implementation	46
7	Limitations	46
8	References	46
Exhibits		
	Exhibit 5-1: Combinations of Actions for Groundwater Remedial Alternatives	30
	Exhibit 5-2: Formula for Weighted Overall Benefit Score	35
	Exhibit 5-3: Formula for Benefit/Cost Ratio	35
Tables		
	Table 1: Cleanup Levels (2 pages)	
	Table 2: Soil Remediation Levels	
	Table 3: Soil Chemicals of Concern Mass Calculations	
	Table 4: Proposed Halogenated Volatile Organic Compounds Groundwater Remediation Levels	
	Table 5: Summary of Chemicals of Concern, Areas of Concern, and Selected Remedies	
	Table 6: Performance Monitoring	
	Table 7: Compliance Monitoring	

Figures

- Figure 1: Vicinity Map
- Figure 2: Key Site Features
- Figure 3: Proposed Development
- Figure 4: Groundwater Elevation, September 27, 2011 (Low Tide)
- Figure 5: Previous Excavation Locations
- Figure 6: Conceptual Site Model
- Figure 7: Proposed Remediation
- Figure 8: Performance and Compliance Monitoring Wells

Appendices

- Appendix A: Chemical of Concern Distribution Figures
- Appendix B: Air Exposure Calculations
- Appendix C: Disproportionate Cost Analyses Tables and Graphs

CONTENTS

ACRONYMS

1,1-DCA	1,1-dichloroethane
Amec	Amec Earth and Environmental, Inc./Environment and Infrastructure, Inc.
Anchor	Anchor Environmental, LLC
AO	Agreed Order
AS/SVE	air sparge/soil vapor extraction
bgs	below ground surface
BMPs	Best Management Practices
Boeing	The Boeing Company
CenterPoint	CenterPoint 8801 Marginal LLC
COCs	chemicals of concern
cPAHs	carcinogenic polycyclic aromatic hydrocarbons
CSM	conceptual site model
CUL	cleanup level
DCA	Disproportionate Cost Analysis
Ecology	Washington State Department of Ecology
EPA	U.S. Environmental Protection Agency
ERD	enhanced reductive dechlorination
FFS	Focused Feasibility Study
FS	feasibility study
HASP	health and safety plan
IAAI	Insurance Auto Auctions, Inc.
IAWP	interim action work plan
ISCO	in situ chemical oxidation
Kennedy/Jenks	Kennedy/Jenks Consultants
LDW	Lower Duwamish Waterway
Leidos	Leidos, Inc.
MCH	Merrill Creek Holdings, LLC
mg/kg	milligrams per kilogram
MNA	monitored natural attenuation
Monsanto	Monsanto Chemical Company
MSL	mean sea level
MTCA	Model Toxics Control Act
NOAA	National Oceanic and Atmospheric Administration
NPDES	National Pollution Discharge Elimination System
PACCAR	PACCAR Inc
PAHs	polycyclic aromatic hydrocarbons
PCBs	polychlorinated biphenyls
PCE	tetrachloroethene

ACRONYMS

PCULs	preliminary cleanup levels
POCs	points of compliance
PQL	practical quantitation limit
RAOs	Remedial Action Objectives
REL	remediation level
RI	Remedial Investigation
ROD	Record of Decision
SAP	sampling and analysis plan
SVOCs	semi-volatile organic compounds
SWPPP	Stormwater Pollution Prevention Plan
TCE	trichloroethene
TEQ	toxicity equivalent quotient
TPH	total petroleum hydrocarbons
USTs	underground storage tanks
VOCs	volatile organic compounds
WAC	Washington Administrative Code
Windward	Windward Environmental LLC
µg/L	micrograms per liter

1 INTRODUCTION

This report presents the IAWP for the property at 8801 East Marginal Way South (8801 site) in Tukwila, Washington (Figure 1). The 8801 site consists of both an upland portion (the 8801 property) and the adjoining sediments in the LDW. The 8801 site is subject to two separate Agreed Orders (AOs): AO No. 6069, which applies to the 8801 property, and AO No. 3599, which applies to the sediments. This report fulfills the IAWP requirements in AO No. 6069.

An approximately 5½ mile stretch of the LDW has been designated as a Superfund site by the EPA. The ROD for the LDW Superfund site remediation was issued in November 2014 (EPA, 2014). The remedy for the sediment portion of the 8801 site is prescribed in the ROD. Dredging and enhanced monitored natural recovery have been selected as the remedy for the sediments adjoining the 8801 property. The sediment remedy will not be implemented until 2020 at the earliest, because a three-year pilot test began in 2017 to determine the effectiveness of enhanced monitored natural recovery in the stretch of the LDW that includes the 8801 site. The scope and details of the sediment remedy could change depending on the results of the pilot test, and remedial design will likely not begin until the pilot test is over. Because the sediment remedial action associated with the 8801 site is not yet finalized, this report is called an interim action report. However, the remedial activities described in this report are the final actions for the upland portion of the 8801 site.

Ecology is working with the EPA to identify and remove sources of ongoing contribution to the LDW. Since the 8801 property is adjacent to the LDW, the remedial actions detailed in this report are designed to be protective of the sediments and surface water of the LDW. This report was prepared in accordance with the Model Toxics Control Act (MTCA) and Ecology's corresponding Cleanup Regulation (Washington Administrative Code [WAC] Chapter 173-340) (Ecology, 2013).

1.1 Background

A Remedial Investigation (RI) report for the 8801 upland area, dated May 18, 2011, was approved by Ecology in 2012 (Amec Earth and Environmental, Inc. [Amec], 2011). The RI report included a comprehensive summary of past investigation and remedial actions that had been previously completed on the 8801 property and described the areas of concern at the time of writing. In 2011, when the RI report was generated, the values used to screen the chemicals were different from the current screening levels. Based on the findings in the RI report, a Focused Feasibility Study (FFS) data gaps investigation was undertaken in September and October 2011. The information from the 2011 investigation was

incorporated into an FFS report. In 2013, the final FFS report for the 8801 property was submitted to Ecology (Amec, 2013). The 2013 FFS report contained values used to screen the chemicals (both from the investigation in 2011 and from previous investigations) that are different from the current screening levels.

In 2017, Ecology provided LDW-specific PCULs that account for LDW-wide specific criteria (such as total organic carbon concentration), and that are protective of the sediments and surface water in the LDW and updated the values in 2018 (Ecology, 2018). In 2019, groundwater data was collected from the 8801 property. The groundwater samples were collected to provide updated information for the feasibility study (FS) and this report and to provide baseline data in advance of proposed redevelopment (discussed later).

Data from previous investigations at the 8801 property including the 2019 groundwater sampling was screened against Ecology's PCULs and COCs and areas of concern were established. The COCs and areas of concern were used as the basis for the remedial alternative analysis and selection presented in a Public Review Draft FS (Shannon & Wilson, 2019).

The 8801 property predominately is contaminated with halogenated VOCs in groundwater on the north and western side of the property; gasoline-range hydrocarbons in the soil and groundwater in the northwestern corner of the property and in the soil in a limited area beneath a warehouse building; lead, arsenic, copper, and PCBs in soil in areas of fill in the southwestern portion of the property; and PCBs and copper in fill at the southern boundary of the property. The chemicals are associated with previous operations at the 8801 property that included truck assembly and operations from their southern neighbor, and placement of fill by both Kenworth a subsidiary of PACCAR Inc (PACCAR) and the former Monsanto Chemical Company (Monsanto) who previously owned the southern port of the 8801 property.

1.2 Objective

The objective of this IAWP is to:

- Present the proposed approach for remediation of soil, groundwater, and protection of the indoor air routeway on the upland portion of the 8801 site. The remediation of the sediment portion within the LDW will comply with the LDW ROD requirements and will be presented separately.

1.3 Report Organization

This document presents a history of the property, a synopsis of various environmental investigations and remedial action previously undertaken, the distribution of COCs and

areas of concern, a summary of the applicable technologies and selected remedial alternatives, and the schedule for implementation of the remedial action. The report comprises the following sections:

- Section 1 introduces the background for the report and lays out the objectives.
- Section 2 discusses the site setting, history, and a synopsis of past investigations and remedial actions on and adjacent to the 8801 property.
- Section 3 presents a synopsis of the contamination associated with the 8801 property and discusses the conceptual site model (CSM); a framework for looking at the contamination, and how it might affect various receptors.
- Section 4 discusses the cleanup standards, which include CULs and points of compliance. It also addresses remediation levels that are interim levels used to achieve sufficiently low values to protect an exposure pathway, though greater than concentrations that must be achieved by the final cleanup.
- Section 5 summarizes the remedial alternatives presented in the FS and selection of the remedies.
- Section 6 discusses the activities associated with compliance monitoring and the schedule for implementing the remedial actions.
- Section 7 provides the report limitations.
- Section 8 lists references used in the report.

2 OVERVIEW

This section presents an overview of the 8801 property location and history and the geology and hydrogeology and summarizes past investigation and remedial activities on and adjacent to the property.

2.1 Physical Setting

The 8801 site is in the Green-Duwamish River Watershed, which drains approximately 483 square miles in northwestern Washington. The upland portion of the 8801 property lies adjacent to the LDW, approximately 4 miles upstream from the mouth of the River. The upland portion of the 8801 property is relatively flat, with a ground surface elevation of approximately 20 feet above mean sea level (MSL).

2.2 Property Description

The upland portion of the 8801 site occupies 24.30 acres on the east bank of the LDW at 8801 East Marginal Way South (King County parcel no. 5422600060), Tukwila, Washington

(Figure 2). The property is zoned manufacturing industrial center/heavy industry by the City of Tukwila.

The upland portion of the 8801 site is owned by CenterPoint. The 8801 property has been leased to IAAI since 2004. Until approximately September 2018, IAAI used the 8801 property to store and auction damaged and wrecked vehicles. Although IAAI is still the tenant, they removed all the stored and damaged vehicles from the 8801 property in August and September 2018. At the time of writing, IAAI is using part of the 8801 property for administrative purposes and is continuing to manage the stormwater system as a requirement of their discharge permit.

The existing buildings include an administration building located in the southeast corner of the property, a large warehouse building that covers much of the east and mid portions of the property that was used for storage of vehicles and conducting the auctions, a former boiler and powerhouse building located on the northwest side of the warehouse building and a smaller warehouse located in the northwest portion of the property. The smaller warehouse was formerly used for storage of cars; the cars were removed after the building was heavily damaged in a fire that occurred in 2014. The small warehouse building has been vacant since 2014, except for the AS/SVE remediation equipment, which is in the southeast corner of the building. The remainder of the 8801 property is paved and surrounded by a tall chain link electric fence. A metal former water tower lies within the northern central part of the property.

Two main storm systems drain the 8801 property and discharge to the LDW as the North Outfall (No. 1) and the Central Outfall (No. 2). The Central Outfall was previously known as the 8801 South Outfall. A middle outfall was plugged and closed in 2004. Stormwater system upgrades completed in 2007 included installation of filter and cyclone units to remove particulates prior to discharge at both existing outfalls. The principal northern drainage conveyance pipe was also relined by a process called slip-lining for much of its length in 2012. A King County storm drain, which conveys discharge from the King County Airport to an outfall at Slip 6 south of the property on the LDW, crosses the eastern portion of the 8801 property.

CenterPoint plans to redevelop the property once IAAI terminates the lease. The redevelopment is slated for late 2019 through 2021. The redevelopment plans include demolition of all the buildings except the smaller warehouse on the west of the 8801 property and construction of an approximately 414,400-square-foot building for industrial use and trailer storage. The design of the building includes importing fill to raise the floor level approximately 4 feet above existing grade to allow direct truck loading. The footprint of the development relative to existing buildings and monitoring wells is shown in Figure 3.

Located to the north are two parcels (0007400033 and 0001600014) owned by The Boeing Company (Boeing), one of which has been used for airplane manufacturing. To the south are two parcels (5422600010 and 5422600020). The western of these two parcels is owned by Container Properties LLC and is also leased to IAAI. IAAI used the western parcel for the storage of damaged and wrecked vehicles until 2018. The Museum of Flight Foundation owns the eastern parcel, uses the property to store airplanes, and recently developed the land with one building that is used for pilot training. The 8801 property is bounded to the east by East Marginal Way South and to the west by the LDW.

2.3 Property History

The 8801 property was originally comprised of the northern two-thirds of the current footprint. The northern portion of the 8801 property was developed in approximately 1929 and was purchased by Kenworth, a subsidiary of PACCAR in 1945. The stormwater system and main warehouse building were built around 1929 on this original footprint. The facility expanded westward toward the LDW between 1929 and the mid-1950s. In 1966, the southern one-third of the 8801 property was acquired from Monsanto. After the acquisition of the southern parcel, the southwestern corner of the southern property, which was previously part of the LDW, was filled and the southern stormwater system was constructed (Figure 2).

The western edge of the 8801 property has a sheet pile wall bulkhead built in approximately 1929 that extends along the northern two-thirds of the western edge of the 8801 property and to a depth of about 30 feet below ground surface (bgs). The sheet pile wall bends into the upland area of the 8801 property and extends approximately 100 feet to the east along the former southern property line. In the southwest corner of the 8801 property, a berm was built in approximately 1969 along the southern one-third of the western property boundary and to the east on the southwestern corner of the 8801 property. After the berm was constructed, approximately 10 feet of fill was placed on the east side of the embankment, bringing the ground surface to roughly its present grade. Riprap armor was placed on the two LDW-facing sides.

The 8801 property was used for the assembly of trucks under the Kenworth name. The trucks were mostly constructed in the main warehouse building, where three assembly lines were present. The remainder of the 8801 property was used for support services, such as a tire shop, maintenance shop, fiberglass shop, cafeteria, and administration. The surface of the 8801 property has been fully paved since approximately the 1950s.

In 2004, the 8801 property was sold to Merrill Creek Holdings, LLC (MCH). MCH sold the 8801 property to CenterPoint in 2014. IAAI has been a tenant on the property since the sale in 2004.

2.4 Geology and Hydrogeology

This section summarizes the local geology, the inferred hydrogeology, and the tidal influence on the 8801 property.

2.4.1 Site Geology

Soil in the Lower Duwamish River valley typically consists of low- to moderate-permeability shallow alluvial deposits composed of stratified silt, clay, silty sand, sand, and occasional layers of peat. The alluvial deposits have been sourced from eroded soil and volcanic debris from Mount Rainier and have been deposited in association with organic material in the river system. The LDW channel has been modified by human activity, which introduced large amounts of sand, silt, and gravel related to channel alterations.

Previous investigations by other parties at the 8801 property documented interbedded silt, sand layers, and lenses consistent with regional geology and deposits in a meandering river valley. Fill material underlies paved surfaces and is up to 10 feet thick in some locations. Fill materials include gravelly structural fill beneath buildings and paved areas, poorly graded sand to silty sand fill deposits, and gravelly backfill materials in excavations.

Fill material at the 8801 property is underlain by a layer of fine-grained material, including silt, sandy silt, and silty sand that extends to a depth of 5 to 15 feet bgs. This fine-grained material layer appears to be laterally continuous in the western portion of the 8801 property but contains lenses of silty sand in the central and eastern portions. A poorly graded sand layer, which typically contains less than 10% silt, is generally present beneath the fine-grained layer beginning at 10 to 15 feet bgs, although at some locations it is present immediately beneath the pavement surface or the fill material. This layer locally contains thin lenses of silty sand or silt. A layer of fine-grained materials, consisting mainly of silt and silty sand, is typically present beneath the poorly graded sandy layer at depths of approximately 30 to 50 feet bgs. This fine-grained silty material acts as a confining layer to groundwater flow on the western part of the site. No deeper wells have been installed on the eastern part of the 8801 property to determine if the confining layer is continuous. The lower fine-grained layer is typically underlain by poorly graded sand to the maximum depth explored at the 8801 property (60 feet bgs).

2.4.2 Site Hydrogeology

Three groundwater zones (Zones A, B, and C) have been monitored at the 8801 property. Zone A comprises the uppermost portion of the upper aquifer, and wells were screened to include the free water surface (typically 8 to 10 feet bgs) within layers of silty sand, sandy silt, and poorly graded silty sand. Zone B comprises the lower portion of the upper aquifer (typically 25 to 35 feet bgs) and monitoring wells have been screened above the silty confining layer present in the western portion of the 8801 property. The upper unconfined aquifer consisting of Zone A and Zone B are approximately 35 to 40 feet thick from the top of saturated soil. Zone C comprises the lower aquifer, a deeper groundwater zone beneath the silty confining layer at approximately 45 to 55 feet bgs. The base of the deeper aquifer at the 8801 property is unknown; however, the thickness is a minimum of 20 feet. Monitoring wells MW-#A are screened within the Zone A aquifer, monitoring wells MW-#B are screened within the Zone B aquifer, and monitoring wells MW-#C are screened within the Zone C aquifer.

Results of groundwater monitoring at the 8801 property indicate that the hydraulic gradient in the shallow aquifer (Zones A and B) is generally toward the west and has been calculated to be 0.0017 during low tide (GeoEngineers, Inc. and Kennedy/Jenks/Chilton, 1990). Kennedy/Jenks Consultants (Kennedy/Jenks) calculated the hydraulic conductivity in 1998 in the shallow aquifer using slug test data for the 8801 property. The results were around 0.01 foot per minute, although tidal fluctuation would significantly reduce the flow rate of groundwater across the 8801 property (Kennedy/Jenks, 1998). Groundwater in Zone C is assumed to flow west toward the LDW, although insufficient data are available to calculate a hydraulic gradient in Zone C.

Groundwater elevation data from the 8801 property collected at or near low tide in 2002 and 2006 indicate downward vertical gradient from Zone A to Zone B, and an upward gradient from Zone C to Zones A and B along the western boundary of the 8801 property.

The hydraulic gradient at the western edge of the 8801 property is influenced by a sheet pile wall bulkhead that extends along approximately the northern two-thirds of the western edge of the 8801 property to a depth of approximately 30 feet bgs (-22 feet mean lower low water). Water table elevation contours drawn from previous monitoring events and the 2011 data gaps investigation (Figure 4) show a general westward flow of groundwater across the 8801 property, with localized flow to the southwest in locations close to the LDW. Groundwater upgradient of the sheet pile wall moves westward and is inferred to flow under the wall before moving upward and discharging to the LDW. The groundwater flow under the wall is inferred since little to no leakage through the sheet pile wall has been observed during low tide and contaminant distribution is consistent with a westerly

groundwater flow. Groundwater also flows around the southern end of the sheet pile wall and discharges along a seepage face at low tide.

The water in the aquifers is anaerobic due to the use of oxygen by decaying of natural organic material. The naturally anaerobic groundwater conditions result in leaching of naturally occurring metals such as iron and manganese from the soil.

2.4.3 Tidal Influence

Tidal elevation data from the Zone A aquifer collected over ten groundwater sampling events conducted between April 1997 and August 2006 were used to predict the full range of tidal activity at the 8801 property from high-high to low-low tides. Data from the sampling events were compared to National Oceanic and Atmospheric Administration (NOAA) tidal data and corrected for the tidal and elevation differences between the NOAA station and the 8801 property. The tidal events were then plotted and used to determine tidal influence at the 8801 property (Anchor Environmental, LLC [Anchor], 2008a).

Results of the analysis indicate that the maximum tidal fluctuation at the LDW 8801 site boundary ranges from -3.03 feet relative to MSL to +1.85 feet MSL in the southern portion of the 8801 property, where riprap demarcates the 8801 property boundary. Farther north, where the sheet piling bulkhead demarcates the 8801 property boundary, the maximum tidal fluctuation ranges between -1.80 feet MSL and +1.32 feet MSL. The North American Vertical Datum of 1988 (the upland elevation unit of measurement) is approximately 4.27 feet greater than MSL.

2.5 Previous Investigation and Remedial Activities

This section briefly describes the investigations and remedial actions that have been undertaken from 1986 to date at the 8801 property and some of the work undertaken on the adjacent properties. Investigation and remedial activities between 1986 and 2009 are described in greater detail in the RI Report (Amec, 2011).

2.5.1 Investigations – 1986 to 2009

Investigation commenced in 1986 with an assessment on the condition of 19 underground storage tanks (USTs) on the 8801 property. After assessment was complete, 11 USTs were removed, 1 was decommissioned in place, and 1 was replaced. Investigation around the USTs identified VOCs in groundwater in the north fire aisle where four USTs used to store solvents were located, and hydrocarbons in soil and groundwater along the south fire aisle where oils and diesel hydrocarbons used to fill trucks were stored. The primary solvent in use at the facility was 1,1,1-tetrachloroethane.

Over the next nine years, much of the investigation focused on delineating the VOC plume and assessing the effectiveness of pump-and-treat remedial activities associated with the VOC groundwater plume. Other investigations at that time included collecting soil samples in the southern portion of the 8801 property to determine if Monsanto's past actions of placing fill on the 8801 property had impacted soil, and investigation and removal of a hydraulic oil spill on the western side of the 8801 property.

In 2002 and 2004, two sitewide investigations were undertaken that included collection of soil, groundwater, stormwater water and solids, and seep samples. During both investigations, focused sampling was undertaken in areas where past activities or investigations indicated contaminants may be present. The 2004 investigation included collecting samples in a grid spaced approximately 100 feet apart across the whole property. The focused areas included the paint mixing area to the east of the main warehouse, the steam wash pit area just west of the water tower, the southwest storage area in the southwest corner of the property, the southern end of the Off-Highway Building (east of the fiberglass building), and along the southern fire aisle where the hydrocarbon USTs had been located.

Site-wide groundwater sampling events were undertaken in the spring and fall of 2006. Chemical analysis included VOCs, metals, total PCBs, polycyclic aromatic hydrocarbons (PAHs), semi-volatile organic compounds (SVOCs), and TPH. In addition to collecting groundwater samples from wells on the property, samples were also collected for metals analysis from two wells (I-205, and I-206) on the adjacent Boeing property to the north. High levels of arsenic in groundwater were detected in the groundwater on the Boeing property but not in wells on the 8801 property.

Investigation of sediments adjacent to the 8801 property has been undertaken as part of the LDW-wide RI work. Under the requirements of the sediment AO, the sediments immediately adjacent to the 8801 property were investigated in 2006 and 2008. The samples were collected at 22 stations in proximity to the 8801 property at approximate depths ranging from 0 to 10 centimeters. Sediment samples were analyzed for metals (arsenic, cadmium, chromium, copper, lead, mercury, silver, and zinc); PCBs; low-molecular-weight PAHs; high-molecular-weight PAHs; chlorinated hydrocarbons; phthalates; hexachlorobutadiene; *N*-nitrosodiphenylamine; phenols; benzyl alcohol; benzoic acid; SVOCs; and dioxins/furans. Further sampling was undertaken in February 2008 to reassess specific surface locations and collect core samples of the deeper sediment at four locations. The core samples were collected in the LDW near the three outfalls and the northern property boundary. Surface samples were collected adjacent to the northern property boundary. These samples were analyzed for the sediment management standards suite of compounds. The results of both investigations are presented in a report generated by

Anchor QEA, LLC in 2009 (Anchor, 2008b). The sediment samples contained PCBs above the EPA LDW ROD remediation action levels.

2.5.2 Investigations – After 2009

In 2009, IAAI was requested by Ecology to sample the solids within the stormwater system on the 8801 property. Windward Environmental LLC (Windward) prepared a sampling and analysis plan (SAP) that was approved by Ecology. The work included collecting samples of solids from catch basin inserts, catch basins, and the stormwater treatment system on a quarterly basis for a period of one year between 2009 and 2010. Windward subdivided the 8801 property into areas and collected composite samples within those areas. The report concluded that the solids identified in the stormwater system at the 8801 property are similar to those identified on other sites along the LDW (Windward, 2011).

In 2011, Amec undertook a feasibility data gaps investigation. Ecology approved the SAP in advance of the investigation work. The objective of the investigation was to delineate areas of concern and collect information to inform the remedial alternative selection. The investigation included 12 soil borings (DG11-1 to DG11-12) for the collection of soil samples; installation of 11 monitoring wells (MW-43A, MW-44A, MW-45A, MW-46A, MW-47A, MW-48A, MW-49A, MW-40B, MW-47B, MW-48B, and MW-49B) for the collection of soil and groundwater samples; and the collection of building and infrastructure surface materials for analysis. The data was summarized in the FFS report (Amec, 2013).

In 2011 through 2012, monitoring wells located on the adjacent Boeing property to the north were sampled and analyzed by Boeing's consultant. During four sampling events, monitoring well IT-MW-6 on the adjacent property contained TCE and vinyl chloride above the CULs at that time. Monitoring well IT-MW-7 also contained TCE above the CUL at that time during the first sampling event but not on subsequent occasions (Shannon & Wilson, 2019).

In October 2014, Leidos, Inc. (Leidos) on behalf of Ecology inspected various stormwater vaults and collected two stormwater samples on the 8801 property. Stormwater samples were collected from catch basin N(60) located in the northwest corner of the property and from the pre-treatment vault associated with the treatment system at the Southern Outfall on the property. The samples were analyzed for LDW parameters including dioxin/furans and PCBs as aroclors and congeners.

In March and April 2017, Leidos collected groundwater and surface water samples from 17 properties located immediately adjacent and regionally upgradient from the LDW. At the 8801 property, monitoring wells MW-16A, MW-30A, and MW-42A were sampled and analyzed for PCBs as congeners and as aroclors. In advance of the groundwater sampling

by Leidos on the 8801 property, the three monitoring wells were inspected and polyethylene tubing found at the base of MW-16A was removed on March 16, 2017. According to the data report summarizing the results (Leidos, 2017), the samples collected at the 8801 property contained total PCB congeners at concentrations ranging from 0.00299 J (J means an estimated concentration) micrograms per liter ($\mu\text{g/L}$) to 0.0352 J $\mu\text{g/L}$. PCB aroclors were not detected within two samples and were detected in one sample. MW-16A had PCB detections both as congeners and aroclors. The groundwater sample from MW-16A was also analyzed as an unfiltered and filtered sample. The filtered sample also contained PCBs as congeners and aroclors. The polyethylene tubing may have contributed to the congener concentration identified in MW-16A, since polyethylene tubing has been analyzed and found to contain detectable congeners (Leidos, 2016).

Groundwater sampling was undertaken in February 2019. Ecology approved the work plan in advance of the sampling. The objective of the sampling was to collect current halogenated VOC data to inform the remedial design approach and to obtain baseline data from monitoring wells downgradient of the proposed area of development. Groundwater samples for analysis were collected from 36 wells on the 8801 site (MW-1A, MW-6A(R), MW-7A, MW-9A, MW-12A, MW-14A, MW-15A, MW-16A, MW-18A, MW-22A, MW-23A, MW-24A, MW-25A, MW-26A, MW-27A, MW-28A, MW-28B, MW-29A, MW-30A, MW-31A, MW-32A, MW-33A, MW-34A, MW-35A, MW-36A, MW-37A, MW-40A, MW-40B, MW-41A, MW-42A, MW-43A, MW-44A, MW-45A, MW-46A, MW-47A, and MW-48A) and 2 wells on the adjacent Boeing property (IT-MW-6 and IT-MW-7). Groundwater from most of the 8801 property wells were analyzed for halogenated VOCs, carcinogenic PAHs, bis(2-ethylhexyl)phthalate, and total and dissolved arsenic and copper. A subset was analyzed for gasoline and diesel range hydrocarbons and monitored natural attenuation parameters. Five nearshore wells (MW-30A, MW-35A, MW-36A, MW-37A, and MW-44A) were also analyzed for PCBs by aroclor and congener. The Boeing wells were only sampled for halogenated VOCs. Results are summarized in the FS Report (Shannon & Wilson, 2019).

2.5.3 Past Remedial Activities

Remedial activities have been undertaken on the 8801 property since 1986. Major remedial activities have included removal of USTs, installation of a groundwater pumping and treatment system, excavation and disposal of contaminated soil, application of oxygen-releasing compounds (ORC™) to the subsurface soil, storm drain inspection and cleaning, installation of an AS/SVE system, installation of two stormwater treatment systems, and slip lining parts of the stormwater system pipes. The location of the excavations is shown in Figure 5. The activities in date order are described below:

- Removal of 11 USTs in 1986. One UST that stored acetone was decommissioned in place at that time.

- Extraction of groundwater from the north fire aisle from 1993 until well failure due to brackish water in 1995.
- Excavation and off-site disposal of 80 cubic yards of soil impacted with hydraulic oil from the north end of the southwest storage area in 1995.
- Removal of a diesel UST located in the south fire aisle due to a diesel release. The UST was removed, 200 feet of the storm drain replaced, and approximately 200 cubic yards of impacted soil were excavated and disposed of offsite in 2000.
- Removal of two USTs containing oil and antifreeze along the south fire aisle. Approximately 120 cubic yards of petroleum-impacted soil were excavated and disposed of offsite in 2001.
- Completion of video camera surveys of the stormwater drain system in 2001 to 2003.
- Removal of two diesel and oil USTs from the south fire aisle and excavation and off-site disposal of approximately 735 tons of petroleum-impacted soil in 2003. ORC was placed in the excavation prior to backfill.
- Removal of the previously (1986) closed-in-place acetone UST from the northwest area in 2003.
- Installation of an AS/SVE system in the western portion of the 8801 property. Installation of the AS/SVE system, including excavation and off-site disposal of approximately 1,100 tons of soil in 2004.
- Excavation of approximately 1,470 tons of petroleum-impacted soil near the eastern end of the south fire aisle in 2004.
- Excavation of 140 tons of petroleum-impacted soil west of the main warehouse building (at the H4 location on the grid sampling points) in 2004.
- Placement of ORC™ on the western end of the south fire aisle corridor in 2004.
- Comprehensive cleanout of the on-site storm drain system, storm drain lines, and catch basins by flushing solids from the line, off-site disposal of collected solids and wash water, and capping and closure of the middle outfall in 2004. A catch basin located 100 feet east of the middle outfall and associated piping were filled with controlled density fill in 2006.
- Repair of a break in the stormwater pipe in 2006 (west of the oil/water interceptor in the northwest corner of the property) by injection of a sealant and lining of the pipe with a resin-impregnated felt.
- IAAI installed two vaults to treat stormwater – one east of the North Outfall and one east of the Central Outfall (formerly known as the South Outfall) in 2007. The work adjacent to the Central Outfall also included some regrading to ensure sheet flow of stormwater did not drain to the LDW. The stormwater treatment system consisted of a cyclone and filter system designed to remove particulates and other contaminants to ensure that the stormwater met the National Pollution Discharge Elimination System

(NPDES) permit that IAAI has for their operations. During excavation work, sidewall and bottom soil samples were collected and analyzed.

- IAAI slip lined the main conveyance line of the northern stormwater system from the northwest corner (adjacent to the southeast of their stormwater vault) to the middle of the warehouse in 2012. The western portion of the stormwater line is submerged below the groundwater table. It is understood that the purpose of the slip lining was to reduce the contribution of zinc from the metal pipe to the stormwater. Solids that accumulated in the stormwater line were removed in advance of the work.
- IAAI's NPDES permit number WAR008681 was renewed in 2015 and is effective through 2019. The permit covers stormwater outfall from operations at the 8801 property and the adjacent property to the south (Container Properties LLC). IAAI has upgraded the stormwater system on the 8801 property based on exceedances of the copper and zinc benchmark values, changing the treatment filter material from zeolite, perlite, and granular activated carbon to Metals Rx™. Other upgrades include adding modular treatment systems to the base of downspouts from the warehouse building, more frequent cleaning of gutters on buildings, painting of flashing to contain surface materials, reducing the use of copper containing herbicide, and improving their sitewide management of materials.
- In 2007, characterization and remedial activities were undertaken in the north west corner of the Container Properties western parcel immediately south of the 8801 property. During characterization activities green soil with viscoelastic behavior (like silly putty) was noted in three borings and hydrocarbons odors were noted in other samples. Remedial activities consisted of excavation to remove copper (maximum concentration of 18,200 milligrams per kilogram [mg/kg]), and TPH (gasoline maximum concentration of 13,000 mg/kg and diesel maximum concentration of 2,100 mg/kg) contaminated soil. During excavation activities hydrocarbon odors were noted in the north wall of the excavation (the southern boundary of the 8801 property). The excavation did not extend onto the 8801 property (Geomatrix Consultants, Inc., 2007.)

3 CONCEPTUAL SITE MODEL (CSM)

This section summarizes the nature and extent of the COCs and presents the CSM.

3.1 Distribution of Contaminants of Concern (COCs)

The distribution and occurrence of the chemicals within each media is briefly discussed below. The distribution of COCs are shown in Appendix A figures. In the figures, detected concentrations and detection limits (for non-detects) for each COC are screened against the chemical's selected CUL. CUL selection is discussed in Section 4.1.

3.1.1 Petroleum Hydrocarbon-Related Compounds

In soil, samples that had been collected in 2004 or earlier and analyzed for different petroleum hydrocarbons exceeded their respective CUL. However, subsequent soil samples collected in 2011 from many of these locations demonstrated that concentrations had declined to below CULs. This is likely due to remedial activities undertaken in 2004 being effective, or natural degradation of these organic compounds. Sample/locations where it is unknown if the concentrations have declined and that are above the CUL have been addressed in the FS and this report.

One soil sample (FWW-1) containing gasoline-range hydrocarbons above the value protective of indoor air is located below the footprint of the building proposed to be constructed during property redevelopment. Other gasoline-range hydrocarbon soil samples above the CUL, but outside the footprint of the proposed new building are at boring A1 (northwest corner of the 8801 property) and near boring E7 (southern property line on the west).

Oil-range hydrocarbons have been detected above the CUL at BY-1 (former southwest storage area), E7-S2-2 (northwest corner), and FTF-2 (below warehouse building). Due to the isolated nature of FTF-2 and the fact that remedial actions were completed just south of the boring in 2004, no further action for this occurrence will be taken. This approach is supported by the fact that the groundwater downgradient of the boring is not contaminated.

Post remediation, gasoline-, and oil-range hydrocarbons have exceeded the CUL in groundwater only at A1 (an area that was not remediated), in the southwest storage area and at the south west property boundary. Groundwater collected in 2011, near boring A1 at MW-44A, did not contain gasoline-range hydrocarbons or benzene at elevated concentrations; however, a groundwater sample collected in 2019 from MW-44A did contain elevated diesel- and oil-range hydrocarbons.

Carcinogenic polycyclic aromatic hydrocarbons (cPAHs) in soil measured as total cPAH toxicity equivalent quotient (TEQ) are found in locations where diesel- and/or oil-range hydrocarbon concentrations have been identified and concentrations have declined post remedial activities. The remaining total cPAH TEQ above the CUL have been detected in soil samples from near A1, E7, the former southwest storage area, and in two sidewall samples of a former excavation at boring H4.

In groundwater, total cPAH TEQ detected above the CUL during the 2019 groundwater sampling event was identified in wells MW-7A (northwest corner), MW-15A and MW-18A (northwest of the warehouse building), and MW-30A and MW-37A (former southwest storage area). The 2019 detected concentrations are a consequence of the laboratory being

able to detect lower concentrations and the groundwater results were generally low and within two times the PCUL.

Sediment samples that were collected adjacent to the 8801 property before and after the stormwater treatment system was installed did not exceed the LDW sediment quality standard levels for individual cPAHs. (There is not a cPAH TEQ value for sediments.)

3.1.2 Metals

In soil, arsenic, copper, and lead are COCs. All three metals are found in the southwest storage area, and lead predominates as the soil COC in that location. Copper in high concentrations in soil has been identified near E7, and a single sample of elevated arsenic in soil lies to the west of the administration building. The southwest storage area lies close to the LDW and is an area where the shoreline is protected by a berm and riprap armor. Cadmium and chromium in one sample (BY-1) in the southwest storage area exceeds the value protective of the sediments by bank erosion. Consequently, cadmium and chromium are a COC for that one location. Hexavalent chromium in soil above the CUL has been detected at two locations at the former wash pit. Since groundwater has not been analyzed for hexavalent chromium it is unknown if the soil is leaching to groundwater. A sample will be collected for hexavalent chromium analysis from a monitoring well immediately adjacent to and downgradient of the soil samples during the next sampling round in 2019 to determine if this metal is a COC for the former wash pit area.

Only arsenic and copper have been detected above the CULs in groundwater, and copper is more commonly above the level than arsenic. In 2019, only one location contained arsenic in groundwater above the CUL. The CUL exceedances appear to correlate with the location of the halogenated VOC plume and former hydrocarbon impacted areas; the distribution suggests that the presence of these metals in groundwater is the result of mobilization caused by reduced pH resulting from the degradation of halogenated VOCs and hydrocarbons.

Arsenic, copper, and lead have been detected in building materials, including paint, glazing, and brick on the main warehouse building. Testing of the sediments adjacent to the 8801 property demonstrated that they are not contaminated by these metals. Therefore, the buildings materials appear not to be migrating to the LDW at concentrations that are detrimental to the sediments.

3.1.3 Halogenated Volatile Organic Compounds (VOCs)

Halogenated VOCs that are COCs are tetrachloroethene (PCE), TCE, and vinyl chloride. 1,1-dichloroethane (1,1-DCA) also was identified in groundwater at one location above the CUL that is protective of indoor air.

PCE, TCE, and vinyl chloride in soil exceed the CULs in multiple locations and are more widespread along the northwestern portion of the 8801 property, the northwest corner, south of the former fiberglass shop, and in the southwest storage area. Vinyl chloride shows up less frequently in saturated soil.

In groundwater, vinyl chloride is the halogenated VOC that occurs most frequently. The halogenated VOCs in groundwater are found in the north fire aisle, extending westward along the northern property line and southwestward toward the western property boundary. These halogenated VOCs have not been detected above CULs in the B or C wells indicating that they are not migrating downwards. TCE has been detected to the north of the property boundary line on the adjacent property in wells IT-MW-6 (immediately north of the north fire aisle property line) and IT-MW-7 (north of the northwestern corner property line). Vinyl chloride has also been detected within well IT-MW-6.

TCE, vinyl chloride, and 1,1-DCA in groundwater exceed the CULs protective of indoor air either under or near the western footprint of the building proposed to be constructed during redevelopment.

3.1.4 Polychlorinated Biphenyls (PCBs) and Dioxins/Furans

The CUL for total PCB aroclors is the practical quantitation limit (PQL). Because of this, any detection of PCBs is an exceedance of the CUL.

Most PCB aroclor detections are in the near surface unsaturated soil. Locations where these detections occurred are in the former southwest storage area, in the area around former boring E7, in sidewall samples from the excavation at H4, and to the north of the former fiberglass shop and warehouse building. In saturated soil, PCB aroclors are identified in similar locations as within unsaturated soil with the addition of the area beneath the southern end of the former Off-Highway Building. Total dioxin/furan TEQ has been detected above the cleanup within soil samples taken from boring C6 and DG11-1, located within the southwest storage area of the 8801 property where PCBs have also been detected.

PCB aroclors in groundwater consistently have been detected at MW-16A located on the northern property line on the eastern side of the 8801 property. At MW-34A, the well immediately west of MW-16A, a detectable concentration of PCB aroclors was also reported

in 2002. Wells farther west of these two wells on the northern end of the 8801 property and along the LDW have not identified any concentrations of PCBs aroclors. The only exception is MW-30A, adjacent to the LDW on the southern end of the 8801 property. At MW-30A, detectable concentration of PCB aroclors have been identified on two occasions.

PCBs have been detected in infrastructure material, including joint compound between concrete slabs, paint, glazing, and bricks around and on the main warehouse. The presence of PCB aroclors in groundwater at MW-16A and MW-34A (both wells are adjacent to the northern end of the warehouse building) is likely related to the PCBs in concrete joint compound found in close proximity to the warehouse and the monitoring wells. Sediment samples collected adjacent to the 8801 property exceed the LDW remediation levels for PCBs in a number of locations.

3.1.5 Bis(2-ethylhexyl)phthalate

Bis(2-ethylhexyl)phthalate has been detected above CUL in soil samples taken from the saturated zone primarily within the former southwest storage area, in the northwest corner of the property near boring A1, and northwest of the warehouse building. In groundwater samples collected from across the 8801 property, bis(2-ethylhexyl)phthalate has been detected above the CUL although the quantity of exceedances has declined as sampling techniques have improved (meaning less cross contamination from sampling material).

Within sediment samples collected adjacent to the 8801 property before and after the stormwater treatment system was installed, bis(2-ethylhexyl)phthalate concentrations did not exceed the sediment quality standards.

3.2 Conceptual Site Model (CSM)

This section discusses the potential sources of contaminants to media, the potential receptors, and the transport pathways. A flow chart and illustration of the CSM for the 8801 property are presented in Figure 6.

3.3 Contaminant Sources

The potential sources of contaminants to soil and groundwater are (a) leaks from the former USTs located in the north and south fire aisles and leaks from equipment within buildings, such as in the Off-Highway Building as well as isolated spills; (b) off-site sources of arsenic from Boeing (via groundwater flow); (c) fill material placed in the northern end of the southwest storage area by Kenworth and on the southern property by Monsanto; and (d) surface activities, including the storage of cars that have been in automobile accidents.

The potential source of contamination to air is vapor generated from soil and groundwater contaminated with halogenated VOCs and gasoline. The potential source of contamination to surface water is groundwater contaminated with halogenated VOCs. Although near shore soil contamination is present, bank erosion is not anticipated at the 8801 property; much of the shoreline is protected by a sheet pile wall, and the remaining shoreline is protected by a 12-foot-wide berm of quarried material which is armored on the LDW side.

Other potential sources of contaminants to sediments are stormwater solids sourced from infrastructure materials, the former surface activities that included the storage of cars that had been in automobile accidents, and airborne particulates that settle out of the atmosphere. Much of the stormwater borne materials are removed by on-site stormwater treatment systems and the system discharge is managed under the NPDES permit.

3.3.1 Potential Receptors

Currently, the 8801 property is vacant and all parts of the 8801 property are either paved with asphalt or concrete or are covered with buildings that have interior floor slabs. As previously discussed, the current owner proposes to redevelop the 8801 property with a single large warehouse structure which will be raised approximately 4 feet above the existing grade using imported fill (Figure 3). The proposed development will include new paving throughout the property and the removal of all existing buildings except for the former fiberglass shop which will remain. The proposed redevelopment will mean that the 8801 property surface will continue to be covered for many decades.

Despite being vacant, the 8801 property is currently accessible to employees of IAAI (occupational workers) and visitors. Current and future occupational workers, and visitors are not and will not be exposed to soil or groundwater because it is beneath the paved surface. The groundwater on the 8801 property is non-potable (Shannon & Wilson, 2019), as is the water in the LDW, and there are no known water extraction points for either at the 8801 property. Therefore, occupational workers on the 8801 property are not exposed to groundwater or surface water related to extraction activities.

Current occupational workers and visitors at the 8801 property could potentially be exposed to infrastructure material on or adjacent to the warehouse and powerhouse (joint compound between concrete slabs, paint, glazing, bricks, etc.). This exposure pathway is limited, as most occupational workers do not physically contact these materials in the normal course of their work. Future occupational workers will not be exposed to the infrastructure material because the warehouse, surrounding buildings and surfacing with the contaminated materials will be removed during preparation for the redevelopment.

Current occupational workers (when on the 8801 property) could potentially be exposed to vapors from the halogenated VOC groundwater plume on the western side of the 8801 property. The risk is considered low because (a) the majority of the area overlying the plume is open to the air with the exception of an empty structure (the former fiberglass shop), which has permanently open bay doors and large holes in the building side and roof so vapors would not accumulate; (b) occupational workers are rarely on site and do not spend a large amount of time on the western part of the 8801 property; and (c) the vapor concentrations from the halogenated VOC groundwater plume are relatively low (although not all areas are below the CULs). Future users could be exposed to vapors from the halogenated VOC plume on the western side of the 8801 property; however, the 4 feet of fill material that will be placed beneath the footprint of the proposed new building will act as further separation from the plume. The former fiberglass building, which will not be demolished, is not currently occupied and there is no future plan to occupy the building.

Construction workers will be exposed to soil and potentially groundwater on the 8801 property through direct contact or inhalation during redevelopment activities. Construction workers also may be exposed to vapors within subsurface structures such as the stormwater treatment system. Soil, groundwater, and air exposure to construction workers is a complete pathway.

Because the 8801 property is covered entirely with buildings and pavement and will continue to be covered in the future, the conditions on the 8801 property meet the requirement for ending the terrestrial exposure evaluation (Shannon & Wilson, 2019). Although COCs are present at the 8801 property, the building/pavement cover prevents exposure of terrestrial ecological receptors to the soil or groundwater.

Surface water impacted by contaminated groundwater are considered a complete pathway to off-property ecological receptors (benthic and aquatic species) via direct contact and ingestion, and to off-property human receptors via ingestion and direct contact with the surface water and via ingestion of the benthic and aquatic species that live in the LDW.

Sediments impacted by contaminated groundwater are also considered a complete pathway to off-property ecological receptors (benthic and aquatic species) via direct contact and ingestion, and to off-property human receptors via ingestion and direct contact with the sediments and via ingestion of benthic and aquatic species that live in the LDW.

3.3.2 Transport Mechanisms

Soil and groundwater are not exposed on the surface of the 8801 property. Contaminants in soil can leach to the groundwater and the groundwater to the surface water. The pavement throughout the 8801 property is old; however, it is patched on approximately a yearly basis,

and although some stormwater likely infiltrates through cracks, the quantity is likely to be limited.

The contamination on the 8801 property was present prior to 1986; therefore, chemicals in the saturated soil are likely in equilibrium with the groundwater. This is supported by the data, since many chemicals have been identified above the soil CUL that have been established based on partition of the chemicals out of soil into groundwater, and yet those chemicals are below the CULs in groundwater. The proposed future use for the property includes surface cover throughout, meaning that the groundwater will not be more vulnerable after future redevelopment. In addition, there will only be minimal disturbance of the surface during redevelopment because fill is being placed on top of the existing surface instead of excavating below the existing grade like many other developments.

Soil and groundwater can also enter the stormwater system. However, the portion of the stormwater system that is submerged below the water table was slip lined in 2012, and it is unlikely that groundwater is now entering the stormwater system. Particles of soil could be entering the stormwater system through cracks in the pipe. This contribution is likely to be low since most of the system does not intersect with areas of contamination and a treatment system would remove them prior to discharge.

Solid materials from the surface activities, degraded infrastructure, and deposition of atmospheric particles will be transported through the stormwater system. Since 2007, stormwater treatment systems have been present on the 8801 property and surface sweeping is undertaken to remove surface materials before they enter the stormwater system. These actions have likely reduced but not eliminated this pathway. Removal of the buildings during future redevelopment will likely result in a new stormwater infrastructure system with new catch basins that will have more integrity, which will prevent the potential entry of soil particulates.

4 CLEANUP STANDARD

This section discusses the CULs that are protective of human health and the environment, the remediation levels used for soil and halogenated VOCs in groundwater, and the points of compliance (POCs) where those CULs apply.

4.1 Cleanup Levels (CULs)

The CULs for soil, groundwater, and air at the 8801 property are based on unrestricted land use and are shown in Table 1.

The starting point for establishing the CULs were the Ecology PCULs, which are based on various exposure pathways, including soil partitioning to groundwater and entering surface water, and are protective of sediment, surface water, and consumption of fish. The proposed CULs are based on applicable state and federal applicable or relevant and appropriate requirements. The values were then adjusted for PQLs achievable by analytical laboratories and for natural background concentrations of COCs, as appropriate.

4.1.1 Soil

For COCs in soil the cleanup values are primarily the partition number, background, PQLs or the MTCA Method B value for human health direct contact as discussed by chemical below.

TCE, PCE, and vinyl chloride are currently partitioning from soil as concentrations in groundwater that exceed the CUL. Therefore, the CULs selected for these three COCs are based on a value that is protective of partition to surface water via groundwater based on non-potable groundwater in either the saturated or unsaturated soil as appropriate. The CULs for TCE and vinyl chloride in soil are corrected to the PQLs achievable by analytical laboratories.

Soil CULs for bis(2-ethylhexyl)phthalate, cPAHs, PCBs and hexavalent chromium are also based on partition numbers. The CULs for bis(2-ethylhexyl)phthalate, cPAHs, and PCBs in soil are corrected to the PQLs achievable by analytical laboratories.

However, these soil concentrations are so low that assessment of achieving the cleanup standard for TCE, PCE, vinyl chloride, bis(2-ethylhexyl)phthalate, cPAHs, PCBs, and hexavalent chromium will be based on groundwater concentrations (i.e., demonstrating that groundwater CULs are achieved and maintained as proof that the soil is no longer contributing to the groundwater at a level to cause exceedance of the CUL).

Arsenic, copper, and dioxin/furan TEQ soil CULs are based on background concentrations. Cadmium and chromium soil CULs are based on protection of bank erosion and relate only to the southwest storage area as they are below the more stringent PCULs elsewhere on the 8801 property.

Lead is not present in groundwater above the CUL; therefore, the soil CUL is based on MTCA Method B for direct contact. Gasoline- and oil-range hydrocarbons are present in groundwater in only one location. Therefore, the gasoline-range hydrocarbons soil CUL is based on protection for indoor air where the proposed building overlies a sample with an exceedance. MTCA Method A residual concentration CUL is used for oil-range hydrocarbons.

The additive hazards or risks for the proposed soil CULs was not completed because the selected values are based on applicable or relevant and appropriate requirements, PQLs, or Method B direct contact values.

4.1.2 Soil Remediation Levels

Soil remediation levels for the COCs are discussed in this section. Due to the stringent values required to ensure that soil is protective of the leaching pathway, remediation levels are proposed to be used to delineate excavation areas. The areas proposed to be excavated are either where multiple COCs are co-located (excavation will reduce the overall mass of COCs on the property) or where the quantity of a COC known to be leaching into groundwater could be reduced (for example, in an area where TCE concentrations are elevated).

The soil remediation levels have been developed in accordance with WAC 173-340-355 and take into consideration the expectations for cleanup alternatives in WAC-340-370. The soil remediation levels that have been selected will ensure that the areas that have significant mass of COCs will be removed. The soil remediation levels are shown in Table 2.

The soil remediation levels have been developed in accordance with WAC 173-340-355 and take into consideration the expectations for cleanup alternatives in WAC-173-340-370. The soil remediation levels that have been selected will ensure that the areas that have significant mass of COCs will be removed. A disproportionate cost (DCA) assessment was undertaken to aid in the selection of the remediation levels. The remediation levels selection for the most persistent or most prevalent COCs on the 8801 property are discussed below.

The selected remediation level for total PCB aroclors is 0.5 mg/kg. Using a remediation level of 0.5 mg/kg to guide excavation limits will result in a mass reduction of known total PCB aroclor concentrations in soil on the 8801 property of approximately 66%.

The selected remediation level for total cPAHs TEQ is 0.6 mg/kg. Using a remediation level of 0.6 mg/kg to guide excavation limits will result in a mass reduction of known total cPAH TEQ concentrations in soil on the 8801 property of approximately 63%.

The remediation level proposed for arsenic in soil is 14.6 mg/kg because removal of soil concentrations above this level will meet the requirements of WAC 173-340-740(7)(e)(i) and (ii). This requirement is for soil not to exceed twice the CUL and 14.6 mg/kg is twice the CUL of 7.3 mg/kg. Removal of arsenic above 14.6 mg/kg will result in a mass removal of arsenic of 65%.

The selected remediation level for copper is 250 mg/kg. Using a remediation level of 250 mg/kg to guide excavation limits will result in a mass reduction of known copper concentrations above the background level in soil on the 8801 property of approximately 91%.

The selected remediation level for TCE is 5 mg/kg. Using a remediation level of 5 mg/kg to guide excavation limits will result in a mass reduction of known TCE concentrations in soil on the 8801 property of approximately 81%.

Although the remedial action selection is discussed in Section 5.3 later in the text, excavations to remove one chemical will also result in additional COCs being removed because many of them are in the same location. Consequently, the remedy will result in removal of more COC mass than when the calculation for mass removal is considered for just a single COC. The total mass that would be removed during the selected remedial activities for each COC was summed based on the excavation to remove the co-located COCs. In total, excavation to the remediation level cumulatively removes from the 8801 property soil approximately 92% of the COC mass as shown in Table 3.

4.1.3 Groundwater

In groundwater, the CULs are discussed by chemical, including the cPAHs, PCBs, copper, arsenic, and halogenated VOCs. Remediation levels are proposed for the halogenated VOCs as shown in Table 4.

Total cPAHs TEQ and total PCB aroclors. The CULs for total cPAHs TEQ and total PCB aroclors in groundwater are extremely stringent (parts per trillion) that are not currently achievable by laboratories. For this reason, the CUL for both chemicals is based on the PQL. The restoration timeline associated with achieving the CULs for these COCs in groundwater is in the order of decades even with remedial action.

Copper and Arsenic. Copper present in soil is likely being mobilized by the anaerobic conditions generated by the dechlorination of the halogenated VOCs and hydrocarbon breakdown. As the dechlorination decreases, the groundwater condition will stabilize, and copper and arsenic will re-precipitate out of groundwater as demonstrated by the 2019 groundwater sampling event results. The cleanup values for copper and arsenic in groundwater are based on a local background concentration of 8 µg/L for both chemicals.

4.1.4 Halogenated Volatile Organic Compounds (VOCs)

Calculations undertaken using the BIOCHLOR model as discussed in the FS (Shannon & Wilson, 2019) demonstrate that halogenated VOCs are naturally degrading. Remediation

levels for the halogenated VOCs are being used to achieve groundwater values inland of the property boundary with the LDW. Once remediation levels are achieved, the halogenated VOCs will naturally break down further such that they will be protective of surface water by the time the groundwater discharges into the LDW.

Halogenated VOCs generate vapor that could impact occupational occupants of future buildings. Therefore, the remediation levels of halogenated VOCs in groundwater may not be sufficiently protective of the air pathway. To determine if the groundwater remediation levels were sufficiently low to protect occupational workers, the Johnson and Ettinger Model (EPA, 2017) was used to assess occupational worker exposure. The halogenated VOCs remediation levels were entered into the model and the indoor air concentrations generated by the chemicals are less than the MTCA B values for indoor air. The cancer risk and hazard quotient of the halogenated VOCs were added together to determine the cumulative indoor air exposure risk (Appendix B). The values summed to 7.13×10^{-7} with a hazard quotient of less than 1 for protection of occupational workers. The Johnson and Ettinger model demonstrated that the remediation levels for PCE, TCE, and vinyl chloride are sufficiently protective for the air pathway.

4.1.5 Groundwater Restoration Timeline

Remediation levels are not CULs. The groundwater CULs will be achieved at the boundary of the property with the LDW within a reasonable restoration timeline. The halogenated VOC remediation levels that are protective of indoor air exposure in the western part of the 8801 property are estimated to be achieved in approximately three years (with bioaugmentation).

The restoration timeline for the remediated halogenated VOCs to meet the CULs at the point of compliance is modeled to be approximately ten years. However, the CULs for total cPAHs TEQ and total PCB aroclors in groundwater are extremely stringent (parts per trillion) and the restoration timeline associated with achieving the CULs for these COCs in groundwater is in the order of decades even with remedial action.

4.2 Point of Compliance (POC)

MTCA defines the POC as the point or points at which CULs must be attained. The POC applies to all soil, groundwater, or air at or adjacent to any location where releases of hazardous substances have occurred or that has been impacted by releases from the location. The primary affected media at the 8801 property are soil and groundwater. The inhalation pathway is also significant for the 8801 property due to the presence of halogenated VOCs in soil and groundwater.

4.2.1 Soil

POCs demonstrating compliance for pathways protective of human health, namely potential direct contact, inhalation, or ingestion of impacted soil, shall be established in the soil throughout the 8801 property from the ground surface to 15 feet bgs (WAC 173-340-740(6)(d)).

The POC demonstrating protection of groundwater shall be established in soil throughout the 8801 property (WAC 173-340-740(6)(b)).

POCs demonstrating compliance for pathways protective of human health and the environment by migration of chemicals from soil to air shall be established in the soil from the ground surface to the top of the uppermost saturated zone throughout the 8801 property (i.e., the vadose zone) (WAC 173-340-740(6)(c)).

As discussed earlier, the 8801 property is excluded from the requirement for a terrestrial ecological evaluation, because the presence of existing buildings or pavement will prevent plants and wildlife from exposure to contaminated substrate provided an institutional control is implemented in accordance with WAC 173-340-7491(1)(b).

4.2.2 Air

The POC demonstrating compliance for pathways protective of air will be ambient air throughout the 8801 property (WAC 173-340-750(6)). Per WAC 173-340-750(1)(a); the cleanup standard applies to ambient outdoor air and air within a building, manhole, utility vault, or any structure large enough for a person to fit into.

4.2.3 Groundwater

Groundwater CULs are based on indoor air protection or protection of discharge to surface water of the LDW. MTCA regulations favor permanent cleanup of groundwater contamination at the standard POC (throughout the site). A standard POC for groundwater, as described in WAC 173-340-720(8)(b), would include all groundwater in the saturated zone beneath the 8801 property and in any area affected by releases from the facility. However, under WAC 173-340-720(8)(c), Ecology may approve use of a conditional POC.

Groundwater CULs would apply at this conditional “point” of compliance and downgradient. Groundwater contamination upgradient of the conditional POC, but within the site, would not be required to meet CULs within a reasonable timeframe (as long as conditions in WAC 173-340-720(8)(c) are met).

A conditional POC for groundwater may be located either on the source property (e.g., at the property boundary) or beyond the property boundary. It is not proposed to set the conditional POC beyond the 8801-property boundary. The specific regulatory requirements for establishing a condition POC include the following:

- It is not practicable to attain the standard POC within a reasonable restoration timeframe (WAC 173-340-720(8)(c));
- The conditional POC shall be as close as practicable to the source of the release (WAC 173-340-720(8)(c)); and
- The conditional POC will not exceed the property boundary (WAC 173-340-720(8)(c)).

The regulatory requirements above must be met in order to establish a groundwater conditional POC. A conditional POC at the western property boundary was proposed in the FS due to the inability to achieve the total cPAH TEQ and PCB aroclor CULs in groundwater throughout the 8801 property within a reasonable restoration timeline (Shannon & Wilson, 2019).

4.3 Areas of Concern

Areas of concern where the COCs exceed the CULs are shown in figures in Appendix A, summarized in Table 5 and listed below.

- Soil
 - Area 1: TCE (G0)
 - Area 2: Total cPAHs TEQ (EH4-S-1.5 and EH4-W-1.5)
 - Area 3: Total PCB aroclors (DG11-11), copper (DG11-11), and gasoline-range hydrocarbons (DG11-12)
 - Area 4: Total dioxins/furans TEQ (C6 and DG11-1), total PCBs aroclors (DG11-1), and copper (SS-SW-04 and -05)
 - Area 5: Total PCB aroclors (SWS-1), total cPAHs TEQ (DS-2), oil-range hydrocarbons (former southwest storage area), arsenic (BY-3), cadmium (BY-1), copper (BY-3 and MW-43A), and lead (former southwest storage area)
 - Area 6: Arsenic (SFA-S15-3)
 - Vicinity of A1 (northwest corner): Gasoline-range hydrocarbons (see groundwater)
 - WP-4 and WP-6: Hexavalent chromium
 - SSBOT-03: Total PCB aroclors
 - B3: Lead
- Groundwater
 - Halogenated VOC Plume: PCE, TCE, and vinyl chloride

- Vicinity of A1: Gasoline-range hydrocarbons (A1), diesel- and oil-range hydrocarbons (A1 and MW-44A), and vinyl chloride
- MW-15A: 1,1-DCA
- MW-16A and MW-34A: Total PCB aroclors
- MW-30A: Total PCB aroclors
- MW-41A: Copper
- Indoor Air
 - Halogenated VOC Plume: TCE and vinyl chloride
 - MW-15A (in the center of the halogenated VOC plume): 1,1-DCA
 - Area 7: Gasoline-range hydrocarbons (FWW-1)

Of the above areas of concern, it should be noted that the total PCB aroclor contaminated soil at SSBOT-03 is located below a stormwater vault and is not accessible for remediation or likely to be an exposure route to construction worker until the system is removed (unknown date but likely decades as the vault was recently constructed in 2007). The lead sample at B3 is beneath the slab of the former fiberglass building and the AS/SVE remediation treatment system and is not accessible for remediation nor it is likely to be an exposure route to construction workers until remediation is complete and the building removed (date unknown). The hexavalent chromium areas of concern at WP-4 and WP-6 is considered contingent. Groundwater sampling is needed to determine if remediation is necessary. If groundwater sampling indicates that groundwater is not impacted, the compound will be eliminated as a COC in soil. If the groundwater contains hexavalent chromium above the CUL, the soil will be excavated and disposed offsite.

5 DESCRIPTION OF REMEDIAL ALTERNATIVES AND SELECTION

The FS (Shannon & Wilson, 2019) presents a detailed description of the actions and remediation technologies reviewed for the 8801 property COCs. The FS report incorporated review of remedial technologies limited to proven techniques applicable to the 8801 property and those acceptable to Ecology. This section summarizes the remedial alternatives that were evaluated and the alternatives selected for each media.

5.1 Remedial Action Objectives (RAOs)

The RAOs are medium-specific goals for the protection of human health and the environment. RAOs form the basis for developing and evaluating remedial actions. The RAOs are:

- Protect current and future worker exposure to soil contaminants.
- Protect workers occupying future buildings.
- Protect current and future beneficial use of surface water and sediments in the LDW by attaining groundwater CULs before groundwater migrates to the LDW.
- Achieve the groundwater remediation CULs for the halogenated VOC plume within a reasonable timeframe.

5.2 General Response Actions

General response actions are those actions that satisfy RAOs. General response actions consist of engineering, and/or institutional controls; treatment, soil excavation, and off-site disposal without treatment, monitored natural attenuation, and combinations of these. Combinations of general response actions were assembled into groups called remedial alternatives for evaluation against other remedial alternatives.

All remedial alternatives include compliance monitoring. Periodic compliance monitoring will occur until the CULs are achieved at the POCs. Selected monitoring wells will be sampled to assess the effectiveness of remedial measures undertaken to address 8801 property groundwater and to verify that soil COCs are not migrating to the LDW. The frequency of sampling will be assessed using eight quarters of groundwater monitoring undertaken after completion of the remedial actions and reduced, if warranted.

5.3 Summary of Alternatives

Remedial alternatives affecting the same areas of concern, COCs, and/or media were assigned to one of three groups: Soil, Groundwater, or the Northwest Area, where one remedial alternative was selected for each group.

- Soil – Includes all saturated and unsaturated soil on the 8801 property that is above the CULs for COCs, except for TCE and vinyl chloride since they are addressed in the groundwater remedial alternatives. Primary COCs are PCBs, cPAHs, and copper.
- Groundwater – Includes all groundwater on the 8801 property that is above the CULs for COCs and potential source material, including TCE-impacted soil and PCB-containing caulk. These remedial actions also include controls for potential affects to indoor air from the TCE groundwater plume. Primary COCs are TCE, vinyl chloride, and PCBs.
- Northwest Area – Includes soil and groundwater at the northwest corner of the 8801 property. Primary COCs are TPH and vinyl chloride.

5.3.1 Soil

Four remedial alternatives which satisfied the threshold/minimum requirements for selection are discussed in more detail below.

- **Propertywide Excavation:** Excavate and dispose offsite COCs in unsaturated and saturated soil that exceeds the CUL to a depth of 15 feet below ground surface (bgs) as shown in soil figures in Appendix A. This area covered predominately all soil in the western two-thirds of the 8801 property, along with a couple of small areas in the eastern portion.
- **Hotspot Excavation to a Remediation Level (REL) with Institutional Control:** Two alternative for hotspot excavation were considered using different RELs for PCBs and cPAHs. Both options considered six hotspot excavations, and the second option considered the removal of additional discrete locations to achieve a lower REL for PCBs and cPAHs. Both options included the excavation and disposal offsite of COCs in soil that exceed the RELs. The remaining unexcavated areas which have soil exceeding the saturated soil CULs, would be capped over the existing pavement and institutional controls would be implemented
- **Capping and Institutional Control:** Maintain the existing cap in areas where COCs in soil exceed the saturated soil CULs and provide institutional control to maintain the cap and alert workers to the presence of the COCs.

5.3.2 Groundwater

The groundwater plume COCs consist predominantly of TCE near the north property boundary and transitions to predominantly vinyl chloride downgradient to the south and west. The vinyl chloride is likely a daughter product from degradation of TCE. An AS/SVE system is active on the 8801 property and is proven to reduce concentration of volatile organic compounds in the groundwater plume. This existing AS/SVE is considered in all the remedial actions for the TCE/vinyl chloride plume.

In addition to the groundwater TCE plume, remedial actions were also developed for PCB-impacted groundwater at MW-16A and MW-34A. Remedial alternatives for the northwest area of the 8801 property (which is within the groundwater vinyl chloride plume) were considered separately in Section 5.3.3 since the area has unique challenges.

Six remedial alternatives which satisfied the four threshold/minimum requirements are discussed in more detail below. These remedial alternatives consist of combinations of remedial actions are shown in Exhibit 5-1.

Exhibit 5-1: Combinations of Actions for Groundwater Remedial Alternatives

Areas of Concern/COCs	Remedial Alternative No.			
	2a	2b	2c	2d
TCE-impacted soil	Excavate TCE to CUL	Excavate TCE to REL	Excavate TCE to REL	Excavate TCE to REL
TCE/vinyl chloride groundwater plume upgradient of existing AS/SVE system	ERD	ERD	MNA	ERD
TCE/vinyl chloride groundwater plume downgradient of existing AS/SVE system	Expand existing AS/SVE system	Expand existing AS/SVE system	Expand existing AS/SVE system	MNA
PCBs in groundwater at MW-16A and MW-34A	Remove nearby PCB-containing chalk	Remove nearby PCB-containing chalk	Remove nearby PCB-containing chalk	Remove nearby PCB-containing chalk
Potential indoor air vapor intrusion over TCE/vinyl chloride plume	Implement institutional controls	Implement institutional controls	Implement institutional controls	Implement institutional controls

NOTES:

AS/SVE = air sparge/soil vapor extraction; COCs = chemicals of concern; CUL = cleanup level; ERD = enhanced reductive dechlorination; MNA = monitored natural attenuation; PCB = polychlorinated biphenyls; REL = remediation level; TCE = trichloroethene

TCE-impacted soil removal: TCE-impacted soil on the 8801 property is contributing to the TCE/vinyl chloride plume. Two actions were considered to address TCE-impacted soil: excavation and disposal of TCE-impacted soil which is above the CUL or above the REL. For both excavation scenarios, the excavated soil would be loaded directly, if feasible, into a dump truck for transport to a permitted disposal facility. Excavated saturated soil may require stabilization or dewatering prior to loading for offsite disposal.

Enhanced Reductive Dechlorination (ERD) Plume Wide: In the area east of the existing AS/SVE system the halogenated VOCs mostly consist of TCE. A carbon source and bacteria will be injected across the halogenated VOC plume to accelerate the dechlorination of the VOCs. An estimated 157 injection wells and 3 injection events is considered in this alternative.

Monitored natural attenuation (MNA): Analytical data indicate that natural attenuation of halogenated VOCs is occurring on the 8801 property. The groundwater monitoring data over numerous years suggest that the TCE/vinyl chloride plume on the 8801 property is stable and decreasing in impact. Therefore, a program of MNA appears to be a viable remediation alternative. MNA is considered as a component to be combined with other remedial alternatives for groundwater such as excavation or excavation and injection. The BIOCHLOR modeling demonstrates that MNA could not be used as a stand-alone remedy for halogenated VOCs.

Extension of Air Sparge/Soil Vapor Extraction (AS/SVE) System: West of the existing AS/SVE system the halogenated VOCs mostly consist of vinyl chloride. Two alternatives were considered, extension of the AS/SVE system to the west or using MNA.

Removal of PCB-containing caulk: The presence of PCBs in groundwater at MW-16A and MW-34A are likely related to the PCBs in joint compound detected in concrete slab joints near the monitoring well. One viable action was identified to address PCBs at these wells which is the removal of the caulking.

Institutional control and indoor air management: Vapors from volatile COCs may adversely affect any new structures, which may be constructed over top of the TCE/vinyl chloride plume. Institutional controls are therefore required to ensure that adequate protection is in place to protect those future workers. The institutional controls provide for monitoring until groundwater remediation levels are achieved, or indoor air concentrations are demonstrated to be below the exposure thresholds. Active remedial measures are also considered to address removal of the pathway if construction is undertaken prior to levels being achieved that are below those that will impact indoor air.

5.3.3 Northwest Area

The Northwest Area was designated as a separate decision unit since the COCs vary from other areas. Impacted soil and groundwater has been detected, primarily TPH and vinyl chloride. Specifically, TPH concentrations have historically been measured at high enough levels to suggest the presence of residual free-phase hydrocarbons. Mobile, or free-phase hydrocarbons, has not, however, been encountered. Additionally, vinyl chloride has been detected in groundwater above cleanup or remediation levels. Vinyl chloride is likely a daughter product from degradation of the upgradient TCE plume as a source of vinyl chloride has not been identified in the Northwest Area.

Remedial alternatives for the Northwest Area were grouped separately from the soil and groundwater groups due to the unique challenges related to the area. These challenges include:

- **Proximity to the LDW.** There is limited travel time for COCs to achieve the CUL before discharge to the river even after remediations levels are reached. MNA is not a viable action due to the limited travel time for COCs. Furthermore, several injection remediation technologies were considered and rejected due to the potential impacts associated with the nature of the reagent (highly reactive, caustic, or pH changing) and the proximity to the LDW.
- **Presence of TPH.** Remedial technologies were considered which addressed both primary COCs for this area: TPH and vinyl chloride. ERD that is proposed for the bulk

of the TCE/vinyl chloride plume is not a viable technology for the Northwest Area because of its poor-effectiveness on TPH compounds.

- **Space constraints.** Multiple active utilities are installed in the Northwest Area, including the stormwater treatment system, oil/water separator, North Outfall and connecting underground utilities (see photograph below). These structures would remain after implementation of a remedial alternative. Expansion of the AS/SVE system and excavation of impacted soil are not viable remedial actions for the Northwest Area due to space constraints from existing installed systems.

Three remedial alternatives which satisfied the four threshold/minimum requirements are discussed in more detail below.

Pump-and-Treat: A pump-and-treat system would be installed to remove and dispose of mobile contaminants. Typically, contaminated groundwater is pumped out of extraction wells and then treated and disposed of offsite. A pump-and-treat system would require monthly maintenance and periodic replacement of components due to normal wear and tear. It is assumed that the pump and treat system would operate for 15 years.

Permeable Reactive Barrier: A permeable reactive barrier would be installed along the north boundary (with a small jog south on the western end) of the Northwest Area to allow for in situ remediation. Permeable reactive barriers allow groundwater to passively flow through the treatment zone, which contains the reactive constituents. The reactive constituents are designed to immobilize the contaminants within the barrier or transform the contaminants to less toxic compounds. This alternative assumed 15 years of operation and that replacement of the barrier was not required.

In Situ Chemical Oxidation (ISCO): ISCO would be used to reduce residual, non-mobile TPH and halogenated VOCs in the Northwest Area of the 8801 property to less than remediation levels. Various ISCO technologies were considered for injection which included hydrogen peroxide or Fenton's Reaction/Reagent, modified or non-pH-dependent Fenton's Reaction, permanganate, persulfate, and a combination of each. PeroxyChem's Klozur® CR, which is a slurry of self-activating persulfate and calcium peroxide injections at 17 locations and up to 6 events was selected for the alternative. In advance of active remediation, excavation may occur in the Northwest Area in association with this alternative. The excavation cavity would be backfilled with controlled-density fill to function as a utility-corridor barrier, reducing in situ groundwater remediation reagent infiltration into the LDW.

5.4 Evaluation of Alternatives

The selection of the alternatives meets the MTCA threshold requirements (WAC 173-340-360(2)(a)) and other MTCA requirements (WAC 173-340-360(2)(b)). The selected alternatives are shown in Figure 7.

5.4.1 Model Toxics Control Act (MTCA) Threshold Requirements

The MTCA evaluation criteria consist of MTCA minimum/threshold requirements (WAC 173-340-360(2)(a)) and other MTCA requirements (WAC 173-340-360(2)(b)).

After meeting the threshold requirements, MTCA requires that remedial alternatives be evaluated for three other requirements:

- Consider public concerns. Public concerns should be eliminated or mitigated, if possible, by selection of technologies or methods.
- Provide for a reasonable restoration time frame. The requirements and procedures for determining whether a remedial alternative provides for a reasonable restoration time frame as discussed in WAC 173-340-360(4).
- Use permanent solutions to the maximum extent practicable. To evaluate practicability, MTCA considers cost effectiveness using a DCA as specified in WAC 173-340-360(3)(e).

5.4.2 Model Toxics Control Act (MTCA) Disproportionate Cost Analysis (DCA)

The DCA uses seven criteria to compare, contrast, and rank each remedial alternative. Six of the criteria (all except cost) are used to calculate an overall weighted benefit score. An alternative's costs are considered disproportionate to benefits if the incremental costs of a more permanent alternative are greater than the incremental environmental benefits achieved by that alternative over those of lower cost alternatives (WAC 173-340-360(3)(e)(i)). This is evaluated using a Cost/Benefit Ratio, where a higher Cost/Benefit Ratio may indicate that the incremental cost is disproportionately larger than the incremental benefit.

A description of the seven criteria to compare, contrast, and rank each remedial alternative is provided below:

- **Overall protectiveness.** An alternative's ability to achieve protectiveness is a key factor. Overall protectiveness includes the degree of overall risk reduction, the time required to reduce risk and attain cleanup standards, and the improved overall quality of the environment at a site.
- **Permanence.** The long-term success of an alternative can be measured by the degree to which an alternative permanently reduces the toxicity, mobility, or volume of hazardous substances on the property. Typically, permanence considers the whole life cycle of the chemical; however, removal of the COC from the proximity to the LDW and disposal in

a managed landfill is considered to increase the permanence of the remedy for this project.

- **Effectiveness over the long-term.** An alternative's long-term effectiveness is based on the reliability of treatment technologies to meet and maintain CULs, and if using engineering or institutional controls, on their reliability to manage residual risks. Long-term reliability is also influenced by uncertainties associated with potential long-term risk management.
- **Management of short-term risks.** Short-term risk evaluates the risk posed by the cleanup action during its implementation (including construction and operation), based on potential impacts to the community, workers, and the environment, and the effectiveness and reliability of protective or mitigative measures.
- **Technical and administrative implementability.** An alternative's implementability is evaluated based on whether it is easy or difficult to implement depending on practical, technical, or legal difficulties that may be associated with construction and implementation, including schedule delays. Implementability also depends on the ability to measure the remedy's effectiveness and its consistency with MTCA and other regulatory requirements.
- **Consideration of public concerns.** Potential public concerns, whether from individuals, community groups, local governments, tribes, or federal and state agencies about a proposed cleanup alternative are addressed by means of MTCA's public involvement process during Ecology's remedy selection process.
- **Cost.** Cost considerations include design, construction, and installation costs; the net present value of long-term costs; and agency oversight costs. Long-term costs include the cost of operation and maintenance, monitoring, equipment replacement, and maintaining institutional controls.

5.5 Comparative Analysis of Alternatives

Scores of 0 to 10 are assigned to each criteria and remedial alternative. The weighted overall benefit score is calculated for each remedial alternative using weighting factors and the raw benefit score for each of the six DCA criteria (all except cost) (Exhibit 5-2). A higher weighted overall benefit score indicates a larger benefit if the associated remedial alternative was implemented, when compared to a remedial alternative with a lower weighted overall benefit score.

Exhibit 5-2: Formula for Weighted Overall Benefit Score

Formula	MTCA Criteria	Weight Factor	Raw Benefit Score
$\text{Weighted Overall Benefit Score} = \sum_{\text{Criteria}} \left(\text{weight factor} * \text{raw benefit score} \right)$	Protectiveness	20%	(0-10)
	Permanence	20%	(0-10)
	Cost	0%	(0-10)
	Long-term Effectiveness	20%	(0-10)
	Short-term Effectiveness	10%	(0-10)
	Implementability	20%	(0-10)
	Consideration of Public Concerns	10%	(0-10)

NOTE:

A Raw Benefit Score between 0 to 10 was estimated for each remedial alternative based on the projected outcomes.

The total cost over the lifetime of the remedial alternative is estimated. An alternative’s costs are considered disproportionate to benefits if the incremental costs of a more permanent alternative are greater than the incremental benefits achieved by that alternative over those of the lower cost alternatives (WAC 173-340-360(3)(e)(i)). This is evaluated using a Benefit/Cost Ratio, where a lower Benefit/Cost Ratio may indicate that the incremental cost is disproportionately large for the incremental benefit (Exhibit 5-3).

Exhibit 5-3: Formula for Benefit/Cost Ratio



$$\text{Benefit/Cost Ratio} = \frac{\text{Weighted Overall Benefit Score}}{\text{Cost}}$$

The estimations, calculations, and rankings of remedial alternatives are summarized in the DCA (Appendix C).

5.5.1 Soil

Remediation alternatives for soil address all saturated and unsaturated soil on the 8801 property that is above the CULs for COCs, except for TCE and vinyl chloride since they are addressed by the groundwater remedial alternatives. Primary COCs are PCBs, cPAHs, and copper.

Table C-1B in the DCA indicates that Alternative 1b (excavation/disposal to RELs with institutional controls) has the greatest benefit for the least cost and is the preferred remedial alternative for soil. This alternative requires soil excavation of heavily contaminated soil and capping with institutional controls to limit potential exposure and migration on the

remaining portions of the property that have COCs exceeding CULs. Although Alternative 1b does not actively promote in-situ remediation of residual soil contamination, some degree of remediation has already occurred (for example, TPH, cPAHs) and more may occur over time via natural attenuation, including biodegradation, volatilization, and dispersion.

Alternative 1a (excavation/disposal to CULs) is more favorable than the preferred alternative for the criteria of overall protectiveness since all contamination exceeding CULs would be removed. However Alternative 1a requires a much larger extent of excavation than the preferred alternative, resulting in:

- About double the cost due to the large quantity of material excavated and disposed offsite,
- Lower implementability due to the larger excavation area and working around existing infrastructure,
- Lower consideration of public concerns since large quantities of contaminated material would be transported through the surrounding area, and
- Lower management of short-term risks since construction workers are more likely to be exposed during a more lengthy and large excavation.

In summary, Alternative 1a has a higher overall weighted benefit score than the preferred alternative; however, the incremental increase in benefit is disproportionate to the increase in cost.

Alternative 1c (excavation/disposal to alternative RELs with institutional controls) is similar to the preferred alternative except the remediation levels for PCBs and cPAHs are more stringent for Alternative 1c. The more stringent remediation levels result in expanding the excavation in Areas 4 and 5 and four additional isolated excavation areas. These additional excavations result in a decrease in management of short-term risks and implementability with no significant increase in other benefit criteria, since the percent of total contaminant mass removed increases by less than 1%. This results in the cost being higher, and overall weighted benefit score being lower, for Alternative 1c when compared to the preferred alternative.

Alternative 1d (cap and institutional controls) requires that all soil that exceeds the saturated soil CULs for the COCs remain in-place and be capped. The cap would be maintained over time and institutional controls would be implemented. When compared to the preferred alternative, Alternative 1d has slightly lower cost since no excavation or disposal would occur but periodic groundwater performance monitoring would still occur, lower overall protectiveness since no contaminants are removed from the 8801 property,

lower permanence since some contaminants will naturally attenuate but others will not, and lower effectiveness over the long term since contamination in soil remains on site and has the potential to leech to groundwater. In summary, Alternative 1d has a lower overall weighted benefit score and cost when compared to the preferred alternative; however, the cost of Alternative 1d is disproportionately high for the overall benefit as indicated by the lower Benefit/Cost Ratio.

5.5.2 Groundwater

Remedial alternatives for groundwater address all groundwater on the 8801 property that is above the CULs for COCs and potential source material, including TCE-impacted soil and PCB-containing caulk. These remedial actions also include controls for potential effects to indoor air from the TCE groundwater plume. Primary COCs are TCE, vinyl chloride, and PCBs.

Table C-2B in the DCA indicates that Alternative 2b (excavate TCE to REL, ERD across TCE/vinyl chloride plume, AS/SVE expansion, PCB-containing chalk removal, and institutional controls for vapor) has the greatest benefit for the least cost and is the preferred remedial alternative for groundwater.

The primary difference between the preferred alternative and Alternative 2a (same list of activities as the preferred alternative except the TCE-related excavation is to the CUL) is the extent of excavation of TCE-impacted soil. The preferred alternatives include excavation of TCE to a REL and capping of residual soil. Excavation to a REL removes about 80% of the total TCE contaminant mass, which significantly reduces the contribution to the TCE/vinyl chloride groundwater plume. The Alternative 2a requires excavation to the CUL, which is more stringent and results in a much larger excavation. The resulting cost is more than double that of the preferred alternative to remove the remaining 20% of contaminant mass, resulting in a disproportionate Benefit/Cost Ratio.

The preferred alternative requires ERD, which accelerates biological degradation of TCE and vinyl chloride in groundwater by injection of a carbon source and dechlorinating bacteria. Alternative 1c implements MNA for the TCE/vinyl chloride groundwater plume resulting in lower effectiveness over the long term and permanence when compared with the preferred alternative. The preferred alternative has a slightly higher cost than Alternative 2c; however, the active remedy (preferred alternative) reduces the restoration timeline, has a higher overall protectiveness, and has a higher permanence. The DCA indicates that the cost of the preferred alternative is proportionate to the incremental benefit.

The primary difference between the preferred alternative and Alternative 2d is the remediation of groundwater downgradient of the existing AS/SVE system. The preferred

alternative requires expansion of the AS/SVE system to the west (downgradient) of the existing AS/SVE system, which will remove additional volatile compounds from the groundwater prior to the water reaching the LDW. Alternative 2d implements MNA for the groundwater downgradient of the existing AS/SVE system resulting in lower overall protectiveness, effectiveness over the long term, and consideration of public concerns when compared to the preferred alternative. The preferred alternative has higher costs from operating the expanded AS/SVE system but a shorter remediation time frame resulting in lower costs over the lifetime of the remedy when compared to Alternative 2d.

5.5.3 Northwest Area

Remedial alternatives for the Northwest Area address impacted groundwater and soil at the northwest corner of the 8801 property. Groundwater in the Northwest Area is impacted by TPH and vinyl chloride. The TPH impacts are largely of diesel- and gasoline-ranges, and their concentrations have historically been high enough to suggest the presence of residual free-phase hydrocarbons. Mobile, or free-phase hydrocarbons, have not, however, been encountered. The vinyl chloride is likely a daughter product from degradation of PCE and TCE groundwater plume.

Table C-3B of the DCA indicates that Alternative 3c (ISCO with MNA) has the greatest benefit for the least costs and is the preferred alternative. In this alternative, ISCO would be used to reduce residual, non-mobile TPH and halogenated VOCs in the Northwest Area of the 8801 property to less than remediation levels. We selected PeroxyChem's Klozur® CR, which is a slurry of self-activating persulfate and calcium peroxide. Klozur® CR performs chemical oxidation of COCs and supports enhanced aerobic remediation. Estimates of cost and time to meet the proposed CULs are based on approximately 17 injection points and up to six injection events followed by one year of groundwater performance monitoring to demonstrate that the RAOs are being met.

Alternative 3a (pump-and-treat) requires a much longer restoration time frame since it does not directly remediate impacted soil. When compared to the preferred alternative, Alternative 3a has lower overall protectiveness and effectiveness over the long term since contaminants may remain on the 8801 property absorbed to soil particles. Alternative 3a also costs more than twice as much as the preferred alternative since periodic costs for a pump and treat system are typically high.

Alternative 3b (Permeable Reactive Barrier) is a passive method which relies on the existing groundwater gradient and flow pattern to transport contaminants in groundwater through the treatment zone. Additionally, Alternative 3b does not directly remediate impacted soil. These factors result in Alternative 3b having a much longer restoration time frame, lower

overall protectiveness, and lower effectiveness over the long term when compared to the preferred alternative.

5.6 Synergistic Effect of Selected Alternatives

The removal of soil hotspots that contain COCs above the human health direct contact levels has the added benefit of reducing the PCE, TCE, and vinyl chloride concentration in both saturated and unsaturated soil. The post remedial property soil concentrations will be less than those required for the protection of construction workers, and in places where excavation has removed PCE, TCE, and vinyl chloride in soil the volume that can partition to groundwater and air will be reduced.

In the area where ERD and ISCO injections will occur, both saturated and unsaturated soil that contains PCE, TCE, and vinyl chloride will be subject to remediation due to the saturation by the selected substrates during injection. In addition, the existing AS/SVE system on the western side of the property and the new extension of the system will remove VOCs from unsaturated soil. The combination of the groundwater treatment technologies contributes to saturated and unsaturated soil remediation and reduces the quantity of VOCs that can be released to the air.

5.6.1 Contingencies

This section discusses the decision points to determine if additional soil and/or groundwater remedial actions are required after the proposed remedy has been put in place.

Groundwater monitoring will be undertaken both to assess the performance of the remedial actions and establish whether the RAOs are being met. The RAOs are to: protect current and future worker exposure to soil contaminants; occupants of future buildings; and the surface water and sediments of the LDW; and achieve remediation of the halogenated VOC groundwater plume in a reasonable timeframe. The groundwater data will be used to establish whether additional remedial actions are required and to assess the restoration timeline.

As previously discussed, soil confirmation samples will be collected to evaluate the effectiveness of soil excavations to the remediation levels in removing most of the COC mass in soil. Three of the excavations (Excavations 3, 4, and 5) are close to the property boundary with the LDW. Groundwater for some of the COC concentrations from monitoring wells adjacent to these locations have exceeded their respective CULs. Excavation work is expected to disturb the soil and groundwater equilibrium resulting in temporary impacts to groundwater. Contaminants adsorbed to the finer soil particles may temporarily increase contaminant concentrations in total groundwater samples immediately after the excavation activities. Because it may take up to a year before this disturbance effect

diminishes and the soil/groundwater equilibrium is restored, contingency actions will not be evaluated until after a minimum of four groundwater monitoring events associated with the excavation activities. Therefore, the timeline for consideration of actions associated with the excavation areas will be over a greater time-period than for groundwater remedial actions. Detection of chemicals associated with the laboratory's ability to achieve lower detection limits and consequently result in a detection where previous samples were non-detect are not considered applicable to the triggers discussed below. Triggers and potential actions that will be considered for soil commencing one year after excavation work are:

- If total PCB aroclors are detected in the point of compliance wells for more than three consecutive sampling events at concentrations greater than cleanup criteria and do not show a declining trend in concentration, a discussion with Ecology regarding additional alternatives such as excavation will be undertaken.

Within the halogenated VOC groundwater plume, the reagents injected have a designed lifespan of approximately two to four years and will impact groundwater both near and downgradient of the injection point. Triggers to consider for additional action or consideration of other alternatives in the halogenated VOC plume are:

- If the maximum concentration of TCE has not declined by up to 80% to 90% within three years and the geochemistry demonstrates that dechlorination is still occurring, re-injection of the ERD compounds or other stimulate compounds will be considered.
- If vinyl chloride increases are greater than those predicted from the mass conversion of the remaining TCE or the concentrations stall, alternative injection substrates may be considered. These could include, but are not limited to, permanganate, peroxide, or persulfate (all compounds considered or selected for the vinyl chloride treatment in the north west corner).

Since a large building is proposed to be constructed over much of the 8801 property, including part of the halogenated VOC plume in the next few years, some alternative injection points may need to be established to address on-going remedial actions. Once the building has been constructed, if remedial action is still necessary, injection points will be placed alongside the exterior of the structure and wells downgradient of the building will be monitored.

On the western edge of the plume, vinyl chloride is being addressed with the existing AS/SVE system and the proposed extension of the AS/SVE system. The proposed AS/SVE extension is designed to perform downgradient groundwater polishing for the existing system and will further decrease the halogenated VOC concentrations, if any remains. If the CULs are achieved between the existing system and the extension, the AS/SVE extension will be deactivated and will act as a contingency for the main system. The northern and

southern AS/SVE system wellfield legs of the existing AS/SVE system can also be independently shutdown if CULs are achieved upgradient of these legs.

Cleanup of vinyl chloride and lighter petroleum hydrocarbons in the northwest corner will be undertaken. Triggers to consider for additional action or consideration of other alternatives in the northwest area are:

- If vinyl chloride concentrations exceed the CULs at MW-7A (upgradient) and MW-44A (within the injection area) after three injection periods (if three injections are undertaken as they may not all be required), consideration of other options, such as alternative injection compounds, will be discussed with Ecology.
- If hydrocarbon concentrations exceed the CULs at MW-44A after three injection periods (if three injections are undertaken as they may not all be required), consideration of other options, such as alternative injection compounds, will be discussed with Ecology.

5.6.2 Institutional Controls

After remedial alternatives have been implemented, institutional controls will be required as follows:

1. Ensure that 8801 property groundwater is not used for drinking water and
2. Maintain surface cover throughout the property to minimize stormwater infiltration.

The institutional controls will comply with the Uniform Environmental Covenants Act , Chapter 64.70 of the revised code of Washington.

6 COMPLIANCE MONITORING AND SCHEDULE

This section discusses the compliance monitoring that will be undertaken to demonstrate compliance with MTCA, and the schedule for implementing the remedial activities.

Three types of compliance monitoring are identified for interim or remedial cleanup actions performed under MTCA (WAC 173-340-410): Protection, Performance, and Compliance Monitoring. The definition of each is presented below (WAC 173-340-410 [1]):

- Protection Monitoring – To confirm that human health and the environment are adequately protected during construction and the operation and maintenance period of an interim action or cleanup action as described in the safety and health plan.
- Performance Monitoring – To confirm that the cleanup action has attained cleanup standards and other performance standards, such as construction quality control measurements or monitoring necessary to demonstrate compliance with a permit or, where a permit exemption applies, the substantive requirements of other laws.

- Confirmation Monitoring – To confirm the long-term effectiveness of the cleanup action once cleanup standards and other performance standards have been attained.

This cleanup action will involve all three types of monitoring. Each type of monitoring to be implemented at the 8801 property is discussed below. A monitoring plan with additional detail will be submitted with the engineering design report.

6.1 Protection Monitoring

A separate health and safety plan (HASP) will be prepared for the cleanup action that meets the minimum requirements for such a plan identified in federal (29 Code of Federal Regulations 1910.120, and 1926) and state (WAC 296) regulations. The protection monitoring will include personal and perimeter air sampling for lead and VOC during earthwork. The frequency of sampling and period of monitoring will be established in the HASP.

A site-specific Stormwater Pollution Prevention Plan (SWPPP) already exists for the current IAAI operations. The Best Management Practices (BMPs) associated with the SWPPP are required to be maintained by the existing operator. A temporary erosion and sedimentation control plan, including BMPs associated with the excavation work, will be established prior to work commencing.

6.2 Performance Monitoring

The objectives for performance monitoring are to demonstrate compliance with the MTCA cleanup regulations and City permit specifications, and to document the property conditions upon completion of the cleanup action. To demonstrate such compliance, the following separate performance monitoring activities are planned during the IAWP implementation:

- Create a waste profile for off-site treatment or disposal;
- Confirm that RELs have been achieved within the sidewalls and bottom of hotspot excavations;
- Determine the suitability of imported fill material and compaction;
- Monitor the performance of the AS/SVE system, ERD, and ISCO injections; and
- Monitor groundwater to determine if completed groundwater and soil remedial actions have attained groundwater cleanup at the conditional POC.

6.2.1 Waste Profile for Off-Site Treatment or Disposal

Wastes generated during the implementation of the IAWP will require characterization and profiling before shipment off site. Usually, the receiving facility specifies the minimum number of samples and analytical tests. Wastes that will be generated during the IAWP implementation will include:

- Excavated soil (characterization will be required for the different areas of concern),
- Soil cuttings generated during drilling,
- By-products generated during injection,
- Purge water,
- Miscellaneous solid wastes, and
- Emissions generated during operation of the AS/SVE system.

Each waste stream will be profiled separately in accordance with the minimum waste analysis requirements of the respective receiving facility.

6.2.2 Excavation Performance Monitoring

Except where the limits of the excavation have been delineated by previous investigation work, confirmation soil samples will be collected from the sidewalls and bottoms of each excavation area. In shallow excavations above the groundwater table, the four sidewalls and the bottom will be sampled. Samples will be collected on 20-foot centers from the sidewalls and bottom of each excavation area with a minimum of one sample collected from each sidewall and base (if no previous sample has been collected) as outlined below:

- If the final excavation depth is 4 feet or less, a minimum of one sample from each sidewall will be collected within the contaminant horizon identified during previous investigation or as noted during field observation.
- If the final excavation depth exceeds 4 feet, a minimum of one sample from each sidewall will be collected from the center (or within the contaminant horizon) of each 3-foot-thick (or portion of each) vertical layer. The thickness of the individual sample layers may be reduced to allow for more even sample distribution or accommodate field observations. For example, two samples from each sidewall when the excavation depth is 8 feet.
- Regardless of the total depth of the excavation, a sample from each fill layer observed in the excavation will be collected from each sidewall. This may require collection of additional sidewall samples.
- Bottom samples will be collected on a 20-foot grid in excavations where groundwater is not encountered.

- When groundwater is encountered during the excavation, the lowermost sidewall sample will be assumed to represent conditions at the water table.

The goal of the excavations is to remove soil above RELs and sample results will be used to extend the excavation if one or more COCs that exceed the REL are identified. Samples collected will be analyzed for the COCs previously documented in that location. If a value exceeds the REL as discussed above, then the area represented by the sample will be overexcavated a minimum of 1 additional foot, and subsequently resampled and tested for the COC with the exceedance. This step procedure will be followed until the performance samples document that RELs have been attained or logistical constraints (e.g., underground infrastructure) limit the excavation. If confirmation samples collected at or near the water table exceed RELs, nonaqueous-phase liquids are encountered, or field observations or previous sample results suggest that impacts extend beyond the water table, the vertical limits of the excavation will be extended below the water table to remove all contamination above RELs. Impacts will be assumed to extend below the water table if CUL is exceeded in a base sample collected just above the water table or in a lowermost sidewall sample.

Groundwater samples will also be collected after remedial activities have been initiated to verify that the activities are reducing concentrations of COCs in groundwater. Remediation associated groundwater monitoring will be undertaken as discussed in Section 6.3 (Performance and Confirmation Monitoring).

6.2.3 Performance Monitoring of the Suitability of Imported Fill Material and Compaction

Imported fill will be tested for geotechnical properties to confirm its structural integrity for future site development and analyzed for the primary COCs and other analytes that are deemed appropriate, such as arsenic. Soil will be tested to ensure that no PCBs or TPH are present and that cPAHs, lead, arsenic, and copper do not exceed the REL. It is assumed that a minimum of one sample from every type of material or every 5,000 tons will be tested. Samples failing geotechnical performance criteria or showing exceedance of any analyte will be rejected.

Compaction testing of the fill will also be performed. The compacted fill will be tested so that a minimum of 95% of the maximum dry density, as determined by ASTM D-1557, is achieved. The moisture content will be monitored during site placement and compaction.

6.2.4 Performance Monitoring of Air Sparge/Soil Vapor Extraction (AS/SVE), Enhanced Reductive Dechlorination (ERD), and In Situ Chemical Oxidation (ISCO) Groundwater Treatment Systems

Performance monitoring of the groundwater treatment systems included as part of the selected alternative will involve monitoring of the systems' input and output parameters to ensure the systems are functioning as designed and to allow modifications to increase the systems' effectiveness and monitoring systems' effects on groundwater quality. Monitoring of system parameters will be more fully identified during preparation of the engineering design and fully documented in a subsequent Operation and Maintenance Manual for each system. Groundwater performance monitoring is discussed in more detail below.

6.3 Groundwater Performance and Confirmation Monitoring

Groundwater samples will be collected from the existing monitoring well network and newly installed monitoring wells located downgradient of the remediated areas of concern following completion of the soil excavation and groundwater treatment. The proposed wells to be sampled and the analyses are provided in Table 6 for performance monitoring and in Table 7 for compliance monitoring. The locations of the proposed compliance and performance wells are shown in Figure 8.

During remedial activities to address halogenated VOCs in groundwater, samples will be collected four months after an injection event at the wells shown in Figure 8. The well locations are within and downgradient of the proposed injection area. Samples will be analyzed for halogenated VOCs to determine if the RELs have been achieved.

During remedial activities for groundwater in the northwest area, samples at wells MW-44A and IT-MW-7 will be collected four months after the ISCO event. Samples will be analyzed for TPH, and VOCs to determine if CULs have been achieved.

Verifying remedial activities for the area where PCB containing caulk will be removed will consist of sampling monitoring wells MW-16A and MW-34A for PCB aroclor analysis.

The groundwater data collected from the performance wells will be assessed for the risk to vapor intrusion. Following construction of the proposed new building, indoor air samples will be collected on a quarterly to annual basis to ensure the mitigation measures are effective.

Groundwater samples will be collected from the compliance wells along the LDW property boundary to determine if CULs have been achieved. Compliance monitoring is proposed using monitoring wells MW-26A; MW-29A, and B; MW-30A; MW-35A; MW-36A and B; MW-37A and B; MW-43AR (a replacement well for MW-43A, which will be removed during

remediation activities), MW-44A, MW-50A (a new well that will be installed in the southwest corner of the 8801 property), and the well on the northern property IT-MW-7. These wells are located adjacent to the POC and will be sampled on a quarterly basis for the two years after active remediation has been completed. The frequency of monitoring will then be assessed.

6.4 Schedule for Implementation

The cleanup actions described in this IAWP will be completed after review by Ecology, EPA, and the public. In accordance with the schedule specified in the AO, an engineering design report will be provided for review by Ecology after the IAWP is approved.

Following Ecology's approval, it is proposed to implement the excavation and first injection event within one year. Performance monitoring will then be used to determine whether additional injections are required. It is anticipated that at least two more ISCO injections will be required and that one more EDR injection may be required. These will likely be undertaken within one to three years after the initial injections. Compliance monitoring will then commence.

7 LIMITATIONS

This report was prepared exclusively for PACCAR by Shannon & Wilson, Inc. The quality of information, conclusions, and estimates contained herein are consistent with the level of effort involved in our services and based on (a) information available at the time of preparation; (b) data supplied by outside sources; and (c) the assumptions, conditions, and qualifications set forth in this report and our proposal. This report is intended to be used for the 8801 property only, subject to the terms and conditions of the contract. Any other use of, or reliance on, this report by any third party is at the sole risk of that party.

8 REFERENCES

Amec Earth & Environmental, Inc. (Amec), 2011, Final remedial investigation report, 8801 East Marginal Way South, Tukwila, Washington, agreed order number 6069: Report prepared by Amec Earth & Environmental, Inc., Bothell, Wash., 9-915-14995-L, for PACCAR Inc., Bellevue, Wash., March 18.

Amec Environment & Infrastructure, Inc. (Amec), 2013, Ecology review - final focused feasibility study, 8801 East Marginal Way South, Tukwila, Washington, agreed order no. 6069: Report prepared by Amec Earth & Environmental, Inc., Bothell, Wash., 9-915-14995-L, for PACCAR Inc., May 30.

- Anchor Environmental, LLC (Anchor), 2008a, Evaluation of tidal influence on groundwater elevations at 8801 Marginal Way South: Technical memorandum prepared by Anchor Environmental, L. L. C., Seattle, Wash., for PACCAR Inc, February 14.
- Anchor Environmental, LLC (Anchor), 2008b, Phase 2 SEWP surface and subsurface sediment results at 8801 Marginal Way South (draft): Technical memorandum prepared by Anchor Environmental, LLC, Seattle, Wash., for PACCAR Inc, May 12.
- GeoEngineers, Inc. and Kennedy/Jenks/Chilton, 1990, Remedial feasibility assessment, subsurface solvent contamination, north fire aisle, Kenworth Truck manufacturing facility, Tukwila, Washington: Report prepared by GeoEngineers, Inc., Bellevue, Wash., and Kennedy/Jenks/Chilton, for Kenworth Truck Company, May 25.
- Geomatrix Consultants Inc., 2007, Northwest Corner Affected Soil Removal Report, Former Rhône-Poulenc Site, Tukwila, Washington: Report prepared by Geomatrix Consultants Inc., Seattle, Wash., 8769, for Container Properties LLC, January.
- Kennedy/Jenks Consultants (Kennedy/Jenks), 1998, Interim VOC investigation report, 8801 East Marginal Way South, Tukwila, Washington: Report prepared by Kennedy/Jenks Consultants, Federal Way, Wash., K/J 956085.07, for the Kenworth Truck Company, June.
- Leidos, Inc. (Leidos), 2016, Technical Memorandum: Potential for PCB contamination from sampling equipment tubing materials: Memorandum prepared by Leidos, Inc., Bothell, Wash., November 23.
- Leidos, Inc. (Leidos), 2017, Lower Duwamish Waterway groundwater sampling for PCB congeners and aroclors, data report, final: Report prepared by Leidos, Inc., Bothell, Wash. for the Washington State Department of Ecology, Bellevue, Wash., July.
- Shannon & Wilson, Inc., 2019, Public review draft feasibility study for 8801 East Marginal Way S, Tukwila, Wash.: Report prepared by Shannon & Wilson, Inc., 21-1-12567-010, for PACCAR Inc, June.
- U.S. Environmental Protection Agency (EPA), 2014, Record of decision, Lower Duwamish Waterway superfund site: Seattle, Wash., U.S. Environmental Protection Agency Region 10, November.
- U.S. Environmental Protection Agency (EPA), 2017, EPA spreadsheet for modeling subsurface vapor intrusion: Washington, D. C., EPA, available: <https://www.epa.gov/vaporintrusion/epa-spreadsheet-modeling-subsurface-vapor-intrusion>, accessed October 2017.

Washington State Department of Ecology (Ecology), 2013, Model toxics control act regulation and statute: MTCA cleanup regulation, chapter 173-340 WAC; model toxics control act, chapter 70.105D RCW; uniform environmental covenants act, chapter 64.70 RCW (rev.): Olympia, Wash., Washington Dept. of Ecology, Publication no. 94.06, 324 p., available:

<https://fortress.wa.gov/ecy/publications/summarypages/9406.html>.

Washington State Department of Ecology (Ecology), 2018, Lower Duwamish Waterway preliminary cleanup level workbook, supplemental information (PCUL document): Washington State Department of Ecology, 54 p., December.

Windward Environmental, LLC (Windward), 2011, Stormwater system investigation – final report, Insurance Auto Auctions, 8801 E Marginal Way S, Tukwila, Washington: Report prepared by Windward Environmental, LLC, Seattle, Wash., for Washington State Department of Ecology, Bellevue, Wash., May 20.

Table 1 - Cleanup Levels

Analyte	Soil – Protection of Sediment or Surface Water ^a (mg/kg)	Soil - Background (mg/kg)	Human Health – MTCA Method A or B ^b (mg/kg)	Practical Quantitation Limit (mg/kg)	Soil – Protective of Vapor ^c (mg/kg)	Groundwater ^a (µg/L)	Groundwater – Protective of Indoor Air ^b (µg/L)	Practical Quantitation Limit (µg/L)	MTCA Method B Indoor Air ^b (µg/m ³)
Arsenic	—	7.3	—	—	—	8	—	—	—
Bis(2-ethylhexyl)phthalate	0.005/0.1	—	—	0.12	—	0.046	—	0.2	—
Cadmium	5.1	—	—	—	—	—	—	—	—
Chromium	2,600	—	—	—	—	—	—	—	—
Copper	—	36	—	—	—	3.1	—	—	—
Dichloroethane, 1,1-	—	—	—	—	—	—	11	—	1.56
Diesel-range hydrocarbons	—	—	—	—	—	500 ^d	—	—	—
Dioxin/furan TEQ	—	0.0000052	—	—	—	—	—	—	—
Gasoline-range hydrocarbons	—	—	100	—	250	1,000 ^d	—	—	1,400
Hexavalent chromium	0.096/19	—	—	—	—	50	—	—	—
Lead	—	—	250	—	—	—	—	—	—
Oil-range hydrocarbons	—	—	2,000	—	—	500 ^d	—	—	—
Tetrachloroethene	0.0016	—	—	—	—	2.9	—	—	9.62
Total cPAHs TEQ	0.0000022	—	—	0.005	—	0.000016	—	0.01	—
Total PCB aroclors	0.0000022	—	—	0.002	—	0.000007	—	0.01	—
Trichloroethene	0.00027/0.0044	—	—	0.001	—	0.7	—	—	0.37
Vinyl chloride (chloroethylene)	0.000055 /0.001	—	—	0.001	—	0.18	—	—	0.28

NOTES:

- a. Washington State Department of Ecology's (Ecology's) Lower Duwamish Waterway (LDW) Preliminary Cleanup Levels (PCUL) Work Book (Ecology, 2018). Soil values are based on protection of sediment or surface water via leaching from saturated/unsaturated soil into non-potable groundwater or from bank spall at locations close to water (cadmium and chromium). The first value is saturated soil and the second value is unsaturated soil.
- b. Model Toxics Control Act (MTCA) Method A or B levels from the CLARC database (March 2019).
- c. Ecology Implementation Memo 14: Updated process for initially assessing the potential for petroleum vapor intrusion. March 2016.
- d. A1 boring area is the one area with gasoline impacted groundwater and the adjacent well MW-44A is the only location with diesel and oil impacted groundwater in 2019.

Bold = Selected proposed cleanup level for chemical in the media.

— = Not a selected cleanup level and/or chemical of concern for this media; cPAHs = carcinogenic polycyclic aromatic hydrocarbons; mg/kg = milligrams per kilogram; PCB = polychlorinated biphenyl; TEQ = toxicity equivalency quotient; $\mu\text{g}/\text{L}$ = micrograms per liter; $\mu\text{g}/\text{m}^3$ = micrograms per meter cubed

Table 2 - Soil Remediation Levels

Analyte	Human Health Method B Carcinogen ^a (mg/kg)	Human Health Method B Non-Carcinogen ^a (mg/kg)	Human Health Modified Method B ^b (mg/kg)	Proposed Remediation Level ^c (mg/kg)
Arsenic	—	—	—	14.6
Bis(2-ethylhexyl)phthalate	71.4	1,600	—	71.4
Copper	—	3,200	—	3,200
Gasoline-range hydrocarbons	—	—	1,600	250/1,000
Oil-range hydrocarbons	—	—	—	4,000
Tetrachloroethene	476	480	—	12
Total cPAHs TEQ	—	—	0.57	0.6
Total PCB aroclors	—	—	2.08	1
Trichloroethene	12	40	—	12
Vinyl chloride	0.67	—	—	5

NOTES:

- Model Toxics Control Act (MTCA) Method B direct contact levels from the CLARC database (March 2019).
- See text for explanation of calculated modified Method B based on adult worker exposure (70 kilograms body weight).
- Selected level is based on either human health, a value equal to or more protective of the modified Method B value, or a selected value that will result in reduction of mass to aid in the cleanup of groundwater (tetrachloroethene, trichloroethene and vinyl chloride).

— = Not a value selected for this media; cPAHs = carcinogenic polycyclic aromatic hydrocarbons; mg/kg = milligrams per kilogram; PCB = polychlorinated biphenyl; TEQ = toxicity equivalency quotient

Table 3 – Soil Chemicals of Concern Mass Calculations

Chemical	Remediation Level (mg/kg)	Mass of COCs on Site (kg)	Mass of COCs Removed from	
			Proposed Excavations (kg)	% Total COCs Removed
Polychlorinated biphenyls	0.5	0.098	0.078	80.0
Carcinogenic polycyclic aromatic hydrocarbons	0.6	0.080	0.063	79.5
Arsenic	14.6	2.03	1.32	65.0
Copper	250	104	95.8	92.1
Trichloroethene	5	1.034	0.835	80.8
Total		107.24	98.10	91.5

NOTE:

COCs = chemicals of concern; kg = kilograms; mg/kg = milligrams per kilogram

Table 4 - Proposed Halogenated Volatile Organic Compounds Groundwater Remediation Levels

Area	Trichloroethene (µg/l)	Vinyl Chloride (µg/l)
Plume at MW-14A/G0	5	1
Plume east of existing AS/SVE	1	0.5

NOTE:

AS/SVE = air sparing/soil vapor extraction; µg/l = micrograms per liter

Table 5 – Summary of Chemicals of Concern, Areas of Concern, and Selected Remedies

Analyte	Soil				Groundwater				Air			
	COC Location(s) ^a	Area of Concern Location(s) ^b	Selected Remedy ^c	Comment	COC Location(s) ^a	Area of Concern Location(s) ^b	Selected Remedy ^c	Comment	COC Location(s) ^a	Area of Concern Location(s) ^b	Selected Remedy ^c	Comment
Arsenic	SFA-S15-3 and BY-3	SFA-S15-3 (Area 6) and BY-3 (Area 5)	Removal (Areas 5 and 6)	—	—	—	—	—	—	—	—	—
Bis(2-ethylhexyl) phthalate	Sitewide	—	—	Below proposed RL	Sitewide	—	—	Isolated detections; no indication of migration; ongoing monitoring	—	—	—	—
Cadmium	BY-1	BY-1 (Area 5)	Removal (Area 5)	—	—	—	—	—	—	—	—	—
Chromium	BY-1	—	—	Below CUL; will be removed with Area 5 exc.	—	—	—	—	—	—	—	—
Copper	Sitewide	DG11-11 (Area 3)	Removal (Area 3)	—	HVOC plume	HVOC plume	HVOC Remedy	Indirect concurrent with HVOCs; ongoing monitoring	—	—	—	—
Dichloroethane, 1,1-	—	—	—	—	MW-15A	MW-15A	ERD	—	MW-15A	MW-15A	Sub-slab Depress. and Vapor Barrier	May not be required
Diesel-range hydrocarbons	—	—	—	—	Vicinity of A1 (A1 and MW-44A)	Vicinity of A1 (A1 and MW-44A)	ISCO	—	—	—	—	—
Gasoline-range hydrocarbons	Vicinity of A1, DG11-12, and FWW-1	Vicinity of A1 DG11-12 (Area 3)	ISCO Removal (Area 3)	— —	Vicinity of A1 (A1)	Vicinity of A1 (A1)	ISCO	—	FWW-1	FWW-1 (Area 7)	Removal	—
Hexavalent chromium	WP-4 and WP-6	WP-4 and WP-6	Removal (Contingent)	Contingent on groundwater sampling	—	—	—	—	—	—	—	—
Lead	Former southwest storage area and B3	Former southwest storage area (Area 5) B3	Removal (Area 5) Inaccessible	— Below remediation system	—	—	—	—	—	—	—	—
Oil-range hydrocarbons	E7-S2-2 and former southwest storage area	E7-S2-2 Former southwest storage area (Area 5)	ISCO Removal (Area 5)	— —	Vicinity of A1 (A1 and MW-44A)	Vicinity of A1 (A1 and MW-44A)	ISCO	—	—	—	—	—
Tetrachloroethene	HVOC plume	—	—	Below proposed RL	HVOC plume	HVOC plume	ERD, ISCO, AS/SVE Ext.	—	—	—	—	—
Total cPAHs TEQ	Sitewide	EH4-S-1.5 and EH4-W-1.5 (Area 2) and DS-2 (Area 5)	Removal (Areas 2 and 5)	—	Sitewide	—	—	No AOCs identified ^d	—	—	—	—
Total dioxins/furans TEQ	C6 and DG11-1	C6 and DG11-1 (Area 4)	Removal (Area 4)	—	—	—	—	—	—	—	—	—
Total PCB aroclors	Sitewide	DG11-1 (Area 4) SSBOT-03 SWS-1 (Area 5) DG11-11 (Area 3)	Removal (Area 4) Inaccessible Removal (Area 5) Removal (Area 3)	— Below stormwater vault — —	MW-16A, MW-30A, MW-34A	MW-16A and MW-34A MW-30A	PCB-Caulk Removal Removal	— Will be addressed by Area 5 exc.	—	—	—	—
Trichloroethene	HVOC plume	G0 (Area 1)	Removal (Area 1)	—	HVOC plume	HVOC plume	ERD, ISCO, AS/SVE Ext.	—	HVOC plume	HVOC plume	Sub-slab Depress. and Vapor Barrier	May not be required
Vinyl chloride	HVOC plume	—	—	Below proposed RL	HVOC plume	HVOC plume	ERD, ISCO, AS/SVE Ext.	—	HVOC plume	HVOC plume	Sub-slab Depress. and Vapor Barrier	May not be required

NOTES:

- a. Location(s) at which the analyte has been retained as a COC. See Tables 3 and 4 for COC evaluation for soil and groundwater, respectively.
- b. AOC location(s) at which the compound is present at levels above proposed remediation level.
- c. Selected remedy to address the analyte at the AOC.
- d. Though total cPAHs TEQ is a sitewide COC in groundwater, wells in which detections exceeded two times the cleanup level were either subsequently sampled with results below two times the cleanup level or were at locations with other nearby downgradient monitoring wells to demonstrate that contamination at the well is not migrating. Therefore, no AOC was identified for total cPAHs TEQ.

— = Not applicable; AOC = area of concern; AS/SVE = air stripping/soil vapor extraction; COC = chemical of concern; cPAHs = carcinogenic polycyclic aromatic hydrocarbons; Depress. = depressurization; ERD = enhanced reductive dechlorination; Exc. = excavation; Ext. = extension; ISCO = in-situ chemical oxidation; PCB = polychlorinated biphenyl; RL = remediation level; TEQ = toxicity equivalency quotient

Table 6 - Performance Monitoring

Type	Location Name	Location Description	Rationale	Groundwater Analyses							
				TPH-G	TPH-Dx	BTEX	HVOCs	PCB Aroclors	PCB Congener	Copper	
Groundwater Monitoring Well	MW-16A	North of main warehouse	North of main warehouse		x				x	x*	
	MW-34A	North of main warehouse	North of main warehouse		x				x	x*	
	IT-MW-6	Boeing property north of MW-46A	Boeing property north of MW-46A					x			
	MW-12A	South of proposed new building	South of proposed new building					x			
	MW-12A	South limit of western edge of HVOC plume	South limit of western edge of HVOC plume					x			
	MW-14A	North of proposed new building	North of proposed new building					x			
	MW-25A	Northern property near northwest corner	Northern property near northwest corner					x			
	MW-47A	Center of site and center of plume	Center of site and center of plume					x			
	IT-MW-7	Boeing property western side	Boeing property western side					x			
	MW-7A	East of small warehouse near northwest corner	East of small warehouse near northwest corner		x	x	x	x			
	MW-44A	Northwest corner	Northwest corner		x	x	x	x			
	MW-41A	Southwest north of property boundary	Copper detected above threshold					x			x

NOTES:

* Monitor aroclors till non-detect achieved and then run congener analysis to demonstrate compliance.

Boeing = The Boeing Company; BTEX = benzene, toluene, ethylbenzene, and xylenes; HVOCs = halogenated volatile organic compounds; PCBs = polychlorinated biphenyls; TPH = total petroleum hydrocarbons; TPH-Dx = total petroleum hydrocarbons diesel extended; TPH-G = gasoline-range petroleum hydrocarbons

Table 7 - Compliance Monitoring

Type	Location Name	Location Description	Rationale	Groundwater Analyses				
				TPH-G	TPH-Dx	Aroclors*	HVOCs	Copper
Groundwater Monitoring Well	IT-MW-7	Boeing property western side	HVOC evaluation				X	
	MW-44A	Northwest corner	HVOC, and TPH evaluation	X	X	X	X	
	MW-35A	Small warehouse	HVOC evaluation				X	
	MW-26A	Small warehouse	HVOC evaluation				X	
	MW-36A	South of small warehouse	HVOC evaluation				X	
	MW-36B	South of small warehouse	HVOC evaluation				X	
	MW-29A	South of small warehouse	HVOC evaluation				X	
	MW-29B	South of small warehouse	HVOC evaluation				X	
	MW-37A	End of sheet pile wall	HVOC evaluation				X	
	MW-37B	End of sheet pile wall	HVOC evaluation				X	
	MW-43AR	South west storage area	HVOC, TPH, PCB, and copper evaluation	X	X	X	X	X
	MW-30A	South of south west storage area	HVOC, TPH, PCB, and copper evaluation	X	X	X	X	X

NOTES:

* Congener analysis may be undertaken on some samples prior to completion of the quarterly monitoring.

Boeing = The Boeing Company; BTEX = benzene, toluene, ethylbenzene, and xylenes; HVOCs = halogenated volatile organic compounds; PCBs = polychlorinated biphenyls; TPH = total petroleum hydrocarbons; TPH-Dx = total petroleum hydrocarbons diesel extended; TPH-G = gasoline-range petroleum hydrocarbons

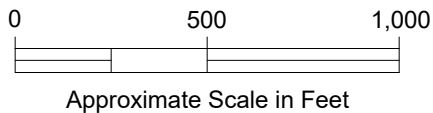
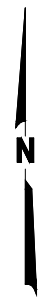

NOTE

Bing Map Image adapted from aerial imagery provided by Autodesk Live Maps and Microsoft Bing Maps reprinted with permission from Microsoft Corporation.

8801 East Marginal Way South
Tukwila, Washington

VICINITY MAP

June 2019

21-1-12567-014

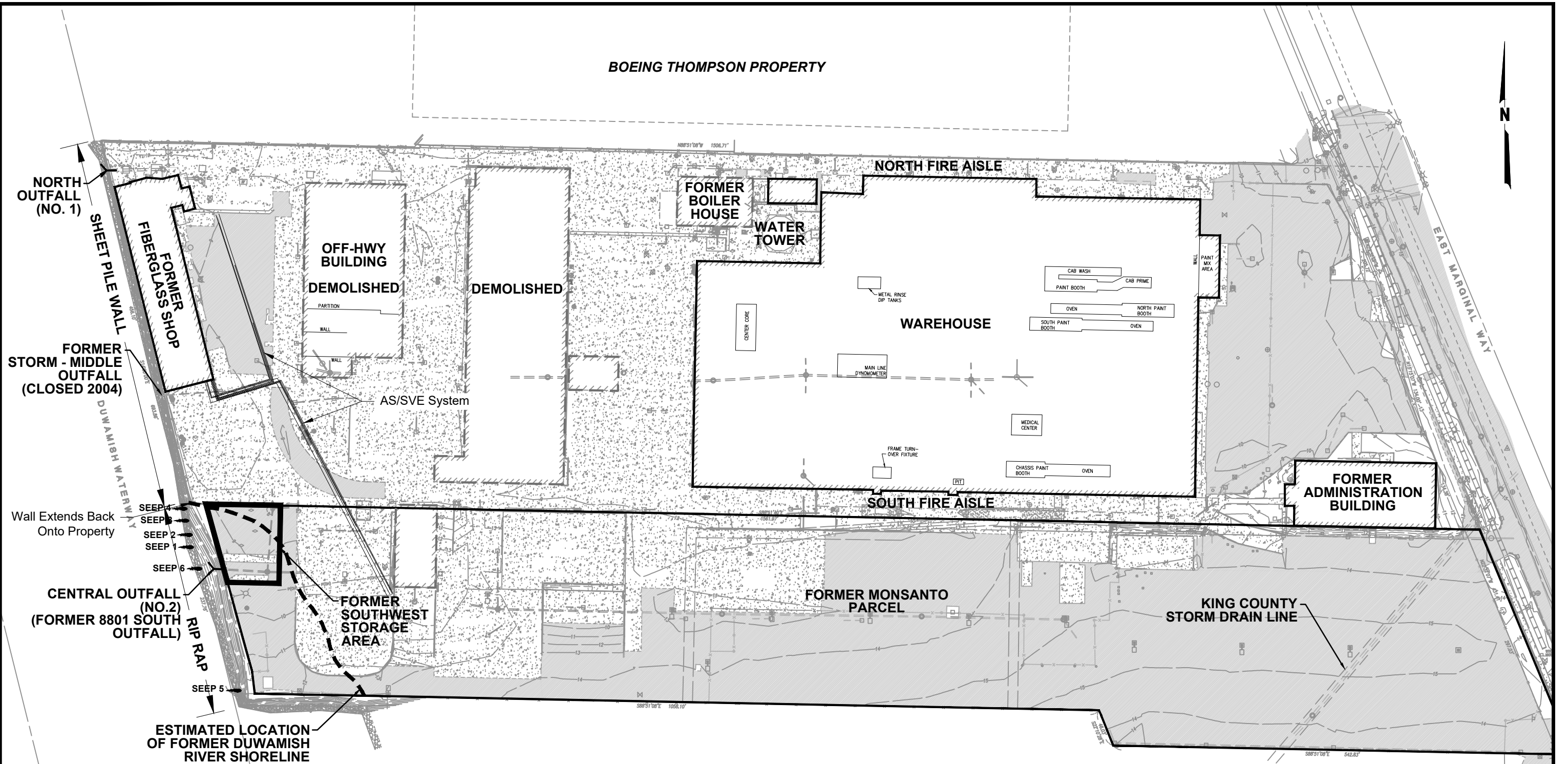

Filename: J:\21112567\014\21-1-12567-014 Key Site Features.dwg Layout: Figure 2-FS Date: 05-31-2019 Login: JRS

BOEING THOMPSON PROPERTY



NORTH OUTFALL (NO. 1)

FORMER STORM - MIDDLE OUTFALL (CLOSED 2004)

Wall Extends Back Onto Property

CENTRAL OUTFALL (NO.2) (FORMER 8801 SOUTH OUTFALL)

ESTIMATED LOCATION OF FORMER DUWAMISH RIVER SHORELINE

CONTAINER PROPERTIES LLC



(INSURANCE AUTO AUCTIONS INCORPORATED VEHICLE STORAGE ON BOTH 8801 AND CONTAINER PROPERTIES PARCELS)

MUSEUM OF FLIGHT

NOTE

Figure adapted from AMEC 14995-L-32.dwg dated 05/2013, and 14995-L-16.dwg dated November 2010.

LEGEND

-  Existing Buildings
-  Former Buildings
- AS/SVE Air Sparge/Soil Vapor Extraction



8801 East Marginal Way South Tukwila, Washington	
KEY PROPERTY FEATURES	
June 2019	21-1-12567-014
 SHANNON & WILSON, INC. GEOTECHNICAL AND ENVIRONMENTAL CONSULTANTS	FIG. 2

Filename: J:\21112567\014\21-1-12567-014 Monitoring Wells.dwg Layout: Figure 3-FS Date: 05-31-2019 Login: JRS



- LEGEND**
- MONITORING WELLS
 - A - SCREEN INSTALLED IN ZONE A AQUIFER
 - B - SCREEN INSTALLED IN ZONE B AQUIFER
 - C - SCREEN INSTALLED IN ZONE C AQUIFER
 - RECOVERY WELLS
 - WELLS REMOVED OR COVERED

- LEGEND**
- Conceptual Building Footprint
 - Conceptual Canopy
 - Shoreline Buffer

NOTE: LOCATION OF MW-17 WAS NOT IDENTIFIED IN PREVIOUS INVESTIGATION REPORTS.

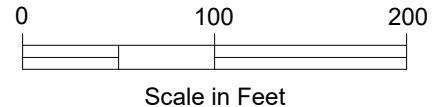

NOTE
Figure adapted from AMEC 14995-L-37.dwg dated 05/2013.

8801 East Marginal Way South
Tukwila, Washington

PROPOSED DEVELOPMENT

June 2019 21-1-12567-014

SHANNON & WILSON INC.
ENGINEERING AND ENVIRONMENTAL CONSULTANTS

FIG. 3

Filename: \\sea-fs1\Drafting\21112567014\21-1-12567-014 GW 2011-09-27.dwg Layout: Figure 4-IAWP Date: 06-03-2019 Login: JRS

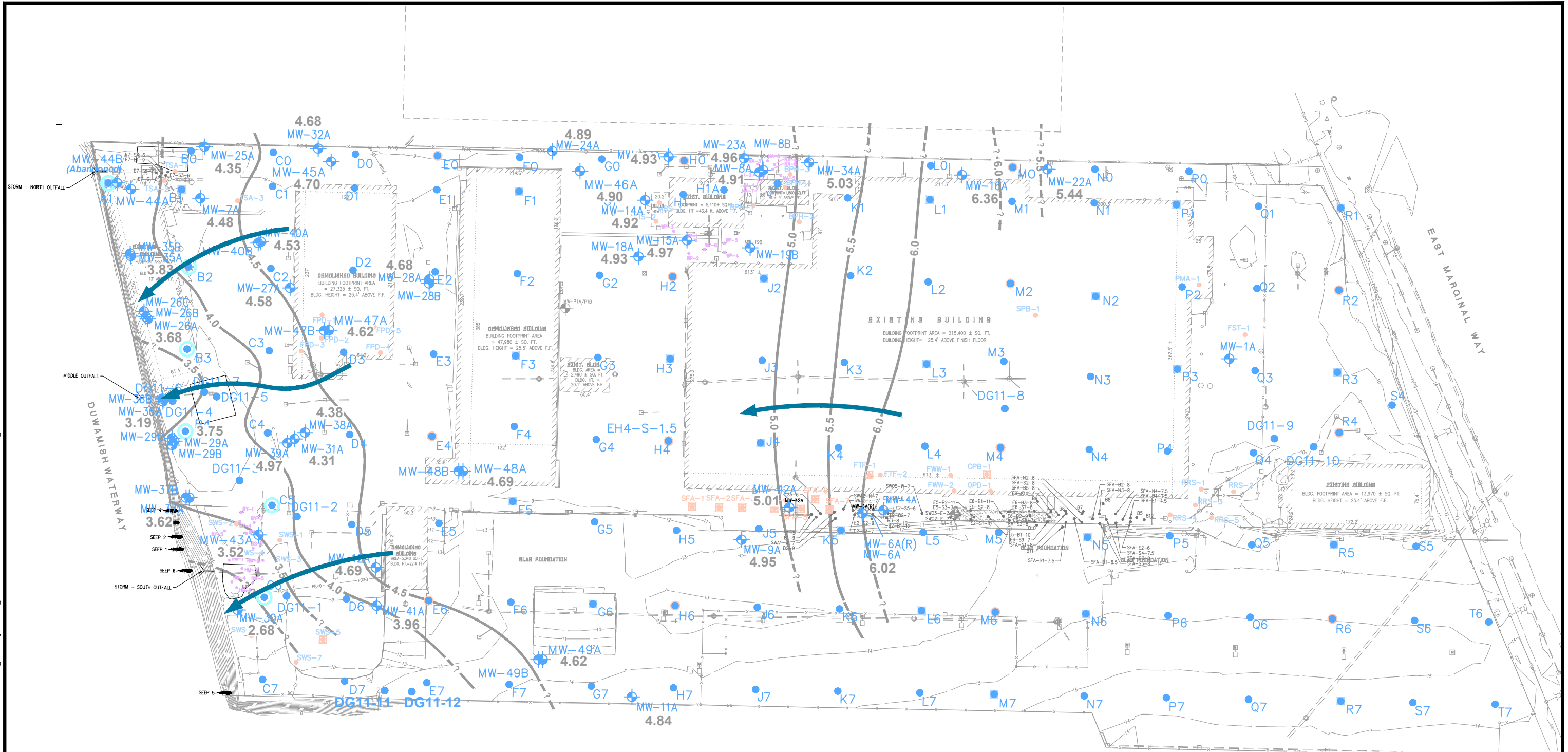

NOTES

1. Exploration locations are approximate.
2. Base map and historic exploration points are from Kennedy-Jenks Figures 2 and 3, 046001.00/Report/Po4SK003.
3. Groundwater data is from AMEC's Figure 3 "Groundwater Elevation September 27, 2011 (Low Tide), dated January 2012.
4. MW-39A is an outlier as adjacent to the air sparge/soil vapor extraction line and is not plotted.

SAMPLING LOCATIONS

- Soil Sample Location
- MW-36A ● Shallow Zone Groundwater Monitoring Well
- Previous Soil Boring Location
- - - Fenceline

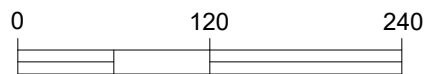

Scale in Feet
Contour Interval = 1 Foot
Datum = NGVD29

GROUNDWATER SYMBOLOGY

- - - Groundwater Elevation Contour, Dashed Where Approximate (Only A-Zone Well Data Used)
- 6.0 Groundwater Elevation in Feet (NAVD88)
- ← Approximate Groundwater Flow Direction

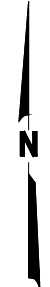

8801 East Marginal Way South Tukwila, Washington	
GROUNDWATER ELEVATION SEPTEMBER 27, 2011 (LOW TIDE)	
June 2019	21-1-12567-014
SHANNON & WILSON, INC. GEOTECHNICAL AND ENVIRONMENTAL CONSULTANTS	FIG. 4

BOEING THOMPSON PROPERTY

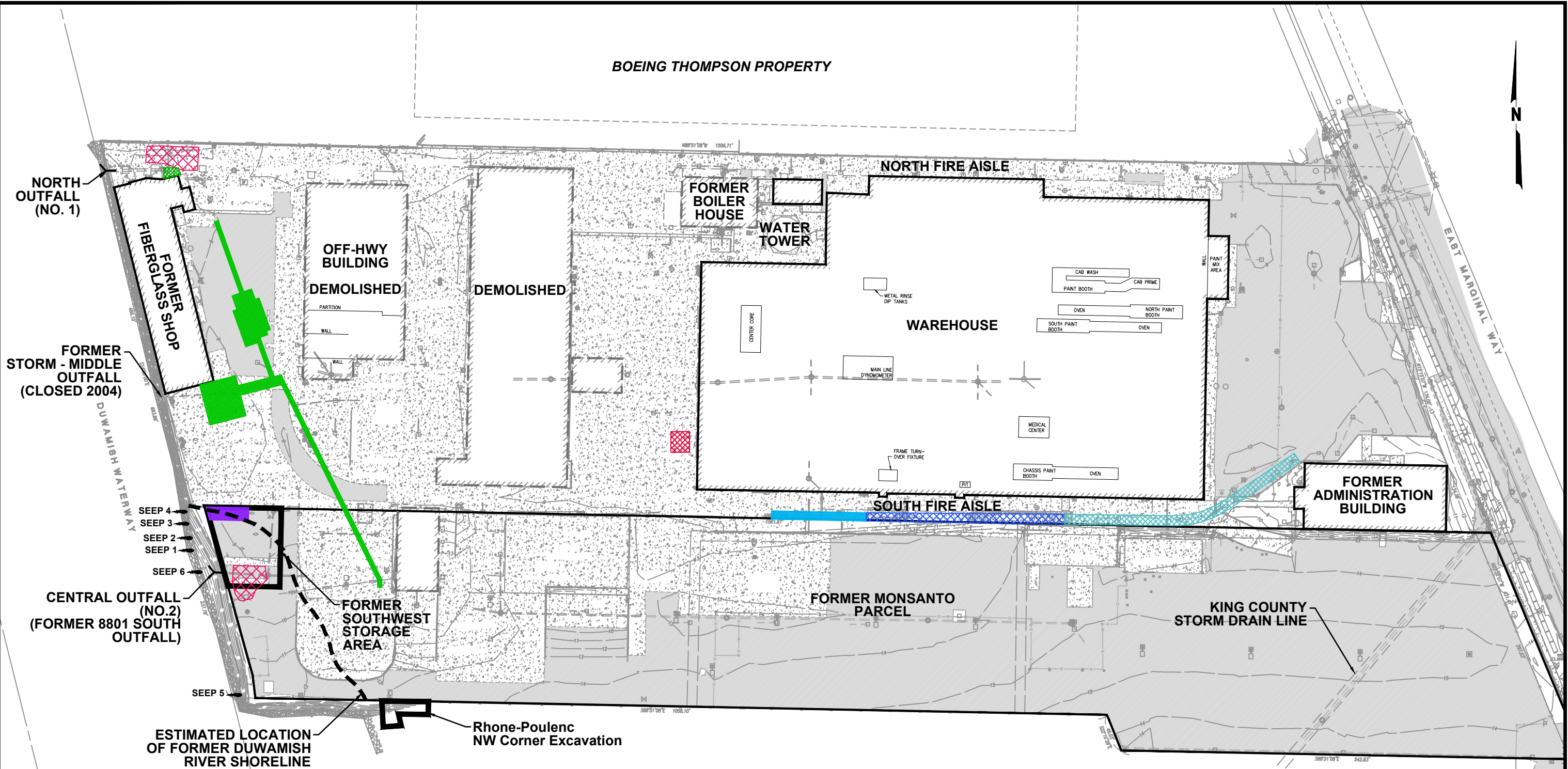

NORTH OUTFALL (NO. 1)

FORMER STORM - MIDDLE OUTFALL (CLOSED 2004)

SEEP 4
SEEP 3
SEEP 2
SEEP 1
SEEP 6

CENTRAL OUTFALL (NO.2) (FORMER 8801 SOUTH OUTFALL)

ESTIMATED LOCATION OF FORMER DUWAMISH RIVER SHORELINE

Rhone-Poulenc NW Corner Excavation

CONTAINER PROPERTIES LLC

(INSURANCE AUTO AUCTIONS INCORPORATED VEHICLE STORAGE ON BOTH 8801 AND CONTAINER PROPERTIES PARCELS)

MUSEUM OF FLIGHT

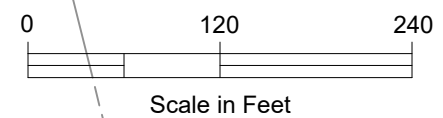

- LEGEND**
- Existing Buildings
 - Former Buildings
 - Southwest Storage Area Approximate Excavation Area (1995)

- Approximate UST Removal Excavation Area (2000-2003)
- Approximate Acetone UST Soil Excavation Area (2003)

- Approximate SFA Soil Excavation Area (2004)
- Approximate AS/SVE Soil Excavation Area (2004)

- Approximate Soil Excavation Area (2004)
- Approximate ORC Injection Area (2004)
- Approximate Stormwater Soil Excavation Area (2007)

NOTE
Figure adapted from AMEC 14995-L-32.dwg dated 05/2013, and 14995-L-16.dwg dated November 2010.

8801 East Marginal Way South Tukwila, Washington	
PREVIOUS EXCAVATION LOCATIONS	
June 2019	21-1-12567-014
SHANNON & WILSON INC. GEOTECHNICAL AND ENVIRONMENTAL CONSULTANTS	FIG. 5

Filename: \\sea-fs1\draffing\211\12567\014\21-1-12567-014 Key Site Features.dwg Layout: Figure 5-IAWP Date: 06-03-2019 Login: JRS

Filename: \\sea-fs1\Drafting\2111\2567\014\21-1-1-12567-014 Conceptual Site Model.dwg Layout: Figure 6-IAWP Date: 06-03-2019 Login: JRS

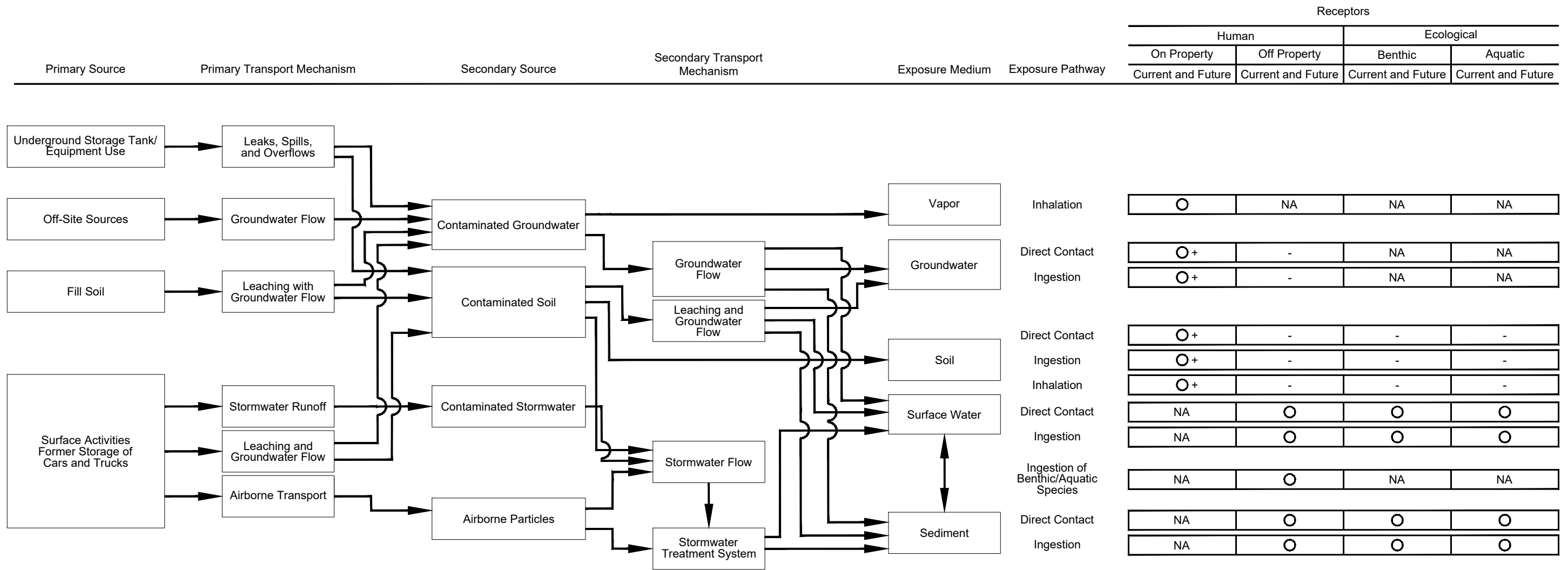

LEGEND
 ○ Complete Exposure Pathway
 - Incomplete Exposure Pathway
 NA Not Applicable
 + Construction Worker

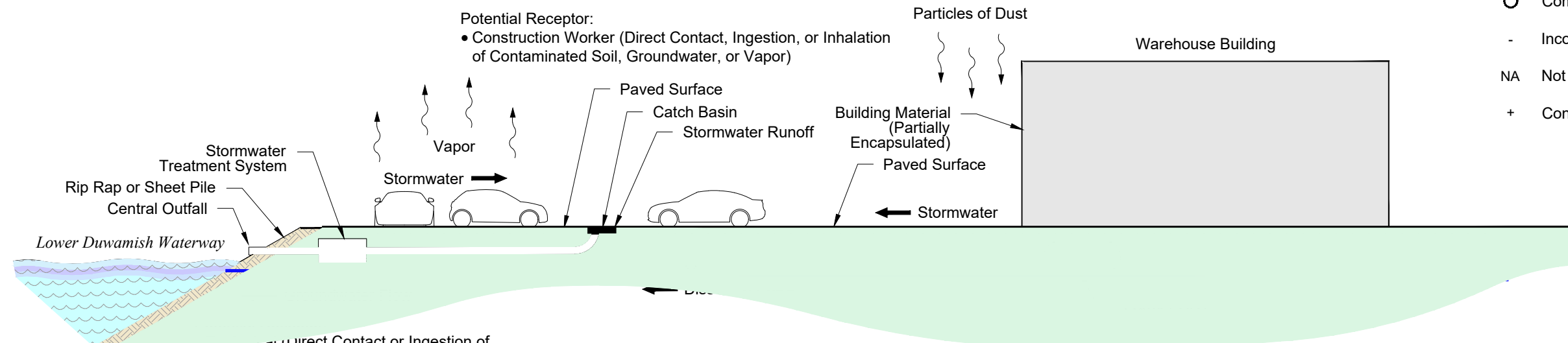

Potential Receptor:
 • Construction Worker (Direct Contact, Ingestion, or Inhalation of Contaminated Soil, Groundwater, or Vapor)
 • Ecological (Direct Contact or Ingestion of Contaminated Surface Water or Sediment)
 • Human (Direct Contact with Contaminated Surface Water or Sediment or Ingestion of Benthic/Aquatic Species)

8801 Site
 8801 East Marginal Way S
 Tukwila, Washington

CONCEPTUAL SITE MODEL

June 2019 21-1-12567-014

SHANNON & WILSON, INC.
GEOTECHNICAL AND ENVIRONMENTAL CONSULTANTS

FIG. 6

Filename: \\sea-fs1\Drafting\21112567\014\21-1-12567-014 DUA.dwg Layout: Figure 7-IAWP Date: 06-03-2019 Login: JRS

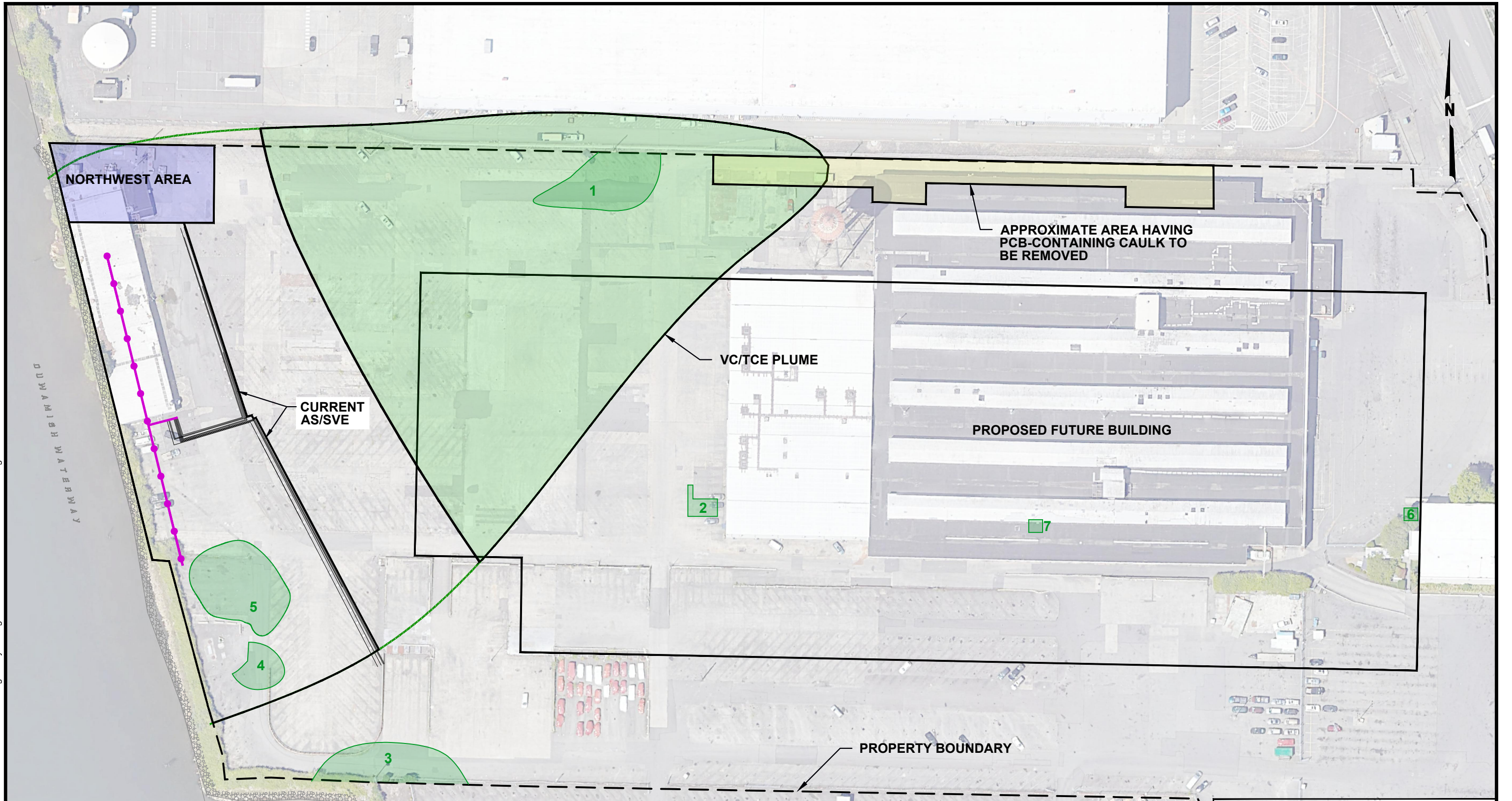

LEGEND

- 3 Soil Excavation Area
- Proposed Enhanced Reductive Dechlorination Groundwater Remediation Area
- Proposed In Situ Chemical Oxidation Groundwater Remediation Area
- Proposed Extension of Air Sparge/Soil Vapor Extraction Groundwater Remedy

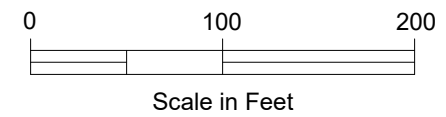

8801 East Marginal Way South
Tukwila, Washington

PROPOSED REMEDIATION

June 2019

21-1-12567-014

SHANNON & WILSON, INC.
PROFESSIONAL AND ENVIRONMENTAL CONSULTANTS

FIG. 7

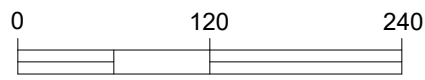
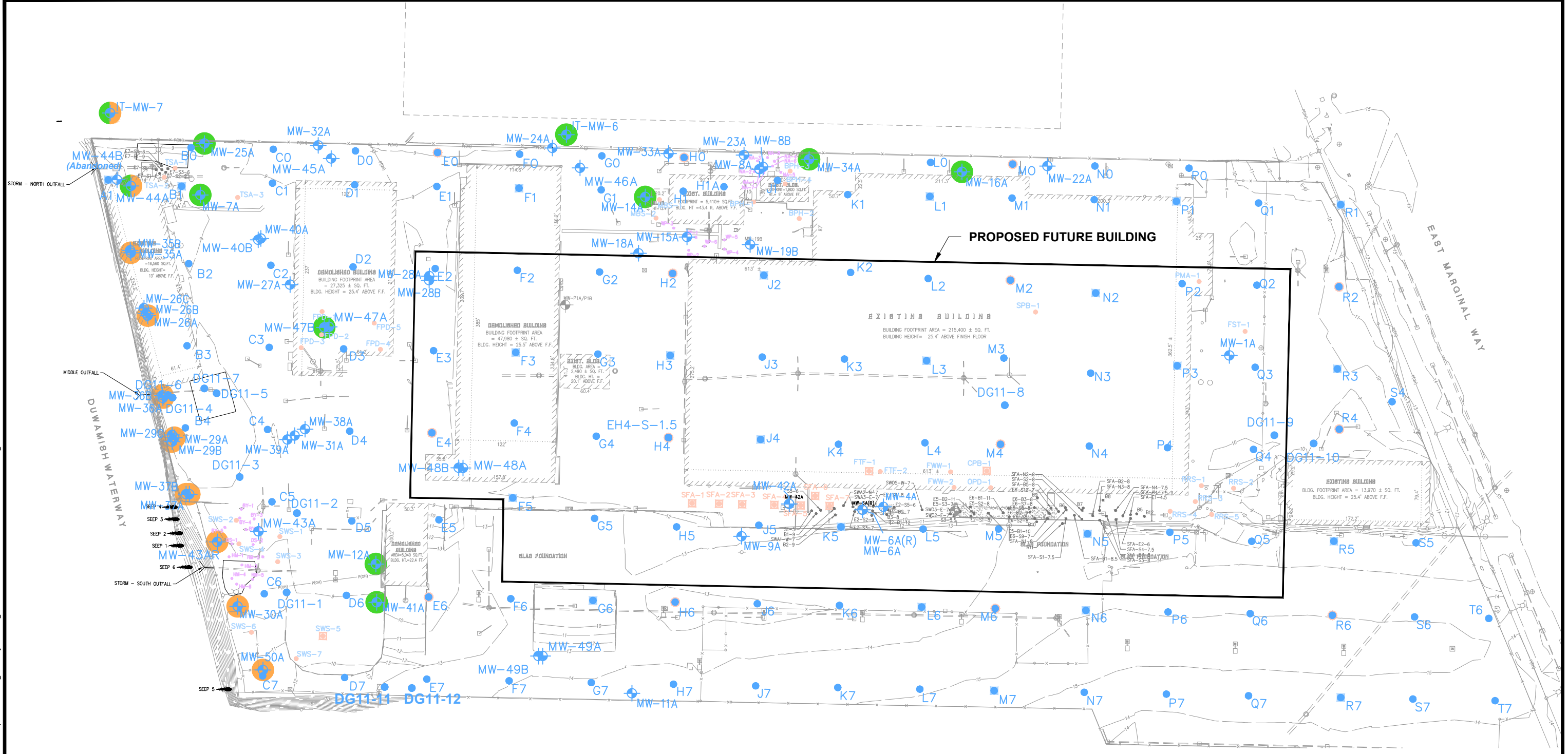

Scale in Feet
Contour Interval = 1 Foot
Datum = NGVD29

NOTES

- 1. Exploration locations are approximate.
- 2. Base map and historic exploration points are from Kennedy-Jenks Figures 2 and 3, 046001.00/Report/Po4SK003.

SAMPLING LOCATIONS

- Soil Sample Location
- MW-36A + Shallow Zone Groundwater Monitoring Well
- Previous Soil Boring Location
- - - - - Fenceline

SAMPLING CONFIRMATION

- Performance Wells
- Compliance Wells



8801 East Marginal Way South Tukwila, Washington	
PERFORMANCE AND COMPLIANCE MONITORING WELLS	
June 2019	21-1-12567-014
SHANNON & WILSON INC. <small>GEOTECHNICAL AND ENVIRONMENTAL CONSULTANTS</small>	FIG. 8

Filename: \\sea-fs1\Drafting\21112567014\21-1-12567-014 Compliance.dwg Layout: Figure 8-IAMP Date: 06-03-2019 Login: JRS

Appendix A

Chemical of Concern Distribution Figures

APPENDIX A: CHEMICAL OF CONCERN DISTRIBUTION FIGURES

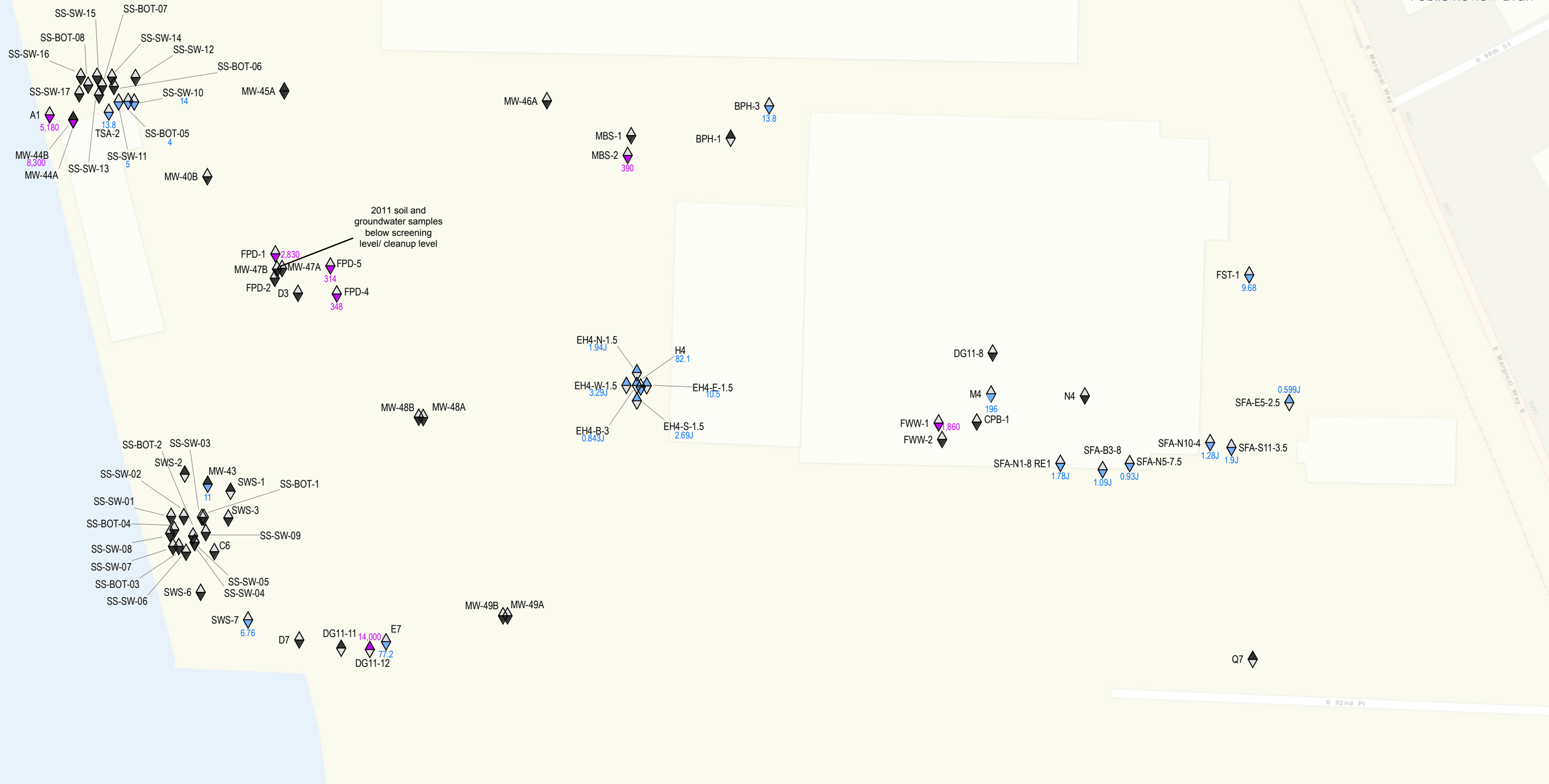

2011 soil and groundwater samples below screening level/ cleanup level

LEGEND

Sample Location
 Unsaturated Surface to 3 feet
 Saturated

- Not Analyzed
- Analyzed - Not Detected
- Analyzed - Detected At or Below Screening Level
- Analyzed - Not Detected and Detection Limit Greater Than Screening Level
- Analyzed - Detected Greater Than Screening Level

EXAMPLE

FPD-5
 314

*Sample Location is FPD-5.
 Sample analyzed and detected greater than screening level.
 Sample result is 314 mg/kg for Unsaturated.*

NOTE
 Screening against project proposed cleanup level.
 Gasoline-Range Hydrocarbons cleanup level in soil is 250 mg/kg.

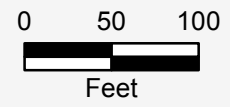

8801 East Marginal Way South
 Tukwila, Washington

**GASOLINE RANGE
 HYDROCARBONS IN SOIL**

June 2019

21-1-12567-014

SHANNON & WILSON, INC.
GEOTECHNICAL AND ENVIRONMENTAL CONSULTANTS

FIG. A-1

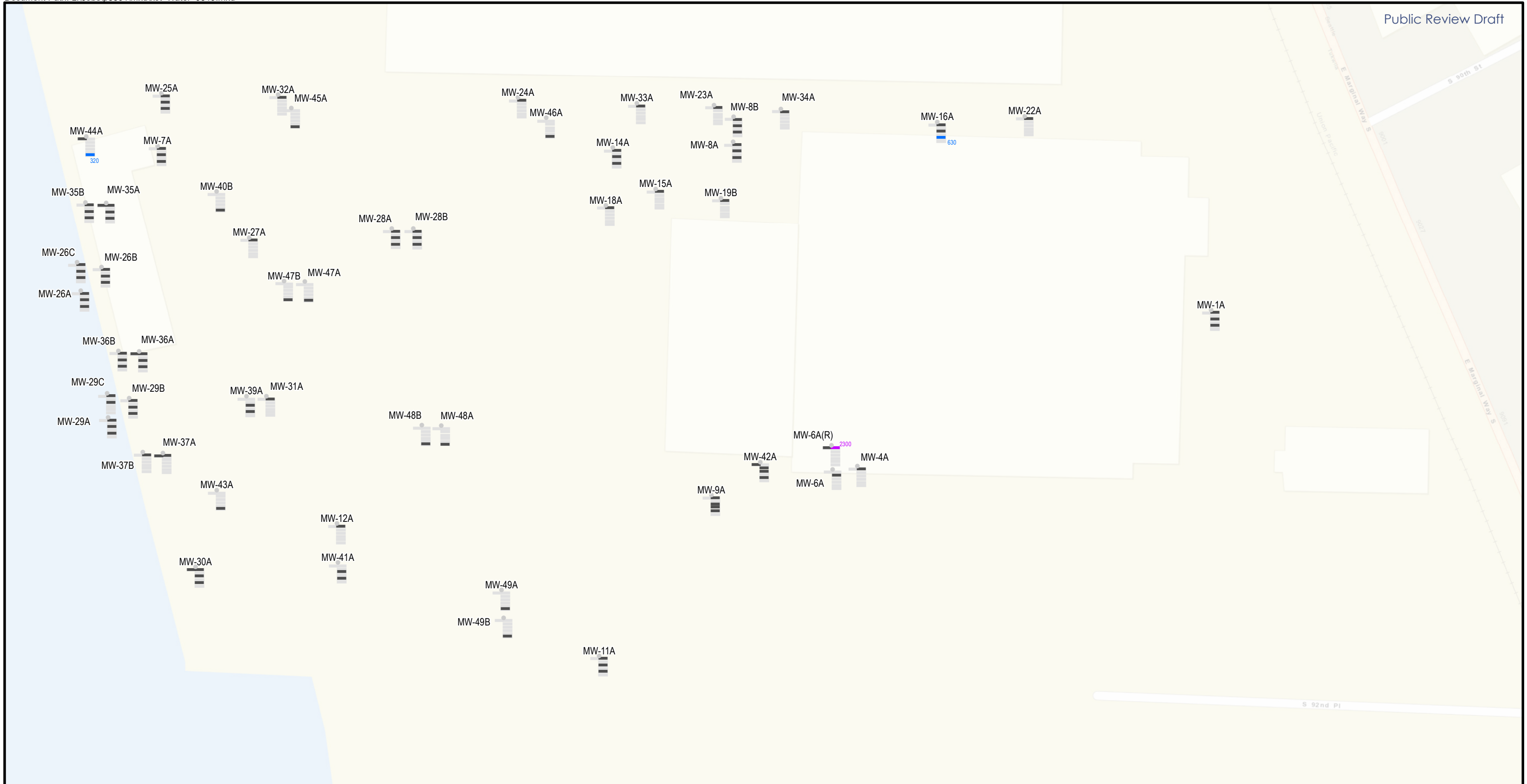

LEGEND

Sample Location

2019 - Winter	2002 - Spring
2004 - Spring	2006 - Spring
2006 - Spring*	2006 - Fall
2011 - Fall	

Sample - Date

- Not Analyzed
- Analyzed - Not Detected
- Analyzed - Detected At or Below Screening Level
- Analyzed - Not Detected and Detection Limit Greater Than Screening Level
- Analyzed - Detected Greater Than Screening Level

NOTE
 Screening against project proposed cleanup level.
 Gasoline range hydrocarbons cleanup level in groundwater is 1,000 ug/L.

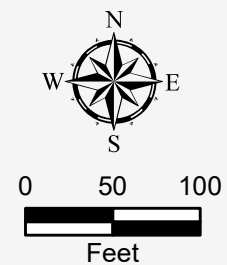

8801 East Marginal Way South
 Tukwila, Washington

**GASOLINE RANGE HYDROCARBONS
 IN GROUNDWATER**

June 2019 21-1-12567-014

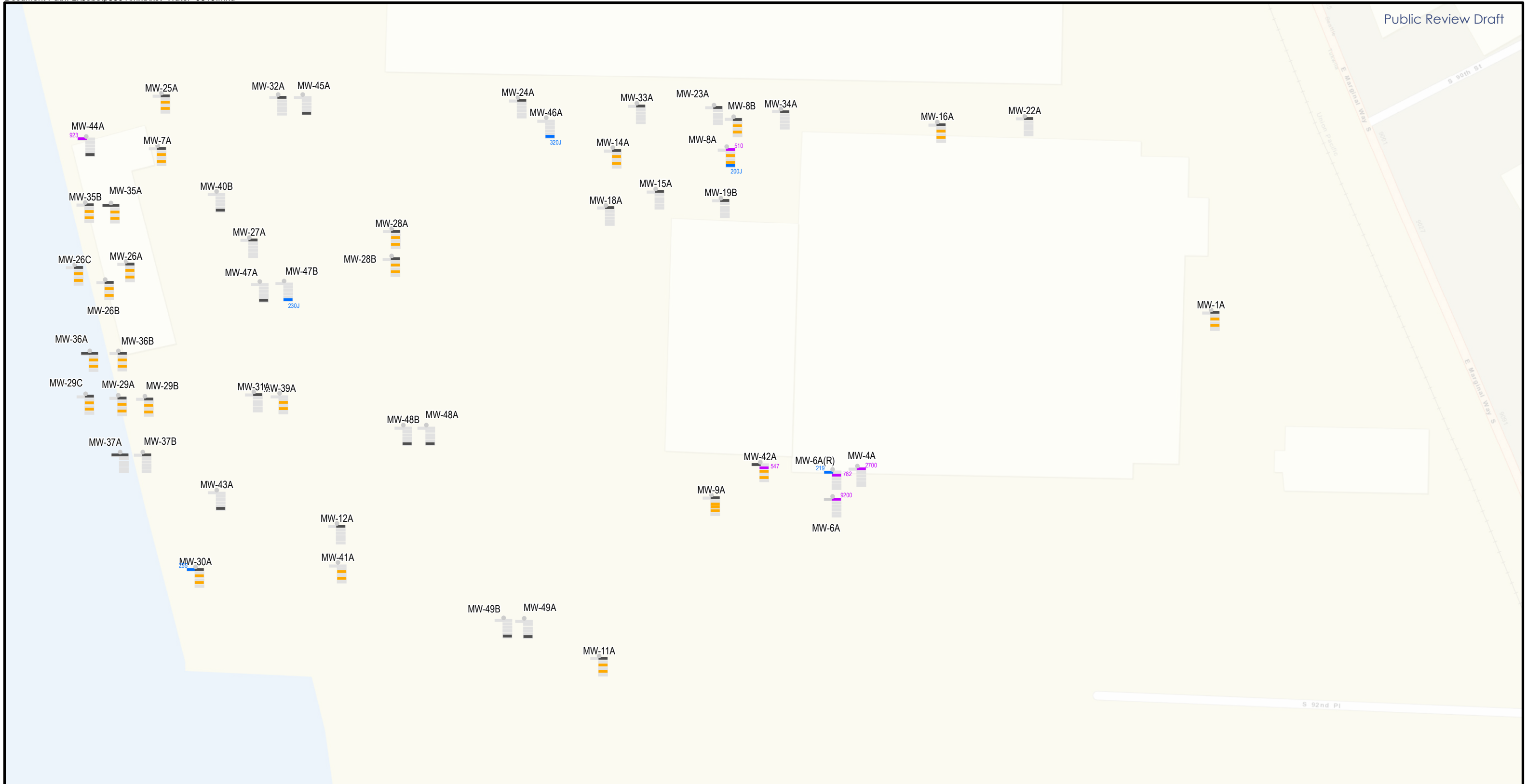

LEGEND

Sample Location

2019 - Winter	2002 - Spring
2004 - Spring	2004 - Spring
2006 - Spring	2006 - Spring *
2006 - Fall	2006 - Fall
2011 - Fall	2011 - Fall

Sample - Date

- Not Analyzed
- Analyzed - Not Detected
- Analyzed - Detected At or Below Screening Level
- Analyzed - Not Detected and Detection Limit Greater Than Screening Level
- Analyzed - Detected Greater Than Screening Level

NOTE
Screening against project proposed cleanup level. Diesel range hydrocarbons cleanup level in groundwater is 500 ug/L.

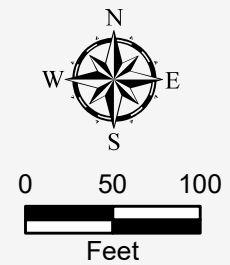

8801 East Marginal Way South
Tukwila, Washington

**DIESEL RANGE HYDROCARBONS
IN GROUNDWATER**

June 2019 21-1-12567-014

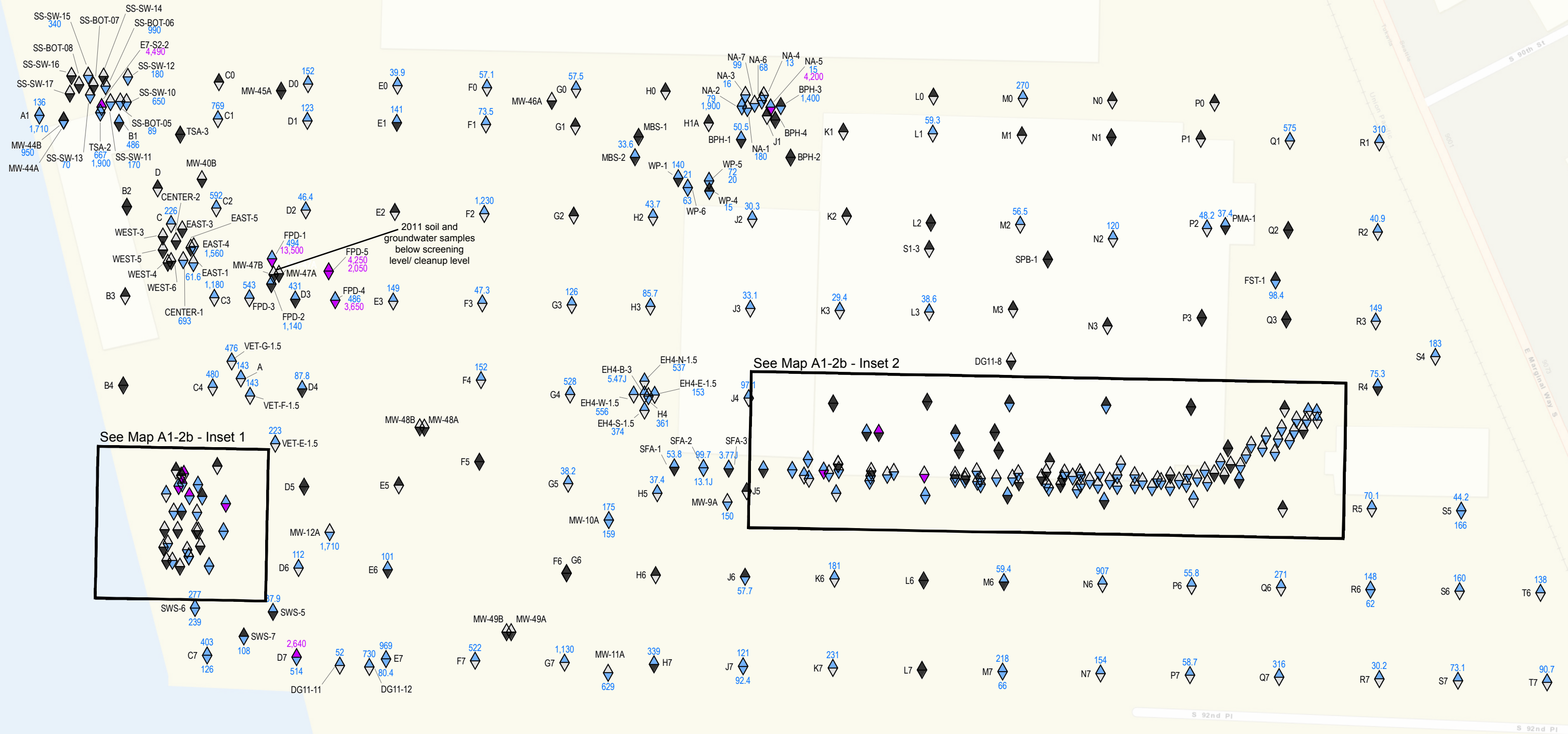

LEGEND

Sample Location

Unsaturated Surface to 3 feet
Saturated

- Not Analyzed
- Analyzed - Not Detected
- Analyzed - Detected At or Below Screening Level
- Analyzed - Not Detected and Detection Limit Greater Than Screening Level
- Analyzed - Detected Greater Than Screening Level

EXAMPLE

E7-S2-2



Sample Location is E7-S2-2.
Sample analyzed and detected greater than screening level.
Sample result is 4,490 mg/kg for Unsaturated.

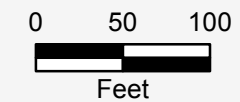

NOTE
Screening against project proposed cleanup level. Oil-Range Hydrocarbons cleanup level in soil is 2,000 mg/kg.

8801 East Marginal Way South
Tukwila, Washington

**OIL RANGE HYDROCARBONS
IN SOIL**

June 2019

21-1-12567-014

SHANNON & WILSON, INC.
GEOTECHNICAL AND ENVIRONMENTAL CONSULTANTS

FIG. A-4a

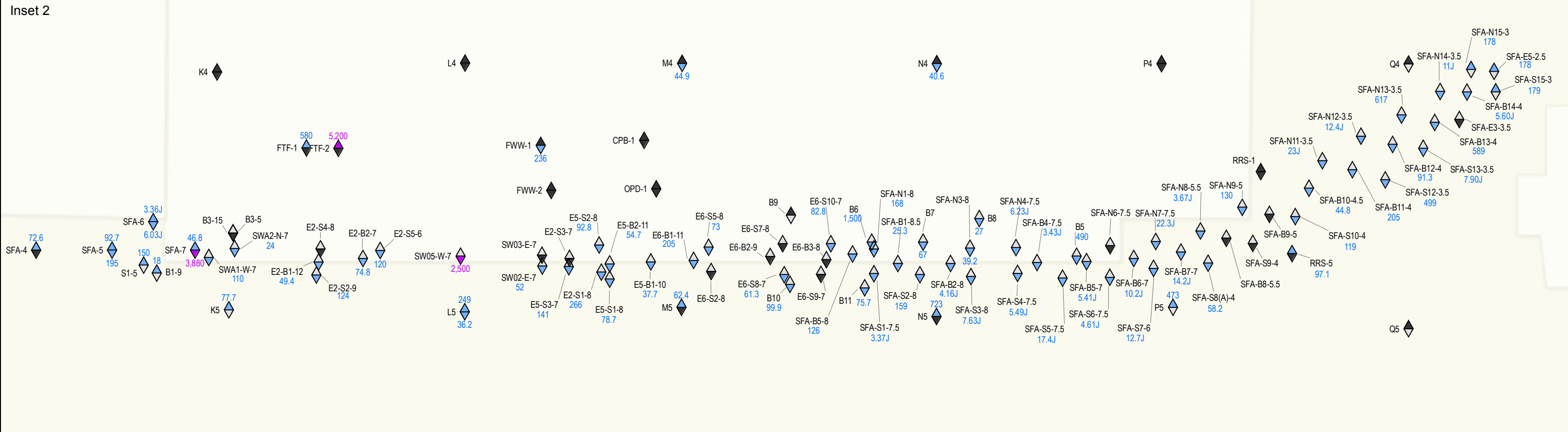
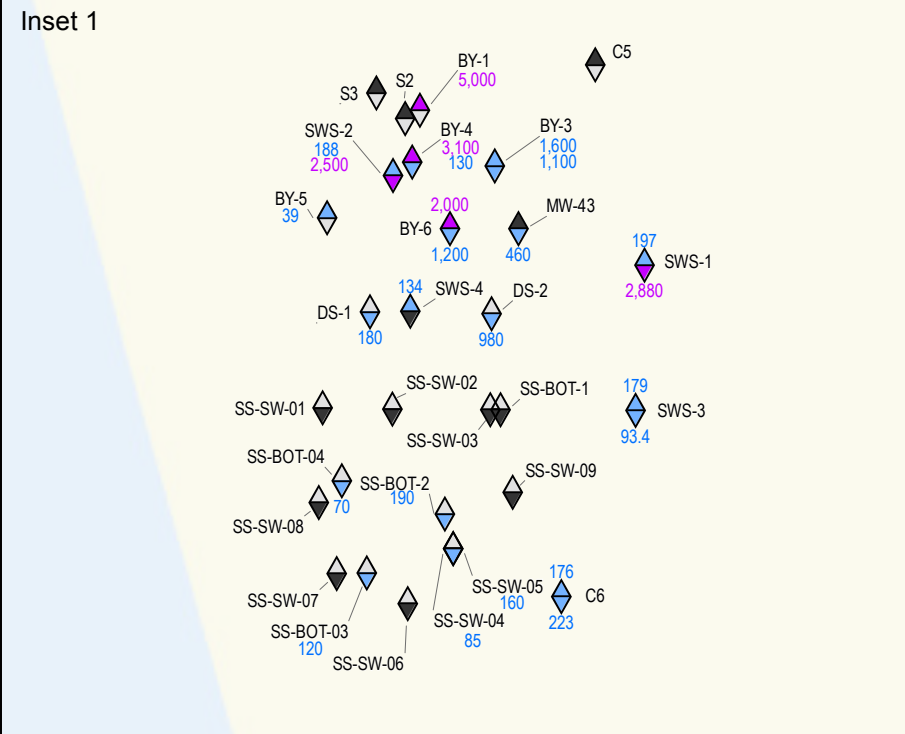

LEGEND

Sample Location
 Unsaturated Surface to 3 feet
 Saturated

- Not Analyzed
- Analyzed - Not Detected
- Analyzed - Detected At or Below Screening Level
- Analyzed - Not Detected and Detection Limit Greater Than Screening Level
- Analyzed - Detected Greater Than Screening Level

EXAMPLE
 BY-1

 Sample Location is BY-1.
 Sample analyzed and detected greater than screening level.
 Sample result is 5,000 mg/kg for Unsaturated.

NOTE
 Screening against project proposed cleanup level. Oil-Range Hydrocarbons cleanup level in soil is 2,000 mg/kg.

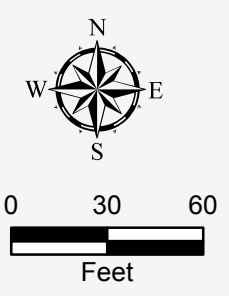

8801 East Marginal Way South
 Tukwila, Washington

**OIL RANGE HYDROCARBON
 IN SOIL**

June 2019 21-1-12567-014

SHANNON & WILSON, INC.
GEOTECHNICAL AND ENVIRONMENTAL CONSULTANTS

FIG. A-4b

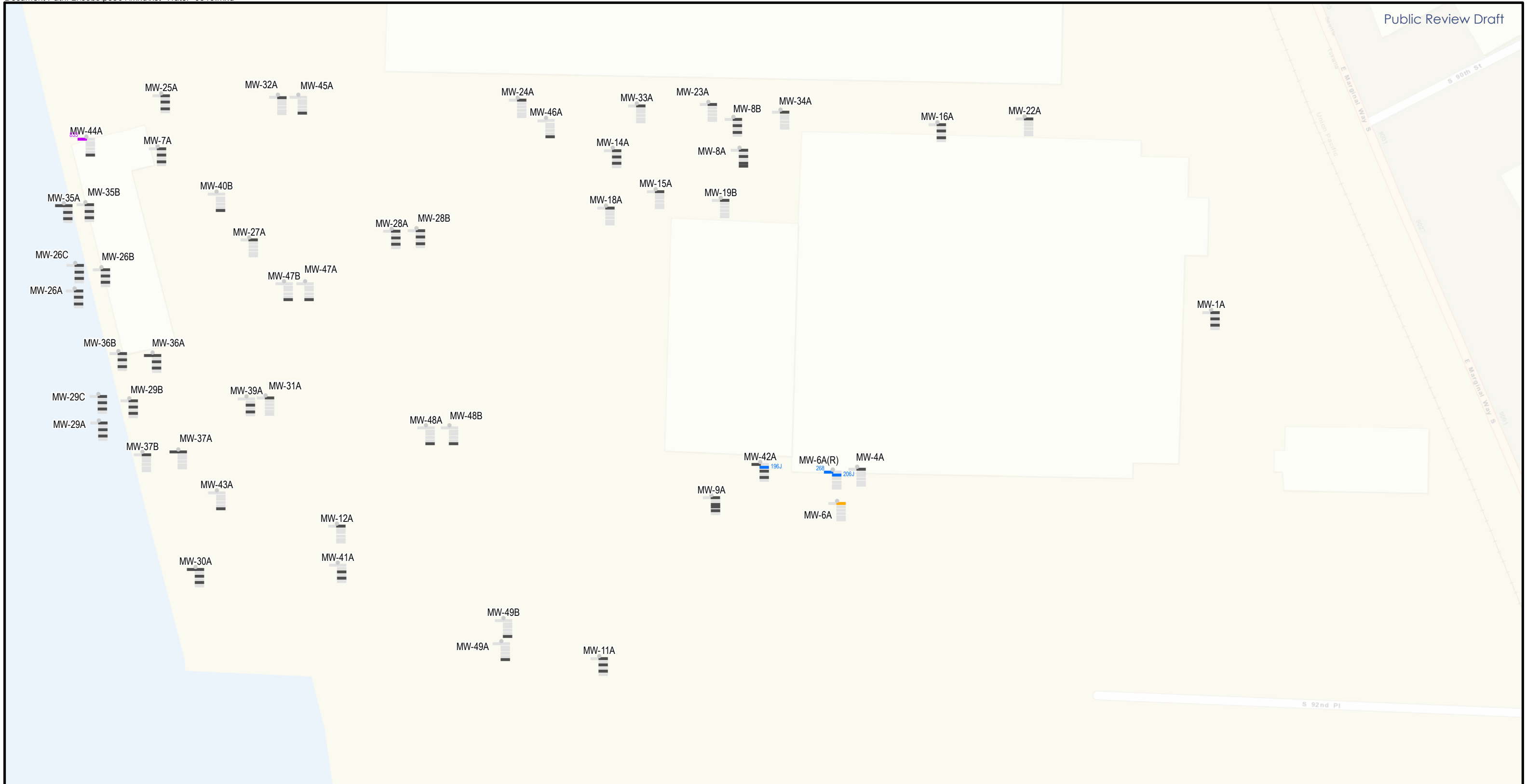

LEGEND

Sample Location

2019- Winter
2002 - Spring
2004 - Spring
2006- Spring
2006- Spring *
2006- Fall
2011- Fall

Sample - Date

- Not Analyzed
- Analyzed - Not Detected
- Analyzed - Detected At or Below Screening Level
- Analyzed - Not Detected and Detection Limit Greater Than Screening Level
- Analyzed - Detected Greater Than Screening Level

NOTE
Screening against project proposed cleanup level. Oil range hydrocarbons cleanup level in groundwater is 500 ug/L.

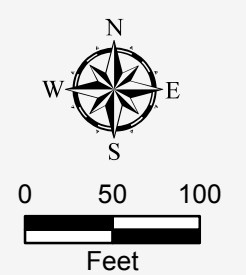

8801 East Marginal Way South
Tukwila, Washington

**OIL RANGE HYDROCARBONS
IN GROUNDWATER**

June 2019 21-1-12567-014

SHANNON & WILSON, INC.
GEOTECHNICAL AND ENVIRONMENTAL CONSULTANTS

FIG. A-5

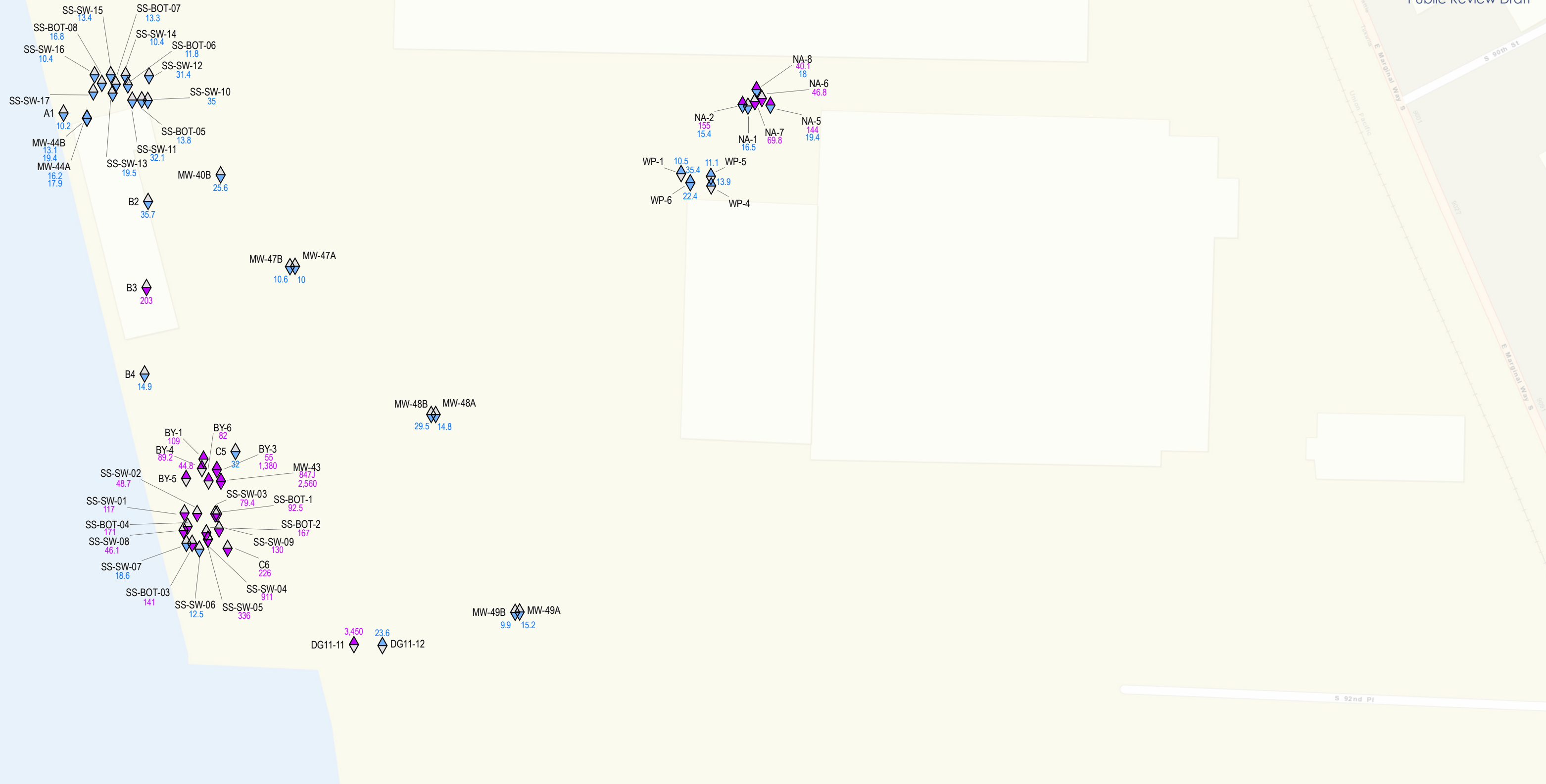

LEGEND

- Sample Location**
- Unsaturated Surface to 3 feet
 - Saturated Surface to 3 feet
 - Not Analyzed
 - Analyzed - Not Detected
 - Analyzed - Detected At or Below Screening Level
 - Analyzed - Not Detected and Detection Limit Greater Than Screening Level
 - Analyzed - Detected Greater Than Screening Level

EXAMPLE

B3

203

Sample Location is B3.
Sample analyzed and detected greater than screening level.
Sample result is 203 mg/kg for Saturated.

NOTE
Screening against project proposed cleanup level.
Copper cleanup level in soil is 36 mg/kg.

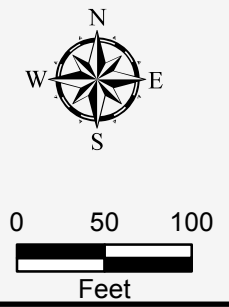

8801 East Marginal Way South
Tukwila, Washington

**COPPER
IN SOIL**

June 2019 21-1-12567-014

SHANNON & WILSON, INC.
GEOTECHNICAL AND ENVIRONMENTAL CONSULTANTS

FIG. A-6



LEGEND

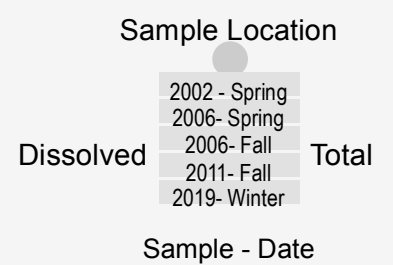

- Not Analyzed
- Analyzed - Not Detected
- Analyzed - Detected At or Below Screening Level
- Analyzed - Not Detected and Detection Limit Greater Than Screening Level
- Analyzed - Detected Greater Than Screening Level

NOTE
Screening against project proposed cleanup level. Copper cleanup level in groundwater is 8 ug/L.

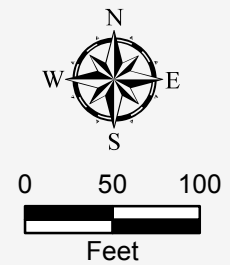

8801 East Marginal Way South
Tukwila, Washington

**COPPER
IN GROUNDWATER**

June 2019 21-1-12567-014

SHANNON & WILSON, INC.
GEOTECHNICAL AND ENVIRONMENTAL CONSULTANTS

FIG. A-7

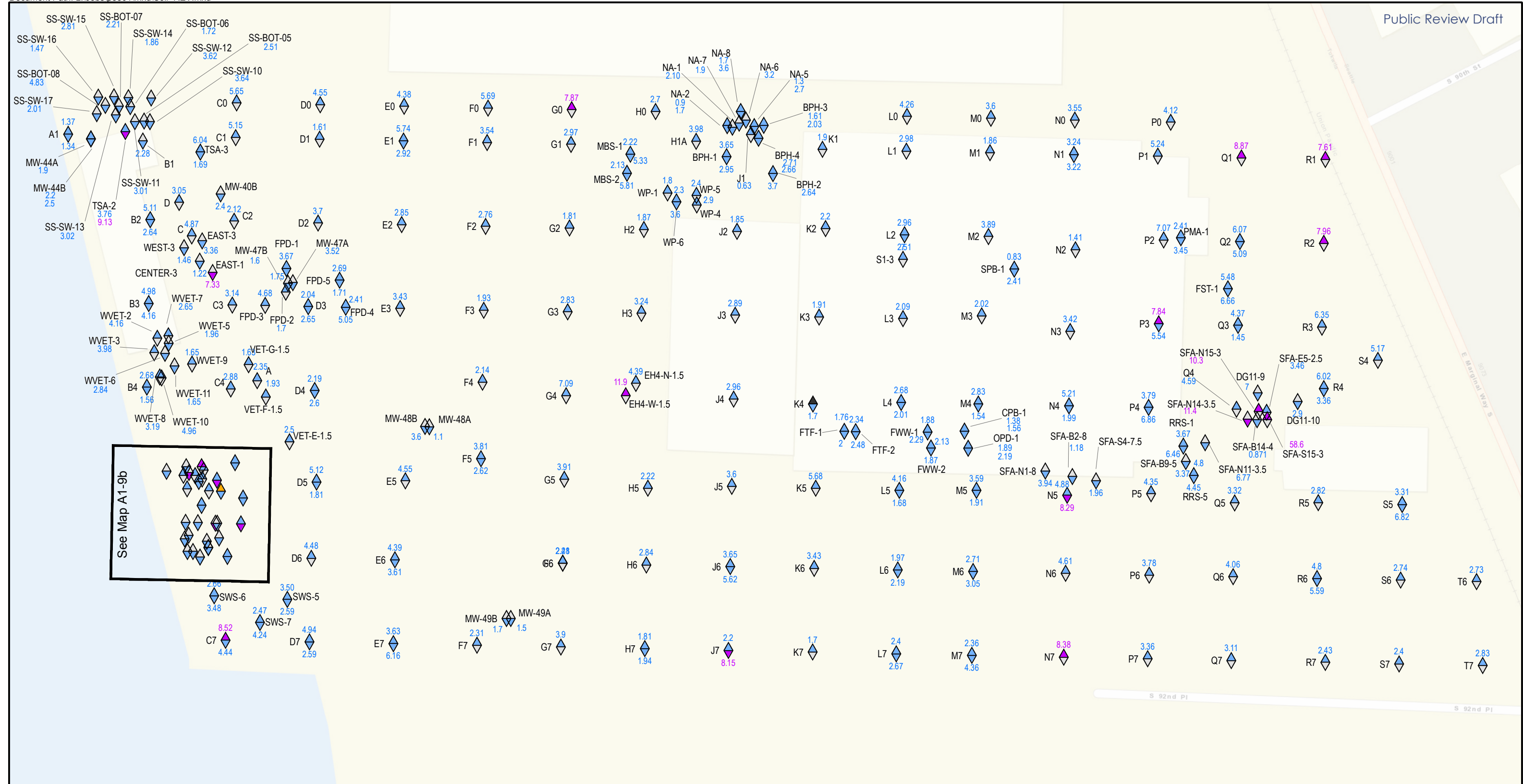

LEGEND

Sample Location

Unsaturated Surface to 3 feet
Saturated

- Not Analyzed
- Analyzed - Not Detected
- Analyzed - Detected At or Below Screening Level
- Analyzed - Not Detected and Detection Limit Greater Than Screening Level
- Analyzed - Detected Greater Than Screening Level

EXAMPLE



Sample Location is G0.
Sample analyzed and detected greater than screening level.
Sample result is 7.87 mg/kg for Unsaturated.

NOTE
Screening against project proposed cleanup level.
Arsenic cleanup level in soil is 7.3 mg/kg.

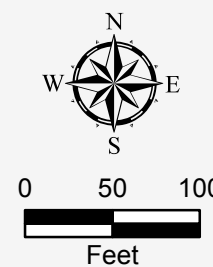

8801 East Marginal Way South
Tukwila, Washington

ARSENIC IN SOIL

June 2019

21-1-12567-014

SHANNON & WILSON, INC.
GEOTECHNICAL AND ENVIRONMENTAL CONSULTANTS

FIG. A-8a

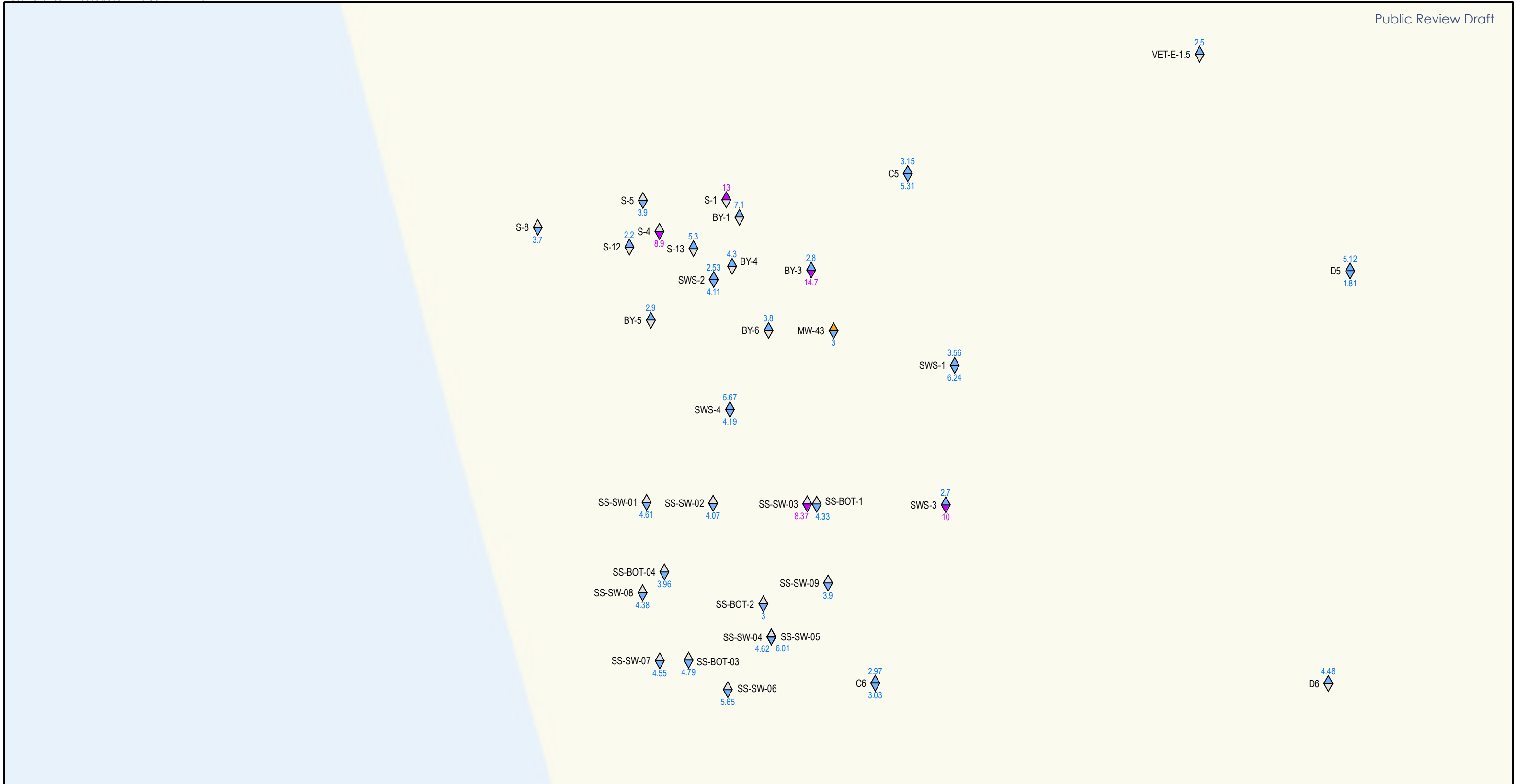

LEGEND

Sample Location
 Unsaturated Surface to 3 feet
 Saturated

- Not Analyzed
- Analyzed - Not Detected
- Analyzed - Detected At or Below Screening Level
- Analyzed - Not Detected and Detection Limit Greater Than Screening Level
- Analyzed - Detected Greater Than Screening Level

EXAMPLE



Sample Location is S-1.
 Sample analyzed and detected greater than screening level.
 Sample result is 13 mg/kg for Unsaturated.

NOTE
 Screening against project proposed cleanup level.
 Arsenic cleanup level in soil is 7.3 mg/kg.

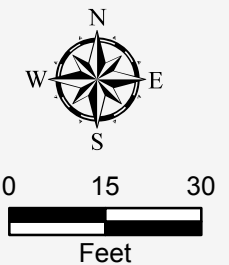

8801 East Marginal Way South
 Tukwila, Washington

ARSENIC IN SOIL

June 2019 21-1-12567-014

SHANNON & WILSON, INC.
GEOTECHNICAL AND ENVIRONMENTAL CONSULTANTS



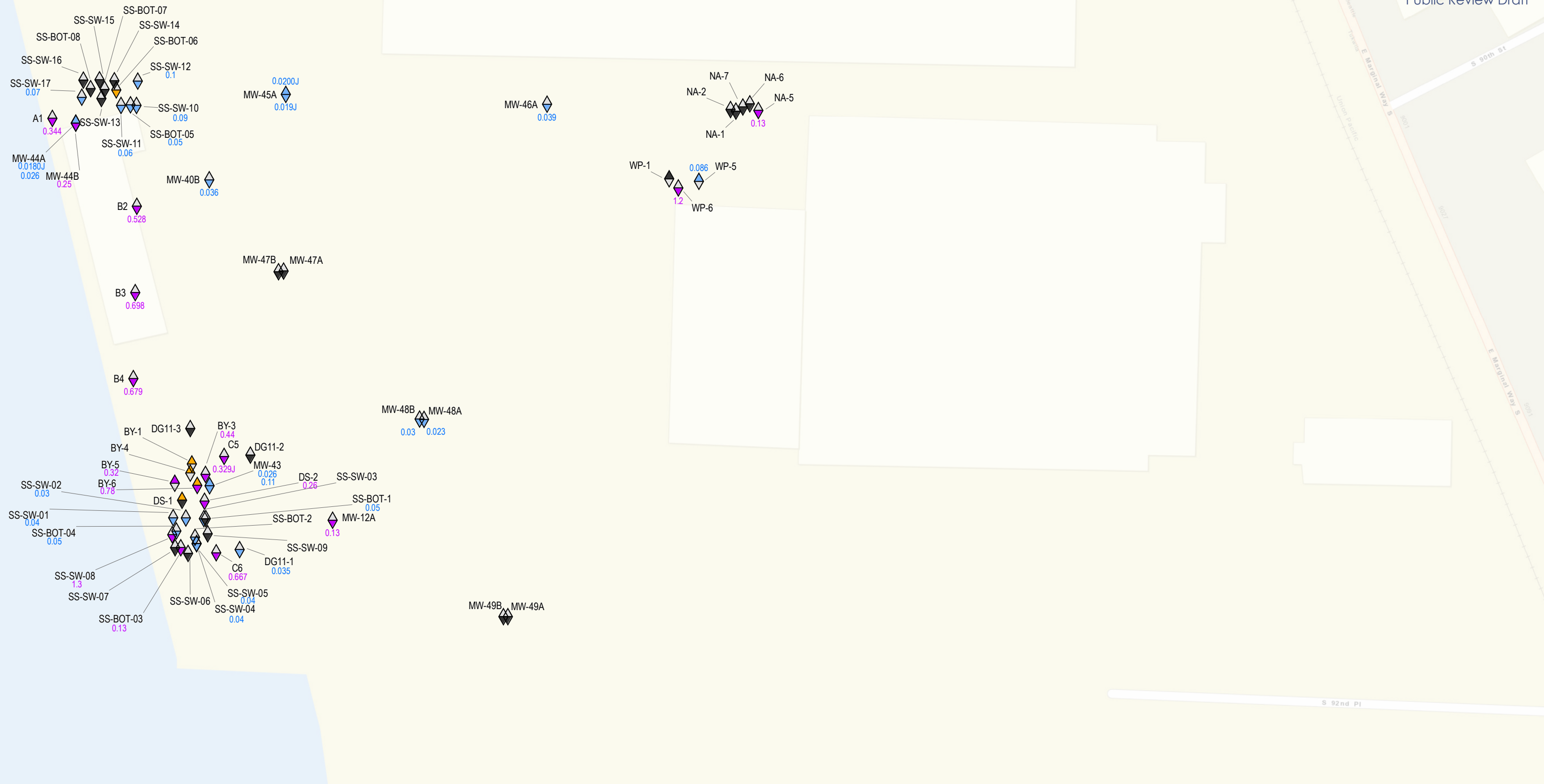

FIG. A-8b



LEGEND

Sample Location

Unsaturated  Surface to 3 feet
 Saturated 

-  Not Analyzed
-  Analyzed - Not Detected
-  Analyzed - Detected At or Below Screening Level
-  Analyzed - Not Detected and Detection Limit Greater Than Screening Level
-  Analyzed - Detected Greater Than Screening Level

EXAMPLE

BY-5  0.32

Sample Location is BY-5.
 Sample analyzed and detected greater than screening level.
 Sample result is 0.32 mg/kg for Unsaturated.

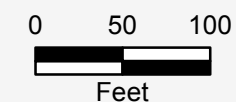

8801 East Marginal Way South
 Tukwila, Washington

**BIS(2-ETHYLHEXYL) PHTHALATE
 IN SOIL**

June 2019

21-1-12567-014

SHANNON & WILSON, INC.
 GEOTECHNICAL AND ENVIRONMENTAL CONSULTANTS

FIG. A-9

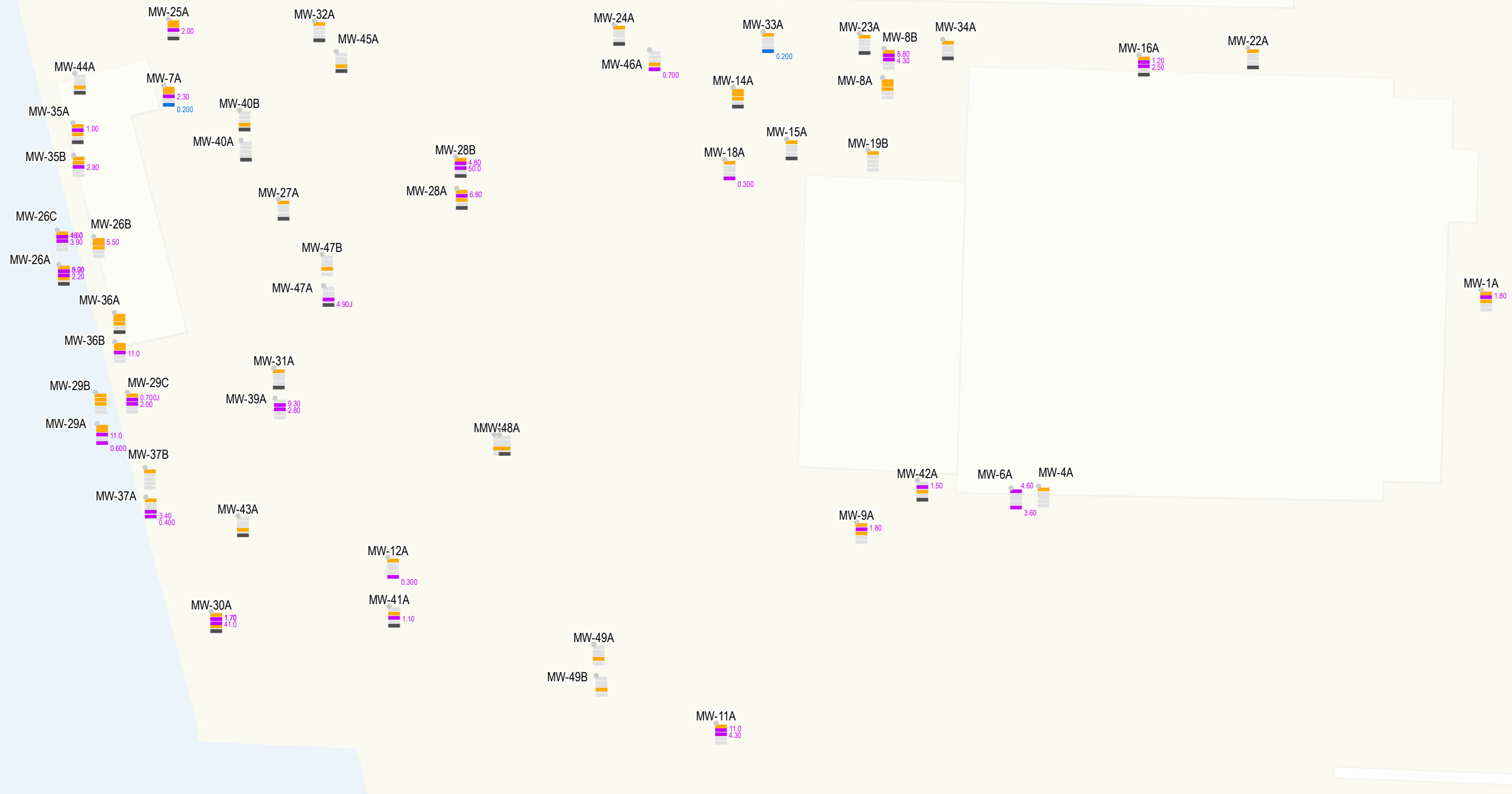

LEGEND

Sample Location

- 2002 - Spring
- 2004 - Spring
- 2006 - Spring
- 2006 - Fall
- 2011 - Fall
- 2019 - Winter

Sample - Date

- Not Analyzed
- Analyzed - Not Detected
- Analyzed - Detected At or Below Screening Level
- Analyzed - Not Detected and Detection Limit Greater Than Screening Level
- Analyzed - Detected Greater Than Screening Level

NOTE
Screening against project proposed cleanup level.
Bis(2-ethylhexyl) Phthalate cleanup level
in groundwater is 0.2 ug/L.

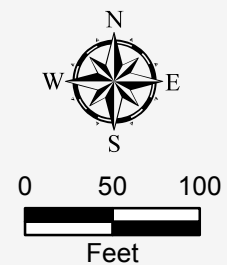

8801 East Marginal Way South
Tukwila, Washington

**BIS(2-ETHYLHEXYL) PHTHALATE
IN GROUNDWATER**

June 2019

21-1-12567-014

SHANNON & WILSON, INC.
GEOTECHNICAL AND ENVIRONMENTAL CONSULTANTS

FIG. A-10

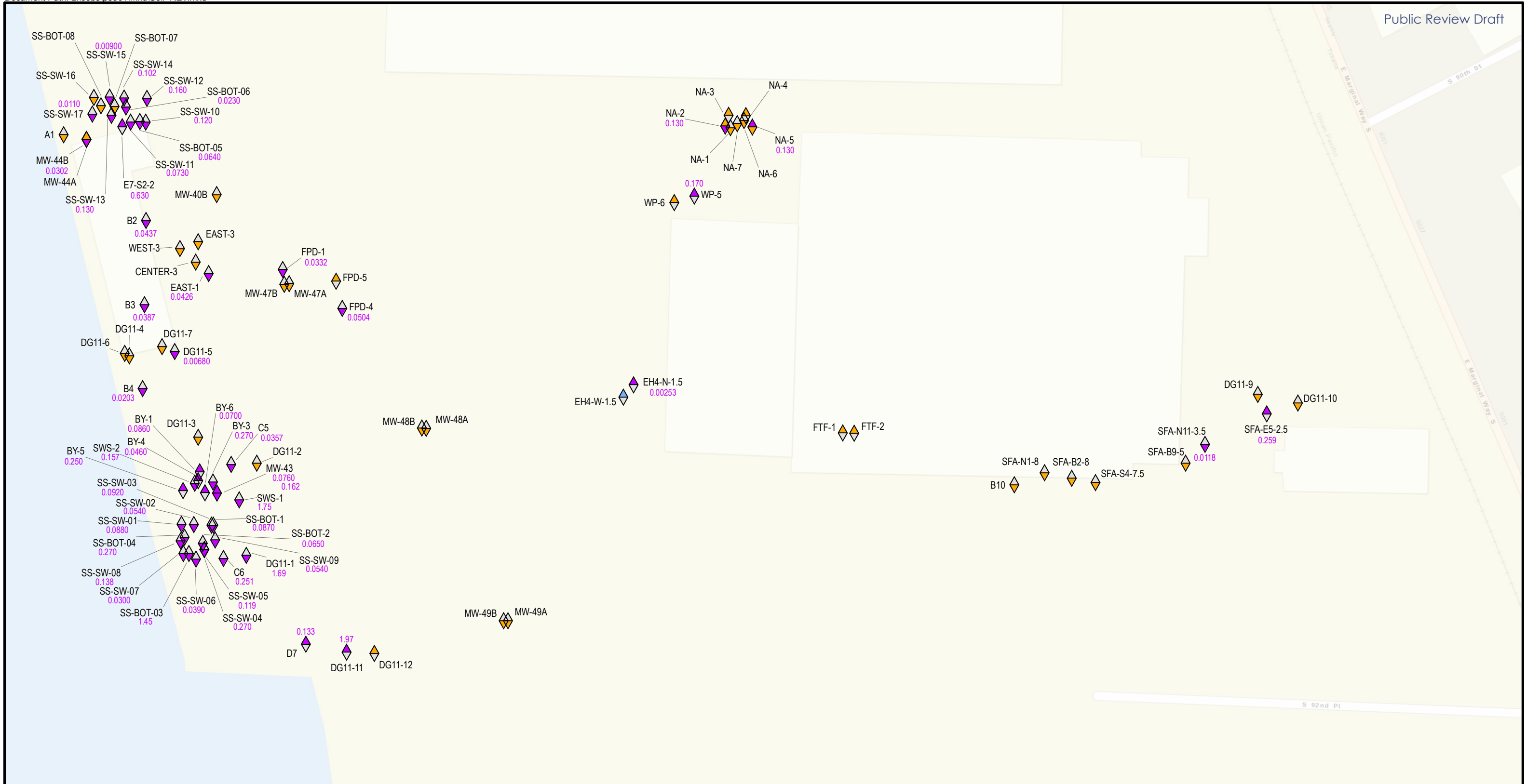

LEGEND

Sample Location

Unsaturated Surface to 3 feet
Saturated

- Not Analyzed
- Analyzed - Not Detected
- Analyzed - Detected At or Below Screening Level
- Analyzed - Not Detected and Detection Limit Greater Than Screening Level
- Analyzed - Detected Greater Than Screening Level

EXAMPLE

EH4-N-1.5
 0.00253

*Sample Location is EH4-N-1.5.
Sample analyzed and detected greater than screening level.
Sample result is 0.00253 mg/kg for Unsaturated.*

NOTE

Screening against project proposed cleanup level.
Total PCB aroclors cleanup level in soil is 0.002 mg/kg.

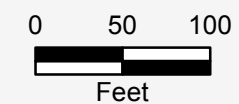
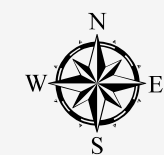

8801 East Marginal Way South
Tukwila, Washington

**TOTAL PCB AROCLORS
IN SOIL**

June 2019

21-1-12567-014

SHANNON & WILSON, INC.
GEOTECHNICAL AND ENVIRONMENTAL CONSULTANTS

FIG. A-11

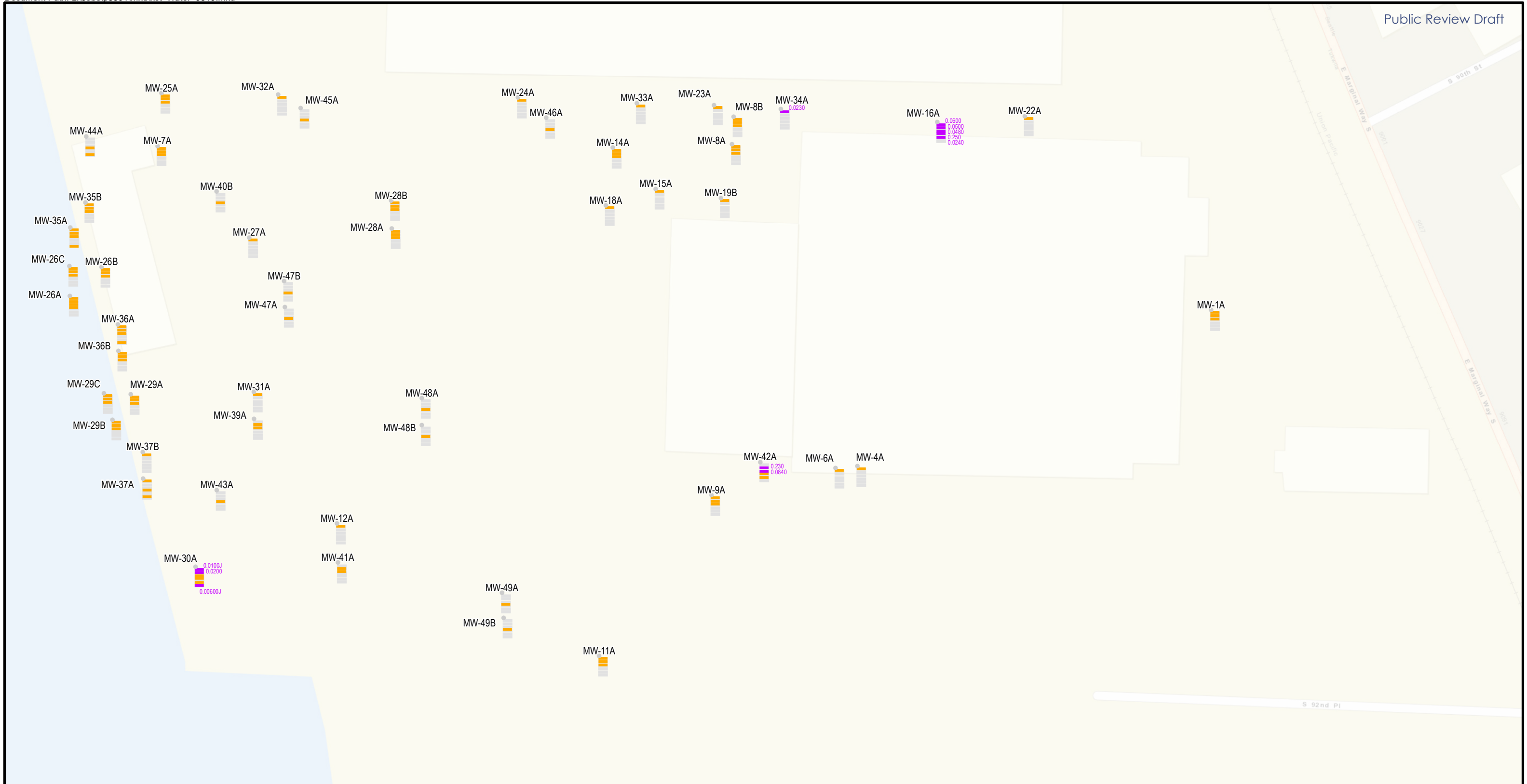

LEGEND

Sample Location

- 2002 - Spring
- 2004 - Spring
- 2006 - Spring
- 2006 - Fall
- 2011 - Fall
- 2019 - Winter

Sample - Date

- Not Analyzed
- Analyzed - Not Detected
- Analyzed - Detected At or Below Screening Level
- Analyzed - Not Detected and Detection Limit Greater Than Screening Level
- Analyzed - Detected Greater Than Screening Level

NOTE
 Screening against project proposed cleanup level. Total PCB aroclors in groundwater is 0.001 ug/L.

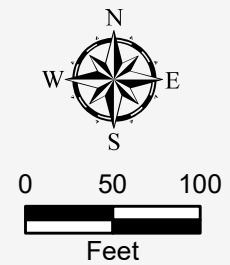

8801 East Marginal Way South
 Tukwila, Washington

**TOTAL PCB AROCLORS
 IN GROUNDWATER**

June 2019 21-1-12567-014

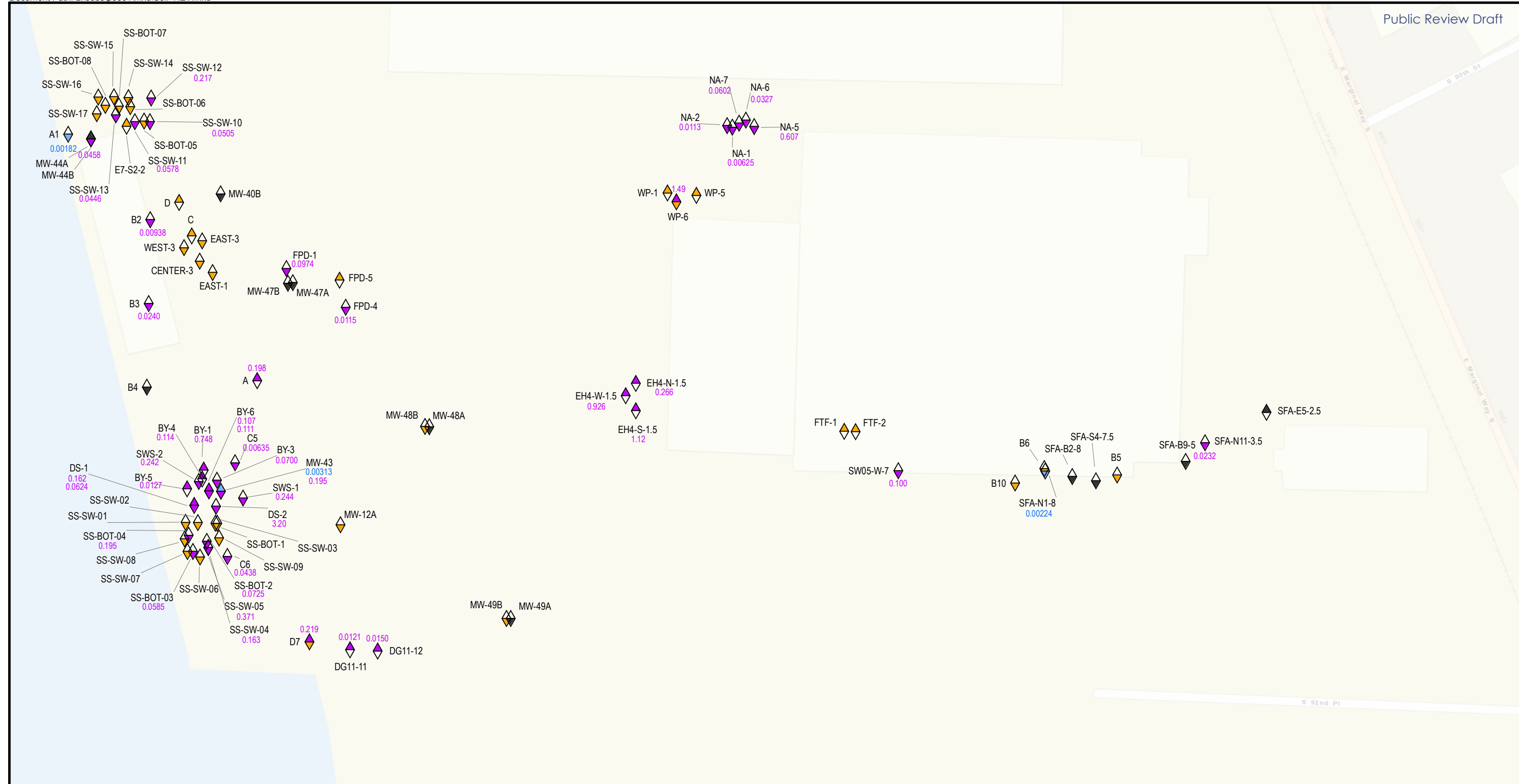

LEGEND

Sample Location

Unsaturated Surface to 3 feet
Saturated

- Not Analyzed
- Analyzed - Not Detected
- Analyzed - Detected At or Below Screening Level
- Analyzed - Not Detected and Detection Limit Greater Than Screening Level
- Analyzed - Detected Greater Than Screening Level

EXAMPLE

MW-43
 0.00313

*Sample Location is MW-43.
Sample analyzed and detected greater than screening level.
Sample result is 0.00313 mg/kg for Unsaturated.*

NOTE
Screening against project proposed cleanup level.
Total CPAH TEQ cleanup level in soil is 0.005 mg/kg.

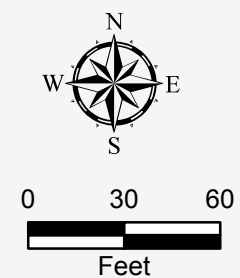

8801 East Marginal Way South
Tukwila, Washington

**TOTAL CPAH TEQ
IN SOIL**

June 2019

21-1-12567-014

SHANNON & WILSON, INC.
GEOTECHNICAL AND ENVIRONMENTAL CONSULTANTS

FIG. A-13

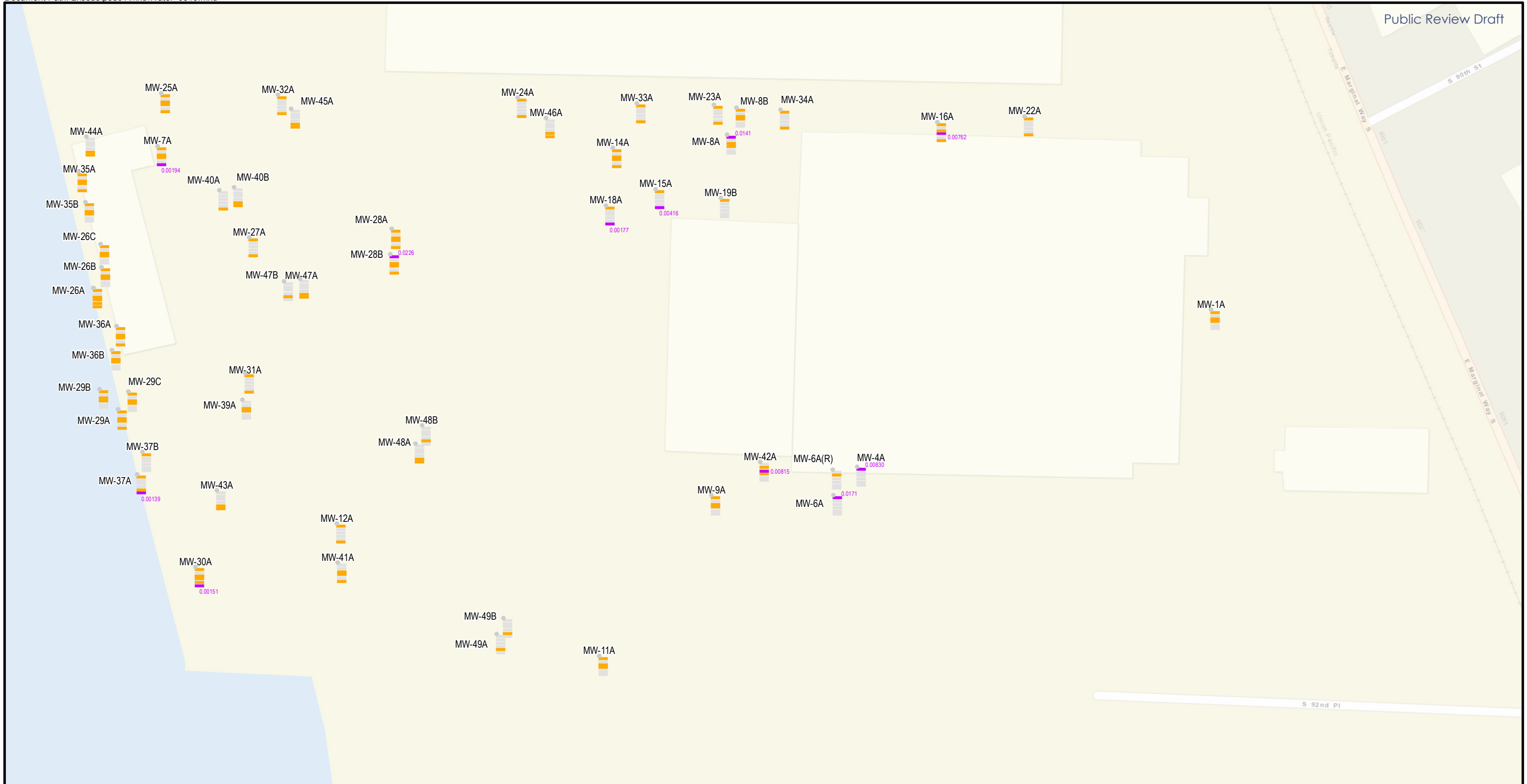

LEGEND

Sample Location

- 2002 - Spring
- 2004 - Spring
- 2006 - Spring
- 2006 - Fall
- 2011 - Fall
- 2019 - Winter

Sample - Date

- Not Analyzed
- Analyzed - Not Detected
- Analyzed - Detected At or Below Screening Level
- Analyzed - Not Detected and Detection Limit Greater Than Screening Level
- Analyzed - Detected Greater Than Screening Level

NOTE
 Screening against project proposed cleanup level.
 Total cPAH TEQ cleanup level in groundwater is 0.001 ug/L

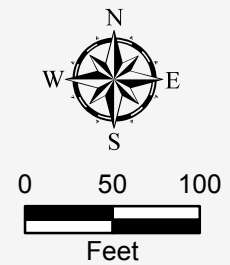



8801 East Marginal Way South
 Tukwila, Washington



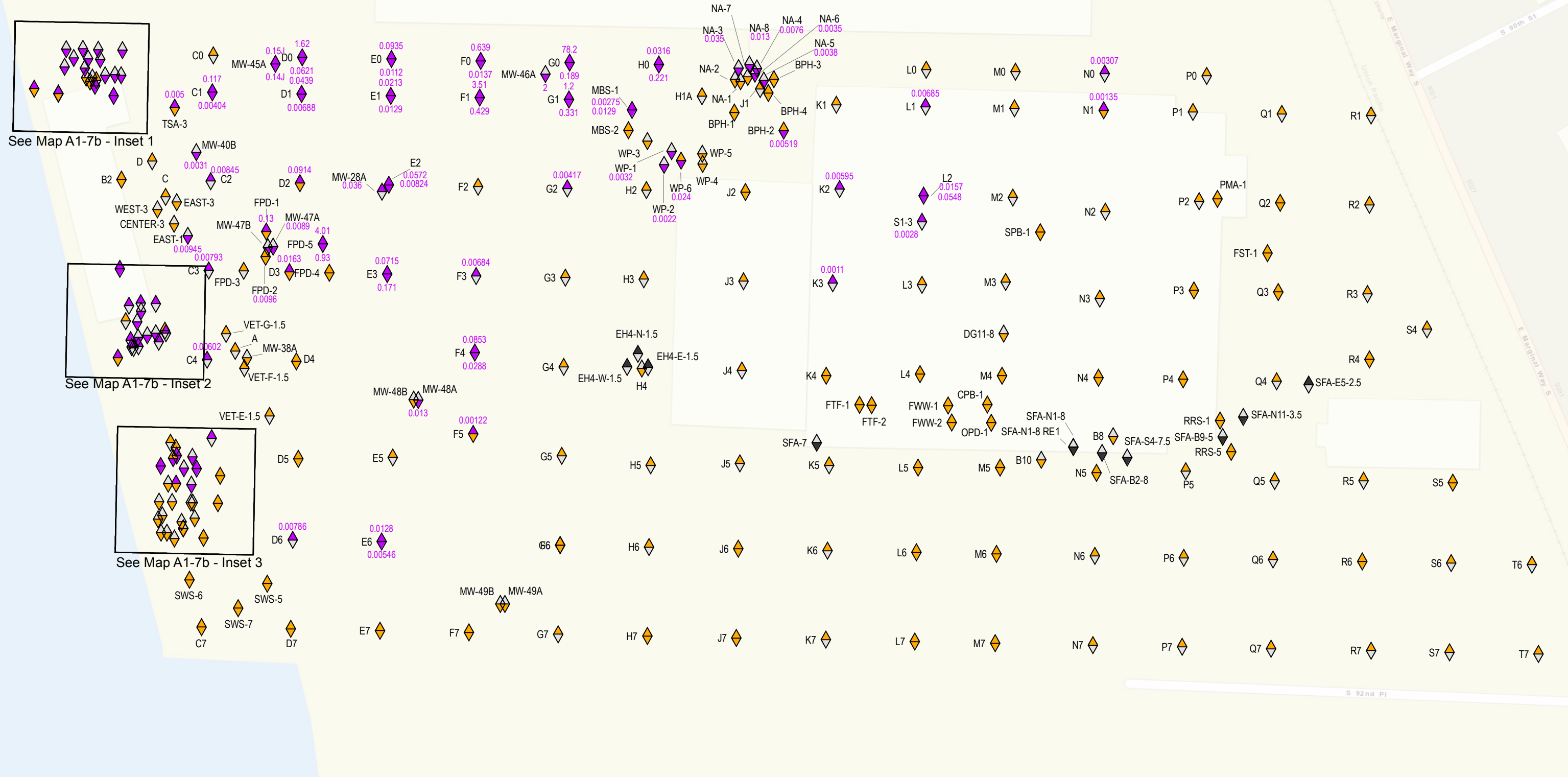

**TOTAL CPAH TEQ
 IN GROUNDWATER**

June 2019 21-1-12567-014



LEGEND

Sample Location
 Unsaturated  Surface to 3 feet
 Saturated 

-  Not Analyzed
-  Analyzed - Not Detected
-  Analyzed - Detected At or Below Screening Level
-  Analyzed - Not Detected and Detection Limit Greater Than Screening Level
-  Analyzed - Detected Greater Than Screening Level

EXAMPLE



Sample Location is F3.
 Sample analyzed and detected greater than screening level.
 Sample result is 0.00684 mg/kg for Unsaturated.

NOTE
 Screening against project proposed cleanup level.
 Trichloroethylene cleanup level in soil is 0.001 mg/kg.

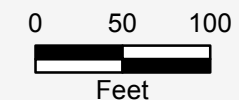

8801 East Marginal Way South
 Tukwila, Washington

**TRICHLOROETHYLENE (TCE)
 IN SOIL**

June 2019

21-1-12567-014

SHANNON & WILSON, INC.
 GEOTECHNICAL AND ENVIRONMENTAL CONSULTANTS

FIG. A-15a

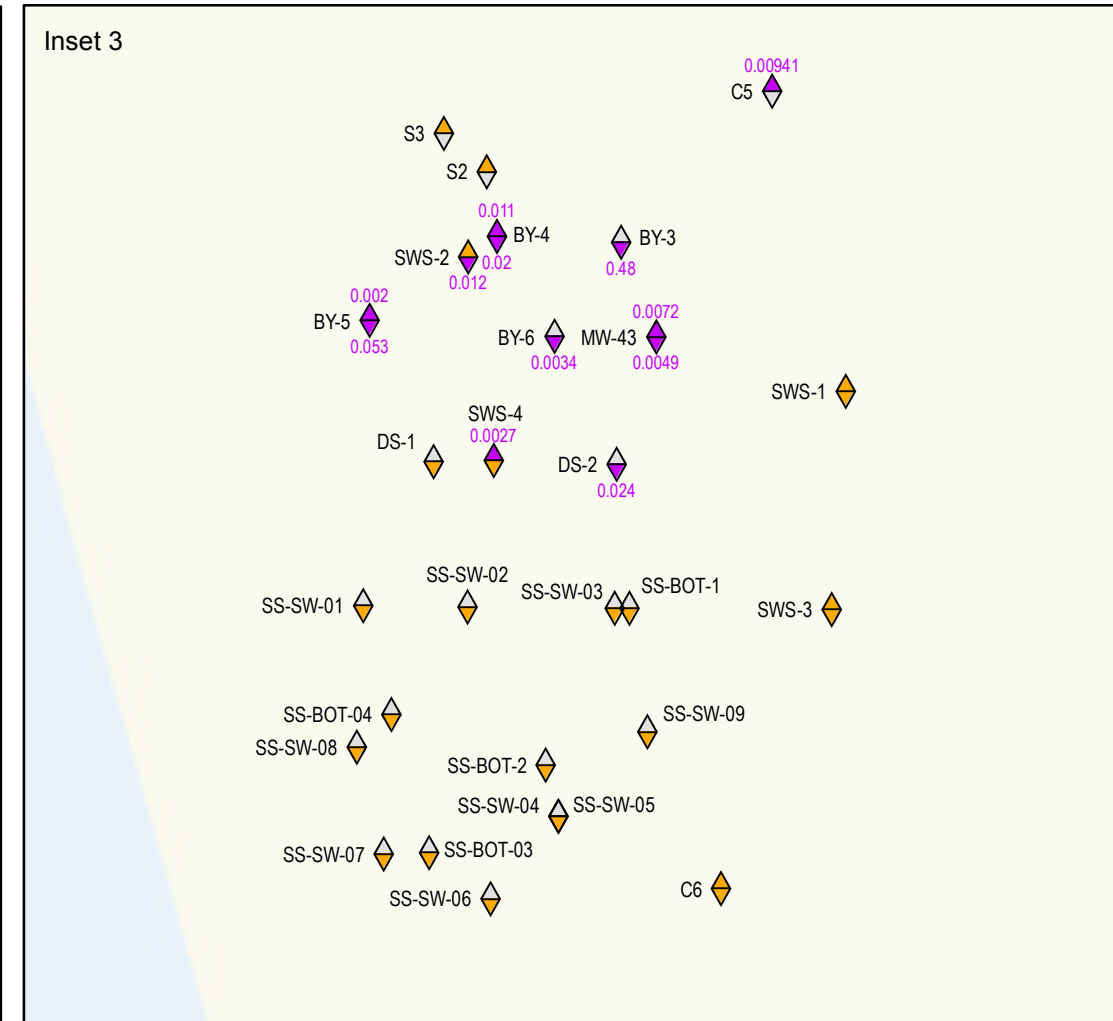
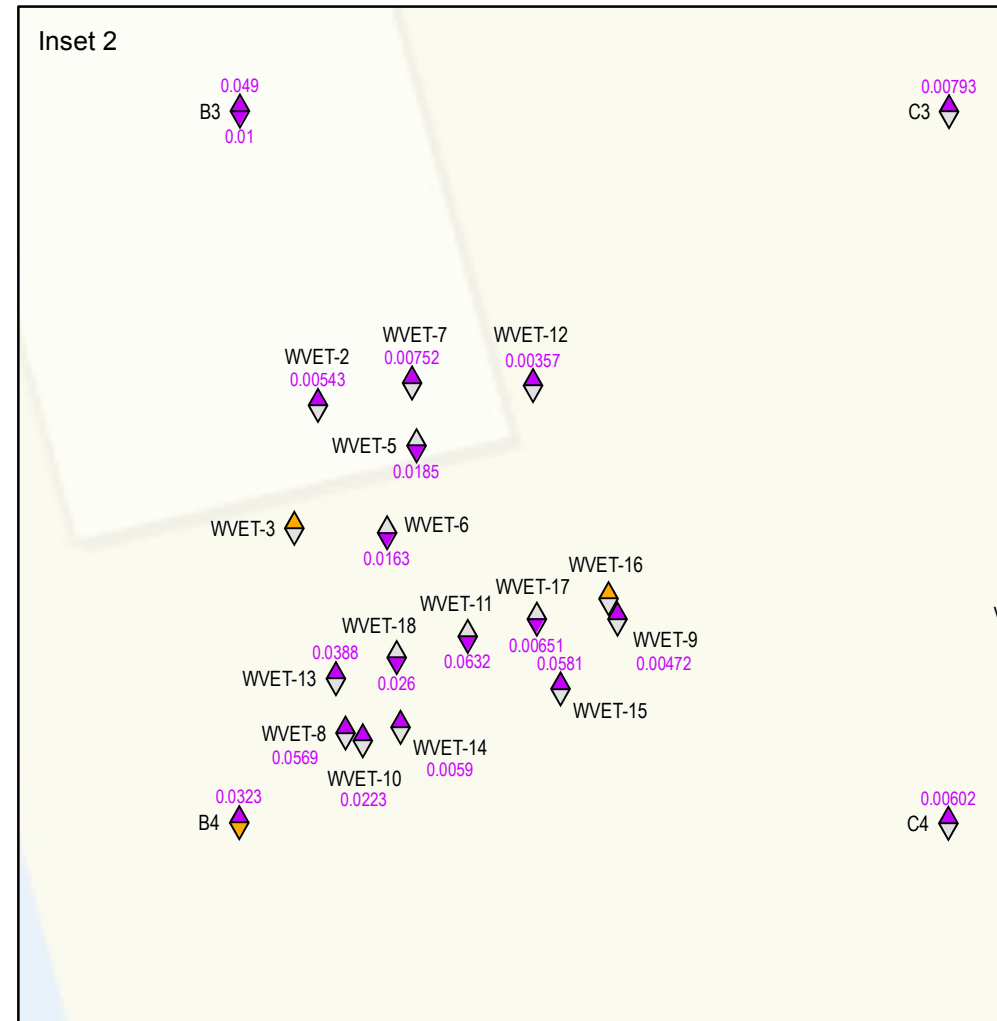
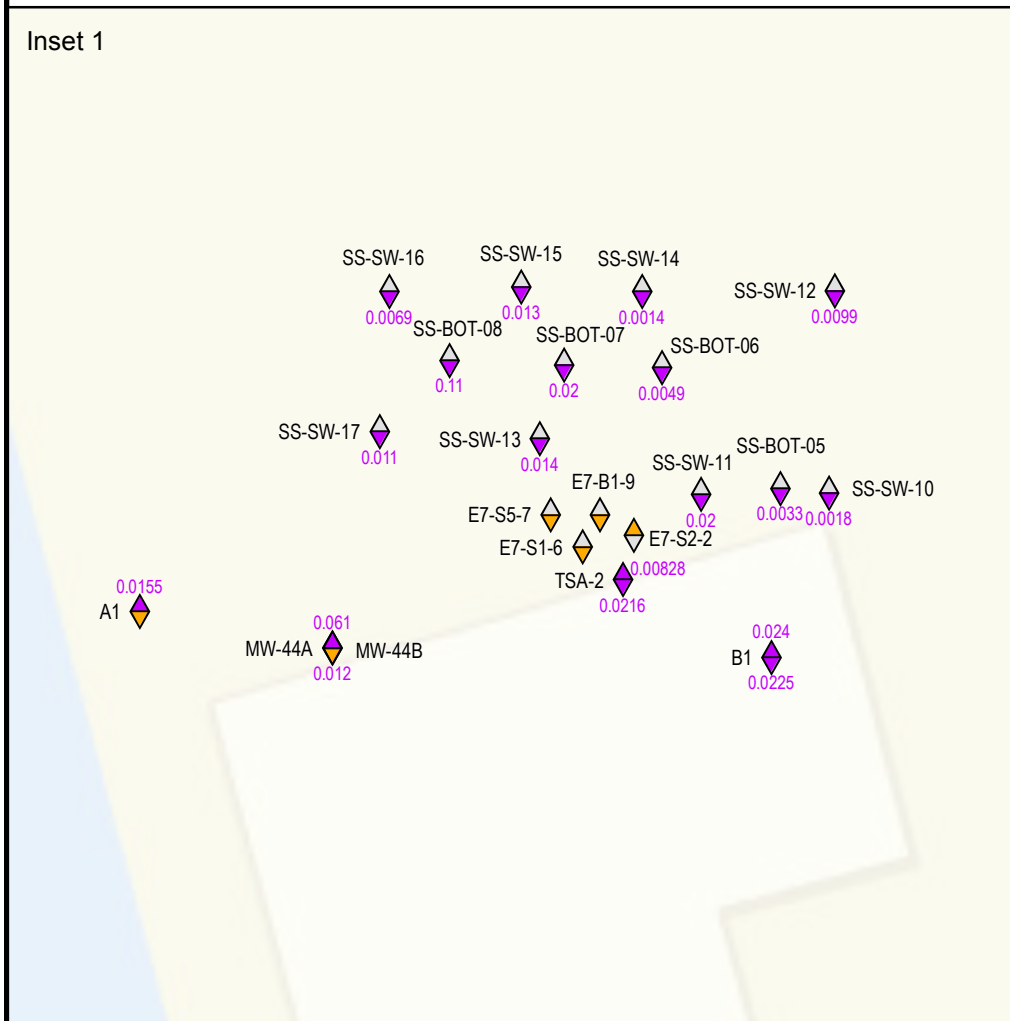

LEGEND

Sample Location
 Unsaturated Surface to 3 feet
 Saturated

- Not Analyzed
- Analyzed - Not Detected
- Analyzed - Detected At or Below Screening Level
- Analyzed - Not Detected and Detection Limit Greater Than Screening Level
- Analyzed - Detected Greater Than Screening Level

EXAMPLE

WWET-2
 0.00543

*Sample Location is WWET-2.
 Sample analyzed and detected greater than screening level.
 Sample result is 0.00543 mg/kg for Unsaturated.*

NOTE
 Screening against project proposed cleanup level.
 Trichloroethylene cleanup level in soil is 0.001 mg/kg.

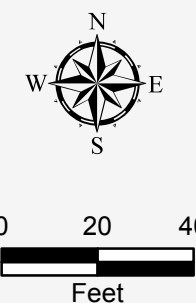

8801 East Marginal Way South
 Tukwila, Washington

**TRICHLOROETHYLENE (TCE)
 IN SOIL**

June 2019 21-1-12567-014

SHANNON & WILSON, INC.
GEOTECHNICAL AND ENVIRONMENTAL CONSULTANTS

FIG. A-15b

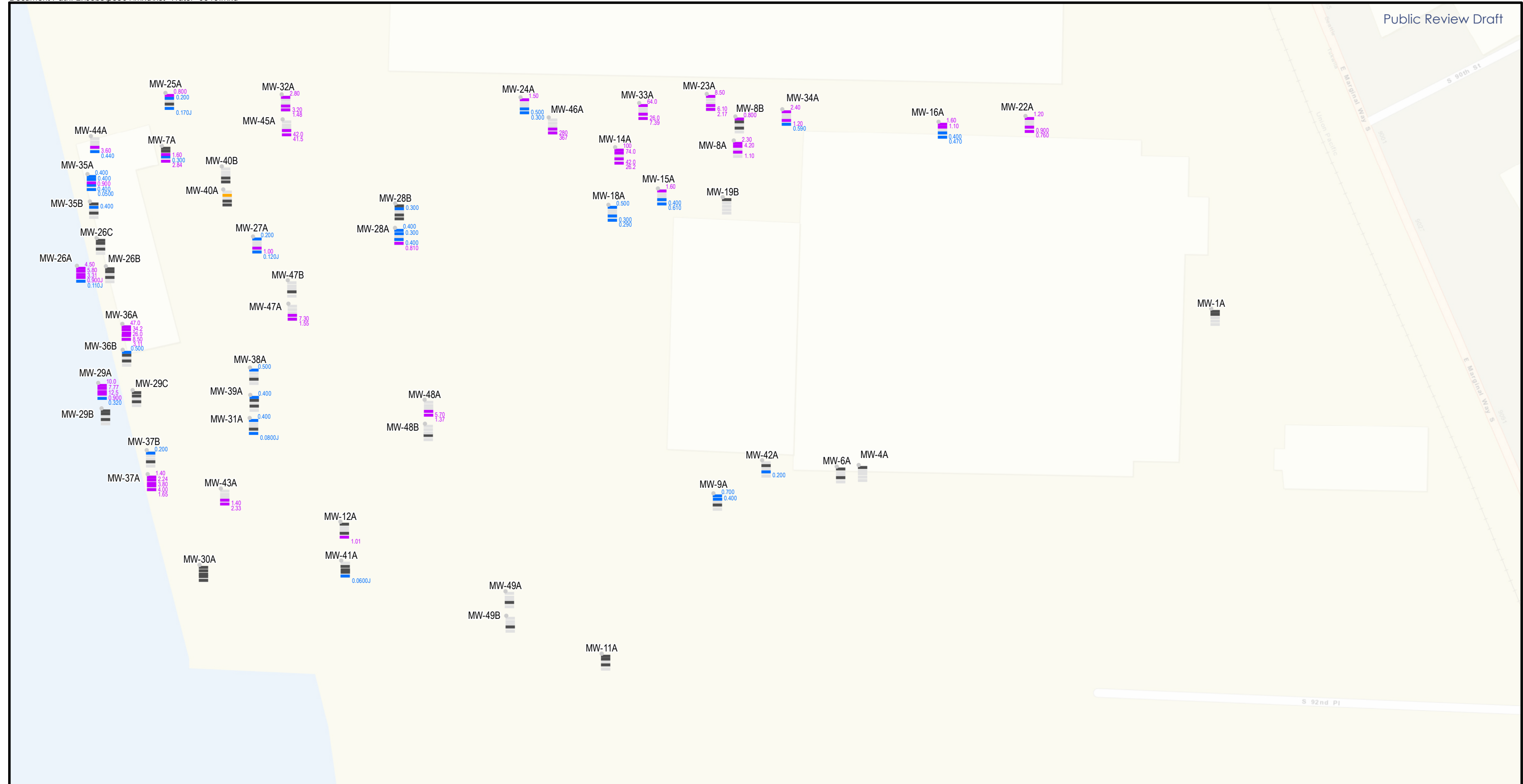

LEGEND

Sample Location

- 2001-2003
- 2004-2006
- 2007-2009
- 2011-Fall
- 2019-Winter

Sample - Date

- Not Analyzed
- Analyzed - Not Detected
- Analyzed - Detected At or Below Screening Level
- Analyzed - Not Detected and Detection Limit Greater Than Screening Level
- Analyzed - Detected Greater Than Screening Level

NOTE
Screening against project proposed cleanup level.
Trichloroethylene (TCE) cleanup level in groundwater is 0.7 ug/L

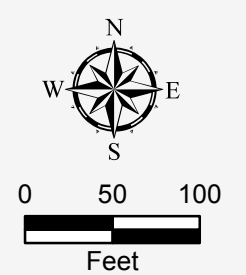

8801 East Marginal Way South
Tukwila, Washington

**TRICHLOROETHYLENE (TCE)
IN GROUNDWATER**

June 2019 21-1-12567-014



See Map A1-8b - Inset 1





See Map A1-8b - Inset 2

See Map A1-8b - Inset 3

LEGEND

Sample Location

Unsaturated  Surface to 3 feet
Saturated 

-  Not Analyzed
-  Analyzed - Not Detected
-  Analyzed - Detected At or Below Screening Level
-  Analyzed - Not Detected and Detection Limit Greater Than Screening Level
-  Analyzed - Detected Greater Than Screening Level

EXAMPLE

MW-28A 1.1



Sample Location is MW-28A.
Sample analyzed and detected greater than screening level.
Sample result is 1.1 mg/kg for Unsaturated.

NOTE
Screening against project proposed cleanup level.
Vinyl chloride cleanup level in soil is 0.001 mg/kg.



0 50 100
Feet

8801 East Marginal Way South
Tukwila, Washington

**VINYL CHLORIDE
IN SOIL**

June 2019 21-1-12567-014

SHANNON & WILSON, INC.
GEOTECHNICAL AND ENVIRONMENTAL CONSULTANTS

FIG. A-17a

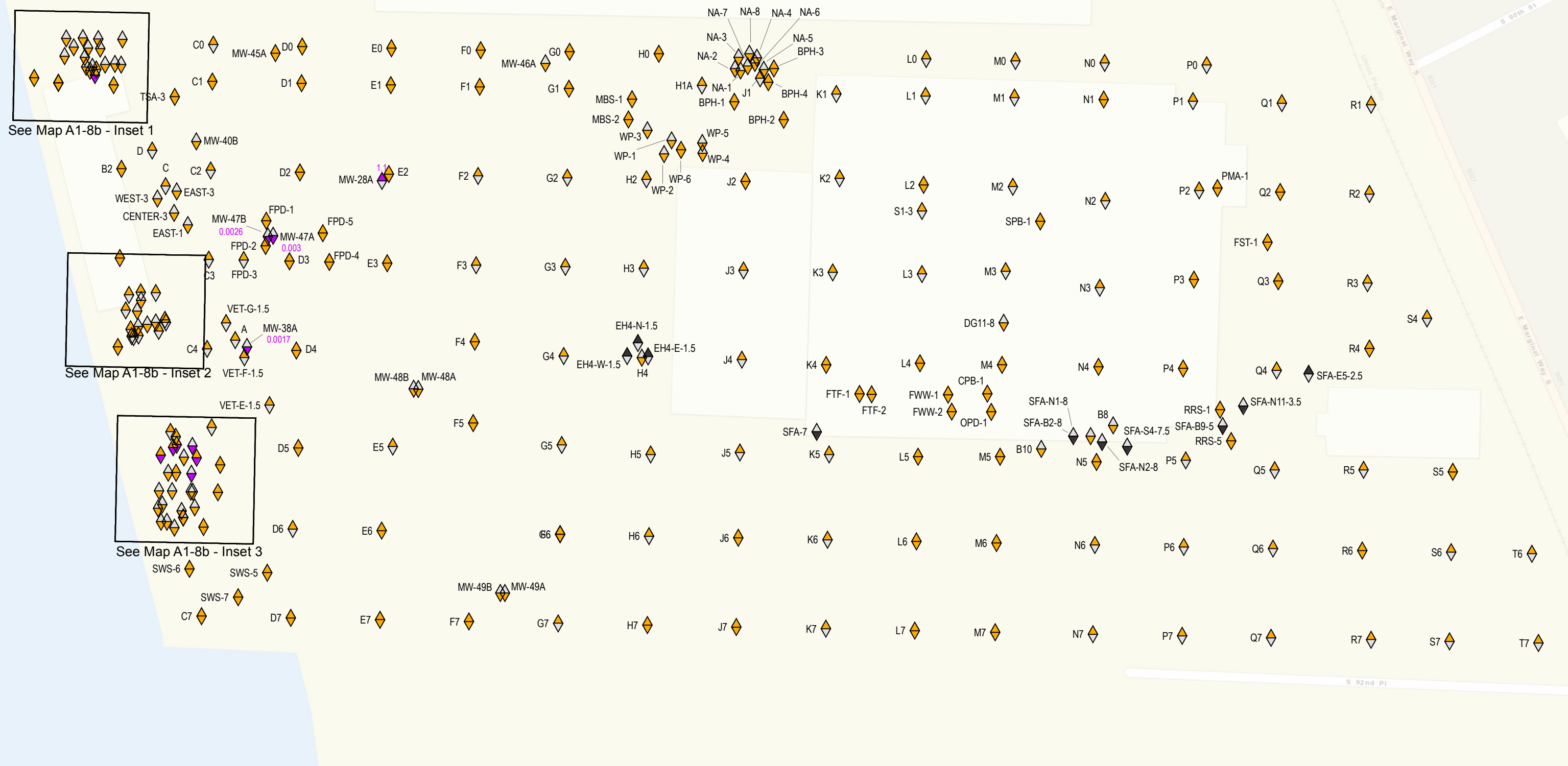

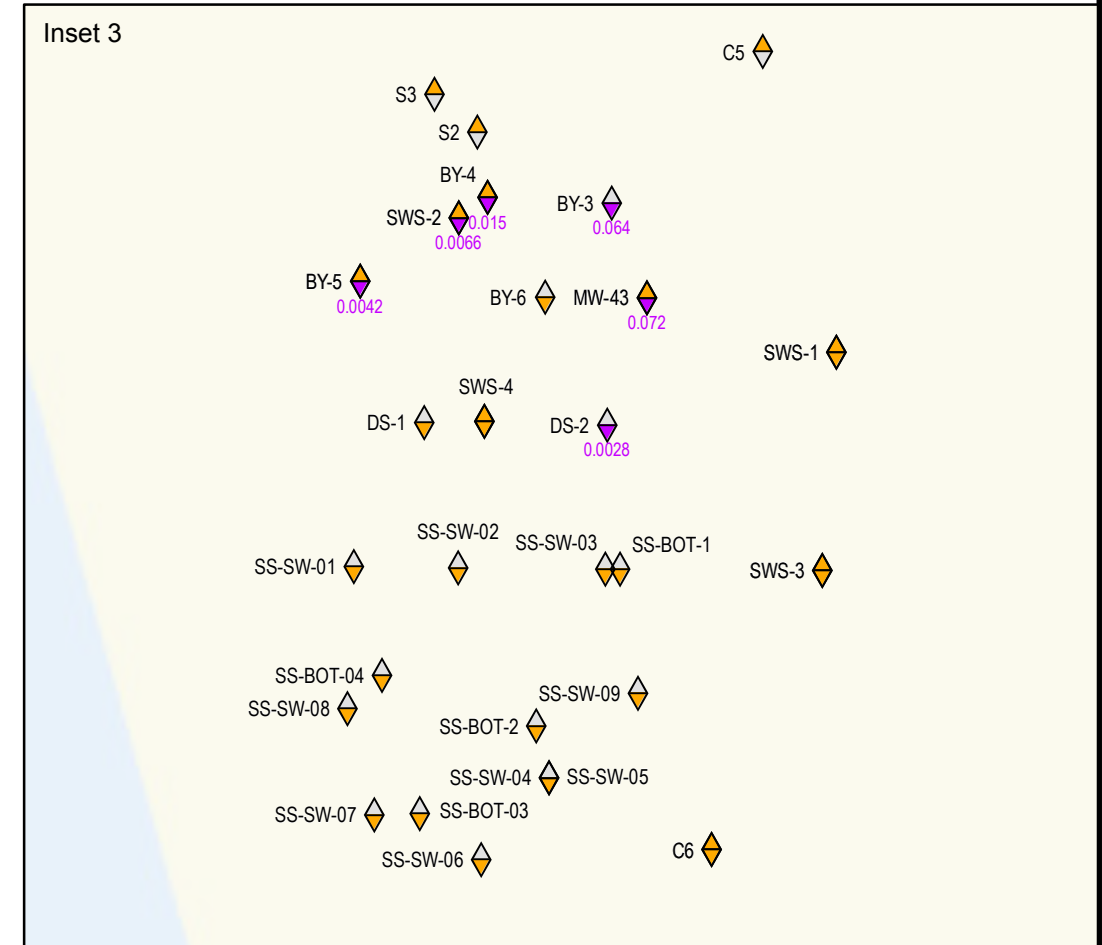
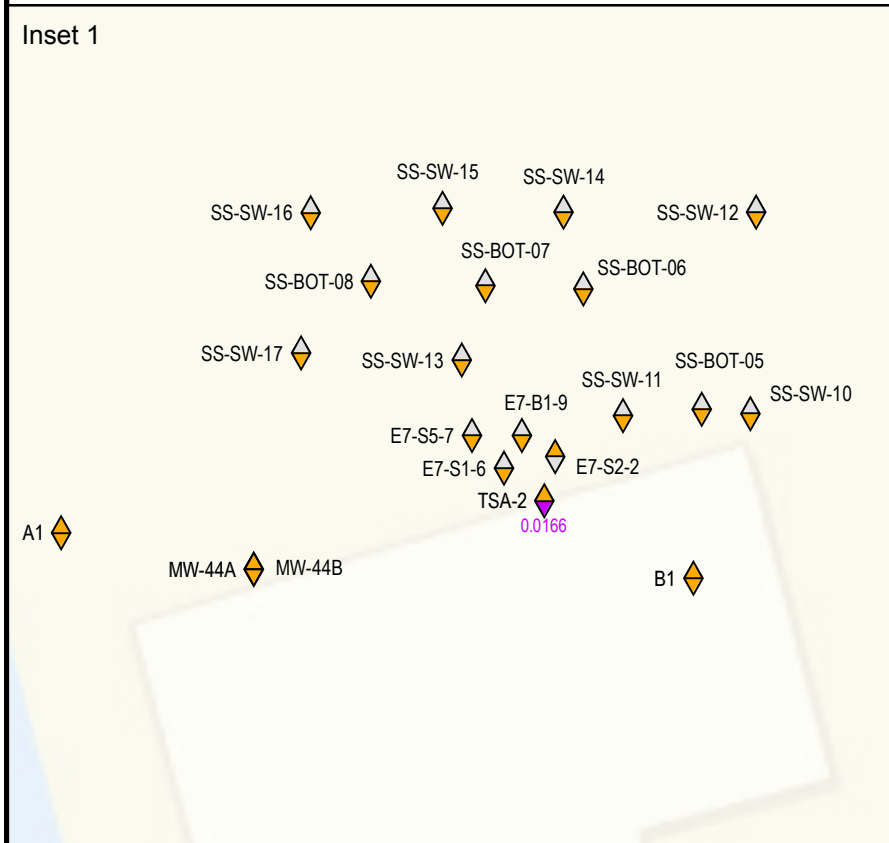

LEGEND

Sample Location
 Unsaturated Surface to 3 feet
 Saturated

- Not Analyzed
- Analyzed - Not Detected
- Analyzed - Detected At or Below Screening Level
- Analyzed - Not Detected and Detection Limit Greater Than Screening Level
- Analyzed - Detected Greater Than Screening Level

EXAMPLE

BY-3
 0.064

*Sample Location is BY-3.
 Sample analyzed and detected greater than screening level.
 Sample result is 0.064 mg/kg for Saturated.*

NOTE
 Screening against project proposed cleanup level. Vinyl chloride cleanup level in soil is 0.001 mg/kg.

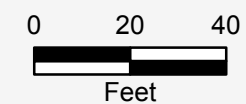

8801 East Marginal Way South
 Tukwila, Washington

**VINYL CHLORIDE
 IN SOIL**

June 2019

21-1-12567-014

SHANNON & WILSON, INC.
GEOTECHNICAL AND ENVIRONMENTAL CONSULTANTS

FIG. A-17b

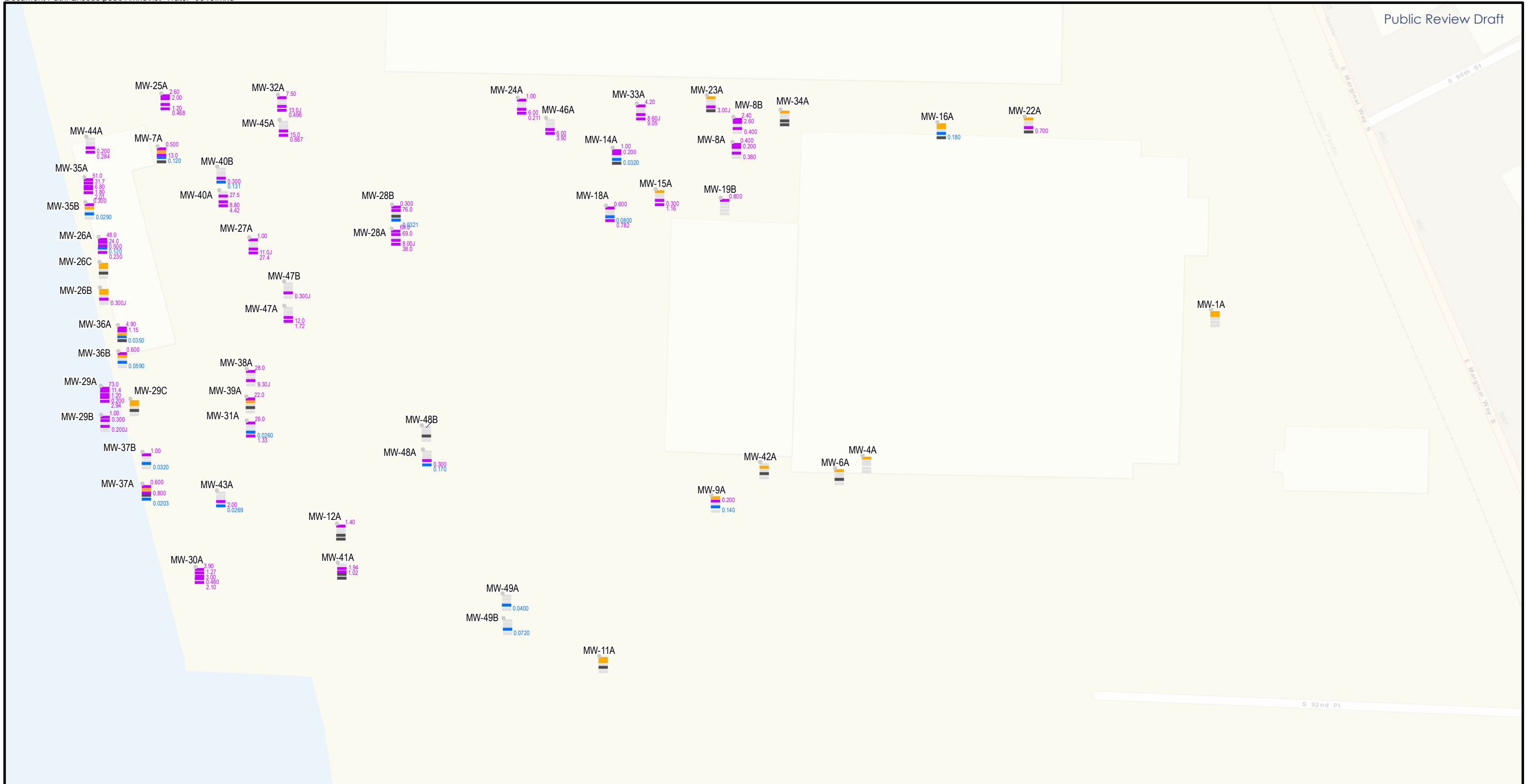

LEGEND

Sample Location

2001-2003
2004-2006
2007-2009
2011-Fall
2019-Winter

Sample - Date

Not Analyzed

Analyzed - Not Detected

Analyzed - Detected At or Below Screening Level

Analyzed - Not Detected and Detection Limit Greater Than Screening Level

Analyzed - Detected Greater Than Screening Level

NOTE
Screening against project proposed cleanup level.
Vinyl chloride cleanup level in groundwater is 0.18 ug/L.

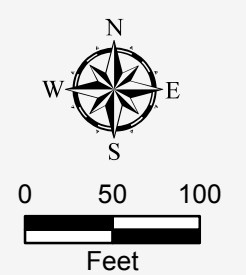

8801 East Marginal Way South
Tukwila, Washington

**VINYL CHLORIDE
IN GROUNDWATER**

June 2019 21-1-12567-014

SHANNON & WILSON, INC.
GEOTECHNICAL AND ENVIRONMENTAL CONSULTANTS

FIG. A-18

Appendix B

Air Exposure Calculations

APPENDIX B: AIR EXPOSURE CALCULATIONS

Table B-1 - Hazard Quotient Summation for Protection of Indoor Air

Chemical	Remediation Levels for Groundwater (µg/L)	Vapor Concentration (generated from Johnson & Ettinger Model, 2017) (µg/m ³)	Method B Indoor Air Concentration (µg/m ³)	Cancer Risk Associated with Groundwater Level	Hazard Quotient Associated with Groundwater Level
Tetrachloroethene	5	0.056	9.62	1.20E-09	1.40E-03
Trichloroethene	5	0.045	0.37	1.82E-07	2.77E-02
cis 1,2-Dichloroethene	130	0.67	--	0	--
1,1-Dichloroethene	700	23	91.4	0	8.00E-02
Vinyl Chloride	2.8	0.13	0.28	5.30E-07	1.28E-03
Total				7.13E-07	0.027595

NOTE:

µg/L = micrograms per liter; µg/m³ = micrograms per meter cubed

Appendix C

Disproportionate Cost Analyses Tables and Graphs

CONTENTS

- Tables C-1A, C-2A, and C-3A: Evaluation of Threshold Requirements
- Tables C-1B, C-2B, and C-3B: Evaluation of Other Requirements and Graphs
- Tables C-1C, C-2C, and C-3C: Cost Breakdowns for Alternatives

Table C-1A - Evaluation of Threshold Requirements - Soil

Preliminary Alternative	Protects human health and the environment	Complies with cleanup standards	Complies with applicable state and federal laws	Provides for compliance monitoring	Carried Forward
No action	No	No	No	No	No
Soil excavation/disposal to CULs (exclude TCE/VC)	Yes	Yes	Yes	Yes	Yes
Soil excavation/disposal to RELs (PCB=0.13 mg/kg, cPAH TEQ=0.1 mg/kg, copper =250 mg/kg, exclude TCE/VC)*	Yes	Yes	Yes	Yes	Yes
Soil excavation/disposal to RELs (PCB=0.5 mg/kg, cPAH TEQ=0.6 mg/kg, copper =250 mg/kg, exclude TCE/VC)*	Yes	Yes	Yes	Yes	Yes
Cap and institutional controls on areas exceeding CULs (exclude TCE/VC)	Yes	Yes	Yes	Yes	Yes
MNA only	No	No	Yes	Yes	No

NOTES:

*Includes excavation of known locations with arsenic exceeding REL, gasoline exceeding CUL, and dioxins/furans exceeding natural background. TCE/VC are addressed in groundwater alternatives.
cPAH = carcinogenic polycyclic aromatic hydrocarbons; mg/kg = milligrams per kilogram; MNA = monitored natural attenuation; PCB = polychlorinated biphenyl; REL = remediation level;
TCE = trichloroethylene; TEQ = toxicity equivalent quotient; VC = vinyl chloride

Table C-1B - Evaluation of Other Requirements - Soil

Alternative No.	1a - Excavation/disposal to CULs	1b - Excavation/disposal to RELs with institutional controls, RELs: PCB = 0.5 mg/kg cPAH TEO = 0.6 mg/kg copper = 250 mg/kg	1c - Excavation/disposal to RELs with institutional controls, RELs: PCB = 0.13 mg/kg cPAH TEO = 0.1 mg/kg copper = 250 mg/kg	1d - Cap and institutional controls
Brief Description	Excavate soil that exceeds CULs and is within 15 feet of ground surface. TCE/VC are not excavated and are addressed in groundwater alternatives. Dewater excavation and treat groundwater.	Excavate soil that exceeds RELs and is within 15 feet of ground surface. Includes excavation of known locations with arsenic exceeding REL, gasoline exceeding CUL, and dioxins/furans exceeding natural background. TCE/VC are not excavated and are addressed in groundwater alternatives. Dewater excavation and treat groundwater. Cover areas which remain above CULs and establish institutional controls.	Excavate soil that exceeds RELs and is within 15 feet of ground surface. Includes excavation of known locations with arsenic exceeding REL, gasoline exceeding CUL, and dioxins/furans exceeding natural background. TCE/VC are not excavated and are addressed in groundwater alternatives. Dewater excavation and treat groundwater. Cover areas which remain above CULs and establish institutional controls.	Cover unsaturated soil in areas that exceeds CULs. Establish institutional controls.
Considers public concerns?				
Considers public concerns?	Yes	Yes	Yes	Yes
Reasonable restoration time frame? [WAC 173-340-360(4)]				
Estimated restoration time frame (years)	2	3	3	10
Toxicity of COCs	High PCBs and cPAHs	High PCBs and cPAHs	High PCBs and cPAHs	High PCBs and cPAHs
Risk to human health and environment during remedy	Moderate Workers will have moderate exposures	Moderate Workers will have moderate exposures	Moderate Workers will have moderate exposures	Low Low worker exposure since pavement exists over most surfaces
Has natural attenuation been documented to occur on site?	Not applicable Not applicable to this alternative	Not applicable Not applicable to this alternative	Not applicable Not applicable to this alternative	Not applicable Not applicable to this alternative
Practical to achieve shorter restoration time frame? (includes consideration of natural attenuation)	No --	Yes Excavation of all soil exceeding CULs is expected to be faster, but time frame still reasonable.	Yes Excavation of all soil exceeding CULs is expected to be faster, but time frame still reasonable.	Yes Excavation of some or all soil exceeding screening levels would accelerate restoration timeline.
Consistent with current use of site, surrounding area, & resources?	Yes Property is vacant. Activities will not affect surrounding businesses.	Yes Property is vacant. Activities will not affect surrounding businesses.	Yes Property is vacant. Activities will not affect surrounding businesses.	Yes Property is vacant. Activities will not affect surrounding businesses.
Consistent with planned future use of site, surrounding area, & resources?	Yes No impacts off-site	Yes No impacts off-site	Yes No impacts off-site	Yes No impacts off-site
Availability of alternate water supply	Not Applicable Groundwater not used	Not Applicable Groundwater not used	Not Applicable Groundwater not used	Not Applicable Groundwater not used
Effectiveness and reliability of institutional controls	Not Applicable No institutional controls	High Maintain pavement Prevent use of groundwater	High Maintain pavement Prevent use of groundwater	High Maintain pavement Prevent use of groundwater
Ability to monitor and control chemical migration from site	Not Applicable No impacts off-site	Yes Maintain pavement	Yes Maintain pavement	Yes Maintain pavement

Table C-1B - Evaluation of Other Requirements - Soil

Alternative No.	1a - Excavation/disposal to CULs	1b - Excavation/disposal to RELs with institutional controls, RELs: PCB = 0.5 mg/kg cPAH TEQ = 0.6 mg/kg copper = 250 mg/kg	1c - Excavation/disposal to RELs with institutional controls, RELs: PCB = 0.13 mg/kg cPAH TEQ = 0.1 mg/kg copper = 250 mg/kg	1d - Cap and institutional controls	
Brief Description	Excavate soil that exceeds CULs and is within 15 feet of ground surface. TCE/VC are not excavated and are addressed in groundwater alternatives. Dewater excavation and treat groundwater.	Excavate soil that exceeds RELs and is within 15 feet of ground surface. Includes excavation of known locations with arsenic exceeding REL, gasoline exceeding CUL, and dioxins/furans exceeding natural background. TCE/VC are not excavated and are addressed in groundwater alternatives. Dewater excavation and treat groundwater. Cover areas which remain above CULs and establish institutional controls.	Excavate soil that exceeds RELs and is within 15 feet of ground surface. Includes excavation of known locations with arsenic exceeding REL, gasoline exceeding CUL, and dioxins/furans exceeding natural background. TCE/VC are not excavated and are addressed in groundwater alternatives. Dewater excavation and treat groundwater. Cover areas which remain above CULs and establish institutional controls.	Cover unsaturated soil in areas that exceeds CULs. Establish institutional controls.	
Permanent to maximum extent practicable? [disproportionate cost analysis, WAC 173-340-360(3)]					
<i>Benefit evaluation</i>					
Overall protectiveness	30%	10	8	8	3
		Contamination exceeding CULs removed.	Contamination exceeding RELs removed. Contamination exceeding CULs remain on site and are capped. 92.1% of mass of PCBs, cPAHs, and copper removed.	Contamination exceeding RELs removed. Contamination exceeding CULs remain on site and are capped. 92.1% of mass of PCBs, cPAHs, and copper removed.	No contamination removed from the site. Contamination exceeding CULs are capped.
Permanence	20%	10	7	7	2
		Contamination exceeding CULs removed from the site.	Contamination exceeding RELs removed. Contamination exceeding CULs remain on site and are capped. Some contaminants naturally attenuate and other contaminants do not.	Contamination exceeding RELs removed. Contamination exceeding CULs remain on site and are capped. Some contaminants naturally attenuate and other contaminants do not.	Some contaminants naturally attenuate and other contaminants do not.
Effectiveness over long-term	20%	8.5	6	6	3
		Contaminated materials are removed from the site.	Contaminated materials with higher concentrations are removed from site. Residual contamination is capped and may have the potential to leach to groundwater.	Contaminated materials with higher concentrations are removed from site. Residual contamination is capped and may have the potential to leach to groundwater.	Contaminated materials remain on site and have the potential to leach to groundwater.
Management of short-term risks	10%	2	7	6	9
		Extensive excavation will expose workers	Smaller and fewer excavations are easier to control	Smaller excavations are easier to control	No excavation. Low risk.
Technical and administrative implementability	10%	2	5	4	8
		Large scale excavation is more difficult than other alternatives. Also, excavating below water table is difficult but proven methods exist.	Smaller and fewer excavations are easier to implement.	Smaller excavations are easier to implement.	No excavation. Installing cap is relatively straightforward.
Consideration of public concerns	10%	4	6	6	9
		Visible impacts would be sitewide and large quantity of excavated contaminated materials are transported through the surrounding neighborhood. However, the surrounding area is industrial.	Visible impacts would be present sitewide; however, the surrounding area is industrial and excavated quantities would not be exceptional.	Visible impacts would be present sitewide; however, the surrounding area is industrial and excavated quantities would not be exceptional.	Visible impacts would be present sitewide; however, the surrounding area is industrial and no material would be excavated.
Overall weighted benefit score	100%	7.5	6.8	6.6	4.5

Table C-1B - Evaluation of Other Requirements - Soil

Alternative No.	1a - Excavation/disposal to CULs	1b - Excavation/disposal to RELs with institutional controls, RELs: PCB = 0.5 mg/kg cPAH TEQ = 0.6 mg/kg copper = 250 mg/kg	1c - Excavation/disposal to RELs with institutional controls, RELs: PCB = 0.13 mg/kg cPAH TEQ = 0.1 mg/kg copper = 250 mg/kg	1d - Cap and institutional controls
Brief Description	Excavate soil that exceeds CULs and is within 15 feet of ground surface. TCE/VC are not excavated and are addressed in groundwater alternatives. Dewater excavation and treat groundwater.	Excavate soil that exceeds RELs and is within 15 feet of ground surface. Includes excavation of known locations with arsenic exceeding REL, gasoline exceeding CUL, and dioxins/furans exceeding natural background. TCE/VC are not excavated and are addressed in groundwater alternatives. Dewater excavation and treat groundwater. Cover areas which remain above CULs and establish institutional controls.	Excavate soil that exceeds RELs and is within 15 feet of ground surface. Includes excavation of known locations with arsenic exceeding REL, gasoline exceeding CUL, and dioxins/furans exceeding natural background. TCE/VC are not excavated and are addressed in groundwater alternatives. Dewater excavation and treat groundwater. Cover areas which remain above CULs and establish institutional controls.	Cover unsaturated soil in areas that exceeds CULs. Establish institutional controls.
Cost evaluation (\$M)				
Initial capital cost to construct	15.18	2.90	3.75	0.578
Annual O&M cost	0.20	1.87	1.87	0.7274
Estimated restoration time frame [years]	2	3	3	10
O&M cost over restoration timeframe	0.41	5.60	5.60	7.27
Total cost over life of remedy	15.59	8.50	9.35	7.85
Ratio of benefit/cost	0.48	0.80	0.71	0.57

NOTES:

cPAH = carcinogenic polycyclic aromatic hydrocarbons; CUL = preliminary cleanup level; mg/kg = milligrams per kilogram; PCB = polychlorinated biphenyl; REL = remediation level; TCE = trichloroethylene; TEQ = toxicity equivalent quotient; VC = vinyl chloride

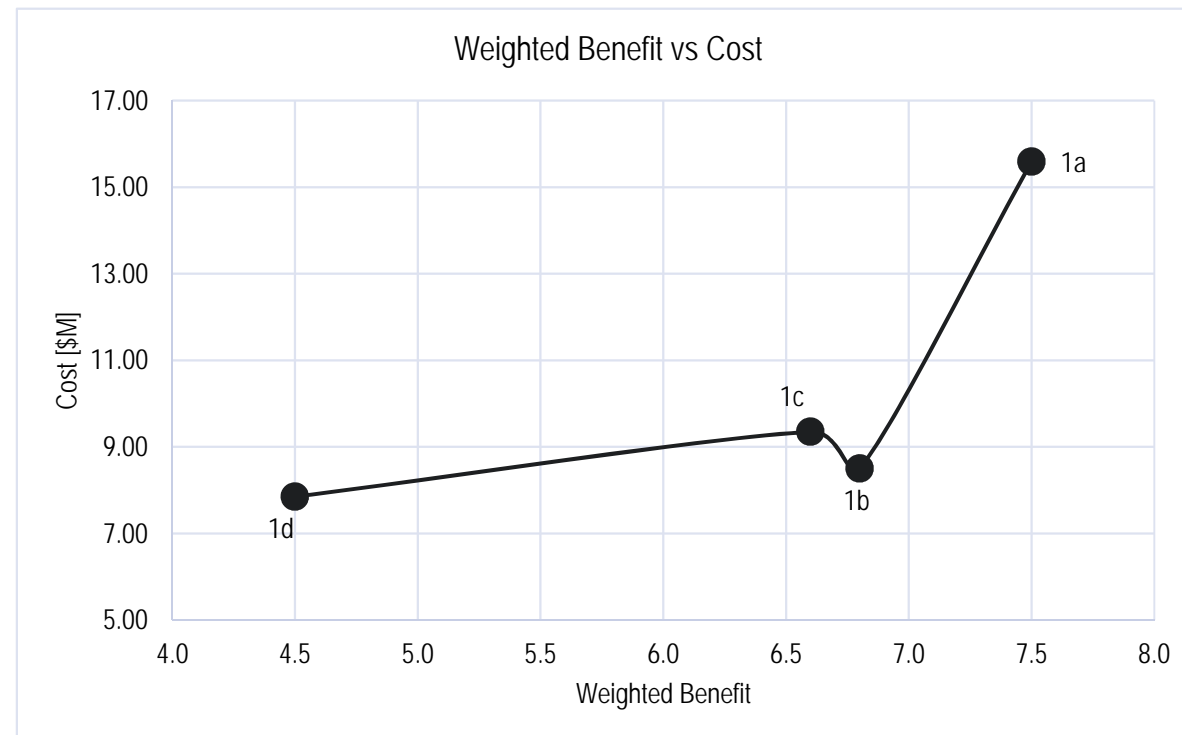

Table C-1C - Cost Breakdown for Soil Alternatives

Alternative No.	1a - Excavation/disposal to CULs	1b - Excavation/disposal to RELs with institutional controls, RELs: PCB = 0.5 mg/kg cPAH TEQ = 0.6 mg/kg copper = 250 mg/kg	1c - Excavation/disposal to RELs with institutional controls, RELs: PCB = 0.13 mg/kg cPAH TEQ = 0.1 mg/kg copper = 250 mg/kg	1d - Cap and institutional controls
Brief Description	Excavate soil that exceeds CULs and is within 15 feet of ground surface. TCE/VC are not excavated and are addressed in groundwater alternatives. Dewater excavation and treat groundwater.	Excavate soil that exceeds RELs and is within 15 feet of ground surface. Includes excavation of known locations with arsenic exceeding REL, gasoline exceeding CUL, and dioxins/furans exceeding natural background. TCE/VC are not excavated and are addressed in groundwater alternatives. Dewater excavation and treat groundwater. Cover areas which remain above CULs and establish institutional controls.	Excavate soil that exceeds RELs and is within 15 feet of ground surface. Includes excavation of known locations with arsenic exceeding REL, gasoline exceeding CUL, and dioxins/furans exceeding natural background. TCE/VC are not excavated and are addressed in groundwater alternatives. Dewater excavation and treat groundwater. Cover areas which remain above CULs and establish institutional controls.	Cover unsaturated soil in areas that exceeds CULs. Establish institutional controls.
Capital Costs				
Capital Direct Cost (Installed)				
Mob/Demob	\$1,000	\$463	\$513	\$14
Site Survey	\$10	\$34	\$49	\$9
Concrete breaking	\$842	\$116	\$145	
Shoring system		\$116	\$184	
Excavation of solid waste	\$533	\$108	\$124	
Off-site disposal of solid waste excavated	\$3,680	\$728	\$794	
Borrowed clean fill	\$1,333	\$270	\$335	
Surface Restoration/capping	\$3,078	\$424	\$765	\$453
AS Well Driller/Installation				
Injection Event				
Initial Injection Event				
Plumbing				
Treatment equipment				
Water disposal/ treatment	\$900	\$182	\$202	
Catch basin/filter installation				
Sampling/analysis for the compliance measure	\$138	\$37	\$55	
Installing new wells	\$150	\$10	\$12	
Reagent				
Well Abandonment	\$27	\$2	\$3	
Capital Indirect Costs				
Engineering/Oversite/Documentation	\$2,200	\$118	\$199	\$19
Ecology Oversight	\$50	\$12	\$18	\$6
Construction QA and Management	See above	See above	See above	
Closure Documentation	\$17	\$17	\$17	\$17
Tukwila Business Permit	\$10	\$10	\$10	\$10
Combined Tukwila Taxes and Fees (10% capital costs, 2% Labor)	\$1,214	\$252	\$323	\$48
Total Capital Cost	\$15,182	\$2,899	\$3,747	\$578

Table C-1C - Cost Breakdown for Soil Alternatives

Alternative No.	1a - Excavation/disposal to CULs	1b - Excavation/disposal to RELs with institutional controls, RELs: PCB = 0.5 mg/kg cPAH TEQ = 0.6 mg/kg copper = 250 mg/kg	1c - Excavation/disposal to RELs with institutional controls, RELs: PCB = 0.13 mg/kg cPAH TEQ = 0.1 mg/kg copper = 250 mg/kg	1d - Cap and institutional controls
Brief Description	Excavate soil that exceeds CULs and is within 15 feet of ground surface. TCE/VC are not excavated and are addressed in groundwater alternatives. Dewater excavation and treat groundwater.	Excavate soil that exceeds RELs and is within 15 feet of ground surface. Includes excavation of known locations with arsenic exceeding REL, gasoline exceeding CUL, and dioxins/furans exceeding natural background. TCE/VC are not excavated and are addressed in groundwater alternatives. Dewater excavation and treat groundwater. Cover areas which remain above CULs and establish institutional controls.	Excavate soil that exceeds RELs and is within 15 feet of ground surface. Includes excavation of known locations with arsenic exceeding REL, gasoline exceeding CUL, and dioxins/furans exceeding natural background. TCE/VC are not excavated and are addressed in groundwater alternatives. Dewater excavation and treat groundwater. Cover areas which remain above CULs and establish institutional controls.	Cover unsaturated soil in areas that exceeds CULs. Establish institutional controls.
Periodic Costs				
Semi-Annual Vapor Control Maintenance				
Cap Inspection/Maintenance Costs- Institutional Control		\$406 30 year total	\$406 30 year total	\$406 30 year total
Annual Sampling/Monitoring/Reporting*	\$400 2 years	\$4,000 30 year total	\$4,000 30 year total	\$5,556 30 year total
Project Management/Seal Inspection		\$150	\$150	\$234
5-Year Reporting		\$936	\$936	\$936
Combined Sales Tax for Tukwila, Washington (10% capital costs, 2% Labor)	\$8	\$110	\$110	\$143
Total Periodic Cost: (@2019)	\$408	\$5,602	\$5,602	\$7,274
Total Cleanup Cost (Capital + Periodic Cost): @ 2019yr				
Average	\$15,590	\$8,501	\$9,349	\$7,852
Low End (-30%)	\$10,913	\$5,951	\$6,544	\$5,496
High End (+50%)	\$23,385	\$12,751	\$14,024	\$11,778

NOTES:

*Annual stormwater maintenance costs are incurred by owner/tenant and not included within this cost estimate.

Costs do not include net present worth adjustment.

Costs are in thousands of dollars.

cPAH = carcinogenic polycyclic aromatic hydrocarbons; CUL = preliminary cleanup level; mg/kg = milligrams per kilogram; PCB = polychlorinated biphenyl; REL = remediation level; TCE = trichloroethylene; TEQ = toxicity equivalent quotient; VC = vinyl chloride

Table C-2A - Evaluation of Threshold Requirements - Groundwater

Preliminary Alternative	Protects human health and the environment	Complies with cleanup standards	Complies with applicable state and federal laws	Provides for compliance monitoring	Carried Forward
No action	No	No	No	No	No
Excavate TCE to CUL, ERD, PCB-containing caulk removal, AS/SVE expansion, institutional controls for vapor	Yes	Yes	Yes	Yes	Yes
Excavate TCE to REL, ERD, PCB-containing caulk removal, AS/SVE expansion, institutional controls for vapor	Yes	Yes	Yes	Yes	Yes
Excavate TCE to REL, MNA across TCE plume, PCB-containing caulk removal, AS/SVE expansion, institutional controls for vapor	Yes	Yes	Yes	Yes	Yes
Excavate TCE to REL, ERD, PCB-containing caulk removal, MNA to west of existing AS/SVE, institutional controls for vapor	Yes	Yes	Yes	Yes	Yes
MNA only	No	No	Yes	Yes	No

NOTES:

AS/SVE = air sparging/soil vapor extraction system; ERD = enhanced reductive dechlorination; MNA = monitored natural attenuation; PCB = polychlorinated biphenyl; REL = remediation level; TCE = trichloroethylene; VC = vinyl chloride

Table C-2B - Evaluation of Other Requirements - Groundwater

Alternative No.	2a - Excavate TCE to CUL, ERD, PCB-containing caulk removal, AS/SVE expansion, institutional controls for vapor	2b - Excavate TCE to REL, ERD, PCB-containing caulk removal, AS/SVE expansion, institutional controls for vapor	2c - Excavate TCE to REL, MNA across TCE plume, PCB-containing caulk removal, AS/SVE expansion, institutional controls for vapor	2d - Excavate TCE to REL, ERD, PCB-containing caulk removal, MNA to west of existing AS/SVE, institutional controls for vapor
Brief Description	Excavate soil that exceeds the CUL for TCE and is above 15 feet bgs. Perform injection to promote ERD. Remove PCB-containing caulk near MW-16A and MW-34A. Expand existing AS/SVE system to the west. Establish institutional controls for vapor intrusion.	Excavate soil that exceeds the REL for TCE (5 µg/L) and is above 15 feet bgs. Perform injection to promote ERD. Remove PCB-containing caulk near MW-16A and MW-34A. Expand existing AS/SVE system to the west. Establish institutional controls for vapor intrusion.	Excavate soil that exceeds the REL for TCE (5 µg/L) and is above 15 feet bgs. Perform groundwater monitoring on all the existing monitoring wells for 30-year period. Remove PCB-containing caulk near MW-16A and MW-34A. Expand existing AS/SVE system to the west. Establish institutional controls for vapor intrusion.	Excavate soil that exceeds the REL for TCE (5 µg/L) and is above 15 feet bgs. Perform injection to promote ERD. Remove PCB-containing caulk near MW-16A and MW-34A. Establish institutional controls for vapor intrusion. AS/SVE system operates but is not expanded.
Considers public concerns?				
Considers public concerns?	Yes	Yes	Yes	Yes
Reasonable restoration time frame? [WAC 173-340-360(4)]				
Estimated restoration time frame (years)	8	10	20	20
Toxicity of COCs	High TCE and VC	High TCE and VC	High TCE and VC	High TCE and VC
Risk to human health and environment during remedy	Moderate Workers will have moderate exposures	Low Workers will have moderate exposures but less than excavating TCE to the CUL	Low Workers will have moderate exposures but less than excavating TCE to the CUL	Low Workers will have moderate exposures but less than excavating TCE to the CUL
Has natural attenuation been documented to occur on site?	Yes Not applicable to this alternative	Yes Not applicable to this alternative	Yes MNA used in this alternative	Yes MNA used in this alternative
Practical to achieve shorter restoration time frame? (includes consideration of natural attenuation)	No --	Yes Excavation of all soil exceeding CULs is expected to be faster, but time frame still reasonable.	Yes Excavation of all soil exceeding CULs is expected to be faster, but time frame still reasonable.	Yes Excavation of all soil exceeding CULs is expected to be faster, but time frame still reasonable.
Consistent with current use of site, surrounding area, & resources?	Yes Property is vacant. Activities will not affect surrounding businesses.	Yes Property is vacant. Activities will not affect surrounding businesses.	Yes Property is vacant. Activities will not affect surrounding businesses.	Yes Property is vacant. Activities will not affect surrounding businesses.
Consistent with planned future use of site, surrounding area, & resources?	Yes Removes sources to surrounding area.	Yes Removes sources to surrounding area.	Yes Removes sources to surrounding area.	Yes Removes sources to surrounding area.
Availability of alternate water supply	Not Applicable Groundwater not used	Not Applicable Groundwater not used	Not Applicable Groundwater not used	Not Applicable Groundwater not used
Effectiveness and reliability of institutional controls	Moderate Design future structures to limit vapor intrusion.	Moderate Maintain pavement, and design future structures to limit vapor intrusion.	Moderate Maintain pavement, and design future structures to limit vapor intrusion.	Moderate Maintain pavement, and design future structures to limit vapor intrusion.
Ability to monitor and control chemical migration from site	Yes Monitored using wells. Chemical migration limited using injection and existing and expanded AS/SVE.	Yes Monitored using wells. Chemical migration limited using injection and existing and expanded AS/SVE.	Yes Monitored using wells. Chemical migration limited using existing and expanded AS/SVE.	Yes Monitored using wells. Chemical migration limited using existing AS/SVE.

Table C-2B - Evaluation of Other Requirements - Groundwater

Alternative No.	2a - Excavate TCE to CUL, ERD, PCB-containing caulk removal, AS/SVE expansion, institutional controls for vapor	2b - Excavate TCE to REL, ERD, PCB-containing caulk removal, AS/SVE expansion, institutional controls for vapor	2c - Excavate TCE to REL, MNA across TCE plume, PCB-containing caulk removal, AS/SVE expansion, institutional controls for vapor	2d - Excavate TCE to REL, ERD, PCB-containing caulk removal, MNA to west of existing AS/SVE, institutional controls for vapor	
Brief Description	Excavate soil that exceeds the CUL for TCE and is above 15 feet bgs. Perform injection to promote ERD. Remove PCB-containing caulk near MW-16A and MW-34A. Expand existing AS/SVE system to the west. Establish institutional controls for vapor intrusion.	Excavate soil that exceeds the REL for TCE (5 µg/L) and is above 15 feet bgs. Perform injection to promote ERD. Remove PCB-containing caulk near MW-16A and MW-34A. Expand existing AS/SVE system to the west. Establish institutional controls for vapor intrusion.	Excavate soil that exceeds the REL for TCE (5 µg/L) and is above 15 feet bgs. Perform groundwater monitoring on all the existing monitoring wells for 30-year period. Remove PCB-containing caulk near MW-16A and MW-34A. Expand existing AS/SVE system to the west. Establish institutional controls for vapor intrusion.	Excavate soil that exceeds the REL for TCE (5 µg/L) and is above 15 feet bgs. Perform injection to promote ERD. Remove PCB-containing caulk near MW-16A and MW-34A. Establish institutional controls for vapor intrusion. AS/SVE system operates but is not expanded.	
Permanent to maximum extent practicable? [disproportionate cost analysis, WAC 173-340-360(3)]					
Benefit evaluation					
Overall protectiveness	30%	8 Contaminated materials are removed from site, halogenated VOCs are destroyed due to ERD, and VC levels in groundwater are reduced due to AS/SVE expansion. Workers and public may be affected by large movement of soils containing volatiles.	6.5 Contaminated materials are removed from site, halogenated VOCs destruction is accelerated due to ERD, and VC levels in groundwater are reduced due to AS/SVE expansion. Some contaminated materials remain on site which exceed the CUL.	5 Contaminated materials are removed from site, monitored natural attenuation for residual contaminants, and VC levels in groundwater are reduced due to AS/SVE expansion.	3.5 Contaminated materials are removed from site, VOC destruction is accelerated by ERD, and VC levels in groundwater are reduced due to AS/SVE.
Permanence	20%	8 Contaminants are disposed of at a landfill. Residual contaminants are destroyed by ERD or removed via AS/SVE.	6 Contaminants are disposed of at a landfill (less disposal than Alternative 2a). Residual contaminants are destroyed by ERD or removed via AS/SVE.	4 Contaminants are disposed of at a landfill (less disposal than Alternative 2a). Residual contaminants are converted during MNA or removed via AS/SVE.	5 Contaminants are disposed of at a landfill (less disposal than Alternative 2a). Residual contaminants are destroyed by ERD or removed via AS/SVE.
Effectiveness over long-term	20%	9 Most contaminated materials are removed. Removal of remaining contaminants is expedited due to AS/SVE expansion and ERD.	7 Contaminated materials are removed, although less than Alternative 2a. Removal of remaining contaminants is expedited due to AS/SVE expansion and ERD.	5 Contaminated materials are removed. Removal of contaminants near the LDW is expedited due to AS/SVE expansion. Removal of residual contaminants occurs via MNA.	6 Contaminated materials are removed. Removal of contaminants near the LDW is expedited due to existing AS/SVE. Removal of remaining contaminants is expedited due to AS/SVE and ERD.
Management of short-term risks	10%	3 Large portions of contaminated soils are exposed, transported, and disposed off-site.	5 Moderate portions of contaminated soils are exposed, transported, and disposed off-site.	5 Moderate portions of contaminated soils are exposed, transported, and disposed off-site.	3 Moderate portions of contaminated soils are exposed, transported, and disposed off-site. Vinyl chloride may increase during ERD and therefore this remedy may not be sufficient in the short term.
Technical and administrative implementability	10%	4 Technology is proven or has been demonstrated on surrounding sites. However, excavation and ERD areas are large.	6 Technology is proven or has been demonstrated on surrounding sites. However, ERD area is large.	8 Technology is proven or has been demonstrated on surrounding sites.	7 Technology is proven or has been demonstrated on surrounding sites. However, ERD area is large.
Consideration of public concerns	10%	5 Visible impacts would be sizeable and large quantity of excavated contaminated materials are transported through the surrounding neighborhood. However, the surrounding area is industrial.	7 Visible impacts would be present in select areas; however, the surrounding area is industrial and excavated quantities would not be exceptional.	7 Visible impacts would be present in select areas; however, the surrounding area is industrial and excavated quantities would not be exceptional.	7 Visible impacts would be present in select areas; however, the surrounding area is industrial and excavated quantities would not be exceptional.
Overall weighted benefit score	100%	7.0	6.4	5.3	5.0

Table C-2B - Evaluation of Other Requirements - Groundwater

Alternative No.	2a - Excavate TCE to CUL, ERD, PCB-containing caulk removal, AS/SVE expansion, institutional controls for vapor	2b - Excavate TCE to REL, ERD, PCB-containing caulk removal, AS/SVE expansion, institutional controls for vapor	2c - Excavate TCE to REL, MNA across TCE plume, PCB-containing caulk removal, AS/SVE expansion, institutional controls for vapor	2d - Excavate TCE to REL, ERD, PCB-containing caulk removal, MNA to west of existing AS/SVE, institutional controls for vapor
Brief Description	Excavate soil that exceeds the CUL for TCE and is above 15 feet bgs. Perform injection to promote ERD. Remove PCB-containing caulk near MW-16A and MW-34A. Expand existing AS/SVE system to the west. Establish institutional controls for vapor intrusion.	Excavate soil that exceeds the REL for TCE (5 µg/L) and is above 15 feet bgs. Perform injection to promote ERD. Remove PCB-containing caulk near MW-16A and MW-34A. Expand existing AS/SVE system to the west. Establish institutional controls for vapor intrusion.	Excavate soil that exceeds the REL for TCE (5 µg/L) and is above 15 feet bgs. Perform groundwater monitoring on all the existing monitoring wells for 30-year period. Remove PCB-containing caulk near MW-16A and MW-34A. Expand existing AS/SVE system to the west. Establish institutional controls for vapor intrusion.	Excavate soil that exceeds the REL for TCE (5 µg/L) and is above 15 feet bgs. Perform injection to promote ERD. Remove PCB-containing caulk near MW-16A and MW-34A. Establish institutional controls for vapor intrusion. AS/SVE system operates but is not expanded.
Cost evaluation (\$M)				
Initial capital cost to construct	18.04	3.43	0.78	3.29
Annual O&M cost	0.66	0.66	0.42	0.34
Estimated restoration time frame [years]	10	10	20	20
O&M cost over restoration timeframe	6.61	6.61	8.43	6.84
Total cost over life of remedy	24.65	10.04	9.22	10.12
Ratio of benefit/cost	0.28	0.63	0.58	0.49

NOTES:
AS/SVE = air sparging/soil vapor extraction system; ERD = enhanced reductive dechlorination; µg/L = microgram per liter; MNA = monitored natural attenuation; PCB = polychlorinated biphenyl; REL = remediation level;
TCE = trichloroethylene; VC = vinyl chloride

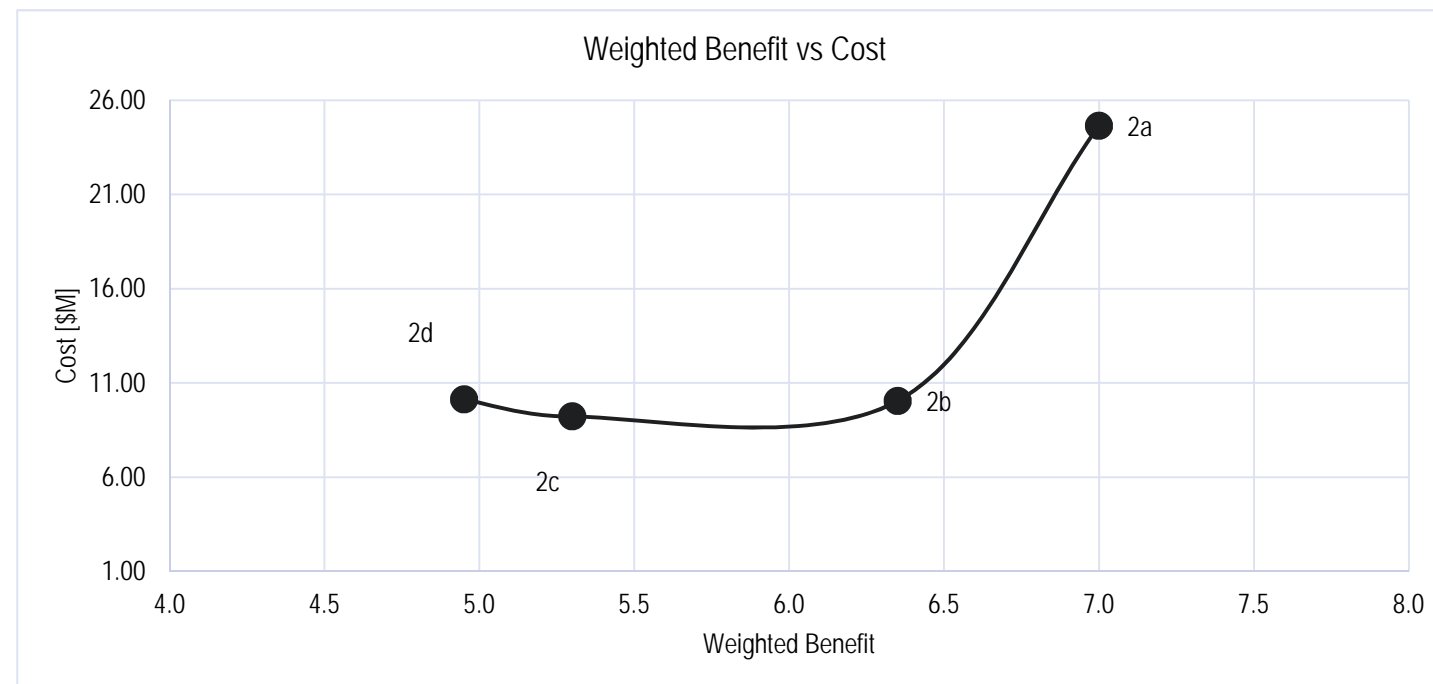

Table C-2C - Cost Breakdown for Groundwater Alternatives

Alternative No.	2a - Excavate TCE to CUL, ERD, PCB-containing caulk removal, AS/SVE expansion, institutional controls for vapor	2b - Excavate TCE to REL, ERD, PCB-containing caulk removal, AS/SVE expansion, institutional controls for vapor	2c - Excavate TCE to REL, MNA across TCE plume, PCB-containing caulk removal, AS/SVE expansion, institutional controls for vapor	2d - Excavate TCE to REL, ERD, PCB-containing caulk removal, MNA to west of existing AS/SVE, institutional controls for vapor
Brief Description	Excavate soil that exceeds the CUL for TCE and is above 15 feet bgs. Perform injection to promote ERD. Remove PCB-containing caulk near MW-16A and MW-34A. Expand existing AS/SVE system to the west. Establish institutional controls for vapor intrusion.	Excavate soil that exceeds the REL for TCE (5 µg/L) and is above 15 feet bgs. Perform injection to promote ERD. Remove PCB-containing caulk near MW-16A and MW-34A. Expand existing AS/SVE system to the west. Establish institutional controls for vapor intrusion.	Excavate soil that exceeds the REL for TCE (5 µg/L) and is above 15 feet bgs. Perform groundwater monitoring on all the existing monitoring wells for 30-year period. Remove PCB-containing caulk near MW-16A and MW-34A. Expand existing AS/SVE system to the west. Establish institutional controls for vapor intrusion.	Excavate soil that exceeds the REL for TCE (5 µg/L) and is above 15 feet bgs. Perform injection to promote ERD. Remove PCB-containing caulk near MW-16A and MW-34A. Establish institutional controls for vapor intrusion. AS/SVE system operates but is not expanded.
Capital Costs				
Capital Direct Cost (Installed)				
Mob/Demob	\$1,000	\$99	\$50	\$97
Site Survey	\$10	\$15	\$15	\$15
Concrete breaking	\$842	\$42	\$42	\$26
Shoring system				
Excavation of solid waste	\$533	\$12	\$12	\$10
Off-site disposal of solid waste excavated	\$3,680	\$125	\$125	\$97
Borrowed clean fill	\$1,333	\$29	\$29	\$24
Surface Restoration/capping	\$3,078	\$29	\$29	\$29
AS Well Driller/Installation	\$30	\$30	\$30	
Injection Event	\$860 157 points, 8 per day per event, 3 events	\$860 157 points, 8 per day per event, 3 events		\$860 157 points, 8 per day per event, 3 events
Initial Injection Event				
Plumbing	\$25	\$25	\$25	
Treatment equipment	\$10	\$10	\$10	
Water disposal/ treatment				
Catch basin/filter installation				
Sampling/analysis for the compliance measure	\$138	\$40	\$40	\$40
Installing new wells	\$150	\$10	\$10	\$10
Reagent	\$934	\$934		\$934
Well Abandonment	\$27	\$1	\$1	\$1
Capital Indirect Costs				
Engineering/Oversite/Documentation	\$3,795	\$678	\$170	\$658
Ecology Oversight	\$50	\$50	\$70	\$70
Construction QA and Management	\$140	\$140	\$17	\$123
Closure Documentation	\$49	\$49	\$49	\$49
Tukwila Business Permit	\$10	\$10	\$10	\$10
Combined Tukwila Taxes and Fees (10% capital costs, 2% Labor)	\$1,346	\$244	\$48	\$232
Total Capital Cost	\$18,040	\$3,433	\$782	\$3,286

Table C-2C - Cost Breakdown for Groundwater Alternatives

Alternative No.	2a - Excavate TCE to CUL, ERD, PCB-containing caulk removal, AS/SVE expansion, institutional controls for vapor	2b - Excavate TCE to REL, ERD, PCB-containing caulk removal, AS/SVE expansion, institutional controls for vapor	2c - Excavate TCE to REL, MNA across TCE plume, PCB-containing caulk removal, AS/SVE expansion, institutional controls for vapor	2d - Excavate TCE to REL, ERD, PCB-containing caulk removal, MNA to west of existing AS/SVE, institutional controls for vapor
Brief Description	Excavate soil that exceeds the CUL for TCE and is above 15 feet bgs. Perform injection to promote ERD. Remove PCB-containing caulk near MW-16A and MW-34A. Expand existing AS/SVE system to the west. Establish institutional controls for vapor intrusion.	Excavate soil that exceeds the REL for TCE (5 µg/L) and is above 15 feet bgs. Perform injection to promote ERD. Remove PCB-containing caulk near MW-16A and MW-34A. Expand existing AS/SVE system to the west. Establish institutional controls for vapor intrusion.	Excavate soil that exceeds the REL for TCE (5 µg/L) and is above 15 feet bgs. Perform groundwater monitoring on all the existing monitoring wells for 30-year period. Remove PCB-containing caulk near MW-16A and MW-34A. Expand existing AS/SVE system to the west. Establish institutional controls for vapor intrusion.	Excavate soil that exceeds the REL for TCE (5 µg/L) and is above 15 feet bgs. Perform injection to promote ERD. Remove PCB-containing caulk near MW-16A and MW-34A. Establish institutional controls for vapor intrusion. AS/SVE system operates but is not expanded.
Periodic Costs				
Semi-Annual Vapor Control Maintenance	\$266 10 year total	\$266 10 year total	\$300 15 year total	\$335 20 year total
Cap Inspection/Maintenance Costs- Institutional Control	\$10	\$10	\$10	\$10
Annual Sampling/Monitoring/Reporting*	\$5,160 20 year total	\$5,160 10 year at TCE plume, 20 years west of AS/SVE (20 total)	\$6,450 30 year at TCE plume, 20 years west of AS/SVE (30 total)	\$4,952 10 year at TCE plume, 30 years west of AS/SVE (30 total)
Project Management/Seal Inspection	\$104	\$104	\$104	
5-Year Reporting	\$936 4 reports	\$936 4 reports	\$1,404 6 reports	\$1,404 6 reports
Combined Sales Tax for Tukwila, Washington (10% capital costs, 2% Labor)	\$130	\$130	\$165	\$134
Total Periodic Cost: (@2019)	\$6,606	\$6,606	\$8,434	\$6,835
Total Cleanup Cost (Capital + Periodic Cost): @ 2019yr				
Average	\$24,646	\$10,039	\$9,216	\$10,121
Low End (-30%)	\$17,252	\$7,027	\$6,451	\$7,085
High End (+50%)	\$36,969	\$15,058	\$13,824	\$15,182

NOTES:

*Annual stormwater maintenance costs are incurred by owner/tenant and not included within this cost estimate.

Costs do not include net present worth adjustment.

Costs are in thousands of dollars.

AS/SVE = air sparge/soil vapor extraction; CUL = preliminary cleanup level; ERD = enhanced reductive dechlorination; MNA = monitored natural attenuation; PCB = polychlorinated biphenyl; REL = remediation level; TCE = trichloroethylene; VC = vinyl chloride

Table C-3A - Evaluation of Threshold Requirements - Northwest Area

Preliminary Alternative	Protects human health and the environment	Complies with cleanup standards	Complies with applicable state and federal laws	Provides for compliance monitoring	Carried Forward
No action	No	No	No	No	No
ISCO with MNA	Yes	Yes	Yes	Yes	Yes
Pump and treat	Yes	Yes	Yes	Yes	Yes
Permeable reactive barrier	Yes	Yes	Yes	Yes	Yes
Cap and institutional controls	No	No	Yes	Yes	No
MNA only	No	No	Yes	Yes	No

NOTES:

ISCO = in situ chemical oxidation; MNA = monitored natural attenuation

Table C-3B - Evaluation of Other Requirements - Northwest Area

Alternative No.	3a - Pump and treat	3b - Permeable reactive barrier	3c - ISCO with MNA
Brief Description	Install groundwater removal and treatment system. Requires installation of 6 extraction wells. Consists of pumps, filters, and sparging tank. Discharges to sanitary sewer.	Install 200 feet of permeable reactive barrier along the north boundary of the northwest area that jogs southwards for 5 feet at the far west that treats water as it moves through.	Inject ISCO reagent into northwest corner 2 times a years for 3 years for groundwater remediation.
Considers public concerns?			
Considers public concerns?	Yes	Yes	Yes
Reasonable restoration time frame? [WAC 173-340-360(4)]			
Estimated restoration time frame (years)	15	15	4
Toxicity of COCs	High Gasoline and VC	High Gasoline and VC	High Gasoline and VC
Risk to human health and environment during remedy	Low Workers will have low exposures	Low Workers will have low exposures	Low Workers will have low exposures
Has natural attenuation been documented to occur on site?	Yes Not applicable to this alternative	Yes Not applicable to this alternative	Yes MNA used in this alternative
Practical to achieve shorter restoration time frame? (includes consideration of natural attenuation)	Yes ISCO is expected to be faster	Yes ISCO is expected to be faster	No --
Consistent with current use of site, surrounding area, & resources?	Yes Property is vacant. Activities will not affect surrounding businesses.	Yes Property is vacant. Activities will not affect surrounding businesses.	Yes Property is vacant. Activities will not affect surrounding businesses.
Consistent with planned future use of site, surrounding area, & resources?	Yes Removes sources to surrounding areas	Yes Removes sources to surrounding areas	Yes Removes sources to surrounding areas
Availability of alternate water supply	Not Applicable Alternate water supply not needed	Not Applicable Alternate water supply not needed	Not Applicable Alternate water supply not needed
Effectiveness and reliability of institutional controls	Yes Maintain pavement	Yes Maintain pavement	Yes Maintain pavement
Ability to monitor and control chemical migration from site	Yes Monitored using wells. Chemical migration limited using extraction wells.	Yes Monitored using wells. Chemical migration limited using permeable reactive barrier.	Yes Monitored using wells.

Table C-3B - Evaluation of Other Requirements - Northwest Area

Alternative No.	3a - Pump and treat	3b - Permeable reactive barrier	3c - ISCO with MNA
Brief Description	Install groundwater removal and treatment system. Requires installation of 6 extraction wells. Consists of pumps, filters, and sparging tank. Discharges to sanitary sewer.	Install 200 feet of permeable reactive barrier along the north boundary of the northwest area that jogs southwards for 5 feet at the far west that treats water as it moves through.	Inject ISCO reagent into northwest corner 2 times a years for 3 years for groundwater remediation.
Permanent to maximum extent practicable? [disproportionate cost analysis, WAC 173-340-360(3)]			
Benefit evaluation			
Overall protectiveness 30%	5 Contaminants are removed from the groundwater, however, contaminants absorbed to soil remain and will slowly degrade.	6 Contaminants are retained on the permeable wall but still will take time to break down naturally.	8 Contaminants are destroyed in the groundwater.
Permanence 20%	8 Contaminants are removed from the groundwater, however, contaminants which are absorbed to soil remain.	8 Contaminants are retained on the wall and degrade before migrating offsite.	7 Contaminants are destroyed in the groundwater. Contaminant concentration rebound may occur.
Effectiveness over long-term 20%	4 Contaminants are removed from the groundwater. However, diminishing returns are expected over the long term.	4 Contaminants are retained on the permeable wall but still will take time to break down naturally.	9 Contaminants are destroyed in the groundwater.
Management of short-term risks 10%	5 Lower short term risks.	3 Groundwater gradient/flow uncertain in the NW corner.	3 Reagents will need careful management to prevent offsite movement. Contaminant concentration rebound may occur.
Technical and administrative implementability 10%	3 Implementability is low for this area, because of limited accessibility and existing structures.	3 Implementability is low for this area, because of limited accessibility and existing structures.	5 Implementability is low for this area, but higher than other alternatives, because of limited accessibility and existing structures.
Consideration of public concerns 10%	8 Public concerns are relatively low, because groundwater remediation would be occurring ex-situ.	8 Public concerns are relatively low, because groundwater remediation would be occurring in-situ.	5 Groundwater remediation would be occurring in-situ, but the public may be concerned of reagents migrating to the Duwamish.
Overall weighted benefit score 100%	5.5	5.6	6.9
Cost evaluation (\$M)			
Initial capital cost to construct	0.37	1.58	1.77
Annual O&M cost	0.41	0.12	0.21
Estimated restoration time frame [years]	15	15	4
O&M cost over restoration timeframe	6.17	1.73	0.84
Total cost over life of remedy	6.54	3.31	2.60
Ratio of benefit/cost	0.84	1.69	2.65

NOTES:

ISCO = in situ chemical oxidation; MNA = monitored natural attenuation; PCB = polychlorinated biphenyl;

TCE = trichloroethylene; VC = vinyl chloride

Table C-3B - Evaluation of Other Requirements - Northwest Area

Alternative No.	3a - Pump and treat	3b - Permeable reactive barrier	3c - ISCO with MNA
Brief Description	Install groundwater removal and treatment system. Requires installation of 6 extraction wells. Consists of pumps, filters, and sparging tank. Discharges to sanitary sewer.	Install 200 feet of permeable reactive barrier along the north boundary of the northwest area that jogs southwards for 5 feet at the far west that treats water as it moves through.	Inject ISCO reagent into northwest corner 2 times a years for 3 years for groundwater remediation.

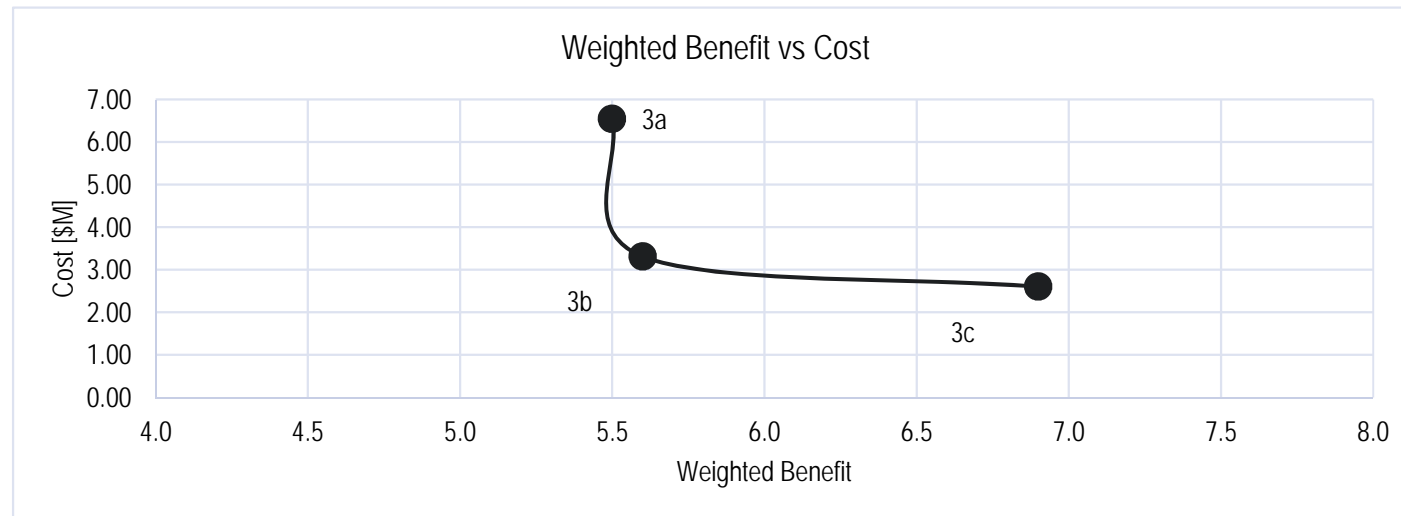

Table C-3C - Cost Breakdown for Northwest Area Alternatives

Alternative No.	3a - Pump and treat	3b - Permeable reactive barrier	3c - ISCO with MNA
Brief Description	Install groundwater removal and treatment system. Requires installation of 6 extraction wells. Consists of pumps, filters, and sparging tank. Discharges to sanitary sewer.	Install 200 feet of permeable reactive barrier along the north boundary of the northwest area that jogs southwards for 5 feet at the far west that treats water as it moves through.	Inject ISCO reagent into northwest corner 2 times a years for 3 years for groundwater remediation.
Capital Costs			
Capital Direct Cost (Installed)			
Mob/Demob	\$6		\$6
Site Survey			
Concrete breaking			
Shoring system			
Excavation of solid waste			
Off-site disposal of solid waste excavated			
Borrowed clean fill			
Surface Restoration/capping			
Injection Event		\$959 See Note 1	\$352 17 points, 6 per day per event, 6 events
Trenching/piping	\$50		
Plumbing	\$25		
Treatment equipment	\$95		
Water disposal/ treatment			
Catch basin/filter installation			
Sampling/analysis for the compliance measure			
Installing new wells	\$40	\$12	\$12
Reagent			\$740
Well Abandonment			\$3
Capital Indirect Costs			
Engineering/Oversite/Documentation	\$71	\$291	\$364
Ecology Oversight	\$50	\$50	\$20
Construction QA and Management		\$150	\$136
Closure Documentation			
Tukwila Business Permit	\$10	\$10	\$10
Combined Tukwila Taxes and Fees (10% capital costs, 2% Labor)	\$24	\$107	\$122
Total Capital Cost	\$371	\$1,579	\$1,765

Table C-3C - Cost Breakdown for Northwest Area Alternatives

Alternative No.	3a - Pump and treat	3b - Permeable reactive barrier	3c - ISCO with MNA
Brief Description	Install groundwater removal and treatment system. Requires installation of 6 extraction wells. Consists of pumps, filters, and sparging tank. Discharges to sanitary sewer.	Install 200 feet of permeable reactive barrier along the north boundary of the northwest area that jogs southwards for 5 feet at the far west that treats water as it moves through.	Inject ISCO reagent into northwest corner 2 times a years for 3 years for groundwater remediation.
Periodic Costs			
Water disposal	\$4,500 Sanitary sewer disposal (15 years)		
Annual Sampling/Monitoring/Reporting*	\$900 15 years	\$1,050 15 years @ \$70K/year	\$200
Project Management	\$50	\$50	\$20
Reporting	\$600	\$600	\$600
Combined Sales Tax for Tukwila, Washington (10% capital costs, 2% Labor)	\$121	\$34	\$16
Total Periodic Cost: (@2019)	\$6,171	\$1,734	\$836
Total Cleanup Cost (Capital + Periodic Cost): @ 2019yr			
Average	\$6,542	\$3,313	\$2,601
Low End (-30%)	\$4,579	\$2,319	\$1,821
High End (+50%)	\$9,813	\$4,970	\$3,901

NOTES:

1 Costs derived from a similar project completed by Clearcreek Contractors. Previous project was a 700 feet long PRB with ZVI mixed with sand. The PRB was 27ft deep and 12-15ft wide. The PRB was installed using a bio-slurry due to groundwater. The PRB cost \$1.6M for materials and labor (includes \$625K for ZVI and sand). This equates to 3.702E-4 \$M per cubic yard of PRB.

*Annual stormwater maintenance costs are incurred by owner/tenant and not included within this cost estimate.

Costs do not include net present worth adjustment.

Costs are in thousands of dollars.

AS/SVE = air sparge/soil vapor extraction; ISCO = in situ chemical oxidation; MNA = monitored natural attenuation; PRB = permeable reactive barrier; TCE = trichloroethylene; ZVI = zero valent iron