



FINAL

28 NOVEMBER 2018

OPERATION AND MAINTENANCE PLAN

Operable Units 1 and 2

CONTRACT NO. N44255-14-D-9011, TASK ORDER N4425518F4214

Naval Base Kitsap

Keyport, Washington

Department of the Navy

Naval Facilities Engineering Command Northwest

1101 Tautog Circle, Suite 203

Silverdale, WA 98315-1101



CONTRACT NO. N44255-14-D-9011
LTM/OM/ TASK ORDER N4425518F4214

FINAL
OPERATION AND MAINTENANCE PLAN

OPERABLE UNITS 1 AND 2

NAVAL BASE KITSAP KEYPORT
KEYPORT, WASHINGTON

NOVEMBER 28, 2018

SEALASKA ENVIRONMENTAL SERVICES, LLC
POULSBO, WASHINGTON

Prepared by:

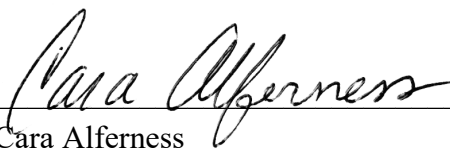

Cara Alferness

Alternate Task Order Manager / PQCM

Reviewed by:

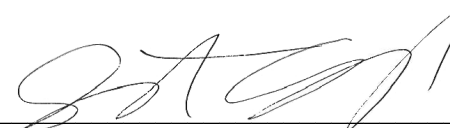

Scott Elkind, PE, PMP

Task Order Manager

CONTENTS

1. INTRODUCTION	1-1
2. OPERABLE UNIT 1	2-1
2.1 SITE DESCRIPTION AND HISTORY	2-1
2.2 IMPLEMENTATION OF PHYTOREMEDIATION	2-1
2.2.1 ROD Requirements for Phytoremediation	2-2
2.2.2 Plantation Facilities	2-3
2.2.3 Phytoremediation Monitoring Objectives	2-5
2.3 TIDE GATE REMEDY	2-6
2.3.1 Sediment Removal and Tide Gate Replacement	2-7
2.3.2 Tide Gate Operating Principles	2-7
2.4 PLANTATION LONG-TERM OPERATION AND MAINTENANCE	2-8
2.4.1 Inspections	2-8
2.4.2 Tree Nurturing and Damage Response Activities	2-13
2.4.3 Reporting and Documentation	2-20
2.5 PLANTATION FACILITIES MAINTENANCE	2-20
2.5.1 Piping Winterization	2-20
2.5.2 Reactivating Irrigation	2-20
2.5.3 Decommissioning Irrigation System	2-21
2.6 TIDE GATE INSPECTION AND MAINTENANCE	2-28
2.6.1 Sediment Removal and Tide Gate Replacement	2-28
2.6.2 Tide Gate Operating Principles	2-28
2.6.3 Inspection Requirements	2-29
2.6.4 Maintenance Requirements	2-30
2.6.5 Tide Gate Maintenance and Monitoring Schedule	2-31
2.6.6 Additional Information on Repair Activities	2-32
2.7 OU1 AREA 1 WELL RESURVEY	2-32
2.7.1 Mobilization	2-32
2.7.2 Well Resurvey	2-32
3. OPERABLE UNIT 2 AREA 8	3-1
3.1 SITE DESCRIPTION AND HISTORY	3-1
3.2 OU 2 AREA 8 WELL REDEVELOPMENT	3-2
3.2.1 Well Selection for Redevelopment	3-2
3.2.2 Mobilization	3-2
3.2.3 Well Redevelopment	3-3
4. MATERIALS AND WASTE MANAGEMENT	4-1
4.1 MATERIALS MANAGEMENT	4-1
4.2 WASTE MANAGEMENT	4-1
5. PROJECT SCHEDULE	5-1
6. DOCUMENTATION AND REPORTING	6-1

CONTENTS (CONTINUED)

7. HEALTH AND SAFETY	7-1
8. REFERENCES	8-1

APPENDICES

APPENDIX A	TREE PLANTATION LAYOUT DIAGRAMS
APPENDIX B	FIELD PROCEDURES AND FORMS
APPENDIX C	PHOTOGRAPHS OF THREATS TO TREE HEALTH
APPENDIX D	TIDE GATE OPERATION AND MAINTENANCE MANUAL AND DRAWINGS
APPENDIX E	RESPONSES TO REGULATORY AGENCY COMMENTS ON DRAFT FINAL OPERATION AND MAINTENANCE PLAN

FIGURES

Figure 1-1.	NBK Keyport Vicinity Map	1-2
Figure 1-2.	Location of Phytoremediation Plantations	1-3
Figure 2-1.	Irrigation System Process Flow Diagram Following Partial Decommissioning	2-23
Figure 2-2.	Layout of North Plantation Shed Irrigation System – West Wall	2-26
Figure 2-3.	Layout of North Plantation Shed Irrigation System Piping – North Wall	2-27
Figure 2-4.	Monitoring Wells to be Surveyed, OU 1, Area 1	2-34
Figure 3-1.	Location of Monitoring Wells to be Redeveloped, OU 2, Area 8	3-5

TABLES

Table 2-1.	Reusable Major Components of Irrigation System	2-25
Table 2-2.	Monitoring Wells to be Surveyed	2-33
Table 3-1.	Area 8 Monitoring Well Details	3-4
Table 5-1.	Estimated Inspection and Maintenance Schedule for Phytoremediation and Tide Gate O&M	5-2

ACRONYMS AND ABBREVIATIONS

ARAR	applicable or relevant and appropriate requirement
ASIL	acceptable source impact level
BGS	below ground surface
BOSC	base operations contractor
CFR	Code of Federal Regulations
CHMI	Contractor's Hazardous Material Inventory
COC	contaminant of concern
CPQC	Contractor Production/Quality Control
CRA	Contingent Remedial Action
DCN	Design Change Notice
Ecology	Washington State Department of Ecology
EPA	U.S. Environmental Protection Agency
FCR	Field Change Request
IC	Institutional Controls
LTM	Long-Term Monitoring
MMA	Management and Monitoring Approach
MSL	mean sea level
NAVFAC	Naval Facilities Engineering Command
Navy	U.S. Department of the Navy
NBK	Naval Base Kitsap
NCR	Nonconformance Report
NTR	Navy Technical Representative
NTU	nephelometric turbidity units
O&M	operation and maintenance
OU	Operable Unit
PCB	polychlorinated biphenyl
PPE	personal protective equipment
PSCAA	Puget Sound Clean Air Agency
RI/FS	remedial investigation/feasibility study

ACRONYMS AND ABBREVIATIONS (CONTINUED)

ROD	Record of Decision
RPM	Remedial Project Manager
SAP	Sampling and Analysis Plan
Sealaska	Sealaska Environmental Services, LLC
SOP	standard operating procedure
SSHO	Site Safety & Health Officer
SSHP	Site Safety and Health Plan
TCE	trichloroethene
TOM	Task Order Manager
USGS	U.S. Geological Survey
UST	underground storage tank
VCR	video cassette recorder
VOC	volatile organic compound

1. INTRODUCTION

This document constitutes the long-term operation and maintenance (O&M) plan for phytoremediation and the tide gate system at Operable Unit (OU) 1, and for other maintenance activities at OU 1 and OU 2 during 2018, at Naval Base Kitsap (NBK) Keyport, in Keyport, Washington (Figure 1-1). This plan was prepared under U.S. Department of the Navy (Navy) Contract No. N44255-14-D-9011 as part of Task Order 18F4214 for Naval Facilities Engineering Command (NAVFAC) Northwest.

NBK Keyport occupies 340 acres (including tidelands) adjacent to the town of Keyport in Kitsap County, Washington, on a small peninsula in the central portion of Puget Sound. The peninsula is bordered by Dogfish Bay to the west and northwest, Liberty Bay to the north and northeast, and Port Orchard Bay to the east and southeast (refer to Figure 1-1). The topography of the base rises gently from the shoreline to an average elevation of 25 to 30 feet above mean sea level (msl), and then rises steeply at the southeast corner of the base to approximately 130 feet above msl.

Other marine or brackish surface water bodies on and near the base include tide flats, a marsh, and a shallow lagoon.

This O&M Plan includes recommendations from the Annual O&M Reports (Navy 2016, 2017a, and 2018a) and Area 1 Long-Term Monitoring (LTM) Reports (Navy 2017b and 2018b), along with the Fourth Five-Year Review (Navy 2015).

This O&M plan is part of a set of plans which include the Management and Monitoring Approach (MMA) Sampling and Analysis Plan (SAP; Navy 2018c), the Institutional Controls (IC) Plan (Navy 2017c), and the Contingent Remedial Action (CRA) Plan (Navy 2012).

This plan also includes activities beyond typical annual O&M activities planned to be completed in 2018 at both OU 1 and at OU 2 Area 8, including:

- Tree removal at OU 1
- A well survey at OU 1
- Well redevelopment at OU 2, Area 8

1-2

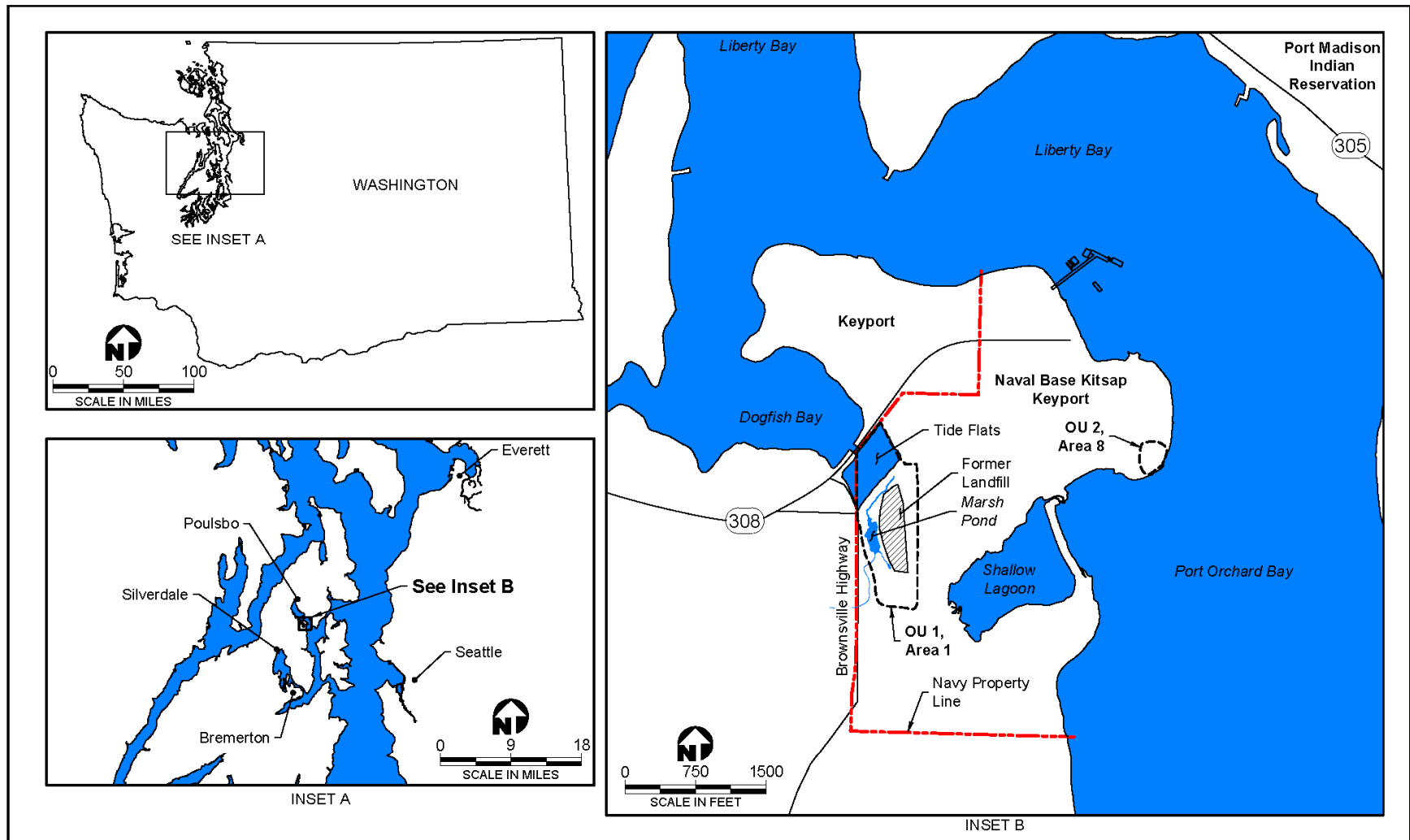

<p>U.S. NAVY SEALASKA</p>	<p>Figure 1-1 NBK Keyport Vicinity Map</p>	<p>NBK Keyport O&M Plan Update</p>
----------------------------------	--	---

C:\USERS\WALTER.BOWLES\DOCUMENTS\KEYPORT\18F4214\O&M\NATIVE\FIG 1-1.DWG
 Mod: 7/11/2018 9:07:14 AM Plotted: 7/11/2018 9:07:20 AM By: WALTER.BOWLES CTB: SES-MAIN-COLOR.CTB

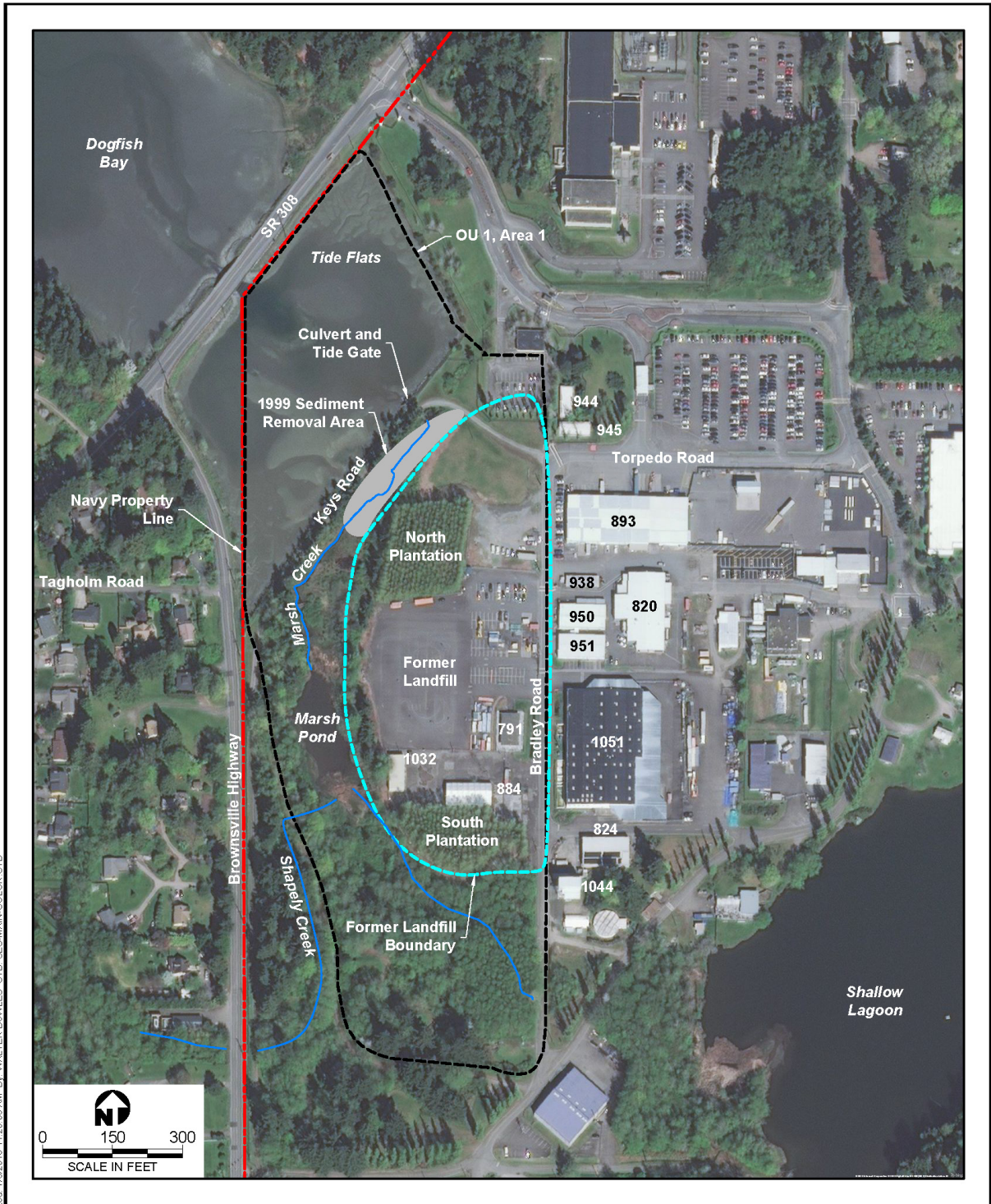

C:\USER\WALTER.BOWLES\DOCUMENTS\KEYPORT\18F4214\08\MM\NATIVE\FIG 1-2.DWG
 Mod: 7/9/2018 10:28:25 AM Plotted: 7/9/2018 11:20:09 AM BY: WALTER.BOWLES CTB SES-MAIN-COL-OR-CTB

<p>U.S. NAVY SEALASKA</p>	<p>U.S. NAVY SEALASKA</p>	<p>Figure 1-2 Location of Phytoremediation Plantations</p>	<p>NBK Keyport O&M Plan Update</p>
----------------------------------	----------------------------------	--	---

2. OPERABLE UNIT 1

2.1 SITE DESCRIPTION AND HISTORY

The OU 1 portion of NBK Keyport consists of the former base landfill, approximately 9 acres in size, and the surrounding potentially contaminated environment. The landfill area was formerly marshland, and a portion of the marsh remains on the western and southern sides of the landfill. Freshwater bodies in the vicinity of the landfill include two creeks that flow into and through the marsh, discharging to the tide flats through a culvert and tide gate (refer to Figure 1-2).

A detailed site description, along with site history, geology, remedial action objectives, and selected remedies, is provided in the MMA SAP (Navy 2018c).

OU 1 included phytoremediation plantations and a tide-gate system as two major components of the selected remedy. The two types of LTM being conducted at OU 1 include:

- Monitoring of phytoremediation performance at the two plantations
- Site-wide risk and compliance monitoring

The tide-gate monitoring and O&M at OU 1 are part of the remedy protection for the site. A functioning tide gate prevents tidal inundation of the wetlands and landfill soils, which supports the remedial action objective of preventing contaminated groundwater from entering site surface water as well as protecting the landfill banks from erosion.

Implementation of the phytoremediation and the tide-gate components of the selected remedy are described in the following sections.

2.2 IMPLEMENTATION OF PHYTOREMEDIATION

The goal of phytoremediation is to use hybrid poplar trees to remove and treat groundwater contaminated with volatile organic compounds (VOCs), thus reducing the long-term potential for VOC migration. The OU 1 phytoremediation program, which was implemented in accordance with the OU 1 Record of Decision (ROD) in spring 1999, uses two approximately 1-acre plantations (north and south) located at two source areas containing high VOC concentrations (hot spots) that were identified during the remedial investigation/feasibility study (RI/FS).

2.2.1 ROD Requirements for Phytoremediation

Design criteria specified in the ROD (Navy, EPA, and Ecology 1998) for implementation of phytoremediation at OU 1 include planting density with consideration of water uptake by poplar trees to accomplish the following:

- Avoidance of adverse dewatering of the wetlands adjacent to the landfill
- Avoidance of adverse changes in groundwater flow (such as drawing saline water from the marsh pond to the tree stands)
- Maximizing contaminant removal by the trees

The first two design criteria were met by the groundwater modeling performed by the U.S. Geological Survey (USGS), which showed that the trees would not adversely affect the wetlands, or cause adverse changes in groundwater flow (Navy 1999b). The third design criterion was met by selecting an initial planting density that maximized water usage by the young trees, and then thinning the trees as they grew to create a closed canopy of healthy, properly spaced trees.

Process monitoring and control criteria specified in the ROD included the following:

- Air quality: assessment of whether the mature stands of trees comply with action-specific regulatory requirements for air quality (e.g., acceptable source impact levels [ASILs] of the Puget Sound Clean Air Agency [PSCAA]).
- Leaf management: assessment of whether the leaves retain toxic substances that require special leaf management (e.g., can the leaves be allowed to fall and degrade naturally, or do they pose unacceptable risks to human health and the environment, and thus need to be collected for proper disposal?).
- Limb management: assessment of whether the tree limbs resulting from process O&M (e.g., pruning and thinning) retain toxic substances that require special management to comply with action-specific applicable or relevant and appropriate requirements (ARARs; e.g., land disposal regulation) and pose no unacceptable risk to human health and the environment.

The process monitoring and control criteria were met by the demonstration sampling results reported in the October–December 2001 status report (Navy 2002). Transpired air was found to contain trichloroethene (TCE) and tetrachloroethene concentrations below the applicable ASILs and, therefore, did not represent a threat to human health and the environment. The results of tree-tissue sampling indicated that all types of tree tissue were safe for disposal without restrictions, including burning in residential fireplaces.

2.2.2 Plantation Facilities

As-Built Records

The as-built configuration was described in detail in the phytoremediation closure report (Navy 1999a). Manufacturer's literature for the equipment installed was provided in the closure report as an appendix, and the report included discussions of how to operate the equipment as installed. During the fourth growing season, the water-well components of the irrigation system and the lysimeters were decommissioned. Specific changes to the piping and equipment are discussed below, under Alterations After Construction. A summary description of the existing facilities follows.

Summary Description

Two plantations of hybrid poplar trees (clonal line 15-029) were planted at OU 1 on the former landfill (Figure 1-2 and Appendix A). The plantations are referred to as the "North" and "South" Plantations. Rows of trees at each plantation are aligned roughly north to south. A buffer approximately 10-feet wide is provided between the trees and the edge of the plantations to provide access for tractors and other equipment. Each plantation was initially surrounded by 8-foot-high cyclone fencing. The fencing on the south side of the south plantation has subsequently been removed in places to allow for continued site re-characterization drilling and well installation.

Each plantation currently includes the features listed below, which are shown in as-built drawings in Appendix A and the phytoremediation closure report (Navy 1999a):

- One irrigation supply well
- Three monitoring wells within (or near) the plantation boundaries
- One background monitoring well upgradient of the plantation
- One surface water monitoring station downgradient of the plantation
- Five piezometers
- Two tap water spigots (currently non-operational)

Although currently out of use, an irrigation system provides water to both plantations. The water conditioning and supply components of the irrigation system are housed in a service shed located east of the North Plantation. Irrigation water is supplied by tap water from the base water supply. A small particulate filter is provided in the water line prior to water distribution to the plantations.

Irrigation occurs through shallow subsurface drip emitters installed in dripline tubing laid in rows parallel to the tree rows. A tap water spigot is located inside the irrigation service shed. All piping in the shed is above ground and must be drained prior to seasonal freezing conditions. Heat tape and insulation is installed on the aboveground section of the tap water piping from the base water supply up to and including the backflow preventer.

Electrical outlets are provided within the shed, along with an overhead light and exhaust fan. A digital camera and time-lapse video cassette recorder (VCR) are available to periodically record tree growth. A protective mat is located in front of the electrical panel to reduce the possibility of electric shock. The shed is equipped with a metal shelving unit and workbench.

The floor of the shed is bermed and sloped to a sump in the southwest corner. The sump pump discharges to the ground surface at the North Plantation.

Alterations After Construction

Since the publication of the phytoremediation closure report (Navy 1999a), the following alterations have been made to the piping and equipment installed at the site:

- The telephone line connection to the main control panel has been deactivated.
- A time-lapse VCR and camera have been added. The manufacturer's literature for this equipment is available onsite. A battery-operated portable television is available inside the main control panel for programming the video recorder.
- The water-well components of the irrigation system have been decommissioned and the system has been re-plumbed to use only the NBK Keyport domestic water supply system, which is operated manually.
- The lysimeters have been decommissioned.
- During paving upgrades to the parking lot situated between the plantations in fall 2002, wiring to the South Plantation was likely damaged. Additional damage to this wiring is possible stemming from the completion of the parking lot upgrades in summer 2003. The damaged wiring consists of a low-voltage wire bundle that connects the South Plantation irrigation control valves to the main control panel in the irrigation service shed. These wires were buried 12 inches below ground surface. If automatic irrigation is restarted, testing and possible replacement of this wiring would be required; however, irrigation of the south plantation can be initiated manually.

2.2.3 Phytoremediation Monitoring Objectives

The original purpose of the phytoremediation monitoring program was to assess the source removal and treatment performance of the poplar trees, the effectiveness of the trees in altering groundwater flow away from the marsh, and the potential effects the trees may have on the adjacent wetlands or on the intrinsic bioremediation conditions at the landfill source areas. The objectives for LTM include the following:

- Recognizing threats to tree health and implementing corrective actions through visual inspection
- Documenting the ability of the trees to reduce VOC concentrations by periodic sampling (detailed in the MMA SAP)

The health of the trees in the two plantations is monitored through regular inspections and observations of tree health during the growing seasons. Problems identified are corrected through horticultural or other activities. This O&M Plan only addresses monitoring of tree health and maintenance of the plantations. Details of plantation long-term operation and maintenance program are provided in Sections 2.4 and 2.5.

The conclusions of the Third and Fourth Five-Year Reviews (Navy 2010, 2015a) found that phytoremediation at the South Plantation has not been as effective as originally anticipated. COC concentrations along the southern edge of the South Plantation remain elevated. Additional subsurface investigations were conducted during the summers of 2016 and 2017 to further assess the extent of groundwater contamination and confirm the groundwater flow patterns within the aquifer beneath the South Plantation and the central landfill. Results of these investigations are still being evaluated, but initial evaluations show groundwater conditions differing from those previously interpreted.

Based on the recommendations of the 2017 O&M Report (Navy 2018a), LTM at OU 1 has been suspended until the results of the ongoing re-characterization of OU 1 have been completed and fully evaluated, the conceptual site model has been updated, and the Management and Monitoring Approach Sampling and Analysis Plan (Navy 2017e) has been revised to reflect the new understanding of groundwater conditions at OU 1.

Previous Monitoring and Maintenance

The phytoremediation monitoring and nurturing activities began immediately after completion of planting in the two plantations. During the first three growing seasons, an extensive monitoring program began that included groundwater depth measurements, groundwater and surface water sampling, irrigation system monitoring, agronomic data collection, soil sampling (first two seasons only), vadose zone water sampling (first two

seasons only), tree tissue sampling, and ambient and transpired air sampling. The monitoring program was gradually reduced during the fourth and fifth (2002-2003) growing seasons, with groundwater and surface water monitoring and groundwater depth measurements being the only monitoring activities conducted during the fifth season. The gradual reduction of the monitoring program reflected the cessation of some phytoremediation activities (e.g., irrigation using contaminated groundwater). Additionally, the maturing of trees made some monitoring tasks (especially the agronomic data collection) no longer necessary.

The phytoremediation monitoring program was reviewed and revised after the fourth growing season (2002), when the trees were deemed established and reaching maturity. The initial, active cultivation and monitoring program designed to ensure the successful establishment of the trees, was transitioned to a long-term O&M program with reduced maintenance and monitoring efforts.

In 2014 and 2015, both plantations had leaf canopies that were less full. In response to this observation, it was recommended to increase the number of inspections and maintenance events to pre-2011 levels, from four to eight events per year, to provide more frequent inspection and better maintenance of tree health. In addition, fertilization of the trees was instituted in an attempt to improve leaf canopies and overall tree health. Application of fertilizer was suspended after spring of 2017. Inspections and maintenance continue at eight events per year. Recent inspections have noted several dead standing trees in the North Plantation, as well as two live trees in winter of 2018 that were damaged by wind. One of these two trees broke at the base, the other broke leaving half of the tree still standing.

As-built drawings of the North and South Plantations are provided in Appendix A.

2.3 TIDE GATE REMEDY

Selected remedies for the site included installation and ongoing O&M of a tide gate and culvert system, to prevent inundation and possible erosion of the landfill from tidal fluctuations. The remedy also included a limited sediment removal action, which was conducted in 1998 along the marsh pond outlet channel when the new tide gate was installed (Figure 1-2). The new tide gate was field tested and commissioned in June 1999.

The upgrade of the tide gate and culvert was intended to provide greater control of tidal fluctuation in the marsh and to protect the landfill from extreme tidal events that might flood the landfill and erode the embankment at the toe of the landfill, thus potentially disturbing the buried landfill contents. A concrete culvert was installed and the tide gate upgraded in November 1999.

A closure report was prepared describing the sediment removal and tide-gate upgrade activities (Navy 1999a).

The O&M of the tide-gate system is described in Section 2.6.

2.3.1 Sediment Removal and Tide Gate Replacement

The polychlorinated biphenyl (PCB) concentrations in the marsh outlet-channel sediment were below the levels established by state regulations that would require the sediments to be actively remediated. However, the Navy decided to remove the upper layer of sediments downgradient of the landfill seep to reduce the potential for PCB concentrations to exceed the cleanup level in the future, and to reduce the likelihood of PCBs entering the Tide Flats. The sediment removal was conducted in late summer 1999. Characterization sampling was conducted first for waste profiling. As specified in the ROD, 6 inches of sediment were removed from the delineated removal area using a high-pressure vacuum truck. The sediment was vacuumed and direct-loaded into sludge boxes for disposal. Overall, roughly 75 tons of sediments were disposed of at an approved landfill.

The upgrade of the tide gate and culvert was intended to provide greater control of tidal fluctuation in the marsh and to protect the landfill from extreme tidal events that might flood the landfill and erode the embankment at the toe of the landfill, thus potentially disturbing the buried landfill contents. A concrete culvert was installed and the tide gate upgraded in November 1999.

The phytoremediation closure report describes the sediment removal and tide gate upgrade activities (Navy 1999a).

2.3.2 Tide Gate Operating Principles

The tide gate installed by the remedial action contractor is a self-regulating tide gate manufactured by Waterman Industries, Inc. Operation of the tide gate is controlled solely by the tidal cycle and tide levels; no external power or manual operation is required. The tide gate uses the “moment of force” principle, whereby the gate relies on float buoyancy and float position to achieve the weights and balances required to close and open the gate at the desired water level within its normal range of operation. The contractor made the initial adjustment on the float position based on the tidal levels at the site, and documented that the tide gate was working properly in 1999 (Navy 1999a). There have been no reports of tide gate malfunctions since commissioning. One of the two floats on the tide gate was damaged and replaced in 2015. However, the tide gate is designed to operate using only one of the two floats, so operation of the tide gate was not impeded.

Appendix D includes the O&M manual from the manufacturer, and will serve as the basis for tide gate inspection and maintenance work. Additionally, Appendix D includes the shop drawings of the Keyport tide gate showing the configuration and major components, and comments on the shop drawings from the remedial action contractor regarding the installation details and tide elevations. The following subsections describes specific inspection and maintenance requirements based on the manufacturer's recommendations, as well as field observations and findings made during the first two years (2002 through 2003) of inspection and maintenance events.

2.4 PLANTATION LONG-TERM OPERATION AND MAINTENANCE

This section describes activities to be conducted during long-term O&M of the plantations.

Upkeep and maintenance of healthy stands of poplars within the two plantations are essential to the effectiveness of the phytoremediation program. Healthy, mature stands of trees will have the greatest capacity to take up contaminated groundwater from the shallow portions of the aquifer.

This section includes details of methodology (e.g., what to look for when observing tree health). It is intended to enable the Navy to use staff who are not necessarily experts in tree horticulture to perform routine O&M activities and identify conditions that require expert consultation. A biologist, trained geologist, or trained environmental technician will conduct the inspections. A forestry specialist will be available for consultation if problems are identified.

In this section, inspections are discussed before nurturing because during long-term O&M, most nurturing activities will take place on an "as-needed" basis, triggered by an observation made during inspections.

2.4.1 Inspections

The objective of plantation inspections is specifically to recognize threats to tree health and implement corrective actions.

The inspector will fill out an inspection form during each monitoring event, and the form will also serve as a checklist to ensure that all inspection items are completed as required. The inspection form to be used is included in Appendix B.

The schedule for tree health inspection and monitoring for the two plantations is presented in Section 5, Project Schedule, and includes eight inspections per year. Monitoring will be performed during the early-to-late growing season (March and monthly May through September), once in the fall (November), and once during the dormant season (February).

To ensure healthy plantations, periodic, detailed observations of individual trees and the overall conditions of the plantations are required. Any threats to the health of individual trees or to the plantations in general must be identified and corrected before the threats can destroy or severely impact the plantations. The observer must be trained to recognize signs and symptoms that indicate threats to tree health.

The hybrid trees planted at the site are known through research studies to metabolize the COCs found at the site whenever they uptake water containing these COCs. For this reason, an effectiveness criterion established for phytoremediation at OU 1, is the maintenance of healthy stands of trees to maximize the uptake of contaminated shallow groundwater.

Signs and symptoms that represent a threat to tree health include the following:

- Physical damage from animals or humans
- Insect damage
- Water stress
- Nutrient stress
- Disease damage

For the benefit of non-expert staff, basic signs and symptoms are described below, along with the actions to be taken when these signs and symptoms are recognized.

Photographs and descriptions of common threats to tree health are available at the following websites:

- Forestry Images: The Source for Forest Health, Natural Resources and Silviculture Images Website (www.forestryimages.org/)
- University of Wisconsin-Madison, Department of Plant Pathology, Plant Disease Diagnostic Clinic Website (www.pddc.wisc.edu)
- University of Minnesota Extension Service Website (<http://www.extension.umn.edu/garden/diagnose/>)
- North Dakota State University Website (<https://www.ag.ndsu.edu/trees/tree-problems>)

Photographs of some of the signs and symptoms previously identified at OU 1 are included in Appendix C.

Forestry Expert Advising

Because of the importance of maintaining tree health, yearly inspection of the plantations by a forestry specialist may be required. The forestry specialist inspection is performed under separate contract, which will be scheduled and managed by NAVFAC Northwest, if required. If initiated, a forestry report would be submitted to NAVFAC Northwest, who will supply the results to the subcontractor performing the plantation's O&M work. A forestry expert should also be consulted regarding insect or pest damage, as described below.

Physical Damage

Physical damage from animals and/or humans is readily observable and can include the following signs and symptoms:

- Broken limbs
- Chewed or missing leaves (deer typically strip lower branches, rather than chewing portions of individual leaves as caterpillars do)
- Broken trunks and downed trees (uprooted trees can also result from high winds)
- Sudden, unexplained wilting of entire individual trees surrounded by healthy trees
- Chewed or missing bark (often from rodent damage, observable just below the soil surface; girdling around the entire trunk will kill a tree)
- Damaged bark as the result of mechanical damage due to weed control machinery
- Die-off of a previously healthy tree within 2 weeks of the application of herbicide for weed control

Actions to be taken for physical damage:

- Preventing access to the plantations by large animals and humans
- Removing habitat for rodents (such as weeds or debris on the ground surface)
- Taking additional precautions to protect trees while working on the plantations

Insect Damage

Insect damage is recognized by the following signs and symptoms:

- Dark stains running down the bark, which can indicate boring insects.
- Entire tree branches that break off at the trunk, which can indicate boring insects

- Leaves with large areas missing, which can be the result of caterpillars or other insects feeding.
- Large web systems forming on leaves, which are indicative of tent caterpillars.
- Curling of the edges of leaves, which is indicative of leaf rollers.
- Leaves with large areas turning brown and semitransparent, which can be the result of leaf miners.
- Discoloration of leaves, which can be the result of stress caused by several insects. If discoloration is observed, check the underside of the leaves for any webbing or small insects moving on the leaf surface. Discoloration of the leaves can also be the result of other plant stressors; therefore, if observed, check several possible causes.
- A mottling or change in the surface texture of the leaves, which can be an indication of bacterial or viral infection, among other issues.

Actions to be taken when insect damage is recognized:

- Determine which insect is causing the problems. If this cannot be done onsite, send photos and (if possible) leaf and insect samples to a horticultural center; such as the University of Washington or Washington State University or consult a Kitsap County Master Gardener, through the Master Gardener Program sponsored by Washington State University Extension.
- Determine the extent of the infestation and the severity of the impact on the trees. Some insects can exist at fairly high population densities and have little impact on the overall health of the trees. Other species with lower population densities can have a major adverse impact on the trees.
- Once the particular insect, and the extent and severity of the impact, has been determined, it is necessary to identify the most cost-effective action with the least impact on the plantation as a whole and that will not impact the adjacent marsh: cutting down the infected trees; cutting out the infested parts of the trees; or pesticide treatment using a pesticide designed for application near surface water. This determination should be made with the help of a professional forester (as discussed under Pest Control, below) and recommendations shall be forwarded to the Navy Remedial Project Manager (RPM) for selection and action.

Water Stress

Water stress can result from either too much or too little water being applied to the plantations and is recognized by the following signs and symptoms:

- Water deficiency:
 - If moderate, tree growth rate is stunted, and leaf density is less than normal, giving the trees a “skimpy” look. This symptom can also be caused by nutrient deficiencies; therefore, both soil moisture and nutrient level need to be evaluated.
 - If severe, the leaves lose turgor and start to wilt. This can kill the trees in a few days if the drought is severe; therefore, during excessively dry periods, the plantations should be checked weekly. During normal summers, monthly checks should be sufficient.
- Water excess:
 - Too much water can also cause trees to wilt. If the trees are wilting during the wet season, visually inspect the soil to determine if the cause of wilting is excess water.
 - Too much water causes root death, which leads to a discoloration of the leaves. Some leaves might turn red from excess anthocyanine production, a typical poplar response to stress. Leaves could also turn yellow and then brown, looking as if the tree is going into early fall senescence, at which point tree death will occur if actions are not taken to rapidly dry out the site.

Actions to be taken when water stress is recognized:

- If the trees are suffering from lack of water, the irrigation system can be turned on.
- If the trees are suffering from too much water, the drainage of the site may need to be improved by insuring that existing onsite ditches remain open. More ditches or other drainage features may also need to be added.

Nutrient Stress

Nutrient stress can occur because of either too many nutrients or too few. Nutrient stress is recognized by the following signs and symptoms:

- Too high a level of nutrients:
 - Burnt appearance of the leaves can indicate too much fertilizer
- Low levels of nutrients:
 - Poor tree growth

- Leaves smaller and fewer in number, leading to a “skimpy” appearance
- Discoloration of the leaves: leaves can be a darker, greenish blue; have a reddish tinge; show overall yellowing or yellowing of portions of the leaves (including only veins or only areas between veins)

Actions to be taken when nutrient stress is recognized:

- Collect soil samples for analysis by a county agent to determine which nutrient level is too high or too low.
- Consult a forestry specialist or county agent for the quantity and type of fertilizer to apply.
- If damage is a result of an overabundance of a particular nutrient or over-fertilization, run the irrigation system for several days to leach the excess nutrients from the soil.

Disease Damage

Damage due to disease is recognized by the following signs and symptoms:

- Overall poor tree health
- Powdery white spots on leaves
- Reddish brown spots on the back of leaves
- Browning of leaf tips
- Burnt patches on leaves

All of these symptoms can result from disease, as well as nutrient imbalance or water deficiencies and many can be diagnosed by comparing the appearance of the trees and leaves to descriptions in standard reference books (ARDC 1969, PNW 1995, USDA 1989). However, unless the person who initially identifies the symptoms has some forestry experience, when these symptoms are observed, consultation with a forestry specialist is required to determine the best course of action.

2.4.2 Tree Nurturing and Damage Response Activities

The following tree nurturing activities are implemented during O&M activities at the North and South Plantations:

- Weed control (pulling by hand, hand tools, gas-powered trimmer)

- Localized pest removal (removal of affected branches and leaves)
- Additionally, pruning of low hanging dead branches for health and safety purposes at the direction of the Site Safety & Health Officer (SSHO), (e.g., branches in the walking area that pose a hazard to workers)

The following tree nurturing activities may be implemented during O&M activities at the North and South Plantations:

- Thinning and pruning at the direction of a forestry specialist, per the scope of work
- Irrigation at the direction of the Navy RPM for NBK Keyport and/or per the scope of work
- Fertilization at the direction of the Navy RPM for NBK Keyport and/or per the scope of work

Other nurturing activities will be implemented only if field conditions observed during regular inspections warrant corrective actions. For example, herbicides are applied only if substantial weed growth is observed and only at the direction of the Navy RPM for NBK Keyport and/or per the scope of work.

The following subsections provide recommended methodologies for nurturing activities, and actions taken in response to a recognized tree health threats.

Weed Control

Physical removal of weeds by hand pulling, hand tools, or powered gas trimmer is necessary to ensure healthy tree growth to allow effective uptake of COCs by the trees.

Based on recent observations, weeds have become less of a problem because of the closing in of tree canopies at both plantations as the poplar trees have matured. Weeds are currently controlled by removal through physical means such as regular pulling, cutting, and offsite disposal in early spring before they become well established.

If weed control measures beyond physical methods (e.g., herbicide application) are necessary, the Navy RPM for NBK Keyport must be notified. Application of herbicides should take place in spring (May), before weeds become established and must consist of application of non-persistent contact and pre-emergent herbicides applied within tree rows and along the perimeters of the plantations. A Washington-state-licensed herbicide applicator must be hired as the subcontractor for herbicide application, and the herbicide used must be approved by NBK Keyport environmental personnel before use. The herbicide selected must be designed

for use near surface water areas. The type, quantity, and application location of herbicides must be recorded in the field notes and documented in the subsequent status reports. The Navy will notify regulators and stakeholders regarding the type of herbicide to be applied, the application rate, and the duration of application.

Pest Control

Insect control may be required during LTM and maintenance of the plantations. In cases where insect pest infestations are limited, affected limbs and leaves will be pruned from the affected tree(s), bagged, and disposed of as solid waste (see Materials and Waste Management, Section 4).

When insect infestation is extensive and affects multiple trees, the Navy RPM for NBK Keyport must be notified. A forestry specialist must evaluate the need and scope of pesticide application and the application of pesticides must comply with the pesticide management plan established for NBK Keyport.

Based on recent monitoring and tree nurturing results, localized pest problems are expected to exist in the future at both plantations. The following are observed pest problems that are expected to recur and associated corrective actions:

- **Tent Caterpillar:** Tent caterpillar infestations were widespread in the plantations in May and June of 2003, and occurred again in 2006. A combination of physical removal and pesticide (pyrethrin) application was used to control the caterpillars. Systemic-pesticide application was last conducted in March 2010, and there have been no significant infestations since that time. Should tent caterpillars reemerge at infestation populations similar to 2003, pesticide application may be required. The Navy RPM must be notified and a forestry specialist must evaluate the need for, and scope of pesticide application. Generally, pesticide application for tent caterpillars should occur in early summer. Previous pesticide applications have involved one to two applications of *Bacillus thuringensis* at the two plantations. *Bacillus thuringensis* is a common and harmless bacterium that has been used for years as a biological control for a variety of larval insect stages. It is considered safe and often used in home and commercial gardens for control of various worms that infest vegetables. Application of *Bacillus thuringensis* is conducted soon after the emergence of the caterpillars and continued as needed. The base-operations contractor (BOSC) can conduct pesticide applications, as arranged by the Navy RPM and recommended by the forestry specialist.

- **Stem Borer:** The extent of the stem borer infestation at the north plantation was documented in the January 2004 Phytoremediation Inspection and Monitoring Report (TEC LTM Team 2004). Fourteen trees were found to have obvious stem borer activity. The locations of the infected trees were documented in the report, and were flagged in the field. From March/April 2004 through 2010, these infected trees were treated in early spring with a systemic pesticide such as Merit or Digone. The BOSC can apply systemic pesticides, as arranged by the Navy RPN and recommended by the forestry specialist. The project biologist must evaluate the results of pesticide applications and report these results in the subsequent Annual O&M report.
- **Aphids:** Aphids were found throughout both plantations in July and August 2003. The infestation appeared to coincide with water stress observed in most of the trees in both plantations. Although aphid infestations do not pose an immediate threat to tree health, severe aphid infestations can weaken tree health and can lead to other more threatening diseases or insect infestations. The plantations must be closely monitored for water stress during early summer to ensure that optimum tree health is maintained throughout the summer, as healthy trees are the best protection against aphid infestation. If severe aphid infestation is evident, localized pruning of damaged limbs or biological control by ladybugs will be implemented at the affected area(s). If the ladybugs are not effective at controlling the Aphid infestation, an environmentally-safe surfactant and water solution will be sprayed on the affected areas. If this does not control the Aphid problem, pesticide application is warranted, so the Navy RPM will be notified and a forestry specialist will be consulted to determine the scope of application and the type of pesticide to be used. The BOSC can conduct pesticide application, as arranged by the Navy RPM and recommended by the forestry specialist.

If pesticide application is necessary, the Navy will notify regulators and stakeholders regarding the type of pesticide to be applied, the application rate, and the duration of application.

After pesticide application, fallen limbs and leaves will be bagged, removed from the plantation and disposed of in the on-site solid waste dumpsters (see Section 4 for disposal details).

If rodent damage is suspected, weed control to eliminate ground cover that provides rodent habitat can minimize damage to the trees by rodent pests (refer to the Weed Control section, above).

Thinning and Pruning

Thinning and pruning are only included in the current scope of work if directed by the Navy RPM after consultation with a forestry specialist.

The poplar trees at both plantations are mature, and no future plantation-wide thinning is believed to be required. However, limited thinning and pruning may be required during O&M of the plantations to optimize the overall health of the plantations. Insect-infested trees, limbs damaged by wind or ice, or dead from lack of sunlight due to the enclosed canopy, will be removed. Any substantial thinning and pruning should be evaluated by a forestry specialist. Fallen branches will be removed from the plantations and placed in vegetated areas surrounding the plantation perimeters. See Materials and Waste Management in Section 4.

It should be noted that the tree tissue has been tested and demonstrated to be non-hazardous and can be recycled or disposed of at the Navy's discretion (Navy 2003). The tree tissue is acceptable for any use, including residential fireplace fuel or landscaping wood chips. Wood chips should not be spread among the trees as the breakdown of the chips depletes the soil of nitrogen.

Thinning of poplar trees requires cutting the tree down near the base of the trunk and spraying the stump with a non-persistent herbicide to prevent regrowth.

Irrigation

Irrigation using the existing irrigation system may be performed during the current scope of work at the direction of the Navy RPM for NBK Keyport; however, it is not currently scheduled.

In general, irrigation should be avoided to encourage the trees to uptake water from the shallow aquifer. It is possible, however, that an unusually hot summer could cause the trees to deplete the shallow aquifer and to begin exhibiting symptoms of water stress. In such a condition, the existing drip irrigation system can be used to apply limited quantities of water until the condition of the shallow aquifer returns to normal.

Selection of an optimal irrigation schedule should be made in consultation with a forestry specialist. Over-irrigation is undesirable because there is a small potential for very high volumes of irrigation water to leach additional contaminants from the landfill debris. Based on the irrigation schedules used successfully during the first two growing seasons, a generally acceptable irrigation schedule is in the range of 1 hour, four times per week, per irrigation zone. If only a portion of the plantations exhibit water stress, it is possible to irrigate only selected zones using the existing irrigation system.

The existing irrigation system was originally constructed to integrate some contaminated water from wells penetrating the shallow aquifer; however, this feature has been decommissioned (see Section 2.2.2). Currently the system is designed to draw water from the NBK Keyport domestic water supply system. A detailed description of the irrigation system components, as well as the programming and use of the irrigation system, is included in the phytoremediation closure report (Navy 1999a). An update to this as-built information is included in Section 2.2.2 of this plan.

In 2006, the automatic features of the irrigation system became inoperable, and the system has been manually operated since that time on an as needed basis.

If trees show signs of water stress during the summer growing season, the drip irrigation system needs to be manually reactivated. This procedure entails reconnecting the tap water supply to the system and opening several control valves. A detailed, step-by-step description of how to reactivate the irrigation system is provided in Section 2.5.2.

If the system is reactivated, piping and drip lines of the entire system should be inspected for functionality and leaks. Signs of problems include no water observed from sections of the drip line(s) and water accumulation on the soil surface near piping or connections.

Appendix A, Figures 4 and 5 are the as-built drawings of the entire drip irrigation system for the North and South Plantations. These figures illustrate the construction layout and various parts, and materials used for the system. The figures should be consulted prior to beginning any system repair.

If used, the piping should be winterized at the end of each growing season. Winterization procedures are discussed under Piping Winterization in Section 2.5.1.

Fertilizer Application

Applying fertilizer is not currently part of the scoped work. Fertilizer application will only be conducted at the direction of the Navy RPM for NBK Keyport, in collaboration with a forestry specialist.

In the past, three rounds of fertilization were scheduled during the growing season for both plantations because of the generally poor nutrient levels found in the site soil: two applications of high-nitrogen fertilizer and one application of balanced fertilizer.

Fertilization occurred in spring and early summer (before August to prevent late season growth). Dry granular fertilizers were applied to the soil by hand casting and with an applicator along tree rows, and was timed to precede rain events for “watered in” applications. Approximately 180 pounds of fertilizer was applied to each plantation during

each fertilization event. However, the fertilizer applications ceased after the 2010 growing season and were conducted again from 2015 through 2017. Further fertilizer application is not planned unless tree and/or site conditions warrant implementation.

If required, dry granular fertilizers should be added to the soil as needed by hand casting and with an applicator along tree rows, not at the base of the trees. Fertilization should be timed (to the extent practicable) such that the fertilizer is “watered in” by rainfall soon after application. Fertilization should be based on typical application rates for commercial plantations. The type, quantity, and location of fertilizer application should be determined in consultation with a forestry specialist, approved by the Navy RPM for NBK Keyport and recorded in the field notes and documented in the status reports. The soil at both plantations has been historically nutrient poor and, when warranted, a twice-yearly application of a high-nitrogen (21-0-0), slow-release fertilizer has been recommended. Application amounts in the past vary from 125 to 180 pounds per plantation.

Nutrient-targeted fertilization is applied only at the recommendation of a forestry specialist based on yearly inspections. Fertilization is not conducted after late August, as it is not desirable to encourage new growth near the onset of fall when buds are hardening for the winter.

Dead Tree Removal

Several standing dead trees are present in the North Plantation, which are currently scoped to be removed in 2018 by a professional tree removal service. Removal of dead trees may open the canopy, decrease crowding of the nearby live trees, and prevent damage to live trees when the dead trees eventually fall down.

The nine trees which have been identified to be removed are: R2T4, R3T2, R5T3, R6T7, R13T15, R14T14, R15T1, R15T4, and R17T12 (where R = row starting at the eastern edge of the plantation and moving west, and T = tree starting at the southern margin of the plantation and heading north).

Tree R17T12 was a live tree from which the entire leaf canopy broke off in February 2018, and is presumed to be dead. The trees are typically 8 inches in diameter and from 15 to 46 feet tall.

A licensed subcontractor will perform the tree removal by felling the dead trees with a chainsaw and other appropriate tools from the ground surface. No manlift is planned or anticipated to fell the trees between the live remaining trees on the plantation. The trees will be bucked up, with branches and trunk wood removed from the site.

2.4.3 Reporting and Documentation

Two types of reports will be prepared to document phytoremediation activities at OU 1. Tree Health Monitoring email reports and an Annual O&M report. See Section 6 for details.

2.5 PLANTATION FACILITIES MAINTENANCE

Because the irrigation system is no longer used, regular maintenance of the existing facilities is minimal. Regular maintenance items include the following:

- General upkeep of the interior of the service shed, emptying trash, and changing light bulbs
- Winterization of the aboveground piping in the fall and reconnection in the spring, if used

Except for general upkeep, these maintenance activities are described in the following subsections.

2.5.1 Piping Winterization

A process flow diagram identifying the remaining system components discussed in this section is provided in Figure 2-1. The reusable major components of the irrigation system are included in Table 2-1.

Prior to freezing weather each year (November), the tap water supply must be shut off at the backflow preventer and the piping drained. Both valves on the backflow preventer should be closed. The valves on the piping in each plantation should be opened, and the valves on the main plantation water supply piping should be opened. The air compressor is then attached to the quick-disconnect fitting, and compressed air should be blown through the piping for approximately 1 hour to eject water from the piping. The compressor should then be disconnected, and the valves in the plantations and the shed should be closed.

2.5.2 Reactivating Irrigation

Irrigation using tap water can be manually initiated with minimal effort, as follows:

- Leave the valves on piping within the plantations (at the north and south ends of the tree rows in the North Plantation, and at the south end of the tree rows in the South Plantation) closed.
- Open the valves on the water supply lines in the shed to each of the plantations (located along the west wall of the shed; see Figure 2-2).

- Open the two main tap water supply line valves (located along the north wall of the shed on either side of the backflow preventer; see Figure 2-3); the water flow meter should show water movement (approximately 3.5 cubic meters per minute when valves are all fully open).
- To shut the system down, reverse the process.

2.5.3 Decommissioning Irrigation System

No decommissioning activities are currently planned or scoped. Any use other than phytoremediation must comply with the Institutional Controls Plan (Navy 2017c) and must take into account the continued presence of the former landfill beneath OU 1. For any future use that allows unrestricted access to the plantations, a barrier (such as a soil cover) must be provided to prevent casual contact with landfill debris. Such a barrier must comply with Section 11.4 of the ROD (Navy, EPA, and Ecology 1998).

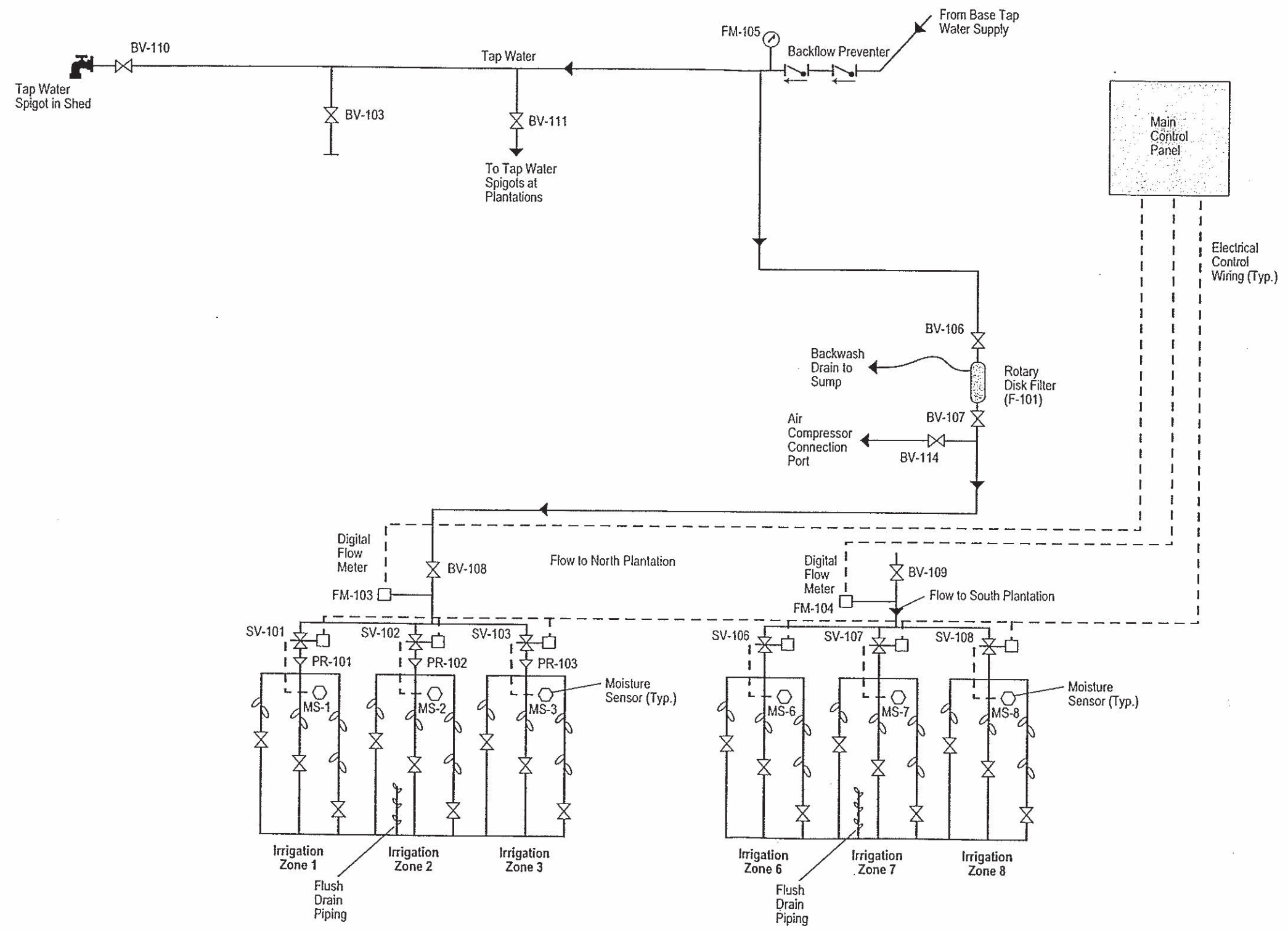

Notes:
 1. Electrical power supply wiring not shown.

Figure 2-1
 Irrigation System Process Flow Diagram
 Following Partial Decommissioning

U.S. NAVY	Delivery Order 0021 NUWC Division Keyport Keyport, WA
	PHYTOREMEDIATION O&M PLAN

Table 2-1. Reusable Major Components of Irrigation System

Label	Function	Refurbish? ^{1/}	Decontamination? ^{2/}	Other Comments
Air compressor	Blow water from components for winterization	No	No	Excellent condition, low usage.
FM-105	Record total tap water flow	No	No	
FM-103, FM-104	Digital flow meters for recording total water flow and flow rate to plantations	No	No	Decontamination unnecessary because thousands of gallons of tap water have passed through since the use of contaminated water was discontinued. Only flow sensors are installed in piping; reuse requires other electrical components integral to the main control panel (equivalent required components can be purchased separately).
Backflow preventer	Protect base water supply from contamination	No	No	
Sump pump	Keep floor of shed dry	No	Yes	Pump-wash water through pump
F-101	Filter particulates from irrigation water	No	No	Decontamination unnecessary because thousands of gallons of tap water have passed through since the use of contaminated water was discontinued.

Notes:

^{1/} Entries in this column indicate whether the component is likely to require refurbishment by either onsite personnel or the manufacturer prior to reuse.

^{2/} Entries in this column indicate whether the component should be decontaminated by a Citronox wash and tap water rinse prior to reuse.

Some components not listed (e.g., individual ball valves) may be reusable in some applications. The main control panel may be reusable for a specific application; the manufacturer should be contacted when an application is identified.

Figure 2-2. Layout of North Plantation Shed Irrigation System – West Wall

2-26

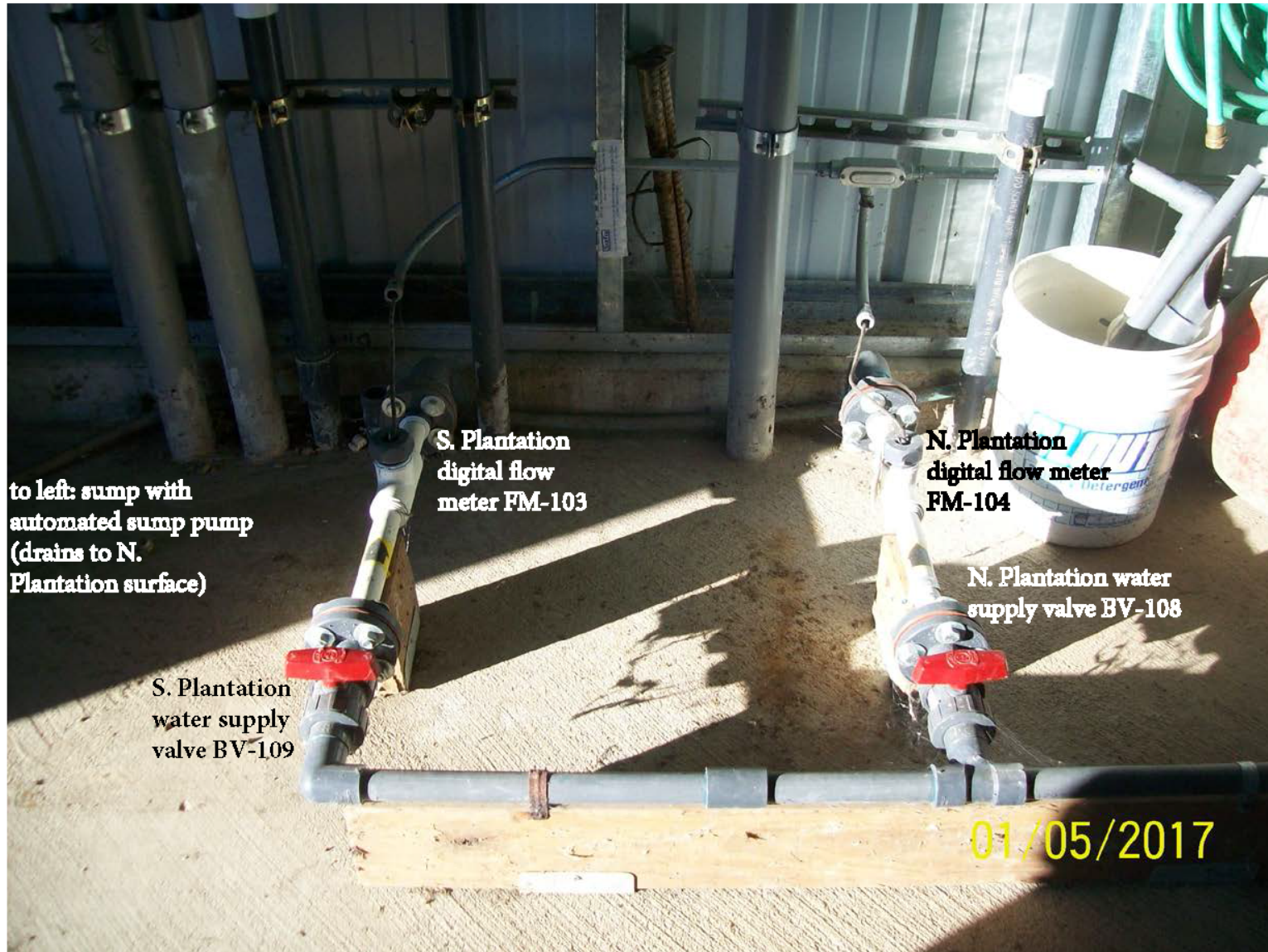
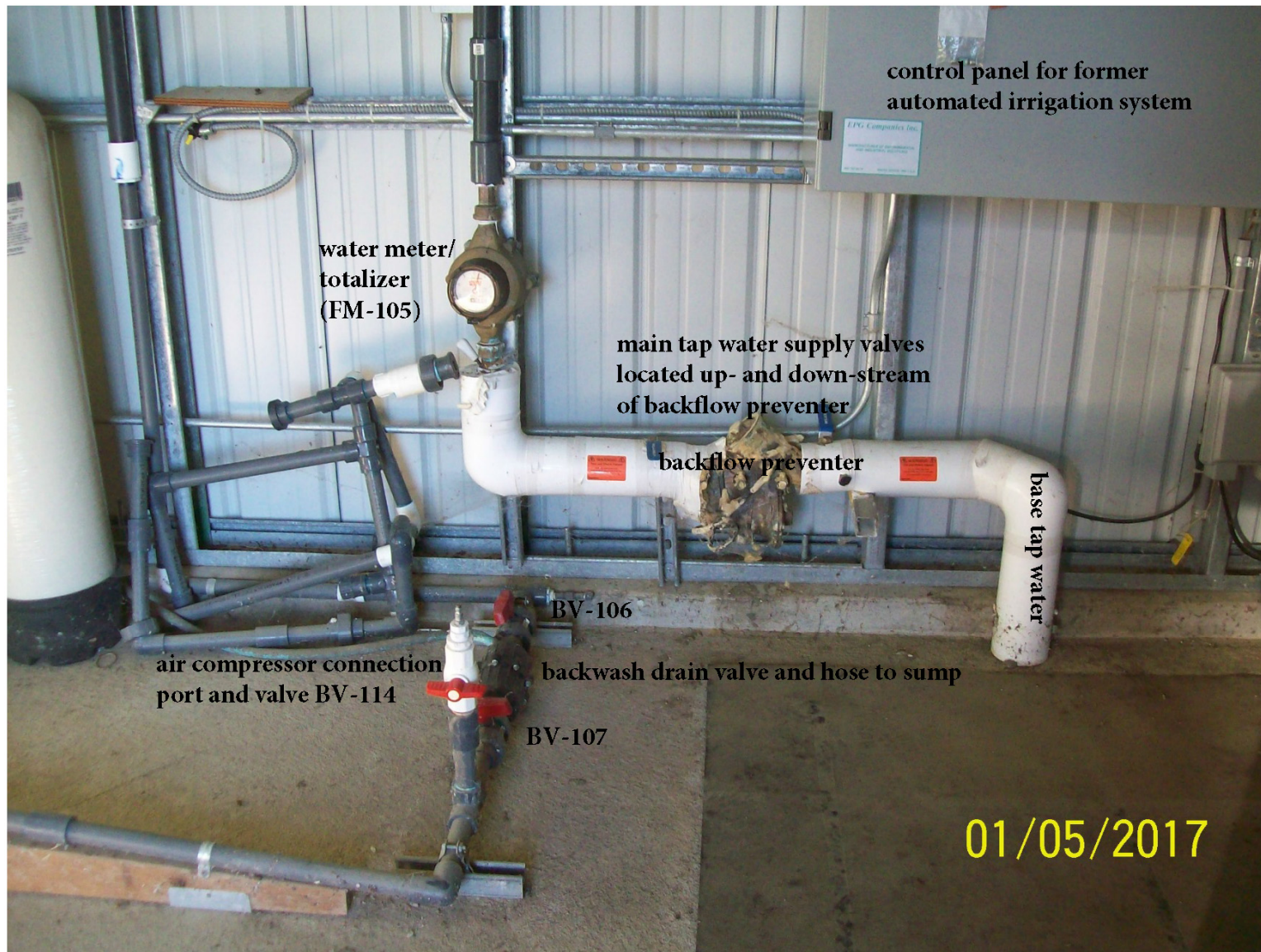

Figure 2-3. Layout of North Plantation Shed Irrigation System Piping – North Wall



2-27

2.6 TIDE GATE INSPECTION AND MAINTENANCE

This section describes the sediment removal and tide gate replacement project, tide gate operating principles, inspection requirements, maintenance activities, waste disposal, and repair activities. A manufacturer's O&M manual and drawings are included in Appendix D, and the tide gate inspection form is included in Appendix B.

2.6.1 Sediment Removal and Tide Gate Replacement

The polychlorinated biphenyl (PCB) concentrations in the marsh outlet-channel sediment were below the levels established by state regulations that would require the sediments to be actively remediated. However, the Navy decided to remove the upper layer of sediments downgradient of the landfill seep to reduce the potential for PCB concentrations to exceed the cleanup level in the future, and to reduce the likelihood of PCBs entering the Tide Flats. The sediment removal was conducted in late summer 1999. Characterization sampling was conducted first for waste profiling. As specified in the ROD, 6 inches of sediment were removed from the delineated removal area using a high-pressure vacuum truck, making sure to protect existing root systems. The sediment was vacuumed and direct-loaded into sludge boxes for disposal. Overall, roughly 75 tons of sediments were disposed of at an approved landfill.

The upgrade of the tide gate and culvert was intended to provide greater control of tidal fluctuation in the marsh and to protect the landfill from extreme tidal events that might flood the landfill and erode the embankment at the toe of the landfill, thus potentially disturbing the buried landfill contents. A concrete culvert was installed and the tide gate upgraded in November 1999.

The phytoremediation closure report describes the sediment removal and tide gate upgrade activities (Navy 1999a).

2.6.2 Tide Gate Operating Principles

The tide gate installed by the remedial action contractor is a self-regulating tide gate manufactured by Waterman Industries, Inc. Operation of the tide gate is controlled solely by the tidal cycle and tide levels; no external power or manual operation is required. The tide gate uses the "moment of force" principle, whereby the gate relies on float buoyancy and float position to achieve the weights and balances required to close and open the gate at the desired water level within its normal range of operation. The contractor made the initial adjustment on the float position based on the tidal levels at the site, and documented that the tide gate was working properly in 1999 (Navy 1999a). There have been no reports of tide

gate malfunctions since commissioning. One of the two floats on the tide gate was damaged and replaced in 2015. However, the tide gate is designed to operate using only one of the two floats, so operation of the tide gate was not impeded.

Appendix D includes the O&M manual from the manufacturer, and will serve as the basis for tide gate inspection and maintenance work. Additionally, Appendix D includes the shop drawings of the Keyport tide gate showing the configuration and major components, and comments on the shop drawings from the remedial action contractor regarding the installation details and tide elevations. The following subsections describe specific inspection and maintenance requirements based on the manufacturer's recommendations, as well as field observations and findings made during the first two years (2002 through 2003) of inspection and maintenance activities.

2.6.3 Inspection Requirements

The objective of the inspection and maintenance program is to conduct periodic checks on the tide gate to ensure it is functioning properly. The physical conditions of the critical components and parts will be inspected, and the functionality observed during a tidal cycle (checking for the opening and closing as well as the back float operation in response to rising and receding tides).

The following items will be inspected during each inspection event:

- Check for visible physical damage of the tide gate, concrete collar, and 36-inch concrete culvert.
- Check the physical condition of the back floats.
- Inspect the condition of the vacuum break.
- Check the physical condition of the moving parts, including the vertical floats located in the tide gate frame.
- Inspect the condition of the paint.
- Look for visible debris lodged or accumulated on the tide gate or inside the concrete culvert.
- Check the security gate at the upstream end of the culvert to make sure it is present and in good condition.
- Inspect the plastic isolation sleeves and washers at contact points between the aluminum gate flange and stainless steel anchor bolts (for corrosion protection).

The inspection will be documented on the Inspection and Maintenance Form presented in Appendix B.

Operation of the tide gate will be observed through an entire tidal cycle (high to low) to verify that the gate opens and closes at the intended water levels, and to verify the free rotation of the back floats and lateral doors. Based on the schematic drawings in Appendix D, construction notes, and field observations made during the first-year tide gate maintenance activities, the gate should begin to close when the incoming tide reaches 3 feet above the tide gate invert (bottom) elevation. This tidewater elevation will be verified during the inspection. The gate should remain closed whenever the tidal water elevation is above 3 feet (high water elevation is expected to be approximately 2.5 to 4 feet above invert), and the gate is expected to stay open (in various opening positions) when the tidal water elevation is below 1.86 feet. The tide gate should start oscillating toward closure when the water level approaches approximately 3 feet above the invert. A high tide of approximately 10.2 feet msl or higher is required for the tide gate to fully close.

During the tidal cycle observation, the water level (above invert) at both ends of the culvert will be measured and documented every 30 minutes, from 2 hours before the high tide to 2 hours after, or for extremely high tidal events, measurements should be made from approximately 2 hours before predicted tide gate closure to 2 hours after. The measurements will be used to document that the tidewater level upstream of the tide gate is effectively controlled by closure of the tide gate and to check that significant leakage (that could cause flooding of the marsh channel above the tide gate) is not occurring. Water level elevations at the tide gate (tide flats side) and at the upper culvert security gate (marsh side) will be measured using survey rods/gauges. Measurements will be documented on the field inspection and maintenance form (Appendix B), and in the field logbook.

2.6.4 Maintenance Requirements

According to the manufacturer's O&M manual (Appendix D), minimal routine maintenance is expected for the tide gate, as operation of the tide gate is self-regulated by tidal water and no powered mechanism is used for the tide gate operation. The manufacturer claims that the tide gate is designed to last indefinitely if properly maintained and major repairs are not expected. The primary maintenance activity will be to remove accumulated debris that may hinder the operation of the tide gate. Access to the tide gate from the tide flats requires a low tide of approximately 2-3 feet or less above msl. The following are the expected maintenance activities for the tide gate that may be required during each inspection event:

- Remove any biofouling (e.g., seaweed, barnacles, and mussels), sediment, or debris (sticks and leaves) lodged in or accumulated on any parts of the tide gate that may obstruct or interfere with the operation of the tide gate.
- Check and clean (if necessary) the vacuum-break vent to make sure it is free of obstruction.
- Remove any biofouling or debris from the culvert that may obstruct the designed conveyance of water through the culvert.
- If needed, recalibrate the vertical floats to approximately 18 inches above the water surface, as recommended by the tide gate manufacturer, to minimize oscillation of the gate lid before it is closed by the incoming tide.

Debris will be removed by hand scraping or power washer only. Mechanical cleaning equipment with hard or abrasive surfaces is not recommended as it may damage the surfacing or small parts of the tide gate.

Other float adjustments, in addition to the calibration described above, may be needed to optimize the tide gate performance. If this becomes necessary, the manufacturer's tide gate O&M manual (Appendix D) will be consulted, and the manufacturer will be contacted for technical direction before minor adjustments are made.

Most inspection and maintenance work will be accomplished during low tide (approximately 2-3 feet or less above msl) for accessibility and safety, and over-water operations (using a boat) will not be required.

2.6.5 Tide Gate Maintenance and Monitoring Schedule

Because of the rapid accumulation of barnacles and mussels, cleaning and maintenance activities will be conducted on a quarterly basis, scheduled during low tides in February, May, August, and November (refer to Section 5). Monitoring the tide gate closure and opening will occur on the same schedule if feasible; tidal conditions may require separate days for monitoring, inspection, and cleaning based on appropriate tides.

In the event that the predicted tide is not sufficiently low enough to perform maintenance and monitoring of the opening or closing of the tide gate, semi-monthly visits to the site to visually confirm that the tide gate is open during a low tide and closed at high tide will occur until the measured monitoring event can be completed.

2.6.6 Additional Information on Repair Activities

No major repair activities are planned for the tide gate O&M work. If replacement parts are needed to make minor repairs (e.g., replace the floats), the parts will be ordered through the manufacturer (Waterman Industries) or through another suitable supplier/manufacturer. Part numbers and specifications are found in the schematic drawings in Appendix D.

If major repairs (e.g., replacement of a gate or repair of concrete structures) or major readjustment of the back floats are required, the Navy will be contacted immediately following the inspection to arrange for repairs. This work plan does not address major repair.

The manufacturer's contact information, for major technical and repair issues, is as follows:

Waterman Industries Inc.
P.O. Box 458
Exeter, CA 93221
Phone: 559-562-4000
Fax: 559-562-2277

The manufacturer's Job Number for the Keyport tide gate is L-4551. This number must be referenced if the manufacturer is contacted for technical and/or repair information.

2.7 OUI AREA 1 WELL RESURVEY

A well survey will be conducted in support of LTM activities at OU 1 for Area 1 monitoring wells which existed prior to 2016 (Figure 2-4).

2.7.1 Mobilization

A CHMI will be submitted to the Navy for any hazardous materials that are to be brought on site, including those in subcontractor's vehicles. Details on the CHMI process are discussed in Section 4 Materials and Waste Management.

2.7.2 Well Resurvey

A survey to update the top of casing measurement will be performed for the 27 wells listed in Table 2-2. The survey will be conducted by a licensed surveyor, True North Land Surveying, Inc. The new top of casing measurements will be reported using the NAVD 88 datum.

Table 2-2. Monitoring Wells to be Surveyed

Well Name	Well Type	Well Casing Diameter (Inches)	Northing (feet) ^{1/}	Easting (feet) ^{1/}	Previous Top of Casing Elevation (feet above msl)
1MW-1	MW	2	1198801	259561	10.04
1MW-4	MW	2	1199022	260033	
MW1-02	MW	2	1198862	259765	11.85
MW1-03	MW	2	1199228	259637	13.53
MW1-04	MW	2	1199055 ^{2/}	258973 ^{2/}	12.23
MW1-05	MW	2	1198866	259079	13.08
MW1-06	MW	2	1198856	259229	13.21
MW1-09	MW	2	1198538	259488	12.01
MW1-10	MW	2	1198537	259477	
MW1-11	MW	2	1199229	259633	
MW1-14	MW	2	1198993	259765	
MW1-15	MW	2	1198968	259502	13.30
MW1-16	MW	2	1199012	259065	12.83
MW1-17	MW	2	1198799	259441	9.55
MW1-18	MW	2	1198982	259978	
MW1-19	MW	2	1199072	260097	
MW1-20	MW	2	1199233	259001	10.42
MW1-23	MW	2	1198983	260385	
MW1-24	MW	2	1199161	260201	
MW1-25	MW	2	1198791	259832	11.91
MW1-27	MW	2	1199224	259633	
MW1-28	MW	2	1198712	259725	13.10
MW1-29	MW	2	1198634	259618	
MW1-31	MW	2	1199258	259373	
MW1-38	MW	2	1198474	260203	9.83
MW1-39	MW	2	1198478	260208	9.85
MW1-41	MW	2	1199000	259673	

Notes:

^{1/} Horizontal survey based on Washington State Plane Coordinate System, North Zone (NAD 83) source: Naval Installation Restoration Information Solution (NIRIS).

^{2/} Well coordinates obtained from historical figure.

MW – Monitoring well

bgs – below ground surface

msl – mean sea level

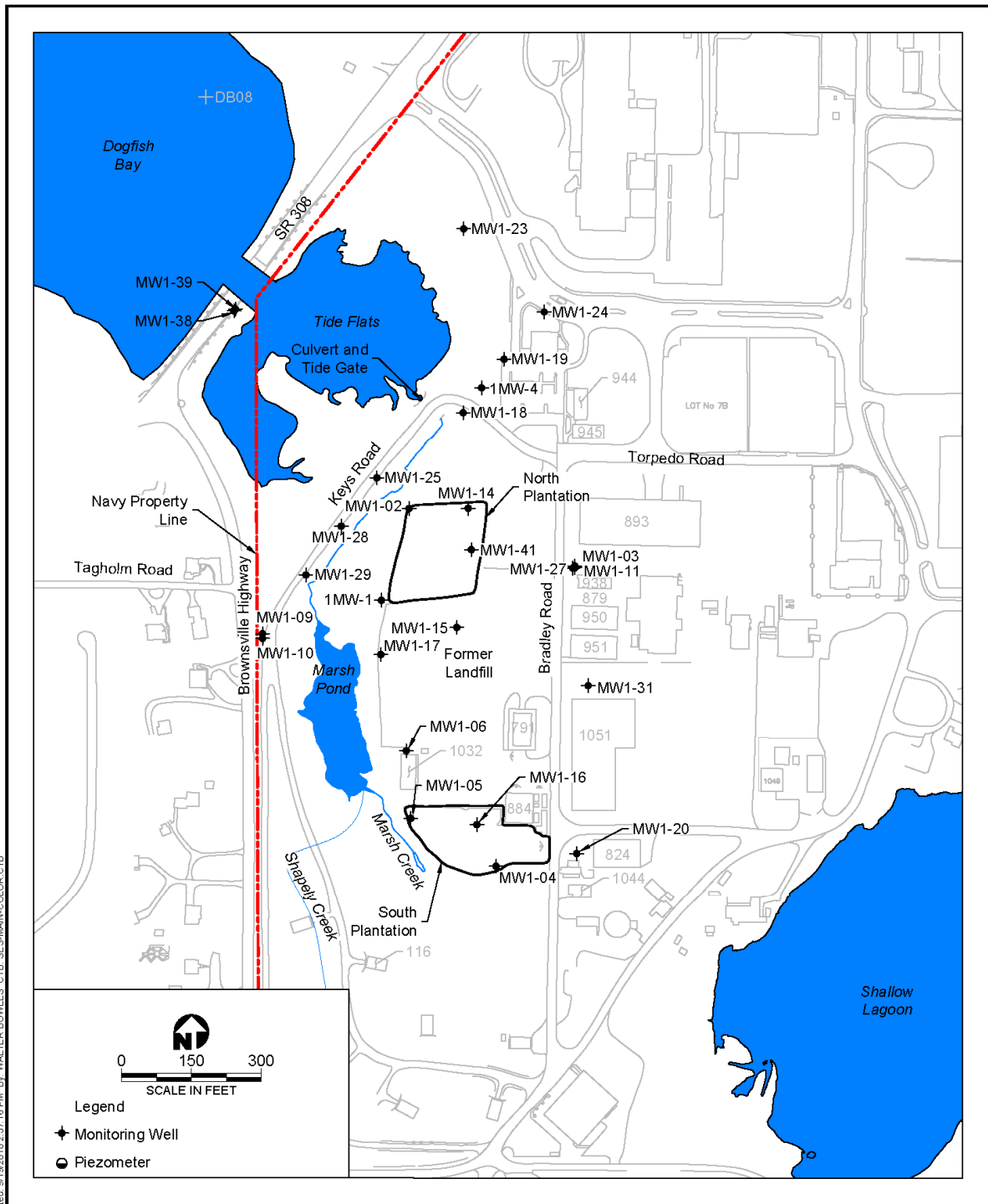

C:\USERS\WALTER.BOWLES\DOCUMENTS\KEYPORT\18F4214\08\NATIVE\FIG 2-4.DWG
 Mod: 9/19/2018 2:56:34 PM. Plotted: 9/19/2018 2:57:16 PM. By: WALTER.BOWLES. CTE. SES-MAN-COLOR.CTB

<p>U.S. NAVY SEALASKA</p>	<p>SEALASKA</p>	<p>Figure 2-4 Monitoring Wells to be Surveyed OU 1, Area 1</p>	<p>NBK Keyport O&M Plan Update</p>
----------------------------------	------------------------	--	---

3. OPERABLE UNIT 2 AREA 8

3.1 SITE DESCRIPTION AND HISTORY

Area 8 occupies approximately 1 acre on a manmade peninsula in the eastern portion of NBK Keyport, surrounding the location of a former plating shop. The site is located in a heavily industrialized part of the base bordered by Port Orchard Bay to the south and east (refer to Figure 1-1). The area is predominantly flat and almost entirely paved or covered by buildings.

Past releases at Area 8 include chrome-plating solution spilling onto the ground, plating wastes discharging to a utility trench, and plating solutions leaking through cracks in the plating shop floor, waste disposal pipes, and sumps. Petroleum hydrocarbons (diesel and heavy oil) were also released to the environment from leaky underground storage tanks (USTs) and underground concrete vaults located within Area 8.

Extensive subsurface soil and groundwater sampling was conducted to determine the contaminants of concern (COCs) and their extent, as summarized in the MMA SAP (Navy 2018c). The RI/FS process, and initial human health and ecological risk assessments for OU 2, Area 8 were completed in 1993. No human health or ecological risk was identified in association with OU 2, Area 8. However, remedies were selected based on (1) unacceptable risks from exposure to soil and groundwater to future hypothetical residential areas, and (2) the potential for human health and ecological exposures from contaminants discharging to Port Orchard Bay and impacting marine sediment and tissue. The ROD, prepared and approved in 1994, outlined the selected remedies for the site including continued groundwater monitoring, sediment and tissue monitoring, and ICs to restrict residential use of the site, and remove hot spots of vadose-zone soil for offsite disposal.

Additional remedial actions at Area 8 since 1995 include the demolition of the plating shop, the removal and disposal of hot spot (metals-contaminated) soil, and the removal of USTs and associated petroleum-contaminated soils. Two slurry walls were constructed at the location of former USTs to provide shoring during petroleum-contaminated soils removal. These slurry walls remain in place and are not tied to an aquitard, so they retard, but do not prevent groundwater flow.

Current LTM activities at this site include sampling of groundwater from monitoring wells and from one seep for comparison to established criteria.

The depth to water in the aquifer is generally less than 10 feet below ground surface (bgs). Although intermittent reversals from tidal influence have been inferred in wells near the shoreline during high tide, horizontal groundwater flow is generally eastward toward the shoreline.

3.2 OU 2 AREA 8 WELL REDEVELOPMENT

Three existing wells will be redeveloped from OU 2 Area 8; monitoring wells MW8-8, MW8-11, and MW8-12 (Figure 3-1, and Table 3-1).

3.2.1 Well Selection for Redevelopment

The initial reported total depths for three wells MW8-8 (19.5 feet), MW8-11 (17.5 feet), and MW8-12 (17.5 feet) are all significantly greater than recent 2017 measurements (18.30 feet, 15.96 feet, and 14.13 feet, respectively; Navy 2018b). These wells likely have silted in over the years.

Monitoring wells MW8-8, MW8-11, and MW8-12 will be redeveloped by surge and purge methods, following applicable NAFVAC Northwest standard operating procedures (SOPs), to remove sediment from the bottom of the wells and ensure connection with the surrounding formation and aquifer.

Well redevelopment activities are described below, and waste management for this task is described in Section 4.

3.2.2 Mobilization

Prior to onsite mobilization, an area outage request will be submitted to the Navy RPM for Keyport approval to ensure access is available around each well. It is assumed that at least three parking spaces around each well will be needed for the work zone to stage the well development truck, equipment, supplies, and personnel. The work zones will be blocked off with traffic cones or similar the night before work commences.

A CHMI will be submitted to the Navy for any hazardous materials that are to be brought on site, including those in subcontractor's vehicles. Details on the CHMI process are discussed in Section 4 Materials and Waste Management.

Keyport Environmental will be contacted (through the NAVFAC Northwest RPM or Navy Technical Representative [NTR]) to arrange for drop off of three 55-gallon drums for waste management prior to subcontractor arrival onsite.

3.2.3 Well Redevelopment

A subcontracted Washington State licensed driller (Cascade Drilling) will perform the well redevelopment. Redevelopment will be performed in accordance with field procedures from the MMA SAP (Navy 2018c): A.1 Water Level Measurement, A.10 Site Logbook, A.11 Decontamination of Field Instrumentation, and A.12 Water Quality Meter Calibration included in Appendix A of the MMA SAP (Navy 2018c), and the Well Development Field Procedure included in this O&M Plan, Appendix B. The well development field procedure is based on NAVFAC Northwest SOP I-C-2. Prior to commencing the redevelopment activities, the well will be opened and the depth to water and the depth to bottom will be measured. Redevelopment activities will be performed for up to two hours per well, and activities will not exceed one 55-gallon drum of development water (includes sediment, groundwater, decontamination water and purge water).

Each well will be mechanically scrubbed and surged with alternating use of wire brush and surge block, or both in tandem, to loosen fouling and encrustation with both brush and surge block sized to the casing. Brushing and surging will be performed throughout the water column of the well, with particular effort concentrated in the screened interval to remove silt and restore the specific capacity.

The well will be pumped using a peristaltic or submersible pump to remove sediment. Ideally, the maximum purge rate should be equal to the recharge rate without drawing down the water level below the top of the screen. Field personnel will monitor water quality parameters to confirm development and record the information on the Well Development Field Form (Appendix B).

Information to be logged will include the date, well name, total volume removed, static water level before development, total depth of the well observed (before and after redevelopment), volume of water in the well prior to and after development, the surge/development method, the pumping method, the flow rate and estimated volume removed, periodic measurements of depth to water, color/clarity/odor, and the following six field parameters: pH, temperature, dissolved oxygen, oxidation reduction potential, specific conductivity, and turbidity.

Well redevelopment will continue until a minimum of three well volumes have been removed, three consecutive readings are attained for pH and specific conductivity within 10% of each other and turbidity is below 10 Nephelometric Turbidity Units [NTU]). Field crews will collect measurements either periodically (i.e., every 5 to 10 minutes) or based on volume removed (i.e., every 3 gallons or at least every well volume).

If two hours pass and the field parameter and well volume criteria have not been met, and one 55-gallon drum of development water has been collected (leaving room for decontamination water and purge water), well redevelopment activities will cease.

The redeveloped wells will have a minimum of 48 hours after the completion of the redevelopment before water level recharge is verified and sampling activities can commence.

Waste management for this activity is described under Section 4 Materials and Waste Management.

Table 3-1. Area 8 Monitoring Well Details

Well Name	Well Type	Well Casing Diameter (Inches)	Initial Well Depth ^{1/} (feet btoc)	Recent Well Depth ^{2/} (feet btoc)	Screened Interval (feet btoc)	Recent Water Level (feet btoc)
Area 8						
MW8-8	Monitoring Well	2	19.5	18.30	4.5-19.5	9.77
MW8-11	Monitoring Well	2	17.5	15.96	7-17	10.03
MW8-12	Monitoring Well	2	17.5	14.13	7-17	9.33

Notes:

^{1/} Well depth as reported in the Naval Installation Restoration Information System.

^{2/} Recent well depths and water levels from 2017 field measurements (Navy 2018b).

btoc –below top of casing

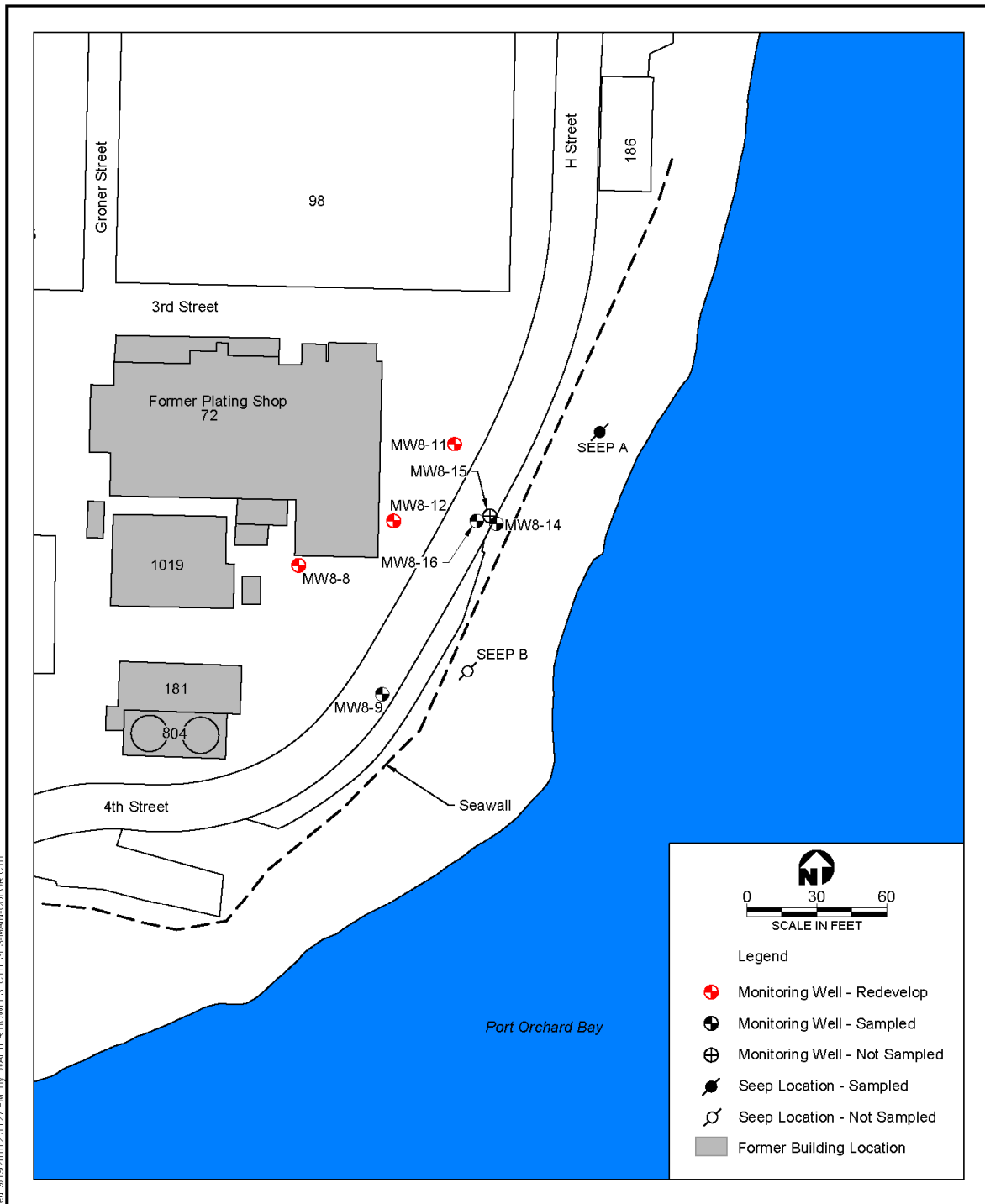

C:\USERS\WALTER.BOWLES\DOCUMENTS\KEY\FORT18F4214\O&M\NATIVE\FIG 3-1.DWG
 Mod: 9/19/2018 2:58:14 PM. Plotted: 9/19/2018 2:58:27 PM. By: WALTER.BOWLES. CTB. SES-MAIN-COLOR.CTB

<p>U.S. NAVY SEALASKA</p>	<p align="center">Figure 3-1 Location of Monitoring Wells to be Redeveloped OU 2, Area 8</p>	<p align="center">NBK Keyport O&M Plan Update</p>
----------------------------------	--	--

4. MATERIALS AND WASTE MANAGEMENT

Materials and waste management are discussed in the following sections.

4.1 MATERIALS MANAGEMENT

Gasoline that is used for powered equipment, such as landscaping line-trimmers, will be stored in work vehicles during maintenance activities in 5-gallon (or less) cans and will not be stored overnight onsite.

Prior to commencement of field activities, subcontractors performing tree removal, surveying, and well redevelopment tasks will submit a list of hazardous materials that will be brought onsite within their vehicles, even if not specific to the work being performed.

A CHMI will be submitted for review and acceptance by Keyport Environmental.

4.2 WASTE MANAGEMENT

Wastes generated from the phytoremediation and the tide gate O&M activities may include:

- Personal protective equipment (PPE)
- Leaves, branches, larger tree limbs
- Thinned out trees, includes tree trunks (not currently scoped)
- Weeds
- Empty fertilizer or herbicide containers (application not currently scoped)
- Barnacles, other biota from tide gate cleaning
- Broken tide gate parts
- Empty epoxy paint container and used rags (application not currently scoped)
- Well redevelopment water (includes groundwater, decontamination water, sediment, and purge water)

Disposable PPE, not including leather gloves, will be disposed of in the NBK Keyport dumpster at Building 824 as solid waste.

Woody waste generated by plantation-maintenance activities (such as dead branches) are moved outside the plantation perimeter fencing. Previous sampling and analyses indicated that tree tissue is not contaminated (Navy 2003).

Weeds are gathered, bagged, and disposed of in the onsite NBK Keyport dumpster at Building 824 as solid waste.

Barnacles, mussels, and other biota scraped off the tide gate and out of the culvert during maintenance activities, are left on the sediment in the bay next to the tide gate.

Any parts (such as floats) that are broken off of the tide gate and can be found are assessed first for reuse, or disposed of in the onsite NBK Keyport dumpster at Building 824 as solid waste.

The current scope of work does not include fertilizer or herbicide application, or applying paint to the tide gate. If these activities are added to the O&M program, field-change requests will be needed for waste management procedures in this O&M Plan and for activity hazard assessments in the Accident Prevention Plan/Site Safety and Health Plan.

Well redevelopment activities will generate PPE and up to one 55-gallon drum of redevelopment water per well. Well redevelopment water includes:

- Groundwater
- Decontamination water (for any pump and surge block or other downhole equipment used, and contains potable water and soap, such as liquinox)
- Sediment particulate from the ground formation
- Purge water collected for water quality parameters during development

Each drum will only be filled to two-thirds full to meet the weight restriction for each DOT certified drum. Drums will be temporarily stored at the well locations until picked up for disposal by Keyport Environmental. Keyport Environmental will provide disposal for the waste generated during well redevelopment, and will provide documentation to the Navy RPM.

5. PROJECT SCHEDULE

The current project schedule for activities is shown in Table 5-1 by month. The schedule reflects the recommendations from the Annual OU 1 O&M Report (Navy 2018a).

Table 5-1. Estimated Inspection and Maintenance Schedule for Phytoremediation and Tide Gate O&M

Activity	Estimated Month											
	Jan.	Feb.	Mar.	April	May	June	July	Aug.	Sept.	Oct.	Nov.	Dec.
Phytoremediation												
Inspections ^{1/}		S	S		S	S	S	S	S		S	
Fertilizer application ^{2/}					O	O						
Insect pest control (manual) ^{3/}		S			S	S	S	S	S			
Insect pest control (application) ^{2/4/}			O	O	O							
Weeding ^{5/}		S	S		S	S	S	S	S		S	
Thinning and pruning (living/ whole tree) ^{6/}												
Pruning (dead branches/living suckers) ^{7/}			S		S	S	S	S	S		S	
Irrigation ^{8/}						NP	NP	NP	NP			
Winterization (potable water and/or irrigation facilities) ^{9/}											S	
Spring reconnection (potable water/irrigation facilities) ^{10/}					S							
Tide Gate												
Inspections and Maintenance		S			S			S			S ^{11/}	

Notes:

- ^{1/} Includes observations of tree health
- ^{2/} Not currently included in the project scope of work; performed as needed based on inspection results with appropriate months to perform actions marked with an “O”
- ^{3/} Manual removal included in the scope of work, performed on an as-needed basis
- ^{4/} Under the direction of a forestry specialist, application of insect pest control product with possible stem borer and tent caterpillar control conducted between March and May. Systemic pesticide was last applied in March 2010 by Peninsula Services.
- ^{5/} Weeding conducted on an as-needed basis.
- ^{6/} Thinning the plantation and/or removing large living branches are included in the current scope of work, however these activities are not currently planned and would only be performed after consultation with a forestry expert. It is included here for future planning purposes only.
- ^{7/} Pruning of low hanging dead branches and live suckers; performed as needed.
- ^{8/} Irrigation is not currently planned. However, it is included in the current scope of work. Irrigation is performed based on inspection results with appropriate months to perform actions marked with “NP”.
- ^{9/} Winterization tasks are performed if the irrigation system was activated. Winterization of the irrigation system performed per Section 2.5.1.
- ^{10/} Spring irrigation system setup for system use after winterization, per Section 2.5.2.
- ^{11/} In the event that the predicted low tide is not sufficiently low to safely perform the tide gate cleaning, monthly visits to visually confirm the tide gate is open at low tide and closed at high tide will occur until tide gate maintenance can be performed.

S – Selected month to perform currently scoped work activity

O – Appropriate month to perform work, however activity is not currently scoped

NP – Appropriate month for scoped work activity that is not currently planned; only conducted if directed by Navy

6. DOCUMENTATION AND REPORTING

Separate email letter reports, one each for tree health monitoring (total of eight), and one each for tide gate O&M (total of four) will be prepared and sent to the NBK Keyport Navy RPM within 30 days following each inspection and maintenance event. Each letter report will document the inspection and findings of each monitoring and inspection event, provide any revised guidelines for scheduling future inspection and maintenance events, and will include the site inspection forms.

The results of long-term O&M for phytoremediation and the tide gate at OU 1 will also be documented in an annual O&M report, which shall include the following:

- Summary of the scope of work performed
- Methods used to perform the scope of work
- Summary of observations of tree health and actions taken to enhance tree health and growth, including types and quantities of fertilizer, weed control, irrigation water, and pesticides used, if applicable
- Record of any loss of individual trees from the plantation and the suspected reasons for the loss
- Interpretations and recommendations regarding plantation health
- Recommendations for future maintenance and/or repairs of the tide gate

The effect of the plantation phytoremediation on the reduction of contaminants, LTM methods, and evaluation of data against remedial objectives and remedial goals are presented in the Area 1 LTM Report and are summarized in the annual O&M report.

7. HEALTH AND SAFETY

Contractors implementing this O&M plan must maintain a site-specific health and safety plan that complies with 29 CFR 1910.120 and U.S. Army Corps of Engineers EM 385-1-1. Information regarding physical and chemical hazards present at the site is available in the Accident Prevention Plan/Site Safety and Health Plan for this project.

8. REFERENCES

- Agricultural Research and Development Center (ARDC). 1969. Deficiency Symptoms of Some Forest Trees. Bulletin 1015.
- United States Navy (Navy). 1999a. Phytoremediation Closure Report for Operable Unit 1, Naval Undersea Warfare Center Division Keyport, Washington. Prepared by URS Greiner, Inc., Science Applications International Corp., and Shannon & Wilson, Inc. for Engineering Field Activity, Northwest, under CLEAN Contract No. N62474-89-D-9295. December 29, 1999.
- Navy. 1999b. Phytoremediation Site Work Plan for Operable Unit 1, Naval Undersea Warfare Center Division Keyport, Washington. Prepared by URS Greiner, Inc., for Engineering Field Activity, Northwest, under CLEAN Contract No. N62474-89-D-9295. March 1, 1999.
- Navy. 2002. Phytoremediation Status Report, October–December 2001, Operable Unit 1, Naval Undersea Warfare Center Division Keyport, Washington. Prepared by URS Group, Inc., for Engineering Field Activity, Northwest, under IDIQ Contract No. N44255-00-D-2476. April 22, 2002.
- Navy. 2003. Revised Operation and Maintenance Plan for Phytoremediation at Operable Unit 1, Naval Undersea Warfare Center Division Keyport, Washington (Revision 2). Prepared by URS Group, Inc., for Engineering Field Activity, Northwest, under IDIQ Contract No. N44255-00-D-2476. CTO 0012. April 8, 2003.
- Navy. 2010. Final Third Five-Year Review, Naval Base Kitsap Keyport, Keyport, Washington. December 8, 2010.
- Navy. 2012. Final Contingent Remedial Action Plan for Operable Unit 1, Naval Base Kitsap Keyport, Keyport, Washington. Prepared by Sealaska for NAVFAC Northwest under contract N44255-09-D-4005, Task Order 44. February 29, 2012.
- Navy. 2015. Final Fourth Five-Year Review, Naval Base Kitsap Keyport, Operational Units 1 and 2, Keyport, Washington. November 20, 2015.
- Navy. 2016. Final 2015 Annual Operation and Maintenance Report, Operable Unit 1, Naval Base Kitsap Keyport, Keyport, Washington. Prepared by Sealaska for NAVFAC Northwest under contract N44255-14-D-9011, Task Order 13. August 12, 2016.

- Navy. 2017a. Final 2016 Annual Operation and Maintenance Report, Unit 1, Naval Base Kitsap Keyport, Keyport, Washington. Prepared by Sealaska for NAVFAC Northwest under contract N44255-14-D-9011, Task Order 27. August 2017.
- Navy. 2017b. Final Spring 2016 LTM Report, Operable Unit 1, Naval Base Kitsap, Keyport, Washington. Prepared by Sealaska for NAVFAC Northwest under contract N44255-14-D-9011 Task Order 27. August 2017.
- Navy. 2017c. Final Revision 3 Institutional Controls Plan, Operable Unit 1, Operable Unit 2, and Site 23, Naval Base Kitsap Keyport, Keyport, Washington. Prepared by NAVFAC Northwest. May 1, 2017.
- Navy. 2018a. Final 2017 Annual Operation and Maintenance Report, Unit 1, Naval Base Kitsap Keyport, Keyport, Washington. Prepared by Sealaska for NAVFAC Northwest under contract N44255-14-D-9011, Task Order 46. September 18, 2018.
- Navy. 2018b. Final Spring 2017 LTM Report, Operable Unit 1, Naval Base Kitsap, Keyport, Washington. Prepared by Sealaska for NAVFAC Northwest under contract N44255-14-D-9011 Task Order 46. September 18, 2018.
- Navy. 2018c. Management and Monitoring Approach Sampling and Analysis Plan; Area 1 Former Landfill, AREA 2 Van Meter Road Spill/Drum Storage Site, and Area 8 Plating Shop Waste/Oil Spill Area Long-Term Monitoring Operable Units 1 and 2, Naval Base Kitsap, Keyport, Washington. Prepared by Sealaska for NAVFAC Northwest under contract N44255-14-D-9011 Task Order N4425518F4214. In preparation.
- Navy, EPA, and Ecology (U.S. Navy, U.S. Environmental Protection Agency, and Washington State Department of Ecology). 1998. Final Record of Decision for Operable Unit 1, Naval Undersea Warfare Center Division Keyport, Washington. Prepared by URS Greiner, Inc., for Engineering Field Activity, Northwest, under CLEAN Contract No. N62474-89-D-9295. September 1998.
- Pacific Northwest Regional Extension Bulletin (PNW). 1995. High Yield Hybrid Poplar Plantations in the Pacific Northwest. PNW 356.
- TEC LTM Team. 2004. Phytoremediation Inspection and Monitoring Report, January 2004; Area 1, Operable Unit 1, Naval Undersea Warfare Center Keyport, Washington. Prepared by The Environmental Company, Inc. and CH2M HILL.
- USDA (United States Department of Agriculture). 1989. A Guide to Insect, Disease, and Animal Pests of Poplars. Agricultural Handbook 677.

APPENDIX A
TREE PLANTATION LAYOUT DIAGRAMS

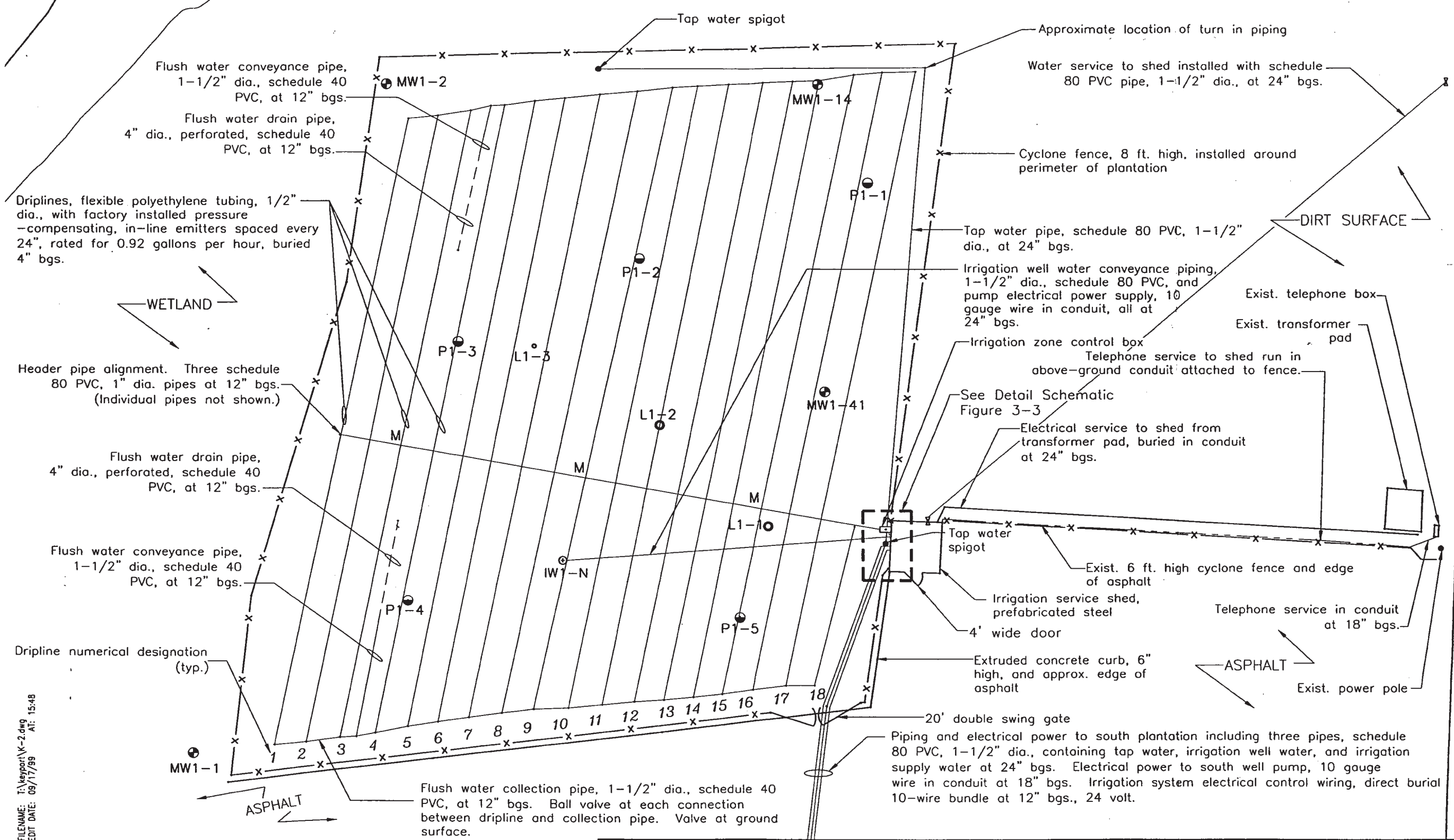

FILENAME: T:\Keyport\K-2.dwg
 EDIT DATE: 09/17/99 AT: 15:48

Notes:

- Installed PVC piping and polyethylene tubing is flexible, and was not laid in precisely straight runs as sometimes shown on this plan.
- Area of north plantation is 0.87 acres.
- Approximate 545 trees planted, in rows 12" to 18" from each dripline.

Source: URS (1999)

LEGEND	
P1-2	Piezometer Location
IW1-N	Irrigation Well Location
MW1-2	Monitoring Well Location
M	Moisture Sensor Probe Location
L1-2	Lysimeter Location

CLEAN
 COMPREHENSIVE LONG-TERM ENVIRONMENTAL ACTION NAVY

FIGURE 4
**As-built Plan View
 North Plantation Phytoremediation at OU1**
 NUWC Keyport, Washington

SCALE IN FEET

CTO 0237
 NUWC Division Keyport
 Keyport, WA

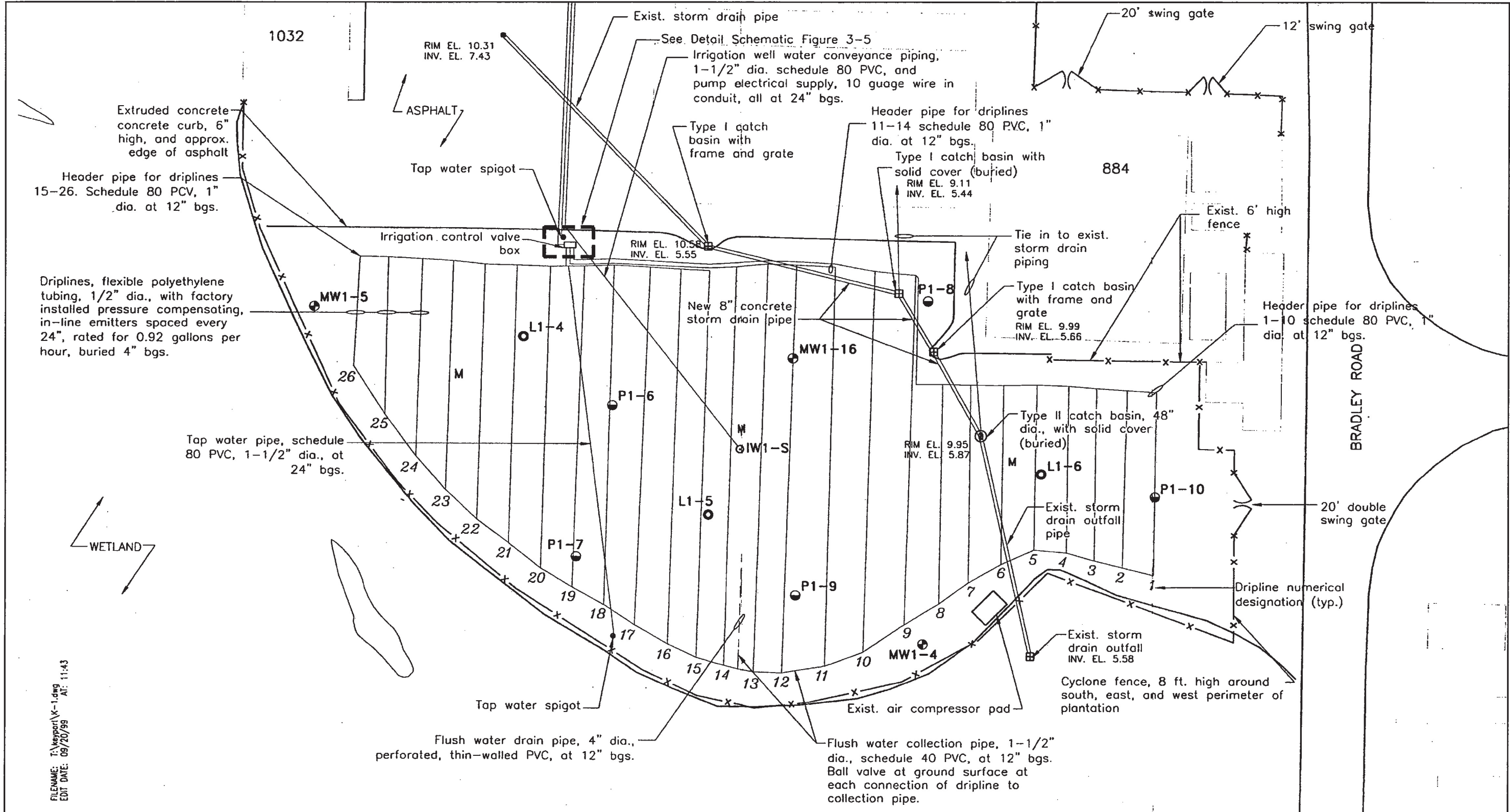

FILENAME: F:\Keyport\K-1.dwg
 EDIT DATE: 09/20/99 AT: 11:43

- Notes:**
- Installed PVC piping and polyethylene tubing is flexible, and was not laid in precisely straight runs as sometimes shown on this plan.
 - Area of south plantation is 0.71 acres.
 - Approximate 358 trees planted, in rows 12" to 18" from each dripline.
 - See Washington State Department of Transportation Standard Plans for description of catch basin types I and II.

Source: URS (1999)

LEGEND	
P1-2	Piezometer Location
IW1-N	Irrigation Well Location
MW1-2	Monitoring Well Location
M	Moisture Sensor Probe Location
L1-2	Lysimeter Location

FIGURE 5
As-built Plan View
South Plantation Phytoremediation at OU1
 NUWC Keyport, Washington

CLEAN
 COMPREHENSIVE LONG-TERM ENVIRONMENTAL ACTION NAVY

0 15 30
 SCALE IN FEET

CTO 0237
 NUWC Division Keyport, WA

APPENDIX B
FIELD PROCEDURES AND FORMS

B.1 WELL REDEVELOPMENT

Well redevelopment will be conducted in accordance with the following steps:

1. Calibrate field instrumentation for measurement of water parameters, including pH, temperature, dissolved oxygen, oxidation reduction potential, specific conductivity, and turbidity. See Field Procedure A.12 Water Quality Meter Calibration (MMA SAP, Navy 2018c).
2. Prior to commencing the redevelopment activities, the well will be opened and the depth to water and the depth to bottom will be measured. Monitor breathing zone and well with PID. See Field Procedure A.1 Water Level Measurement (MMA SAP, Navy 2018c).
3. Begin development of well by mechanically scrubbing and surging with alternating use of wire brush and surge block, or both in tandem, to loosen fouling and encrustation with a bristled brush sized to the casing. Brushing and surging will be performed throughout the water column of the well, with particular effort concentrated in the screened interval to remove silt and restore the specific capacity.
4. The well will then be pumped using a peristaltic pump or submersible pump to remove sediment. Ideally, the maximum purge rate should be equal to the recharge rate without drawing down the water level below the top of the screen.
5. Field parameters will be monitored to confirm development and this information will be logged in logbook and/or well redevelopment form.
 - a. Logged information will include the date, well ID, total quantity removed, static water level before development, total depth of the well observed (initial and ending), volume of water in the well prior to development (2" well = 0.6 liters/foot and 4" well = 2.5 liters/foot), the surge/development method, the pumping method, the flow rate, and periodic measurements are collected for depth-to-water, volume removed, color/clarity/odor and the following six field parameters: pH, temperature, dissolved oxygen, oxidation reduction potential, specific conductivity, and turbidity.
6. Redevelopment and/or purge water will be temporarily stored on-site in 55-gallon drums until removed from the site by the waste disposal company.
7. Repeat surging and pumping for several cycles until improvement is observed; avoid surging during the last portion of development.
8. Continue development of well until discharge is clear and parameters have stabilized for three consecutive readings (pH \pm 0.5 standard units, specific conductivity \pm 10%,

and turbidity \pm 10% or turbidity below 10 NTUs). There are no stabilization criteria for the other parameters. Alternatively, the well is considered developed when at least three well volumes have been removed and turbidity is below 10 NTUs.

***NOTE – Redevelopment activities will be performed for a minimum of 45 minutes and up to two hours per well. Ideally, redevelopment activities will continue until turbidity is \leq 10 NTUs.**

****Only 1-55 gallon drum of development water (includes groundwater, decontamination water, sediment, and purge water collected for water quality parameters) will be collected per well****

9. Remove development equipment and decontaminate. See Field Procedure A.11 Decontamination of Field Instrumentation (MMA SAP, Navy 2018c).
10. Document activities in the logbook and/or well redevelopment form. See Field Procedure A.10 Site Logbook (MMA SAP, Navy 2018c).

KEYPORT PHYTOREMEDIATION MONITORING
INSPECTOR'S DAILY LOG

Location: North Plantation South Plantation **Task Order/Date:** _____

Reason for Inspection: Monthly Inspection Fertilization Weed Control Pest Control Irrigation Thinning and Pruning Field Meeting Other _____

Inspection Attendants: _____

Specific Inspection Activity: _____

Inspection Results: _____

Physical damage from animals or humans: _____

Insect damage: _____

Water stress: _____

Nutrient stress: _____

Disease damage: _____

Further Action Recommended: _____

Inspector: _____

Sheet ___ of ___

TIDE GATE INSPECTION AND MAINTENANCE FORM

Keyport OU 1 Tide Gate at Tide Flats

Inspectors: _____ Task Order: _____

Date/time: _____

Tidal Condition: _____

Weather Condition: _____

FIELD INSPECTION

1) Any visible damage to the tide gate, concrete collar and/or the culvert? ___ Yes ___ No

If yes, describe damage and recommended action(s):

2) Are the back floats in good working conditions? ___ Yes ___ No

If not, describe problem and recommended actions: _____

3) Inspect the condition of the vacuum break vent. Describe condition and recommended action(s):

4) Are all moving parts of the tide gate in good working orders? ___ Yes ___ No

If no, describe the condition and recommended action: _____

5) Are plastic isolation sleeves and washers at contact points in good conditions? ___ Yes ___ No

If no, describe condition and recommended action(s)

6) Is the security gate at upper end of culvert in place and without damage?

___ Yes ___ No If no, describe recommended action _____

FIELD MAINTENANCE

Were field maintenance actions required during this inspection? ___ Yes ___ No

If yes, continue to complete the rest of the form.

11) Describe the maintenance action(s) conducted:

Inspector's Signature

Date

FOLLOW-UP REPAIR AND/OR RE-INSPECTION

Do the inspection and field maintenance actions require repair and re-inspection at a later date?

Yes ___ No ___ If yes, describe the follow up action and resolution:

Repair and/or Re-inspection conducted by:

Organization

Signature

Date

APPENDIX C
PHOTOGRAPHS OF THREATS TO TREE HEALTH



Healthy Tree

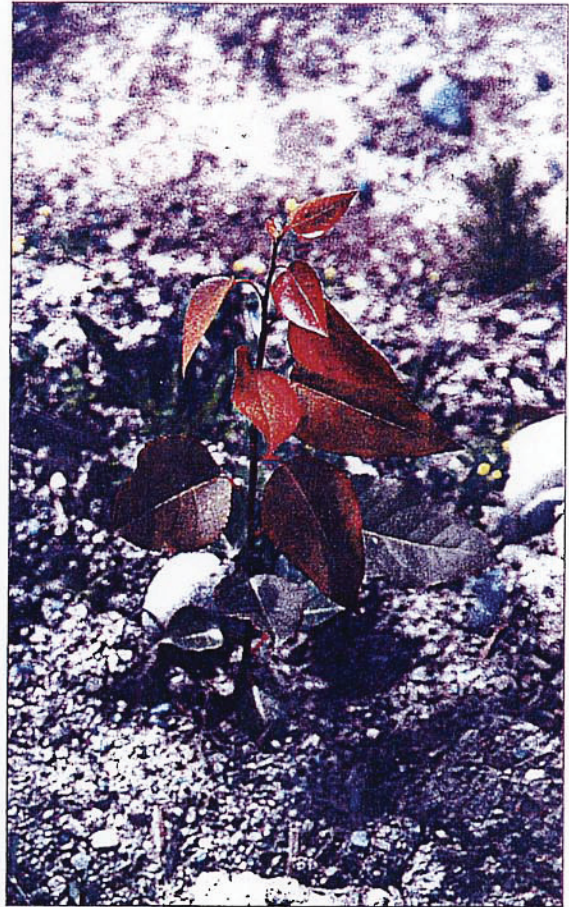

Nitrogen-Deficient Tree



Standing Water-
Submerged Tree
Roots

U.S.NAVY

Figure B-1
Photographs of Threats to Tree Health

Delivery Order 0021
NUWC Division Keyport
Keyport, WA
PHYTOREMEDIATION O&M PLAN



Tent Caterpillar Nest



Girdling of a Tree Trunk Below Soil Line by Voles



Wind Damage - Broken Main Leader

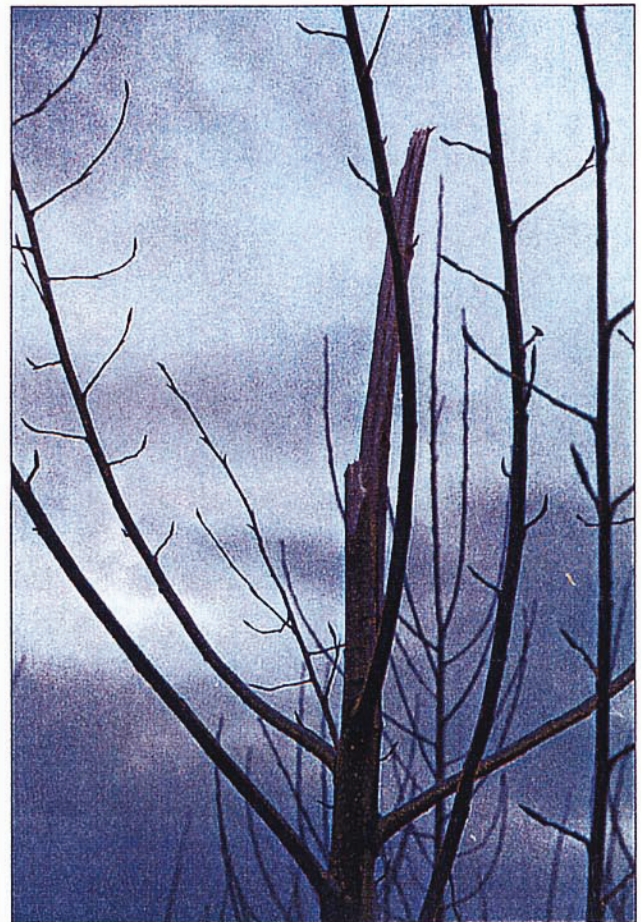

Wind Damage

U.S.NAVY

Figure B-2
Photographs of Threats to Tree Health

Delivery Order 0021
NUWC Division Keyport
Keyport, WA
PHYTOREMEDIATION O&M PLAN



Weeping Indicating Early Evidence of Stem-Borer



Damage from Stem-Borer Insect

APPENDIX D

**TIDE GATE OPERATION AND MAINTENANCE MANUAL AND
DRAWINGS**



OPERATION AND MAINTENANCE MANUAL

FOR:

SELF REGULATING TIDE GATE

FOR:

**NAVAL UNDERSEA WARFARE CENTER
KEY PORT, WA**

**MANUFACTURED BY: WATERMAN INDUSTRIES, INC.
25500 ROAD 204
EXETER, CALIFORNIA 93221
PHONE: (559) 562-4000**

REF: WATERMAN JOB # L- 4551

**SERVICE: ARRANGED THROUGH THE FACTORY
PHONE: 559-562-4000
FAX: 559-562-2277
CONTACT: Drew Persson**

OPERATION AND MAINTENANCE MANUAL
TABLE OF CONTENTS

<u>INTRODUCTION</u>	<u>PAGE #</u>
FOREWORD	1.0
RECEIVING	1.1
HANDLING AND STORAGE	1.2
SPECIAL TOOLS	7.0
SPARE PARTS	7.1
FIELD SERVICE AND FIELD SERVICE CHARGES	8.0
LIMITED WARRANTY	9.0
<u>INSTALLATION ON RUBBER GASKET</u>	11.7.1
<u>OPERATING PRICIPLES</u>	11.7.3
<u>ADJUSTMENTS</u>	11.7.5
<u>INSPECTION AND MAINTENANCE</u>	11.7.7
<u>ENGINEERING DRAWINGS</u> (WATERMAN SUBMITTAL DRAWINGS)	
36" SELF REGULATING TIDE GATE	RC-99-0697

WATERMAN INDUSTRIES, INC.

FOREWORD

The purpose of this manual is to provide information to the engineers, contractors, plant operators and associated personnel involved with the installation, operation and maintenance of equipment supplied by WATERMAN INDUSTRIES, INC. for this project. Although every care is taken in our factory to ensure top quality equipment, we cannot be responsible for damage caused by negligence after shipping. Therefore, described herein are WATERMAN'S recommended methods of handling, storage, installation, adjustment, and initial operation for standard situations to be used in conjunction with the approved installation drawings provided by WATERMAN INDUSTRIES, INC. If proper care and accuracy are exercised in the field when installing our gates, they will operate as designed at maximum efficiency.

WATERMAN INDUSTRIES, INC.

RECEIVING

CHECK COUNT all parts when you receive shipment. All individually shipped parts or assemblages are listed on the packing list(s). Should a shortage exist, notify WATERMAN INDUSTRIES, INC. immediately. We cannot be responsible for any shortages reported more than 30 days after receipt of shipment. Special care should be taken in accounting for and safely storing all bolts, nuts, and small items which are often misplaced at jobsites.

Unless your contract with WATERMAN INDUSTRIES, INC. states otherwise, all equipment is shipped F.O.B. factory. If any equipment has been damaged in transit, the purchaser will be responsible for filing claim with the transportation company. For assistance in filing any claim and/or replacing equipment, please contact WATERMAN INDUSTRIES, INC. directly.

WATERMAN INDUSTRIES, INC.

HANDLING AND STORAGE

All WATERMAN gates and appurtenances are precision machinery and should be handled accordingly. While all parts are of rugged design, it is never the less possible to warp machined surfaces, stems, etc., through improper storage and handling. To avoid all problems of this nature we recommend the following:

1. Lift gates through stem hole in top of lift nut box on cover only when shipping stops are in place, taking particular care of wedges and seats.
2. Support full length of stems at all times, being sure not to damage threads.
3. Store equipment on an even, clean, dry surface to prevent distortion.
4. Cover all equipment to protect machined surfaces.
5. **DO NOT** stack equipment without protection and proper spacers.
6. Handle lifts as you would any precision machinery.



SPECIAL TOOLS

The installation and adjustments of Waterman gates and equipment requires no special tools and can be accomplished using a minimum of the following standard tools:

10" or 12" Crescent Wrench (2 required)

1/2" or 5/8" Allen Wrench

.004" Feeler Gauge

While these are the minimum tools required, installation time can be greatly decreased with such standard tools as socket wrenches and box wrenches.

If electric motor operated lifts, or cylinder operators are supplied, see separate manufacturer's Operation and Maintenance manual for special tools.



SPARE PARTS & PARTS REPLACEMENT

All products supplied by Waterman Industries, Inc. are designed to last indefinitely if properly maintained and operated, therefore, no spare parts are recommended.

Should it become necessary to replace a part, refer to the enclosed installation or detail drawings for the appropriate parts number or size. Replacements may be ordered direct from the factory or through your local representative. Always be prepared to give the Waterman Job number and installation drawing number. (see "Field Service", Pg. 8.0).

(If certain spare parts were required by project specifications, they will be listed on sheet 7.1, under "Spare Parts Addendum").

Replacement parts for "vender supplied" products, i.e. motorized operators, hydraulic cylinders, etc. should be ordered as recommended in separate manufacturers O & M data located elsewhere in this manual.

WATERMAN INDUSTRIES, INC.

FIELD SERVICE

When trouble develops either in the installation, operation, or performance of the equipment, the installation manual and drawings should be checked to determine if the equipment has been installed properly. If proper performance and operation cannot be obtained, and assistance from the factory is desired, please contact the factory and **REFERENCE THE JOB NUMBER, L-4551** so that we may locate the project records and better assist you. Our company may be contacted at:

WATERMAN INDUSTRIES, INC
P.O. BOX 458
EXETER, CALIFORNIA 93221

PHONE: (559) 562-4000
FAX: (559) 562-2277

Arrangements may be made to send a representative to the jobsite if this is required. If the equipment is faulty in workmanship or material, the necessary repairs or adjustments will be made by the factory at no cost to the purchaser. If, however, the problem is due to faulty installation or adjustment, the cost of the field service will be charged to the purchaser.

If repairs are made in the field by the purchaser or authorized by the purchaser, back charges for these repairs will **NOT** be accepted by the company unless the company has been notified prior to the incurring of these costs and has accepted the responsibility for these repairs. **ANY UNAUTHORIZED REPAIRS OR CHANGES TO EQUIPMENT WILL AUTOMATICALLY VOID WARRANTY.**

The company will not be liable for contingent costs or costs of delay due to the faulty equipment and the repairs thereof.

FIELD SERVICE CHARGES

Field service charges begin from the time of departure until the return of the service man and include a daily rate plus travel and subsistence expenses. Premium day and hourly rates will be charged on Saturdays, Sundays, and Holidays and for time spent before 6 a.m. or after 5 p.m. or over eight (8) hours per day. A schedule of Field Service charges can be obtained by calling Waterman Industries, Inc.

If service personnel are required for equipment produced by another manufacturer (i.e. for electric Motor operator), that manufacturer's standard service charges will prevail.



LIMITED WARRANTY

Every effort is made to assure the highest quality merchandise, free of any defects, which is warranted against defects in material and workmanship when used in accordance with the standards and/or instructions recommended by this catalog or other written quotation of this firm, but no warranty, expressed or implied, is made other than as follows:

Products manufactured by Waterman Industries, Inc. are warranted against defects in materials and workmanship for (18) eighteen months after shipment or (12) twelve months after installation, whichever occurs first and such warranty can only be enforced by the original consumer purchaser. During the warranty period, the product will be repaired or replaced at Waterman Industries, Inc.'s option at no cost to the purchaser.

Measure of damage is the price of defective material only. No charges for labor or expense required to remove or replace defective material or for any consequential damages will be allowed. Warranty excludes damage due to misuse, neglect or misapplication.

Any implied warranty of merchantability of fitness is limited to the duration of this written warranty. To the extent allowed by law, neither Waterman Industries, Inc. nor its selling dealer or agent shall have any responsibility for loss of use of the product, loss of time, commercial loss or consequential damages.

In the event a warranted product is believed defective, notify your Waterman Sales Office and furnish date purchased, copy of invoice or shipping documents. **DO NOT** attempt repairs or returns without authorization from Waterman Industries, Inc. Unauthorized repairs may void warranty, and costs for unauthorized repairs performed or replacement parts purchased within the warranty period will not be reimbursed. A return authorization number must be obtained from Waterman Industries, Inc. prior to returning any merchandise.

Some states do not allow limitations on how long an implied warranty lasts or the exclusion or limitation of consequential damages, therefore the above limitation may not apply to you.

This warranty gives you specific legal rights, and you may also have other rights which vary from state to state.

It is the policy of this company to encourage the settlement of disputes in an informal manner, and if such disputes arise over a warranty claim an informal dispute settlement mechanism can be agreed upon at that time.



INSTALLATION INSTRUCTIONS

Self-Regulating Tidegate Assembly Mounted on Rubber Gasket

For these instructions refer to the Waterman Submittal Drawing #RC-96-1339 Pages 1 and 2 located in the Engineering Drawing section in the back of this manual.

1). Mount Frame to Wall and to Front Pedestal Support

- a) Install anchors (all) in pattern as noted on submittal drawing, Detail marked REAR FLANGE.
- b) Install front pedestal concrete anchors in pattern as noted on submittal, Detail Section C. On front pedestal support anchors install studs, one (1) hex nut, metal washer and isolation washer.
- c) Place rear gasket over bolts.,. Lift frame assembly over bolts using two (2) angle welded at near top curve of gate. (Do not use slotted holes.) Loosely mount frame and rear gasket and install isolation sleeve, metal washer, plastic washer, and hex nut on each anchor bolt, Detail H.
- e) Adjust nuts, front and sides, as required to bring front of gasket face and vertical support tubes into alignment. Check with carpenters level. Detail Section C and H. Centerline of tubes should be vertical in both planes. The closer to true vertical the better the gate operation.
- f) After gate frame and seat are aligned, tighten bolts to provide a snug fit of the rear gasket to the concrete wall without distorting the shape of the gasket. Grout between frame and front pedestal support at this time.

2.) Assemble Door to Frame.

- a) Mount two (2) ½" diameter lifting eyes with nuts and washers into two (2) holes in top of cross bar of cover weldment. Lift cover assembly vertically and place outer arms between flanges of frame pivot supports . Align pivot hole in cover weldment and slots on frame pivot support.
- b) With door assembly in vertical position, connect door assembly to frame assembly with pivot pin, installing centering washers and spacer washers as pin passes through parts. Secure pin in place with collar and cotter pin, Detail A, B, and G.
- c) Check seating of door assembly to frame assembly gasket. There should not be any gaps greater than .010 inches when face plate of door weldment is pressed against gasket.
- d) Pull down on rear cross member of door weldment to insure cover rotates freely up to horizontal position. Brace cover full open (horizontal position) using timbers.



3.) Assemble Back Float Assembly to Frame Assembly:

- a) The back float assembly may be mounted along the side channels, or back cross channel of the frame weldment. The exact location will be determined by clearance and required force to close the cover depending on tides. (See section on back float adjustment.)
- b) The back float bracket has a bar with a lip, Section F. This bar and lip should be slipped over the channel protruding out from the top of the bracket, where it will hold the bracket in place until it is bolted to the frame. For installation along the sides, there is sufficient clearance between the channel and the lower float release rod to insert this bar.

4.) Installation of Vacuum Break Vent:

- a) Bolt Vacuum Break Vent to collar insuring sloped top is orientated with respect to gate as shown on submittal drawing. Interference with gate operation could occur if it is not properly orientated. Bolt .



OPERATING PRINCIPLES

- 1) Using the "moments of force" principle, the Self Regulating Tide (SRT) gate relies on the adjustment of float buoyancy and float position to achieve the weights and balances required for proper closing and opening of the gate at any desired water level within its normal range of operation.
- 2) When adjusted properly (by pouring the required amount of water or anti-freeze into the door float to achieve a dynamic equilibrium around the hinge point), the door float will just lift the gate open with an in-coming tide, yet cause the gate door to close if the back float brackets are removed. By raising the door float, the incoming tide water will lift the gate door to a horizontal position, and may entirely submerge the SRT. However, the submerged gate door will remain open, allowing water to flow through the pipe to the interior wetland area until the rising tide reaches the back floats. The floats then lift the door arms causing the gate door to drop into the water current. The current carries the door closed. The door will remain closed until the tide recedes. As the tide recedes, the hydrodynamic head reverses. The gate door will open and the interior wetland water drains out through the SRT. The gate door will rotate lower as it floats on the surface of the receding tide water. The gate door will not close against an in-coming tide unless and until the predetermined water level is reached which will activate the back floats.
- 3) The SRT is not a water tight system nor is it intended to be because it must allow entry of water and air through the vacuum break when the gate door closes. While much smaller in size than the gate opening and several feet higher, this secondary opening is necessary because abrupt closure of the gate door will cause an immediate partial evacuation of the pipe followed by a back and forth movement of pipe water. This motion creates a hydrodynamic head inside the SRT, tending to reopen the gate door prematurely. To prevent premature gate door opening, the SRT is fitted with two (2) vertical floats located in a housing immediately behind the hinge pins, and beneath the arms of the gate door. When the gate door is closed and the door arms pivot to a vertical position, the two floats rise vertically behind the door arms as blocks to prevent the gate from reopening until the receding tide allows the vertical floats to drop back into their neutral position. The buoyancy of these vertical floats is adjusted with water or anti-freeze so that the head of the float rises to approximately one and one-half (1 ½) feet above the door hinge pins at the time the gate door closes. If the rear ball floats are readjusted to close the gate at a different water level (higher or lower), the vertical floats may also need to be readjusted for proper buoyancy by draining or adding anti-freeze.
- 4) If the gate door is closed and the water level behind the SRT, (i.e., within the protected wetland area.), is higher than the water level on the front side of the gate, and the vertical floats are in the raised position, the gate door will try to open with the reverse hydraulic head, but will be prevented from doing so by the blocking action of the vertical floats in their raised position. The water pressure on the inside face of the gate door will be transmitted, through the door arms to the vertical floats. This pressure keeps the floats "locked" in position until the pressure on the door is released. This is achieved automatically by releasing water through the large lateral doors on each side of the SRT. When the head has equalized enough to relieve the pressure on the vertical floats, they will drop to their neutral position and the door is allowed to open. In the event that the discharge water pressure on the gate door is not reduced to a point which allows the vertical floats to drop down from their raised position at low tide, the next in-coming tide will push the gate door closed and release the vertical floats. The gate door will then pivot open on the in-coming tide.



- 5) The opening and closing of the gate door on alternate tides is often associated with installations where the SRT is located within an inter-tidal zone where the hinge elevation of the SRT is below the design high water elevation of the protected wetland area, or where a relatively large upland watershed constantly discharges freshwater to the wetland in addition to the water introduced by tidal action. In either case, the net result is wetland water level of elevation greater than the outer SRT hinge elevation.

At this point, if the gate door closes, the vertical floats rise up behind the hinges locking the gate door, preventing it from opening until the water level drops. With the dropping water level the vertical floats release and reopening the door on alternate tides. If undesirable, this mode of gate operation can be eliminated by installing properly-sized parallel pipes with one-way flap valves to drain the upland runoff component of the marsh water in addition to the SRT which handles the tidal component of flow. Alternately, the SRT can be located within the inter-tidal zone so that the level of the SRT hinge pins are at or above the design high tide elevation of the marsh side of the SRT.

- 6) Once properly adjusted for normal operation, the net buoyancy of the door float will allow the gate door to rise and fall with the tide, opening and closing depending on the ambient water level acting on the float system. If at this point of balance, either the door float or the back float brackets are removed, the gate will be swept closed with the incoming tides and will remain closed, acting like a conventional flap or tide gate. This conservative design feature greatly diminishes the potential for flood damage and enhances inspection and maintenance of the interior of the gate-wetland system. When the floats are reattached, the gate can again respond to rising and falling tides.



OPERATIONAL ADJUSTMENT OF THE SELF-REGULATING TIDEGATE

General

The SRT is literally “tuned” for proper operation over several tidal cycles by incrementally adjusting the relative position and buoyancy of its float systems in overlapping steps that eventually converge on, the float setting for the desired water closing elevation. The back float assembly will be adjusted by altering its position on the gate with respect to the door hinge and water elevation at time of closure.

Float Adjustment

- 1) The position of the back float assembly is adjusted first, followed by adjustment of the door float and finally the vertical floats. The back float may be adjusted in any of three (3) ways:
 - a) The position of the ball float on its float tube is adjusted by relocating the float pin in one (1) inch increments along the tube, sliding the ball float to its desired position, and then reopening the plate washers above and below the ball on the ball float tube.
 - b) The position of the ball float on the back float bracket may be adjusted by placing stop bolts in any desired hole of the radius plates so as to restrict the arc of the float tube as it is lifted by the ball float with the rising tide. The stop bolt function is to provide an upper and lower limit beyond which the tube will be prevented from rotating.
 - c) The position of the back float bracket (and attached float tube and ball float) may be adjusted by placing the brackets over the door arm channels, sliding the bracket to any desired position, and then fixing it in position by bolting it through the two (2) matching bolt holes. In addition to the door arm channels, and to achieve the highest tidal elevations before the floats close the gate door, the float brackets may also be bolted to the cross-arm channel so that the ball floats will pass evenly between the door arm channels and the vacuum break when the door closes to a vertical position.

To save time tuning the gates in a multiple gate installation it is recommended that multiple float adjustments be made at different positions on the back float tube, bracket, and position on the arms of different gates. Make sure the float balls will not contact the vacuum-break vent at any point of travel.

On alternate tidegates the ball floats should be pinned at varying positions along the tubes from the lowest to the highest hole settings available. For any individual gate, maintain the same relative position settings for both ball floats on the assembly.

After making these float settings, monitor gate operation and relocate float position as necessary to obtain the required float system configuration for the desired water elevation at gate closure.



- 2) After roughly adjusting the ball floats, the door float (located along the bottom of the door front) is adjusted by adding anti-freeze through the fill hole and then resealing the fill-bolt threads with a Teflon plumbers' pipe thread compound before inserting and tightening the fill bolt. The volume of anti-freeze to be added is the amount which will cause the gate door to sink and close with the incoming tide when the ball float brackets have been removed. The fill hole on the door float is positioned by design so that when anti-freeze is added to fill the short end of the float up to the fill hole, then the door float will be approximately neutrally buoyant with the ball floats attached.

This will provide a beginning point for achieving the desired buoyancy of the door float. Keep in mind the fact that, as the door float becomes heavier with added anti-freeze, the resistance to closing decreases. A compensating adjustment of the back floats is usually required, and may be achieved by resetting the ball float to a lower position (closer to the hinges).

- 3) Adjustment of the two (2) vertical floats involves pouring enough anti-freeze into the fill hole, and pouring out any excess, so as to ensure that the vertical float rises approximately 18 inches above the hinge pins when the gate door closes at the desired water elevation, and then resealing the fill bolt threads with a Teflon plumber's pipe thread compound before inserting and tightening the bolt. At the water elevation intended for gate closure, the properly-adjusted vertical float may range from being submerged below several feet of water, to having its top extending up to 18 inches out of the water. It doesn't matter if the vertical float is above the water surface or totally submerged, so long as the vertical float serves its functions of preventing the gate door from reopening after its initial closure, and subsequently dropping out of its blocking position as soon as possible on the receding tide, so as to allow the gate door to swing fully open to discharge water.

When the SRT is located in the inter-tidal zone so that the vertical float will be submerged even after it has floated up as high as possible the vertical float should be adjusted by adding anti-freeze so that the top of the vertical float extends only one (1) to two (2) inches above the surface of the water when the vertical float is freely floating with the rising tide. This setting will allow the vertical float to achieve its maximum 18 inches extension when the gate closes, yet it will immediately drop out of blocking position with the receding tide when the outer and inner pipe water levels reach equilibrium and the head reverses, thereby opening the gate door.

If a different gate closing water elevation is desired at some time in the future, it is achieved by resetting the back floats and adding or removing anti-freeze from the door float, then you must determine by observation whether or not the buoyancy of the vertical floats must be readjusted accordingly.



INSPECTION AND MAINTENANCE

- 1) Inspection and maintenance of the gate should be conducted periodically to ensure proper functioning of the gate. Verify opening and closing of the gate at the water levels intended and insure free rotation of the back floats and lateral doors, remove fixed debris, clear any obstructions of the vacuum break, and check range of motion of the vertical floats.
- 2) Frequency of inspection and maintenance varies with each site and tidal regime. It is influenced by relative exposure to storms, ice and floating debris, marine fouling organisms and vandalism. As a minimum quarterly inspections are recommended.
- 3) Cleaning of the gate should be conducted with a hand scraper or power washer to remove bio-fouling and accumulated sediment only if they interfere with gate operation or designed conveyance of water in the pipe. It is not unusual for a marine fouling community to develop inside the culvert pipes behind the SRT and this fouling may have to be removed periodically. The bio-fouling community develops quickly to a robust covering of the pipe interior when the isolated wetland is initially restored and nutrients are mobilized on a grand scale. With continued flushing of the wetland system nutrient contribution is reduced and so too the dependent marine fouling community.
- 4) Painting of the gate assembly is not necessary. Individual parts are shop coated with primer and anti-fouling paint to inhibit bio-fouling of moving parts and floats. If bio-fouling subsequently poses a problem, e.g., to the vertical floats and their action in rising and falling within their housing, these gate components may be individually repainted as necessary. Different parts of the gate will normally support a scattered assemblage of sea weeds, barnacles and mussels with no adverse effects on gate operation. Large bio-fouling communities could affect the weights and balances of the floats and require cleaning of the gate system.



FOSTER WHEELER ENVIRONMENTAL CORPORATION

July 8, 1999
FWBEL-RACII-99-1628

Mr. Drew Persson
Project Manager
Waterman Industries, Inc.
25500 Road 204
Exeter, California 93220

**Subject: Vendor Drawing Review - Self-Regulating Tide Gate
(Waterman Job #L-4551)
Delivery Order 61 - Sediment Removal and Tide Gate Upgrade
Naval Undersea Warfare Center Division, Keyport, Washington**

**Reference: Contract N44255-95-D-6030, Environmental Remedial Action Contract
for Sites in Washington, Oregon, Idaho, Montana and Alaska**

Dear Mr. Persson:

The following information/comments are provided in response to your letter of June 15, 1999 and vendor drawing review.

1. Invert elevation will be 0.0 (zero).
2. The high water elevation will be approximately 2.5 to 3 feet. Adjustment on either side of this range is required. It is my understanding that based on the configuration shown on the drawings, the gate can be adjusted to close at a water level ranging from 1.86 ft. to 5 ft. above invert. These operating parameters will meet our clients needs.
3. The gate will be secured to a concrete head wall using stainless steel anchor bolts. It will not be attached to the 36" diameter CMP, which will be installed flush with the face of the wall. Based on our earlier conversation, information regarding wall thickness is not required.
4. A 12 bolt / 46" bolt circle diameter arrangement is required, as specified in the written order. The larger bolt circle diameter is required to provide clearance for installation of concrete reinforcing steel between the CMP and the anchor bolts. In an earlier conversation, Gary Tuttle indicated that this would not present a problem.

5. The paint system noted on the drawings is acceptable. The desired color is gray.
6. It is our intention to not install front supports as recommended in Section C. According to Gary Tuttle, this would be acceptable based on the relatively limited size and weight of the gate required for our application.

If you have any questions or concerns regarding the above, please contact me at (360) 697-6530.

Sincerely,

A handwritten signature in black ink, appearing to read "L. Boreen", with a long horizontal flourish extending to the right.

Lee Boreen

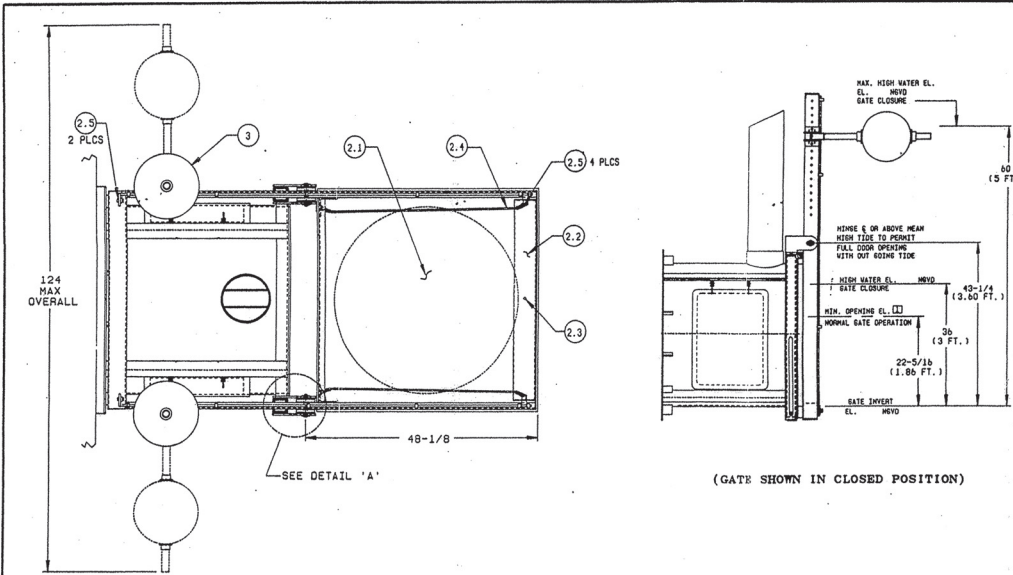

(GATE SHOWN IN CLOSED POSITION)

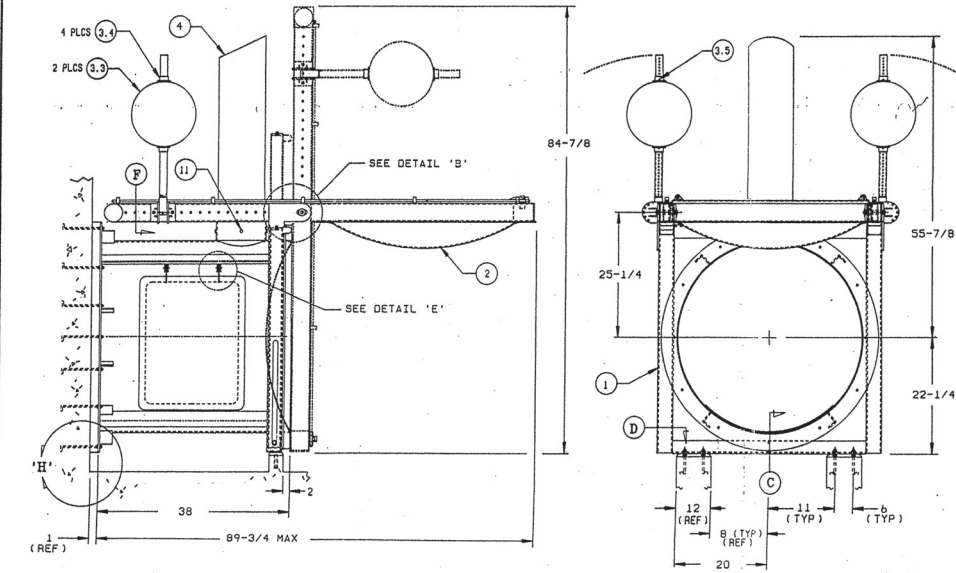

MATERIAL KEY		FINISH KEY		PAINT KEY		
16. STAINLESS STEEL, 1/2" ASTM A-167 TYPE 304	2. MILL			M. LIGHT SANDBLAST		
18. STAINLESS STEEL, 1/2" ASTM A-167 TYPE 316	3. MILL			PAINT (1) CT (5 MILS)		
19. COPPER BRASS, ASTM C9000				PRIMER 400 SPIRIT		
15A. STAINLESS STEEL HARDWARE: F-303 AND 304				COLORLIT. BLUE R11705		
17. ALUMINUM, ASTM B-201, B-201 AL., 6061-T6						
18. ALUMINUM PIPE, ASTM B-201, 6061-T6						
21. 3MM POLYETHYLENE PLASTIC						
27. SILICON BRONZE, ASTM B-19 AL. 85% ON 85%				M. LIGHT SANDBLAST		
34. PVC PLASTIC				SPECIAL, MARINE ANTI-FOULING		
42. LIPOLYMER, W. POLYURETHANE FOAM				PAINT SYSTEM		
44. WEHMAK						
46. FIBERGLASS, THE 3MP, PLASTIC						
50. FIBERGLASS						
ITEM	ITEM DESCRIPTION	MATERIAL KEY	FINISH KEY	PART NO. OR SIZE (FOR WATERMAN USE ONLY)	QTY/ GATE	TOTAL QTY.
1.1	FRAME ASSEMBLY	17	2,3	PER 107035	1	1
1.2	LATERAL DOOR	17	3K	PER 107034	2	2
1.3	BUSHING	35	2,3	.54 ID X .84 OD X 3/8 LG	2	2
1.4	SHOULDER SCREW	9A	2,3	1/2 DIA X 1-1/2 LG; THRD 3/8NC	2	2
1.5	WASHER	15A	2	1/2 DIA	4	4
1.6	WASHER	21	2	1/2 DIA	4	4
1.7	HEX NUT, WASHER, LOCKWASHER	27, 15A	2	3/8 NC; 3/8 DIA; 3/8 DIA	2ea	2ea
1.8	VERTICAL FLOAT	17	ML	PER 107037	2	2
1.9	PIPE FLUG	9A	2	3/4 NPT HEX HEAD	2	2
1.10						
1.11						
1.12	FLOAT PIN	9A	2,3	1 DIA (REF); PER 107042	2	2
1.13	BUSHING	35	2,3	1 DIA SCH'L HD PIPE X 4-1/4 LG	2	2
1.14	COLLAR	9B	2,3	PER 108334	2	2
1.15	WASHER	21	2	1 DIA 1 1/16 THK	2	2
1.16	COTTER PIN	9A	2	1/8 DIA X 2-1/2 LG	1	1
1.17	FRONT GASKET	44	2,3	PER 107030	1	1
1.18	WASHER	21	2,3	3/8 DIA	10	10
1.19	HEX HEAD BOLT	15A	2	3/8 NC X 2 LG	10	10
1.20	WASHER	15A	2	3/8 DIA	10	10
1.21						
1.22	HEX NUT, SELF-LOCKING	15A	2	3/8 NC (NY-LOC)	10	10
1.23	ISOLATION SLEEVE	35	2	.54 ID X .84 OD X 5/16 LG (Z)	10	10
1.24	WASHER, LARGE O.D.	15A	2	3/8 DIA (1-1/4 OD)	10	10
1.25						
1.26						
2	DOOR ASSEMBLY	17, 30, 9A	AK, 2	PER 107031	1	1
2.1	COVER	17	ML	PER 107038	1	1
2.2	DOOR FLOAT	17	2	3/4 NPT HEX HEAD	2	2
2.3	PIPE FLUG	9A	2	1/8 DIA (REF); PER 108320-3	1	1
2.4	ATTACHING CABLE	9A	2	1/8 DIA (REF); PER 108320-3	2	2
2.5	HEX HD SCREW, WASHER, LOCKWASHER & NUT	15A, 27	2	1/4 NC X 1 LG	8ea	8ea
2.6	FLOAT RELEASE ROD	17	2,3	PER: 108379-3	2	2
2.7	SPRING PIN	9A	2	3/16 DIA X 1-1/2 LG	2	2
2.8	BUSHING	46	2,3	16US MS1-1210-20	4	4
3	BACK FLOAT ASSEMBLY					
3.1	BACK FLOAT BRACKET	17	2,3	PER 107033	2	2
3.2	ELOAT ARM	17	2,3	PER: 107034	2	2
3.3	FLOAT	43, 25	2,3	PER: 123327-2	2	2
3.4	FLOAT STOP	17	2,3	PER: 108300-2	4	4
3.5	COTTER PIN	9B	2	1/4 DIA X 2 LG	4	4
3.6	HEX HD BOLT, WASHER, LOCKWASHER, & HEX NUT	15A, 27	2	1/2 NC X 3-1/2 LG	4, 8, 4, 8	4, 8, 4, 8
3.7	HEX HD BOLT, WASHER, LOCKWASHER, & HEX NUT	15A, 27	2	1/2 NC X 2-1/2 LG	6, 12, 12, 6	6, 12, 12, 6
3.8	WASHER	21	2	1/2 DIA	4	4
4	VACUUM BREAK VENT	19	2,3	PER 107040	1	1
5	DOOR PIVOT PIN	9A	2,3	3/4 DIA (REF); PER 107041	2	2
6	CENTERING WASHERS	13	2,3	.81 ID X 4.00 OD X 1/4 THK	8	8
7	SPACER WASHER	21	2,3	.78 ID X 4.00 X 1/8 THK	4	4
8	COLLAR	9A	2,3	PER 107043	2	2
9	WASHER	21	2	3/4 DIA (1 1/16 THK)	4	4
10	COTTER PIN	9B	2	1/8 DIA X 2-1/2 LG	2	2
11	HEX HEAD BOLT, WASHER, LOCKWASHER & NUT	15A, 27	2	1/2 NC X 1-1/4 LG	2ea	2ea
12	GASKET	13	2	1 INCH THK., 36-1/2 I.D./42-5/8 O.D.	1	1
20						
21						
22						
23	ISOLATION SLEEVE	35	2	.54 ID X .84 OD X 3/8 LG	16	16
24						
25						
26						
27						
28						
29						
30						
31						

This drawing is property of WATERMAN INDUSTRIES INC. Not to be used or reproduced without WATERMAN INDUSTRIES permission in writing. Items on this drawing are covered by patents. This equipment is of Nekton design - manufactured and sold under NEKTON INC.'s license.

REV.	DATE	BY
REV. #	DATE	BY
REV. #	DATE	BY
REV. #	DATE	BY
REV. #	DATE	BY
REV. #	DATE	BY
REV. #	DATE	BY

(1) GATE REQUIRED AT OUTFALL (1)

36" DIA WATERMAN - NEKTON SELF-REGULATING TIDEGATE

FOSTER WHEELER ENV. 10900 N.E. 8th ST., SUITE 1300 BELLEVUE, WA. 98004 P.O. NO. 018494

JOB NO. L-4551 DREW
 DRAWING NO. N099-H-2064A 1
 DRAWN BY CHECKED BY
 DR SH
 SCALE NONE DATE 6-4-99
 DRAWING NO. RC-99-0697 1 OF 2
 SHEET

RED TOP WATERMAN INDUSTRIES INC. EXETER, CALIFORNIA 93221

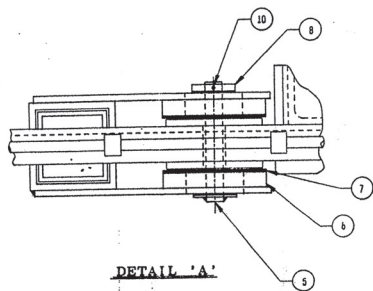

DETAIL 'A'

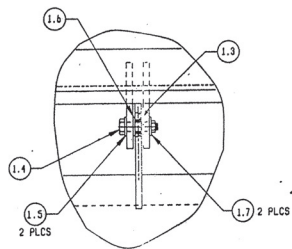

DETAIL 'E'

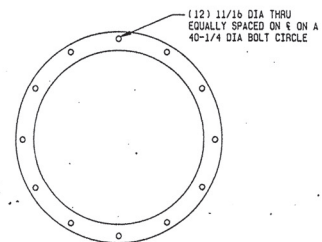
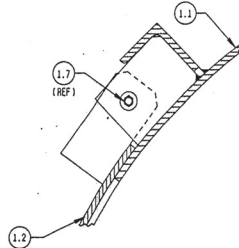

REAR FLANGE

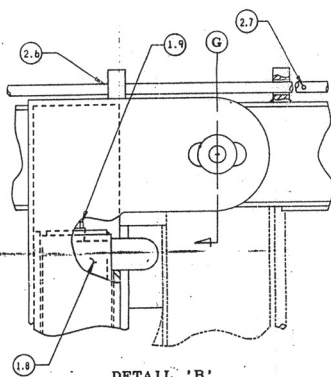

DETAIL 'B'

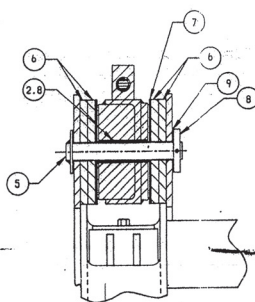

SECTION G

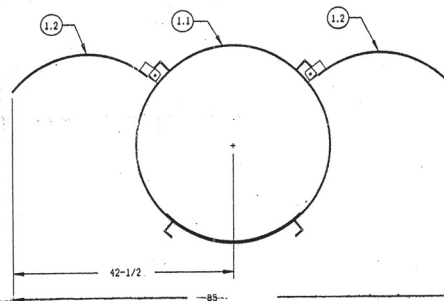

REQUIRED CLEARANCE DIMENSIONS

(COVER 1.2 FULL OPEN)

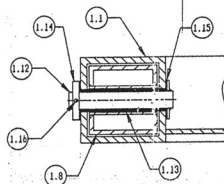

SECTION D

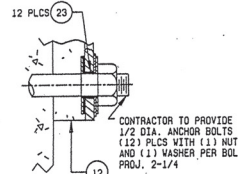

DETAIL 'H'

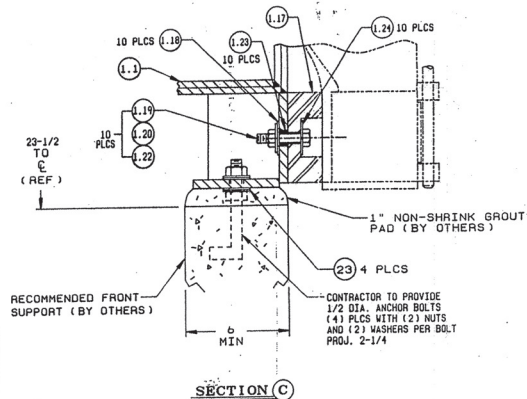

SECTION C

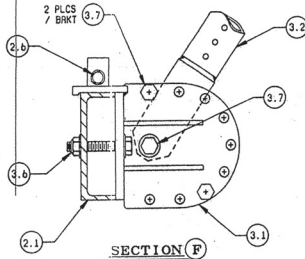

SECTION F

3. ALL ALUMINUM IN CONTACT W/ CONCRETE TO BE FIELD PAINTED ON INSTALLATION W/ BITUMASTIC PAINT. (BY OTHERS)
- 2 3/8 INCH SCH'L 40 PIPE.
- 1 CONTRACTOR TO VERIFY OR SUPPLY.
- NOTES: UNLESS OTHERWISE SPECIFIED.

This drawing is property of WATERMAN INDUSTRIES INC. Not to be used or reproduced without WATERMAN INDUSTRIES permission in writing. Ideas on this drawing are covered by patents. This equipment is of Nekton design - Manufactured and sold under NEKTON INC's license.		REV. # DATE BY REV. # DATE BY REV. # DATE BY REV. # DATE BY REV. # DATE BY
REF. NAVAL UNDERSEA WARFARE CENTER KEY PORT, WASHINGTON	FOR FOSTER WHEELER ENV. 10900 N.E. 8th ST., SUITE 1300 BELLEVUE, WA. 98004 P.O. NO. 018494	JOB NO. P.M. 1-4551 DREW QUOTE NO. ITEM # N099-H-2064A DRAWN BY CHECKED BY OR SH SCALE NONE DATE 8-4-99 DRAWING NO. SHEET RC-99-0697 2 OF 2
36 DIA WATERMAN - NEKTON SELF-REGULATING TIDEGATE		RED TOP WATERMAN INDUSTRIES INC. EXETER, CALIFORNIA 93221

APPENDIX E

**RESPONSES TO REGULATORY AGENCY COMMENTS ON DRAFT
FINAL OPERATION AND MAINTENANCE PLAN**

Scott Elkind

From: Craig, Harry <Craig.Harry@epa.gov>
Sent: Friday, October 26, 2018 2:34 PM
To: Alam, Mahbub (ECY); Cellucci, Carlotta CIV NAVFAC NW, EV31; Scott Elkind
Cc: dtaylor@suquamish.nsn.us; JoAnn Grady
Subject: RE: draft 2018 Keyport O&M plan comments

Carlotta,

I did not have any comments on the O&M plan.

Harry

From: Alam, Mahbub (ECY) [mailto:MALA461@ECY.WA.GOV]
Sent: Thursday, October 25, 2018 5:59 PM
To: Cellucci, Carlotta CIV NAVFAC NW, EV31 <carlotta.cellucci@navy.mil>; Scott.Elkind@sealaska.com
Cc: dtaylor@suquamish.nsn.us; Craig, Harry <Craig.Harry@epa.gov>; JoAnn Grady <joanngrady@gmail.com>
Subject: FW: draft 2018 Keyport O&M plan comments

Hi, Carlotta:

Ecology reviewed the O&M plan. We have no comments and agree with Denice that there are some repeat languages and overall organization could be improved.

Denice, I forwarded your comments email to Scott Elkind as I remember from last week's meeting that comments to O&M plan goes to Scott and comments to characterization report goes to Michael Meyer.

Sincerely,

Mahbub Alam, PhD, PE
Environmental Engineer
(360) 407-6913; mahbub.alam@ecy.wa.gov

From: Denice Taylor [mailto:dtaylor@suquamish.nsn.us]
Sent: Wednesday, October 24, 2018 4:23 PM
To: Cellucci, Carlotta CIV NAVFAC NW, EV31 (carlotta.cellucci@navy.mil) <carlotta.cellucci@navy.mil>
Cc: Alam, Mahbub (ECY) <MALA461@ECY.WA.GOV>; Harry Craig (Craig.Harry@epamail.epa.gov) <Craig.Harry@epamail.epa.gov>; JoAnn Grady (joanngrady@gmail.com) <joanngrady@gmail.com>; Meyer, Michael (meyerm@battelle.org) <meyerm@battelle.org>
Subject: draft 2018 Keyport O&M plan comments

Carlotta,

I have reviewed the draft 2018 O&M plan for Keyport. I agree with the scope of work to be performed, including plantation facilities maintenance, tide gate inspection and maintenance, OU 1 Area 1 well resurvey and OU 2 Area 8 well redevelopment.

However, I found Section 2 of the plan confusing and recommend reorganizing and revising the phytoremediation discussions to focus on the elements (tree health monitoring and plantation maintenance) of that remedy component that are to be addressed by this plan. It is recommended that Section 2 be reorganized as follows:

2.1 Keep as is

2.2 Phytoremediation Remedy

- keep the first 2 sentences as an intro

2.2.1 Move ROD Requirements here

2.2.2 Move Plantation Facilities here

2.2.3 Move Phytoremediation Monitoring Objectives here

- 2.2.3.1 Included description of previous monitoring and maintenance activities from pg 2-2 here

Repetitive sections and discussion of performance criteria should be deleted. I have also attached a copy of pages 2-1 to 2-7 with handwritten edits.

The Tribe previously agreed with the recommendation in the 2017 Annual O&M report that the remaining elements of the Keyport LTM be suspended until the characterization effort is complete, the CSM has been updated, and the MMA SAP has been updated. The draft 2018 O&M plan should reflect the current work to be performed.

Please contact me if you have any questions or would like me to review revisions to the plan.

Denice

360-394-8449 (office)

360-981-0102 (cell)

RESPONSES TO STAKEHOLDER COMMENTS

Draft Final Operation and Maintenance Plan, Operable Unites 1 and 2 Naval Base Kitsap, Kitsap Washington

Comments from Denice Taylor, Suquamish Tribe, October 24, 2018.

I have reviewed the draft 2018 O&M plan for Keyport. I agree with the scope of work to be performed, including plantation facilities maintenance, tide gate inspection and maintenance, OU 1 Area 1 well resurvey and OU 2 Area 8 well redevelopment.

However, I found Section 2 of the plan confusing and recommend reorganizing and revising the phytoremediation discussions to focus on the elements (tree health monitoring and plantation maintenance) of that remedy component that are to be addressed by this plan. It is recommended that Section 2 be reorganized as follows:

- 2.1 Keep as is
- 2.2 Phytoremediation Remedy - keep the first 2 sentences as an intro
 - 2.2.1 Move ROD Requirements here
 - 2.2.2 Move Plantation Facilities here
 - 2.2.3 Move Phytoremediation Monitoring Objectives here
 - 2.2.3.1 Included description of previous monitoring and maintenance activities from pg 2-2 here

Response: Section 2 has been reorganized as recommended.

Repetitive sections and discussion of performance criteria should be deleted. I have also attached a copy of pages 2-1 to 2-7 with handwritten edits.

Response: Section 2 has been revised as recommended.

The Tribe previously agreed with the recommendation in the 2017 Annual O&M report that the remaining elements of the Keyport LTM be suspended until the characterization effort is complete, the CSM has been updated, and the MMA SAP has been updated. The draft 2018 O&M plan should reflect the current work to be performed.

Response: The following text related to suspension of the OU 1 long-term monitoring program has been added to Section 2.2.3:

“Based on the recommendations of the 2017 O&M Report (Navy 2018a), LTM at OU 1 has been suspended until the results of the ongoing re-characterization of OU 1 have been completed and fully evaluated, the conceptual site model has been updated, and the Management and Monitoring Approach Sampling and Analysis Plan (Navy 2017e) has been revised to reflect the new understanding of groundwater conditions at OU 1.”

As needed, the plan text has been revised to reflect the actual activities to be performed in 2018 and early 2019.