



DEPARTMENT OF
ECOLOGY
State of Washington

Industrial Stormwater General Permit

Implementation Manual for Log Yards

Revised December 2016
Publication no. 04-10-031

Publication and Contact Information

This report is available on the Department of Ecology's website at <https://fortress.wa.gov/ecy/publications/SummaryPages/0410031.html>

For more information contact:

Water Quality Program
P.O. Box 47600
Olympia, WA 98504-7600
Phone: 360-407-6600

Washington State Department of Ecology - www.ecy.wa.gov

- Headquarters, Olympia 360-407-6000
- Northwest Regional Office, Bellevue 425-649-7000
- Southwest Regional Office, Olympia 360-407-6300
- Central Regional Office, Yakima 509-575-2490
- Eastern Regional Office, Spokane 509-329-3400

Accommodation Requests: To request ADA accommodation including materials in a format for the visually impaired, call Ecology at 360-407-6600. Persons with impaired hearing may call Washington Relay Service at 711. Persons with speech disability may call TTY at 877-833-6341.

Industrial Stormwater General Permit Implementation Manual for Log Yards

Water Quality Program
Washington State Department of Ecology
Water Quality Program

This page is purposely left blank

Table of Contents

Acknowledgements		iii
1. Background		1
Purpose.....		1
Required Industrial Stormwater General Permit Coverage based on Standard Industrial Classification (SIC).....		1
Pollutant Generating Sources.....		2
2. Choosing Best Management Practices		3
The ISGP Requirement for Choosing BMPs		3
Option 1 – The Presumptive Approach:		3
Option 2 – The Demonstration Approach:.....		3
BMP Selection Process and Implementation Schedule		4
Benchmark Values and Significant Amounts		4
3. Stormwater Pollution Prevention Plan (SWPPP)		5
SWPPP Contents:.....		5
4. Operational BMPs for All Areas of Log Yard Activity		6
Good Housekeeping.....		6
Preventive Maintenance.....		7
Spill Prevention and Cleanup.....		9
Employee Training.....		11
Visual Inspections		11
Reporting and Recordkeeping.....		13
5. Source-Specific BMPs		14
BMPs at High Activity Areas:		14
BMPs for Wood Waste Debris and Bark Piles (Figure 3)		15
BMPs for the prevention of Erosion and Stormwater Contamination from Material Storage Pile Areas.....		15
BMPs at Storage and Handling Areas of Other Solid and Hazardous Wastes		16
BMPs at Vehicle, Parts Washing, or Cleaning Areas.....		16
BMPs for Fueling at Dedicated Stations (BMP S409)		17
Additional BMP for Vehicles 10 feet in height or greater.....		18
BMPs for Mobile Fueling of Vehicles and Heavy Equipment (BMP S419).....		19
BMPs for Storage of Liquids in Permanent Aboveground Tanks (S428)		21
BMPs for Storage of Liquid, Food Waste, or Dangerous Waste Containers (BMP S427) (typically ≤ 55 gal).....		22
BMPs for Maintenance and Repair of Vehicles and Equipment (BMP S414).....		25

BMPs for Erosion and Sediment Control	26
BMPs for Soil Contaminated with Oil/grease and/or Toxics Such as Chemicals, Pesticides and Metals	27
BMPs for Surface Protection of Green dimension lumber treated by FIFRA-registered chemicals and/or other chemicals	27
BMP Considerations for Paving High Activity Rock/Soil Areas	28
Basic Summary Approach for Stormwater Collection and Conveyance	28
6. Treatment BMPs.....	29
7. Operation and Maintenance	29
Appendix A References	31
Appendix B Example Sign for Employees	32
Appendix C Glossary and Acronyms	33
Contacts.....	35

Acknowledgements

The 2004 version of this document was prepared with considerable assistance from a technical advisory committee. The document could not have been prepared without the hands-on experience of the industrial, local government, and Ecology representatives who served on this committee. Ecology wishes to thank the committee for its time and effort.

The advisory committee consisted of the following members:

Name	Affiliation
Susan Bauer	Port of Port Angeles
Dana DeLeon	City of Tacoma
Bob Dick	Northwest Forestry Association, Olympia
Phelps Freeborn	Ecology Central Regional Office
Ying Fu	Ecology Eastern Regional Office
Steve Harrison	Skookum Lumber Co.
Ken Johnson	Weyerhaeuser Company, Federal Way
Keith Johnson	Ecology Headquarters Office
Jason Kent	Columbia Vista Co.
Bob Penhale	Ecology Northwest Regional Office
Marilou Pivrotto	Ecology Southwest Regional Office

Ecology completed the 2016 Update through the efforts of the following Ecology employees:

Douglas C. Howie, HQ, Technical Lead	Bob Wright, NWRO
Jeff Killelea, HQ	Greg Stegman, NWRO
Dan Gariepy, HQ	John Diamant, SWRO
Ray Latham, CRO	Steve Eberl, SWRO
Ed Abbasi, NWRO	Mike Hepp, ERO
Micah Corey, HQ	

Where to Obtain Copies of this Guidance Manual

Either download from Ecology's stormwater web site at the following internet address: <https://fortress.wa.gov/ecy/publications/publications/0410031.pdf> or contact Ecology's Publications Office at PO Box 47600, Olympia, WA 98504-7600, (360) 407-7472.

Ecology Regional Office Telephone Numbers

Eastern Regional Office	(509) 329-3400
Central Regional Office	(509) 575-2490
Northwest Regional Office	(425) 649-7000
Southwest Regional Office	(360) 407-6300
Headquarters/Stormwater Unit	(360) 407-6000

This page intentionally left blank

1. Background

Purpose

The purpose of this manual is to provide guidance to operators and/or owners of log yards for complying with Ecology's Industrial Stormwater General Permit (ISGP) requirements. It will be useful if combined with a thorough understanding of the ISGP requirements. It has no independent regulatory authority and does not establish new regulatory requirements or standards. Recommended references are as follows. Additional references are included in Appendix A:

- *Industrial Stormwater General Permit*
(<http://www.ecy.wa.gov/programs/wq/stormwater/industrial/ISGPFinal2015.pdf>)
- *How to Do Stormwater Sampling; A Guide for Industrial Facilities*
(<https://fortress.wa.gov/ecy/publications/summarypages/0210071.html>)
- *ISGP Stormwater Pollution Prevention Plan Template*
(<http://www.ecy.wa.gov/programs/wq/stormwater/industrial/index.html> Lower right hand side of page)
- *Stormwater Management Manual for Western Washington*
(<http://www.ecy.wa.gov/programs/wq/stormwater/manual.html>)
- *Stormwater Management Manual for Eastern Washington*
(<http://www.ecy.wa.gov/programs/wq/stormwater/easternmanual/manual.html>)
- *WPPA Washington State Marine Terminal AKART and ISGP Corrective Action Guidance Manual*
(<http://www.ecy.wa.gov/programs/wq/stormwater/industrial/2014Dec.WAStateMarineTerminalCorrectiveActionGuideManual.WPPA.pdf>)
- Various jurisdictions have produced their own Stormwater Guidance Manual. These may be appropriate for use in specific jurisdictions instead of the Ecology Manuals

Required Industrial Stormwater General Permit Coverage based on Standard Industrial Classification (SIC)

The best management practices (BMPs) specified in this document apply to log yards at facilities for which permit coverage is required. Classifications for these facilities are:

- SIC 2411 – Logging (Industrial uses limited to rock crushing, gravel washing, log sorting, and log storage)
- SIC 2421 – Sawmills and Planning Mills, General
- SIC 2426 – Hardwood Dimension and Flooring Mills
- SIC 2429 – Special Product Sawmills, Not Elsewhere Classified
- SIC 2431 – Millwork
- SIC 2435 – Hardwood Veneer and Plywood
- SIC 2436 – Softwood Veneer and Plywood
- SIC 2439 – Structural Wood Members, Not Elsewhere Classified

- SIC 2499 – Wood Products, Not Elsewhere Classified
- SIC 2611 – Pulp Mills

Pollutant Generating Sources

Stormwater pollutant generating areas at log yards can include:

- Log storage
- Rollout
- Sorting
- Scaling and cutting
- Log and liquid loading and unloading
- Truck, rail, ship, stacker and loader access areas
- Debarker
- Bark bin and conveyor
- Bark, ash, sawdust, and wood debris piles and other solid wastes
- Log trucks, stackers, loaders, forklifts, and other equipment
- Maintenance shop and parking
- Cleaning of vehicles, parts, and equipment
- Storage and handling of hydraulic oils, lubricants, fuels, paints, liquid wastes, and other liquid materials
- Metal salvage areas
- Wood preservation and surface protection with chemicals
- Contaminated soil (Figures 1A, 1B)



Figure 1A - Bark Debris at Log Deck



Figure 1B - Trash and Ponding

Stormwater pollutants can include:

- Particulates generated by sawdust
 - Wood/bark debris
 - Log yard soil erosion, and dirt from logging trucks
 - Leachate from wood, bark, and ash wastes
 - Lead from discarded batteries
 - Wastewater and equipment/vehicle wash water spillage to storm drains
 - Pesticides used for weed, insect and fungal control
 - Leaks or spills of liquids such as fuels and hydraulic fluids
- Pollutant constituents include Chemical Oxygen Demand (COD), total suspended solids (TSS), turbidity, low/high pH, oil sheen, zinc, and copper.

2. Choosing Best Management Practices

The ISGP Requirement for Choosing BMPs

The ISGP requires the implementation of BMPs to comply with state water quality standards, state all known, available, and reasonable methods of treatment (AKART¹) requirements, and federal technology-based treatment requirements. Washington State adopted these standards and technology-based requirements. Permittees must demonstrate that their BMPs meet the standards and requirements described in the Washington State rules using one of the following options:

Option 1 – The Presumptive Approach:

Ecology presumes that project proponents who choose to follow the stormwater management approaches listed in Ecology-approved stormwater manuals have satisfied the requirement to document the technical basis for the design criteria used to design their stormwater management BMPs. Those proponents do not need to provide technical justification to support the selection of BMPs for their projects. Following the stormwater management practices in this and other Ecology-approved manuals means adhering to the guidance provided for proper selection, design, construction, implementation, operation, and maintenance of BMPs. This approach will generally be more cost effective for typical development and redevelopment projects.

Permittees who use the presumptive approach do not need to include within the Stormwater Pollution Prevention Plan (SWPPP) the technical basis, which supports the performance claims for the BMPs used.

Note that the BMPs included in the Stormwater Management Manual for Western Washington (SWMMWW) and Stormwater Management Manual for Eastern Washington (SWMMEW) were developed based on a percent removal of a given pollutant. Ecology based the requirements in the ISGP on the concentration of pollutants in stormwater discharged from the site. It is possible that the stormwater pollutant influent concentration is so high that removal of a given percentage of a pollutant will not provide a sufficiently low concentration in the effluent to meet the required benchmark concentration. The permittee is not relieved of the requirement strive to attain benchmark concentration goals by just using a BMP identified in an Ecology-approved Stormwater Management Manual. You may need to apply additional source control measures or additional BMPs if subsequent sampling shows you are exceeding the benchmark.

Option 2 – The Demonstration Approach:

Permittees must document the technical basis for the selection of all stormwater BMPs within the SWPPP. The SWPPP must document the selection of stormwater BMPs; the pollutant removal performance expected; the technical basis that support the performance claims for the selected BMPs; and an assessment of how the selected BMPs will comply with state water quality standards, the state AKART requirements, and the federal technology-based treatment requirements under 40 CFR part 125.3. Ecology expects the Permittee to base the demonstration documentation on good science and sound engineering. An example of an acceptable assessment protocol for technologies not in Ecology manuals is the Technology Assessment Protocol-

¹ AKART means “all known, available, and reasonable methods of prevention, control, and treatment.”

Ecology (TAPE) for emerging stormwater treatment technologies, which is available for download at <http://www.ecy.wa.gov/programs/wq/stormwater/newtech/>.

BMP Selection Process and Implementation Schedule

The first step in selecting BMPs is to identify pollutant sources and any existing BMPs. Then assess whether additional operational source control, structural source control, and erosion and sediment control BMPs are necessary, as specified in this guidance. If after applying additional BMPs the stormwater still contains pollutants greater than the benchmark value, it will trigger further corrective action levels that may require implementing additional BMPs, including treatment BMPs.

Benchmark Values and Significant Amounts

Ecology defines a significant amount of a pollutant as a pollutant that is amenable to AKART, or an amount that has the reasonable potential to cause or contribute to a violation of surface or groundwater quality standards or sediment management standards.

Ecology uses the benchmark values specified in the ISGP (see the following table) as permit thresholds, below which Ecology considers a pollutant as unlikely to cause a water quality violation, and above which it may. When pollutant concentrations exceed benchmarks, corrective action requirements take effect. Benchmark values are not water quality standards and are not numeric effluent limitations; there are indicator values.

The parameters listed in the table apply to all the Standard Industrial Classification (SIC) codes listed in Section 1. Consider actions needed to reduce pollutants below benchmark values and record those actions in the SWPPP. Use benchmark values as a guide for level of acceptable pollutant concentrations.

Parameter	Benchmark Value
Turbidity	25 NTU
pH	5 - 9 pH units
Chemical Oxygen Demand (COD)	120 mg/L
Total Suspended Solids (TSS)	100 mg/l
Total Zinc	117 µg/L
Total Copper*	14 µg/L Western WA 32 µg/L Eastern WA
Visible Oil Sheen	No Visible Sheen

3. Stormwater Pollution Prevention Plan (SWPPP)

All permittees under the ISGP shall develop and implement a SWPPP. The permittee shall keep the SWPPP on-site and update the document as required.

SWPPP Contents:

- A site map that shows:
 - The scale or include relative distances between significant structures and drainage systems.
 - Significant features.
 - The stormwater drainage and discharge structures and identify, by name, any other party other than the Permittee that owns any stormwater drainage or discharge structures.
 - The stormwater drainage areas for each stormwater discharge point off-site (including discharges to ground water) and assigns a unique identifying number for each discharge point.
 - Each sampling location by unique identifying number.
 - Paved areas and buildings.
 - Areas of pollutant contact (actual or potential) associated with specific industrial activities.
 - Conditionally approved non-stormwater discharges.
 - Surface water locations (including wetlands and drainage ditches).
 - Areas of existing and potential soil erosion (in a significant amount).
 - Vehicle maintenance areas.
 - Lands and waters adjacent to the site that may be helpful in identifying discharge points or drainage routes.
- A Facility Assessment that:
 - Describes facility activities and equipment that may contribute pollutants to stormwater.
 - Describes industrial activities conducted at the site.
 - Provides an inventory of materials stored on the site.
 - Describes BMPs used on the site and the procedures for implementing the BMPs. The description should provide any site operator with the knowledge for implementing and maintaining each BMP.
- Identified people responsible for SWPPP development, implementation, maintenance, and modification (Pollution Prevention Team).
- A schedule/frequency for completing each housekeeping BMP.

4. Operational BMPs for All Areas of Log Yard Activity

Implementing the following operational BMPs will meet the ISGP requirements:

Good Housekeeping

These are good housekeeping practices for cleanup or preventing the generation of pollutants. The ISGP lists the following good housekeeping Operational Source Control BMPs as being mandatory. The Permittee may omit individual BMPs if site conditions render the BMP unnecessary, infeasible, or the Permittee provides alternative or equally effective BMPs. The Permittee must clearly justify each BMP omission in the SWPPP.

- Vacuum paved surfaces with a vacuum sweeper (or a sweeper with a vacuum attachment) to remove accumulated pollutants a minimum of once per quarter. For log yards, quarterly sweeping is probably not adequate to provide adequate pollutant removal.
- Identify and control all on-site sources of dust to minimize stormwater contamination from the deposition of dust on areas exposed to precipitation.
- Inspect and maintain bag houses monthly to prevent the escape of dust from the system. Immediately remove any accumulated dust at the base of exterior bag houses.
- Keep all dumpsters under cover or fit with a lid that must remain closed when not in use.

Ecology recommends the following good housekeeping Operational Source Control BMPs.

- Manage the handling and storage of bark and other wood-waste materials consistent with good industry practices. Provide source controls to prevent stormwater from coming into contact with potential pollutants.
- Establish procedures and maintenance frequencies to clean up the bark, wood waste, and any other pollutant debris accumulations. Stormwater runoff could carry pollutants away and discharge them into surface waters. Cleanup procedures can include use of mobile vacuum sweepers, scrapers, brow logs, and/or scoops.
- Conduct maintenance and cleanup at the following frequencies:
 - Daily, or as needed to reduce stormwater pollutants below a significant amount, and where accessible, at log sorting, scaling, and rollout areas; rail, truck, ship, log loader and stacker access and high traffic areas; bark, log, and waste loading and unloading areas; trailer hoists; outside wood material bins and conveyors; and debarkers.
 - After every log deck turnover (i.e., before a load of logs is added to the log deck) at log decks and interbays, if weather and soil/log conditions allow. Conduct maintenance/clean-up as soon as possible after log deck turnover.
 - Annually for the entire log yard, before the rainy season begins.

- Regularly, as needed, remove accumulated oil from oil/water separators, boomed areas, and other oil removal or oil containment systems to ensure their intended operating efficiency.
- At least once per year, or more frequently based on the inspections, remove and properly dispose of debris and sludge from all conveyance, collection, and treatment BMP systems such as catch basins, settling/detention basins, and oil/water separators.
- Clean up all catch basins when the depth of the sediment accumulation is greater than 60-percent of the distance from the bottom of the catch basin to the invert of the lowest pipe into or out of the catch basin. In addition, Permittees must keep the debris surface at least 6 inches below the outlet pipe.
- Do not discharge unpermitted liquid wastes, process wastewater, or sewage to the ground, storm drains, or surface water. Eliminate all illicit non-stormwater discharges within 30 days of discovery, or obtain an NPDES Permit for such discharge.

Preventive Maintenance

These practices at a facility minimize or eliminate the contamination of stormwater. The ISGP lists the following preventative maintenance Operational Source Control BMPs as mandatory. The Permittee may omit individual BMPs if site conditions render the BMP unnecessary, infeasible, or the Permittee provides alternative or equally effective BMPs. The Permittee must clearly justify each BMP omission in the SWPPP.

- Clean catch basins when the depth of debris reaches 60 percent of the sump depth. In addition, the Permittee must keep the debris surface at least 6 inches below the outlet pipe.
- Maintain ponds, tanks/vaults, catch basins, swales, filters, oil/water separators, drains, and other stormwater drainage/treatment facilities in accordance with the Maintenance Standards set forth in the applicable Stormwater Management Manual (SWMM), other guidance documents, or manuals approved in accordance with S3.A.3.c, demonstrably equivalent BMPs per S3.A.3.d, or an O&M Manual submitted to Ecology in accordance with S8.D.
- Inspect all equipment and vehicles during monthly site inspections for leaking fluids such as oil, antifreeze, etc. Take leaking equipment and vehicles out of service or prevent leaks from spilling on the ground until repaired.
- Immediately clean up spills and leaks (e.g., using absorbents, vacuuming, etc.) to prevent the discharge of pollutants.

Ecology recommends the following preventative maintenance Operational Source Control BMPs.

- Inspect and properly maintain stormwater drainage and treatment systems, and log yard equipment and systems that could fail and result in contamination of stormwater.
- At rock and soil yard areas:
 - Repair and/or stabilize soft spots, ponding, wheel ruts, and erodible soil areas where the potential for stormwater contamination exists. Use rock replacement/addition or paving as needed to control pollutants. Give a high priority to high activity areas.

- Repair entire rock and soil yard, as needed, to ensure proper containment, collection, and conveyance of stormwater, and the stabilization of erodible soil.
- At paved yard areas:
 - Repair major cracks or any other damage as needed to prevent impairment of ground water.
 - Construct impervious areas subject to frequent spills/leaks of fuels or organic solvents with Portland cement concrete or equivalent. Permittees can use asphalt if it is treated or formulated to be resistant to spilled or leaked fluids on the paved area. Normal asphalt is incompatible with fuels and most solvents and oils.
- For log loaders and stackers, trucks, fork lifts, chain saws, and other yard equipment:
 - Follow manufacturer’s maintenance instructions, including a frequency-based maintenance checklist for all fluid containing components (particularly the hydraulic oil system hoses, pump, valves, O-rings, gaskets, fittings, and the engine fluids) to prevent leaks and spills.
 - Provide a shift maintenance checklist to the operators of the log stackers/loaders that includes checking for fluid leaks and levels and instrument readings for all hydraulic and power train fluids before and after starting the engine, and testing the high pressure hydraulic oil system before operating in the yard.
 - Use high quality hydraulic oil hoses and fittings with high working and bursting pressure capability such as four-ply spiral steel hoses or equivalent, in the log loaders and stackers and replace as needed to prevent hose breaks.
 - Consider a hydraulic oil indicator or alarm system for the log stackers and loaders that can sense a hydraulic oil pressure loss.
 - Replace log stacker/loader hydraulic oils over an impervious contained area. Use drip pans to collect leaks from mobile equipment and vehicles when they are not in operation. (Figure 2)
 - Park log stackers and loaders, trucks, and forklifts in designated areas where you maintain proper control of oil leaks/ spills.

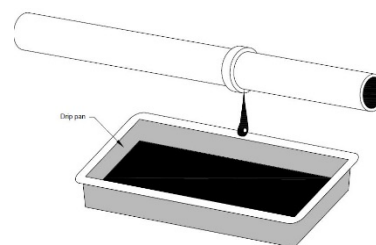

Figure 2: Use of drip pan for leaky equipment

- For the storage and handling of waste containers:
 - Place drums, buckets, and containers of fluids in a containment area with an impervious base or on secondary containment pallets.
 - Use appropriate containers for storing liquid wastes, such as steel or plastic drums that are rigid and durable, corrosion resistant, nonabsorbent, watertight, and equipped with a close fitting cover.
 - Use dumpsters, garbage cans, and comparable containers that are durable, corrosion resistant, nonabsorbent, nonleaking, and equipped with a solid cover for storing solid

wastes contaminated with liquids or other pollutant materials that can contaminate stormwater.

- For the control of weeds and other vegetation:
 - Consider alternative approaches to herbicides, such as covering, harvesting, substituting vegetative growth, and manual weed control. Use an herbicide as a last resort and select the herbicide that is the least toxic to humans and aquatic life.
 - Apply herbicides in accordance with label directions or use herbicide products applied by a licensed applicator.
 - Do not apply restricted herbicides within 100 feet of open waters including wetlands, ponds, streams, sloughs, and within close proximity of any drainage ditch or channel that leads to open water. Prior to spraying, visually mark all sensitive areas such as wells, creeks, and wetlands with appropriate signs/flags, so you do not conduct spraying within 100 feet of the sensitive area.
 - If required by label, permit, and/or the local government post public warnings indicating the area sprayed.
- For dust control sweep and/or apply water or materials that will not cause the pollution of ground water or surface water.
- Where practicable stencil warning signs at stormwater catch basins and drains, e.g., “Dump No Waste”.
- Post pollution prevention instructions for yard employees at log sort and access bay areas, vehicle/equipment maintenance areas, and any other potentially high pollution areas. (See example sign in Appendix B.)

Spill Prevention and Cleanup

The ISGP lists the following applicable spill prevention and cleanup Operational Source Control BMPs as being mandatory.

- Store all chemical liquids, fluids, and petroleum products on an impervious surface that is surrounded with a containment berm or dike that is capable of containing 10-percent of the total enclosed tank volume or 110-percent of the volume contained in the largest tank, whichever is greater. The Permittee may omit individual BMPs if site conditions render the BMP unnecessary, infeasible, or the Permittee provides alternative or equally effective BMPs. The Permittee must clearly justify each BMP omission in the SWPPP.
- Prevent precipitation from accumulating in containment areas with a roof or equivalent structure, or include a plan on how it will manage and dispose of accumulated water if a containment area cover is not practical.
- Locate spill kits within 25 feet of all stationary fueling stations, fuel transfer stations, and mobile fueling units. At a minimum, spill kits shall include:
 - Oil absorbents capable of absorbing 15 gallons of fuel.
 - A storm drain plug or cover kit.

- A non-water containment boom, a minimum of 10 feet in length with a 12 gallon absorbent capacity.
- A non-metallic shovel.
- Two five-gallon buckets with lids.
- Do not lock shut-off fueling nozzles in the open position. Do not “topoff” tanks while refueling.
- Block, plug, or cover storm drains that receive runoff from areas during fueling.
- Use drip pans or equivalent containment measures during all petroleum transfer operations.
- Locate materials, equipment, and activities so that leaks are contained in existing containment and diversion systems (confine the storage of leaky or leak-prone vehicles and equipment awaiting maintenance to protected areas).
- Use drip pans and absorbents under or around leaky vehicles and equipment, or store indoors where feasible. Drain fluids from equipment and vehicles prior to on-site storage or disposal.
- Maintain a spill log that includes the following information for chemical and petroleum spills: date, time, amount, location, and reason for spill; date/time clean-up completed, notifications made and staff involved.

Ecology recommends the following spill prevention and cleanup Operational Source Control BMPs.

- Prevention should be foremost, especially in vehicle/equipment fueling and maintenance areas.
- Identify areas where potential spills can contaminate stormwater.
- Stop, contain, and clean up all spills immediately upon discovery.
- Deploy a storm drain plug or cover kit over nearby drains.
- Collect oil-contaminated absorbent as a solid and place it in appropriate disposal containers. Do not flush absorbent material to a storm drain.
- Promptly report any spills or releases of materials, which may contaminate stormwater to the appropriate person or persons identified in the SWPPP. Notify Ecology and the local Sewer Authority immediately if the spill may reach sanitary or storm sewers, ground, or surface water. (Chapter 173-303-145 WAC and Ch. 90.48 RCW).
- In addition to Washington’s, spill control requirements also comply with the U.S. Environmental Protection Agency (EPA) Oil Spill Prevention Control and Countermeasure Plan (Section 311 of Clean Water Act) requirements which apply to aboveground storage facilities of 1,320 gallons or more.
- Place a small oil spill containment and cleanup kit on each hydraulic log stacker and log loader for immediate spill response and temporary control by the operator. Place these kits in chemically resistant containers or plastic bags, properly labeled, and readily accessible to the operator.

Employee Training

The ISGP lists the following employee training Operational Source Control BMPs.

The SWPPP must contain documentation of how you will conduct training. You must train all employees that work near a pollutant source, BMP, and stormwater conveyance areas, at least annually to understand:

- An overview of the SWPPP.
- How employees make a difference in complying with the SWPPP.
- Spill response procedures.
- Good housekeeping.
- Preventive Maintenance requirements.
- Environmentally acceptable material handling practices (bark, wood waste, log stacker/loader hydraulic oils, etc.) described in the SWPPP.

Maintain a log of dates on which specific employees received training.

Visual Inspections

The ISGP lists the following visual inspection Operational Source Control BMPs. At a minimum, the SWPPP must:

- Identify the qualified personnel who will conduct the inspections.
- Contain an inspection report or checklist that contains all items required by ISGP Condition S7 (Inspections)
- Provide a tracking procedure or follow-up procedure to ensure preparation of a report that lists any appropriate action taken in response to the inspection.
- Keep all completed inspection reports with the SWPPP.

Conduct and document all visual inspections at the facility **monthly**. Each inspection must include:

- Observations made at stormwater sampling locations and areas where stormwater associated with industrial activity is discharged off-site; or discharged to waters of the state (including groundwater), or to a storm sewer system that drains to waters of the state.
- Observation for the presence of floating materials, visible sheen, discoloration, turbidity, odor, etc., in the stormwater discharge(s).
- Observations for the presence of illicit discharges such as domestic wastewater, noncontact cooling water, or process wastewater (including leachate).
 - If the Permittee observes an illicit discharge, they must notify Ecology within 7-days
 - The Permittee must eliminate the illicit discharge within 30 days.

- A verification that the descriptions of potential pollutant sources required under the permit are accurate.
- A verification that the SWPPP reflects current conditions.
- An assessment of all implemented BMPs noting all of the following:
 - Effectiveness of BMPs inspected.
 - Locations of BMPs that need maintenance.
 - Reason maintenance is needed and a schedule for maintenance.
 - Locations where you need additional of different BMPs and the rationale for the additional or different BMPs.
- While in operation, inspect the yard daily for debris and leaks and spills of pollutant liquids at:
 - Log sort, scaling, and rollout yards.
 - Log deck and access bays.
 - Log stackers, loaders, and trucks.
 - Rail, and ship access areas.
 - Timber material bins.
 - Debarkers.
- Inspect weekly or as needed for rock and soil area soft spots, soil erosion, and proper grading and drainage at:
 - Log sort.
 - Scaling, and rollout yards.
 - Log deck and access bays.
 - Log loader.
 - Log stacker.
 - Truck, rail, and ship access areas.
- The Permittee must record the results of each inspection in an inspection report or checklist and keep the records on-site, as part of the SWPPP, for Ecology review. The Permittee must ensure each inspection report documents the observations, verifications, and assessments required in S7.B and the following:
 - Time and location of the inspection.
 - Locations inspected.
 - Statements that, in the judgement of 1) the person conducting the site inspection, and 2) the person described in Condition G2., the site is either in compliance or out of compliance with the terms and conditions of the SWPPP and the ISGP.

- A summary report and a schedule of implementation of the remedial actions that the Permittee plans to take if the site inspection indicates that the site is out of compliance. The remedial actions taken must meet the requirements of the SWPPP and the permit.
- Name, title, and signature of the person conducting site inspection, and the following statement: “I certify that this report is true, accurate, and complete, to the best of my knowledge and belief.”
- Certification and signature of the person described in Condition G2.A, or a duly authorized representative of the facility, in accordance with Conditions G2.B and D. Reports of Non-Compliance

The Permittee shall prepare reports of non-compliance identified during an inspection in accordance with the requirements of ISGP Condition S9.E.

Reporting and Recordkeeping

Include with the SWPPP the following records and reports as required by the ISGP:

- Annual Reports
- The Monitoring Plan for stormwater discharges at your facility
- Copies of notifications to Ecology regional offices of any noncompliance
- Quarterly sampling data, including field notes (date, location, time, weather, and name of the individual(s) conducting sampling), lab sheets showing analytical methods and results, and summaries of visual inspection reports with tracking procedures on action steps taken.
 - Report quarterly sampling results to Ecology Headquarters electronically using WQWebCMR (unless Ecology granted an electronic reporting waiver). To sign up electronically, follow the step-by-step registration instructions, with screen shots, provided at <http://www.ecy.wa.gov/programs/wq/permits/paris/webdmr.html>. Monitoring reports must include information on:
 - Analytical results
 - Absence of discharges at designated sampling points
 - When you did not conduct sampling due to consistent attainment of benchmark values
 - Include any stormwater pollutant monitoring data not required by the ISGP
 - Submit quarterly discharge monitoring reports (DMRs) no later than May 15, August 15, November 15, and February 15.
 - Keep laboratory analytical reports on-site and they must include:
 - Sampling date
 - Sample location
 - Date of analysis
 - Parameter name
 - Chemical Abstract Service number
 - Analytical method/number

- Method detection limit
- Lab Practical Quantitation Limit
- Reporting units
- Concentration detected
- Retain all DMRs, inspection reports, monitoring instrument calibration and maintenance, all permit application records of data, reports required by the ISGP, and all compliance records for a minimum of 5 years.

5. Source-Specific BMPs

Implementing the following Source-Specific BMPs for pollutant sources will help a Permittee meet the ISGP benchmarks:

BMPs at High Activity Areas

To prevent or reduce the erosion of soil and the generation of wood waste, bark debris, and contaminated stormwater:

- Pave the high activity area where practicable and reasonable to facilitate cleaning. Do not pave over soil known to be contaminated with pollutants unless it has been determined that ground water has not been, and will not be, contaminated by the soil or the work is otherwise approved in a MTCA or other “clean-up” plan.
- Slope all high activity paved and rock areas to minimize the erosion of soil and wood/bark materials, and the formation of contaminated stormwater. Minimize or eliminate ponding under piles, and contact between bark or wood materials and stormwater wherever practicable.
- Optimize stormwater segregation in high activity areas as follows:
 - Provide slopes sufficient to prevent run-on of uncontaminated stormwater into pollutant source areas.
 - Convey contaminated stormwater to appropriate pollution control system(s).
 - Apply curbing or berming where needed for segregation and use curb/berm materials that will not leach or erode.

BMPs for Wood Waste Debris and Bark Piles (Figure 3)

Implement BMPs for solid wastes that are stored in piles and not intended for recycling, pursuant to the most recent update of Chapter 173-304 WAC, or Chapter 173-350 WAC, Solid Waste Handling Standards as it applies. You should also contact the local jurisdictional health department on applicability and implementation issues.

WAC 173-350 does not apply to wood waste used for ornamental, animal bedding, mulch, and plant bedding, or road building purposes. Wood wastes designated for recycle under some conditions may also be exempt from the solid waste rule requirements. Recyclable wood wastes include beauty bark, compost destined for sale, hog fuel piles for use as fuel, or raw materials stored temporarily in piles actively used or recycled within the above time-periods and conditions.



Figure 3 Bark Pile on Paved Surface

BMPs for the prevention of Erosion and Stormwater Contamination from Material Storage Pile Areas

- If feasible, cover the piles (using roofs, buildings, canopies, silos, van trailers, sheds, tarps, etc.) to prevent contact with rainfall. (Figs. 4A and 4B)
- Pave the area, if practicable, to increase sweeping and cleaning effectiveness.
- Provide slopes, berms, and/or curbs sufficient to prevent run-on of uncontaminated stormwater and to convey contaminated stormwater to appropriate pollution control system(s).
- Limit sloping to prevent erosion of soil, bark, and woodwaste.
- Slope the material storage pile areas to prevent ponding under the piles and to convey stormwater to treatment. (see Section 6)
- Avoid contamination of the piles by oils, solvents, chemically treated wood, etc.
- Limit storage time, surface areas, and volumes of bark and woodwaste piles exposed to precipitation to minimize the generation of contaminated stormwater.

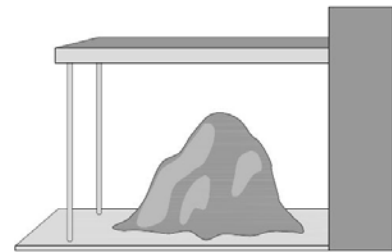

Figure 4A Covered Storage Area

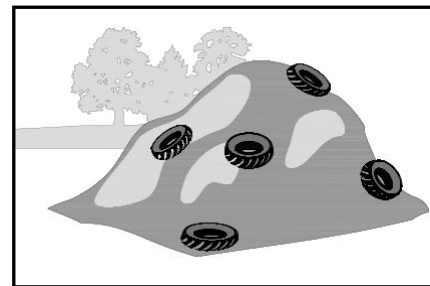

Figure 4B Pile Covered with Plastic Sheer

BMPs at Storage and Handling Areas of Other Solid and Hazardous Wastes

Dispose of all other solid wastes in accordance with Chapter 173-350 Solid Waste Handling Standards as it applies, and dispose of dangerous wastes in accordance with Chapter 173-303 WAC, Dangerous Waste Regulations.

BMPs at Vehicle, Parts Washing, or Cleaning Areas

Implement one of the following BMP options:

Preferred Option – Conduct the washing/cleaning in an enclosed building, or under a roof or canopy, with an impervious floor, such as concrete with no floor drainage to the outside other than connections to sanitary sewers or treatment facilities authorized by local jurisdiction and/or an appropriate Ecology permit.

Minimum Option – If you cannot implement the preferred option, you can install an uncovered Portland cement concrete pad that is impervious and contained (Figure 5). Implement the following additional BMPs for the two options:

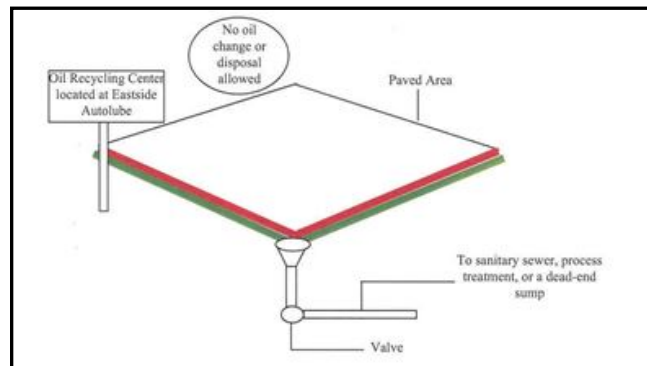

Figure 5. Sketch of a Wash Pad

- Design the pad to contain spills using one of the following methods: inward sloping berms or dikes around the perimeter, or a dead-end sump and/or a perimeter drain. Permittees can use the perimeter drain (trench, catchment drain) and/or the dead-end sump for collecting stormwater if the discharge outlet from the spill-collecting device has a locked valve that normally is in a closed position to prevent the release of pollutant fluids.
- Convey contaminated stormwater (commingled with wash water) collected on the pad to a sanitary sewer, if allowed by the local sewer authority after acceptable pretreatment. You may also convey contaminated stormwater to a total recycle system.
- Vehicle wash or rinse water may be discharged to:
 - A sanitary sewer (if allowed by the sewer authority).
 - Appropriate wastewater treatment.
 - Totally recycled (zero discharge).
- Any discharge to ground requires a high level of treatment and a State Waste Discharge Permit. Permittees must not discharge wash water to a storm drain that discharges to ground or to surface water.

BMPs for Fueling at Dedicated Stations (BMP S409)

Description of Pollutant Sources: A fueling station is a facility dedicated to the transfer of fuels from a stationary pumping station to mobile vehicles or equipment. It includes above or under-ground fuel storage facilities. In addition to general service gas stations, fueling may also occur at 24-hour convenience stores, construction sites, warehouses, car washes, manufacturing establishments, port facilities, and businesses with fleet vehicles. Typical causes of stormwater contamination at fueling stations include leaks/spills of fuels, lube oils, radiator coolants, and vehicle washwater.

Pollutant Control Approach: The facility must use a treatment BMP for contaminated stormwater and wastewaters in the fueling containment area.

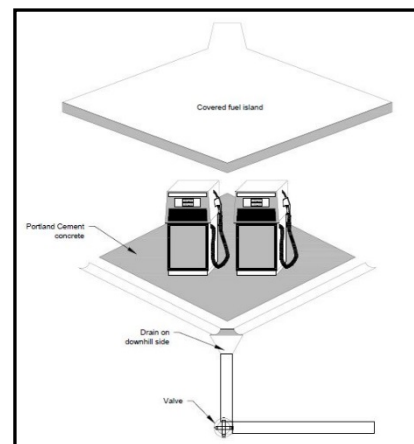

Figure 6

Applicable Operational BMPs:

- Prepare an emergency spill response and cleanup plan (per [S426 BMPs for Spills of Oil and Hazardous Substances](#)) and have designated trained person(s) available either on site or on call at all times to promptly and properly implement that plan and immediately cleanup all spills. Keep suitable cleanup materials, such as dry adsorbent materials, on site to allow prompt cleanup of a spill.
- Train employees on the proper use of fuel dispensers. Post signs in accordance with the Uniform Fire Code (UFC) or International Fire Code (IFC). Post “No Topping Off” signs (topping off gas tanks causes spillage and vents gas fumes to the air). Make sure that the automatic shutoff on the fuel nozzle is functioning properly.
- The person conducting the fuel transfer must be present at the fueling pump during fuel transfer, particularly at unattended or self-serve stations.
- Keep drained oil filters in a suitable container or drum.

Applicable Structural Source Control BMPs:

- Design the fueling island to control spills (dead-end sump or spill control separator in compliance with the UFC or IFC), and to treat collected stormwater and/or wastewater to required levels. Slope the concrete containment pad around the fueling island toward drains, either trench drains, catch basins, and/or a dead-end sump. The slope of the drains shall not be less than 1 percent (Section 7901.8 of the UFC, Section 5703.6.8 of the IFC).
- Drains to treatment facilities must have a normally closed shutoff valve. The spill control sump must be sized in compliance with Section 7901.8 of the UFC; or
- Design the fueling island as a spill containment pad with a sill or berm raised to a minimum of four inches (Section 7901.8 of the UFC) to prevent the runoff of spilled liquids and to prevent run-on of stormwater from the surrounding area. Raised sills are not required at the open-grate trenches that connect to an approved drainage-control system.
- The fueling pad must be paved with Portland cement concrete, or equivalent. Ecology does not consider asphalt an equivalent material.

- The fueling island must have a roof or canopy to prevent the direct entry of precipitation onto the spill containment pad (see Figure 6). The roof or canopy should cover the spill containment pad (within the grade break or fuel dispensing area) at a minimum, and preferably extending several additional feet to reduce the introduction of windblown rain. Convey all roof drains to storm drains outside the fueling containment area. When not feasible to install a roof or canopy for the large equipment (log stackers/loaders) an uncovered impervious contained pad is acceptable.
- Convey stormwater collected on the fuel island containment pad to a sanitary sewer system, if approved by the sanitary authority, or to an approved treatment system such as an oil/water separator and a basic treatment BMP. (Volume V of the SWMMWW lists basic treatment BMPs and includes media filters and biofilters). Discharges from treatment systems to storm drains or surface water or to the ground must not display ongoing or recurring visible sheen and must not contain oil and grease.
- Alternatively, collect stormwater from the fuel island containment pad and hold for proper off-site disposal.
- Approval from the local sewer authority is required for conveyance of any fuel-contaminated stormwater to a sanitary sewer. The discharged stormwater must comply with pretreatment regulations ([WAC 173-216-060](#)). These regulations prohibit discharges that could "cause fire or explosion." State and federal pretreatment regulations define an explosive or flammable mixture, based on a flash point determination of the mixture. You can convey stormwater to a sanitary sewer system if it is determined not to be explosive.
- Transfer the fuel from the delivery tank trucks to the fuel storage tank in impervious contained areas and ensure that appropriate overflow protection is used. Alternatively, cover nearby storm drains during the filling process and use drip pans under all hose connections.

Additional BMP for Vehicles 10 feet in height or greater

A roof or canopy may not be feasible at fueling stations that regularly fuel vehicles that are 10 feet in height or greater, particularly at industrial or WSDOT sites. At those types of fueling facilities, the following BMPs apply, as well as the applicable BMPs and fire prevention (UFC requirements) of this BMP for fueling stations:

- If a roof or canopy is impractical, the concrete fueling pad must be equipped with emergency spill control including a shutoff valve for drainage from the fueling area. Maintain the valve in the closed position in the event of a spill. An electronically actuated valve is preferred to minimize the time lapse between spill and containment. Clean up spills and dispose of materials off-site in accordance with [S406 BMPs for Spills of Oil and Hazardous Substances](#).
- The valve may be opened to convey contaminated stormwater to a sanitary sewer, if approved by the sewer authority, or to oil removal treatment such as an API or CP oil/water separator, catchbasin insert, or equivalent treatment, and then to a basic treatment BMP. Discharges from treatment systems to storm sewer or surface water or to the ground must not display ongoing or recurring visible sheen and must not contain greater than a significant amount of oil and grease.

BMPs for Mobile Fueling of Vehicles and Heavy Equipment (BMP S419)

Description of Pollutant Sources: Mobile fueling, also known as fleet fueling, wet fueling, or wet hosing, is the practice of filling fuel tanks of vehicles by tank trucks that are driven to the yards or sites where the vehicles to be fueled are located. Regulators categorize diesel fuel as a Class II Combustible Liquid, whereas they categorize gasoline as a Flammable Liquid.

Historically organizations conducted mobile fueling for off-road vehicles operated for extended periods in remote areas. This includes construction sites, logging operations, and farms. Some organizations conduct mobile fueling of on-road vehicles commercially in the state of Washington.

Pollutant Control Approach: Operators typically need proper training for the fueling operators, and the use of spill/drip control and reliable fuel transfer equipment with backup shutoff valving.

Applicable Operational BMPs:

Organizations and individuals conducting mobile fueling operations must implement the following bulleted BMPs. The operating procedures for the driver/operator should be simple, clear, effective, and their implementation verified by the organization liable for environmental and third party damage.

- Ensure that the local fire department approves all mobile fueling operations. Comply with local and Washington State fire codes.
- In fueling locations that are in close proximity to sensitive aquifers, designated wetlands, wetland buffers, or other waters of the state, approval by local jurisdictions is necessary to ensure compliance with additional local requirements.
- Ensure compliance with all 49 CFR 178 requirements for DOT 406 cargo tanker. Documentation from a Department of Transportation (DOT) Registered Inspector provides proof of compliance.
- Ensure the presence and the constant observation/monitoring of the driver/operator at the fuel transfer location at all times during fuel transfer and ensure implementation of the following procedures at the fuel transfer locations:
 - Locate the point of fueling at least 25 feet from the nearest storm sewer or inside an impervious containment with a volumetric holding capacity equal to or greater than 110 percent of the fueling tank volume, or covering the storm sewer to ensure no inflow of spilled or leaked fuel. Covers are not required for storm sewers that convey the inflow to a spill control separator approved by the local jurisdiction and the fire department. Potential spill/leak conveyance surfaces must be impervious and in good repair.
 - Place a drip pan or an absorbent pad under each fueling location prior to and during all dispensing operations. The pan (must be liquid tight) and the absorbent pad must have a capacity of at least 5 gallons. There is no need to report spills retained in the drip pan or the pad.

- Manage the handling and operation of fuel transfer hoses and nozzle, drip pan(s), and absorbent pads as needed to prevent spills/leaks of fuel from reaching the ground, storm sewer, and receiving waters.
- Avoid extending the fueling hoses across a traffic lane without fluorescent traffic cones, or equivalent devices, conspicuously placed to block all traffic from crossing the fuel hose.
- Remove the fill nozzle and cease filling the tank when the automatic shut-off valve engages. Do not lock automatic shutoff fueling nozzles in the open position.
- Do not “top off” the fuel receiving equipment.
- Provide the driver/operator of the fueling vehicle with:
 - Adequate flashlights or other mobile lighting to view fuel fill openings with poor accessibility. Consult with local fire department for additional lighting requirements.
 - Two-way communication with his/her home base.
- Train the driver/operator annually in spill prevention, cleanup measures, and emergency procedures. Make all employees aware of the significant liability associated with fuel spills.
- The responsible manager shall properly sign and date the fueling operating procedures. Distribute procedures to the operators, retain them in the organization files, and make them available in the event an authorized government agency requests a review.
- In the event of any spill of oil or other hazardous substance onto the ground or to surface or ground waters, you must call the following two numbers:
 - National Response Center: 1-800-424-8802, AND
 - Washington Emergency Management Division: 1-800-258-5990 –OR- 1-800-OILS-911

You must also call the Ecology regional office for the county where the spill is located:

- Southwest Regional Office – 1-360-407-6300
(Clallam, Clark, Cowlitz, Grays Harbor, Jefferson, Mason, Lewis, Pacific, Pierce, Skamania, Thurston, and Wahkiakum counties)
- Northwest Regional Office – 1-425-649-7000
(Island, King, Kitsap, San Juan, Skagit, Snohomish, and Whatcom counties)
- Central Regional Office – 1-509-575-2490
(Benton, Chelan, Douglas, Kittitas, Klickitat, Okanogan, and Yakima counties)
- Eastern Regional Office – 1-509-329-3400
(Adams, Asotin, Columbia, Ferry, Franklin, Garfield, Grant, Lincoln, Pend Oreille, Spokane, Stevens, Walla Walla, and Whitman counties)

- Establish a Spill “call down list” to ensure the rapid and proper notification of management and government officials. Keep the list in a protected but readily accessible location in the mobile fueling truck. The “call down list” should also pre-identify spill

response contractors available in the area to ensure the rapid removal of significant product spillage into the environment.

- Maintain a minimum of the following spill clean-up materials in all fueling vehicles, that are readily available for use:
 - Non-water absorbents capable of absorbing at least 15 gallons of diesel fuel.
 - A storm drain plug or cover kit.
 - A non-water absorbent containment boom of a minimum 10 feet in length with a 12-gallon minimum absorbent capacity.
 - A non-spark generating shovel (a steel shovel could generate a spark and cause an explosion in the right environment around a spill).
 - Two, five-gallon buckets with lids.
- Use automatic shutoff nozzles for dispensing the fuel. Replace automatic shut-off nozzles as recommended by the manufacturer.
- Maintain and replace equipment on fueling vehicles, particularly hoses and nozzles, at established intervals to prevent failures.

Applicable Structural Source Control BMPs:

Include the following fuel transfer site components:

- Automatic fuel transfer shut-off nozzles.
- An adequate lighting system at the filling point.

BMPs for Storage of Liquids in Permanent Aboveground Tanks (S428)

Description of Pollutant Sources: Aboveground tanks containing liquids (excluding uncontaminated water) may be equipped with a valved drain, vent, pump, and bottom hose connection. You may heat aboveground tanks with steam heat exchangers equipped with steam traps, if required. Leaks and spills can occur at connections and during liquid transfer. Oil and grease, organics, acids, alkalis, and heavy metals in tank water and condensate drainage can also cause stormwater contamination at storage tanks.

Pollutant Control Approach: Install secondary containment or a double-walled tank. Slope the containment area to a drain with a sump. Operators may need to discharge stormwater collected in the containment area to treatment such as an API or CP oil/water separator, or equivalent BMP. Add safeguards against accidental releases including protective guards around tanks to protect against vehicle or forklift damage, and tagging valves to reduce human error. Tank water and condensate discharges are process wastewater that may need an NPDES Permit.

Applicable Operational BMPs:

- Inspect the tank containment areas regularly for leaks/spills, cracks, corrosion, etc. to identify problem components such as fittings, pipe connections, and valves.
- Place adequately sized drip pans beneath all mounted taps and drip/spill locations during filling/unloading of tanks. Operators may need valved drain tubing in mounted drip pans.
- Vacuum sweep and clean the tank storage area regularly, if paved.
- Replace or repair tanks that are leaking, corroded, or otherwise deteriorating.
- All installations shall comply with the Uniform Fire Code and the National Electric Code.

Applicable Structural Source Control BMPs:

Locate permanent tanks in impervious (Portland cement concrete or equivalent) secondary containment surrounded by dikes as illustrated in Figure 7, or use UL Approved double-walled tanks. The dike must be of sufficient height to provide a containment volume of either 10 percent of the total enclosed tank volume or 110 percent of the volume contained in the largest tank, whichever is greater.

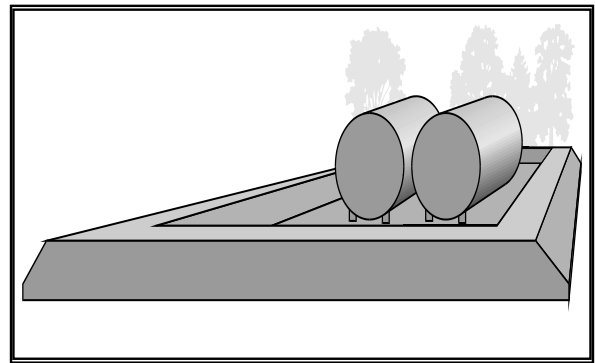

Figure 7 – Above-ground Tank Storage

- Slope the secondary containment to drain to a dead-end sump or equivalent, for the collection of small spills.
- Include a tank overflow protection system to minimize the risk of spillage during loading.

Applicable Treatment BMPs:

For an uncovered tank containment area, equip the outlet from the spill-containment sump with a normally closed shutoff valve. Operators may open this valve manually or automatically, only to convey contaminated stormwater to approved treatment or disposal, or to convey uncontaminated stormwater to a storm sewer. Evidence of contamination can include the presence of visible sheen, color, or turbidity in the runoff, or existing or historical operational problems at the facility. Use simple pH tests with litmus or pH paper for areas subject to acid or alkaline contamination.

At petroleum tank farms, convey stormwater contaminated with floating oil or debris in the contained area through an API or CP-type oil/water separator, or other approved treatment prior to discharge to storm drain or surface water.

BMPs for Storage of Liquid, Food Waste, or Dangerous Waste Containers (BMP S427) (typically ≤ 55 gal)

Description of Pollutant Sources: Steel and plastic drums with volumetric capacities of 55 gallons or less are typically used at industrial facilities for container storage of liquids and powders. The following BMPs apply to container(s) located outside a building.

Use these BMPs when temporarily storing accumulated:

- Food wastes
- Vegetable or animal grease
- Used oil
- Liquid feedstock
- Cleaning chemicals
- Other Dangerous Wastes (liquid or solid).

These BMPs do not apply when Ecology has permitted the business to store the wastes (Appendix IV-D R.4). Leaks and spills of pollutant materials during handling and storage are the primary sources of pollutants. Oil and grease, acid/alkali pH, BOD, COD are potential pollutant constituents.

Pollutant Control Approach: Store containers in impervious containment under a roof, or other appropriate cover, or in a building. When collection trucks directly pick up roll-containers, ensure a filet is on both sides of the curb to facilitate moving the dumpster. For storage areas on-site for less than 30 days, consider using a portable temporary secondary system like that shown in Figure 8 in lieu of a permanent system as described previously.

Applicable Operational BMPs:

- Place tight-fitting lids on all containers.
- Place drip pans beneath all mounted container taps and at all potential drip and spill locations during filling and unloading of containers.

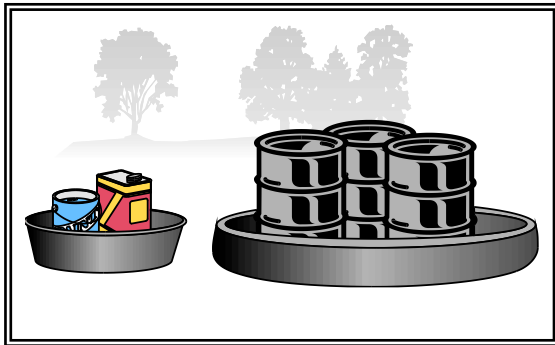

Figure 8 – Secondary Containment System

- Inspect container storage areas regularly for corrosion, structural failure, spills, leaks, overfills, and failure of piping systems. Check containers daily for leaks/spills. Replace containers, and replace and tighten bungs in drums as needed.
- Businesses accumulating Dangerous Wastes that do not contain free liquids need only to store these wastes in a sloped designated area with the containers elevated or otherwise protected from storm water run-on.
- Secure drums when stored in an area where unauthorized persons may gain access in a manner that prevents accidental spillage, pilferage, or any unauthorized use (see Figure 9).
- If the material is a Dangerous Waste, the business owner must comply with any additional Ecology requirements as specified in Appendix IV-D R.3.
- Storage of reactive, ignitable, or flammable liquids must comply with the Uniform Fire Code (Appendix IV-D R.2).
- Cover dumpsters, or keep them under cover such as a lean-to, to prevent the entry of stormwater. Replace or repair leaking garbage dumpsters.

- Drain dumpsters and/or dumpster pads to sanitary sewer. Keep dumpster lids closed.
- Install waterproof liners.

Applicable Structural Source Control BMPs:

- Keep containers with Dangerous Waste, food waste, or other potential pollutant liquids inside a building unless this is not feasible due to site constraints or Uniform/International Fire Code requirements.
- Store containers in a designated area, which is covered, bermed or diked, paved and impervious in order to contain leaks and spills (see Figure 10). Slope the secondary containment to drain into a dead-end sump for the collection of leaks and small spills.

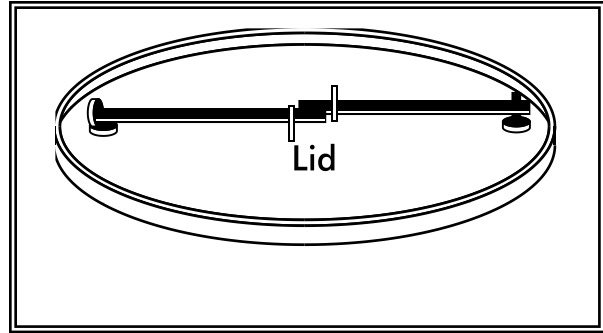

Figure 9 – Locking System for Drum lid

- For liquid wastes, surround the containers with a dike as illustrated in Figure 10. The dike must be of sufficient height to provide a volume of either 10 percent of the total enclosed container volume or 110 percent of the volume contained in the largest container, whichever is greater.
- Where material is temporarily stored in drums, use a containment system as illustrated, in lieu of the system in Figure 10 (see Figure 8).
- Place containers mounted for direct removal of a liquid chemical for use by employees inside a containment area as described previously. Use a drip pan during liquid transfer (see Figure 11).

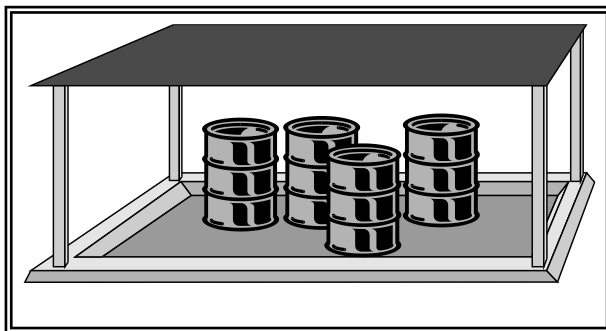

Figure 10 – Covered and Bermed Containment

Applicable Treatment BMP:

- For contaminated stormwater in the containment area, connect the sump outlet to a sanitary sewer, if approved by the local Sewer Authority, or to appropriate treatment such as an API or CP oil/water separator, catch basin filter or other appropriate system (see SWMMWW Volume V). Equip the sump outlet with a normally closed valve to prevent the release of spilled or leaked liquids, especially flammables (compliance with Fire Codes), and dangerous liquids. Open this valve only for the conveyance of contaminated stormwater to treatment.
- Another option for discharge of contaminated stormwater is to pump it from a dead-end sump or catchment to a tank truck or other appropriate vehicle for off-site treatment and/or disposal.

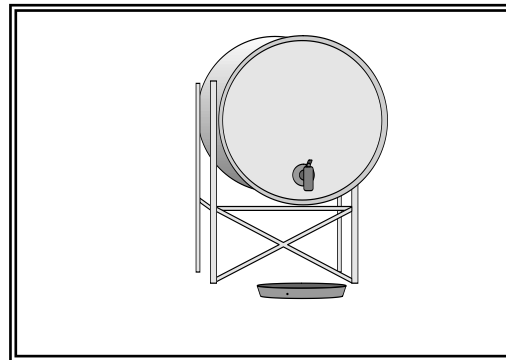

Figure 11 – Mounted Container - with drip pan (note that this figure does not show secondary containment)

BMPs for Maintenance and Repair of Vehicles and Equipment (BMP S414)

Description of Pollutant Sources: Pollutant sources include parts/vehicle cleaning, spills/leaks of fuel and other liquids, replacement of liquids, outdoor storage of batteries/liquids/parts, and vehicle parking.

Pollutant Control Approach: Control of leaks and spills of fluids using good housekeeping and cover and containment BMPs.

Applicable Operational BMPs:

- Inspect all incoming vehicles, parts, and equipment stored temporarily outside for leaks.
- Use drip pans or containers under parts or vehicles that drip or that are likely to drip liquids, such as during dismantling of liquid containing parts or removal or transfer of liquids.
- Remove batteries and liquids from vehicles and equipment in designated areas designed to prevent stormwater contamination. Store cracked batteries in a covered non-leaking secondary containment system.
- Remove liquids from vehicles retired for scrap.
- Empty oil and fuel filters before disposal. Provide for proper disposal of waste oil and fuel.
- Do not pour/convey washwater, liquid waste, or other pollutants into storm drains or to surface water. Check with the local sanitary sewer authority for approval to convey water to a sanitary sewer.

- Do not connect maintenance and repair shop floor drains to storm drains or to surface water.
- To allow for snowmelt during the winter, install a drainage trench with a sump for particulate collection. Use the drainage trench for draining the snowmelt only and not for discharging any vehicular or shop pollutants.

Applicable Structural Source Control BMPs:

- Conduct all maintenance and repair of vehicles and equipment in a building or other covered impervious containment area that is sloped to prevent run-on of uncontaminated stormwater and runoff of contaminated water.
- Operators may conduct maintenance of refrigeration engines in refrigerated trailers in the parking area. Exercise due caution to avoid the release of engine or refrigeration fluids to storm drains or surface water.
- Park large mobile equipment, such as log stackers, in a designated contained area.

Applicable Treatment BMPs:

- Convey contaminated stormwater runoff from vehicle staging and maintenance areas to a sanitary sewer, if allowed by the local sewer authority, or to an API or CP oil and water separator followed by a basic treatment BMP, applicable filter, or other equivalent oil treatment system.

Recommended Additional Operational BMPs:

- Store damaged vehicles inside a building or other covered containment, until successfully removing all liquids.
- Clean parts with aqueous detergent-based solutions or non-chlorinated solvents such as kerosene or high flash mineral spirits, and/or use wire brushing or sand blasting in a booth whenever practicable. Avoid using toxic liquid cleaners such as methylene chloride, 1,1,1-trichloroethane, trichloroethylene or similar chlorinated solvents. Choose cleaning agents that can be recycled.
- Inspect all BMPs regularly, particularly after a significant storm. Identify and correct deficiencies to ensure that the BMPs are functioning as intended.
- Avoid hosing down work areas. Use dry methods for cleaning leaked fluids.
- Recycle greases, used oil, oil filters, antifreeze, cleaning solutions, automotive batteries, hydraulic fluids, transmission fluids, and engine oils.
- Do not mix dissimilar or incompatible waste liquids stored for recycling.

BMPs for Erosion and Sediment Control

The SWPPP shall include BMPs necessary to prevent the erosion of soils and other earthen materials (crushed rock/gravel, etc.), control off-site sedimentation, and prevent violations of water quality standards. The Permittee shall implement and maintain:

- Sediment control BMPs such as detention or retention ponds or traps, vegetated filter strips, bioswales, or other permanent sediment control BMPs to minimize sediment loads in stormwater discharges.
- Filtration BMPs to remove solids from catch basins, sumps, or other stormwater collection and conveyance system components (catch basin filter inserts, filter socks, modular canisters, sand filtration, centrifugal separators, etc.).
- Volume II of the SWMMWW and Chapter 7 of the SWMMEW have information on many BMPs that you can use to provide Erosion and Sediment Control on your site.

BMPs for Soil Contaminated with Oil/grease and/or Toxics Such as Chemicals, Pesticides and Metals

If you discover soil contaminated with toxics, contact the local registered landfill in your area for assistance on acceptable disposal criteria. Implement the following BMP options, where applicable, if there is no actual or potential for the pollution of surface water or ground water by the contaminated soil.

Option 1 (Preferred) – Soil Remediation. Collect the contaminated soil in appropriate containers and transfer it to a covered impervious containment area on-site for temporary storage or remediation, if feasible, or arrange to transport it to a permitted waste treatment or disposal facility.

Option 2 – Prevent Contact with Stormwater. Cover the contaminated soil with a durable plastic cover, or equivalent, to prevent contact with stormwater and divert stormwater around the covered contaminated soil to prevent the contamination of stormwater.

Option 3 – Collect and Treat the Stormwater. Collect and treat the stormwater runoff from the contaminated soil site (see Section 6: Treatment BMPs) if the runoff contains greater than a benchmark value of any pollutant.

Additional BMP for all above options – Assess the potential for groundwater contamination. Contact your Ecology regional office for assistance if needed.

BMPs for Surface Protection of Green dimension lumber treated by FIFRA-registered chemicals and/or other chemicals

Logs and cut lumber dipped or sprayed with chemicals to control sap stain, mold, mildew, and insects, need containment during storage, handling, and use.

Log treating operations or storage areas shall not result in the release of any residual log treatment chemicals, which would cause the violation of ground water or surface water quality or sediment management standards. The goal is no discharge of any chemical. If you contaminate stormwater with any residual chemical after implementing the following BMPs, further controls are necessary. If this occurs, contact the Water Quality Program at your Ecology regional office for advice.

Implement the following BMPs:

- Apply log-treating chemicals on impervious containment such as Portland cement concrete or equivalent, in a building, or under a roof, cover, or equivalent structure.
- Store freshly treated logs on impervious containment in a building or under a roof, or equivalent cover, so there is no release of log treating chemicals, which would contaminate stormwater during outside storage or handling. Wrapping may also be used.
- Do not connect floor drains from the spray or dip facility to storm drains or to surface water.
- Dedicate equipment for log treatments, to avoid spreading the chemicals to other areas on the site.
- Store and handle all pesticides, chemicals and all equipment, containers, solid waste, and/or liquid wastes that is/are contaminated with log treatment chemicals in accordance with label instructions and Ecology's dangerous waste requirements (Chapter 173-303 WAC).
- If you identify soil contaminated with log treatment chemicals from past or current practices, call the regional office of Ecology's Toxics Cleanup Program for technical assistance.
- Do not vent volatile or mist-laden exhaust containing log treatment chemicals to the outside, unless necessary for occupational health and safety reasons.
- Clean up all spills and leaks immediately with dry absorbents and dispose in accordance with label instructions and Washington dangerous waste requirements.

BMP Considerations for Paving High Activity Rock/Soil Areas

Environmental benefits of paving the existing high activity rock/soil areas can include more efficient cleaning of debris and oil drips and less erosion of particulates from rock/soil work areas. Process improvements can include cleaner bark and hog fuel, less equipment, decreased saw and log stacker wear, and more efficient log stacker/loader operation. Permittees can efficiently collect and reuse water sprays required for maintenance of the quality of logs.

Basic Summary Approach for Stormwater Collection and Conveyance

Implement the following BMPs at the high activity areas, where applicable:

- Keep uncontaminated stormwater away from pollutant sources such as the high activity log and wood debris handling and storage areas, vehicle and equipment maintenance, bark and wood residue storage, and liquid storage areas.
- Collect, segregate, and convey to appropriate treatment BMPs, stormwater which contains greater than a benchmark value of a pollutant.
- Provide proper sloping and/or pavement to reduce or prevent ponding, erosion, and contamination of stormwater.
- Minimize the use of catch basins in the interior of the high activity areas, as they tend to fill rapidly with wood waste/sediment. The area should be sloped to drain stormwater to the perimeter where you can collect and treat it in larger solids handling systems.

6. Treatment BMPs

Design, construct, and operate treatment BMPs in accordance with the criteria in Ecology's applicable stormwater manual or documentation in the SWPPP. Ensure that the BMPs selected are demonstrably² equivalent to practices contained in stormwater technical manuals approved by Ecology, including the proper selection, implementation, and maintenance of all applicable and appropriate best management practices for on-site pollution control See ISGP Condition S3.A.3.

Employ oil/water separators, booms, skimmers, or other methods to eliminate or minimize oil and grease contamination of stormwater discharges.

Obtain Ecology approval before beginning construction/installation of all treatment BMPs that include the addition of polymers or other chemicals to provide treatment.

If Treatment BMPs are required to comply with ISGP Level 3 Corrective Action requirements, you must comply with the engineering report and treatment BMP construction /installation requirements in Condition S8.D.

7. Operation and Maintenance

Properly operate and maintain all stormwater treatment and control facilities and laboratories installed or used for compliance with the ISWGP. Ecology's stormwater manuals contain descriptions of Operation and Maintenance procedures for individual BMPs. (See references 4 and 5)

² Demonstrably Equivalent means that the applicant documented the technical basis for the selection of all stormwater best management practices within a SWPPP. The SWPPP must document 1) The method and reasons for choosing the stormwater best management practices selected; 2) The pollutant removal performance expected from the practices selected; 3) The technical basis supporting the performance claims for the practices selected, including any available existing data concerning field performance of the practices selected; 4) An assessment of how the selected practices will comply with state water quality standards; and 5) An assessment of how the selected practices will satisfy both applicable federal technology-based treatment requirements and state requirements to use all known, available, and reasonable methods of prevention, control, and treatment (AKART).

This page intentionally left blank

Appendix A

References

1. *Industrial Stormwater General Permit*
(<http://www.ecy.wa.gov/programs/wq/stormwater/industrial/index.html>)
2. *How to Do Stormwater Sampling; A guide for industrial facilities*
(<https://fortress.wa.gov/ecy/publications/summarypages/0210071.html>)
3. *Guidance Manual for Preparing/updating a Stormwater Pollution Prevention Plan for Industrial Facilities* (<https://fortress.wa.gov/ecy/publications/summarypages/0410030.html>)
4. *ISGP Stormwater Pollution Prevention Plan Template*
(<http://www.ecy.wa.gov/programs/wq/stormwater/industrial/index.html> Lower right hand side of page)
5. *Stormwater Management Manual for Western Washington*
(<http://www.ecy.wa.gov/programs/wq/stormwater/manual.html>)
6. *Stormwater Management Manual for Eastern Washington*
(<http://www.ecy.wa.gov/programs/wq/stormwater/easternmanual/manual.html>)
7. *Vehicle and Equipment Washwater, Best Management Practices Manual (Publication No. 95-056)* WA Dept. of Ecology, March 2012.
(<https://fortress.wa.gov/ecy/publications/summarypages/95056.html>)
8. *Code of Federal Regulations, Protection of the Environment, Title 40, Part 136, as updated.*
9. *Standard Methods for the Examination of Water and Wastewater*, APHA, latest edition.
10. *Requirements for Generators of Dangerous Wastes, Ecology, Chapter 173-303 WAC*
11. *Step-by-Step: Fact Sheets for Hazardous Waste Generators*, (Publication No. 91-12) Dept. of Ecology, January 2008.
12. *Minimum Functional Standards for Solid Waste Handling*, Ecology, WAC Chapter 173-304.
13. *Minimum Functional Standards for Containers*, WAC 173-304-200.
14. *Coast Guard Requirements for Marine Transfer of Petroleum Products*, 33 CFR Parts 153, 154 and 155.
15. *Submission of Plans and Reports for the Construction of Wastewater Treatment Plants*, WAC 173-240 (<https://fortress.wa.gov/ecy/publications/documents/173240.pdf>)
16. *USEPA/Ecology Emergency Spill Cleanup Regulations*, SPCC: 40 CFR Part 112 and WAC 173-303-350.

Appendix B Example Sign for Employees

Notice to all Employees

To minimize or prevent stormwater pollution

1. Do not dump any polluting fluid or any other pollutant down any storm drains.
2. Keep all paved areas clean of debris that could contaminate stormwater.
3. Prevent outside spills and leaks of liquids particularly during operation of log stackers and loaders.
4. Use oil containment booms to contain and dry absorbents to clean up spills and leaks of pollutant liquids immediately.
5. Notify management of:
 - Any outside leak, spill, or situation that can cause contamination of stormwater.
 - Ongoing or frequently recurring oil sheen on the surface of a stormwater discharge or in receiving water.
 - Any unsatisfactory stormwater pollution control system operation.

Appendix C

Glossary and Acronyms

AKART: All known, available, and reasonable methods of prevention, control, and treatment: It shall represent the most current methodology that can be reasonable, required for preventing, controlling, or abating the pollutants associated with a stormwater discharge.

APHA: American Public Health Association.

BMP: Best management practices: Schedules of activities, prohibitions of practices, maintenance procedures, and structural and/or managerial practices that when used singly or in combination, prevent or reduce the release of pollutants and other adverse impacts to waters of Washington State.

CFR: Code of Federal Regulations.

Dike/berm: A constructed barrier of compacted earth, rock, or gravel. In a stormwater facility, a berm may serve as a vertical divider typically built up from the bottom. A physical containment barrier, usually concrete, or earthen with impervious plastic liner for the containment of fluids.

DMR: Discharge monitoring report.

High activity areas: include routine operation of log stackers and loaders, forklifts, and trucks; liquid, log, bark, wood, wood waste and debris storage, handling and access; log truck, stacker and loader access; fueling, washing and maintenance; timber material storage bin and conveyance; and debarkers.

Leachate: Water or other liquid that has percolated through raw material, product, or waste and contains substances in solution or suspension as a result of the contact with these materials.

Log Yard: The total land area where logs are stored, transferred, shipped, received, sorted, debarked, or otherwise handled. It includes supporting industrial activities such as: equipment/vehicle use, maintenance/fueling/washing, liquid/solid material storage, material shipping/receiving, and bark/ash/wood debris storage and handling. It also includes all the stormwater drainage features and areas from these log yard activities.

NPDES: National Pollutant Discharge Elimination System: The national program for issuing, modifying, revoking, terminating, monitoring, and enforcing permits for discharges to surface water.

Oil: Includes gasoline, crude oil, fuel oil, diesel oil, lubricating oil, oily refuse and sludge, liquid natural gas, propane, butane, oils distilled from coal, and other liquid hydrocarbons regardless of specific gravity, or any petroleum related product. (Chapter 90.48 RCW)

Operational BMPs: Schedule of activities, prohibition of practices, maintenance procedures, employee training, good housekeeping, and other managerial practices to prevent or reduce the contamination of stormwater.

Pollutant: Solid waste, including wood and bark waste, incinerator residue, garbage; oil leaks; filter backwash; sewage; sewage sludge; chemical wastes; biological materials; and industrial, municipal, and agricultural waste; discharged into water, or any other material that can cause pollution of water.

Pollution: Contamination or other alteration of the physical, chemical, or biological properties of waters of the state of Washington. This includes changes in temperature, taste, color, turbidity, or

odor of the waters. It also includes discharge of any liquid, solid, gaseous, radioactive, or other substance into any waters of the state that will or is likely to create a nuisance or render such waters harmful, detrimental, or injurious to the public health, safety, or welfare. Discharges that may damage domestic, commercial, industrial, agricultural, recreational, or other legitimate beneficial uses; or cause damage to livestock, wild animals, birds, fish or other aquatic life.

Putrescible: Solid waste that contains material capable of decomposition by microorganisms.

RCW: Revised Code of Washington

Significant Amount: An amount of pollutant in a discharge that is amenable to AKART, or an amount of pollutant that has a reasonable potential to cause a violation of surface or groundwater quality standards or sediment management standards

Structural Source Control BMPs: Physical, structural, mechanical devices, or facilities that are designed to prevent pollutants from entering stormwater.

Stormwater Runoff: Water originating from rainfall or snowmelt found in drainage or conveyance facilities at industrial sites.

SWMMEW: Stormwater Management Manual for Eastern Washington: The technical manual revised by Ecology in 2004 that contains BMPs to prevent, control, or treat stormwater pollutants.

SWMMWW: Stormwater Management Manual for Western Washington: The technical manual revised by Ecology in 2014 that contains BMPs to prevent, control, or treat stormwater pollutants.

SWPPP: Stormwater Pollution Prevention Plan: A documented plan to implement measures to identify, prevent, and control the contamination of stormwater and its discharge to ground or surface water.

TMDL Plan: A total maximum daily load plan is a description of the type, amount, and sources of water pollution in a water body with strategies to control the pollution.

Treatment BMPs: Structural BMPs intended to remove pollutants from stormwater, such as oil/water separation, biofiltration, and sand filters. Permittees may also consider emerging technologies such as media filtration and manufactured water treatment technologies.

USEPA: U. S. Environmental Protection Agency

WAC: Washington Administrative Code

Water Quality Standards: State of Washington water quality standards for surface waters of the state, which are codified in Chapter 173-201 WAC.

Waters of the State: Waters within the geographic boundaries of the State of Washington, including lakes, rivers, ponds, streams, inland waters, underground waters, salt waters, and all other surface waters or watercourses.

Contacts

If you have questions or want more information, please contact Douglas C. Howie, P.E. at Ecology Headquarters office in Lacey at 360-407-6444 or douglas.howie@ecy.wa.gov.