

DEPARTMENT OF  
**ECOLOGY**  
State of Washington

## **Standard Operating Procedure EAP056, Version 1.3**

---

# **Measuring and Calculating Stream Discharge**

March 2018

Publication No. 18-03-203

## Publication information

This Standard Operating Procedure (SOP) is available on the Washington State Department of Ecology's website at <https://fortress.wa.gov/ecy/publications/SummaryPages/1803203.html>.

The Activity Tracker Code for this document is 12-076.

## Contact information

For more information contact:

Publications Coordinator  
Environmental Assessment Program  
P.O. Box 47600, Olympia, WA 98504-7600  
Phone: (360) 407-6764

Washington State Department of Ecology - [ecology.wa.gov](http://ecology.wa.gov)

- Headquarters, Olympia (360) 407-6000
- Northwest Regional Office, Bellevue (425) 649-7000
- Southwest Regional Office, Olympia (360) 407-6300
- Central Regional Office, Union Gap (509) 575-2490
- Eastern Regional Office, Spokane (509) 329-3400

## Purpose of this document

The Department of Ecology develops Standard Operating Procedures (SOPs) to document agency practices related to sampling, field and laboratory analysis, and other aspects of the agency's technical operations.

*Any use of product or firm names in this publication is for descriptive purposes only and does not imply endorsement by the author or the Department of Ecology.*

*Accommodation Requests: To request ADA accommodation including materials in a format for the visually impaired, call Ecology at 360-407-6764. Persons with impaired hearing may call Washington Relay Service at 711. Persons with speech disability may call TTY at 877-833-6341.*

Washington State Department of Ecology

Environmental Assessment Program

Standard Operating Procedure for Measuring and Calculating Stream Discharge

Version 1.3

Author – James R. Shedd

Date – December 2017

Reviewer – Tyler Burks

Date – December 2017

QA Approval - William R. Kammin, Ecology Quality Assurance Officer

Date – December 2017

EAP056

INITIALLY APPROVED: December 8, 2014

RECERTIFIED: December 8, 2017

Signatures on File

*Please note that the Washington State Department of Ecology's Standard Operating Procedures (SOPs) are adapted from published methods, or developed by in-house technical and administrative experts. Their primary purpose is for internal Ecology use, although sampling and administrative SOPs may have a wider utility. Our SOPs do not supplant official published methods. Distribution of these SOPs does not constitute an endorsement of a particular procedure or method.*

*Any reference to specific equipment, manufacturer, or supplies is for descriptive purposes only and does not constitute an endorsement of a particular product or service by the author or by the Department of Ecology.*

*Although Ecology follows the SOP in most instances, there may be instances in which Ecology uses an alternative methodology, procedure, or process.*

## SOP Revision History

Revision Date	Rev number	Summary of changes	Sections	Reviser(s)
10-05-2011	1.1	Revised mean gage height calculation methods in rapidly fluctuation stage conditions.	6.9	J.R. Shedd
		Changed field procedure for assigning quality ratings to discharge measurements.	6.11	
		Updated citations and reference to 2010 edition of EAP Safety Manual.	9.3	
		Removed duplicate paragraph 6.8.3 and renumbered following paragraphs in proper sequence through rest of section.	6.8	
		Added double spacing between paragraphs 6.15.1 and 6.15.2,	6.15	
12-08-2014	1.2	Added method entitled Calculating Discharge When Measurement Location is Considerable Distance from the Gage	6.11	J.R. Shedd
		Added reference to publication cited in section 6.11.	9.5	
		Removed language stating uses of ADCPs are not appropriate in moving bed conditions.	6.3.3.5	
		Removed language referencing out dated QWin discharge calculation program.	6.15.2	
		Added language stating HYGAUGE program calculates discharge using Midsection method.	6.15.2	
		Updated citations and reference to 2012 edition of EAP Safety Manual.	8.0, 9.3	
		Made grammatical and formatting adjustments, rephrased language throughout document.		
12-08-2017	1.3	Made grammatical and formatting adjustments, rephrased language throughout document.		J.R. Shedd

## Environmental Assessment Program

### Standard Operating Procedure for Measuring and Calculating Stream Discharge

#### **1.0 Purpose and Scope**

- 1.1 This standard operating procedure describes the techniques and methods used to measure and calculate stream discharge in a variety of measurement conditions.

#### **2.0 Applicability**

- 2.1 The procedures presented in this document apply primarily to stream discharges measured with mechanical instruments and acoustic velocimeters. However, some sections including but not limited to; Cross Section Selection, Measurement Rating Guidelines, and Assessing the Control also apply to discharges measured with acoustic profilers.

#### **3.0 Definitions**

- 3.1 Midsection Method – A widely used technique for calculating stream discharge, the midsection method involves the calculation of discharge in individual measurement cells in a cross section. The sum of the discharges of each cell comprise the total discharge of the stream.
- 3.2 Cross Section – A vertical plane extending from either stream edge, up from the stream bottom to the surface. Depth measurements and velocity samples are taken at about 30 predetermined verticals across the cross section.
- 3.3 Vertical – One of a series of measurement points through the cross section where depth and velocity are measured.
- 3.4 Primary Gage Index –The base gage for the station directly referenced to the recording gage. The most stable and reliable gage at a site. All other gages at a station are considered secondary.
- 3.5 Control – The physical features of a stream controlling the relationship between stage and discharge at a gage site.
- 3.6 Point of Zero Flow –The elevation of the lowest point of a control structure. Flow stops when stage reaches the point of zero flow elevation.

#### **4.0 Personnel Qualifications/Responsibilities**

- 4.1 Personnel using this document will have the training necessary to operate current meters and related equipment. Staff will have knowledge of field and safety procedures associated with the collection of stream flow information.
- 4.2 Users of this document typically work in the Environmental Specialist or Hydrogeologist job classifications.
- 4.3 No special certifications currently required.

#### **5.0 Equipment, Reagents, and Supplies**

- 5.1 A standard English four-foot, top-set wading rod measures vertical depths in streams shallow enough and safe for wading. A velocity meter attached to the top set wading rod measures current speed. The design of the rod allows users to set the current meter at 0.2, 0.6, and 0.8 of the total stream depth.
- 5.2 The Sontek® FlowTracker® Acoustic Doppler Velocimeter® is used in the majority of wading measurements. The basic components of the FlowTracker® include the under water probe containing the acoustic elements, the probe cable, keypad, and controller (Burks, 2015). All of these components attach to a wading rod.
- 5.3 The primary mechanical current meter used in wading measurement applications is the Swoffer®, Inc. Model 2100® flow meter kit. The flow meter kit consists of a model 2100® digital indicator, sensor cable, and a two-inch rotor assembly (Holt, Shedd, 2016).
- 5.4 In the case of measurements from a bridge using mechanical equipment, we use a bridge board or bridge crane. These apparatuses use three types of sounding reels; USGS Type A and B reels and a Hydrological Services® Pty Ltd San Winch®. The Swoffer® flow meter kit (including counter) and the Hydrological Services® OSS-B® current meter serve as the mechanical instruments used in bridge measurements. The Hydromate® counter registers velocities for the OSS-B1 current meter (Holt, Shedd, 2016).



**Figure 1. Bridge board equipped with a USGS Type A reel. (Photo by Washington Dept. of Ecology)**



**Figure 2. Bridge crane equipped with a USGS Type B reel. (Photo by Washington Dept. of Ecology)**

5.5 Shore operated cableway discharge measurements require the use of a removable sounding reel, permanently installed bearing posts, main tow cable, pulleys, trolley, and related hardware.



- 5.6 Discharges measured from a boat require specially made equipment. This equipment includes a crosspiece, retractable boom, and a nose piece. A Kevlar® tag line maintains the position of the boat along a cross section.



**Figure 3. A boat measurement conducted with necessary equipment attached to a Kevlar® tag line. (Photo by Washington Dept. of Ecology)**

- 5.7 Columbus sounding weights, ranging from 15 to 100 pounds attach to the cable of the sounding reels in bridge, cableway, and boat measurements.
- 5.8 Copies of form number 040-56 (Appendix A) for recording discharge notes are stored with a suitable field notebook. These forms are printed on Rite in the Rain™ paper for outdoor durability.
- 5.9 A fiberglass measuring tape or marked cable stretches across the measurement cross section or bridge span.
- 5.10 Field staff wear good quality hip or chest waders when conducting discharge measurements by wading.
- 5.11 As mandated by the Environmental Assessment Program's Safety Manual (EAP, 2017) staff wear an approved personal flotation device when working in areas where the danger of drowning exists, such as on the water, over the water, or alongside the water.

## **6.0 Summary of Procedure**

### **6.1 Preparation**

- 6.1.1 Prior to departure complete a Field Work Plan.
- 6.1.2 Review the equipment checklist (Appendix B) and ensure all field and safety equipment are in the vehicle. Make sure all station information, instructions, and

field forms are on hand. Test all stream discharge measuring equipment for proper operation.

- 6.1.3 Ensure vehicle is equipped to handle the potential driving conditions to and from field destination. Make sure vehicle operates properly before leaving. Check oil level, fluid levels, and tire pressure.

## 6.2 Measurement Notes

- 6.2.1 Field staff must record clear, detailed notes prior to, during, and after the measurement. Future evaluations of a measurement depend on complete and thorough notes. Record the following information at each discharge measurement:
  - 6.2.1.1 Name of station and station number.
  - 6.2.1.2 Party (person conducting measurement listed first, person recording notes listed second).
  - 6.2.1.3 Note times of gage-height observations and logger recordings associated with the measurements in the Gage Readings table on the measurement note sheet. Record all times using 24-hour clock in Pacific Standard Time.
  - 6.2.1.4 In addition note the REW (right edge of water) and LEW (left edge of water). Orient right and left edges of water looking downstream.
  - 6.2.1.5 Identify the type of instrument, and record the instrument number. If using mechanical equipment, note the propeller or fan number.
  - 6.2.1.6 Record pre- and post-calibration readings if applicable (Holt, Shedd, 2016).
  - 6.2.1.7 Record the gage height from the primary and secondary gage indices at the beginning and end of the measurement. Additionally, observe and note the gage height at least once during the course of the measurement to determine if stage is changing.
  - 6.2.1.8 Record the variability in gage height observations, i.e. the range of water level bounce on a staff gage or the range of wire weight gage readings due to wave action. Record variability in +/- *n* hundredths of a foot.
  - 6.2.1.9 At stations equipped with continuously recording data loggers, record the time beside the corresponding vertical in the measurement notes every 15 minutes. These time observations are important in determining the mean gage height if stage changes significantly during the measurement. In the case of stations without a continuous recorder, observe and note the gage height manually when stage changes rapidly.

- 6.2.1.10 Record the water temperature particularly when using acoustic instruments.
- 6.2.1.11 Record width, area, average velocity, and maximum depth. Also include the number of verticals, wetted perimeter, and discharge.
- 6.2.1.12 Record velocity uncertainty, depth uncertainty, and overall uncertainty in the space provided on the note sheet.
- 6.2.1.13 Thoroughly describe flow, channel, cross section, and control conditions. Include descriptions of substrate materials, level of turbulence, areas of slack water and eddies, as well as flow distributions through the cross section. Note the presence of boulders, logs, and other barriers influencing depth and velocity measurements. Also note ice, vegetation, or debris present in the cross section or channel. Describe the shape of the channel and note any upstream or downstream structures affecting velocities and flow angles. Refer to section 6.13.6 for direction on documenting control conditions.
- 6.2.1.14 Describe any condition affecting the accuracy of the measurement or stage and discharge relationship.
- 6.2.1.15 At the end of the measurement indicate the rating of the measurement in the space provided on the note sheet.
- 6.2.1.16 Measure and record the point of zero flow if possible.
- 6.2.1.17 Prior to submittal of notes for review, enter the measurement number, and initials of person compiling notes in the space provided on the note form.
- 6.2.1.18 The person reviewing the measurement enters their initials in the space provided on the note form.
- 6.2.1.19 Record vertical locations, depths, and velocities on the back side of the measurement note form. Record velocities in the proper two-tenths, six-tenths, or eight-tenths column.
- 6.3 Selecting the Correct Instrument to Conduct a Discharge Measurement
- 6.3.1 Not all available measurement equipment is designed for use in all measurement situations.
- 6.3.2 Acoustic Doppler Current Profilers (ADCP) makes an attractive instrument choice because of their convenience and relative ease of deployment. If used appropriately ADCPs provide a more complete and accurate measurement.

- 6.3.3 However, ADCPs are not designed for use in every measurement situation. The following are circumstances in which an ADCP is not an appropriate instrument choice:
- 6.3.3.1 Poor depth distribution.
  - 6.3.3.2 High turbulence.
  - 6.3.3.3 Aerated water.
  - 6.3.3.4 Soft or vegetal covered substrate.
  - 6.3.3.5 Debris or fish in the water.
  - 6.3.3.6 Extremely clear water with very little or no turbidity or entrained material.
- 6.3.4 As a matter of practice, field staff ought to review the quality of past ADCP measurements at a site before deploying the instrument. Consider using another type of instrument or changing measurement locations if problems exist with past measurements.
- 6.3.5 Refer to The Teledyne RD Instruments® (TRDI) StreamPro® Standard Operating Procedure, Version 1.1 (Shedd, et al., 2016) or the WinRiver II Quick Start Guide (TRDI, 2007) for detailed information regarding the proper use of current profilers.
- 6.3.6 In inappropriate circumstances for use of an ADCP, use either an acoustic velocimeter or a mechanical instrument.
- 6.3.7 FlowTracker® velocimeters are preferred over mechanical equipment because of their accuracy, automatic discharge calculation capabilities, statistical presentation of data quality parameters, and lack of moving mechanical parts. The versatility of acoustic velocimeters makes them useful in most wading measurement applications. However, like the ADCP, the velocimeter will not work in all measurement situations.
- 6.3.8 Boulders, logs, or other large structures collectively referred to as boundaries cause interference with acoustic signals. This interference precludes velocity measurements with velocimeters. Avoid cross sections with significant boundary structures.
- 6.3.9 Very clear water with very little or no turbidity is another condition precluding velocity measurements with these instruments.
- 6.3.10 Highly turbulent or aerated water can also prohibit the use of the velocimeter.

- 6.3.11 Mechanical equipment will perform in almost all situations except in velocities less than about 0.10 feet per second. However, the same factors that preclude the use of acoustic instruments may also limit the reliability of mechanical equipment.
- 6.3.12 If a velocimeter proves unusable because of channel and flow conditions, attempt to find a more favorable measurement location. Use mechanical equipment only when circumstances preclude the use of acoustic equipment.
- 6.3.13 At the time of the recertification of this standard operating procedure the Freshwater Monitoring Unit is considering the use of Marsh-McBirney® velocity meters. Incorporating these instruments requires additional testing by the FMU. A review of an upcoming report on tests conducted by USGS at their Hydrologic Instrumentation Facility will also inform the decision to make use of Marsh-McBirney velocity meters.
- 6.4 Selecting a Cross Section
- 6.4.1 Before conducting a stream discharge measurement, field staff make considerable efforts to locate the best available measurement cross section. Conduct the measurement from a bridge, cableway, or boat if unable to wade the stream or conditions preclude the use of an ADCP.
- 6.4.2 In the case of ADCP and wading measurements one cannot over emphasize the importance of selecting a suitable cross section. The quality of equipment or the ability of the individuals conducting the measurement cannot overcome the limitations in measurement quality caused by a poor cross section. The choice of cross sections is obviously limited when measuring from a bridge, cableway, or boat.
- 6.4.3 Field staff look for the following characteristics in an ideal measurement cross section (Rantz, 1982):
- 6.4.3.1 A stream channel relatively straight with parallel edges upstream and downstream of the cross section.
- 6.4.3.2 Defined edges on both sides of the cross section.
- 6.4.3.3 A channel of uniform shape.
- 6.4.3.4 A channel free of vegetative growth, large cobbles, and boulders.
- 6.4.3.5 A cross section free of eddies, slack water, and turbulence.
- 6.4.3.6 A cross section with depths greater than 0.5 feet.
- 6.4.3.7 Velocities greater than 0.5 feet per second and distributed evenly through the cross section.

6.4.3.8 A cross section relatively close to the gaging station control to avoid the inflow of tributaries and differences in relative flow between the control and cross section during periods of changing stage.

6.4.4 Meeting all of the selection criteria is often not possible. Field staff should choose the best available cross section based on these characteristics.

## 6.5 Dividing the Stream Channel into Segments

6.5.1 After locating a satisfactory cross section, stretch a measuring tape or marked tag line across the measurement cross section. The tape or tag line extends across the channel perpendicular or normal to the direction of flow. Limit the number of cells with oblique flow angles, i.e. cells with current angles not perpendicular to the cross section.

6.5.2 Note the width of the stream channel at the cross section and divide into measurable segments or cells. Divide the cross section such that approximately five percent and no more than ten percent of the total flow comprises any one segment. In most cases, divide the cross section into approximately 30 segments. Position verticals closer together where flow is more concentrated and velocity variation or bottom irregularities are greatest.

6.5.3 The width of a measurement segment should not be less than three tenths of a foot.

## 6.6 Measuring Velocity

6.6.1 Measure velocity at each predetermined vertical across the stream. Although evenly distributed in ideal cross sections, velocity can vary significantly in less-than-ideal cross sections. Velocity varies horizontally across the cross section and vertically through the water column. Velocity also naturally pulses in streams at any single location over short periods of time.

### 6.6.2 *Horizontal Velocity Variation*

6.6.2.1 Channel geometry, substrate, and other stream features cause horizontal variability between stream segments. Field staff can minimize measurement uncertainty due to horizontal velocity variation by applying these guidelines:

6.6.2.1.1 Divide the stream cross section into about 30 segments. If previous measurements show uniformity of the cross section and an even velocity distribution, fewer verticals are permissible (Rantz, 1982).

6.6.2.1.2 Concentrate the distribution of segments where discharge is highest and in areas where significant velocity variation occurs.

6.6.2.1.3 Increase the number of verticals in vicinity of bridge piers.

### 6.6.3 *Vertical Velocity Variation*

6.6.3.1 In most natural stream conditions, a logarithmic relationship exists between velocities through the water column. Typically, velocities are highest in the upper portion of the water column and lower near the bottom. Address vertical velocity variability within a segment using one of the following methods, depending on measurement conditions.

6.6.3.1.1 Six-tenths method: Sample velocities at sixth tenths of the depth from the water surface. Assume velocity samples at six tenths of depth represent the average velocity through the water column. Use the six-tenths method at stream segments less than 1.5 feet in depth. Use the six-tenths method at all depths when stage is fluctuating rapidly.

6.6.3.1.2 Two-point method: Employ the two-point method at depths greater than or equal to 1.5 feet. Calculate the average of velocities sampled at two tenths and eight tenths of the depth.

6.6.3.1.2.1 When measuring from a bridge, cableway, or boat, use the two-point method at depths greater than or equal to 2.5 feet.

6.6.3.1.3 Three-point method: The three-point method consists of velocity samples at two tenths, six tenths, and eight tenths of depth. Use the three-point method when a logarithmic relationship does not exist between strata of velocities through the water column.

6.6.3.1.3.1 Presume a non-logarithmic relationship exists when the two-tenths velocity is less than the eight-tenths velocity or the two-tenths velocity is greater than two times the eight-tenths velocity.

6.6.3.1.3.2 To calculate the average velocity for the vertical, average the six-tenths velocity sample against the mean of the eight-tenths and two-tenths velocity samples, thus weighting the six-tenths sample as half of the calculated velocity for the vertical.

### 6.6.4 *Single-Point Velocity Variation*

6.6.4.1 Stream velocities in natural conditions tend to pulse over time at the same stage. These fluctuations compound the effects of horizontal and vertical velocity variability at fixed locations in the stream. Apply the following guidelines to address single-point velocity variability:

6.6.4.1.1 Take 40-second velocity samples to address variations in velocity over time at a single measurement point.

6.6.4.1.2 Measure 40-second velocity samples at each measurement point, except when stage rapidly fluctuates or when velocities less than 0.5 feet per second exist when measuring with mechanical instruments.

- 6.6.4.1.3 In circumstances when stage fluctuates significantly, take single 20-second velocity samples to complete the discharge measurement quickly.
- 6.6.4.1.4 When using mechanical equipment, increase the sample time to 60 seconds when velocity is less than 0.5 feet per second.
- 6.7 Adjusting Velocities of Oblique Flow Angles
- 6.7.1 Pay close attention to the direction of flow when using mechanical current meters. To calculate discharge correctly determine the velocity of the current normal or perpendicular to the cross section.
- 6.7.2 The following procedure does not apply to SonTek® velocimeters as they are always pointed perpendicular to the cross section. SonTek® velocimeters automatically calculate and report velocity as normal to the cross section (Burks, 2015).
- 6.7.3 Ecology's Freshwater Monitoring Unit's mechanical instruments consist of horizontal axis type current meters. In wading measurements, point mechanical meters into the current when the angle of the current, relative to the perpendicular of the cross section is greater than 15 degrees. When suspended by a cable, the meter will automatically point into the current.
- 6.7.4 At any measurement vertical, when a mechanical meter is pointed into an oblique current greater than 15 degrees from the perpendicular of the cross section, multiply the registered velocity by the cosine of the angle. This calculation yields velocity normal to the cross section. An approximate 3.5 percent difference exists between registered velocity at a 15-degree current angle and the calculated velocity normal to the cross section. A 20-degree angle results in a greater than 6-percent difference between registered and calculated velocity normal to the cross section.
- 6.7.5 Determine the cosine in the field with the use of the Ecology Discharge Measurement Note sheet number 040-56 (Appendix A).
- 6.7.5.1 On the back side of the form, locate the dot in the center of the left margin. Cosine values are on the right side of the page as well as the top and bottom. Hold the note sheet horizontally with the dot over the measuring tape if wading or the edge of a bridge rail if conducting a bridge measurement. Position the note sheet such that the long edge of the sheet is parallel to the direction of the current. The measuring tape or bridge rail edge will intersect the cosine value on the right



edge, top, or bottom of the sheet. Multiply the cosine value by the registered velocity to obtain the velocity normal to the cross section.

- 6.7.5.2 In many instances when measuring discharge from a bridge, the entire stream channel is at an oblique angle to the cross section defined by the bridge. In this case, multiply the raw average velocity of the measurement by the cosine of the angle between current direction and the cross section defined by the bridge.

## 6.8 Measuring Discharge When Stage Fluctuates Rapidly

- 6.8.1 Field staff should streamline measurement methods to obtain a more representative gage height when stage changes rapidly. Some accuracy in the measurement is sacrificed. However, the error caused by changing flow patterns in rapidly changing stage situations is greater than the loss of accuracy in a streamlined discharge measurement (Buchanan and Somers, 1969).

- 6.8.2 Generally, rapidly changing stage occurs when stage fluctuates at a rate greater than 0.1 feet per hour. Be aware that measurements conducted during or after storm events, impoundment or diversion activities, or seasonal snow melt periods are the most likely times to encounter rapidly changing stage conditions. When stage fluctuates rapidly:

- 6.8.2.1 Measure velocities using the six-tenths method regardless of depth.

- 6.8.2.2 If the six-tenths method is not possible, use either the two-tenths, subsurface, or surface methods presented in section 6.10.

- 6.8.2.3 Reduce velocity sampling time to 20 seconds.

- 6.8.2.4 Reduce the number of verticals to 15 or 20.

- 6.8.2.5 At sites with continuous stage height recorders, record the time every 15 minutes on the note sheet corresponding to the vertical measured at that time.

- 6.8.2.6 In the case of non-recording stations, manually read and note gage heights. Record observation times on the note sheet next to the corresponding vertical.

- 6.8.2.7 Use this record of stage and corresponding observation times in the calculation of a weighted mean gage height.

## 6.9 Calculating Mean Gage Height When Stage Fluctuates Rapidly

- 6.9.1 The mean gage height of a discharge measurement and the discharge value itself comprise the two plotted coordinates used to establish a rating. An accurate

determination of mean gage height is as important as the accuracy of a discharge measurement.

- 6.9.2 At continuous-recording stations check the stage record during the time of the measurement against the recorded times on the measurement sheet. Check the record for the amount of fluctuation in stage during the measurement.
- 6.9.3 If changes in stage occurred during the measurement and the changes are uniform and less than about 0.1 feet, determine mean gage height by calculating the average of the beginning and ending gage height readings (Buchanan and Somers, 1969). Use judgment in determining the allowable change in gage height where a simple mean gage height is calculated. Consider the percentage of discharge the change in stage represents at smaller streams.
- 6.9.4 If stage changes by greater than 0.1 feet or changes unevenly, calculate a weighted mean gage height for the measurement. We use two methods to obtain a weighted mean gage height. The first, called Partial Discharge Weighting, we only use with discharges measured with mechanical equipment or acoustic velocimeters. The second method, Time Weighting, we use with all measurement equipment including Acoustic Doppler Current Profilers. When we use mechanical equipment or acoustic velocimeters, we employ both methods and calculate the average of the separate results to obtain a weighted mean gage height.
- 6.9.4.1 With the Partial Discharge Weighting method, use the discharge between recorded times during the measurement, the mean gage height for the corresponding time periods, and the total measured discharge to compute a mean gage height. The Partial Discharge Weighting formula follows:

$$H = \frac{q_1 h_1 + q_2 h_2 + q_3 h_3 \dots + q_n h_n}{Q}$$

where

H = mean gage height

Q = total discharge =  $q_1 + q_2 + q_3 \dots + q_n$

where  $q_1 + q_2 + q_3 \dots + q_n$  = discharge measured during time interval 1, 2, 3, ...n and

$h_1 + h_2 + h_3 \dots + h_n$  = average gage height during time interval 1, 2, 3, ...n.

- 6.9.4.1.1 Figure 4 presents an example of a partial discharge weighting calculation. The gage height is recorded every 15 minutes from 13:30 to 14:30. The average gage height (h) is calculated between each 15-minute interval. The sum of the discharges of each cell (q) measured in the 15-minute interval is computed. Each of these discharges are summed to give  $Q = 76.37$ . Calculate the product  $h \cdot q$  and sum the products to give  $\text{Sum}(h \cdot q) = 135.43$ . To calculate the mean gage height

H, divide Sum (h\*q) by Q in the form  $\frac{135.43}{76.37}$  to give a mean gage height of 1.77 feet.

Example:

Time	Gage Height	h	q	h*q
13:30	1.94	<b>1.92</b>	<b>16.1</b>	<b>30.91</b>
13:45	1.90	<b>1.70</b>	<b>24.31</b>	<b>41.33</b>
14:00	1.49	<b>1.67</b>	<b>20.99</b>	<b>35.05</b>
14:15	1.85	<b>1.88</b>	<b>14.97</b>	<b>28.14</b>
14:30	1.92			
<b>Q = 76.37</b>		<b>Sum (h*q) = 135.43</b>		

$$H = \frac{135.43}{76.37} = 1.77 \text{ feet}$$

**Figure 4. Example of partial discharge weighting calculation method.**

6.9.4.2 The Time Weighting method uses the mean gage heights between the noted times, the duration of those times, and the total time of the measurement. The Time Weighting formula is

$$H = \frac{t_1 h_1 + t_2 h_2 + t_3 h_3 \dots + t_n h_n}{T}$$

where

H = mean gage height

T = total time for the measurement, in minutes =  $t_1 + t_2 + t_3 \dots t_n$ ,

$t_1, t_2, t_3 \dots t_n$  = duration of time intervals between gage height observations, and

$h_1, h_2, h_3 \dots h_n$  = average gage height during time interval 1, 2, 3, .n.

6.9.4.2.1 In the example below the average gage heights (h) from the discharge weighting example are used. The product of each time interval between gage height readings (t) and (h) are calculated to give h \* t. The four 15-minute time intervals in the example are added to give a total time of 60 minutes. The products of h \* t are summed to give a total of 107.55. The summed products of h \* t are divided by the total time in the form  $\frac{107.55}{60}$  to give a mean gage height of 1.79 feet.

Example:

h	Time interval (t)	h * t
1.92	15	28.80
1.70	15	25.50
1.67	15	25.05
1.88	15	28.20
Total	60	107.55

$$H = \frac{107.55}{60} = 1.79 \text{ feet}$$

**Figure 5. Example of time weighted calculation method.**

6.9.5 Studies by the United States Geological Survey (USGS) indicate the Partial Discharge method tends to overestimate the mean gage height and the Time Weighted method underestimates the mean gage height. For that reason, the USGS recommends computing both methods and averaging the two results (Rantz, 1982). Keep in mind the use of both methods only apply to measurements where mechanical instruments or acoustic velocimeters were used. Mean gage height calculations with ADCP measurements only work with the Time Weighted method. In the above examples, the mean stage for the measurement using the results of both methods calculates to 1.78 feet.

#### 6.10 Measurement and Calculation Techniques When High Velocities Preclude Depth Soundings or Conventional Velocity Observations

6.10.1 If velocity is too great to make depth soundings or obtain conventional velocity samples, three alternative methods make discharge estimations possible. These include the two-tenths, the subsurface velocity, and the surface velocity methods.

##### 6.10.2 *Two Tenths Velocity Method*

6.10.2.1 Calculation of velocity using the two-tenths depth method involves sampling velocity at 0.2 of the depth from the surface and applying a coefficient derived from the point to mean velocity ratio. The point to mean velocity ratio refers to the calculated or estimated ratio between the measured velocity at two-tenths depth and the mean velocity of the entire water column.

6.10.2.2 In circumstances where depths can be reliably sounded but velocity cannot be sampled at 0.6 or 0.8 of depth because of drift debris or other reasons, sample velocity at 0.2 of the measured depth.

- 6.10.2.3 Coefficients applied to two tenths depth velocities are most reliable when derived from velocity curves from the specific location as opposed to published velocity curves. Develop a velocity curve between two-tenths velocities and true mean velocities by recalculating past measurements. Recalculate complete measurements or measurement segments where 0.8 and 0.2 depth velocity samples were measured, using only the 0.2 velocity in the calculation. By plotting the true mean velocities versus the two-tenths velocities for each measurement we can derive a mathematical relationship.
- 6.10.2.4 Studies conducted by USGS indicate that for a given cross section the relationship between the two tenths and true mean velocities remains constant or varies uniformly with stage (Rantz, 1982).
- 6.10.2.5 USGS Water Supply Paper 2175 (Rantz, 1982) provides a vertical velocity graph and table of point to mean velocity ratios. This graph and table were developed through intensive study of vertical velocity curves. If an insufficient number of measurements have been conducted to derive a reliable relationship at a specific site, we can use the replicated graph (figure 6) and table 1 to calculate point velocities. We derive the point velocity from the table by dividing the measured velocity by the ratio of point velocity to mean velocity. For example the ratio applied to a velocity measured at 0.2 of depth is calculated in the form  $\frac{v}{1.149}$  where v is the measured velocity and the denominator of 1.149 is the ratio of point velocity to mean velocity at 0.2 of depth found on Table 1.

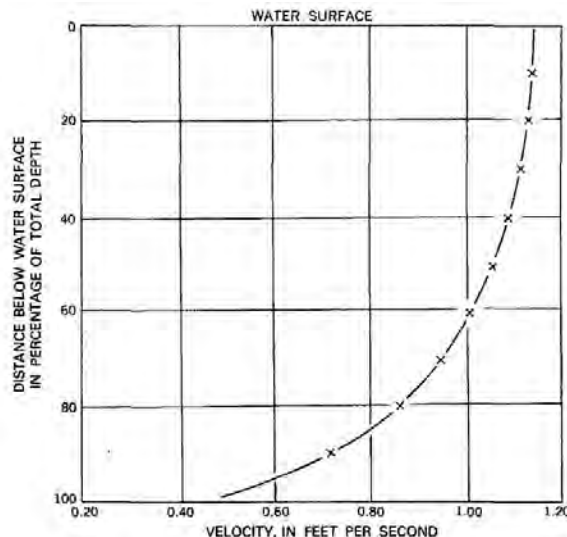

**Figure 6. Graphical representation of standard vertical velocity curve developed by USGS. (Illustration from USGS Water Supply Paper 2175, pg. 133.)**

**Table 1. Point to mean velocity ratios for standard vertical velocity curve.**

**(Table from USGS Water Supply Paper 2175, pg. 133.)**

Ratio of observation depth to depth of water	Ratio of point velocity to mean velocity in the vertical
0.05	1.160
.1	1.160
.2	1.149
.3	1.130
.4	1.108
.5	1.067
.6	1.020
.7	.953
.8	.871
.9	.746
.95	.648

6.10.3 *Subsurface Velocity Method*

6.10.3.1 Use the subsurface velocity method if measuring or estimating depth is not possible or practical.

6.10.3.2 Mark start and end points of the cross section in order to locate the same measurement verticals at a later measurement. Sample velocities at an arbitrary depth at least two feet below the surface.

6.10.3.3 Determine depths by soundings made at a later measurement when the flow has receded. Calculate the difference between the gage heights of the two measurements to estimate depths and meter elevations at the time of the subsurface velocity measurement. Compare cross sections of previous measurements with the cross section of the latest measurement to determine if the cross section has shifted (Buchanan, Somers, 1969).

6.10.3.4 With the known depths of the current meter, compute the ratio of point of velocity observation to vertical depth.

6.10.3.5 As previously described, we can obtain point velocity to mean velocity ratios from velocity curves developed for the specific site. Use the graph in Figure 6 and Table 1 if a velocity curve specific to the site is not available.

6.10.3.6 A simple example of this application follows: Based on soundings subsequent to a subsurface velocity sample at a certain vertical, the depth at the time of the sample is calculated at 10 feet. Velocities were sampled at three feet below the surface. The ratio of the point of velocity observation to vertical depth is  $\frac{3\text{feet}}{10\text{feet}} = 0.3$ . Table 1 shows the ratio of point velocity to mean velocity in the vertical at 0.3 of depth is 1.13. Calculate the adjusted velocity at 0.3 of depth in the form  $\frac{v}{1.13}$  where v is the measured velocity and the denominator 1.13 is the ratio of point velocity to mean velocity.

#### 6.10.4 *Surface Velocity Method*

6.10.4.1 If not practical or possible to obtain velocities below the surface, use the surface velocity method. Lower the meter to just below the water surface to sample the velocity. The coefficient used to calculate mean velocity is 0.85, or divide the sampled velocity by 1.18 (Rantz, 1982).

#### 6.11 Calculating Discharge When Measurement Location is Considerable Distance from the Gage

6.11.1 In some instances significant distance separates the measurement location from the gage. When water surface elevations in a long stream reach with no tributaries are steady, discharge along the reach remains near constant. However as water surface elevations change, discharges can vary greatly along the reach due to channel storage effects. Channel storage effects occur as water surface elevations rise or fall in a reach. As the water surface elevation rises, some water goes into storage. As water surface elevation falls water comes out of storage. Discharge is greater at the inflow than the outflow of a reach as water goes into storage. Conversely discharge is greater at the outflow than the inflow when water comes out of storage. The degree of channel storage effect in a given reach depends on channel shape, sinuosity, roughness, slope, influences of control structures among other factors. Figure 7 shows a hypothetical stream reach illustrating channel storage effects.

6.11.2 When changes in water surface elevation occur between the gage and measurement locations, we must determine the differences in discharge. The objective in accounting for these differences is to determine the discharge at the gage at the time of the measurement.

6.11.3 Use the channel storage calculation method presented below anytime the possibility exists of a difference in flow between the measurement location and gage. Keep in mind the channel storage calculation cannot account for inputs of tributaries, losses to diversions, gains from irrigation returns, as well as gains and losses from groundwater interactions within the reach.

6.11.4 The rate of change in the water surface elevation and average water surface area in the reach defines the relationship between the inflow and outflow and serves as the basis for the channel storage equation (Kennedy, 1984).

6.11.5 The channel storage equation:

$$Q_i - Q_o = \frac{L \times W \times J}{3,600}$$

where

$Q_i$  is inflow in cubic feet per second,  
 $Q_o$  is outflow in cubic feet per second,  
 $L$  is the length of the reach in feet,  
 $W$  is the average width of the reach in feet, and  
 $J$  is the average rate of change of the water surface elevation through the reach in feet per hour (expressed as positive for a rising water surface elevation, negative for falling water surface elevation). The value of  $J$  computes as follows:

$$J = (60/t) \frac{\pm S_i + \pm S_o}{2}$$

where

$t$  is the elapsed time of the measurement in minutes,

$S_i$  is change in stage at inflow, and

$S_o$  is change in stage at outflow.

Since  $J$  is the rate of change in feet per hour. The use of the divisor 3,600 (the number of seconds comprising one hour) in the channel storage equation expresses  $Q$  in cubic feet per second.

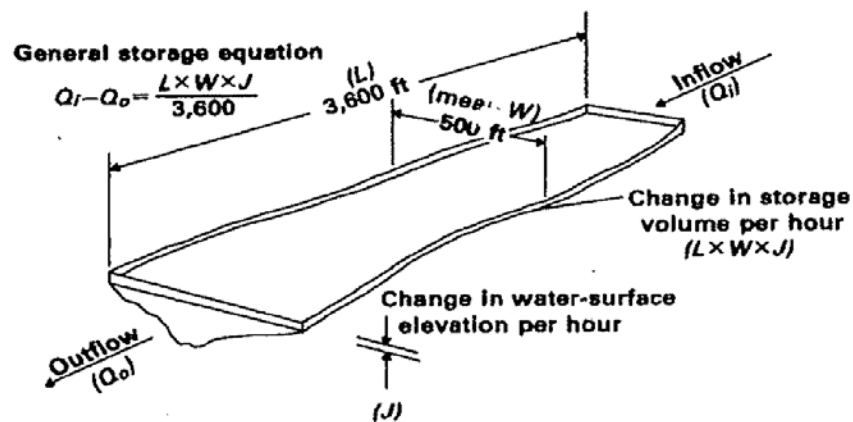

**Figure 7. Hypothetical stream reach illustrating channel storage effects. (Illustration from USGS Publication, Discharge Ratings at Gaging Stations, pg. 3.)**

#### 6.11.6

Using the stream reach dimensions in Figure 7, suppose we establish a gage at the outflow of the reach and the measurement cross section located upstream at the inflow. Further suppose the measured discharge at the inflow was 1,000 cfs and the water surface fell 0.6 feet at the measurement site and 0.4 feet at the downstream gage for an average change in water surface elevation through the reach of -0.50 feet. The hypothetical measurement took one hour to complete. Again, the objective is to determine the discharge at the gage.



6.11.7 Applying the channel storage equation to the dimensions of the hypothetical stream reach, with the provided measured discharge and water surface change information, compute the outflow discharge as

$$1,000 - Q_o = \frac{3,600 \times 500 \times \left( \left( \frac{60}{60} \right) \times \left( \frac{(-.6) + (-.4)}{2} \right) \right)}{3,600}$$

The calculated outflow discharge ( $Q_o$ ) at the gage = 1,250 cfs. This is an example of water coming out of channel storage because the calculated outflow is greater than the measured inflow.

6.11.8 At the same hypothetical stream reach, suppose the gage this time is located at the inflow and 2,000 cfs was measured downstream at the outflow. The average change in water surface elevation was 0.30 and the measurement took 45 minutes to complete. We compute the inflow discharge at the gage as

$$Q_i - 2,000 = \frac{3,600 \times 500 \times \left( \left( \frac{60}{45} \right) \times 0.30 \right)}{3,600}$$

In this example the calculated inflow discharge ( $Q_i$ ) at the gage = 2,200 cfs. Here water goes into channel storage because the inflow is greater than the outflow.

6.11.9 In order to calculate, as accurately as possible, a discharge corresponding to the gage location, acquire the best possible measurements of reach length and average width. If practical, physically measure reach dimensions; otherwise use quadrangle maps, orthophotos, the StreamStats program, or other sources to determine reach width and length. Do not simply guess the dimensions of a reach.

6.11.10 Prior to conducting a measurement at a distant location from the gage, set an appropriate reference mark at the measurement location to determine change in water surface elevation over the course of the measurement. Changes in water surface elevations at the gage are determined by gage height observations or logger recordings before and after the measurement.

6.11.11 Enter the adjusted discharge value to the measurement record in the Gaugings Database in the Hydstra program. Assign the appropriate quality code to the calculated measurement value, keeping in mind the variables and potential uncertainty involved in determining discharge based on a measurement conducted at a distant location from the gage.

## 6.12 Rating a Measurement

- 6.12.1 At the conclusion of each measurement, field staff apply a rating of the measurement on a scale from excellent to poor. This field rating forms the basis of the final quality code assigned to the measurement by the station's principle investigator.
- 6.12.2 Field staff base the measurement rating on observed conditions, as well as quality analysis statistics available in the field. Acoustic velocimeters' and current profilers' operating systems offer comprehensive analytical packages.
- 6.12.3 The desirable characteristics of a measurement location found in section 6.4, *Selecting a Cross Section*, serves as the basis for rating the physical conditions of the channel and cross section. Field staff observe the degree to which each of these characteristics influence the quality of the measurement.
- 6.12.4 Take into account factors such as the proximity of bridges and other structures to the cross section. These structures can effect velocity distribution and uniformity of depth (Rantz, 1982).
- 6.12.5 Consider the number of corrected velocities because of oblique current angles. Keep in mind that the assumption that the angle observed at the surface prevails through the entire vertical may be incorrect. Numerous angles of flow approaching the cross section from various directions may indicate turbulence resulting in non-representative velocity samples.
- 6.12.6 Take notice of the condition of the equipment. Rate the measurement accordingly if problems with equipment occurred during the measurement.
- 6.12.7 Look at the role of the weather in the measurement. Wind over the water surface can obscure the direction of flow. Cold weather may cause ice or slush to form in the cross section. Ice or slush can adversely affect the operation of mechanical current meters and the ability to measure depth accurately.
- 6.12.8 Water level bounce and velocity pileup on wading rods and stadia rods adds uncertainty to depth determinations. Take into account these factors when rating a measurement.
- 6.12.9 Not all of the variables affecting the quality of a discharge measurement are described here. Field staff must consider all the conditions and use professional judgment in rating a measurement.
- 6.12.10 The principle investigator or basin lead thoroughly reviews all of the components of the field rating and renders the final decision in all quality code assignments. It is extremely important that field notes are thorough and complete.

- 6.12.11 Rate measurements as excellent, good, fair, or poor on the discharge note form. An excellent measurement indicates a measured discharge value within 2 percent of the actual flow value. A rating of good means the measured value is within 5 percent. A fair rating of a measurement indicates a measured value within 8 percent. Poor means the error in the measured flow is within 13 percent of the actual discharge.
- 6.12.12 Field staff do not consider the level of difficulty in obtaining gage height observations in the measurement rating. Base the rating solely on measurement conditions. However, field staff should focus particular attention in field notes on the circumstances and degree of difficulty in obtaining an accurate gage height observation. Consider water level bounce and velocity pileup on staff gages or stadia rods. Wind can cause wave action that may make it difficult to locate the water surface with wire weight gages and tapedown weights. The principle investigator considers these factors carefully in formulating the final rating.
- 6.12.13 In addition, when stage changes rapidly, some accuracy is lost when purposefully accelerating the measurement. Stage determinations in these circumstances are often calculated rather than directly observed. Rate the measurement appropriately in these circumstances.
- 6.13 Assessing the Control
- 6.13.1 The physical features of a stream that regulates the relationship between stage and discharge at a gage site is the control.
- 6.13.2 Section control, channel control, and flood plain control constitutes the three basic types of controls. The following discussion focuses on section and channel controls.
- 6.13.3 *Section Control*
- 6.13.3.1 A section control governs the stage and discharge relationship in a localized reach of the stream, downstream from the gage. The section control can be a natural or artificial structure, a channel constriction, or a downward break in slope in the stream bed.
- 6.13.3.2 Common section control structures include the buildup of rocks and boulders or woody debris stretched across the channel. Manmade dams, weirs, or water diversion structures often serve as section controls. Channel constrictions can include rock outcrops or gravel bars. Bridges where the waterway opening is narrower than the natural channel is a common section control, causing channel constriction and regulating gage height. Downward breaks in the slope of a streambed include heads of riffles, cascades, or the brink of a falls.



**Figure 7. This section control is defined by the downward break in slope at the head of the riffle. (Photo by Washington Dept. of Ecology)**

6.13.3.3 At some stations we may find more than one section control. In these instances a section control closer to the station regulates the stage and discharge relation at lower stages. At higher stages another downstream section control becomes effective.

6.13.4 *Channel Control*

6.13.4.1 Channel control exists when the physical attributes of a long reach of the channel controls the relationship between stage and discharge. These physical attributes include shape, length, width, slope, sinuosity, and roughness of the channel. The length of the channel as an effective control increases as discharge increases (Rantz, 1982).



**Figure 8. An example of channel control at the same location as figure 7. (Photo by Washington Dept. of Ecology)**

#### 6.13.5 *Control Dynamics*

6.13.5.1 Typically, section control is effective at lower stages and channel control is effective at higher stages. An intermediate range of flows is subject to partial control. Partial control occurs when the relationship between stage and discharge is governed by both section and channel controls or by two separate section controls. As stage and flows increase, channel control progressively drowns out section control. Partial control also occurs between two section controls when stage increases, such that the downstream control becomes increasingly effective.

6.13.5.2 The propensity of the channel to change over time determines the stability of the station controls. If high flow events frequently cause scour or fill of a channel, the controls are unstable. If a control changes frequently, the stage and discharge relation changes frequently. If controls are stable, the stage and discharge relationship remains stable.

6.13.5.3 Ideally all stations would have stable controls. Unfortunately, this is not the case in the natural environment. Stations with unstable controls require frequent adjustment of rating curves. Unstable controls require additional measurements to establish new ratings rather than further define and reaffirm existing ones. More time is needed to manage records when ratings need frequent adjustment. This increases the costs to operate a station and can reduce the timeliness and reliability of discharge records.

#### 6.13.6 *Documenting the Condition of Controls*

6.13.6.1 Because controls may change over time, field staff must monitor and document the condition of controls at each discharge measurement. The station's principle

investigator will need detailed information about the control if a change in rating occurs.

6.13.6.2 Field staff should identify the effective control or if there is a partial control situation. If section control is in effect, note the location of the control relative to the gage. Note the type of section control, i.e., the control is a structure in the stream, or the control constricts flow like a gravel bar or outcrop. Note the materials making up the section control. Have copies of past notes or photos on hand to document changes in the control relative to previous visits.

6.13.6.3 Note any forms of seasonal vegetal growth or ice on or around the control and on the bed and banks. Aquatic vegetation and ice on the control or in the channel alters the stage and discharge relationship by reducing velocity and the effective waterway area (Rantz, 1982).

6.13.6.4 In autumn, the accumulation of leaves can temporarily change the stage and discharge relationship. Note the extent of accumulation of leaves on the control or in the channel where the stage and discharge relation may be impacted.

#### 6.14 Measuring the Point of Zero Flow

6.14.1 The point of zero flow (PZF) is the lowest point on a control and the stage at which flow ceases.

6.14.2 Identify and measure a PZF whenever possible. A determination of the PZF helps define the lower end of a rating and serves as a first estimate of the off-set of a rating.

6.14.3 A change in PZF elevation or location indicates alteration of the control. A measurable alteration in the control can signify a shift in the rating.

6.14.4 Attempt to measure a PZF only when safe to do so. Follow these steps to identify and determine a PZF:

6.14.4.1 Locate the section control.

6.14.4.2 Take depth soundings across the control with a wading rod.

6.14.4.3 Locate and measure the depth of the PZF, the deepest point of the control.

6.14.4.4 Include in the depth reading the pileup of water on the wading rod.

6.14.4.5 Note the depth of the PZF to the nearest one-tenth of a foot.

6.14.4.6 Note the locations of the control and the PZF.

- 6.14.4.7 Take photographs of the control.
- 6.14.4.8 Calculate PZF by subtracting the depth of the PZF from the gage height. Record PZF on the bottom of Form 040-56 (Appendix A).
- 6.14.5 Keep a record of PZF soundings and locations in station notes.
- 6.15 Calculating Stream Flow Using the Midsection Method
- 6.15.1 Ecology's Freshwater Monitoring Unit uses the midsection method to calculate streamflows measured with mechanical current meters or acoustic velocimeters.
- 6.15.2 The equations comprising the midsection method are written into a variety of computer programs. The SonTek® FlowTracker® contains a built-in midsection-calculation program to calculate discharge (Burks, 2015). In addition, the Hydstra Gaugings Calculator Program HYGAUGE uses the midsection method to calculate measured discharges conducted with mechanical instruments.
- 6.15.3 Although computation of discharge by hand is virtually unnecessary, an understanding of the midsection calculation method can influence strategies and decisions while conducting discharge measurements.
- 6.15.4 The midsection calculation method involves summing the discharges of the individual cells comprising the cross section. This is expressed in the following equation,  $Q = \sum(a v)$  where  
 Q = total measured discharge  
 a = area of individual cell  
 v = mean velocity of individual cell, normal to the cross section.
- 6.15.5 The discharge of an individual cell is the product of its area and mean velocity normal to the cross section.
- 6.15.6 The area of the cell extends laterally half the distance from the previous vertical to half the distance to the next. The area also extends vertically from the water surface to the sounded depth. Evenly spaced verticals are not necessary. The mean velocity sampled at the vertical represents the velocity through the entire cell.

6.15.7 The discharge of any cell at vertical x is represented in the equation,

$$q_x = v_x \left[ \frac{(b_x - b_{(x-1)})}{2} + \frac{(b_{(x+1)} - b_x)}{2} \right] d_x$$

$$= v_x \left[ \frac{b_{(x+1)} - b_{(x-1)}}{2} \right] d_x$$

where

$q_x$  = discharge through cell x,

$v_x$  = mean velocity at vertical x,

$b_x$  = distance from initial point to vertical x,

$b_{(x-1)}$  = distance from initial point to preceding vertical,

$b_{(x+1)}$  = distance from initial point to next vertical, and

$d_x$  = depth of water at vertical x.

6.15.8 For example, the discharge in highlighted cell 4 in figure 9 is expressed as

$$q_4 = v_4 \left[ \frac{b_5 - b_3}{2} \right] d_4.$$

6.15.9 The total discharge of the stream is equal to the sum of the discharges of each cell.

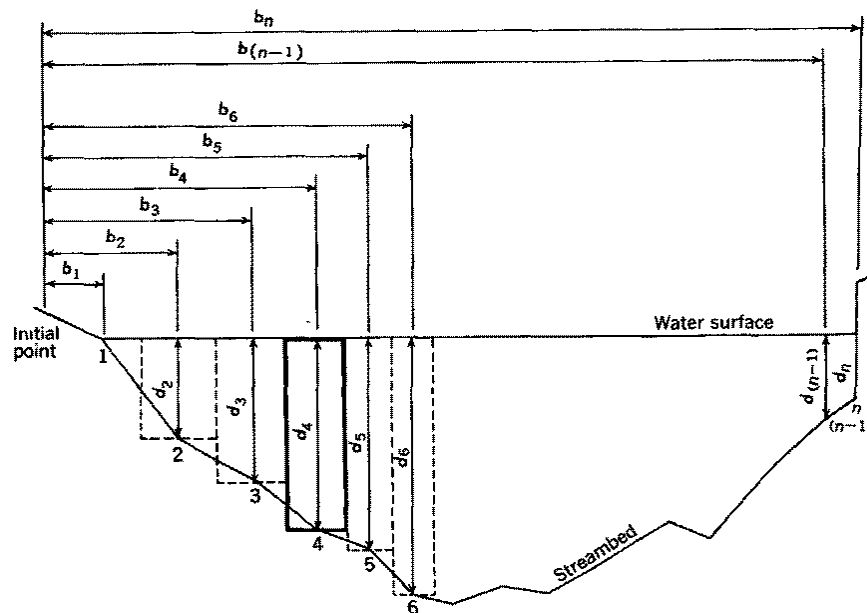

**EXPLANATION**

- |                             |   |
|-----------------------------|---|
| 1, 2, 3 ..... n             | Observation verticals   |
| $b_1, b_2, b_3, \dots, b_n$ | Distance, in feet or meters, from the initial point to the observation vertical |
| $d_1, d_2, d_3, \dots, d_n$ | Depth of water, in feet or meters, at the observation vertical                  |

**Figure 9. Cross-section sketch illustrates depth and distance between verticals that define the area of measurement cells. Velocities measured at these verticals represent the velocity of the cell. (Illustration from USGS Water Supply Paper 2175, pg. 81.)**



- 6.15.10 Observe in figure 9 the discharge of  $q_1$  is zero. This is because the depth of observation point 1 is zero. Actual discharge may or may not exist in this half-cell on the edge of the cross section. Typically, the amount of actual flow here is inconsequential. Place the first and last vertical as close to the edge as possible when the depth at the edge is zero. This ensures any residual, unmeasured flow remains insignificant.
- 6.15.11 Now observe vertical  $n$  at right edge of figure 9. Here the edge is a vertical boundary where the depth is greater than zero, and the velocity may or may not be zero.
- 6.15.12 Because we cannot measure velocity accurately at a vertical boundary, we estimate velocity at the boundary by measuring the mean velocity at a distance from the boundary equal to the depth at the boundary (Rantz, 1982).
- 6.16 Use of a Wading Rod
- 6.16.1 Ecology's Freshwater Monitoring Unit uses a standard four-foot top-setting wading rod in graduated English units. Top-setting wading rods have a 1/2-inch hexagonal rod to measure depth. The hexagonal rod is marked by single lines scored in one-tenth-foot graduations up the length of the rod. Every one-half foot is marked with double lines. At every one foot increment, a group of three lines are scored. The top of the hexagonal rod at the base of the rod handle measures 4 feet from the base of the rod.
- 6.16.2 Place the wading rod in the stream such that the round base sits on the streambed. Read the depth of water on the hexagonal rod. Take care to read depth consistent with the incremental marks on the rod. These markings may or may not be numbered. Make sure to reference the correct foot, half-foot, and tenth-foot marks.
- 6.16.3 Velocity head or pileup will occur to varying degrees depending on water speed. If the pileup on the rod is low a depth reading is somewhat easy and one can estimate depths to the nearest 0.01 foot. In higher velocities pileup and surface bounce will make the depth reading more difficult. Attempt to read the surface by observing the water surface around the rod, and estimate where it intersects the rod. To account for bounce, try to estimate the average between the top and bottom of the bounce. Depending on the severity of these conditions, read the depth to the nearest 0.1 or 0.05 depth.
- 6.16.4 A 3/8-inch diameter round rod sets the position of the current meter to the desired measurement depth of two tenths, six tenths, or eight tenths of total depth at the measurement vertical.

- 6.16.5 The round rod, engraved with numbered lines extending around the circumference of the rod corresponds to the whole foot increment of the measured depth, for example 1.7 feet.
- 6.16.6 On the wading rod handle, the numbers 0 through 10 are pressed with corresponding hash marks. These numbers correspond to the tenths of feet measured in addition to the whole feet, for example 1.7 feet. Set the current meter by aligning the numbered lines corresponding to whole feet of the round rod with the appropriate tenths number pressed into the rod handle.
- 6.16.7 For example, if a depth of 1.7 feet was observed, set the meter at six tenths of depth by aligning the 1 foot line on the round rod with the seven-tenths mark on the rod handle (figure 10). If possible, read the depth to increments less than one tenth of a foot and set the round rod appropriately.



**Figure 10. Wading rod with meter set at six tenths of a depth of 1.7 feet. (Photo by Washington Dept. of Ecology)**

- 6.16.8 Meter settings at two tenths, eight tenths, and six tenths of depth means the meter is positioned in the water column at the respective depth setting measured from the surface of the water. The design of the top setting rod allows users to automatically set the meter at six tenths of depth from the water surface.
- 6.16.9 Described alternatively, setting the meter at six tenths from the water surface also positions it at four tenths of depth from the streambed. This point is important in understanding how to set the rod to measure velocities at two tenths and eight tenths of depth. By dividing the depth by two and setting the meter at that corresponding value, the meter now sits at two tenths depth from the bottom or

eight tenths from the water surface. We refer to the velocity measurement at this depth as an eight-tenths velocity sample.

- 6.16.10 Conversely, if we set the rod at two times the observed depth, the meter positions at eight tenths from the bottom and two tenths from the water surface. We refer to the velocity measurement at this depth as a two tenths velocity sample.

## **7.0 Records Management**

### **7.1 Field Note Forms Archives**

- 7.1.1 We store all original field discharge measurement notes in central locations at Ecology Headquarters, Regional, and Field Offices.

### **7.2 Discharge Records in Hydstra Database**

- 7.2.1 We record all discharge measurement details and store them electronically to the Hydstra Gauging and Sections databases.
- 7.2.2 Measurement details stored in the Gaugings database include the stage, discharge, date and time of the measurement. Other details stored in the Gaugings database include average velocity, area, maximum depth and velocity, width, and wetted perimeter.
- 7.2.3 We store cross-section details, such as vertical locations and bed elevations in the Sections database.

## **8.0 Safety**

- 8.1 We follow all EAP safety policies and consider safety the top priority when conducting stream discharge measurements. Refer to the EAP Safety Manual, (EAP, 2017) for further information about working in and around streams.
- 8.2 In all measurement situations, never attempt unsafe deployments that may result in injury to staff, or damage to equipment.
- 8.3 Always consider the safety and traffic situations when measuring discharge or conducting related work from a bridge. Take appropriate actions including suspending the activity if unsafe conditions exist. Consult the EAP Safety Manual for further guidance regarding bridge measurement safety.
- 8.4 Safely cross the stream in accordance with the guidelines for working in and around streams established in the EAP Safety Manual (EAP, 2017).

## 9.0 References

- 9.1 Buchanan, T.J., and Somers, W.P., 1969. Techniques of Water-Resources Investigations of the United States Geological Survey, Chapter A8, Discharge Measurements At Gaging Stations, Book 3, Applications of Hydraulics. United States Geological Survey, Publication.
- 9.1 Burks, T.W., 2015. Standard Operating Procedure (SOP) for Operation of the Sontek® FlowTracker® Handheld ADV®, Version 1.1. Washington State Department of Ecology, Olympia, WA. SOP Number EAP058. [ecology.wa.gov/About-us/How-we-operate/Scientific-services/Quality-assurance](http://ecology.wa.gov/About-us/How-we-operate/Scientific-services/Quality-assurance)
- 9.3 Environmental Assessment Program, 2017. Environmental Assessment Program Safety Manual, March, 2017. Washington State Department of Ecology, Olympia, WA.
- 9.4 Holt, Z., Shedd, J.R., 2016. Standard Operating Procedure (SOP) for Operation of Mechanical Velocity Indicators, Version 1.2. Washington State Department of Ecology, Olympia, WA. SOP Number EAP 059. [ecology.wa.gov/About-us/How-we-operate/Scientific-services/Quality-assurance](http://ecology.wa.gov/About-us/How-we-operate/Scientific-services/Quality-assurance)
- 9.5 Kennedy, E.J., 1984. Techniques of Water-Resources Investigations of the United States Geological Survey, Chapter A10, Discharge Ratings At Gaging Stations, Book 3, Applications of Hydraulics. United States Geological Survey, Publication.
- 9.5 Rantz, S.E., et al., 1982. Measurement and Computation of Streamflow: Volume 1. Measurement of Stage and Discharge. United States Geological Survey Water-Supply Paper 2175.
- 9.6 Shedd, J.R., Springer, C., Clishe, C.J., 2016. Standard Operating Procedure (SOP) for Operation of the Teledyne RD Instruments® Stream-Pro Acoustic Doppler Current Profiler®, Version 1.2. Washington State Department of Ecology, Olympia, WA. SOP Number EAP055. [ecology.wa.gov/About-us/How-we-operate/Scientific-services/Quality-assurance](http://ecology.wa.gov/About-us/How-we-operate/Scientific-services/Quality-assurance)
- 9.7 Teledyne RD Instruments®. WinRiver Quick Start Guide. 2007. P/N 957-6230-00.



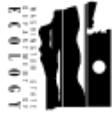

STATE OF WASHINGTON  
DEPARTMENT OF ECOLOGY

**ADCP  
Discharge Measurement Notes**

Mass No. \_\_\_\_\_  
Camp by: \_\_\_\_\_  
Check by: \_\_\_\_\_

Sta. No. \_\_\_\_\_  
Name: \_\_\_\_\_

Date: 20 \_\_\_\_\_ Party: \_\_\_\_\_

Width: \_\_\_\_\_ Area: \_\_\_\_\_ Vel: \_\_\_\_\_ G.H.: \_\_\_\_\_ Disch: \_\_\_\_\_

Method: \_\_\_\_\_ Transsects: \_\_\_\_\_ G.H. change: \_\_\_\_\_ in \_\_\_\_\_ hrs.

Max. Delta Q: \_\_\_\_\_ Max Depth: \_\_\_\_\_ Wetted Perim: \_\_\_\_\_ Meter No.: \_\_\_\_\_

**GAGE READINGS**

Time	PGI	SGI	+/-	Logger	Type of meter
					Qd/x
					Vd/x
					Ad/x

Wading, cable, ice boat, upstr., downstr., side bridge, feet, mile, above, below gage, and: \_\_\_\_\_  
Check-bar, found \_\_\_\_\_ at \_\_\_\_\_ changed to: \_\_\_\_\_ at \_\_\_\_\_

Measurement rated excellent (2%), good (5%), fair (8%), poor (over 8%), based on following conditions:

Cross section: \_\_\_\_\_

Flow: \_\_\_\_\_

Control: \_\_\_\_\_

Gage: \_\_\_\_\_

Weather: \_\_\_\_\_

Other: \_\_\_\_\_

Remarks: \_\_\_\_\_

\_\_\_\_\_

\_\_\_\_\_

\_\_\_\_\_

\_\_\_\_\_

\_\_\_\_\_

Zero flow = GH \_\_\_\_\_ -depth at control \_\_\_\_\_ = \_\_\_\_\_ ft.

ECY 070-938 (09/15)

**Measurement Notes**

Test Ping Transect:  
Right Edge Dist. \_\_\_\_\_  
Left Edge Dist. \_\_\_\_\_  
Max Depth \_\_\_\_\_  
Max Velocity \_\_\_\_\_  
Cell Size \_\_\_\_\_

File Name: \_\_\_\_\_  
Water Mode: \_\_\_\_\_ Profiler depth: \_\_\_\_\_  
Location on SD Card: \_\_\_\_\_  
Moving Bed Test: Yes No \_\_\_\_\_ Ft. in \_\_\_\_\_ Seconds  
No. of Cells \_\_\_\_\_ Deployment \_\_\_\_\_

Transect Number	Start Bank R/L	Start Time PST	Distance to Right Edge	Distance to Left Edge	Discharge	% Delta Q	Width	Area	Velocity
0									
1									
2									
3									
4									
5									
6									
7									
Averages									

## Vehicle and Equipment Checklist

### **Standard Vehicle Equipment:**

*This equipment should be present anytime the vehicle is used.*

- Cell Phone and Charger

### **Vehicle Folder containing**

- Mileage Logs
- Emergency Information
- Fuel Card
- Maps

### **Safety Equipment**

- First Aid Kit
- MUTCD compliant Safety Vests (2)
- CG Approved PFD (1 per person)
- PFD CO<sub>2</sub> Refill
- Road Cones
- Signs
- Hard Hats (2)
- Orange Strobe

### **Tools / Other**

- Mechanic's Toolbox
- Shovel
- Loppers/Clippers/Machete
- Tire Chains
- 2- 150 ft. Ropes
- Spare Key
- Jack, jack handle, adequate spare
- Flashlight
- Lighter
- Electrical Tool Box
- Pens
- Pencils
- Note Paper
- Flagging Tape
- Orange Spray Paint
- Spare Bucket

### **Standard Flow Gear**

#### **Flow Box:**

- Weighted Tape for Tape Down
- Tag Line
- 300 ft. Transect Tape
- Line Clamps
- Swiffer Kit w/ Cables and Fans
- Swiffer Meter
- Bridge Depth Sounding Correction Sheets (2/10, 6/10, 8/10's)
- Survey Pins and Hammer
- Flow Tracker
- Wading rod
- Laser Level
- Stadia Rod

- Thermistor
- Spare Batteries for All Devices
- Battery Chargers
- Discharge Measurement Sheets

### **Station Visit**

- Station Visit Data (PCMCIA, thumb drive, etc.)
- Multi-meter
- Logger Menu Flow Chart
- Desiccant
- Station Key
- USGS key
- Other Keys as needed
- Appropriate DCP Batteries

### **ADCP Gear**

- ADCP Unit
- MobileDemand or Yuma pads
- Tow Ropes and Carabiners
- ADCP Data Sheets

### **Bridge Gear (If Needed)**

- Lead Flow Weights, all sizes
- Bridge Board
- T-bar
- Reel w/ Swiffer Cable

### **3-Wheel Crane**

- Reel
- Crane Assembly

### **4-Wheel Crane**

- HS Meter Box
- Props
- Meter Body w/Fiber-Fin
- Cleaning Soln.
- Lubricant
- Reel
- Crane Assembly/Boom
- Counterweights
- Wheel Chocks

### **Personal Equipment**

- Water
- Food
- Dry Clothes
- Rain Gear
- Sunscreen
- Gloves
- Waders/Hip Boots
- Up to Date Ratings Sheets
- Maps/Station Directions
- Notebook w/ Extra Data Sheets

### **Decontamination Equipment**

- To Be Determined