



DEPARTMENT OF  
**ECOLOGY**  
State of Washington

**Response to Comments**  
**276-BA Organic Storage Area**  
**March 11, 2019 to April 26, 2019**

---

*Summary of a public comment period and responses  
to comments*

May 2019

Publication no. 19-05-006

## Publication and Contact Information

This publication is available on the Department of Ecology's (Ecology) website at <https://fortress.wa.gov/ecy/publications/SummaryPages/1905006.html>

For more information contact:

Stephanie Schleif  
Nuclear Waste Program  
3100 Port of Benton Boulevard  
Richland, WA 99354  
Phone: 509-372-7950  
Email: [Hanford@ecy.wa.gov](mailto:Hanford@ecy.wa.gov)

Washington State Department of Ecology – [www.ecology.wa.gov](http://www.ecology.wa.gov)

- Headquarters, Lacey 360-407-6000
- Northwest Regional Office, Bellevue 425-649-7000
- Southwest Regional Office, Lacey 360-407-6300
- Central Regional Office, Yakima 509-575-2490
- Eastern Regional Office, Spokane 509-329-3400

Ecology publishes this document to meet the requirements of [Washington Administrative Code 173-303-840 \(9\)](#).

*To request ADA accommodation including materials in a format for the visually impaired, call Ecology at 509-372-7950 or visit <https://ecology.wa.gov/accessibility>. People with impaired hearing may call Washington Relay Service at 711. People with speech disability may call TTY at 877-833-6341.*

## **Response to Comments**

---

*276-BA Organic Storage Area*  
*March 11, 2019 to April 26, 2019*

Nuclear Waste Program  
Washington State Department of Ecology  
Richland, Washington

*This page is purposely left blank.*

## **Table of contents**

Introduction.....	1
Reasons for issuing the permit.....	1
Public involvement actions.....	3
List of Commenters.....	4
Attachment 1: Comments and responses	
Appendix A: Copies of all public notices	

## Introduction

The Washington State Department of Ecology's Nuclear Waste Program (Ecology) manages dangerous waste within the state by writing permits to regulate its treatment, storage, and disposal.

When a new permit or a significant modification to an existing permit is proposed, Ecology holds a public comment period to allow the public to review the change and provide formal feedback. (See [Washington Administrative Code \[WAC\] 173-303-830](#) for types of permit changes.)

The Response to Comments is the last step before issuing the final permit, and its purpose is to:

- Specify which provisions, if any, of a permit will become effective upon issuance of the final permit, providing reasons for those changes.
- Describe and document public involvement actions.
- List and respond to all significant comments received during the public comment period and any related public hearings.

### **This Response to Comments is prepared for:**

Comment period: 276-BA Organic Storage Area, March 11, 2019, through April 26, 2019

Permit: *Hanford Facility Resource Conservation and Recovery Act (RCRA) Permit for the Treatment, Storage, and Disposal of Dangerous Waste, Part V, Closure Unit Group 32 (WA7890008967), 276-BA Organic Storage Area*

Permittee(s): U.S. Department of Energy Richland Operations  
CH2M Hill Plateau Remediation Company

To see more information related to the Hanford Site and nuclear waste in Washington, please visit our website: <https://www.ecology.wa.gov/Hanford>.

## Reasons for modifying the permit

The Washington State Department of Ecology (Ecology) is proposing a change to the *Hanford Facility Resource Conservation and Recovery Act (RCRA) Permit, Revision 8c* (Permit). This change incorporates the Dangerous Waste Portion for the Treatment, Storage, and Disposal of Dangerous Waste for the 276-BA Organic Storage Area into the Permit. The 276-BA Organic Storage Area is located in the northeast portion of the B Plant Complex in the 200 East Area of the Hanford Site.

The purpose of the proposed permit modification is to describe clean closure activities that will be completed within 180 days of the start date. Clean closure will eliminate the need for future post-closure inspections, monitoring, and maintenance of the 276-BA Organic Storage Area.

The proposed modification to the Permit will be located in Part V, Closure Unit Group 32. The following is a summary of the proposed additions to Part V of the Permit.

**Permit Conditions:** Ecology drafted unit-specific permit conditions to reflect the dangerous waste permit requirements for closure of the 276-BA Organic Storage Area.

**Addendum H, Closure Plan:** The closure plan proposes clean closure activities for the 276-BA Organic Storage Area. Closure activities include:

- Adding absorbent to stabilize the remaining liquid waste in the container (if found).
- Removing the container, intact, and transporting it to the Environmental Restoration Disposal Facility (ERDF).
- Flood grouting the interior of the container at ERDF prior to final disposal.
- Demolishing, containerizing, and disposing of the secondary containment structure at ERDF.
- Excavating soil beneath the structure up to 3 feet, containerizing the soil, and disposing at ERDF.
- Focused sampling of the site is proposed due to the relatively small size of the secondary containment structure.
- Sampling at locations where concrete joints, the trench, and the sump are located.

## **Public involvement actions**

The Class 3 Permit Modification and first 60-day public comment period on the 276-BA Organic Storage Area was held in 2016 and significant changes were made to the Closure Plan as part of Ecology's completeness determination and technical review.

Ecology held a second 45-day public comment period for the Class 3 Permit Modification from March 11, 2019, through April 26, 2019.

The following actions were taken by Ecology to notify the public:

- Mailed a public notice announcing the comment period to 1282 members of the public.
- Placed a public announcement legal classified advertisement in the *Tri-City Herald* on March 10, 2019.
- Emailed a notice announcing the start of the comment period to the [Hanford-Info email list](#), which has 1357 recipients.

The Hanford information repositories located in Richland, Spokane, and Seattle, Washington and Portland, Oregon received the following documents for public review:

- Focus Sheet
- Transmittal letter
- Response to comments document from the first part of the Class 3 modification
- Draft 276-BA Organic Storage Area Permit Modification documents

The following public notices for this comment period are in [Appendix A](#) of this document:

- Public notice (focus sheet)
- Classified advertisement in the *Tri-City Herald*
- Notice sent to the Hanford-Info email list



## **List of Commenters**

The table below lists the names of organizations or individuals who submitted a comment on the 276-BA Organic Storage Area Permit modification. The comments and responses follow.

<b>Commenter</b>	<b>Organization</b>
Mike Conlan	Citizen

## **Attachment 1: Comments and responses**

## **Letter I-1: Mike Conlan, 3/21/19 6:34 PM PT**

### **Comment I-1-1**

- 1. Remove all nuclear waste,*
- 2. Do not allow anymore nuclear waste into the facility,*
- 3. Replace all the single storage tanks,*
- 4. Stop all the nuclear leakage entering the Columbia River*

### **Ecology Response to I-1-1**

Ecology is working to ensure that long-term storage, treatment and disposal of the waste is protective of human health and the environment. The proposed permit changes are not to allow new waste, but to better manage the waste already at Hanford. Single-shell tanks are not in the scope of this comment period. Ecology does agree the tanks pose a threat. We believe a better approach to addressing it is to remove the waste from the single-shell tanks and put it in the compliant double-shell tanks to prepare for eventual treatment in the Waste Treatment Plant now being built. The permit modification proposes clean closure for the 276-BA Organic Storage Area. Clean closure will eliminate the need for future post-closure inspections, monitoring, and maintenance.

## **Appendix A: Copies of all public notices**

Public notices for this comment period:

- Public notice (focus sheet)
- Classified advertisement in the *Tri-City Herald*
- Notice sent to the Hanford-Info email list

# 276-BA Organic Storage Area Permit Modification



## Public comment period

March 11 – April 26, 2019

Please submit comments

Electronically (preferred) via:

<http://wt.ecology.commentinput.com/?id=YPUpu>

By U.S. Mail, or hand-delivery:

Daina McFadden  
3100 Port of Benton Blvd  
Richland WA 99354

## Public hearing

A public hearing is not scheduled, but if there is enough interest, we will consider holding one. To request a hearing or for more information, contact:

Daina McFadden  
509-372-7950  
[Hanford@ecy.wa.gov](mailto:Hanford@ecy.wa.gov)

## Special accommodations

To request ADA accommodation including materials in a format for the visually impaired, call Ecology at 509-372-7950 or visit <https://ecology.wa.gov/accessibility>. People with impaired hearing may call Washington Relay Service at 711. People with speech disability may call TTY at 877-833-6341.

## Public comment invited

The Washington State Department of Ecology (Ecology) is proposing a change to the Hanford Facility Resource Conservation and Recovery Act (RCRA) Permit, Revision 8c (Permit). This change incorporates into the Permit, the Dangerous Waste Portion for the Treatment, Storage, and Disposal of Dangerous Waste for the 276-BA Organic Storage Area. The 276-BA Organic Storage Area is located in the northeast portion of the B Plant Complex in the 200 East Area of the Hanford Site. The proposed modification to the Permit will be located in Part V, Closure Unit Group 32.

The permittees are:

U.S. Department of Energy Richland Operations (USDOE)  
P.O. Box 550  
Richland, Washington 99352

CH2M Hill Plateau Remediation Company  
P.O. Box 1600  
Richland, Washington 99354

Ecology invites you to review and comment on this proposed permit modification. The comment period begins March 11, 2019, and ends April 26, 2019.

The class 3 permit modification will include the following:

- Permit Conditions
- Addendum H, Closure Plan which proposes clean closure activities that will be completed within 180 days of the start date. The diagram on page 3 provides a schematic of the ISO-East Container. USDOE initiated a Class 3 permit modification to add the 276-BA Organic Storage Area to the Permit on May 4, 2016. The 60 day public comment period as required by Washington Administrative Code (WAC) 173-303-830(4)(c) began on April 25, 2016, and ended on August 6, 2016.

Ecology issued a Letter of Incompleteness and Notice of Deficiency for the Class 3 Permit Modification Request on August 11, 2016. We resolved the deficiencies with the permittees and the permit modification was determined to be complete. Ecology responded to one public comment submitted during that comment period. Changes to the closure plan include the following:

- The 276-BA container was previously classified as a tank in the B Plant Complex Part A Form concerning the B Plant Organic Mixed Waste Storage System. Upon further review, USDOE determined that 276-BA ISO East should be classified as a container because it meets the RCRA definition of a container in WAC-173-303-040. 276-BA ISO East will be closed under the container standards in WAC 173-303-630(10).
- In addition, the components of the United States Environmental Protection Agency 7 Step Data Quality Objectives were evaluated and identified in the Closure Plan for 276-BA Organic Storage Area.

## Background

The 276-BA Organic Storage Area is located in a secure fenced area in the northeast portion of the B Plant Complex in the 200 East Area of the Hanford Site.



Historically, the 276-BA Organic Storage Area was part of the Organic Mixed Waste Storage System, which was used for chemical processing and to store organic chemicals used in the recovery and purification of strontium.

The 276-BA Organic Storage Area consists of a single storage container (ISO East) and secondary containment structure. The secondary containment structure has two separate compartments. The west compartment is empty and was never used for dangerous waste storage or treatment.

The east compartment contains the ISO East Container. This container, which received waste directly from the B Plant Complex, was placed in the 276-BA Organic Storage Area secondary containment structure, sealed and intact. The stored wastes were then removed from the ISO East container to a tanker truck for offsite disposal in 1997. Any potential releases from the ISO East container would likely be found in the location of the sump or trench within the ISO East portion of the secondary containment structure. These areas have been identified for soil sampling to demonstrate clean closure.

The ISO-East container currently contains less than two gallons of washed organic residues consisting of normal paraffin hydrocarbons (NPH), di-(2-ethylhexyl) phosphoric acid (D2EHPA), tributyl phosphate (TBP), and small amounts of strontium-89/90 and cesium-137.

## Why cleanup matters

Ecology would like your comments on the proposed draft language that describes clean closure in the closure plan. Clean closure will eliminate the need for future post-closure inspections, monitoring, and maintenance, and will include the following:

- Adding absorbent to stabilize the remaining liquid waste in the container (if found).
- Removing the container, intact, and transporting it to the Environmental Restoration Disposal Facility (ERDF).
- Flood grouting the interior of the container at ERDF prior to final disposal.
- Demolishing, containerizing, and disposing of the secondary containment structure at ERDF.
- Excavating soil beneath the structure up to 3 feet, containerizing, and disposing at ERDF.
- Focused sampling of the site is proposed due to the relatively small size of the secondary containment structure.
- Sampling will be at locations where concrete joints, the trench, and the sump are located.



Figure 2 - 276-BA Organic Storage Area including the ISO-East container

## View the full proposal

Ecology invites to you to review and comment on this proposed permit modification. This Focus Sheet is a summary of the proposed changes. See [page 1](#) for comment period dates and information on how to submit comments. Copies of the proposed modification are available at the Administrative Record and Information Repositories listed on [page 4](#). In addition, the proposed modification is online at <https://ecology.wa.gov/Waste-Toxics/Nuclear-waste/Public-comment-periods>.

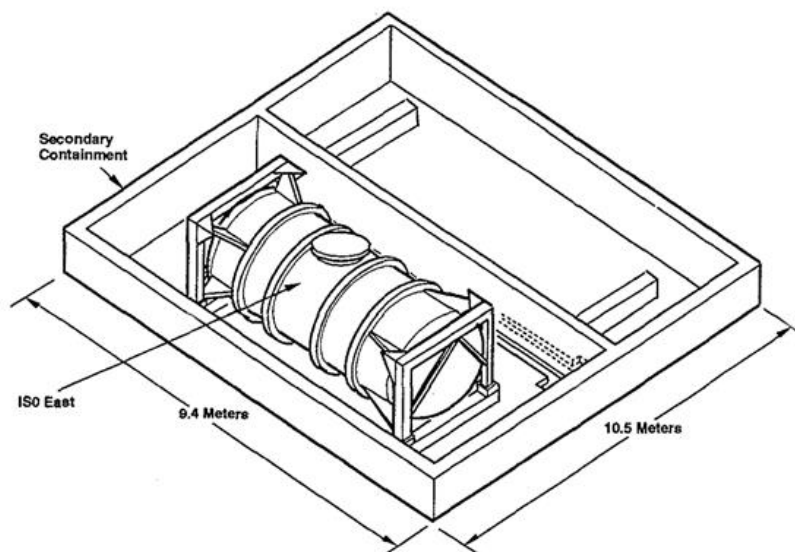

Figure 3 - A schematic of the ISO-East Container

Ecology will consider and respond to all comments received during the public comment period. We will make the final permitting decision after the close of the comment period. We will publish a Response to Comments document with the issuance of the final permit.



DEPARTMENT OF  
**ECOLOGY**  
State of Washington

Nuclear Waste Program  
3100 Port of Benton Blvd  
Richland, WA 99354

### Hanford's Information Repositories and Document Review Locations

#### Washington

##### **Richland**

Ecology Nuclear Waste Program  
Resource Center  
3100 Port of Benton Blvd.  
Richland, WA 99354  
509-372-7950

U.S. Department of Energy  
Administrative Record  
2440 Stevens Drive, Room 1101  
Richland, WA 99354  
509-376-2530

Washington State University Tri-Cities  
Department of Energy Reading Room  
2770 Crimson Way, Room 101L  
Richland, WA 99354  
509-375-7443

#### **Seattle**

University of Washington Suzzallo Library  
P.O. Box 352900  
Seattle, WA 98195  
206-543-5597

#### **Spokane**

Gonzaga University  
Foley Center  
502 E Boone Avenue  
Spokane, WA 99258  
509-313-6110

#### **Oregon**

##### **Portland**

Portland State University  
Millar Library  
1875 SW Park Avenue  
Portland, OR 97207  
503-725-4542



## Legals

### Legal & Public Notices

#### 276-BA Organic Storage Area Permit Modification

Public comment invited  
The Washington State Department of Ecology (Ecology) is proposing a change to the Hanford Facility Resource Conservation and Recovery Act (RCRA) Permit, Revision 8c (Permit). This change incorporates into the Permit, the Dangerous Waste Portion for the Treatment, Storage, and Disposal of Dangerous Waste for the 276-BA Organic Storage Area. The 276-BA Organic Storage Area is located in the northeast portion of the B Plant Complex in the 200 East Area of the Hanford Site. The proposed modification to the Permit will be located in Part V, Closure Unit Group 32.

The permittees are:  
U.S. Department of Energy Richland Operations (USDOE), P.O. Box 550, Richland, Washington 99352  
CH2M Hill Plateau Remediation Company, P.O. Box 1600, Richland, Washington 99354

Ecology invites you to review and comment on this proposed permit modification. The comment period begins March 11, 2019, and ends April 26, 2019. The class 3 permit modification will include the following:

- Permit Conditions
- Addendum H, Closure Plan which proposes clean closure activities that will be completed within 180 days of the start date.

USDOE initiated a Class 3 permit modification to add the 276-BA Organic Storage Area to the Permit on May 4, 2016. The 60 day public comment period as required by Washington Administrative Code (WAC) 173-303-830(4)(c) began on April 25, 2016, and ended on August 6, 2016. Ecology issued a Letter of Incompleteness and Notice of Deficiency for the Class 3 Permit Modification Request on August 11, 2016. We resolved the deficiencies with the permittees and the permit modification was determined to be complete. Ecology responded to one public comment submitted during that comment period. Changes to the closure plan include the following:

- The 276-BA container was previously classified as a tank in the B Plant Complex Part A Form concerning the B Plant Organic Mixed Waste Storage System. Upon further review, USDOE determined that 276-BA ISO East should be classified as a container because it meets the RCRA definition of a container. In WAC 173-303-040, 276-BA ISO East will be closed under the container standards in WAC 173-303-630(10).

- In addition, the components of the United States Environmental Protection Agency 7 Step Data Quality Objectives were evaluated and identified in the Closure Plan for 276-BA Organic Storage Area.

**Background**  
The 276-BA Organic Storage Area is located in a secure fenced area in the northeast portion of the B Plant Complex in the 200 East Area of the Hanford Site. Historically, the 276-BA Organic Storage Area was part of the Organic Mixed Waste Storage System, which was used for chemical processing and to store organic chemicals used in the recovery and purification of strontium. The 276-BA Organic Storage Area consists of a single storage container (ISO East) and secondary containment structure. The secondary containment structure has two separate compartments. The west compartment is empty and was never used for dangerous waste storage or treatment. The east compartment contains the ISO East Container. This container, which received waste directly from the B Plant Complex, was placed in the 276-BA Organic Storage Area secondary containment structure, sealed and intact. The stored wastes were then removed from the ISO East container to a tanker truck for offsite disposal in 1997. Any potential releases from the ISO East container would likely be found in the location of the sump or trench within the ISO East portion of the secondary containment structure. These areas have been identified for soil sampling to demonstrate clean closure. The ISO-East container currently contains less than two gallons of washed organic residues consisting of normal paraffin hydrocarbons (NPH), di-(2-ethylhexyl) phosphoric acid (D2EHPA), tributyl phosphate (TBP), and small amounts of strontium-89/90 and cesium-137.

#### Why cleanup matters

Ecology would like your comments on the proposed draft language that describes clean closure in the closure plan. Clean closure will eliminate the need for future post-closure inspections, monitoring, and maintenance, and will include the following:

- Adding absorbent to stabilize the remaining liquid waste in the container (if found).
- Removing the container, intact, and transporting it to the Environmental Restoration Disposal Facility (ERDF).
- Flood grouting the interior of the container at ERDF prior to final disposal.
- Demolishing, containerizing, and disposing of the secondary containment structure at ERDF.
- Excavating soil beneath the structure up to 3 feet, containerizing, and disposing at ERDF.
- Focused sampling of the site is proposed due to the relatively small size of the secondary containment structure.
- Sampling will be at locations where concrete joints, the trench, and the sump are located.

View the full proposal.  
Ecology invites you to review and comment on this proposed permit modification. This Focus Sheet is a summary of the proposed changes. See below for comment period dates and information on how to submit comments. Copies of the proposed modification are available at the Administrative Re-

Richland, WA 99354  
509-375-7443  
Seattle  
University of Washington Suzzallo Library  
P.O. Box 352900  
Seattle, WA 98195  
206-543-5597  
Spokane  
Gonzaga University  
Foley Center  
502 E Boone Avenue  
Spokane, WA 99258  
509-343-6110  
Oregon  
Portland  
Portland State University  
Miller Library  
1875 SW Park Avenue  
Portland, OR 97207  
503-725-4542

### CALL FOR BIDS

NOTICE IS HEREBY GIVEN that Public Utility District No. 1 of Franklin County will receive sealed bids no later than 3:00 p.m., Tuesday, April 2, 2019 at the offices of the District at 1411 West Clark Street, Pasco, Washington 99301. Bid is for furnishing and delivering two (2) fleet pick-ups, as per specifications, which may be obtained from the office of the District in Pasco, Washington.

Bid prices shall be firm for a minimum of sixty (60) days from the date of the bid opening. All bid prices shall include State and local sales taxes and use taxes.

All bids shall be sealed and shall be marked:

#### 'Bid Document 9391 - Purchase of Two (2) Fleet Pick-Ups'

Bids will be publicly opened in the District office at 1411 West Clark Street, Pasco, Washington, on Tuesday, April 2, 2019, at 3:00 p.m. The District reserves the right to reject any or all bids and to waive informalities that may arise during the bidding process.

Each bid shall be accompanied by a certified or cashier's check payable to the order of the Commissioners of Public Utility District No. 1 of Franklin County, for a sum not less than five percent (5%) of the amount of the bid or accompanied by a bid bond in an amount not less than five percent (5%) of the bid with a corporate surety licensed to do business in the State of Washington. This Call for Bids is in conformity with RCW 54.04.070 and 54.04.080 and such statutes are incorporated into this Call for Bids.

#### PUBLIC UTILITY DISTRICT NO. 1 OF FRANKLIN COUNTY

By: /s/ Rebecca Diaz  
Rebecca Diaz  
Contract Administrator

**CITY OF PASCO**  
NOTICE OF SPECIAL MEETING  
PLEASE TAKE NOTICE that the City Council of the City of Pasco, Washington, will hold a Special Meeting on Wednesday, March 13th at 6:00 p.m., in the City Council Chambers at 525 N. 3rd Avenue. The purpose of the meeting is to hear presentation from a delegation from Colima, Mexico as part of consideration prior to the City entering into a formal Cooperation Agreement (Sister City) relationship.  
City Clerk

#### CITY OF RICHLAND, WASHINGTON

#### CALL FOR BIDS CONTRACT: 19-0025

#### HORN RAPIDS LANDFILL DISPOSAL CAPACITY IMPROVEMENTS - PHASE 1A EARTHWORK PROJECT BIDS DUE: MARCH 19, 2019 2 PM PST

Public notice is hereby given that sealed bids will be received for the City of Richland's HORN RAPIDS LANDFILL DISPOSAL CAPACITY IMPROVEMENTS - PHASE 1A EARTHWORK PROJECT by the City of Richland Purchasing Division at 2700 Dupontall, bldg. 100, until the date and time specified above, at which time bids will be opened and read publicly. This project provides for excavation and embankment construction of the Horn Rapids Landfill Disposal Capacity Improvements - Phase 1A Earthwork to the east of the existing landfill and northeast of the entrance to the landfill. The project area is approximately 18 acres. Generally, this requires over 500,000 cy of excavation and 38,000 cy of embankment, grading, and compacting subgrade for the future landfill and leachate pond. Major portion of the excavation completed. However, the Contractor will be required to place and compact additional embankment in the excavated area in accordance with the Plans. Full notice and complete details of the solicitation are available from [www.PublicPurchase.com](http://www.PublicPurchase.com). Interested contractors must first register with Public Purchase. There is no charge to register, receive notifications or view and download the documents. Visit the City of Richland website at [www.ci.richland.wa.us](http://www.ci.richland.wa.us) under Departments/Administrative Services/Purchasing/Public Purchase for information on how to register.

The City of Richland in accordance with Title VI of the Civil Rights Act of 1964, 78 Stat. 252, 42 U.S.C. 2000d-4 and Title 49, Code of Federal Regulations, Department of Transportation, subtitle A, Office of the Secretary, Part 21, nondiscrimination in federally assisted programs of the Department of Transportation issued pursuant to such Act, hereby notifies all bidders that it will affirmatively insure that in any contract entered into pursuant to this advertisement, disadvantaged business enterprises as defined at 49 CFR Part 26 will be afforded full opportunity to submit bids in response to this invitation and will not be discriminated against on the grounds of race, color

#### CITY OF WEST RICHLAND

#### MUNICIPAL SERVICE FACILITY FINANCE

You are invited to bid on a Municipal Services Facility Finance TI project for the City of West Richland located at 3100 Belmont Blvd., West Richland, WA.

This project consists of completing the tenant improvements of the finance portion of the Municipal Services Facility and all related items in accordance with the technical specifications, drawings, and contract documents.

The City of West Richland will receive sealed bids for the MUNICIPAL SERVICES FACILITY FINANCE TI, at the City of West Richland Municipal Services Facility, 3100 Belmont Blvd., Suite 102 West Richland, Washington 99353 until 2:00 p.m., Tuesday, March 26, 2019.

All bid proposals shall be accompanied by a bid proposal deposit in cash, certified check, cashier's check, or surety bond in an amount equal to five percent (5%) of the amount of such bid proposal. Should the successful Bidder fail to enter into such contract and furnish satisfactory performance bond or quality assurance submittals within the time stated in the contract documents, the bid proposal deposit shall be forfeited to the City of West Richland. Each Bidder shall warrant that he has not entered into collusion with another bidder or any other person, and does not discriminate in any manner against any person based solely on race, color, sex, or creed.

Upon request each firm, company, and/or corporation shall receive, at no cost, a PDF copy of all contract documents, specifications and plans by contacting the Public Works Department of the City of West Richland by either email: [ilka@westrichland.org](mailto:ilka@westrichland.org), phone: (509) 967-5434, or by mail: 3100 Belmont Blvd., Suite 102, West Richland, Washington.

Only properly executed proposals submitted on the forms furnished by the City of West Richland will be accepted. The City of West Richland reserves the right to reject any or all bids, to waive any informalities, to accept any bid deemed to be responsive in the best interest of the City of West Richland and reserves the right to readvertise for new proposals.

The City of West Richland is an Equal Opportunity Employer. Minority and women-owned businesses are encouraged to bid.  
Roscoe C Slade, Director of Public Works

#### DEVELOPMENT SERVICES RFP NOTICE

NOTICE is hereby given that a Request for Proposals for Development Services has been released by the Housing Authority City of Kennewick, 1915 W. 4th Place, Kennewick, Washington 99336. Due date: Monday, April 22, 2019, 5:30 pm. The RFP is posted on the KHA website at [www.kennewickha.org](http://www.kennewickha.org). Prospective proposers can secure a copy from L. Hammer or H. Sierra at KHA. MBE/WBE businesses and businesses who hire Section 3-eligible staff are encouraged to apply. KHA is an Equal Opportunity Agency.

#### INVITATION FOR BIDS

##### AMON PUMP STATION PIPING (MATERIALS ONLY)

The Kennewick Irrigation District (KID) is inviting and requesting bid proposals for the furnishing of materials only for the Amon Pump Station Piping (Materials Only) project, related but not limited to, pipe, valves, fittings, and other appurtenant water work supplies. The materials include approximately 365,000 linear feet of 16-inch and 12-inch pipe, and other related water work supplies. Included in the project is the delivery of all the materials to the project site at the Amon Pump Station, located near the intersection between Bob Olson Parkway and Wheat Rd. in Kennewick, WA.

Bid documents, including a material list and specifications are available at the Kennewick Irrigation District, 2015 S. Ely Street, Kennewick WA, 99337 starting at 3:00 p.m. Tuesday, March 12, 2019.

Bids shall be titled, "Amon Pump Station Piping (Materials Only)" and shall be addressed to the Kennewick Irrigation District Board of Directors. Bids will be received by Lori Gibson, Executive Assistant, 2015 S. Ely Street, Kennewick, WA 99337, up to 10:00 a.m., on Monday, March 25, 2019, at which time they will be publicly opened and read aloud at the Kennewick Irrigation District Office. Bids are to be submitted only on original forms provided in the specifications. Following receipt of a successful bid, award of the contract will proceed the week of the bid.

Technical questions regarding the scope of this project should be directed in writing, using the Request for Information form located in the appendices of the contract documents via fax at (509) 586-7663 or by calling Daniel Tisell, KID Engineer at (509) 586-6012 ext. 116.

The KID reserves the right to reject any or all bids, to waive technicalities, to combine this contract with other contracts when considering contract award, and to accept any bid which it deems in the best interest of the District.

The KID hereby notifies all bidders that it encourages and will affirmatively ensure that in any contract entered into, pursuant to this invitation, certified minority and women's business enterprises will be afforded full opportunity to submit

track storage building, shade structure, and asphalt and concrete paving at Horse Heaven Hills Middle School. Specifics regarding the project include building construction, track and field with surfacing and equipment, site lighting, electrical, landscaping, irrigation, selective demolition, concrete work, fencing, underground drainage, gravel, and asphalt paving. The Owner hereby notifies all bidders that it will affirmatively ensure that in any contract entered into pursuant to this advertisement, minority business enterprises will be afforded full opportunities to submit bids and will not be discriminated against on the grounds of race, color, sex, handicap, or national origin in consideration for an award. This project is subject to the Benton County prevailing wage rate requirements.

The contract documents are available and will be posted on the Knutzen Engineering Share-File web site at <https://knutzenengineering.sharefile.com/1/d54335201a34784a>

then enter your email address, name, and company name to gain access to all the bid documents. Registered users on the ShareFile site will receive notifications when any new addendums (if applicable) are posted to the site. Contractor shall be required to obtain all required addendums prior to bidding and shall include in their bid. Each bid shall be accompanied by a certified check, cashier's check, bank draft, or money order payable to the Owner or a bid bond with a corporate surety licensed to do business in the State of Washington, in an amount not less than five (5) percent of the amount of the bid. The successful bidder for this project will be required to submit a payment and performance bond upon award of the contract.

**ORDINANCE NO. 14-19 AN ORDINANCE** of the City of Richland amending Title 23: Zoning Regulations of the Richland Municipal Code and the Official Zoning Map of the City to change the zoning on 1.07 acres from Neighborhood Retail (C-1) to Commercial Limited Business (C-LB); said property being located at 1019 Wright Avenue, and adopting the findings and conclusions of the Hearing Examiner as the findings and conclusions of the Richland City Council. Ordinance effective the day following its publication. Ordinance available at the City Clerk's Office, 975 George Washington Way, Richland, WA 99352 or (509) 942-7388

**ORDINANCE NO. 15-19 AN ORDINANCE** of the City of Richland amending the 2019-2024 Capital Improvement Plan and 2019 Budget to provide for additional appropriations in the City's Streets Capital Construction Fund, City Streets Fund, Capital Improvements Fund and Industrial Development Fund and declaring that a public emergency exists in the Capital Improvements Fund and Industrial Development Fund. Ordinance effective the day following its publication. Ordinance available at the City Clerk's Office, 975 George Washington Way, Richland, WA 99352 or (509) 942-7388.

**ORDINANCE NO. 16-19 AN ORDINANCE** of the City of Richland amending the 2019 Budget and 2019-2024 Capital Improvement Plan to provide for additional appropriations and declaring that a public emergency exists in the City's Equipment Replacement Fund. Ordinance effective the day following its publication. Ordinance available at the City Clerk's Office, 975 George Washington Way, Richland, WA 99352 or (509) 942-7388.

**ORDINANCE NO. 17-19 AN ORDINANCE** of the City of Richland amending Chapter 2.18 of the Richland Municipal Code related to the Parks and Recreation Commission. Ordinance available at the City Clerk's Office, 975 George Washington Way, Richland, WA 99352 or (509) 942-7388.

#### Reclamation Announces Negotiations with the East Columbia Basin Irrigation District for Amendment of Renewal Master Water Service Contract

The Bureau of Reclamation invites interested members of the public to observe a working session with the East Columbia Basin Irrigation District (District). The purpose of this session will be for Reclamation and the District to arrive at mutually agreeable terms and conditions for a proposed amendment to Renewal Master Water Service Contract No. 159E101882 that would, among other things, authorize the District to provide Columbia Basin Project irrigation water as groundwater replacement irrigation water service to additional irrigable lands located within the Odessa Subarea and within the service area of the District.

The contract amendment will reflect existing Federal Reclamation law and policy governing water service contracts. The goal of the negotiations is to arrive at a mutually agreeable contract. The negotiation session will be held:

March 21, 2019 at 10:00 a.m.  
Wingate by Wyndham, Spokane Airport  
2726 S. Flint Road  
Spokane, WA 99224

Only persons authorized to act on behalf of the contracting parties may negotiate the terms and conditions of the contract amendment which is the subject of this negotiation session. However, interested parties are welcome to attend and will have the opportunity to provide comments regarding this contracting action. The negotiators do not plan to respond at the session to comments from observers.

Copies of the latest draft of proposed contract amendment will be available at the session. For additional information regarding this notice, please contact: Amy Rodman, Bureau of Reclamation, Ephrata Field Office, at (509) 754-0238, or Michael Cobell, Regional Of-

East will be closed under the container standards in WAC 173-303-630(10).

In addition, the components of the United States Environmental Protection Agency 7 Step Data Quality Objectives were evaluated and identified in the Closure Plan for 276-BA Organic Storage Area.

**Background**  
The 276-BA Organic Storage Area is located in a secure fenced area in the northeast portion of the B Plant Complex in the 200 East Area of the Hanford Site. Historically, the 276-BA Organic Storage Area was part of the Organic Mixed Waste Storage System, which was used for chemical processing and to store organic chemicals used in the recovery and purification of strontium. The 276-BA Organic Storage Area consists of a single storage container (ISO East) and secondary containment structure. The secondary containment structure has two separate compartments. The west compartment is empty and was never used for dangerous waste storage or treatment. The east compartment contains the ISO East Container. This container, which received waste directly from the B Plant Complex, was placed in the 276-BA Organic Storage Area secondary containment structure, sealed and intact. The stored wastes were then removed from the ISO East container to a tanker truck for offsite disposal in 1997. Any potential releases from the ISO East container would likely be found in the location of the sump or trench within the ISO East portion of the secondary containment structure. These areas have been identified for soil sampling to demonstrate clean closure. The ISO-East container currently contains less than two gallons of washed organic residues consisting of normal paraffin hydrocarbons (NPH), di-(2-ethylhexyl) phosphoric acid (D2EHPA), tributyl phosphate (TBP), and small amounts of strontium-89/90 and cesium-137.

**Why cleanup matters**  
Ecology would like your comments on the proposed draft language that describes clean closure in the closure plan. Clean closure will eliminate the need for future post-closure inspections, monitoring, and maintenance, and will include the following:

- Adding absorbent to stabilize the remaining liquid waste in the container (if found).
- Removing the container, intact, and transporting it to the Environmental Restoration Disposal Facility (ERDF).
- Flood grouting the interior of the container at ERDF prior to final disposal.
- Demolishing, containerizing, and disposing of the secondary containment structure at ERDF.
- Excavating soil beneath the structure up to 3 feet, containerizing, and disposing at ERDF.
- Focused sampling of the site is proposed due to the relatively small size of the secondary containment structure.
- Sampling will be at locations where concrete joints, the trench, and the sump are located.

**View the full proposal**  
Ecology invites you to review and comment on this proposed permit modification. This Focus Sheet is a summary of the proposed changes. See below for comment period dates and information on how to submit comments. Copies of the proposed modification are available at the Administrative Record and Information Repositories listed below. In addition, the proposed modification is online at <https://ecology.wa.gov/Waste-Toxics/Nuclear-waste/Public-comment-periods>.

Ecology will consider and respond to all comments received during the public comment period. We will make the final permitting decision after the close of the comment period. We will publish a Response to Comments document.

**Public comment period**  
March 11 – April 26, 2019  
Please submit comments electronically (preferred) via: <http://wte.ecology.wa.gov/commentinput.com/?id=YPJup>

By U.S. Mail, or hand-delivery: Daina McFadden, 3100 Port of Benton Blvd, Richland WA 99354  
Public hearing

A public hearing is not scheduled but if there is enough interest, we will consider holding one. To request a hearing or for more information, contact Daina McFadden, 509-372-7950, Hanford@ecy.wa.gov

**Special accommodations**  
To request ADA accommodation including materials in a format for the visually impaired, call Ecology at 509-372-7950 or visit <https://ecology.wa.gov/accessibility>. People with impaired hearing may call Washington Relay Service at 711. People with speech disability may call TTY at 877-833-6341.

Hanford's Information Repositories and Document Review Locations  
Washington  
Richland

Ecology Nuclear Waste Program Resource Center  
3100 Port of Benton Blvd.  
Richland, WA 99354  
509-372-7950

U.S. Department of Energy Administrative Record  
2440 Stevens Drive, Room 1101  
Richland, WA 99354  
509-376-2530

Washington State University Tri-Cities Department of Energy Reading Room  
2770 Crimson Way, Room 101L

This Call for Bids is in conformity with RCW 54.04.070 and 54.04.080 and such statutes are incorporated into this Call for Bids.

#### PUBLIC UTILITY DISTRICT NO. 1 OF FRANKLIN COUNTY

By: /s/ Rebecca Diaz  
Rebecca Diaz  
Contract Administrator

#### CITY OF PASCO NOTICE OF SPECIAL MEETING

PLEASE TAKE NOTICE that the City Council of the City of Pasco, Washington, will hold a Special Meeting on Wednesday, March 13th at 6:00 p.m., in the City Council Chambers at 525 N. 3rd Avenue. The purpose of the meeting is to hear presentation from a delegation from Colima, Mexico as part of consideration prior to the City entering into a formal Cooperation Agreement (Sister City) relationship.  
City Clerk

#### CITY OF RICHLAND, WASHINGTON CALL FOR BIDS CONTRACT: 19-0025 HORN RAPIDS LANDFILL DISPOSAL CAPACITY IMPROVEMENTS – PHASE 1A EARTHWORK PROJECT BIDS DUE: MARCH 19, 2019 2 PM PST

Public notice is hereby given that sealed bids will be received for the City of Richland's HORN RAPIDS LANDFILL DISPOSAL CAPACITY IMPROVEMENTS – PHASE 1A EARTHWORK PROJECT by the City of Richland Purchasing Division at 2700 Duportail, bldg. 100, until the date and time specified above, at which time bids will be opened and read publicly. This project provides for excavation and embankment construction of the Horn Rapids Landfill Disposal Capacity Improvements - Phase 1A Earthwork to the east of the existing landfill and northeast of the entrance to the landfill. The project area is approximately 18 acres. Generally, this requires over 500,000 cy of excavation and 38,000 cy of embankment, grading, and compacting subgrade for the future landfill and leachate pond.

Major portion of the excavation completed. However, the Contractor will be required to place and compact additional embankment in the excavated area in accordance with the Plans. Full notice and complete details of the solicitation are available from [www.PublicPurchase.com](http://www.PublicPurchase.com). Interested contractors must first register with Public Purchase. There is no charge to register, receive notifications or view and download the documents. Visit the City of Richland website at [www.ci.richland.wa.us](http://www.ci.richland.wa.us) under Departments/Administrative Services/Purchasing/Public Purchase for information on how to register.

The City of Richland in accordance with Title VI of the Civil Rights Act of 1964, 78 Stat. 252, 42 U.S.C. 2000d to 2000d-4 and Title 49, Code of Federal Regulations, Department of Transportation, subtitle A, Office of the Secretary, Part 21, nondiscrimination in federally assisted programs of the Department of Transportation issued pursuant to such Act, hereby notifies all bidders that it will affirmatively insure that in any contract entered into pursuant to this advertisement, disadvantaged business enterprises as defined at 49 CFR Part 26 will be afforded full opportunity to submit bids in response to this invitation and will not be discriminated against on the grounds of race, color, national origin, or sex in consideration for an award.

#### CITY OF RICHLAND, WASHINGTON CALL FOR BIDS CONTRACT: 19-0027 2019 ASPHALT RUBBERIZED CHIP SEAL BIDS DUE: MARCH 19, 2019, 2:30 P.M.

Public notice is hereby given that sealed bids will be received for the City of Richland's 2019 Asphalt Rubberized Chip Seal Project by the City of Richland Purchasing Division at 2700 Duportail, bldg. 100, until the date and time specified above, at which time bids will be opened and read publicly. This project provides for the construction of 3/8 Inch Asphalt Rubberized Chip Seal, Type IV (63,500 square yards); traffic control, pavement marking removal, temporary and permanent pavement marking, and crack sealing. Full notice and complete details of the solicitation are available from [www.PublicPurchase.com](http://www.PublicPurchase.com). Interested contractors must first register with Public Purchase. There is no charge to register, receive notifications or view and download the documents. Visit the City of Richland website at [www.ci.richland.wa.us](http://www.ci.richland.wa.us) under Departments/Administrative Services/Purchasing/Public Purchase for information on how to register.

The City of Richland in accordance with Title VI of the Civil Rights Act of 1964, 78 Stat. 252, 42 U.S.C. 2000d to 2000d-4 and Title 49, Code of Federal Regulations, Department of Transportation, subtitle A, Office of the Secretary, Part 21, nondiscrimination in federally assisted programs of the Department of Transportation issued pursuant to such Act, hereby notifies all bidders that it will affirmatively insure that in any contract entered into pursuant to this advertisement, disadvantaged business enterprises as defined at 49 CFR Part 26 will be afforded full opportunity to submit bids in response to this invitation and will not be discriminated against on the grounds of race, color, national origin, or sex in consideration for an award.

#### DEVELOPMENT SERVICES RFP NOTICE

NOTICE is hereby given that a Request for Proposals for Development Services has been released by the Housing Authority City of Kennewick, 1915 W. 4th Place, Kennewick, Washington 99336. Due date: Monday, April 22, 2019, 5:30 pm. The RFP is posted on the KHA website at [www.kennewickha.org](http://www.kennewickha.org). Prospective proposers can secure a copy from L. Hammer or H. Sierra at KHA. MBE/WBE businesses and businesses who hire Section 3-eligible staff are encouraged to apply. KHA is an Equal Opportunity Agency.

#### INVITATION FOR BIDS

#### AMON PUMP STATION PIPING (MATERIALS ONLY)

The Kennewick Irrigation District (KID) is inviting and requesting bid proposals for the furnishing of materials only for the Amon Pump Station piping (Materials Only) project, related but not limited to, pipe, valves, fittings, and other appurtenant water work supplies. The materials include approximately 365 total linear feet of 16-inch and 12-inch pipe, and other related water work supplies. Included in the project is the delivery of all the materials to the project site at the Amon Pump Station, located near the intersection between Bob Olson Parkway and Wheat Rd. in Kennewick, WA.

Bid documents, including a material list and specifications are available at the Kennewick Irrigation District, 2015 S. Ely Street, Kennewick WA, 99337 starting at 3:00 p.m. Tuesday, March 12, 2019.

Bids shall be titled, "Amon Pump Station Piping (Materials Only)" and shall be addressed to the Kennewick Irrigation District Board of Directors. Bids will be received by Lori Gibson, Executive Assistant, 2015 S. Ely Street, Kennewick, WA 99337, up to 10:00 a.m., on Monday, March 25, 2019, at which time they will be publically opened and read aloud at the Kennewick Irrigation District Office. Bids are to be submitted only on original forms provided in the specifications. Following receipt of a successful bid, award of the contract will proceed the week of the bid.

Technical questions regarding the scope of this project should be directed in writing, using the Request for Information form located in the appendices of the contract documents via fax at (509) 586-7663 or by calling Daniel Tissel, KID Engineer at (509) 586-6012 ext. 118.

The KID reserves the right to reject any or all bids, to waive technicalities, to combine this contract with other contracts when considering contract award, and to accept any bid which it deems in the best interest of the District.

The KID hereby notifies all bidders that it encourages and will affirmatively ensure that in any contract entered into, pursuant to this invitation, certified minority and women's business enterprises will be afforded full opportunity to submit bids in response to the invitation and will not be discriminated against on the grounds of race, color, national origin, or sex in consideration for an award. Certification information for the MWBE businesses is available at <http://www.omwbe.wa.gov>.

Bidders shall certify that it or its principals are not presently debarred, suspended proposed for debarment, declared ineligible, or voluntarily excluded from covered transactions by any Federal department or agency.

DATED: March 7, 2019

Charles Freeman, District Manager

Kennewick School District  
Horse Heaven Hills Middle School Track and Field

The Kennewick School District (Owner) will receive sealed bids for the Horse Heaven Hills Middle School Track and Field from qualified contractors. Bids will be received until 2:00 P.M. (PST) on Tuesday, March 26, 2019 at the Owner's administrative offices located at 5501 W Metairie Avenue, Kennewick, WA 99336. Bids received after the stated time will not be accepted. The bids will be publicly opened by Owner staff. Official bid results shall be made public within 48 hours of bid opening. Bids will be on a lump-sum basis awarded to the lowest responsive bidder. The Owner reserves the right to reject any or all bids or to waive informalities in the bidding. No bids shall be withdrawn for a period of 30 days subsequent to the opening of the bids without the written consent of the Owner. There will be a non-mandatory pre-bid walk through for all bidding general contractors on Tuesday, March 20, 2019 at 4:00 p.m. at Horse Heaven Hills Middle School located at 3500 S Vancouver Street, Kennewick WA 99336. Subcontractors are also welcome. The Owner is proposing to construct a new paved track and field.

**ORDINANCE NO. 15-19 AN ORDINANCE** of the City of Richland amending the 2019-2024 Capital Improvement Plan and 2019 Budget to provide for additional appropriations in the City's Streets Capital Construction Fund, City Streets Fund, Capital Improvements Fund and Industrial Development Fund and declaring that a public emergency exists in the Capital Improvements Fund and Industrial Development Fund. Ordinance effective the day following its publication. Ordinance available at the City Clerk's Office, 975 George Washington Way, Richland, WA 99352 or (509) 942-7388.

**ORDINANCE NO. 16-19 AN ORDINANCE** of the City of Richland amending the 2019 Budget and 2019-2024 Capital Improvement Plan to provide for additional appropriations and declaring that a public emergency exists in the City's Equipment Replacement Fund. Ordinance effective the day following its publication. Ordinance available at the City Clerk's Office, 975 George Washington Way, Richland, WA 99352 or (509) 942-7388.

**ORDINANCE NO. 17-19 AN ORDINANCE** of the City of Richland amending Chapter 2.18 of the Richland Municipal Code related to the Parks and Recreation Commission. Ordinance available at the City Clerk's Office, 975 George Washington Way, Richland, WA 99352 or (509) 942-7388.

**Reclamation Announces Negotiations** with the East Columbia Basin Irrigation District for Amendment of Renewal Master Water Service Contract

The Bureau of Reclamation invites interested members of the public to observe a working session with the East Columbia Basin Irrigation District (District). The purpose of this session will be for Reclamation and the District to arrive at mutually agreeable terms and conditions for a proposed amendment to Renewal Master Water Service Contract No. 159E101882 that would, among other things, authorize the District to provide Columbia Basin Project irrigation water as groundwater replacement irrigation water service to additional irrigable lands located within the Odessa Subarea and within the service area of the District.

The contract amendment will reflect existing Federal Reclamation law and policy governing water service contracts. The goal of the negotiations is to arrive at a mutually agreeable contract. The negotiation session will be held:

March 21, 2019 at 10:00 a.m.  
Wingate by Wyndham, Spokane Airport  
2726 S. Flint Road  
Spokane, WA 99224

Only persons authorized to act on behalf of the contracting parties may negotiate the terms and conditions of the contract amendment which is the subject of this negotiation session. However, interested parties are welcome to attend and will have the opportunity to provide comments regarding this contracting action. The negotiators do not plan to respond at the session to comments from observers. Copies of the latest draft of proposed contract amendment will be available at the session. For additional information regarding this notice, please contact: Amy Rodman, Bureau of Reclamation, Ephrata Field Office, at (509) 754-0238, or Michael Cobelli, Regional Office, Boise, at (208) 378-5223.

Tuesday March 12: Benton Irrigation District is having a Board of Directors meeting at 3:00 PM at the Benton Irrigation District office at 47506 Highland Rd. The meeting is open to the public.

Monday March 25: The Benton Irrigation District is having a Board of Directors meeting at 8:00 AM at the Benton Irrigation District office at 47506 Highland Rd. The meeting is open to the public.

# Auto Savers

Vehicles \$6,000 or less,  
3 lines for 14 days

**Sell it fast!**  
**Call 586-6181**

**Tri-City Herald**  
tricityherald.com  
VOICE OF THE MID-COLUMBIA



To place your Legal Announcement, Call 585-7213.



---

## 276-BA Organic Storage Area permit modification 30-Day Advance Notice

The Washington State Department of Ecology is providing notification of a 45-day public comment period starting early to mid-March 2019. This comment period will address proposed modifications to the Hanford Facility Resource Conservation and Recovery Act Permit, Revision 8c (Permit) for the 276-BA Organic Storage Area. The proposed changes will be located in Part IV, Closure Unit Group 32 of the Permit. The Permittees are U.S. Department of Energy Richland Operations and CH2M Hill Plateau Remediation Company. The draft class 3 permit modification was submitted to Ecology on May 4, 2016, with the first 60 day comment period held in the summer of 2016. The 276-BA Organic Storage Area is located in the northeast portion of the B Plant Complex in the 200 East Area of the Hanford Site in southeastern Washington.

### What Changes are Being Proposed?

The proposed permit modification will add 276-BA Organic Storage Area Closure Plan and Permit Conditions to the Permit. The proposed draft language describes clean closure in the closure plan.

### Public Hearing

A public hearing is not scheduled, but if there is enough interest, we will consider holding one. To request a hearing or for more information, contact:

Daina McFadden  
Hanford@ecy.wa.gov  
509-372-7950 



Visit us on the [web](#) and follow our [news and social media](#).

[Subscribe](#) or [Unsubscribe](#)

**From:** [Wireman, Ginger \(ECY\)](#)  
**To:** [HANFORD-INFO@LISTSERV.ECOLOGY.WA.GOV](mailto:HANFORD-INFO@LISTSERV.ECOLOGY.WA.GOV)  
**Subject:** 276-BA Organic Storage Area Public Comment Period Notification  
**Date:** Monday, March 11, 2019 11:07:57 AM

---

## 276-BA Organic Storage Area Public Comment Period Notification

The Washington State Department of Ecology is providing notification of a 45-day public comment period starting March 11 through April 26, 2019. This comment period will address proposed modifications to the *Dangerous Waste Portion for the Treatment, Storage, and Disposal of Dangerous Waste* for the 276-BA Organic Storage Area. The Permittees are the U.S. Department of Energy Richland Operations (USDOE) and CH2MHill Plateau Remediation Company. The 276-BA Organic Storage Area is located on the Hanford Site in southeastern Washington.

### What Changes are Being Proposed?

The Class 3 permit modification will include the following:

- Unit Specific Permit Conditions
- Addendum H, Closure Plan which proposes clean closure activities that will be completed within 180 days of the start date. USDOE initiated a Class 3 permit modification to add the 276-BA Organic Storage Area to the Permit on May 4, 2016. The 60-day public comment period as required by Washington Administrative Code (WAC) 173-303-830(4)(c) began on April 25, 2016, and ended on August 6, 2016.

Ecology issued a Letter of Incompleteness and Notice of Deficiency for the Class 3 Permit Modification Request on August 11, 2016. We resolved the deficiencies with the permittees and the permit modification to be complete. Ecology responded to comments submitted by two members of the public during that comment period. Following the comment period held in 2016, significant changes were made to the Closure Plan as part of Ecology's completeness determination and technical review. Changes to the closure plan include the following:

- The 276-BA container was part of the B Plant Organic Mixed Waste Storage System and previously classified as a tank in the B Plant Complex Part A Form. Upon further review, USDOE determined that 276-BA ISO East should be classified as a container because it meets the RCRA definition of container in WAC-173-303-040. 276-BA ISO East will be closed under the container standards in WAC 173-303-630(10).
- In addition, the components of the United States Environmental Protection Agency 7 Step Data Quality Objectives were evaluated and identified in the Closure Plan for 276-BA Organic Storage Area.

### How to Comment

Ecology invites you to review and comment on this proposed 276-BA Organic Storage Area Permit Modification. Copies of the proposed modification are located in the [Administrative Record and Information Repositories](#). In addition, the proposed modification is online at <https://ecology.wa.gov/Waste-Toxics/Nuclear-waste/Public-comment-periods>.

Please submit comments by **April 26, 2019**. Electronic submission (preferred): <http://wt.ecology.commentinput.com/?id=YPUpu>

Mail or hand-deliver to:

Daina McFadden

3100 Port of Benton Blvd

Richland WA 99354  
Fax 509-372-7971

### Public Hearing

A public hearing is not scheduled, but if there is enough interest, we will consider holding one. To request a hearing or for more information, contact:

Daina McFadden  
[Hanford@ecy.wa.gov](mailto:Hanford@ecy.wa.gov)  
509-372-7950

For more information, contact:

Stephanie Schlieff  
[Hanford@ecy.wa.gov](mailto:Hanford@ecy.wa.gov)  
(509)372-7950

---

Ecology logo



Visit us on the [web](#) and follow our [news and social media](#).

[Subscribe](#) or [Unsubscribe](#)