



**Response to Comments
NUCON Thermal Oxidation
System Phase 3
Aug. 26 – Oct. 10, 2024**

For the **Nuclear Waste Program**

Washington State Department of Ecology

Richland, Washington

December 2024, Publication 24-05-012



Publication Information

This document is available on the Department of Ecology, [Nuclear Waste Program's Publication page](#).¹

Ecology publishes this document to meet the requirements of [Washington Administrative Code 173-303-840 \(9\)](#).

Author

Amie Green, Environmental Specialist and Rev. 9 Permit Coordinator

Cover photo credit

- Photo by Washington State Dept. of Ecology, July 26, 2020

Contact Information

Daina McFadden
Permit Communication Specialist
Nuclear Waste Program
3100 Port of Benton Blvd
Richland, WA 99354
Phone: 509-372-7950
Email: Hanford@ecy.wa.gov

Website²: [Washington State Department of Ecology](#)

ADA Accessibility

The Department of Ecology is committed to providing people with disabilities access to information and services by meeting or exceeding the requirements of the Americans with Disabilities Act (ADA), Section 504 and 508 of the Rehabilitation Act, and Washington State Policy #188.

To request an ADA accommodation, contact Ecology by phone at 509-372-7950 or email at Daina.McFadden@ecy.wa.gov. For Washington Relay Service or TTY call 711 or 877-833-6341. Visit Ecology's website for more information.

¹ <https://apps.ecology.wa.gov/publications/summarypages/2405012.html>

² www.ecology.wa.gov/contact

Department of Ecology's Regional Offices

Map of Counties Served



| | | | |
|---|---|---------------------------------------|---------------------------------------|
| Southwest Region 360-407-6300 | Northwest Region 206-594-0000 | Central Region 509-575-2490 | Eastern Region 509-329-3400 |
|---|---|---------------------------------------|---------------------------------------|

| Region | Counties Served | Mailing Address | Phone |
|---------------------|--|--|--------------|
| Southwest | Clallam, Clark, Cowlitz, Grays Harbor, Jefferson, Mason, Lewis, Pacific, Pierce, Skamania, Thurston, Wahkiakum | PO Box 47775 Olympia, WA 98504 | 360-407-6300 |
| Northwest | Island, King, Kitsap, San Juan, Skagit, Snohomish, Whatcom | PO Box 330316 Shoreline, WA 98133 | 206-594-0000 |
| Central | Benton, Chelan, Douglas, Kittitas, Klickitat, Okanogan, Yakima | 1250 W Alder St Union Gap, WA 98903 | 509-575-2490 |
| Eastern | Adams, Asotin, Columbia, Ferry, Franklin, Garfield, Grant, Lincoln, Pend Oreille, Spokane, Stevens, Walla Walla, Whitman | 4601 N Monroe Spokane, WA 99205 | 509-329-3400 |
| Headquarters | Across Washington | PO Box 46700 Olympia, WA 98504 | 360-407-6000 |

Response to Comments NUCON Thermal Oxidation System Phase 3

Aug. 26 – Oct. 10, 2024

Nuclear Waste Program
Washington State Department of Ecology
Richland, WA

December 2024 | Publication 24-05-012



DEPARTMENT OF
ECOLOGY
State of Washington

Table of Contents

Introduction 6

Reasons for Issuing the Permit..... 7

Public Involvement Actions 7

List of Commenters 8

Attachment 1: Comments and Responses

Appendix A. Copies of All Public Notices

Introduction

The Washington State Department of Ecology’s Nuclear Waste Program (Ecology) manages dangerous waste within the state by writing permits to regulate its treatment, storage, and disposal. When a new permit or a significant modification to an existing permit is proposed, Ecology holds a public comment period to allow the public to review the change and provide formal feedback. (See [Washington Administrative Code \[WAC\] 173-303-830](#) for types of permit changes.)

The Response to Comments is the last step before issuing the final permit, and its purpose is to:

- Specify which changes, if any, of a permit will become effective upon issuance of the final permit, providing reasons for those changes.
- Describe and document public involvement actions.
- List and respond to all significant comments received during the public comment period and any related public hearings.

This Response to Comments is prepared for:

| | |
|------------------------|---|
| Comment period | <i>NUCON Thermal Oxidation System Phase 3, Aug. 26 – Oct. 10, 2024</i> |
| Permit | <i>Hanford Facility Resource Conservation and Recovery Act (RCRA) Permit for the Treatment, Storage, and Disposal of Dangerous Waste, Research, Development and Demonstration NUCON Thermal Oxidation System Phase 3 Permit</i> |
| Permittees | U.S. Department of Energy, Hanford Field Office Washington River Protection Solutions |
| Original Issuance date | Dec. 2, 2024 |
| Effective date | Jan. 1, 2025 |

To see more information related to the Hanford Site and nuclear waste in Washington, please visit our webpage, [Hanford Cleanup](#)³.

³ <https://www.ecology.wa.gov/Hanford>

Reasons for Issuing the Permit

The purpose of the NUCON® Thermal Oxidation System (TOS) Research, Development, and Demonstration (RD&D) permit is to authorize the proposed onsite testing of the NUCON® TOS to accelerate the permitting of experimental and innovative treatment alternatives. The NUCON® Phase 3 RD&D project will evaluate the effectiveness and capabilities of an innovative control technology for reducing hazardous tank vapors in air emissions from Hanford waste tanks.

Public Involvement Actions

We encouraged public comment on the NUCON® TOS Phase 3 RD&D permit during a 45-day, public comment period held Aug. 26 – Oct. 10, 2024.

We notified the public by:

- Mailing a public notice announcing the comment period to 932 members of the public.
- Placing a public announcement legal classified notice in the Tri-City Herald on Aug. 25, 2024.
- Emailing a notice announcing the start of the comment period to the Hanford-Info email list, which has 1,699 recipients.
- Posting the comment period notice on the Washington Department of Ecology – Hanford’s Facebook and Twitter/X pages.

The Hanford information repositories located in Richland, Spokane, and Seattle, Washington, and Portland, Oregon, received the following documents for public review:

- Focus sheet
- Transmittal letter
- Statement of Basis for the proposed NUCON TOS Phase 3 RD&D permit
- Draft RD&D NUCON TOS Phase 3 RD&D Permit

The following public notices for this comment period are in [Appendix A](#) of this document:

- Focus sheet
- Classified notice in the Tri-City Herald
- Notices sent to the Hanford-Info email list
- Notices posted on the Washington Department of Ecology – Hanford’s Facebook and Twitter pages

List of Commenters

The table below lists the names of organizations or individuals who submitted a comment on the NUCON TOS Phase 3 RD&D permit. The comments and responses are in [Attachment 1](#).

| Commenter | Organization |
|-----------------|--------------|
| Baggett, George | Citizen |
| Pigott, Judy | Citizen |

Attachment 1: Comments and Responses

Description of comments:

Ecology accepted comments from Aug. 26 – Oct. 10, 2024. This section provides a summary of comments that we received during the public comment period and our responses, as required by RCW 34.05.325(6)(a)(iii). Comments are grouped by individual, and each comment is addressed separately.

I-1: GEORGE BAGGETT

Comment I-1-1

In response to the recent request for public comment - Publication 24-20-008, I'm interested in the process and what is expected. Reviewing the general system diagram, I assume there are organic vapors in BY-108 to be filtered and condensate will return to BY-108. Filtered product will then be transferred to the MERSORB bed. The out flow of the MERSORB bed will then be cooled and prior to being oxidized before venting to the atmosphere.

Response to I-1-1

The NUCON Thermal Oxidation System will draw out the vapors from BY-108. The airstream from the SST headspace carrying the vapors will be conditioned, filtered through 2 HEPA filters, treated by thermal oxidation, and exhausted to the atmosphere. The filtered condensate will be collected and go back into BY-108.

Comment I-1-2

I assume there is a chemical description of the process, from an assessment of the vapors and particulate matter in BY-108. My thought is that it would be helpful to have the physical chemistry shown to enable a fair assessment.

Response to I-1-2

The chemical description can be found in TOC-ENV-NOC-5394, Rev 02, "Criteria and Toxics Air Emissions Notice of Construction for the Installation and Operation of the Thermal Oxidation System at Single-Shell Tank 241-BY-108" (attachment of letter 23-ECD-000913). This can be found in the Hanford Administrative Record (Accession number AR-23873) Record Details | Administrative Records/Public Information Repository (hanford.gov).

Comment I-1-3

As proposed, I'm curious about the life of the MERSORB bed, and the disposition of what is collected. I'm also interested in the chemical makeup of what is planned to go to the Thermal Oxidation system so the products of (complete or incomplete) combustion can be assessed.

I'm guessing that some of these questions have been addressed, and are in some previous documentation, but... Any light on this would be helpful.

Response to I-1-3

Section 4.2.2 of the NUCON RD&D permit application (ORP-68783) provides a general description of the MERSORB® filter and references RPP-CALC-63389 for the design and sizing of the unit to effectively treat the anticipated vapor mercury concentration for the planned duration. The attached excerpt is taken from that calculation document. Based on these calculations and the highest mercury concentration measured in BY-108 (0.00046 mg/ft³), the anticipated bed life is greater than 16,000 years.

I-2: JUDY PIGOTT

Comment I-2-1

Hello — my goal is to provide a brief comment on the permit application. I have visited the website that purports to support this goal, and read that the links are broken. Therefore I'm typing and email in this fashion.

From what I've read and researched, this current approach to increasing the safety of workers & members of the public near the waste-holding tanks at Hanford has great promise. It should be tested thoroughly, of course. If the hazardous tank vapors in air emissions from the waste tanks can be controlled and largely (or fully) eliminated, then other plans to move the wastes can proceed without incurring further danger of damage to anyone. Please proceed.

Response to I-2-1

The NUCON Thermal Oxidation System has been tested in a phased approach with initial testing being performed at the NUCON facility in Ohio. In a second phase of testing, the NUCON system was shipped to PNNL to be tested in a controlled environment. Worker's safety is the first priority and the system will be monitored while in use during the in-field testing planned for CY2026. Vapor monitoring and detection systems are deployed throughout the Tank Farms, and along with routine usage of appropriate personnel protective equipment, provide a robust safety program protecting human health and the environment.

Appendix A. Copies of All Public Notices

Public notices for this comment period:

- Focus sheet
- Classified notice in the Tri-City Herald
- Notices sent to the Hanford-Info email list
- Notices posted on Washington Department of Ecology – Hanford’s Facebook and Twitter pages

NUCON Thermal Oxidation System Phase 3

Research, Development and Demonstration Permit Application



Figure 1. Columbia River looking at the Hanford Site

- Public comment period Aug. 26 12:00 a.m. – Oct. 10, 2024 11:59 p.m.
- This is a research, development, and demonstration (RD&D) permit
- Located in the 200 East Area of the Hanford Site

Public comment invited

The Washington State Department of Ecology (Ecology) is proposing a draft RD&D permit for the NUCON Thermal Oxidation System (TOS) located in the 200 East Area of the Hanford Site.

The permittee is:

U.S. Department of Energy
(Owner/Operator)
P.O. Box 450,
Richland, WA 99352

Background

The Hanford Site occupies 580 square miles in southeastern Washington State. The site produced plutonium for the nation's defense program from 1943 to the late 1980s. Today, waste management and environmental cleanup are the primary missions at Hanford.

Overview & Changes

The U.S. Department of Energy is proposing to construct and operate a TOS developed by NUCON International, Inc. (NUCON^{®1}). This permit would authorize the testing of the NUCON TOS.

NUCON[®] TOS will be temporarily located in the 200 East Area of the Hanford Site. This onsite testing is Phase 3 of experimental testing to demonstrate the feasibility of a process to reduce or remove toxic chemicals from Hanford tank air emissions from Single-Shell Tank BY-108.

Facility Background

The purpose of the NUCON[®] TOS RD&D permit is to authorize the proposed onsite testing of the NUCON[®] TOS to accelerate the permitting of experimental and innovative treatment alternatives.

The NUCON[®] Phase 3 RD&D project will evaluate the effectiveness and capabilities of an innovative control technology for reducing hazardous tank vapors in air emissions from Hanford waste tanks.

¹ NUCON[®] is a registered trademark of NUCON International, Inc., Columbus, Ohio.

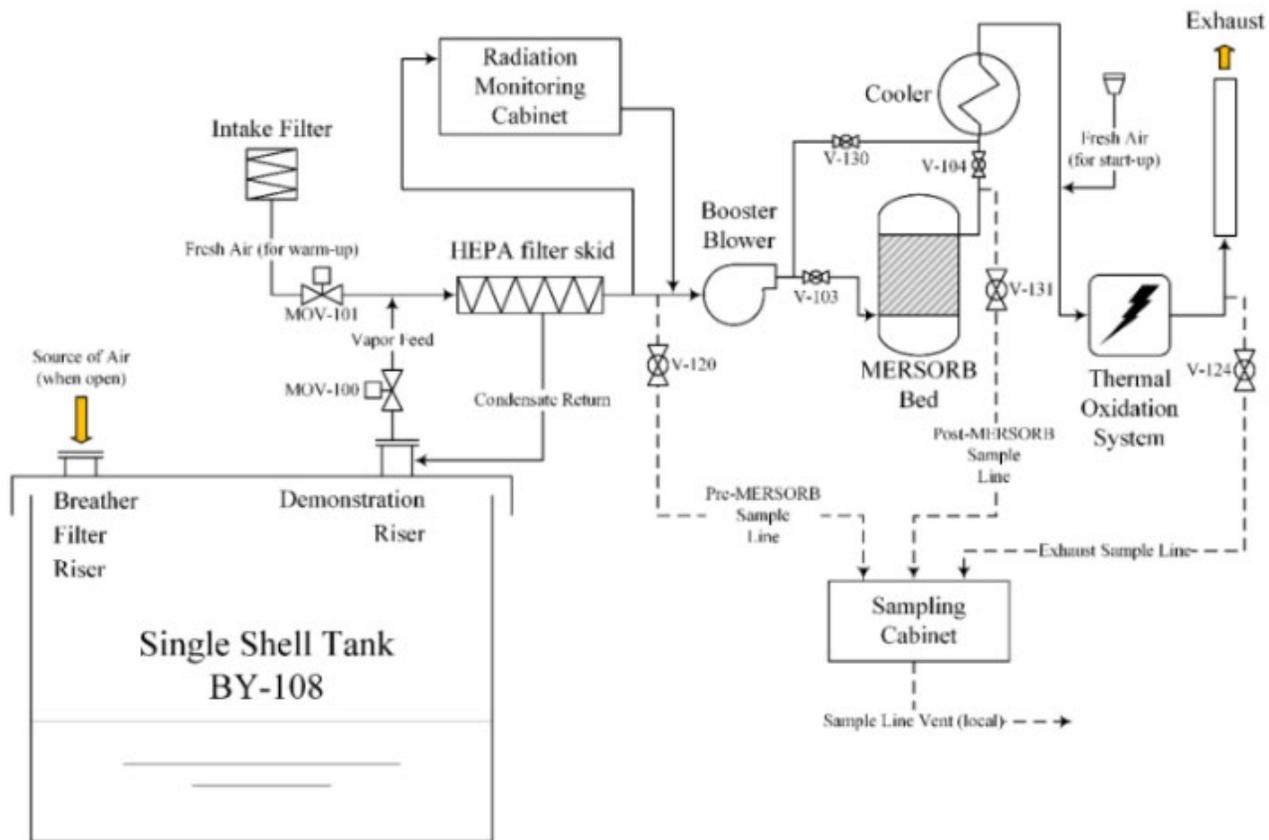

Figure 2 General System Diagram of the NUCON® TOS to be installed on Hanford Single-Shell Tank BY-108.

Reviewing the proposed changes

Ecology invites you to review and comment on this proposed draft RD&D permit modification. See the last page for comment period dates and information on how to submit comments.

Copies of the application for the proposed permit, the draft permit, fact sheet, and supporting documentation will be available during the public comment period online at Ecology’s website². The documents will also be available electronically at the Hanford Public Information Repositories listed on the next page.

Ecology will consider and respond to all significant comments received during the public comment period. We will document our responses and issue a response to comments document when we make our final permitting decision.

² [Ecology.wa.gov/Waste-Toxics/Nuclear-waste/Public-comment-periods](https://ecology.wa.gov/Waste-Toxics/Nuclear-waste/Public-comment-periods)

Hanford's Information Repositories

Ecology Nuclear Waste Program
Resource Center
3100 Port of Benton Blvd.
Richland, WA 99354
509-372-7950

Washington State University Tri-Cities
Department of Energy Reading Room
2770 Crimson Way, Room 101L
Richland WA 99354

University of Washington
Suzzallo Library
Box 352900
Seattle, WA 98195
206-543-5597

Gonzaga University
Foley Center
502 E Boone Avenue
Spokane, WA 99258
509-313-6110

Portland State University
PSU Library is temporarily closed
Millar Library
1875 SW Park Avenue
Portland, OR 97207
503-725-4542

For information on other comment periods or ways to get involved, go to ecology.wa.gov/Hanford and click "Public comment periods" on the left bar or visit Hanford.gov "public involvement opportunities".

You can also follow us on social media.



@EcologyWAHanford



@ecyHanford

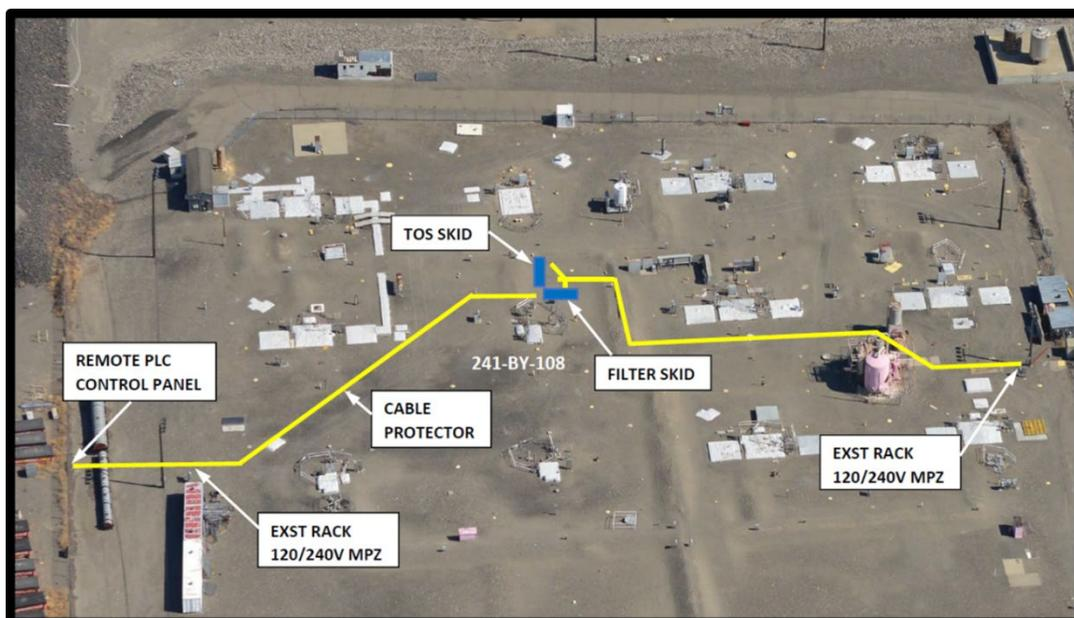

Figure 3: NUCON Phase 3 Research, Development, and Demonstration Project Site Plan.



Nuclear Waste Program
 3100 Port of Benton Blvd
 Richland WA 99354

NUCON RD&D Permit application

Aug. 26 12:00 a.m. to Oct. 10 11:59 p.m.



Electronic submission (preferred):
[NUCON RD&D permit application](#)

Mail or hand-delivery

Daina McFadden
 3100 Port of Benton Blvd
 Richland, WA 99354

A public hearing is not scheduled, but if there is enough interest, we will consider holding one. To request a hearing or for more information, contact:

Daina McFadden
 509-372-7950
 Hanford@ecy.wa.gov

HANFORD SITE
 586 square miles

NUCON TOS

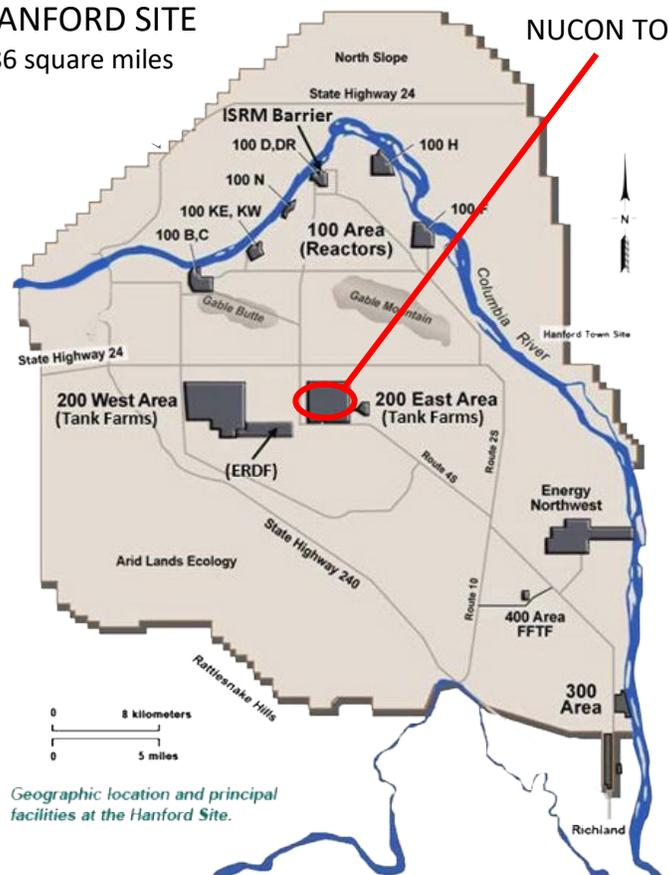

Geographic location and principal facilities at the Hanford Site.

To request an ADA accommodation, contact Ecology by phone at 509-372-7950 or email at Daina.McFadden@ecy.wa.gov, or visit ecology.wa.gov/Accessibility. For Relay Service or TTY call 711 or 877-833-6341.

Classified

FIND. BUY. SELL.

classifieds.tri-cityherald.com

SELL YOUR STUFF FAST!

509.582.1500

Legals

Call for Bids
Sunnyside Valley Irrigation District
120 S 11th Street P.O. Box 239
Sunnyside, WA 98944
509-837-6980

Sunnyside Valley Irrigation District (SVID) will receive sealed bids at the SVID Field office, 1105 Yakima Valley Hwy, PO Box 239, Sunnyside, WA 98944, until 11:00 a.m. on Monday September 9, 2024 for PVC materials to be used in 2025 SVID Projects. Bids will then be opened and publicly read aloud. Proposals received after this time will not be considered.

Contract documents may be obtained from the SVID Field Office at 1105 Yakima Valley Hwy, Sunnyside, or by contacting Mr. Gerardo Villalobos villalobosg@svid.org or by calling (509) 837-6980. Addenda will be e-mailed to bidders who have signed for or requested contract documents through this office.

The following is applicable to federal aid projects: Sunnyside Valley Irrigation District, in accordance with Title VI of the Civil Rights Acts of 1964, 88 Stat. 352, hereby notifies all bidders that it will affirmatively ensure that in any contract entered into pursuant to this advertisement, disadvantaged business enterprises will be afforded full opportunity to submit bids in response to this invitation and will not be discriminated against on the grounds of race, color, or national origin in consideration for an award.

Ron Cowin, P.E.
 Sunnyside Valley Irrigation District
 Assistant Manager – Engineering
 IPL0190445
 Aug 25, Sep 1 2024

Pacific Northwest National Laboratory, operated by Battelle, is soliciting organizations interested in operating a breakfast / lunch / catering service within an existing Federal facility.

PNNL intends to solicit this service from area restaurants, but other interested parties will be considered. The decision-making process is expected to take no more than 90 days. By replying, interested parties would get notification of the procurement action. Interested parties should respond by August 30, 2024 by contacting Valerie Hiner, PNNL Contract Specialist, at (509) 371-7151 or valorie.hiner@pnnl.gov for additional details.
 IPL0188419
 Aug 14, 18, 21, 25, 28 2024

CITY OF RICHLAND Public Hearing and Public Comment Regarding Community Needs for the Tri-Cities HOME Consortium 2025-2029 Consolidated Plan September 25, 2024

The City of Richland's Planning Commission will hold a public hearing and a written public comment period to provide an opportunity for citizens to express views and comments on community development and housing needs, benefiting low-and moderate-income persons to inform its 2025-2029 Tri-Cities Consolidated Plan. The Consolidated Plan guides the use of federal HOME Investment Partnership Program (HOME) and Community Development Block Grant (CDBG) funds received by the three jurisdictions. The City of Richland serves as the lead entity for the Tri-Cities HOME Consortium and administers HOME funds on behalf of all three jurisdictions. The Cities of Richland, Kennewick, and Pasco each receive separate allocations of CDBG funds. The City of Richland anticipates receiving approximately \$295,000 in CDBG funds and \$653,000 in HOME funds per year from the U.S. Department of Housing and Urban Development (HUD).

Persons who wish to provide comment on community needs may submit written comments to tlehman@ci.richland.wa.us. Comments must be submitted by **September 25, 2024, at 5:00 PM.**

Persons who wish to provide verbal comments may do so at the public hearing. The public hearing will be held on **September 25, 2024, 6:00 PM.**, at 625 Swift Blvd, Richland, WA. The Council Chambers is fully accessible. If you need special accommodations, please contact Toni Lehman, 509-942-7580 or tlehman@ci.richland.wa.us at least 72 hours before the hearing date.
 IPL0188928
 Aug 18, 25 2024

Port of Benton - Railroad Materials - Request for Quote

Solicitation Title – Port of Benton, 2024 CrossTies

The Port of Benton requests proposals from your company for the Port of Benton – 2024 CrossTies - Solicitation Number POB-RR-M-24-2.

Port of Benton intends to replace crossTies in various locations on its main track in the near future. Work under this contract shall consist of the following general elements:

Furnish approx. 3,280 – 4,000 each 7x9x8.5' Grade 5 Hardwood Ties to nearest truckload via truck or railcar via rail POB Rail Shops – 2579 Stevens Drive, Richland, WA 99354 (as further detailed in the RFQ)

Proposals will be accepted until 11:00 AM on Wednesday September 4th, 2024, via email and as indicated in the RFQ.

Solicitation documents will be available by e-mail directly from the Port of Benton (only), 3250 Port of Benton Blvd, Richland, WA 99354 (scollins@portofbenton.com); phone (509) 375-3060. RFQ document will not be available by other means.

Questions shall be submitted in writing - via email through August 30, 2024.

Published Tri-City Herald
 Sunday August 18th and
 Sunday August 25th, 2024.
 IPL0189258
 Aug 18, 25 2024

BENTON COUNTY WATER CONSERVANCY BOARD

The BCWCW will be holding a regular meeting to review water right change/transfer application(s) being proposed by Port of Kennewick and other pending applications. Other meeting agenda items include: 1) Public Hearing upon request for any Board actions under review (for more information contact 509-783-1623); 2) Update on HHH-DNR and US Row Crops C/T decisions, and Mercer Ranches submitted applications tracking numbers; 3) General budget items; and 4) other items including an executive session to cover legal issues, if needed. This meeting is on August 29, 2024, at 4:00 p.m., at the office of Pacific NW Project, 3030 W. Clearwater, Ste. 205-A, Kennewick, WA (509-783-1623). Call-in contact numbers/vid-links will be provided upon request at 509-783-1623.
 IPL0190268
 Aug 25 2024

CITY OF PASCO SUMMARY OF ORDINANCE NO. 4724

AN ORDINANCE OF THE CITY COUNCIL OF THE CITY OF PASCO, WASHINGTON DECLARING PUBLIC USE AND NECESSITY REGARDING THE CITY OF PASCO BROADMOOR AND SANDIFUR PARKWAY INTERSECTION IMPROVEMENT PROJECT, AND AUTHORIZING CONDEMNATION

Ordinance Summary:
 *Franklin County Tax Parcel No. 115430017
 *This Ordinance shall take full force and effect five (5) days after approval, passage and publication as required by law.

The full text of the ordinance is available free of charge and will be mailed (electronically or via postal service) to any person who requests it from the City Clerk of the City of Pasco (509) 544-3096, P.O. Box 293, Pasco, Washington 99301-0293.

City Clerk's Office
 IFL0190275
 Aug 25 2024

CITY OF PASCO NOTICE OF PUBLIC HEARING

PLEASE TAKE NOTICE that the Pasco City Council will hold a Public Hearing on September 9, 2024 at 7:00 p.m. in the City Council Chambers, at 525 North 3rd Avenue, to consider the approval of the 2023 Comprehensive Plan Amendment Docket. The Pasco City Council takes review action consistent with RCW 36.70A.130.

Proposed Amendments:
File Number: CPA 2023-001: Future Land Use Map Amendment: Low Density Residential to Medium Density Residential
Addresses / Parcels
 3015 Road 100 & 9904 W Argent Road / 118292036 & 118292027
General Location Southeast of the intersection of Road 100 & W Argent Road

File Number: CPA 2022-003: Future Land Use Map Amendment: Industrial to Mixed Residential and Commercial
Address / Parcel(s) 112470014, 112430012, 112430021, 112462078, 112462096
General Location South of E A Street, between S Cedar Avenue and Manzanita Lane

Written comments may be submitted between Sunday, August 25, 2024 and Thursday, September 5, 2024 by 5:00 PM to cityclerk@pasco.wa.gov or delivered to City Clerk's Office in City Hall located at 525 N. Third Avenue, Pasco, WA 99301.

Public comments may be provided during the scheduled hearing or if you prefer to participate in the hearing virtually, please register at least 3 hours prior to the meeting (typically by 4:00 PM) at: www.pasco-wa.gov/publiccomment. After registering, you will receive a confirmation email containing instructions on how to join the webinar.

Pasco School District- Irrigation Re-Route INVITATION TO BID

PASCO SCHOOL DISTRICT No. 1
 1215 W. Lewis Street Pasco, WA 99301

PBS Engineering and Environmental
 400 Bradley Boulevard; Suite 106
 Richland, WA 99352
 Phone 509-942-1600

You are invited to bid on a General Contract for construction in the City of Pasco for Pasco School District-

Construction of the: Pasco School District – Irrigation Re-Route

Preliminary Estimate:
 Base Bid: \$398,000

Proposals will be accepted by the District until 2:00 PM., prevailing time, on September 18th, 2024 at the Pasco School District Booth Building at 1215 W. Lewis Street, Pasco, WA. Bid proposals will be opened publicly and read aloud at 2:00 PM. Interested parties are invited to attend. ELECTRONIC BIDS WILL NOT BE ACCEPTED

A Pre-Bid Conference, optional for all General Contractor prospective bidders, will be held September 10th, at 2:00 PM at the project site. We will meet at the entrance to the site located on the north side of Burns Road at the intersection of Road 108 near the existing cell phone tower.

Plans and Specifications are available, beginning August 27th, 2024 through the Engineer.

E-mailed PDF drawings and specifications are available at no cost. Contact Amy Nickolaus with PBS Engineering and Environmental by e-mail at amy.nickolaus@pbsusa.com to request documents.

Contact: Amy Nickolaus at PBS Engineering and Environmental (509)-942-1600, amy.nickolaus@pbsusa.com to procure plans and specifications.

Bid security amounting to five percent (5%) of the total Base Bid must accompany each Bidder's proposal in accordance with Instructions to Bidders.

No bidder may withdraw his proposal after the date and time set for opening thereof or before Award of Contract. Unless said award is delayed beyond 30 days. Substantial Completion shall be achieved in compliance with the project specifications.

The project requires compliance with prevailing wage under RCW 39.12.

The District reserves the right to accept or reject any or all proposals and in particular, to reject a proposal not accompanied by the required bid security or data required. The process shall comply with RCW 28A.335.190 and RCW 43.19.1906.
 IFL0190356
 Aug 25, Sep 1 2024

CITY OF BENTON CITY NOTICE OF CITY COUNCIL WORKSHOP MEETING

NOTICE IS HEREBY GIVEN that the City of Benton City Council will conduct a Workshop on Tuesday, September 3, 2024 at 6:00 p.m. The meeting will be held at City Hall, 1009 Dale Ave., Ste. A, Benton City, WA. Virtual participation will be offered.

Staff Contact: Carla Meyer, City Clerk/
 Treasurer, 509-588-3322. cmeyer@ci.benton.city.wa.us

NOTICE DATE: WEDNESDAY,
 AUGUST 21, 2024
 IFL0190488
 Aug 25 2024

NOTICE TO SUBCONTRACTORS AND SUPPLIERS

Washington State University, acting by and through the Vice President for Finance and Administration, hereby advises all interested parties that Work Order 1T01162-BCI-0034, for the Tri-Cities Floyd Building East Stairs and Handrail project, Washington State University, Pullman, WA, with Burton Construction, Inc., 3915 E. Nebraska Avenue, Spokane, WA 99217 has achieved Final Acceptance as of August 20, 2024.

The legal lien period becomes effective for the filing of all liens and claims against the retained percentage of payment to the Contractor on the above date.

Any liens filed after October 4, 2024, will not be recognized.
 Maja S. Huff
 509 335-9082
contracts@wsu.edu
 Facilities Services
 Washington State University
 IFL0190502
 Aug 25 2024

ORDINANCE NO. 2024-25,

AN ORDINANCE of the City of Richland, Benton County Washington, Amending Richland Municipal Code Section 3.24.560 and eliminating the 1-Year Grace Period for Downtown Business Improvement District Assessments.

Ordinance is available at the City Clerk's Office, 625 Swift Boulevard MS-07, Richland, WA 99352 or 509-942-7389.
 IFL0190587
 Aug 25 2024

ORDINANCE NO. 2024-27,

AN ORDINANCE of the City of Richland, Benton County Washington, Amending Chapter 8.10 of the Richland Municipal Code related to Public Camping.

Ordinance is available at the City Clerk's Office, 625 Swift Boulevard MS-07, Richland, WA 99352 or 509-942-7389.
 IFL0190591
 Aug 25 2024

KENNEWICK PLANNING COMMISSION

NOTICE OF PUBLIC HEARING
September 9, 2024
at 6:30 p.m.

The Kennewick Planning Commission will hold a Public Hearing on Monday, September 9, 2024, at 6:30 p.m. or as soon as possible thereafter, to receive public comment/testimony on the below Comprehensive Plan Amendment. Staff will be presenting analysis and the Planning Commission will make a recommendation to City Council on the item. The public hearing will be conducted in a hybrid setting which will allow interested parties to participate in person or virtually. To participate virtually in the hearing, use the link found at <https://www.go2kennewick.com/598/Planning-Commission>.

Project# CPA-2024-0001 – To change the land use designation of 1.79 acres from Low Density Residential to Industrial. The proposal is generally located at 803 S Steptoe Street and involves two separate parcels.

Questions or written comments may be addressed to Steve Donovan and submitted to Steve.Donovan@ci.kennewick.wa.us or mailed to PO Box 6108, Kennewick, WA 99336.

The City of Kennewick welcomes full participation in public meeting by all citizens. No qualified individual with a disability shall be excluded or denied the benefit of participating in such meetings. If you wish to use auxiliary aids or require assistance to comment at this public hearing, please contact Steve Donovan at (509) 585-4361 or through the Washington Relay Service Center TTY at 711 at least ten days prior to the date of the meeting to make arrangements for special needs.
 IFL0190666
 Aug 25 2024

CITY OF WEST RICHLAND SUMMARY OF ORDINANCE 18-24

In accordance with RCW 35A.12.160, the following is a summary of City of West Richland Ord. No. 18-24 adopted on August 20, 2024.

TITLE OF ORDINANCE: AN ORDINANCE OF THE CITY COUNCIL OF THE CITY OF WEST RICHLAND, WASHINGTON, REVISING THE CORPORATE BOUNDARY OF THE CITY OF WEST RICHLAND TO INCLUDE A PORTION OF RUPPERT ROAD. THE ORDINANCE ALSO DECLARES THAT THE PROVISIONS OF THE ORDINANCE ARE SEVERABLE FROM ONE ANOTHER AND SETS FORTH THE EFFECTIVE DATE OF THE ORDINANCE AND PROVIDES FOR PUBLICATION BY SUMMARY.

The full text of this ordinance will be mailed free of charge to any person who requests the same from Stephanie Haug, City Clerk, 3100 Belmont Blvd., West Richland, Washington, 99353, (509) 967-3431.
 IFL0190821
 Aug 25 2024

STORAGE UNIT RUNNING OUT OF SPACE?

Let Classifieds Help

Tri-City Herald
 TRI-CITYHERALD.COM

KENNEWICK PLANNING COMMISSION

NOTICE OF PUBLIC HEARING RESCHEDULED
 September 9, 2024 6:30 p.m.

The Kennewick Planning Commission will hold a Public Hearing on Monday, September 9, 2024, at City Hall Council Chambers, 210 West 6th Avenue, at 6:30 p.m. or as soon as possible thereafter, to receive public comment on a proposed Comprehensive Plan Amendment. Staff will be presenting their analysis and the Planning Commission will make a recommendation to the City Council on the item. The public hearing will be conducted in a hybrid setting which will allow interested parties to participate in person or virtually. To participate virtually in the hearing, use the link found at <https://www.go2kennewick.com/598/Planning-Commission>.

Project# CPA-2024-0002 – Comprehensive Plan Amendment to change the land use designation of 0.5348 acres from Low Density Residential (LDR) to Medium Density Residential (MDR). The proposal is located at 2219 W 13th Avenue.

Submit written comments to Matt Halitsky at matt.halitsky@ci.kennewick.wa.us or mail to PO Box 6108, Kennewick, WA 99336. For questions about this project, please call Matt Halitsky (509) 585-4416

The City of Kennewick welcomes full participation in public meetings by all citizens. No qualified individual with a disability shall be excluded or denied the benefit of participating in such meetings. If you wish to use auxiliary aids or require assistance to comment at this public hearing, please contact Matt Halitsky at (509) 585-4416 or the Washington Relay Service Center TTY at #711 at least ten days prior to the date of the meeting to make arrangements for special needs.
 IFL0190670
 Aug 25 2024

KENNEWICK PLANNING COMMISSION

NOTICE OF PUBLIC HEARING
September 9, 2024
at 6:30 p.m.

The Kennewick Planning Commission will hold a Public Hearing on Monday, September 9, 2024, at 6:30 p.m. or as soon as possible thereafter, to receive public comment/testimony on the below Comprehensive Plan Amendment. Staff will be presenting analysis and the Planning Commission will make a recommendation to City Council on the item. The public hearing will be conducted in a hybrid setting which will allow interested parties to participate in person or virtually. To participate virtually in the hearing, use the link found at <https://www.go2kennewick.com/598/Planning-Commission>.

Project# CPA-2024-0003 – To change the land use designation of .55 acres from Commercial to Low Density Residential. The proposal is located at 1200 N Irving Place.

Questions or written comments may be addressed to Steve Donovan and submitted to Steve.Donovan@ci.kennewick.wa.us or mailed to PO Box 6108, Kennewick, WA 99336.

The City of Kennewick welcomes full participation in public meeting by all citizens. No qualified individual with a disability shall be excluded or denied the benefit of participating in such meetings. If you wish to use auxiliary aids or require assistance to comment at this public hearing, please contact Steve Donovan at (509) 585-4361 or through the Washington Relay Service Center TTY at 711 at least ten days prior to the date of the meeting to make arrangements for special needs.
 IFL0190705
 Aug 25 2024

KENNEWICK PLANNING COMMISSION

NOTICE OF PUBLIC HEARING RESCHEDULED
 September 9, 2024 6:30 p.m.

The Kennewick Planning Commission will hold a Public Hearing on Monday, September 9, 2024, at City Hall Council Chambers, 210 West 6th Avenue, at 6:30 p.m. or as soon as possible thereafter, to receive public comment on a proposed Comprehensive Plan Amendment. Staff will be presenting their analysis and the Planning Commission will make a recommendation to the City Council on the item. The public hearing will be conducted in a hybrid setting which will allow interested parties to participate in person or virtually. To participate virtually in the hearing, use the link found at <https://www.go2kennewick.com/598/Planning-Commission>.

Project# CPA-2024-0004 – Comprehensive Plan Text Amendment to add the expansion of the Convention Center to the Capital Facilities Plan list of projects.

Submit written comments to Matt Halitsky at matt.halitsky@ci.kennewick.wa.us or mail to PO Box 6108, Kennewick, WA 99336. For questions about this project, please call Matt Halitsky (509) 585-4416

The City of Kennewick welcomes full participation in public meetings by all citizens. No qualified individual with a disability shall be excluded or denied the benefit of participating in such meetings. If you wish to use auxiliary aids or require assistance to comment at this public hearing, please contact Matt Halitsky at (509) 585-4416 or the Washington Relay Service Center TTY at #711 at least ten days prior to the date of the meeting to make arrangements for special needs.
 IFL0190712
 Aug 25 2024

CITY OF WEST RICHLAND SUMMARY OF ORDINANCE 19-24

In accordance with RCW 35A.12.160, the following is a summary of City of West Richland Ord. No. 19-24 adopted on August 20, 2024.

TITLE OF ORDINANCE: AN ORDINANCE OF THE CITY COUNCIL OF THE CITY OF WEST RICHLAND, WASHINGTON, AMENDING THE BUDGET FOR THE CITY FOR THE BIENNium ENDING DECEMBER 31, 2024.
 The full text of this ordinance will be mailed free of charge to any person who requests the same from Stephanie Haug, City Clerk, 3100 Belmont Blvd., West Richland, Washington, 99353, (509) 967-3431.
 IFL0190823
 Aug 25 2024

Announcements

Clubs & Organizations

BICKLETON COMMUNITY DAY, SAT., AUG. 31, 9-3

Meet and Greet/Classic Vehicles, Music, Pie Sale, Flea Market, Vendors, Carousel Museum, Food

Automotive

Autos for Sale

ABANDONED VEHICLE SALE
 THURSDAY 08/29/2024 @ 11AM
 4023 W CLEARWATER AVE 99336
 CLEARWATER COLLISION & TOWING LLC
1986 FORD F-150

Employment

Employment

Garden Hot Pot
Experienced Chinese food chefs wanted

TEL:(509)378-8288
jessicaren88@yahoo.com
 140 Gage Blvd.#204,Richland WA 99352

Service Directory

Home & Business Improvement

Sprayed out Painting & Const.
 Summer specials ALL services 10% off exterior/interior paint/handyman
509-591-1237

Junk/Trash/Debris Removal

Junk, Trash & Debris Removal. BIG or small we HAUL it ALL! Sr. Discount & Free Estimates
 Call 509-851-0318 OR 509-205-5598

Lawn/Garden/Landscaping/Trees

CIRCLE LAWN & TREE CARE
 Landscaping, light pruning, hauling "We Aim to Please"
 Family owned since 1989
 Free est & Sr discounts
 509-851-0318 / 509-205-5598

Sprinkler Repair
 Valve/Filter/Timer/Sprinkler* troubleshooting 509-851-4742

Misc. Service

STORAGE STATION
 Your Storage Destination

(509) 827-1927
 Climate-Controlled Unit Alarms

WOULD SOME EXTRA CASH COME IN HANDY?

Let Classifieds Help

Tri-City Herald
 TRI-CITYHERALD.COM

Do-it-yourself classified ads

Save time and money. Go to www.tricityherald.com, click on Classifieds and follow the user-friendly steps to place your ad.

- Do-It-Yourself Convenience
- Easy to Use
- Upload Photos and Graphics
- Print and Online Options
- Basic/Deluxe/Premium Packages

Place your ad any time anywhere!

Tri-City Herald
 tricityherald.com
 VOICE OF THE MID-COLUMBIA

From: [Washington Department of Ecology](#)
To: [McFadden, Daina \(ECY\)](#)
Subject: 30-Day Advance Notice for the NUCON RD&D Permit Application public comment period
Date: Friday, July 26, 2024 9:31:19 AM



30-Day Advance Notice for the NUCON Thermal Oxidation System Phase 3 Research, Development, and Demonstration Permit Application Public Comment Period

Starting soon

Ecology will be holding a 45-day public comment period addressing a proposed NUCON®

Thermal Oxidation System (TOS) Phase 3 Research, Development, and Demonstration (RD&D) project starting in late August to early October 2024. The permittee is the U.S. Department of Energy. The NUCON® TOS will be located in the 200 East Area on the Hanford Site in southeastern Washington.

What is being proposed?

The purpose of the permit is to authorize the proposed onsite testing of the NUCON® TOS to accelerate the permitting of experimental and innovative treatment alternatives.

The NUCON® Phase 3 RD&D project will evaluate the effectiveness and capabilities of an innovative control technology for reducing hazardous tank vapors in air emissions from Hanford waste tanks.

Public hearing

A public hearing is not scheduled, but if there is enough interest, we will consider holding one. To request a hearing or for more information, contact:

Daina McFadden

Permit Communication Specialist

✉ Hanford@ecy.wa.gov

☎ 509-372-7950

From: [Washington Department of Ecology](#)
To: [McFadden, Daina \(ECY\)](#)
Subject: Public comment period start today for the NUCON Thermal Oxidation System Phase 3 RD&D draft permit
Date: Monday, August 26, 2024 10:31:27 AM



Public comment period

**NUCON Thermal Oxidation System Phase 3 draft
Research, Development and Demonstration Permit**

Aug. 26 12:00 a.m. through Oct. 10, 2024 11:59 p.m.

We are holding a 45-day public comment period addressing the proposed NUCON® Thermal Oxidation System (TOS) Phase 3 draft Research, Development, and Demonstration (RD&D) permit. The permittee is the U.S. Department of Energy. The NUCON® TOS will be located in the 200 East Area on the Hanford Site in southeastern Washington.

Proposed project

The purpose of the permit is to authorize the proposed onsite testing of the NUCON® TOS to accelerate the permitting of experimental and innovative treatment alternatives.

The NUCON® Phase 3 RD&D project will evaluate the effectiveness and capabilities of an innovative control technology for reducing hazardous tank vapors in air emissions from Hanford waste tanks.

How to comment

The proposed permit is available for review online at the Nuclear Waste Program's [public comment page](#).

Electronic copies of the proposed permit are also located at the [Administrative Record](#) and [Information Repositories](#).

Please submit comments by **Oct. 10, 2024**. [Electronically](#) (preferred) or deliver to:

Daina McFadden
3100 Port of Benton Blvd
Richland WA 99354

[Comment](#)

[Review Permit](#)

Public meeting

A public hearing is not scheduled, but if there is enough interest, we will consider holding one. To request a hearing or for more information, contact:

Daina McFadden

Permit Communication Specialist

✉ Hanford@ecy.wa.gov

☎ 509-372-7950

 **Washington Department of Ecology - Hanford**
2 hours ago · 🌐

The public comment period for the NUCON Thermal Oxidation System Phase 3 RD&D permit starts today!
This comment period will run from Aug. 26 through Oct. 10.
Check it out at <https://ecology.wa.gov/NWP-comment-periods>



HEY
Public comment period
Now open

0:05 / 0:10

Boost this post to reach up to 30 more people if you spend \$91. **Boost post**

 Daina Williams McFadden

 Like  Comment  Share

 **Ecology - Hanford** @ecyHanford · 2h

The public comment period for the NUCON Thermal Oxidation System Phase 3 RD&D permit starts today! This comment period will run from Aug. 26 through Oct. 10. Check it out at ecology.wa.gov/waste-toxics/n.....



HEY
Public comment period
Now open

0:01

    20  

NUCON Thermal Oxidation System Phase 3 draft Research, Development and Demonstration Permit

Aug. 26, 12:00 am to Oct. 10, 2024, 11:59 pm

We are holding a 45-day public comment period addressing the proposed NUCON® Thermal Oxidation System (TOS) Phase 3 draft Research, Development, and Demonstration (RD&D) permit. The permittee is the U.S. Department of Energy. The NUCON® TOS will be located in the 200 East Area on the Hanford Site in southeastern Washington.

Proposed project

The purpose of the permit is to authorize the proposed onsite testing of the NUCON® TOS to accelerate the permitting of experimental and innovative treatment alternatives.

The NUCON® Phase 3 RD&D project will evaluate the effectiveness and capabilities of an innovative control technology for reducing hazardous tank vapors in air emissions from Hanford waste tanks.

How to comment

The draft permit is available for review below.

Electronic copies of the draft permit are also located at the [Administrative Record](#) and the Information Repositories listed below.

Please submit comments by **Oct. 10, 2024**. [Electronically](#) (preferred) or deliver to:

Daina McFadden
3100 Port of Benton Blvd
Richland WA 99354

Public meeting

A public hearing is not scheduled, but if there is enough interest, we will consider holding one. To request a hearing or for more information, contact:

Daina McFadden
Hanford@ecy.wa.gov
509-372-7950

Documents

[Transmittal Letter](#)

[Focus Sheet](#)

[Fact Sheet](#)

[Change Control log](#)

[Conditions](#)

[Draft Permit](#)

[Test Plan PNNL Support to Thermal Oxidation System – Phase 3 Project \(TP-TOSP3-001\)](#)

[NUCON TOS Phase 3 Engineering Drawings](#)

Supporting Documents

[Contract 53005, Release 66 - Transmittal of Final 53005-66-Rpt-002 - Rev 0](#)